

SCAG[®]

POWER EQUIPMENT

OPERATOR'S MANUAL

SW Walk-Behind

Model: **SW32-481FS**
 SW36A-481FS
 SW48V-481FS
 SW52V-541FS



Congratulations on owning a Scag mower! This manual contains the operating instructions and safety information for your Scag mower. Reading this manual can provide you with assistance in maintenance and adjustment procedures to keep your mower performing to maximum efficiency. The specific models that this book covers are listed on the inside cover. Before operating your machine, please read all the information enclosed.



WARNING

FAILURE TO FOLLOW SAFE OPERATING PRACTICES MAY RESULT IN SERIOUS INJURY OR DEATH.

- Read this manual completely as well as other manuals that came with your mower.
- ALWAYS FOLLOW OSHA APPROVED OPERATION.
- DO NOT operate on steep slopes.
- Always travel across slopes.
- DO NOT mow on wet grass. Wet grass reduces traction and steering control.
- Keep all shields in place, especially the grass discharge chute.
- Before performing any maintenance or service, stop the machine and remove the spark plug wire and ignition key.
- If a mechanism becomes clogged, stop the engine before cleaning.
- Keep hands, feet and clothing away from power-driven parts.
- Keep others off the mower (only one person at a time)

REMEMBER - YOUR MOWER IS ONLY AS SAFE AS THE OPERATOR!

HAZARD CONTROL AND ACCIDENT PREVENTION ARE DEPENDENT UPON THE AWARENESS, CONCERN, PRUDENCE, AND PROPER TRAINING OF THE PERSONNEL INVOLVED IN THE OPERATION, TRANSPORT, MAINTENANCE, AND STORAGE OF THE EQUIPMENT.

This manual covers the operating instructions and illustrated parts list for:

SW32-481FS	with a serial number of	F9500001 to F9599999
SW36A-481FS	with a serial number of	F9700001 to F9799999
SW48V-481FS	with a serial number of	F9800001 to F9899999
SW52V-541FS	with a serial number of	F9900001 to F9999999

Always use the entire serial number listed on the serial number tag when referring to this product.

Table of Contents

SECTION 1 - GENERAL INFORMATION.....	1
1.1 INTRODUCTION.....	1
1.2 DIRECTION REFERENCE	1
1.3 SERVICING THE ENGINE AND DRIVE TRAIN COMPONENTS.....	1
1.4 SYMBOLS	2
SECTION 2 - SAFETY INFORMATION	3
2.1 INTRODUCTION.....	3
2.2 SIGNAL WORDS	3
2.3 BEFORE OPERATION CONSIDERATIONS.....	3
2.4 OPERATION CONSIDERATIONS.....	4
2.5 MAINTENANCE CONSIDERATIONS & STORAGE	5
2.6 USING A SPARK ARRESTOR.....	6
2.7 SPARK IGNITION SYSTEM	6
2.8 SAFETY AND INSTRUCTIONAL DECALS	7
SECTION 3 - SPECIFICATIONS	8
3.1 ENGINE	8
3.2 ELECTRICAL	8
3.3 ENGINE DECK	8
3.4 CUTTER DECK	9
3.5 WEIGHTS AND DIMENSIONS.....	9
3.6 PRODUCTIVITY	9
SECTION 4 - OPERATING INSTRUCTIONS	10
4.1 CONTROLS AND INSTRUMENT IDENTIFICATION	10
4.2 SAFETY INTERLOCK SYSTEM	11
4.3 INITIAL RUN-IN PROCEDURES.....	11
4.4 STARTING THE ENGINE	11
4.5 GROUND TRAVEL AND STEERING	11
4.6 ENGAGING THE DECK DRIVE (CUTTER BLADES).....	12
4.7 HILLSIDE OPERATION.....	13
4.8 PARKING THE MOWER.....	13
4.9 AFTER OPERATION	13
4.10 REMOVING CLOGGED MATERIAL	14
4.11 MOVING MOWER WITH ENGINE STOPPED	14
4.12 RECOMMENDATIONS FOR MOWING	14
SECTION 5 - TROUBLESHOOTING CUTTING CONDITIONS	15

SECTION 6 - ADJUSTMENTS	18
6.1 DRIVE CONTROL ADJUSTMENTS	18
6.2 THROTTLE CONTROL AND CHOKE ADJUSTMENTS	18
6.3 CUTTER DECK BELT ADJUSTMENTS	18
6.4 BELT ALIGNMENT	19
6.5 ADJUSTING CUTTING HEIGHT	19
6.6 ELECTRIC CLUTCH ADJUSTMENT	22
SECTION 7 - MAINTENANCE	23
7.1 MAINTENANCE CHART - RECOMMENDED SERVICE INTERVALS	23
7.2 LUBRICATION	24
7.3 ENGINE OIL	26
7.4 ENGINE FUEL SYSTEM	26
7.5 ENGINE AIR CLEANER	27
7.6 CUTTER BLADES	27
7.7 TIRES	28
SECTION 8 - ILLUSTRATED PARTS LIST	29
8.1 SCAG APPROVED ATTACHMENTS AND ACCESSORIES	29
32" & 36A CUTTER DECKS	30
48V & 52V CUTTER DECKS	32
NOTES	34
CASTER ASSEMBLY	35
ENGINE DECK	36
HANDLE ASSEMBLY	38
SW FUEL SYSTEM	40
INSTRUMENT PANEL	42
PEERLESS TRANSMISSION 700-070	43
WIRE HARNESSSES	44
NOTES	45
REPLACEMENT DECALS AND INFORMATION PLATES	46
LIMITED WARRANTY - COMMERCIAL EQUIPMENT	Following Section 8

GENERAL INFORMATION

1.1 INTRODUCTION

Your mower was built to the highest standards in the industry. However, the prolonged life and maximum efficiency of your mower depends on you following the operating, maintenance and adjustment instructions in this manual.

If additional information or service is needed, contact your Scag Power Equipment Dealer.

We encourage you to contact your dealer for repairs. All Scag dealers are informed of the latest methods to service this equipment and provide prompt and efficient service in the field or at their service shop. They carry a full line of Scag service parts.

- IMPORTANT -

The replacement of any part on this product by other than the manufacturer's authorized replacement part may adversely affect the performance, durability or safety of this product.

Use of other than original Scag replacement parts will void the warranty.

When ordering parts, always give the model and serial number of your mower. The serial number plate is located on the frame of the machine between the engine and transmission where shown in Figure 1-1.

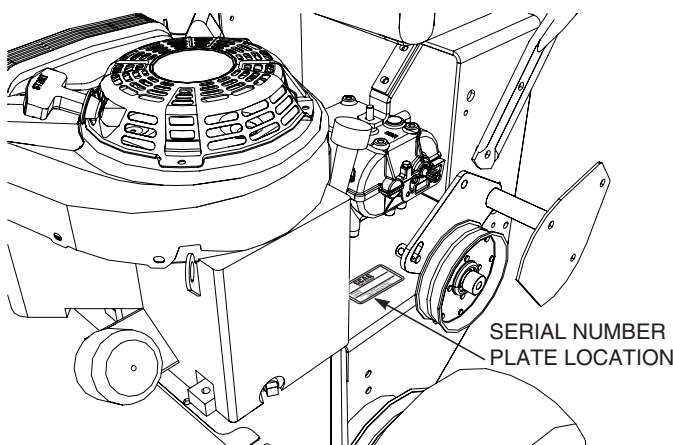

Figure 1-1. Mower Serial Number Plate Location

USE ONLY SCAG APPROVED ATTACHMENTS AND ACCESSORIES.

Attachments and accessories manufactured by companies other than Scag Power Equipment are not approved for use on this machine. See Section 8-1.

WARNING

For pictorial clarity, some illustrations and figures in this manual may show shields, guards or plates open or removed. Under no circumstances should your mower be operated without these devices in place.

All information is based upon product information available at the time of approval for printing. Scag Power Equipment reserves the right to make changes at any time without notice and without incurring any obligation.

















1.2 DIRECTION REFERENCE

The “Right” and “Left”, “Front” and “Rear” of the machine are referenced from the operator’s right and left when seated in the normal operating position and facing the forward travel direction.

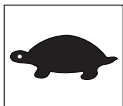
1.3 SERVICING THE ENGINE AND DRIVE TRAIN COMPONENTS

The detail servicing and repair of the engine and transmission are not covered in this manual; only routine maintenance and general service instructions are provided. For service of these components during the limited warranty period, it is important to contact your Scag dealer or find a local authorized servicing agent of the component manufacturer. Any unauthorized work done on these components during the warranty period may void your warranty.

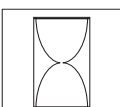
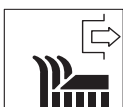
1.4 SYMBOLS

SYMBOL	DESCRIPTION	SYMBOL	DESCRIPTION
	Choke		Transmission
	Parking Brake	 <small>48071B</small>	Spinning Blade
	On/Start		Spring Tension on Idler
	Off/Stop		Oil
	Falling Hazard		Thrown Object Hazard
	Fast		Slow
	Continuously Variable - Linear		Cutting Element - Basic Symbol
 <small>481039S</small>	Pinch Point		Cutting Element - Engage
	Hour meter/Elapsed Operating Hours		Cutting Element - Disengage
	Thrown Object Hazard Keep Bystanders Away		Read Operator's Manual

SAFETY INFORMATION

2.1 INTRODUCTION

Your mower is only as safe as the operator. Carelessness or operator error may result in serious bodily injury or death. Hazard control and accident prevention are dependent upon the awareness, concern, prudence, and proper training of the personnel involved in the operation, transport, maintenance and storage of the equipment. Make sure every operator is properly trained and thoroughly familiar with all of the controls before operating the mower. The owner/user can prevent and is responsible for accidents or injuries occurring to themselves, other people or property.

READ THIS OPERATOR'S MANUAL BEFORE ATTEMPTING TO START YOUR MOWER.

A replacement manual is available from your authorized Scag Service Dealer or by contacting Scag Power Equipment, Service Department at P.O. Box 152, Mayville, WI 53050 or contact us via the Internet at www.scag.com. The manual for this machine can be downloaded by using the model and serial number or use the contact form to make your request. Please indicate the complete model and serial number of your Scag product when requesting replacement manuals.

2.2 SIGNAL WORDS



This symbol means **“Attention! Become Alert! Your Safety is Involved!”** The symbol is used with the following signal words to attract your attention to safety messages found on the decals on the machine and throughout this manual. The message that follows the symbol contains important information about safety. To avoid injury and possible death, carefully read the message! Be sure to fully understand the causes of possible injury or death.

SIGNAL WORD:

It is a distinctive word found on the safety decals on the machine and throughout this manual that alerts the viewer to the existence and relative degree of the hazard.

DANGER

The signal word “DANGER” denotes that an extremely hazardous situation exists on or near the machine that could result in high probability of death or irreparable injury if proper precautions are not taken.

WARNING

The signal word “WARNING” denotes that a hazard exists on or near the machine that can result in injury or death if proper precautions are not taken.

CAUTION

The signal word “CAUTION” is a reminder of safety practices on or near the machine that could result in personal injury if proper precautions are not taken.

Your safety and the safety of others depends significantly upon your knowledge and understanding of all correct operating practices and procedures of this machine.

2.3 BEFORE OPERATION CONSIDERATIONS

1. NEVER allow children to operate this mower. Do not allow adults to operate this machine without proper instructions.
2. Do not mow when children and/or others are present. Keep children out of the mowing area and in the watchful care of a responsible adult other than the operator. Be alert and turn machine off if a child enters the area.
3. DO NOT allow children to ride or play on the machine, it is not a toy.
4. Clear the area to be mowed of objects that could be picked up and thrown by the cutter blades.
5. DO NOT carry passengers.
6. DO NOT operate the machine under the influence of alcohol or drugs.

7. If the operator(s) or mechanic(s) cannot read English, it is the owner's responsibility to explain this material to them.
8. DO NOT wear loose fitting clothing. Loose clothing, jewelry or long hair could get tangled in moving parts. Do not operate the machine wearing shorts; always wear adequate protective clothing including long pants. Wearing safety glasses, safety shoes and a helmet is advisable and is required by some local ordinances and insurance regulations.

WARNING

Always wear hearing protection. Operating this machine over prolonged periods of time can cause loss of hearing.

9. Keep the machine and attachments in good operating condition. Keep all shields and safety devices in place. If a shield, safety device or decal is defective or damaged, repair or replace it before operating the machine.

WARNING

This machine is equipped with an interlock system intended to protect the operator and others from injury. This is accomplished by preventing the engine from starting unless the deck drive is disengaged and the transmission is in neutral. The system shuts off the engine if the operator releases the operator presence levers with the deck drive engaged and/or the transmission is not in neutral. Never operate equipment with the interlock system disconnected or malfunctioning.

10. Be sure the interlock switches are functioning correctly.
11. Fuel is flammable; handle it with care. Fill the fuel tank outdoors. Never fill it indoors. Use a funnel or spout to prevent spillage. Clean up any spillage before starting the engine.
12. DO NOT add fuel to a running or hot engine. Allow the engine to cool for several minutes before adding fuel. Never fuel indoors or inside enclosed trailers.

13. Keep flammable objects (cigarettes, matches, etc.), open flames and sparks away from the fuel tank and fuel container. Use only approved containers.
14. See Section 7.4 ENGINE FUEL SYSTEM for fueling procedure.
15. Equipment must comply with the latest requirements per SAE J137 and/or ANSI/SAE S279 when driven on public roads.
16. Do not operate without the side discharge chute installed and in the down position or with an optional grass catcher or mulch plate completely installed.
17. Check the blade mounting bolts at frequent intervals for proper tightness.

2.4 OPERATION CONSIDERATIONS

1. Know the function of all controls and how to stop quickly.

WARNING

DO NOT operate on steep slopes. ALWAYS FOLLOW OSHA APPROVED OPERATION.

2. Reduce speed and exercise extreme caution on slopes and in sharp turns to prevent tipping or loss of control. Be especially cautious when changing directions on slopes.
3. To prevent tipping or loss of control, start and stop smoothly, avoid unnecessary turns and travel at reduced speed.
4. When using any attachment, never direct the discharge of material toward bystanders or allow anyone near the machine while in operation.
5. Start the engine when the neutral latches are in the neutral lock position, the cutter blades are disengaged, and the transmission is in neutral.
6. If the mower discharge ever plugs, shut off the engine, remove the ignition key, and wait for all movement to stop before removing the obstruction.

Section 2 **WARNING**

DO NOT use your hand to dislodge the clogged discharge chute. Use a stick or other device to remove clogged material after the engine has stopped running and the blades have stopped turning.

7. Be alert for holes, rocks, roots and other hidden hazards in the terrain. Keep away from any drop-offs. Beware of overhead obstructions (low limbs, etc.), underground obstacles (sprinklers, pipes, tree roots, etc.). Cautiously enter a new area. Be alert for hidden hazards.
8. Disengage power to cutter deck before backing up. Do not mow in reverse unless absolutely necessary and then only after observation of the entire area behind the mower. If you must mow in reverse, maintain a constant lookout to the rear of the machine and mow slowly.
9. DO NOT turn sharply. Use care when backing up.
10. Disengage power to cutter deck before crossing roads, walks or gravel drives.
11. Mow only in daylight or good artificial light.
12. NEVER raise the deck with the blades engaged.
13. Take all possible precautions when leaving the machine unattended, such as disengaging the mower, stopping the engine, and removing the key.
14. Disengage power to the attachments when transporting or when not in use.
15. The machine and attachments should be stopped and inspected for damage after striking a foreign object, and damage should be repaired before restarting and operating the machine.

 **CAUTION**

Do not touch the engine or the muffler while the engine is running or immediately after stopping. These areas may be hot enough to cause a burn.

 **DANGER**

DO NOT run the engine inside a building or a confined area without proper ventilation. Exhaust fumes are hazardous and contain carbon monoxide which can cause brain injury and death.

16. Keep hands and feet away from cutter blades and moving parts. Contact can injure.
17. Transport the mower using a heavy duty trailer or truck. Insure the trailer or truck has all of the necessary lighting and markings as required by laws, codes, and ordinances. Secure a trailer with a safety chain.
18. Be cautious when loading and unloading onto trailers or trucks. Use only a full width ramp.
19. When transporting the mower, make sure the transmission is in neutral, the neutral latches are in the neutral lock position, the engine is off with the key removed, and the wheels have been blocked.
20. Tie the mower down securely using straps, chains, cable, or ropes. Both front and rear straps must be directed down and outward from machine.
21. Use care when approaching blind corners, shrubs, trees, or other objects that may obscure vision.
22. NEVER leave the machine running unattended.

2.5 MAINTENANCE CONSIDERATIONS & STORAGE

1. Never make adjustments to the machine with the engine running unless specifically instructed to do so. If the engine is running, keep hands, feet, and clothing away from moving parts.
2. Place the transmission in neutral, neutral latches in the neutral lock position, stop engine and remove key or disconnect spark plug wire to prevent accidental starting of the engine when servicing or adjusting the machine. Wait for all movement to stop before adjusting, cleaning or repairing.
3. Remove spark plug wire before making any repairs.

4. Keep all nuts, bolts and screws tight, to ensure the machine is in safe working condition. Check blade mounting bolts frequently to be sure they are tight.
5. Do not change the engine governor settings or overspeed the engine. See the engine operator's manual for information on engine settings.
6. To reduce fire hazard, keep the cutting units, drives, muffler and engine free of grass, leaves, excessive grease, oil and dirt.
7. Park the machine on level ground.
8. NEVER allow untrained personnel to service the machine.
9. Use care when checking blades. Use a Blade Buddy, wrap the blade(s) or wear gloves and USE CAUTION when servicing blades. Only replace blades. NEVER straighten or weld blades.
10. Keep all parts in good working condition. Replace all worn or damaged decals.
11. Use jack stands to support components when required.
12. Carefully release pressure from components with stored energy.
13. Let the engine cool before storing.
14. DO NOT store the machine near an open flame.
15. Shut off fuel while storing or transporting.
16. DO NOT store fuel near flames or drain indoors.

2.6 USING A SPARK ARRESTOR

The engine in this machine is not equipped with a spark arrestor muffler. It is in violation of California Public Resource Code Section 4442 to use or operate this engine on or near any forest covered, brush covered or grass covered land unless the exhaust system is equipped with a spark arrestor meeting any applicable local or state laws. Other states or federal areas may have similar laws. Check with your state or local authorities for regulations pertaining to these requirements.

2.7 SPARK IGNITION SYSTEM

This spark ignition system complies with Canadian ICES-002.

Section 2

2.8 SAFETY AND INSTRUCTIONAL DECALS



483405



483402

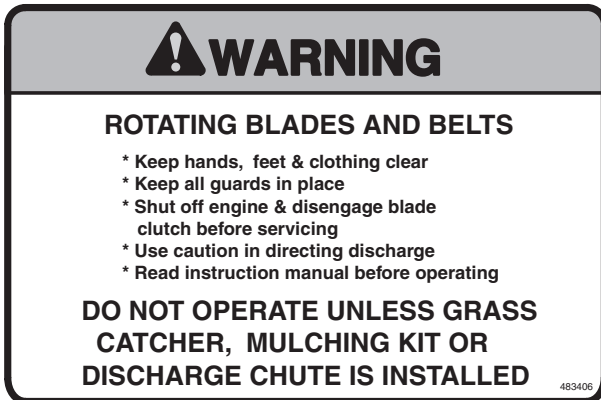

483406

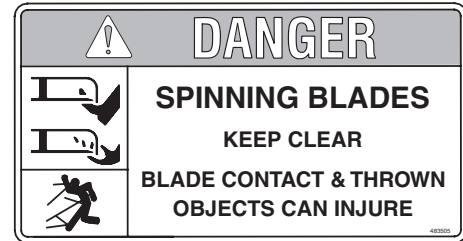

483505

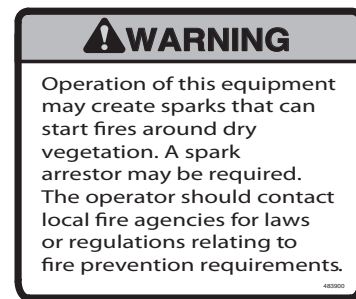

483900

(supplied with California models only)



483404

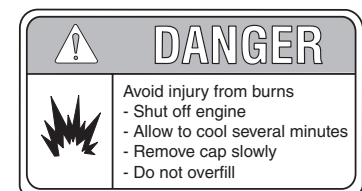

Molded in Fuel Tank

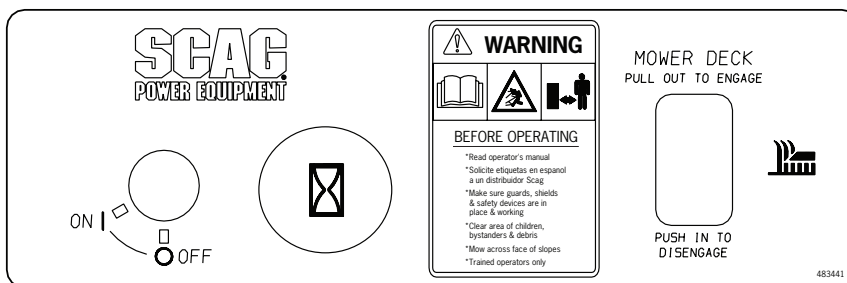

483441

2011 SW Safety Decals

SPECIFICATIONS

3.1 ENGINE

General Type	Heavy Duty Industrial/Commercial Gasoline
Brand	Kawasaki
Engine Model:	
(Scag Model SW32-481FS, SW36A-481FS, SW48V-481FS)	Kawasaki Model # FS481V
(Scag Model SW52V-541FS)	Kawasaki Model # FS541V
Displacement:	
Kawasaki FS481V	603cc
Kawasaki FS541V	603cc
Cylinders.....	2 with Cast-Iron Sleeves - Kawasaki
Governor.....	Mechanical Type with Variable Speed Control Set At 3600 RPM (+/- 100 RPM)
Idle Speed:	
Kawasaki	1550 RPM (+/- 150 RPM)
Fuel.....	Non-Leaded Gasoline with a Minimum Octane Rating of 87
Oil Pump.....	varies - see engine manufacturer's specifications
Starter:	
Kawasaki	Recoil Starter

3.2 ELECTRICAL

Starter.....	Electrical Ignition with Recoil Starter
Interlock Switches.....	Operator Presence, Mower Engagement (BBC), Transmission Neutral
Instrument Panel	Key Switch, Throttle Lever, PTO Switch,

3.3 ENGINE DECK

Drive System	Dual Belt Drive w/5-Speed Peerless Transmission
Steering/Travel Control	Clutch/Brake Fingertip Steering
Wheels:	
(2) Front Caster	9 X 3.5 Flat-Free w/Roller Bearings
(2) Drive -	15 x 6.5-6 Two-Ply Pneumatic Tubeless, Radius Edge
Tire Pressure:	
Front Caster.....	Flat-Free
Drive	12 PSI
Fuel Tank	5-1/2 Gallon Seamless Polyethylene Tank with Large Opening, Fuel Cap, Fuel Gauge and Cup Holder
Travel Speed:	
Forward	2 up to 6 MPH
Reverse	2 MPH
-NOTE- The machine will travel at 6 mph for transport purposes. For best cutting performance the forward travel speed should be adjusted depending upon the cutting conditions.	

Section 3

3.4 CUTTER DECK

Type	Out-Front design with anti-scalp rollers
Construction	7-Gauge Deck Top w/10-Gauge Reinforced Spindle Area, 7-gauge (3/16") Deck Skirt.
True Cutting Width:	
32	32" (81.3 cm)
36	35.5" (90.2 cm)
48	48" (122.0 cm)
52	52" (132.0 cm)
Cutting Height Adjustment.....	Adjustment from, 1-3/4" to 4-1/4" in 1/4" increments
Cutter Blades.....	0.197 in. Thick, Milled Edge, Wear Resistant Marbain™
Blade Engagement.....	Electric Blade Engagement Clutch with Control Panel Switch Connected to the Cutter Deck through a Belt.
Discharge Opening.....	Extra Wide Discharge Opening with Spring-Loaded Discharge Chute
Discharge Chute.....	Black, Polypropylene (Plastic), Flexible
Spindles.....	Cast-Iron Housing, Tapered Roller Bearings with Top Access Grease Fitting and Grease Overfill Relief Poppet
Spindle Pulleys.....	Split Steel with Tapered Locking Hub
Cutter Deck Belts.....	B-section with Kevlar Cord. Self-Adjusting, Self-Tightening
Electric Clutch Type	Ogura Heavy Duty PTO Clutch Brake

3.5 WEIGHTS AND DIMENSIONS

	32 / 36A	48V	52V
Length.....	70" / 72"	76"	76"
Tracking Width	32" / 37"	37"	37"
Overall Width w/chute down	43" / 47"	60.5"	64.5"
Overall Width w/chute up.....	33" / 37"	49"	53"
Overall Height.....	40.5 / 40.5"	40.5"	40.5"
Operating Weight.....	450# / 470#	515#	535#

3.6 PRODUCTIVITY

	32 / 36	48	52
Cutting Width	32" / 36"	48"	52"
Acres Per Day.....	8.3 / 9.3	12.4	13.5

The preceding data will aid you in determining how many acres your Scag mower will cut per day. It is an estimate based on 8 hours per day cutting time at 4 MPH with a 20% allowance for overlap and turns.

OPERATING INSTRUCTIONS

CAUTION

Do not attempt to operate this mower unless you have read this manual. Learn the location and purpose of all controls and instruments before you operate this mower.

4.1 CONTROLS AND INSTRUMENT IDENTIFICATION

Before operating the mower, familiarize yourself with all mower and engine controls. Knowing the location, function and operation of these controls is important for safe and efficient operation of the mower.

1. Ignition Switch (Figure 4-1). The ignition switch is used to start the engine. Turn the key to the on position before pulling the recoil starter.

- 2. Mower Deck Switch (Figure 4-1).** Used to engage and disengage the mower drive system. Pulling up on the switch will engage the deck drive. Pushing down on the switch will disengage the deck drive.
- 3. Engine Choke Control (Figure 4-1).** Used to start a cold engine.
- 4. Engine Throttle Control (Figure 4-1).** Used to control the engine speed. Pushing the lever forward increases engine speed. Pulling the lever back decreases engine speed. Full back position is the IDLE position. Full forward is the cutting position.
- 5. Left Steering / Brake Control (Figure 4-1).** Used to control the mower's left wheel when traveling forward or reverse. Pull upward to apply brake.
- 6. Right Steering / Brake Control (Figure 4-1).** Used to control the mower's right wheel when traveling forward or reverse. Pull upward to apply brake.

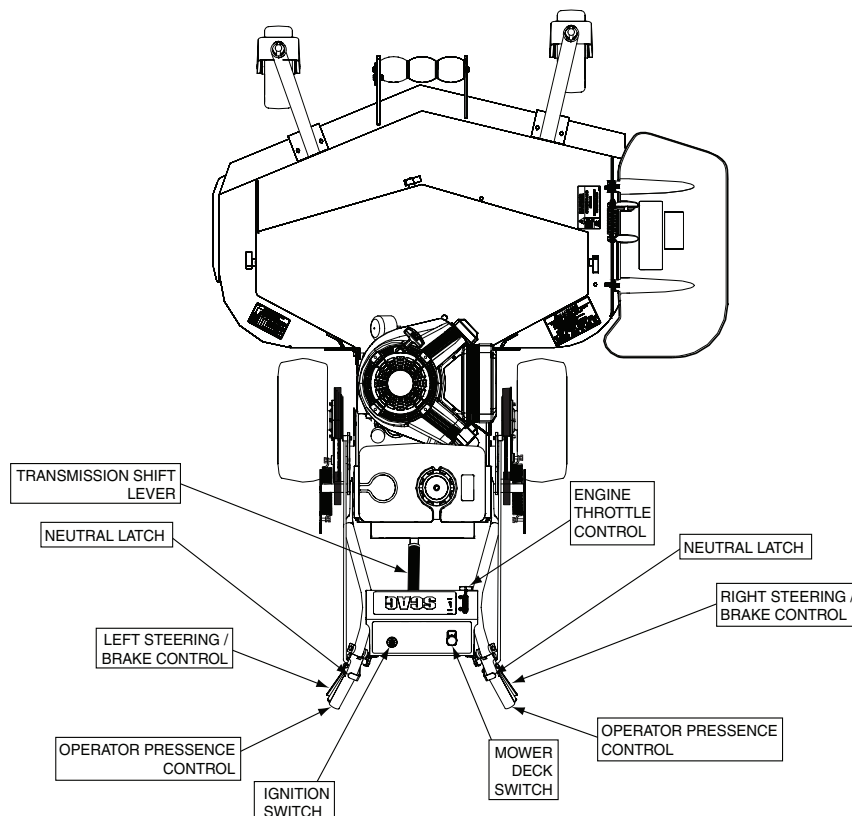

Figure 4-1. Controls and Instruments

Section 4

7. **Transmission Shift Lever (Figure 4-1).** Used to select the forward speed or selecting reverse. The machine must be at a complete stop before shifting between gears or shifting between forward and reverse.
8. **Neutral Latch (Figure 4-1).** Used to secure the belt drive system in neutral. Apply neutral latches when parking the machine.
9. **Operator Presence Control (Figure 4-1)**
The operator presence control levers must be depressed before the transmission is shifted out of neutral or engaging the mower deck.

4.2 SAFETY INTERLOCK SYSTEM

The mower is equipped with a safety interlock system that shuts off the engine if the operator releases the operator presence levers with the deck drive engaged and/or the transmission is not in neutral. Never operate equipment with the interlock system disconnected or malfunctioning.

WARNING

Never operate the mower with the interlock system disconnected or malfunctioning. Do not disengage or bypass any switch; injury to yourself and others or property damage could result.

4.3 INITIAL RUN-IN PROCEDURES

FIRST DAY OF USE OR APPROXIMATELY 20 HOURS

1. Check all belts for proper alignment and wear at 2, 4 and 8 hours.
2. Change the engine oil and oil filter after the first 20 hours of operation. (See Section 7.4.)
3. Check for loose hardware. Tighten as needed.
4. Check interlock system for proper operation. (See Section 4.2.)
5. Check tire pressure. Adjust pressure if necessary. (See Section 7.10.)

4.4 STARTING THE ENGINE

CAUTION

DO NOT USE STARTING FLUIDS. Use of starting fluids in the air intake system may be potentially explosive or cause a “runaway” engine condition that could result in engine damage and/or personal injury.

1. Be sure the fuel shutoff valve, located by the fuel tank, is completely open. (See Section 7.5.)
2. Apply the neutral latch levers.
3. Shift the transmission into neutral.
4. Place the PTO switch in the disengaged position.
5. If the engine is cold, choke the engine as needed.
6. Move the engine throttle control to about half engine speed.
7. Turn the ignition key to the ON position.
8. Pull the recoil starter on the engine.
9. Allow engine to warm before operating the mower.

4.5 GROUND TRAVEL AND STEERING

- IMPORTANT -

If you are not familiar with the operation of a walk behind mower with a transmission, the steering and ground speed operations should be learned and practiced in an open area, away from buildings, fences, or obstructions.

Learn the operation on flat ground before operating on slopes.

Start practicing with a slow engine speed and slow forward travel.

Learn to feather the steering controls to obtain a smooth operating action.

Practice operating the mower until you are comfortable with the controls before proceeding to mow.

FORWARD TRAVEL

To travel forward with the mower, select the desired speed using the transmission shift lever, pull steering / brake control levers upward, release the neutral latch for both sides and slowly release both the left and right steering / brake control levers. The higher the gear selected using the transmission shift lever, the faster the machine will travel.

To stop the forward travel, pull upward on the steering / brake control levers, lock the neutral latches and shift the transmission into neutral.

To steer the mower left while traveling forward, pull upward on the left steering / brake control lever. The further the lever is pulled upward, the quicker the mower will turn left.

To steer the mower right while traveling forward, pull upward on the right steering / brake control lever. The further the lever is pulled upward, the quicker the mower will turn right.

WARNING

To avoid serious bodily injury and damage to the transmission, the machine must be at a full stop before shifting between gears or shifting between forward and reverse.

- NOTE -

Smooth operation of the steering / brake control levers will produce smooth mower operation. While learning the operation of the steering controls, keep the travel speed low.

REVERSE TRAVEL

CAUTION

Disengage power to the mower before backing up. Do not mow in reverse unless absolutely necessary and then only after observation of the entire area behind the mower.

CAUTION

Before backing up, observe the rear for persons and obstructions. Clear the area before backing up. Possible injury or property damage could occur.

To travel in reverse, select the reverse gear using the transmission shift lever, pull steering / brake control levers upward, release the neutral latch for both sides and slowly release both the left and right steering / brake control levers. Keep the travel speed low while traveling in reverse.

- NOTE -

The mower may not travel straight in reverse.

To steer left while traveling in reverse, pull upward on the left steering / brake control lever. The further the lever is pulled upward, the quicker the mower will turn left.

To steer right while traveling in reverse, pull upward on the right steering / brake control lever. The further the lever is pulled upward, the quicker the mower will turn right.

To stop the reverse travel, pull upward on the steering / brake control levers, lock the neutral latches and shift the transmission into neutral.

4.6 ENGAGING THE DECK DRIVE (CUTTER BLADES)

1. Set the throttle at about 3/4 speed. Do not attempt to engage the deck drive at high speed as this shortens the electric clutch life — use only moderate engine speed when engaging the deck drive.
2. Engage the deck drive by pulling out on the yellow switch, located on the instrument panel, to the engage position. See Figure 4-2.

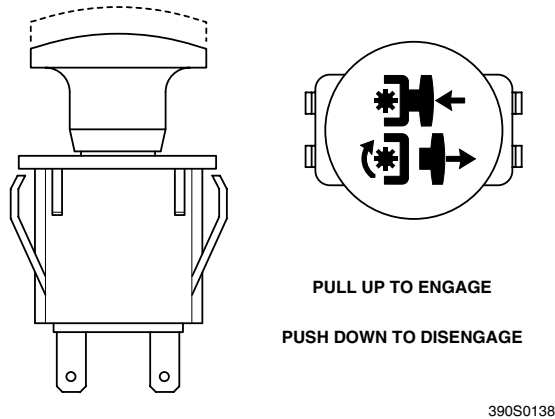

Figure 4-2. Cutter Engage Switch

- NOTE -

A squealing noise may be heard when engaging or disengaging the deck drive. It is caused by the electric clutch plates meshing as the mower comes up to speed. This is normal.

3. To disengage the deck drive, push the switch in to the disengage position.
4. Always operate the engine at full throttle to properly maintain cutting speed. If the engine starts to lug down, reduce the forward speed and allow the engine to operate at maximum RPM.

4.7 HILLSIDE OPERATION

WARNING

DO NOT operate on steep slopes. ALWAYS FOLLOW OSHA APPROVED OPERATION.

1. This mower has been designed for good traction and stability under normal mowing conditions. However, caution must be used when traveling on slopes, especially when the grass is wet. Wet grass reduces traction and steering control.
2. To prevent tipping or loss of control, do not start or stop suddenly, avoid unnecessary turns and travel at reduced speed. If tires lose traction, disengage blades and proceed slowly off the slope.
3. Avoid sudden starts when mowing on slopes.

4. Travel across the slope whenever possible. Never up and down the slope.
5. Keep tires properly inflated.

4.8 PARKING THE MOWER

1. Park the machine on a flat, level surface only. Do not park the machine on an incline.
2. Disengage the cutter blades.
3. Lock the neutral latches and shift the transmission into the neutral position.
4. Slow the engine to idle speed.
5. Turn the ignition key to the OFF position and remove the key.

4.9 AFTER OPERATION

1. Wash the entire mower after each use. Do not use high pressure spray or direct the spray onto electrical components.

- IMPORTANT -

Do not wash a hot or running engine. Cold water will damage the engine. Use compressed air to clean the engine if it is hot.

2. Keep the entire mower clean to inhibit serious heat damage to the engine or hydraulic oil circuit.
3. Check the drive belts for proper alignment and any signs of wear. Correct and adjust if necessary.

DANGER

To avoid injury from burns, allow the mower to cool before removing the fuel tank cap and refueling.

4. After the mower has cooled down, fill the fuel tank with fresh, clean fuel at the end of every day of operation. See Engine Owner's Manual for proper octane requirements.
5. Check the tire pressure. Adjust pressure if necessary.

4.10 REMOVING CLOGGED MATERIAL

DANGER

ROTATING BLADES

NEVER PUT YOUR HANDS INTO THE DISCHARGE CHUTE FOR ANY REASON!

Shut off the engine and remove the key and only then use a stick or similar object to remove material if clogging has occurred.

1. If the discharge chute becomes clogged, shut off the engine and remove the ignition key. Using a stick or similar item, dislodge the clogged material. Then resume normal mowing.

4.11 MOVING MOWER WITH ENGINE STOPPED

To “free-wheel” or move the mower around without the engine running, engage the neutral latches, shift the transmission to neutral and move the mower by hand.

4.12 RECOMMENDATIONS FOR MOWING

1. Do not mow with dull blades. A dull blade will tear grass, resulting in poor lawn appearance and reduced mowing power.

WARNING

DO NOT operate without Discharge Chute, Mulching Kit, or entire Grass Catcher properly installed.

2. The discharge chute must not be removed and must be kept in the lowest position to deflect grass clippings and thrown objects downward. Direct the side discharge away from sidewalks or streets to minimize cleanup of clippings. When mowing close to obstacles, direct the discharge away from the obstacles to reduce the chance of property damage by thrown objects.

3. Cut grass when it is dry and not too tall. Do not cut grass too short (cut off 1/3 or less of existing grass for best appearance). Mow frequently.
4. Keep mower and discharge chute clean.
5. When mowing wet or tall grass, mow the grass twice. Raise the mower to the highest setting for the first pass and then make a second pass to the desired height.
6. Use a slow travel speed for trimming purposes.
7. Operate the engine at full throttle for best cutting. Mowing with a lower RPM causes the mower to tear the grass. The engine is designed to be operated at full speed.
8. Use the alternate stripe pattern for best lawn appearance. Vary the direction of the stripe each time the grass is mowed to avoid wear patterns in the grass.

TROUBLESHOOTING CUTTING CONDITIONS

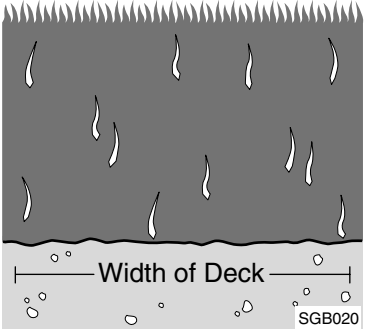
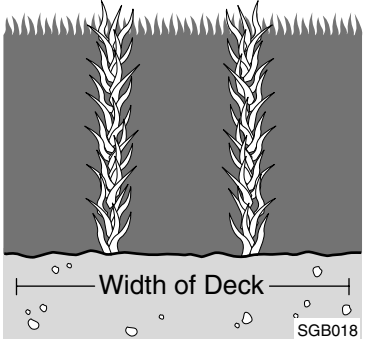
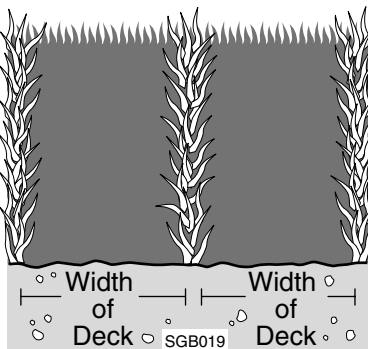
CONDITION	CAUSE	CURE
<p>STRINGERS - OCCASIONAL BLADES OF UNCUT GRASS</p> 	Low engine RPM	Run engine at full RPM
	Ground speed too fast	Slow speed to adjust for conditions
	Wet grass	Cut grass after it has dried out
	Dull blades, incorrect sharpening	Sharpen blades
	Deck plugged, grass accumulation	Clean underside of deck
	Belts slipping	Adjust belt tension
<p>STREAKING - STRIPS OF UNCUT GRASS IN CUTTING PATH</p> 	Dull, worn blades	Sharpen blades
	Incorrect blade sharpening	Sharpen blades
	Low engine RPM	Run engine at full RPM
	Belt slipping	Adjust belt tension
	Deck plugged, grass accumulation	Clean underside of deck
	Ground speed too fast	Slow speed to adjust for conditions
	Wet grass	Cut grass after it has dried out
	Bent blades	Replace blades
<p>STREAKING - STRIPS OF UNCUT GRASS BETWEEN CUTTING PATHS</p> 	Not enough overlapping between rows	Increase the overlap of each pass

TROUBLESHOOTING CUTTING CONDITIONS (CONT'D)

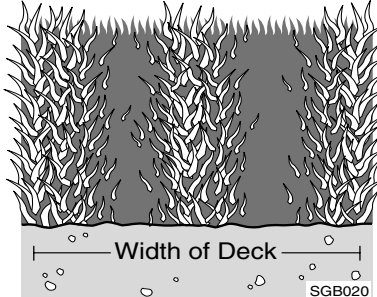
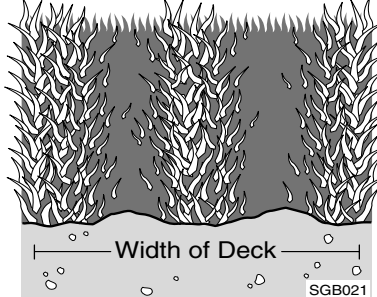
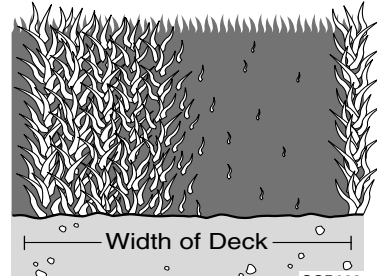
CONDITION	CAUSE	CURE
<p>UNEVEN CUT ON FLAT GROUND - WAVY HIGH-LOW APPEARANCE, SCALLOPED CUT, OR ROUGH CONTOUR</p>  <p style="text-align: right; font-size: small;">SGB020</p>	Lift worn from blade	Replace blade
	Blade upside down	Mount with cutting edge toward ground
	Deck plugged, grass accumulation	Clean underside of deck
	Too much blade angle (deck pitch)	Adjust pitch and level
	Deck mounted improperly	See your authorized SCAG dealer
	Bent spindle area	See your authorized SCAG dealer
	Dull blade	Sharpen blade
<p>UNEVEN CUT ON UNEVEN GROUND-WAVY APPEARANCE, HIGH-LOW SCALLOPED CUT, OR ROUGH CONTOUR</p>  <p style="text-align: right; font-size: small;">SGB021</p>	Uneven ground	May need to reduce ground speed, raise cutting height, and/or change direction of cut
<p>SLOPING RIDGE ACROSS WIDTH OF CUTTING PATH</p>  <p style="text-align: right; font-size: small;">SGB023</p>	Tire pressures not equal	Check and adjust tire pressure
	Wheels uneven	Check and adjust tire pressure
	Deck mounted incorrectly	See your authorized SCAG dealer
	Deck not level side-to-side	Check for level and correct

TROUBLESHOOTING CUTTING CONDITIONS (CONT'D)

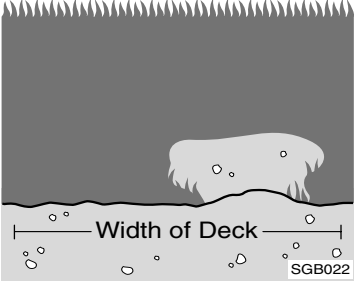
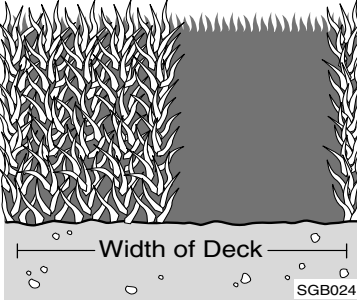
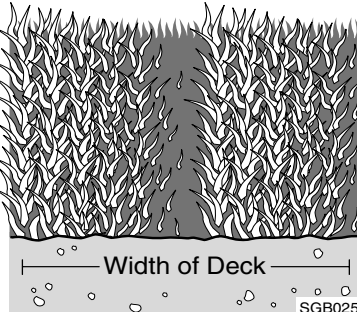
CONDITION	CAUSE	CURE
<p>SCALPING - BLADES HITTING DIRT OR CUTTING VERY CLOSE TO THE GROUND</p>  <p>Width of Deck SGB022</p>	Low tire pressures	Check and adjust pressures
	Ground speed too fast	Slow speed to adjust for conditions
	Cutting too low	May need to reduce ground speed, raise cutting height, change direction of cut, and/or change pitch and level
	Rough terrain	May need to reduce ground speed, raise cutting height, and/or change direction of cut
	Ground speed too fast	Slow speed to adjust for conditions
	Wet grass	Cut grass after it has dried out
<p>STEP CUT - RIDGE IN CENTER OF CUTTING PATH</p>  <p>Width of Deck SGB024</p>	Blades not mounted evenly	Adjust pitch and level
	Bent blade	Replace blade
	Internal spindle failure	See your authorized SCAG dealer
	Mounting of spindle incorrect	See your authorized SCAG dealer
<p>SLOPE CUT - SLOPING RIDGES ACROSS WIDTH OF CUTTING PATH</p>  <p>Width of Deck SGB025</p>	Bent spindle mounting area	See your authorized SCAG dealer
	Internal spindle failure	See your authorized SCAG dealer
	Bent deck housing	See your authorized SCAG dealer

ADJUSTMENTS

6.1 DRIVE CONTROL ADJUSTMENTS

1. Adjust the steering control rods so that there is approximately 3/4" clearance from the bottom of the rod to the bottom of the neutral latch slot when in the drive position. See Figure 6-1.
2. Adjust the steering brake rods so that the brakes do not apply until the steering levers are pulled tight to the handles. When the steering levers are locked in the neutral position the machine should move freely.

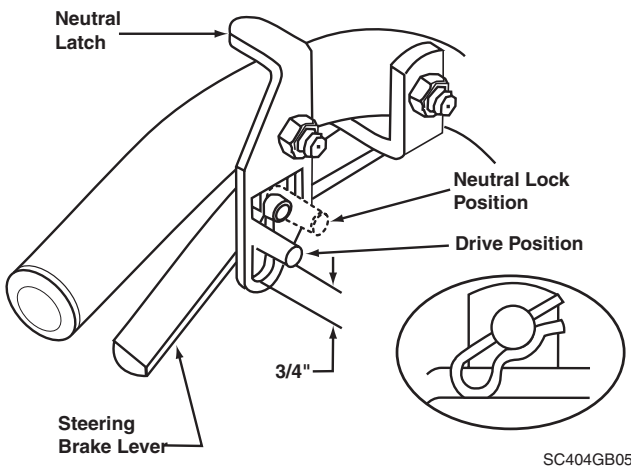

Figure 6-1. Steering Control Rod Adjustment

- NOTE -

Operator presence lever removed for clarity. Never operate equipment with the interlock system disconnected.

6.2 THROTTLE CONTROL AND CHOKE ADJUSTMENTS

These adjustments must be performed by your Scag dealer to ensure proper and efficient running of the engine. Should either need adjustment, contact your authorized Scag service center.

6.3 CUTTER DECK BELT ADJUSTMENTS

WARNING

Before removing any guards, shut the engine off and remove the ignition key. Wait for all moving parts to come to a complete stop before beginning work.

1. Remove the belt cover.
2. Adjust the cutter deck drive belt using a belt tension gauge. Adjust the belt so that the belt moves 1/2" with 10 pounds of pressure. Adjust the tension by tightening or loosening the J-bolt. See Figure 6-2.

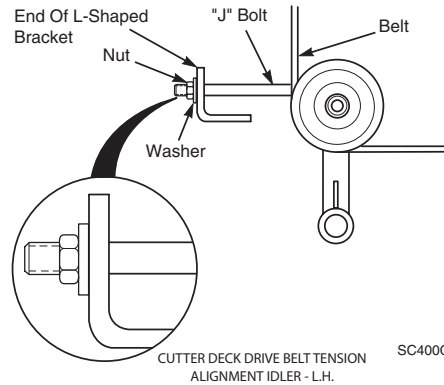

Figure 6-2. Deck Drive Belt Adjustment

-NOTE-

Due to initial belt stretch and to prevent the belt from slipping, check this adjustment after the first 2 hours, 4 hours and 8 hours of operation.

3. Adjust the RH blade drive belt using a belt tension gauge. Adjust the belt so that the belt moves 1/2" with 10 pounds of pressure. Adjust the tension by tightening or loosening the J-bolt. See Figure 6-3 and Figure 6-4.

Section 6

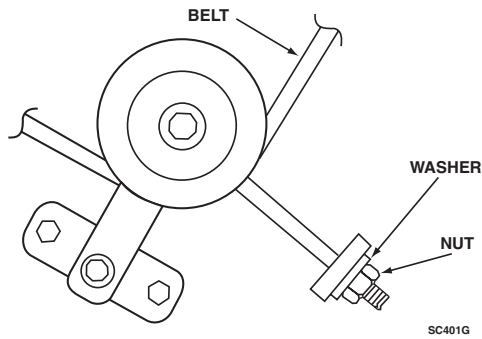

Figure 6-3. Cutter Deck Belt Adjustment R.H.

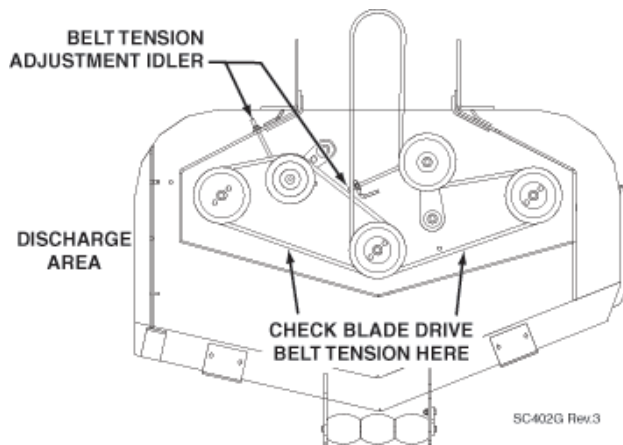

Figure 6-4. Cutter Deck Belt

6.4 BELT ALIGNMENT

Belt alignment is important for proper performance of your Scag mower. If you experience frequent belt wear or breakage, see your authorized Scag service center for belt adjustment.

6.5 ADJUSTING CUTTING HEIGHT

The mower deck can be adjusted from a height of 1-3/4 inches to 4-1/4 inches at 1/4-inch intervals.

Due to many cutting conditions that exist, it is difficult to suggest a cutter deck setting that will work for every lawn. There are two adjustments that can be made to the cutter deck, pitch and height.

PITCH is the angle of the blades (comparing front to rear).

HEIGHT is the nominal distance the blade is off of the ground. This measurement is made with the blades pointed side to side and distance is measured between the cutting tip and ground. (Also see Blade Height Adjustment).

Changes to the cutting height can be achieved by repositioning the cutter deck. (This adjustment will also effect the pitch of the deck). There are three available positions. See Figure 6-5.

Caster spacers also can be repositioned to change the cutting heights and to change the pitch of the cutter deck. See Figure 6-6.

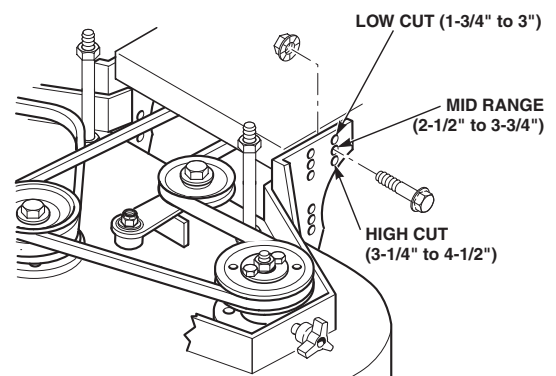

Figure 6-5. Adjusting Cutting Height

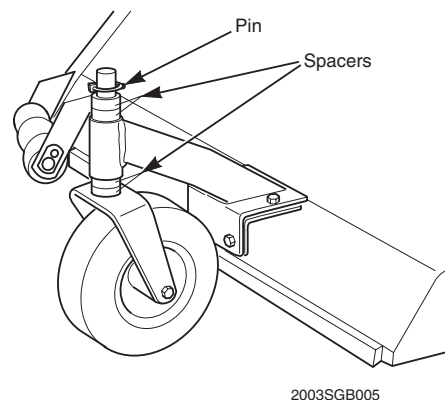

Figure 6-6. Cutting Height Decal

BLADE HEIGHT ADJUSTMENT

Adjusting the blade height can be done by moving any number of the five smaller 1/4" spacers on the blade mounting bolts to the top of the spindle shaft or below the spindle shaft.

-NOTE-

All blades should be positioned equally.

WARNING

Blades have a sharp cutting edge. Wear proper eye protection and protective gloves or wrap the blades with protective material when removing, sharpening and installing blades.

For best cut and discharge, a minimum of three spacers should be installed between the blade and the spindle. See Figure 6-7.

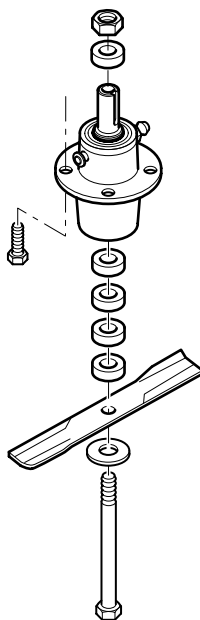

2002 SC407G

Figure 6-7. Blade Spacers

CUSTOM-CUT BAFFLE ADJUSTMENT

The Custom-Cut Baffle is designed to deliver optimum airflow and superior cutting performance in any type of grass. The Custom-Cut Baffle can be raised or lowered to precisely tailor the deck's performance for the type of grass being cut. The baffle can be set in seven (7) different positions for optimum performance.

- A. 3-1/2" or 3-3/4" Position - (See Figure 6-8). For very tall, wiry or tough-to-cut grass.
- B. 4" (factory setting), 4-1/4" or 4-1/2" Position - (See Figure 6-8). For general purpose cutting. This gives the best mix of cutting performance in all types of grass.
- C. 4-3/4" or 5-1/4" Position - (See Figure 6-8). Placing the baffle in either the 4-3/4" or 5-1/4" setting will enhance fall cutting (leaf pickup) and reduce cutter deck "blowout".

To adjust the Custom-Cut Baffle height:

1. Place the cutter deck in the transport position.
2. Remove the hardware securing the Custom-Cut Baffle to the cutter deck.

- NOTE -

Hardware location used in the illustrations are for reference only. Location of hardware may vary depending on cutter deck size.

3. Move the Custom-Cut Baffle to desired position. (See Figures 6-8).
4. Reinstall the mounting hardware. Torque hardware to 39 ft-lbs.

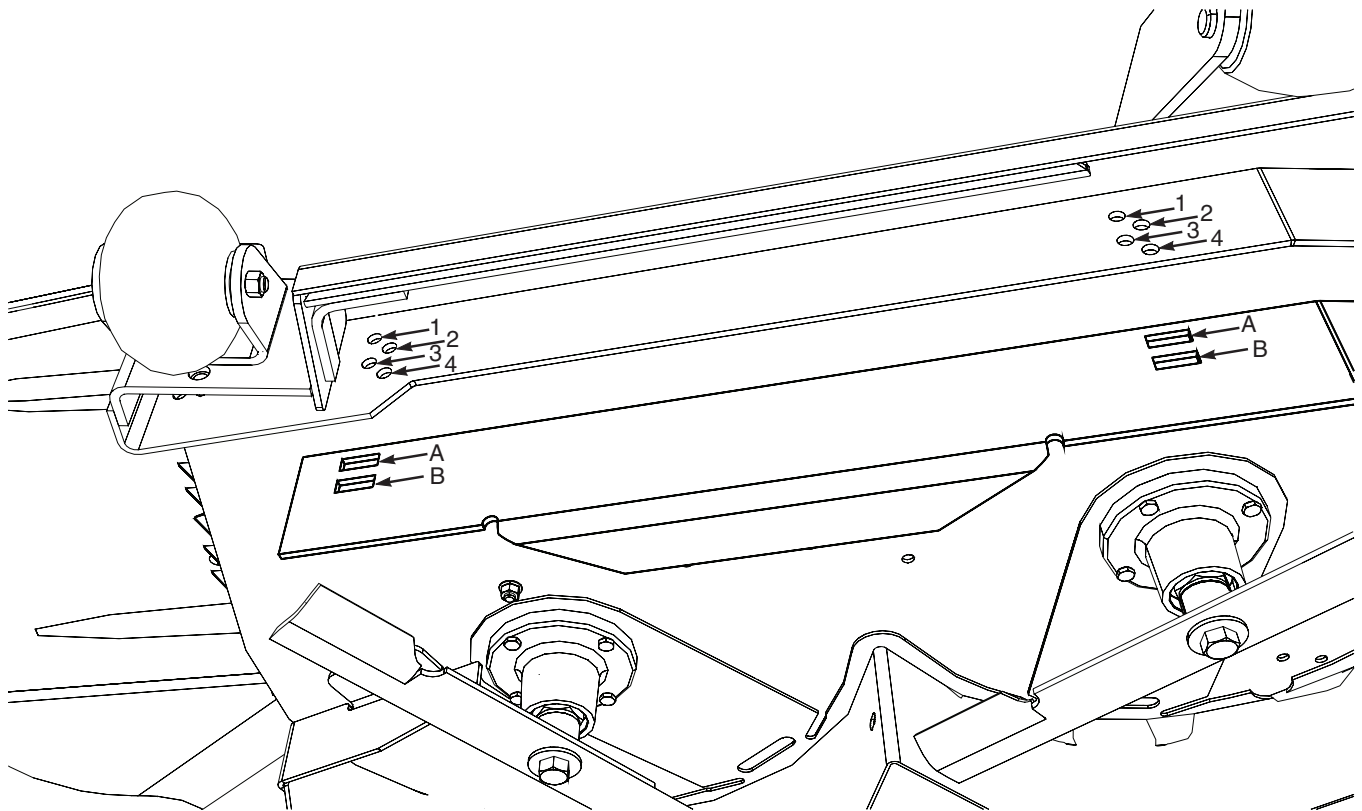

Custom-Cut Baffle Adjustment

Mounting Slot Selected	Mounting Hardware Location			
	Hole 1	Hole 2	Hole 3	Hole 4
Slot "A"				
Height (inches)	3-3/4"	4-1/4"	4-3/4"	5-1/4"
Slot "B"				
Height (inches)		3-1/2"	4"	4-1/2"

Figure 6-8. Custom-Cut Baffle Adjustment

6.6 ELECTRIC CLUTCH ADJUSTMENT

The electric clutch serves two functions in the operation of the mower. In addition to starting and stopping the power flow to the cutter blades, the clutch also acts as a brake to assist in stopping blade rotation when the PTO is switched off or the operator presence circuit is interrupted.

When the clutch is disengaged, the air gap between the armature and rotor must be adjusted to fifteen thousandths of an inch, 0.015, for proper operation. The airgap adjustment is made at three bolts on the clutch. There are three inspection windows, one next to each adjusting bolt. See Figure 6-9.

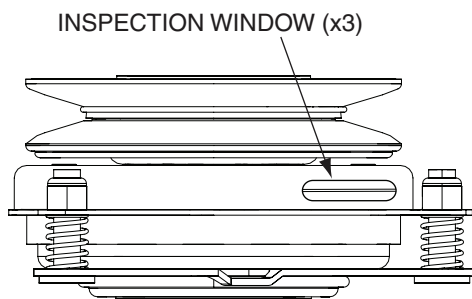

Figure 6-9. Clutch Air Gap Adjustment

1. Locate the inspection windows on the clutch.
2. Place a 0.015 feeler gauge in the slot between the rotor and the armature. See Figure 6-10.

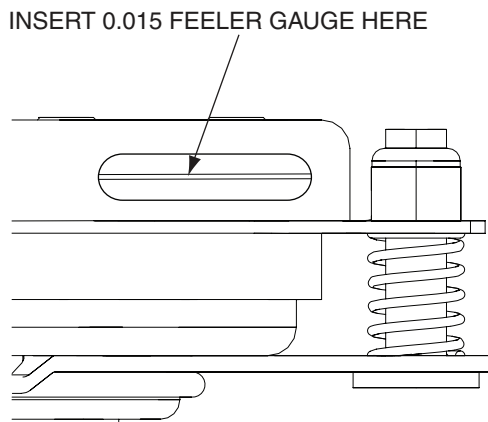

Figure 6-10. Clutch Air Gap Adjustment

3. Tighten or loosen the adjusting bolt as needed to achieve the 0.015 inch airgap. See Figure 6-11. Perform this operation at all three inspection windows.

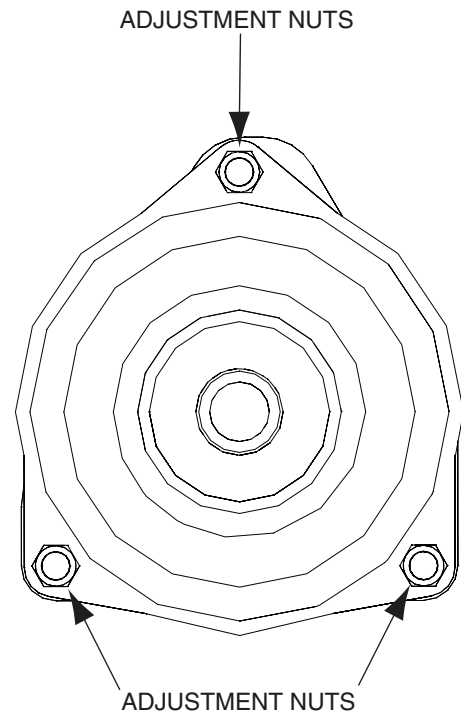

Figure 6-11. Clutch Air Gap Adjustment

This adjustment should be done every 500 hours of operation or annually, whichever comes first. In cases where the machine is heavily used, airgap settings should be checked more often.

If the air gap is too narrow, the clutch armature may drag when disengaged, resulting in premature failure.

If the air gap is too wide, the clutch may be slow to engage as the magnet must pull the armature in from a greater distance.

MAINTENANCE

7.1 MAINTENANCE CHART - RECOMMENDED SERVICE INTERVALS

BREAK-IN (FIRST 10)	HOURS						PROCEDURE	COMMENTS
	8	20	40	100	200	500		
X							Check all hardware for tightness	
X							Check all belts for proper alignment	See paragraph 7.6
	X						Check engine oil level	See paragraph 7.3
	X						*Clean mower	
	X						Check tire pressure	See paragraph 7.8
	X						*Clean air filter element	See paragraph 7.5
	X						Check condition of blades	See paragraph 7.7
	X						Sharpen cutter blades	See paragraph 7.7
	X						Check tire pressure	See paragraph 7.10
	X						Check belt tension	See paragraph 6.3
	X						Check the operator interlock system	See paragraph 4.2
		X					Change engine oil and filter	See paragraph 7.3
			X				Grease spindle bearings	
			X				Check belts for proper alignment	See paragraph 7.6
				X			Check condition of fuel lines	
				X			Check all belts for proper alignment	
				X			*Replace engine air filter	See engine operator's manual
				X			Grease caster wheel bearings	See paragraph 7.2
				X			Grease transmission couplers	See paragraph 7.2
				X			Check all hardware for tightness	
				X			Change engine oil	See paragraph 7.3
				X			*Clean air cleaner element	See paragraph 7.5

* Perform these maintenance procedures more frequently under extreme dusty or dirty conditions

MAINTENANCE CHART - RECOMMENDED SERVICE INTERVALS (CONT'D)

BREAK-IN (FIRST 10)	HOURS					PROCEDURE	COMMENTS
	8	40	100	200	500		
				X		Check hardware for tightness	
				X		Change engine oil filter	See paragraph 7.3
					X	Replace engine fuel filter	See paragraph 7.3
					X	Grease caster wheel pivot shafts	See paragraph 7.2
					X	Adjust electric PTO clutch	See paragraph 6.6

7.2 LUBRICATION

GREASE FITTING LUBRICATION CHART

LOCATION	LUBRICATION INTERVAL	LUBRICANT	NO. OF PLACES
1 - Caster Wheel Pivot	100 Hours / Bi-Weekly	Chassis Grease	2
2 - Caster Wheel Bearings	100 Hours/Monthly	Chassis Grease	2
3 - Cutter Deck Spindles	40 Hours / Weekly	+ US Lithium MP White Grease	2 / 3
4 - Transmission Couplers	100 Hours / Monthly	Chassis Grease	2
5 - Wheel Bearings	100 Hours / Bi-Weekly	Chassis Grease	2
6 - Idler Arm Pivot	100 Hours / Bi-Weekly	Chassis Grease	2

GREASE FITTING LUBRICATION

LUBRICANT / INTERVAL

- LITHIUM MP WHITE GREASE 2125
(40 HOURS / WEEKLY)
- CHASSIS GREASE
(100 HOURS / BI-MONTHLY)
- ⬡ CHASSIS GREASE
(200 HOURS / MONTHLY)

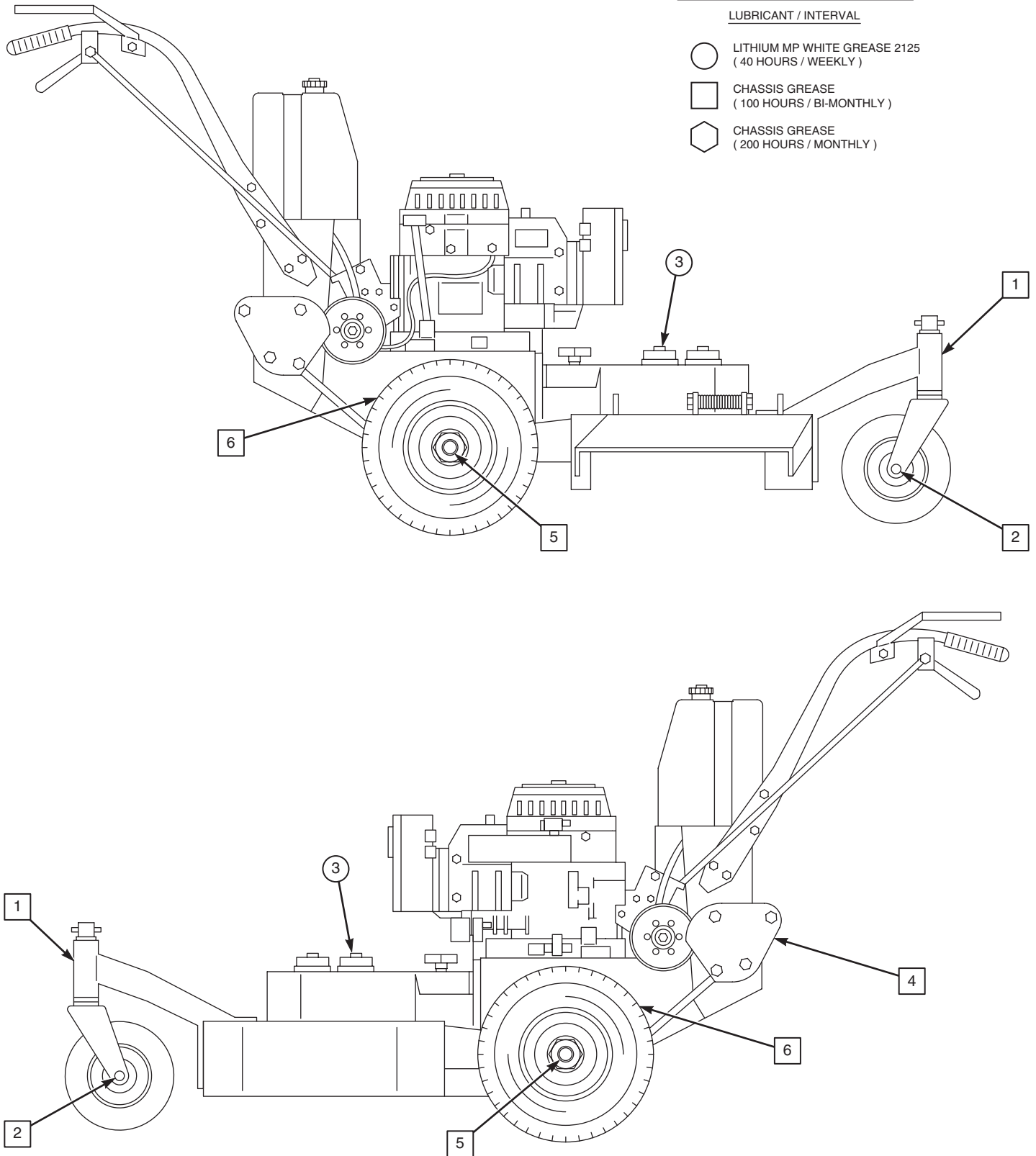

Figure 7-1. Lubrication Fitting Points

390S0178

7.3 ENGINE OIL

A. CHECKING ENGINE CRANKCASE OIL LEVEL

The engine oil level should be checked after every 8 hours of operation or daily as instructed in the Engine Operator's Manual furnished with this mower.

B. CHANGING ENGINE CRANKCASE OIL

After the first 20 hours of operation, change the engine crankcase oil and replace the oil filter. Thereafter, change the engine crankcase oil after every 100 hours of operation or bi-weekly, whichever occurs first. Refer to the Engine Operator's Manual furnished with this mower for instructions.

C. CHANGING ENGINE OIL FILTER

After the first 20 hours of operation, replace the engine oil filter. Thereafter, replace the oil filter after every 200 hours of operation or every month, whichever occurs first. Refer to Engine Operator's Manual for instructions.

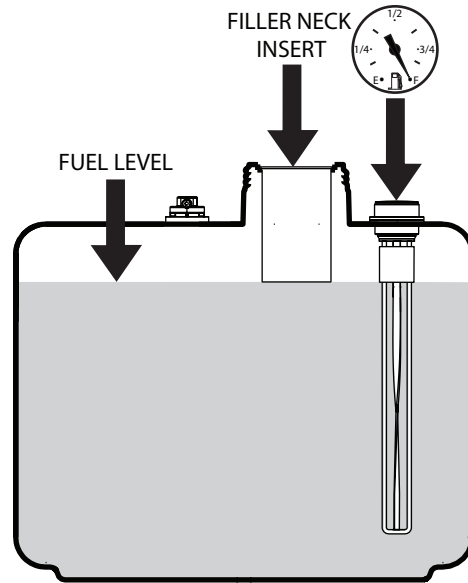

Figure 7-2. Fuel Level

7.4 ENGINE FUEL SYSTEM

⚠ DANGER

To avoid injury from burns, allow the mower to cool before removing the fuel tank cap and refueling.

A. FILLING THE FUEL TANK

Fill the fuel tank at the beginning of each operating day. Fill to the bottom of the filler neck insert (approximately 5-1/2 gallons indicating Full (F) on the fuel gauge) at the beginning of each operating day. See Figure 7-2. Do not overfill. Use clean, fresh unleaded gasoline with a minimum octane rating of 87 and a maximum of 10% Ethanol.

DO NOT use E85 Fuel. Using E85 Fuel will cause severe damage to the engine.

To avoid personal injury or property damage, use extreme care in handling gasoline. Gasoline is extremely flammable and the vapors are explosive.

1. Extinguish all cigarettes, cigars, pipes and other sources of ignition.
2. Use only an approved gasoline container.
3. Never remove the gas cap or add fuel with the engine running. Allow the engine to completely cool before fueling.
4. Never fuel the machine indoors or in an enclosed trailer.
5. Never store the machine or fuel container where there is an open flame, spark or pilot light such as on a water heater or other appliances.
6. Never fill containers inside a vehicle or on a truck or trailer bed with a plastic liner. Always place containers on the ground away from your vehicle before filling.
7. Remove the machine from the truck or trailer and fuel on level ground. If this is not possible, then refuel the machine with a portable container, rather than from a gasoline dispenser nozzle.
8. Keep the nozzle in contact with the rim of fuel tank or container opening at all times until fueling is complete. Do not use a nozzle lock-open device.
9. If fuel is spilled on clothing, change clothing immediately and wash affected skin.

Section 7

10. Replace gas cap and tighten securely. For Low Emission (LE) and EPA Phase 3 (produced after 1/1/2011) models, tighten the fuel cap until it ratchets.

B. REPLACING IN-LINE FUEL FILTER ELEMENTS

The engine fuel filter should be replaced after every 500 hours of operation or annually, whichever occurs first.

1. Close the shut-off valve.
2. Remove and replace the engine fuel filter. Open the fuel shut-off valve.

7.5 ENGINE AIR CLEANER

A. CLEANING AND/OR REPLACING AIR CLEANER ELEMENT

For any air cleaner, the operating environment dictates the air cleaner service periods. Inspect and clean the air cleaner element after every 100 hours of operation or bi-weekly, whichever occurs first and replace the element if required.

- NOTE -

In extremely dusty conditions it may be necessary to check the element once or twice daily to prevent engine damage.

1. Remove the air cleaner cover. Set aside.
2. Remove the air cleaner and inspect.
3. Clean or replace the air cleaner and foam pre-cleaner as recommended by the engine manufacturer.
4. Replace the air cleaner cover and secure.

7.6 CUTTER BLADES

A. BLADE INSPECTION

1. Remove the ignition key before servicing the blades.

 **WARNING**

Always wear proper hand and eye protection when working with cutter blades.

2. Check the cutter blades for straightness. If the cutter blades appear bent, they will need to be replaced.
3. Check the cutter blades for wear. If any part of the cutter blade is worn to 1/2 its original thickness, replace the cutter blade.

 **WARNING**

Do not attempt to straighten a bent blade, and never weld a broken or cracked blade. Always replace it with a new blade to assure safety.

4. Check the cutter blades for gouges. If there are gouges on the top or bottom surfaces of the cutter blade, replace the cutter blade.
5. If a blade cutting edge is dull or nicked, it should be sharpened. Remove the blades for sharpening. See "Blade Replacement."

- NOTE -

Keep the blades sharp. Cutting with dull blades not only yields a poor mowing job, but slows the cutting speed of the mower and causes extra wear on the engine and the blade drive by pulling hard.

B. BLADE SHARPENING

- NOTE -

If possible, use a file to sharpen the blade. Using a wheel grinder may burn the blade.

- NOTE -

DO NOT sharpen the blades beyond 1/3 of the width of the blade. See Figure 7-3.

1. Sharpen the cutting edge at the same bevel as the original. See Figure 7-3. Sharpen only the top of the cutting edge to maintain sharpness.

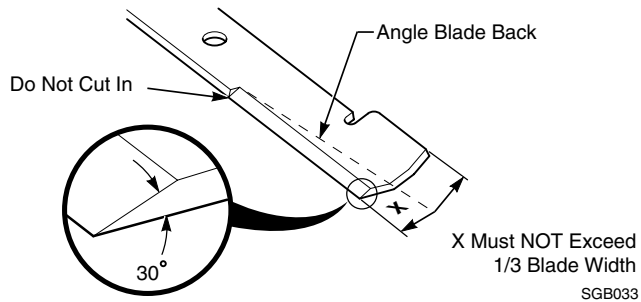

Figure 7-3. Blade Sharpening

2. Check the balance of the blade. If the blades are out of balance, vibration and premature wear can occur. The cutter blades should be balanced to 1-1/2 oz-in. See your authorized Scag dealer for blade balancing or special tools, if you choose to balance your own blades.

C. BLADE REPLACEMENT

WARNING

Always wear proper hand and eye protection when working with cutter blades.

1. Remove the ignition key before replacing the blades.
2. Remove the belt cover.
3. Secure the cutter blades to prevent them from rotating, (use the optional Blade Buddy tool P/N 9212, to assist in securing the cutter blades), remove the blade attaching bolt. Remove the cutter blade, bolt, lockwasher and flatwasher from the spindle shaft. See Figure 7-4.

- NOTE -

Be sure that the blade is installed with the lift wing towards the top of the cutter deck.

CAUTION

Inspect the cutter blade spacer(s) and washer for wear and/or cupping. Replace the worn parts. Worn spacer(s) and/or washer will not allow proper tightening of the cutter blade and can lead to cutter blade failure, personal injury or property damage.

4. Install the cutter blade on to the cutter spindle shaft. Secure the blades from rotating and torque to 75 ft/lbs. See Figure 7-4.
5. Install the belt cover.

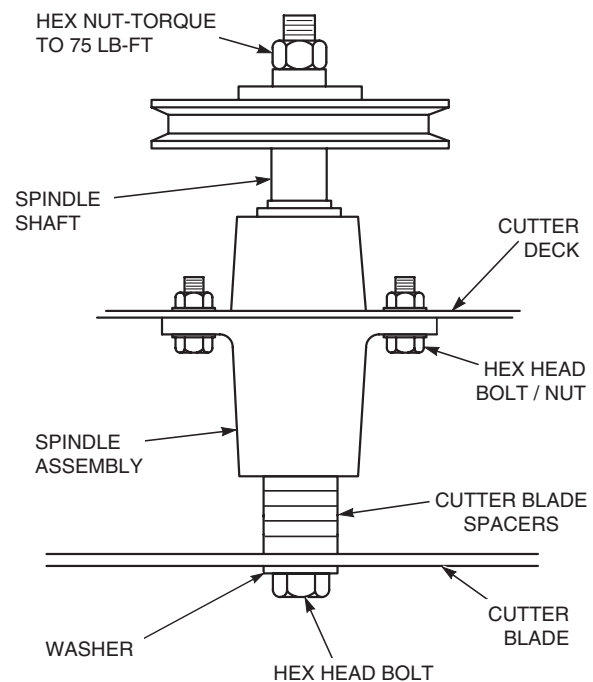

Figure 7-4. Blade Replacement

7.7 TIRES

Check the tire pressures after every 8 hours of operation or daily.

Caster Wheels
Drive Wheels

Flat-Free
12 PSI

ILLUSTRATED PARTS LIST

8.1 SCAG APPROVED ATTACHMENTS AND ACCESSORIES.

Attachments and accessories manufactured by companies other than Scag Power Equipment are not approved for use on this machine.

Scag approved attachments and accessories:

- Mulch Plate (p/n 9258, 9286, 9287)
- Hurricane Mulch (p/n 9263, 9283, 9284)
- GC-4D (p/n 9054)
- GC-F4 (p/n 9055)
- Blade Buddy (p/n 9212)
- Hour Meter (p/n 48023)
- Turbo Baffle (p/n 424208)

32" & 36A CUTTER DECKS

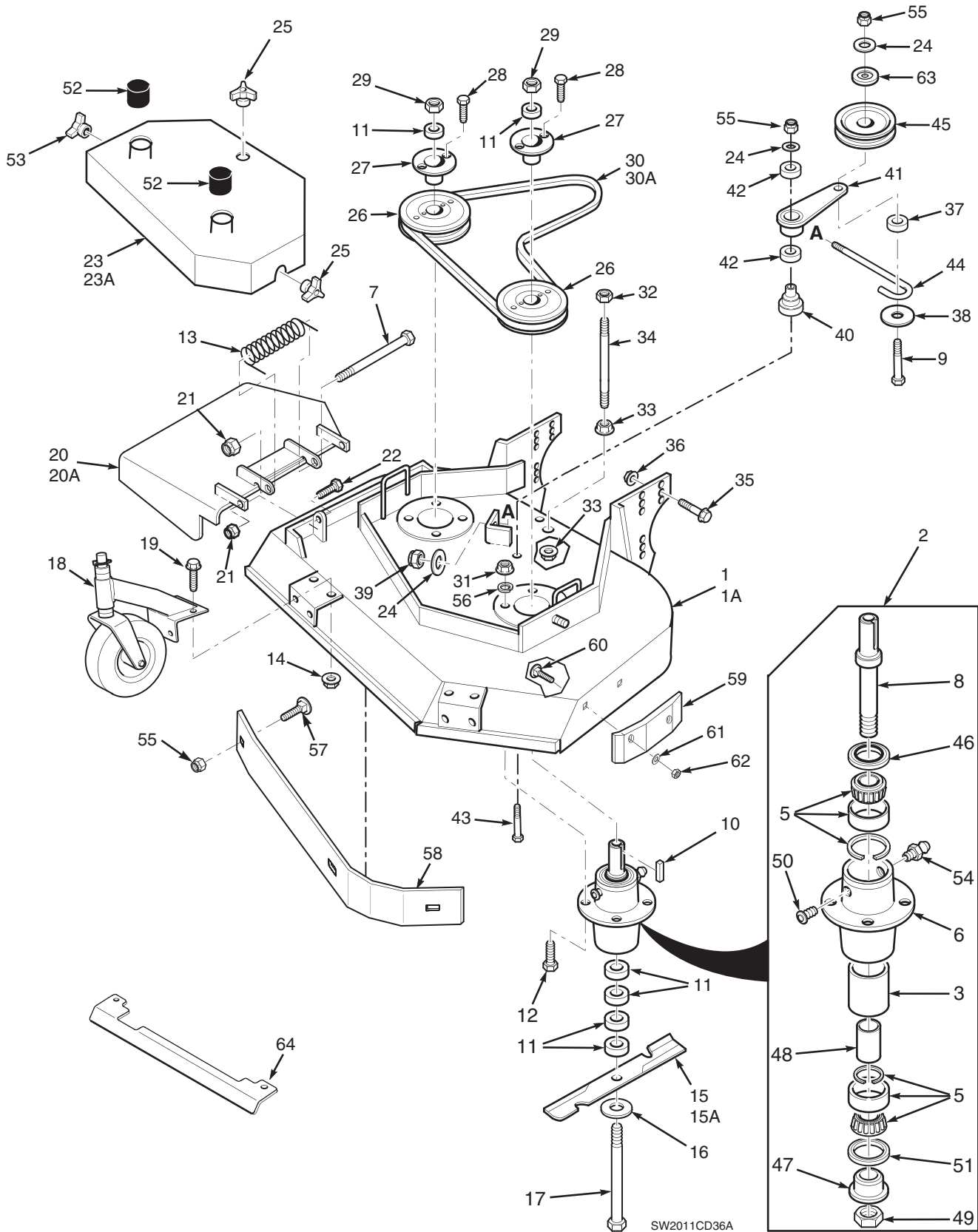

32" & 36A CUTTER DECKS

Ref. No.	Part No.	Description	32	36	Ref. No.	Part No.	Description	32	36
1	461847	Cutter Deck w/Decals	x		45	483215	Idler Pulley, Belt Clutch	x	x
1A	461848	Cutter Deck w/Decals		x	46	481024	Seal, Cutter Spindle	x	x
2	461663	Cutter Spindle Assembly	x	x	47	43297	Spindle Bushing	x	x
3	43312	Spacer, Outside	x	x	48	43296	Spacer, Inside	x	x
5	481022	Bearing, Tapered	x	x	49	481035	Nut, 1.06-18	x	x
6	43644	Spindle Housing	x	x	50	48677	Relief Fitting, Cutter Spindle	x	x
7	04001-154	Bolt, 5/16-18 x 4-3/4"	x	x	51	481025	Seal, Cutter Spindle	x	x
8	43589	Spindle Shaft	x	x	52	484368	Spindle Shield	x	x
9	04001-51	Bolt, 3/8-16 x 3-3/4" Hex Head	x	x	53	04029-04	Wing Nut, 3/8-16 (Small) RH side	x	x
10	04063-08	Key, 1/4 x 1/4 x 2"	x	x	54	48114-04	Grease Fitting	x	x
11	43592	Spacer, Cutter Blade - Small	x	x	55	04021-09	Nut, Hex Elastic Stop 3/8-16	x	x
12	04001-175	Bolt, 5/16-18 x 1-1/2" Hex Head Grade 8	x	x	56	04030-03	Lock Washer, 5/16"	x	x
13	482245	Spring, Chute Return	x	x	57	04003-23	Bolt, Carriage 3/8-16 x 1"	x	x
14	04019-03	Nut 5/16-18 Serrated Flange	x	x	58	423783	Baffle Weldment		x
15	481706	Cutter Blade, 16-1/2"	x		59	483174	Pad, Deck Wear	x	x
	481707	Cutter Blade, 18"		x	60	04003-12	Bolt, Carriage 5/16-18 x 3/4"	x	x
15A	481710	Cutter Blade 16-1/2 Hi-Lift	x		61	04040-04	Flatwasher, 5/16"	x	x
	481711	Cutter Blade, 18 Hi-Lift		x	62	04021-04	Hex Nut, 5/16-18 Center Locknut	x	x
16	04043-06	Flatwasher, 5/8 W	x	x	63	424367	Dust Shield	x	x
17	04001-41	Hex Hd. Bolt, 5/8-11 x 9-1/2"	x	x	64	424661	Heatshield	x	x
18	461023	Caster Assembly	x	x					
19	04017-16	Cpscrw, 5/16-18 x 3/4" Ser. Fig. Hex Head	x	x					
20	46	Discharge Chute	x						
20A	46	Discharge Chute		x					
21	04021-10	Hex Nut, 5/16-18 Elastic Stop	x	x					
22	04001-09	Hex Hd Bolt, 5/16-18 x 1"	x	x					
23	462392	Belt Cover Assy (Incl. Decal)	x						
23A	462393	Belt Cover Assy (Incl. Decal)		x					
24	04043-04	Flat Washer, 3/8" Special	x	x					
25	04029-03	Wing Nut, 3/8-16	x	x					
26	482744	Pulley	x	x					
27	48926	Tapered Hub	x	x					
28	04001-172	Hex Hd. Bolt, 1/4-20 x 1"	x	x					
29	04020-09	Hex Nut, 5/8-11	x	x					
30	48278	Belt, Blade Drive	x						
30A	48204	Belt, Blade Drive		x					
31	04021-22	Elastic Stop Nut, 5/16-18 Grade 8	x	x					
32	04021-05	Hex Nut, 3/8-16 Center Locknut	x	x					
33	04019-04	Nut, 3/8-16 Serrated Flange	x	x					
34	04004-02	Support, Belt Cover	x	x					
35	04017-36	Cpscrw, 1/2-13 x 1" Ser. Fig. HH	x	x					
36	04112-05	Nut, 1/2-13 Spirallock	x	x					
37	43277	Spacer, J-Hook	x	x					
38	04041-12	Flatwasher, 3/8 x 1-1/2 x 16 GA	x	x					
39	04021-09	Elastic Stop Nut, 3/8-16	x	x					
40	43681	Idler Pivot	x	x					
41	461841	Idler Arm Assy. (Inc. 42)	x	x					
42	48224	Bearing	x	x					
43	04001-62	Cpscrw, 3/8-16 x 3-1/4" Hex Head	x	x					
44	44078	J-Hook	x	x					

48V & 52V CUTTER DECKS

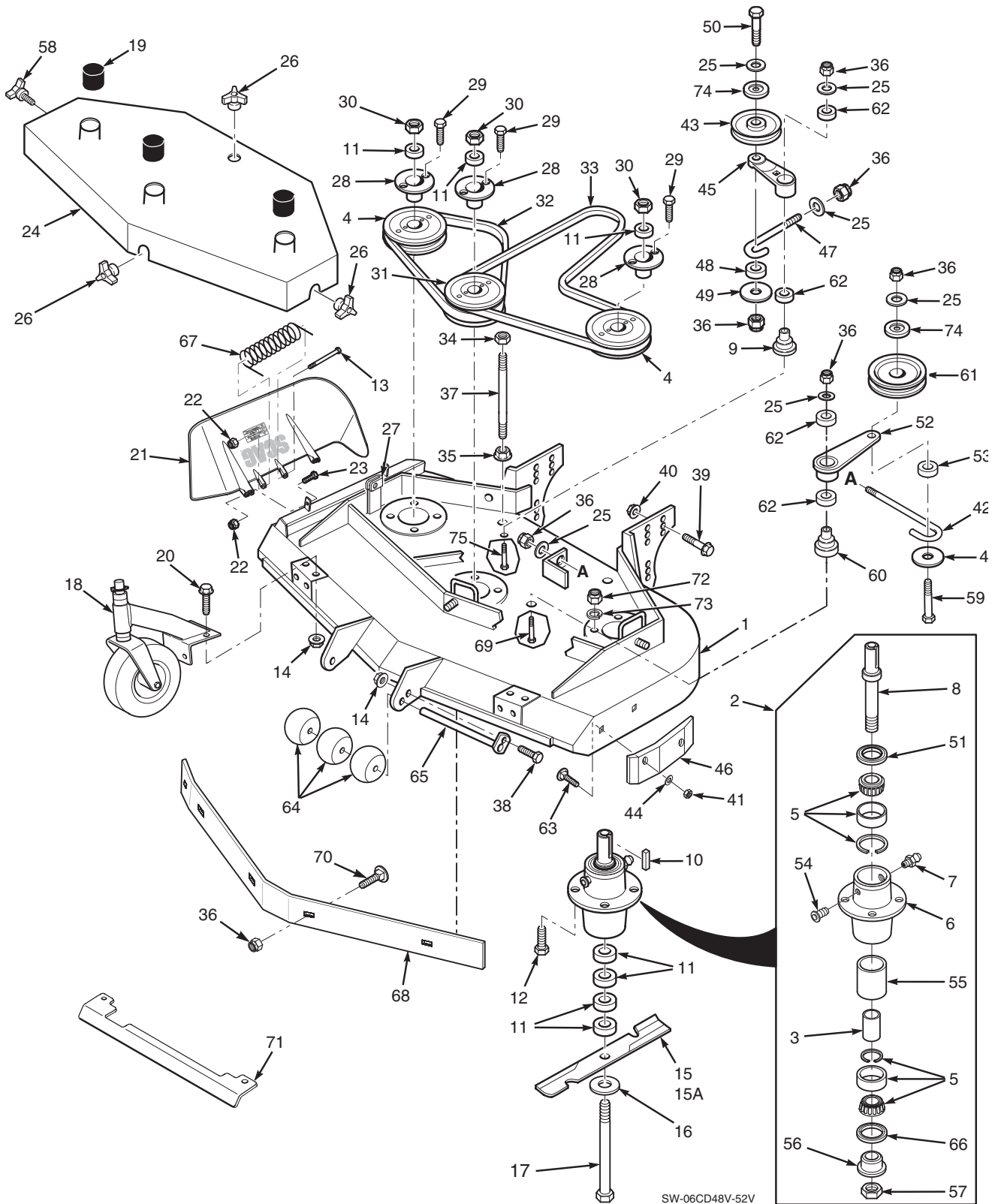

48V & 52V CUTTER DECKS

Ref. No.	Part No.	Description	48	52	Ref. No.	Part No.	Description	48	52
1	461852	Cutter Deck w/Decals	x		45	461091	Idler Arm Assy. (Incl. 62)	x	x
	461855	Cutter Deck w/Decals		x	46	483176	Pad, Deck Wear	x	x
2	461663	Spindle Assembly	x	x	47	43028	J-Rod, Idler Pulley	x	x
3	43296	Spacer, Inside	x	x	48	43077	Spacer, J-Rod	x	x
4	482744	Pulley	x	x	49	04041-12	Washer, 3/8 x 1-1/2 x 16 ga.	x	x
5	481022	Tapered Bearing	x	x	50	04001-31	Bolt, 3/8-16 x 2-1/2" Hex Head	x	x
6	43644	Spindle Housing	x	x	51	481024	Seal, Cutter Spindle	x	x
7	48114-04	Grease Fitting Str. 5/16"	x	x	52	461841	Idler Arm Assy (Includes 62)	x	x
8	43589	Spindle Shaft	x	x	53	43277	Spacer, J-Rod	x	x
9	43682	Idler Pivot	x	x	54	48677	Reief Fitting, Cutter Spindle	x	x
10	04063-08	Key, 1/4 x 1/4 x 2"	x	x	55	43312	Spacer, Outside, Cutter Spindle	x	x
11	43592	Spacer, Cutter Blade - Small	x	x	56	43297	Spindle Bushing	x	x
12	04001-175	Bolt, 5/16-18 x 1-1/2" Hex Head Gr. 8	x	x	57	481035	Nut, Cutter Spindle	x	x
13	04001-154	Bolt, 5/16-18 x 4-3/4" Hex Head	x	x	58	481625-01	Knob, w/stud	x	x
14	04019-03	Serr. Flange Nut, 5/16-18	x	x	59	04001-51	Bolt, 3/8-16 x 3-3/4" Hex Head	x	x
15	481706	Cutter Blade 16-1/2"	x		60	43681	Idler Pivot	x	x
	481707	Cutter Blade 18"		x	61	483215	Idler Pulley, Belt Clutch	x	x
15A	481710	Cutter Blade 16-1/2 Hi-Lift	x		62	48224	Bearing	x	x
	481711	Cutter Blade 18 Hi-Lift		x	63	04003-12	Bolt, Carriage 5/16-18 x 3/4"	x	x
16	04043-06	Flatwasher, 5/8" (.688 x 1.75 x .134)	x	x	64	482295	Guide Roller	x	x
17	04001-41	Hex Head Bolt, 5/8-11 x 9-1/2"	x	x	65	45944	Roller Shaft	x	x
18	461023	Caster Assembly	x	x	66	481025	Seal, Cutter Spindle	x	x
19	484368	Cap, Spindle	x	x	67	483378	Spring, Chute Return	x	x
20	04017-16	Capscrew, 5/16-18 x 3/4"	x	x	68	424839	Baffle Weldment 48V	x	
21	46	Discharge Chute 48V	x			424840	Baffle Weldment 52V		x
	46	Discharge Chute 52V		x	69	04001-62	Bolt, 3/8-16 x 3-1/4" Hex Head	x	x
22	04021-10	Nut, 5/16-18 Elastic Elastic Stop	x	x	70	04003-23	Bolt, Carriage 3/8-16 x 1"	x	x
23	04001-11	Bolt, 5/16-18 x 1-1/2" Hex Head	x	x	71	424661	Heatshield	x	x
24	462394	Belt Cover (Incl. decals)	x		72	04021-22	Nut, Hex Lock 5/16-18	x	x
	462395	Belt Cover (Incl. decals)		x	73	04030-03	Lock Washer 5/16"	x	x
25	04043-04	Flat Washer, 3/8" Special	x	x	74	424367	Dust Shield	x	x
26	04029-03	Wing Nut, 3/8-16 (Large)	x	x	75	04001-22	Bolt, 3/8-16 x 2-3/4" Hex Head	x	x
27	04110-03	U-Nut, 3/8-16	x	x					
28	48926	Tapered Hub	x	x					
29	04001-172	Bolt, 1/4-20 x 1" Hex Head Grade 8	x	x					
30	04020-09	Nut, 5/8-11 Hex	x	x					
31	482748	Pulley, Double	x	x					
32	48087	Belt, RH Blade Drive	x						
	48285	Belt, RH Blade Drive		x					
33	48089	Belt, Blade Drive	x						
	483518	Belt, Blade Drive		x					
34	04021-05	Nut, 3/8-16, Nut Centerlock	x	x					
35	04019-04	Nut, 3/8-16, Serrated Flange	x	x					
36	04021-09	Nut, 3/8-16 Elastic Stop	x	x					
37	04004-02	Bolt, 5/16-18 x 1" Hex Head	x	x					
38	04001-09	Bolt, 5/16-18 x 1" Hex Head	x	x					
39	04017-36	Cpscrw, 1/2-13 x 1" Ser. Fig. HH	x	x					
40	04112-05	Nut, 1/2-13 Spiralock	x	x					
41	04021-04	Hex Nut, 5/16-18 Center Locknut	x	x					
42	44078	J-Hook, 48V	x						
	43028	J-Hook, 52V		x					
43	48181	Idler Pulley, "V" Groove	x	x					
44	04040-04	Flatwasher, 5/16"	x	x					

NOTES

CASTER ASSEMBLY

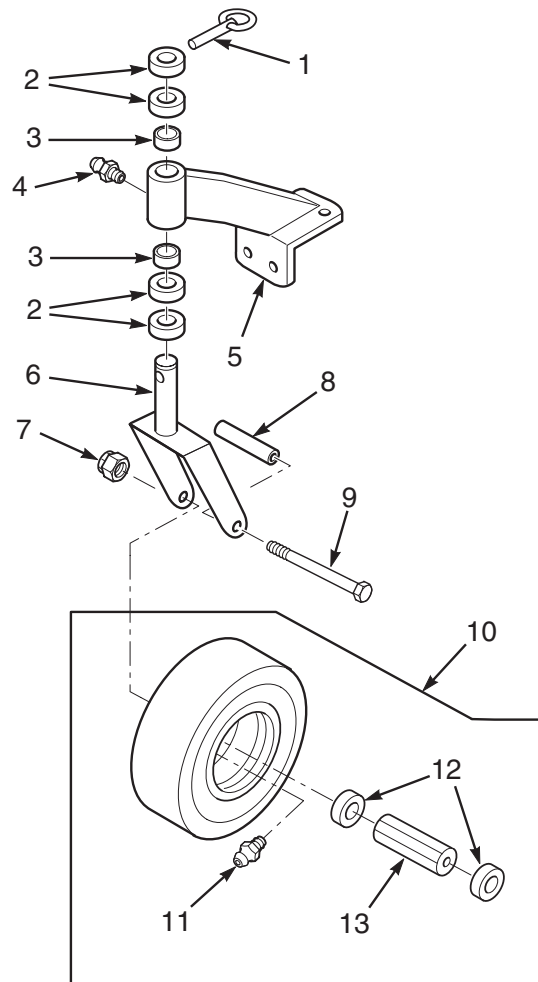

SW-SWZ2006CSTR

Ref. No.	Part No.	Description
1	04066-01	Quick Pin
2	43037-01	Spacer, Spacer Yoke, 1/2" Long
3	48100-01	Bronze Bearing
4	48114-04	Greasing Fitting
5	46082	Support Assembly (Incl. #3 & #4)
6	45006	Caster Yoke
7	04021-07	Nut, Elastic Stop 1/2-13
8	43022	Sleeve, Caster Wheel Bearing
9	04001-37	Bolt, Hex Head 1/2-13 x 5-1/2"
10	9275	Flat-Free Tire Assy. (Incl. #11, #12, #13)
11	48114-03	Grease Fitting, 45 Degree 1/4-28
12	481770	Retainer, Caster Wheel Bearing
13	481769	Roller Bearing, Caster Wheel

ENGINE DECK

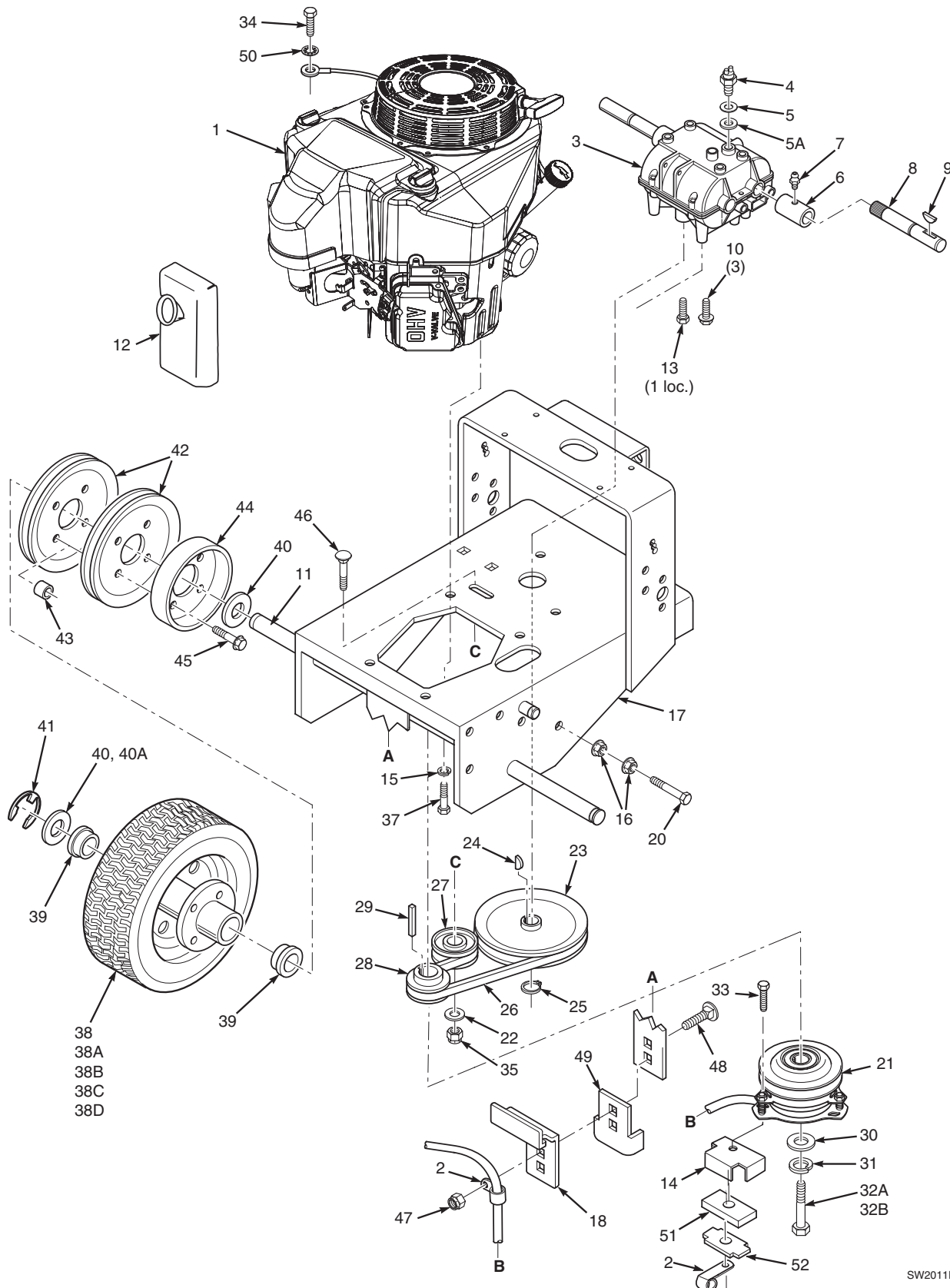

SW2011ED

ENGINE DECK

Ref. No.	Part No.	Description	Ref. No.	Part No.	Description
1	484212	Engine, Kawasaki FS481Z	29	04063-19	Key, 1/4 x 1/4 x 3/4"
	484213	Engine, Kawasaki FS541V	30	04041-28	Flat Washer, 7/16" Special
2	48030-09	Cable Clamp	31	04030-05	Lock Washer, 7/16"
3	481580	Transmission, 5-speed (Peerless 700-070, 9 tooth spline)	32A	04102-04	Bolt, 7/16-20 x 2-1/2" Hex Head
4	48231	Neutral Safety Switch	32B	04103-03	Cpsrw, M10-1.5 x55 Metric Hex Hd
5	48122-01	Fibre Washer, thin	33	04001-12	Bolt, 5/16-18 x 1-3/4" Hex Head
5A	48122-02	Fibre Washer, thick	34	04002-06	Bolt, M8-1.25 x 16
6	481581	Coupler, Jackshaft	35	04021-09	Nut, 3/8-16 Elastic Stop
7	48114-05	Grease Fitting, straight 1/4-28	36	04040-15	Flat Washer, 5/16"
8	481582	Jackshaft (fits SW32,36,48& 52)	37	040001-32	Bolt, Hex Head 3/8-16 x 1-1/4"
9	04063-09	Key, Hi-Pro #9	38	48192	Wheel Assembly (incl. 38A-38B) (fits SW36,48,52)
10	04017-16	Bolt, 5/16-18 X 3/4" Hex Head		48253	Wheel Assembly (Incl. 38C - 38D) (SW32)
11	43085**	Wheel Axle (SW36,48 & 52)	38A	481860	Tire, 13 x 6.50-6, 2-ply (fits SW36,48,52)
	43104**	Wheel Axle (SW 32)	38B	481859	Rim & Bearing Assembly (incl. 39)
12		Muffler (Contact Engine Mfg.)	38C	481861	Tire, 13 x 5.00-6 2-ply (SW32 only)
13	04001-08	Bolt, 5/16-18 X 3/4" Hex Head	38D	481862	Rim Assembly (incl. 39) (SW32 only)
14	422533	Backing Plate	39	481858	Wheel Bearing
15	04030-04	Lock Wshr. 3/8"	40	04042-05	Washer, 1-1/16 x 1-3/4 x 12 ga
16	04019-04	Nut, 3/8-16 Serrated Flange	40A	04041-14	Washer, 1-1/16 x 1-1/2 x 18 ga
17	462285	Engine Deck (fits SW32)	41	04050-08	Retaining Ring, 1" Ext.- "E"
	462286	Engine Deck (fits SW36,48 & 52)	42	48200	Pulley, Wheel Drive
18	424620	Plate, Clutch Bracket	43	43088	Spacer, Wheel Pulley
19	04019-03	Nut, 5/16-18 Serrated Flange	44	48209	Brake Drum
20	04001-51	Bolt, 3/8-16 x 3-3/4" Hex Head	45	04017-19	Bolt, 5/16-18 x 1-1/2" Serrated Flange
21	461397	Electric Clutch (Ogura)	46	04003-03	Bolt, 3/8-16 x 2" Carriage
22	04041-07	Washer, 3/8" (.391 x .938 x .105)	47	04021-10	Nut, 5/16-18 Elastic Stop
23	48197	Pulley, Transmission Input	48	04003-04	Bolt, 5/16-18 x 1" Carriage
24	04063-07	Key, Woodruff #9	49	421370	Anti Rotation Bracket
25	04050-09	Retaining Ring, 5/8" Ext, Basic	50	04031-03	Lock Washer External Tooth
26	48203	Belt, Transmission Drive	51	481716	Rubber Pad, Clutch Stop
27	483208	Idler Pulley, Transmission	52	422534	Plate, Backing
28	481666	Pulley, Traction Drive			

** = Requires welding onto chassis.

HANDLE ASSEMBLY

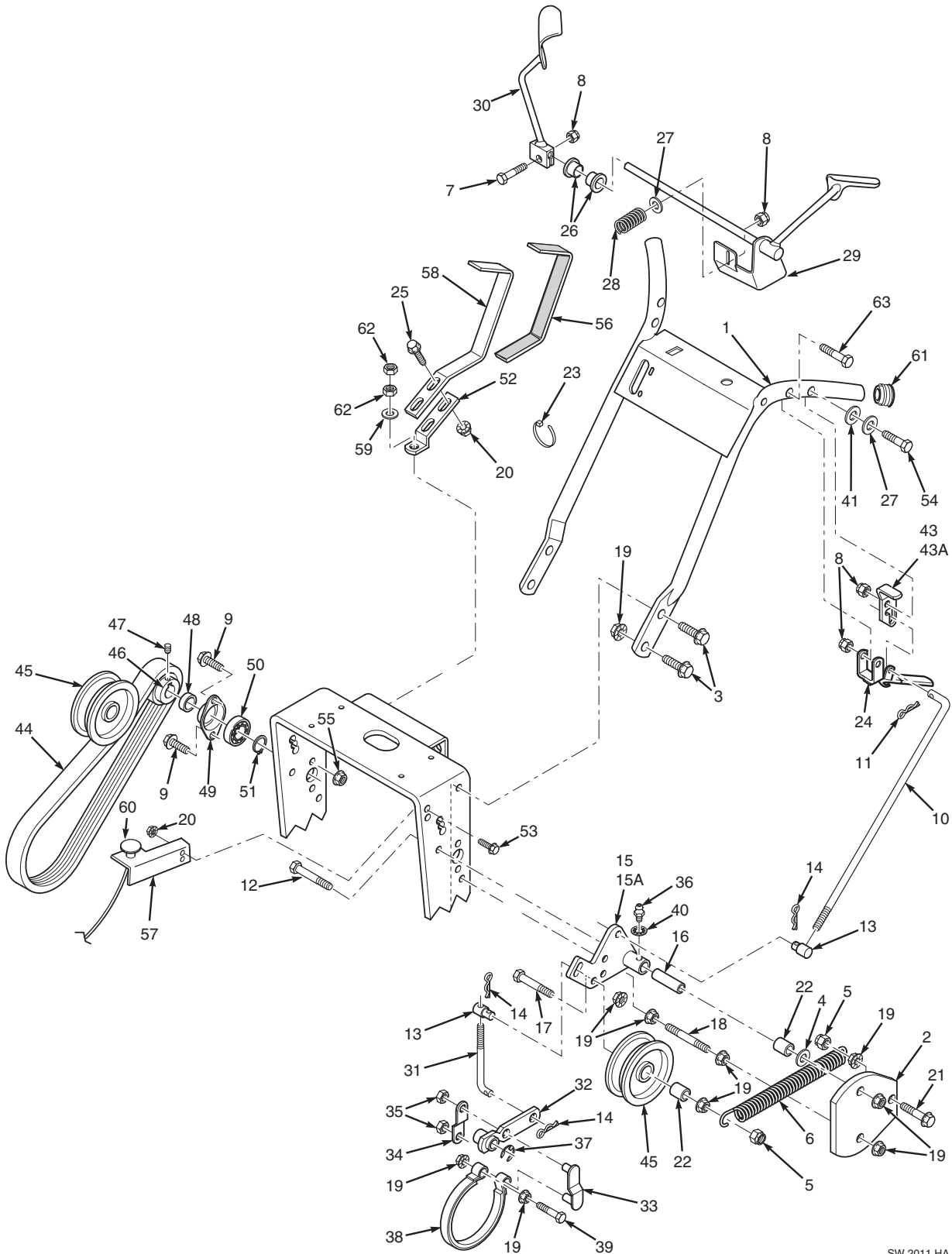

SW 2011 HA

HANDLE ASSEMBLY

Ref. No.	Part No.	Description
1	461972	Handle Assembly
2	421360	Belt Guard
3	04017-27	Capscrew, 3/8-16 x 1" Serr. Flg.
4	04041-07	Washer, 3/8" (.391 x .938 x .105)
5	04021-09	Nut, 3/8-16 Elastic Stop
6	48755	Spring, Idler
7	04001-10	Bolt, 5/16-18 x 1-1/4" Hex Head
8	04021-10	Nut, 5/16-18 Elastic Stop
9	04017-05	Capscrew, 1/4-20 x 3/4" Hex Head
10	44140	Control Rod, Steering
11	04062-02	Hair Pin, Small
12	04001-23	Bolt, 3/8-16 x 4-1/2" Hex Head
13	43032	Swivel Joint
14	04062-01	Hair Pin, Large .094 Dia.
15	45847	Idler Bracket, RH
15A	45846	Idler Bracket, LH
16	43092	Idler Sleeve
17	04001-62	Bolt, 3/8-16 x 3/4" Hex Head
18	04004-17	Stud, 3/8-16 x 5"
19	04019-04	Nut, 3/8-16 Serrated Flange
20	04019-03	Nut, 5/16-18 Serrated Flange
21	04017-28	Cpscrew, 3/16-18 x 1-1/4" Serr. Flg
22	43286	Spacer
23	48028-05	Cable Tie
24	483160	Steering Lever
25	04017-17	Capscrew, 5/16-18 x 1" Serr. Flg.
26	483142	Bushing
27	04040-15	Washer, 5/16 (.375 x .875 x .083)
28	483040	Spring, Operator Presence
29	451915	Operator Presence Lever, LH
30	451917	Operator Presence Lever, RH
31	44005	Brake Rod
32	45092	Brake Lever
33	45093	Brake Link
34	42254	Brake Link Plate
35	04024-01	Nut, 3/8 Push-on
36	48114-05	Grease Fitting, Straight 1/4-28
37	04050-01	Retaining Ring, 5/8 Ext. "E"
38	48210	Brake Band
39	04001-45	Bolt, 3/8-16 x 2" Hex Head
40	04031-08	1/4" Internal Tooth Lockwasher
41	04032-01	Socket Head Capscrew #8-32 x 1/2"
42	04015-13	Socket Head Capscrew #8-32 x 1/2"
43	461242	Neutral Latch, RH
43A	461241	Neutral Latch, LH
44	48202A	Belt, Wheel Drive
45	483211	Idler Pulley, Wheel Drive

Ref. No.	Part No.	Description
46	482645	Pulley, Jackshaft (Inc. 47)
47	04012-04	Setscrew, Hex Socket Knurl Cup Pt. 5/16-18
48	43098	Spacer, Jackshaft Pulley
49	48223	Flange, Jackshaft Bearing
50	48224	Bearing, Jackshaft
51	04050-09	Retaining Ring, 5/8 Ext. Basic
52	422279	Shift Lever
53	04017-16	Capscrew, 5/16-18 x 3/4" Serr. Flg.
54	04001-17	Bolt, 5/16-18 x 2" Hex Head
55	04019-02	Nut, 1/4-20 Serrated Flange
56	481839	Grip, Shift Handle
57	424113	Bracket, Choke Mounting
58	461163	Shift Lever Extention (incl. 56)
59	04041-07	Washer, 3/8 (.391x .938 x .105)
60	482314	Choke Control
61	483161	Plug, Handlebar
62	04020-14	Nut, 3/8-24 UNF
63	04001-53	Bolt, 5/16-18 x 2-1/2"
64	482547	Fuel Tank Cap

SW FUEL SYSTEM

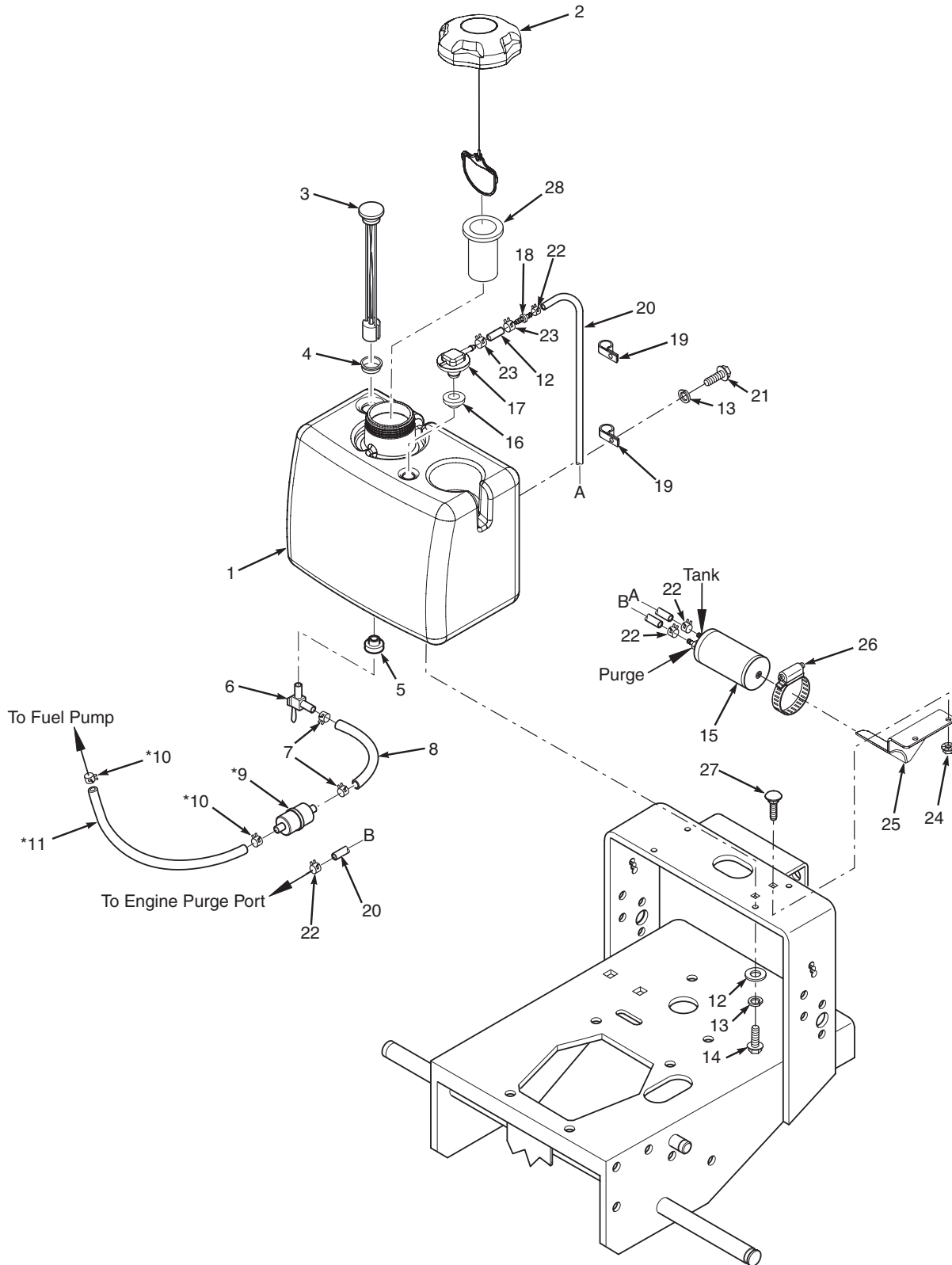

2011 SW EPA Phase 3 Fuel System

SW FUEL SYSTEM

Ref. No.	Part No.	Description
1	462290	Fuel Tank Assembly (incl. #3, 4, 5, 6, 16, 17)
2	484286	Fuel Cap w/ Tether (E.P.A.)
3	484259	Fuel Gauge Assembly (incl. #4)
4	484242	Seal, Fuel Gauge
5	482571	Bushing, .56 Dia. Viton
6	483747	Ball Valve w/Screen
7	48059-01	Clamp, Fuel Hose
8	483617	Fuel Hose, 1/4" ID (order by inch)
9	*	Fuel Filter
10	*	Clamp, Fuel Hose
11	*	Fuel Hose
12	484347	Hose, Vapor Recovery 1/4" (order by inch)
13	04030-03	Lockwasher, 5/16" Spring
14	04001-09	Bolt, Hex Head 5/16-18 x 1"
15	484287	Carbon Canister
16	484285	Grommet, Viton,
17	484333	Fitting, Remote Vent
18	484343-01	Mender, 1/4 x 3/16 w/.02 Hole
19	48030-22	Clamp, 3/8"
20	484345	Hose, Vapor Recovery 3/16" (order by inch)
21	04001-08	Bolt, Hex Head 5/16-18 x 3/4"
22	48059-05	Clamp, Vapor Recovery Hose 3/16"
23	48059-02	Clamp, Fuel Hose 7/32" ID
24	04019-03	Nut, Serrated Flange 5/16-18
25	452176	Bracket, Canister Mounting
26	48136-17	Clamp
27	04003-04	Bolt, Carriage 5/16-18 X 1"
28	484279-01	Tube, Fuel Tank Insert - 4"

* = Available through engine manufacturer only.

INSTRUMENT PANEL

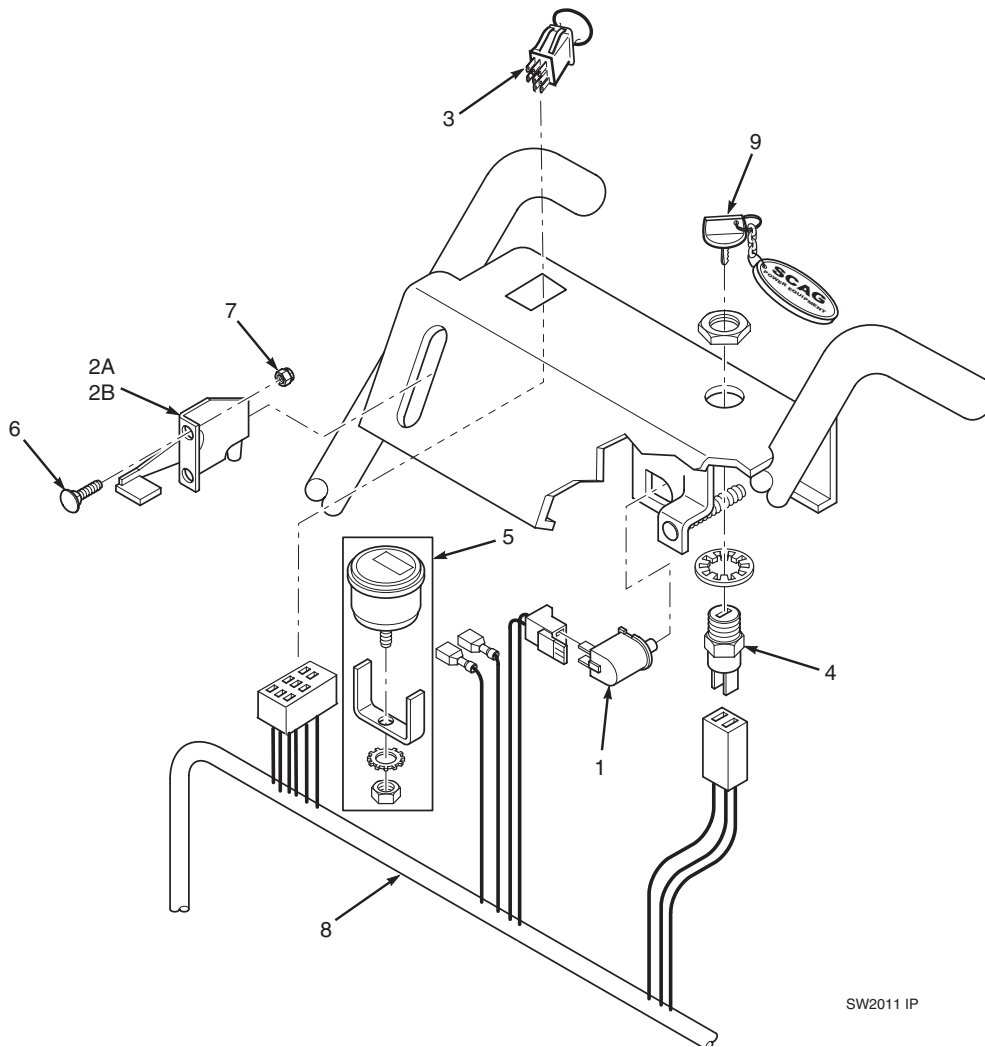

SW2011 IP

Ref. No.	Part No.	Description
1	48717	Switch, Neutral Lock
2A	482814	Throttle Control - Kohler
2B	48946	Throttle Control - Kawasaki
3	483957	Engagement Switch, Electric Clutch
4	48609	Key Switch
5	48023	Hour Meter (dealer installed)
6	04003-43	Bolt, Carriage #10-32 x 1/2"
7	04021-26	Nut, #10-32 Elastic Stop
8	482711	Handle Wire Harness, Manual Start
9	462069	Key Chain w/Keys
	483609	Key w/Shroud
NS	48030-09	Clamp, Wire Harness

PEERLESS TRANSMISSION 700-070

FOR REFERENCE ONLY - ORDER PARTS FROM PEERLESS / TECUMSEH

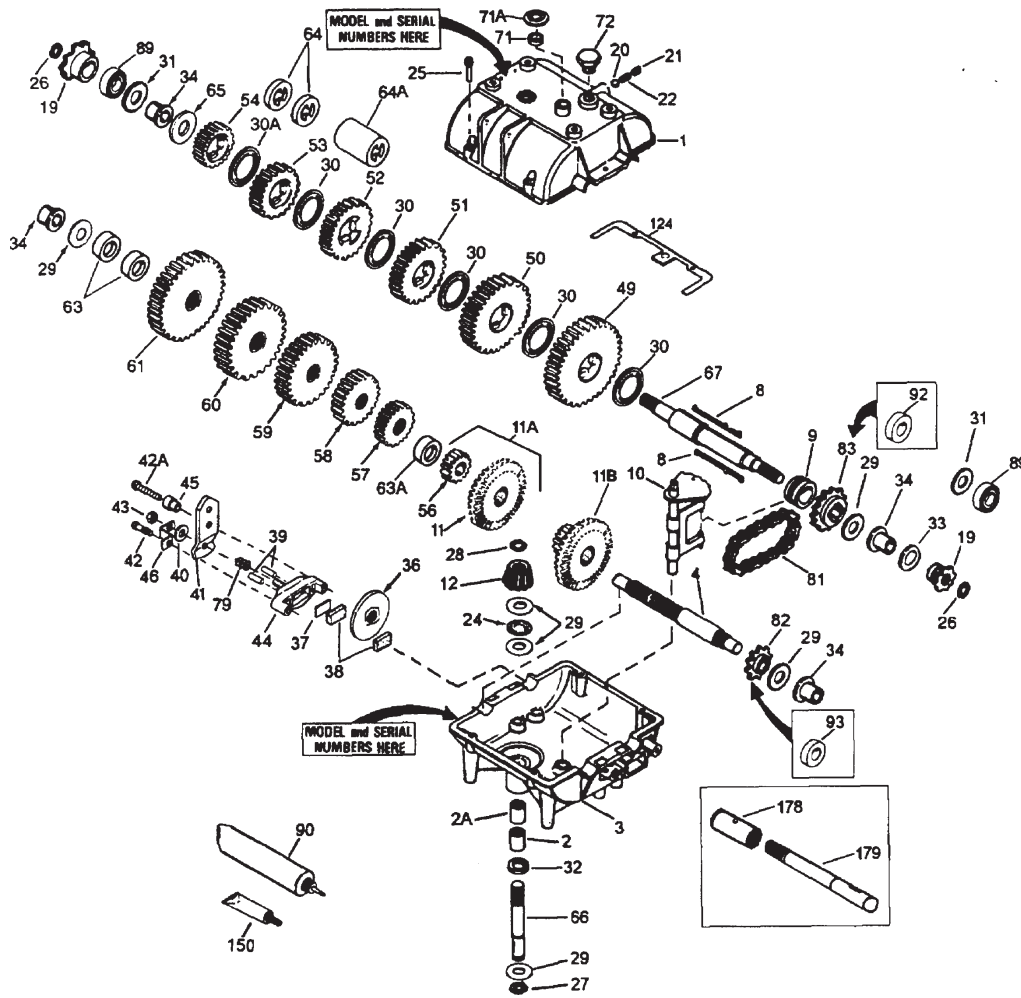

Ref. No.	Part No.	Description	REF. NO.	PART DESCRIPTION
1	772083A	Case, Transmisson	50	778125 Spur Rear (35 teeth)
2	780086A	Needle Bearing Grease Spec	51	778239A Spur Gear (32 teeth-steel)
2A	780142	Needle Bearing	52	778124A Spur Gear (30 teeth)
3	770061A	Case, Transmission	53	778123A Spur Gear (25 teeth)
8	792089A	Shift Key	56	778145 Spur Gear (12 teeth-steel)
9	784266	Shift Collar	57	778151 Spur Gear (15 teeth)
10	784376	Shift Rod & Fork	58	778240 Spur Gear (18 teeth-steel)
11	778154	Bevel Gear (42 teeth)	59	778126A Spur Gear (20 teeth)
12	778176	Bevel Pinion (14 teeth-steel)	60	778127A Spur Gear (25 teeth)
20	792077	Steel Ball, 5/16" dia.	65	780139 Washer
21	792078	Set Screw, 3/8-16 x 3/8"	66	776135 Input Shaft (3-11/16" long)
22	792079	Spring	67	776402 Shifter & Brake Shaft
24	780071	Thrust Bearing	71	788069 Square Cut Ring
25	792073	Screw, 1/4-20 x 1-1/4" (6)	72	792074 Threaded Plug (Shipping only, not used)
27	792035	Retaining Ring	81	786081 Roller Chain (No. 41 chain, 24 links)
28	788040	Retaining Ring	82	786082 Sprocket (9 teeth)
29	780072	Washer (6)	83	786083 Sprocket (18 teeth)
30	780108	Washer (5)	90	788067B Grease (32 oz. bottle Bentonite grease)
32	792001	"O" Ring	150	510334 Gasket Eliminator (Loctite #515)
34	780105A	Flanged Bushing	178	* Coupling (See page 26-27 for part number)
49	778146A	Spur Gear (37 teeth)	179	* Connector Shaft (See page 26-27 for part number)

WIRE HARNESSES

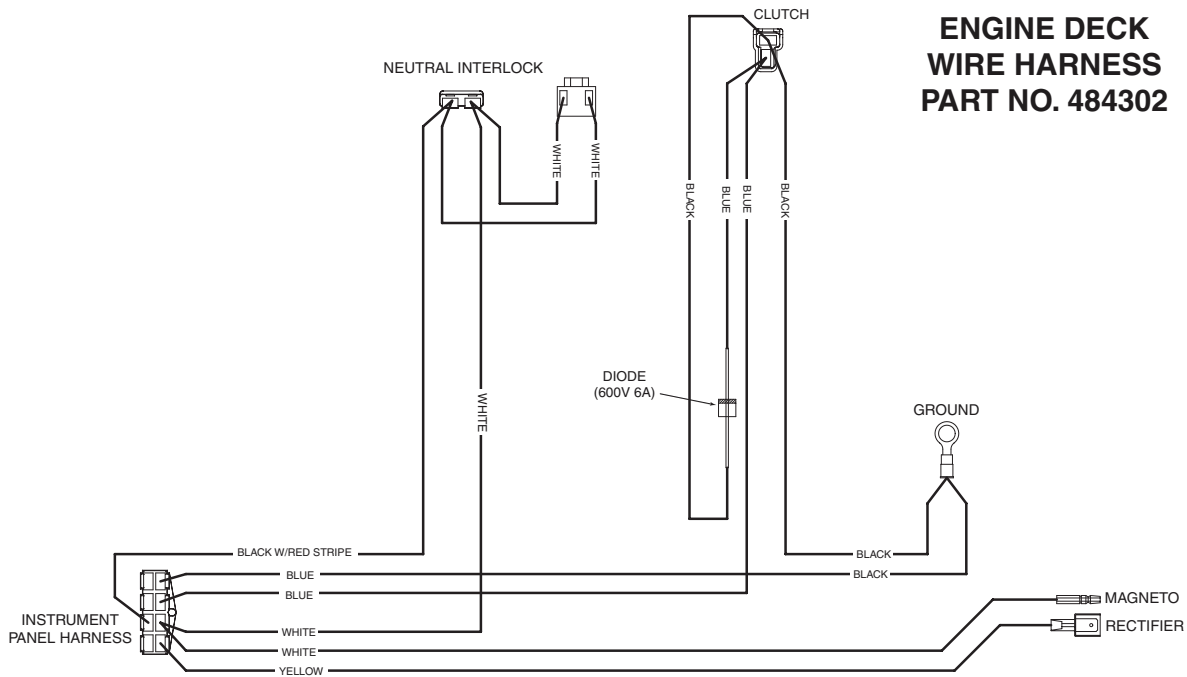

HANDLE WIRE HARNESS PART NO. 482711

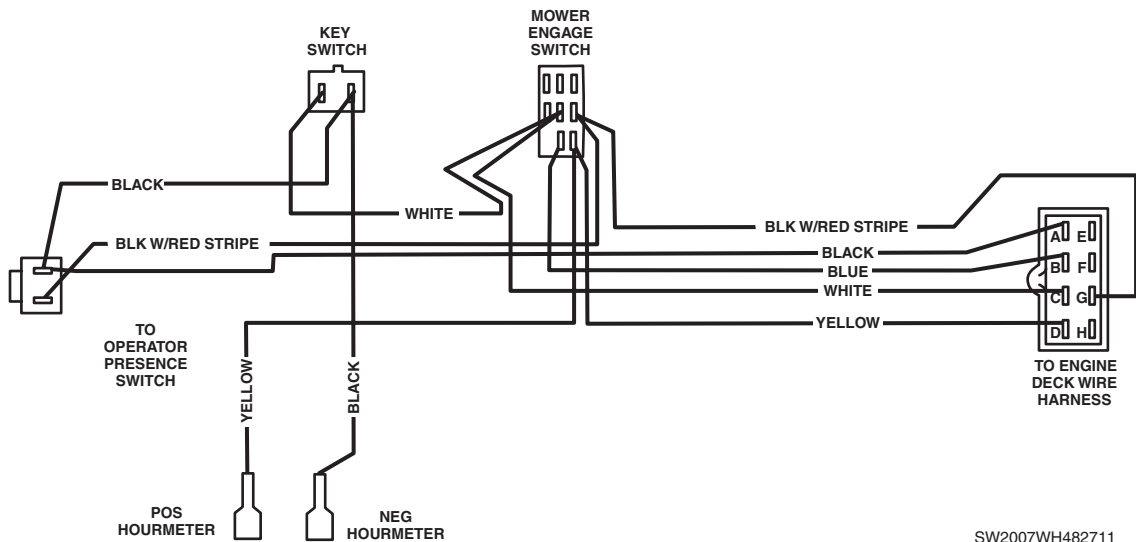

SW2007WH482711

NOTES

REPLACEMENT DECALS AND INFORMATION PLATES



1



2

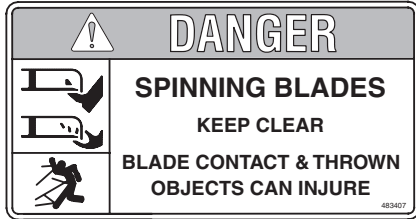

3

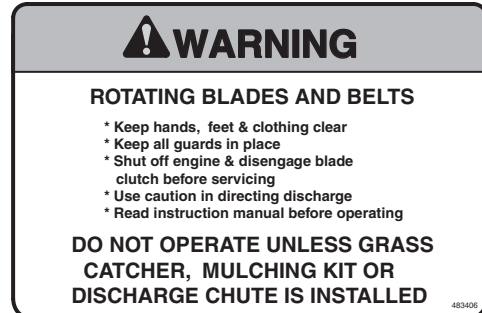

4

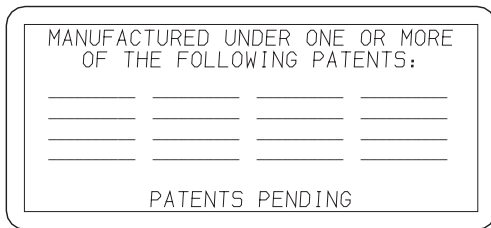

5

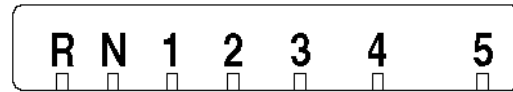

6

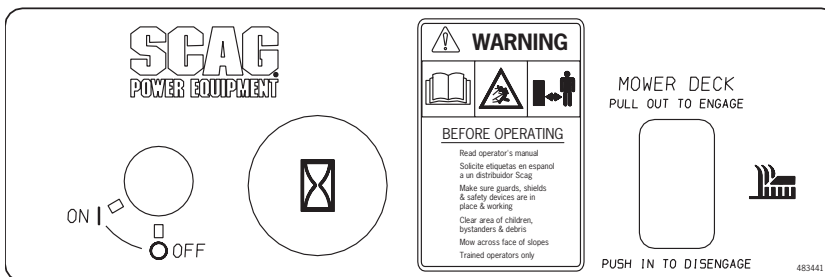

7



8



9



10

REPLACEMENT DECALS AND INFORMATION PLATES

Ref. No.	Part No.	Description
1	483405	Decal, Discharge Chute
2	48314	Decal, Scag Logo
3	483407	Decal, Danger-Spinning Blades
4	483406	Decal, Warning-Rotating Blades
5	483044	Decal, Patents
6	48332	Decal, Shift Index
7	483441	Decal, Instrument Panel - Rear
8	48404	Decal, Metalcraft - Made in USA
9	483404	Decal, Sulky Attachment
10	483402	Decal, Belt Cover
11	481483	Decal, Instrument Panel - Front
12	482816	Decal, Height of Cut
13	48315	Decal, 32
	482297	Decal, 36 Advantage
14	483199	Decal, 48 Velocity Plus
	483200	Decal, 52 Velocity Plus
15	481971	Decal, Heavy Duty Commercial
**	461986	Spanish Decal Kit, Walk-Behinds (Not Shown)
**	483900	Decal, Warning Spark Arrest (Not Shown) - LE Models Only
**	484339	Decal, '10 C.A.R.B. Emissions (Not Shown) - LE Models Only

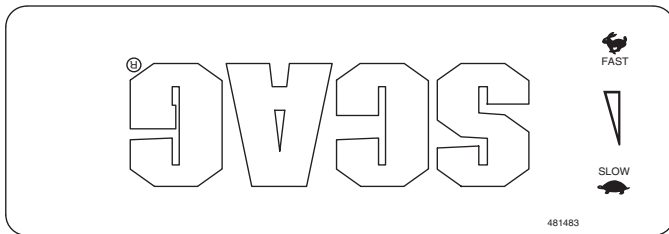

11

482816 **CUTTING HEIGHT ADJUSTMENT**

DECK MOUNTING HOLE POSITION
NUMBER OF CASTER SPACERS (BELOW SUPPORT)

	NUMBER OF SPACERS ABOVE CUTTER BLADES						
	0	1	2	3	4	5	
TOP	0	-	-	2-3/8	2-1/8	1-7/8	1-5/8
MIDDLE	0	-	-	2-5/8	2-3/8	2-1/8	1-7/8
MIDDLE	1	-	-	2-3/4	2-1/2	2-1/4	2
BOTTOM	2	-	-	-	-	2-7/8	2-5/8
BOTTOM	3	-	4	3-3/4	3-1/2	3-1/4	3
BOTTOM	4	4-3/8	4-1/8	3-7/8	3-5/8	3-3/8	3-1/8

12



13



14



15

LIMITED WARRANTY - COMMERCIAL EQUIPMENT

Any part of the Scag commercial mower manufactured by Scag Power Equipment and found, in the reasonable judgment of Scag, to be defective in materials or workmanship, will be repaired or replaced by an Authorized Scag Service Dealer without charge for parts and labor during the periods specified below. This warranty is limited to the original purchaser provided the product was purchased from an Authorized Scag Power Equipment Dealer and is not transferable. Proof of purchase will be required by the dealer to substantiate any warranty claims. All warranty work must be performed by an Authorized Scag Service Dealer.

This warranty is limited to the following specified periods from the date of the original retail purchase for defects in materials or workmanship:

- Wear items including drive belts, blades, hydraulic hoses and tires are warranted for ninety (90) days.
- Batteries are covered for ninety (90) days.
- Frame and structural components including oil reservoir and oil coolers are warranted for two (2) years (parts and labor) for commercial use or three (3) years / 500 hours (whichever comes first) (parts and labor) for non-commercial use.
- Cutter decks are warranted against cracking for a period of three (3) years. (parts and labor 1st and 2nd year; parts only 3rd year.) The repair or replacement of the cutter deck will be at the option of Scag Power Equipment. We reserve the right to request components for evaluation. This warranty does not cover any mower that has been subject to misuse, neglect, negligence, or accident, or that has been operated in any way contrary to the operating instructions as specified in the Operator's Manual.
- Engines and electric starters are covered by the engine manufacturer's warranty period.
- Major drive system components are warranted for two (2) years (parts and labor) for commercial use or three (3) year / 500 hour (whichever comes first) (parts and labor) for non-commercial use by Scag Power Equipment. (commercial and non-commercial warranty excludes fittings, hoses, drive belts). The repair or replacement of the hydraulic pump or hydraulic motor will be at the option of Scag Power Equipment. This warranty does not cover any mower that has been subject to misuse, neglect, negligence, or accident, or that has been operated in any way contrary to the operating instructions as specified in the Operator's Manual.
- Electric clutches have a Limited Warranty for two (2) years (parts and labor) for commercial use or three (3) year / 500 hours (whichever comes first) (parts and labor) for non-commercial use.
- Spindle assemblies have a Limited Warranty for three years (parts and labor 1st year and 2nd; parts only 3rd year).
- Any Scag product used for rental purposes is covered by a 90 day warranty.

The Scag mower, including any defective part must be returned to an Authorized Scag Service Dealer within the warranty period. The expense of delivering the mower to the dealer for warranty work and the expense of returning it to the owner after repair will be paid for by the owner. Scag's responsibility is limited to making the required repairs and no claim of breach of warranty shall be cause for cancellation or rescission of the contract of sale of any Scag mower. "Non-Commercial" use is defined as a single property owner, where the single property is the residence of the owner of the mower. If the mower is cutting more than the owners single property, it is deemed commercial use and the "non-commercial" warranty does not apply. Scag Power Equipment reserves the right to deny and / or void the non-commercial warranty if it believes it to be in commercial use.

This warranty does not cover any mower that has been subject to misuse, neglect, negligence, or accident, or that has been operated in any way contrary to the operating instructions as specified in the Operator's Manual. The warranty does not apply to any damage to the mower that is the result of improper maintenance, or to any mower or parts that have not been assembled or installed as specified in the Operator's Manual and Assembly Manual. The warranty does not cover any mower that has been altered or modified, changing performance or durability. In addition, the warranty does not extend to repairs made necessary by normal wear, or by the use of parts or accessories which, in the reasonable judgment of Scag, are either incompatible with the Scag mower or adversely affect its operation, performance or durability.

Scag Power Equipment reserves the right to change or improve the design of any mower without assuming any obligation to modify any mower previously manufactured. All other implied warranties are limited in duration to the two (2) year for commercial use, three (3) years / 500 hour for non-commercial use or ninety (90) days for mowers used for rental purpose. Accordingly, any such implied warranties including merchantability, fitness for a particular purpose, or otherwise, are disclaimed in their entirety after the expiration of the appropriate two year or ninety day warranty period. Scag's obligation under this warranty is strictly and exclusively limited to the repair or replacement of defective parts and Scag does not assume or authorize anyone to assume for them any other obligation. Some states do not allow limitations on how long an implied warranty lasts, so the above limitation may not apply to you.

Scag assumes no responsibility for incidental, consequential or other damages including, but not limited to, expense for gasoline, expense of delivering the mower to an Authorized Scag Service Dealer and expense of returning it to the owner, mechanic's travel time, telephone or telegram charges, rental of a like product during the time warranty repairs are being performed, travel, loss or damage to personal property, loss of revenue, loss of use of the mower, loss of time or inconvenience. Some states do not allow the exclusion or limitation of incidental or consequential damages, so the above limitation or exclusion may not apply to you. This warranty gives you specific legal rights, and you may also have other rights which vary from state to state.

