

YANMAR

OPERATOR'S MANUAL

COMPACT TRACTOR

Sx Series

Sx3100

Version 1.0

Code No.:0A041-U00901

ENGLISH

Yanmar America Corporation
101 International Pkwy
Adairsville, GA 30103

PRINTED IN U.S.A.

CALIFORNIA
Proposition 65 Warning

Diesel engine exhaust and some of its constituents are known to the State of California to cause cancer, birth defects, and other reproductive harm.

CALIFORNIA
Proposition 65 Warning

Battery posts, terminals and related accessories contain lead and lead compounds, chemicals known to the State of California to cause cancer and birth defects or other reproductive harm. Wash hands, after handling.

IMPORTANT
Pursuant to California Public Resources Code Section 4442.6
WARNING - Operation of This Equipment May Create Sparks That Can Start Fires Around Dry Vegetation. A Spark Arrestor May be Required. The Operator Should Contact Local Fire Agencies For Laws or Regulations Relating to Fire Prevention Requirements.

1A8250-65390

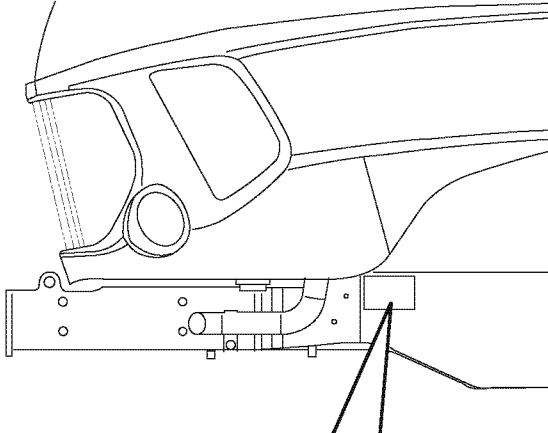

IMPORTANT

Pursuant to California Public Resources Code Section 4442.6
WARNING - Operation of This Equipment May Create Sparks That Can Start Fires Around Dry Vegetation. A Spark Arrestor May be Required. The Operator Should Contact Local Fire Agencies For Laws or Regulations Relating to Fire Prevention Requirements.

1A8250-65390

Operator's Record

Owner's Name	
Owner's Address	
Owner's Phone Number	
Dealer/Seller Name	
Dealer/Seller Address	
Dealer/Seller Phone Number	

INTRODUCTION

Welcome to the World of Yanmar Tractor

Thank you for purchasing Yanmar tractor product that has been designed and manufactured based on the Yanmar state-of-the-art technology and rich expertise in developing and manufacturing products.

Handle the tractor correctly by following the instructions in the *Operator's Manual* so that the tractor will provide long years of reliable and predictable service.

The *Operator's Manual* constitutes an indispensable part of the Yanmar tractor product. Always keep the *Operator's Manual* readily accessible.

Carefully study the *Operator's Manual* to get familiar with the instructions and informations contained in the *Operator's Manual*. The instructions and informations are helpful in using the tractor correctly and safely, avoiding personal injury and other accidents during operation and servicing of the tractor. When using any implement together with the tractor, also carefully study the *Operator's Manual* of the implement so that the operator can use the implement safely, correctly and efficiently.

The *Operator's Manual* is organized with sections arranged in a particular order so that the operator can better understand the safety messages and the controls on the tractor to help the operator operate the tractor correctly and safely. The *Operator's Manual* will also help the operator answer questions about operation and servicing.

The tractor shown in the *Operator's Manual* may somewhat differ from the actual tractor. The *Operator's Manual* will still assist the operator in understanding the instructions associated with the tractor. Before delivery of the tractor, your Yanmar Tractor dealer has performed a pre-delivery check to ensure that the tractor can long remain problem free.

All information, descriptions, specifications, drawings, illustrations, and pictures in this manual are based on the latest information available at the time this manual was published. Yanmar reserves the right to make changes at any time without prior notice.

© 2011 Yanmar Co., Ltd.

Yanmar licenses the usage rights of this manual in North America to YANMAR AMERICA CORPORATION.

© 2011

PICTOGRAPHS

To help assist the operator in operating the tractor, various easy-to-understand pictographs have been developed and are used throughout this manual. The pictographs are listed below together with the corresponding meanings.



Safety alert symbol

<Instrument panel>



Fuel level



4-Wheel drive



Revolutions Per Minute (rpm)



Engine coolant temperature



Alternator/Battery charging condition



Parking brake



Engine oil pressure



Power Take Off (PTO)



Glow

<Lights>



Turn signal



Headlight and sidelight



Headlight, sidelight and rear worklight



Hazard warning lights



All lights are turned OFF

<Starter key switch>



Engine start



Engine run



Engine shut-off

<Levers and knobs>



Power Take Off (PTO) OFF position



Power Take Off (PTO) ON position



Mid-Power Take Off (PTO) position



Mid-/Rear Power Take Off (PTO) position



Rear Power Take Off (PTO) position



Parking brake lock lever



Cruise control lever



Slow



Fast



Position control raised position



Position control lowered position



Implement lock position

TABLE OF CONTENTS

1. SAFETY PRECAUTIONS	1-1
1. About The Operator's Manual	1-1
2. Safety Alert Symbol.....	1-2
3. Precautions Before Operating The Tractor	1-3
4. Safe Practices for Operating the Tractor.....	1-4
1. Start the Tractor.....	1-4
2. Work with the Tractor	1-5
3. Stop the Tractor.....	1-5
4. Considerations for Safety of a Child.....	1-5
5. Operate the Tractor on Slopes.....	1-6
6. Travel on a Road.....	1-7
7. Safe Practices for Parking the Tractor	1-7
8. Operate the Power Take Off (PTO).....	1-8
9. Use the 3-Point Hitch	1-8
10. Roll-Over Protective Structure (ROPS) Precautions	1-8
11. Safe Practices for Servicing the Tractor.....	1-9
12. Replace the Rubber Product/s, such as Hydraulic Hose, Fuel Hoses, Power Steering Hoses, Radiator Hoses and Air Intake Hose for Every 2 Years	1-10
13. Understand the Tractor Safety Decals	1-11
■ Safety Alert Symbol.....	1-11
■ Care of DANGER, WARNING and CAUTION Decals.....	1-11
2. SERVICE THE TRACTOR	2-1
3. SPECIFICATIONS	3-1
1. Specifications Table	3-1
2. Traveling Speeds	3-2
4. IMPLEMENT CAPACITIES	4-1
5. NAMES AND FUNCTIONS OF COMPONENTS	5-1
1. Overview	5-1
■ Names of Main Components.....	5-1
■ Functions of Main Components.....	5-2
2. Operator Station Controls.....	5-3
■ Names of Components.....	5-3
■ Function of Components	5-4
3. Instrument Panel	5-12
6. PRE-OPERATION CHECK	6-1
1. Pre-Operation Check.....	6-1
2. Precautions Before Operation.....	6-1
3. Routine Checks	6-1
4. Prevent Damage to Plastic Surfaces and Painted Surfaces	6-1

TABLE OF CONTENTS

7. OPERATE THE ENGINE	7-1
1. Start the Engine.....	7-1
2. Start the Engine in Cold Weather.....	7-7
3. Shut Off the Engine.....	7-7
4. Restart a Stalled Engine.....	7-8
5. Start When the Engine Runs Out of Fuel.....	7-9
8. OPERATE THE TRACTOR	8-1
1. Operate a New Tractor.....	8-2
■ Always run the tractor at less than full speed during the first 50 hours of operation	8-2
■ Change the lubricating oil for the new tractor.....	8-2
2. Raise and Lower the Roll-Over Protective Structure (ROPS).....	8-3
■ Lower (folded "down") the Roll-Over Protective Structure (ROPS).....	8-3
■ Raise (unfolded "up") the Roll-Over Protective Structure (ROPS).....	8-4
3. Operate the Tractor.....	8-5
■ Turn Signals.....	8-5
■ Light Control/Hazard Lights Button Switch.....	8-6
■ Warm Up Transmission Hydraulic Oil in a Cold Weather Situation.....	8-6
■ Range Gear Lever.....	8-7
■ 2WD/4WD Lever.....	8-7
■ Tips on the 4-Wheel Drive.....	8-8
■ 3-Point Hitch Control Lever.....	8-8
■ Throttle Control Lever.....	8-9
■ Drive Pedals.....	8-9
■ Engage the Cruise Control.....	8-10
■ Disengage the Cruise Control.....	8-10
4. Stop the Tractor.....	8-11
■ Stopping Procedure.....	8-11
■ Stop in an Emergency.....	8-12
5. Use the Brake.....	8-13
■ Engage the Parking Brake.....	8-13
■ Disengage the Parking Brake.....	8-13
■ Use the Brake Pedals as Driving Brake (On Roads).....	8-13
■ Use the Brake Pedals for Easier Turning.....	8-14
6. Practices for Safe Operation.....	8-14
■ Differential Lock.....	8-14
■ Drive the Tractor on Roads.....	8-15
■ Push or Tow the Tractor.....	8-16
■ Allowable Loads When Towing with the Tractor.....	8-16
■ Transport the Tractor on a Trailer.....	8-17
■ Operate on Slopes and Rough Terrain.....	8-18
■ Uphill and Downhill Slopes.....	8-19
■ Steep Downhill Slope.....	8-19
■ About the Power Steering.....	8-19

9. POWER TAKE OFF (PTO) SYSTEM..... 9-1

- 1. Operate the Power Take Off (PTO) System..... 9-1
 - Determine the Appropriate Power Take Off (PTO) Speed 9-2
 - Engage Power Take Off (PTO) (with the operator on the operator seat) 9-3
 - Engage the Rear Power Take Off (PTO) (with the operator out of the operator seat) 9-3
 - Disengage Power Take Off (PTO) (with the operator on the operator seat) 9-4
- 2. Use the Power Take Off (PTO) Safely 9-4
 - Use the Power Take Off (PTO) Shaft Cap 9-4
- 3. Install an Implement to the Power Take Off (PTO) Driveline 9-5

10.3-POINT HITCH AND DRAWBAR..... 10-1

- 1. 3-Point Hitch..... 10-1
 - Use the 3-Point Hitch Control Lever 10-2
 - Use the Position Stop Knob 10-2
 - Hydraulic Flow Control/Stop Knob 10-2
 - Use the Lower Links (and Top Link as Needed) 10-3
 - Level the Implement Front to Rear 10-4
 - Level the Implement Side to Side 10-5
 - Adjust the Stabilizer 10-5
- 2. Drawbar 10-6
 - Maximum Drawbar Loads 10-6
 - Deploy/Stow the Drawbar 10-6
 - Remove Drawbar 10-7
- 3. Use the Safety Chain 10-7

11.HYDRAULIC SYSTEM..... 11-1

- 1. 3-point Hitch Control System..... 11-1
 - Use the 3-Point Hitch Control Lever 11-1
 - Use the Position Stop Knob 11-2
 - Hydraulic Flow Control/Stop Knob 11-2
- 2. Operate the Implement Control Valve 11-3
 - Implement Control Lever 11-3
 - Implement Control Lever Lock 11-4
 - Connect the Implement Hydraulic Hoses 11-5
 - Disable the "Regen" Function of the Implement Control Valve 11-5

12.TIRES, WHEELS AND WEIGHT 12-1

- 1. Tires 12-1
- 2. Adjust the Wheel 12-2
 - Check the Wheel Bolt Tightening Torque 12-2
 - Select the Front Tire Rolling Direction 12-3
 - Change the Tire Tread Width 12-3
- 3. Remove/Install the Wheels 12-4
- 4. Weight (Option) 12-4
 - Select the Appropriate Amount of Front Weight 12-5
 - Front Weights (option) 12-5
 - Select the Appropriate Amount of Rear Weight 12-6
 - Use the Optional Rear Wheel Weights 12-6
 - Use the Optional Rear Ballast 12-7
 - Use Liquid Weight for the Tires 12-7

TABLE OF CONTENTS

13.MAINTENANCE	13-1
1. Maintenance Check List	13-1
2. Diesel Fuel Specifications	13-3
3. Lubricants	13-4
4. Replacement Parts	13-5
■ Technical Document	13-5
■ Parts	13-5
14.PERIODIC SERVICE	14-1
■ Service the Tractor	14-1
■ Warranty and Repair of the Engine	14-1
1. Open/Close the Hood	14-2
■ Open the Hood	14-2
■ Close the Hood	14-3
2. Daily Checks	14-3
■ Check the Engine Oil Level	14-3
■ Inspect the Transmission Hydraulic Oil Level	14-4
■ Check the Tire Air Pressure	14-5
■ Clean the Front Grille and Side Screens	14-6
■ Check the Fuel Line	14-6
■ Check the Power Steering Line	14-6
■ Check the Retractable Seatbelt	14-6
■ Check the Roll-Over Protective Structure (ROPS)	14-6
■ Check the Headlights, Hazard Lights, etc.	14-6
■ Check and Refill the Fuel Tank	14-7
■ Check and Clean the Rubber Dust Unloading Valve	14-8
■ Check the Radiator Hoses and Clamps	14-8
■ Clean Radiator Cooling Screen	14-9
■ Clean Radiator Cooling Fins	14-9
■ Check the Wheel Bolt Tightening Torque	14-10
■ Inspection Procedure for the Safety Interlock System	14-11
■ Check the Cooling System	14-14
3. Check and Replace as Necessary	14-15
■ Inspect the Alternator/Fan Belt	14-15
■ Check and Replace the Battery	14-15
■ Check the Fuses	14-15
■ Check the Light Bulbs	14-15
■ Check and Drain the Fuel/Water Separator	14-15
4. First 50 Hours	14-16
■ Change the Engine Oil	14-16
■ Replace the Engine Oil Filter	14-16
■ Replace the Transmission Hydraulic Oil Filters	14-16
■ Change the Transmission Hydraulic Oil	14-16
■ Clean the Transmission Hydraulic Oil Strainer	14-16
■ Change the Alternator/Fan Belt	14-16
5. Every 50 Hours	14-16
■ Check the Front Axle Oil Level	14-16
■ Grease Up	14-17
■ Service the Alternator/Fan Belt	14-20
■ Check the Fuel/Water Separator	14-21
■ Check the Battery Condition	14-21

6. Every 100 Hours.....	14-21
■ Service the Air Cleaner Element	14-21
■ Clean the Fuel/Water Separator and Replace the Fuel Filter.....	14-23
7. Every 200 Hours.....	14-24
■ Engine Oil	14-24
■ Change the Engine Oil and Engine Oil Filter.....	14-24
■ Inspect and Adjust the Toe-in.....	14-25
■ Check the Air Intake Hoses and Clamps.....	14-25
8. Every 300 Hours.....	14-26
■ Transmission Hydraulic Oil.....	14-26
■ Change the Transmission Hydraulic Oil and Replace the Transmission Hydraulic Oil Filters and Clean Transmission Hydraulic Oil Strainer.....	14-26
9. Every 500 Hours.....	14-28
■ Change the Front Axle Gear Oil	14-28
■ Replace the Fuel Filter	14-29
■ Adjust the Front Axle Pivot	14-30
■ Adjust the Brake	14-30
10. Every 1000 Hours.....	14-31
■ Service the Cooling System	14-31
■ Recommended Engine Coolant.....	14-33
■ Adjust the Tension of the Throttle Control Lever.....	14-33
■ Adjust the Engine Valve Clearance	14-33
■ Check the Fuel Injection Nozzle.....	14-33
■ Check the Fuel Injection Pump.....	14-33
11. Every 1 Year.....	14-34
■ Replace the Air Cleaner Element	14-34
12. Every 2 Years or 2000 Hours	14-34
■ Replace the Thermostat	14-34
13. General Maintenance.....	14-34

15. SERVICE THE ELECTRICAL SYSTEM..... 15-1

1. Battery.....	15-1
■ Service the Battery Safely	15-1
■ Inspect the Battery.....	15-2
■ Remove and Install the Battery	15-2
■ Clean the Battery and Terminals	15-3
■ Use a Booster Battery	15-3
2. Fuses.....	15-4
■ Replace the Accessory Fuses	15-4
■ Check the Alternator Fuse and the Main Fuse	15-4
3. Bulb	15-5
■ Replace the Headlight Bulb	15-5
■ Replace the Tail Lights Bulb and the Turn Signal/Hazard Lights Bulb	15-5
■ Replace the Sidelights Bulb.....	15-6
■ Replace the Instrument Panel Light Bulb	15-6
4. Headlights	15-7
■ Adjust the Headlights.....	15-7

TABLE OF CONTENTS

16.STORAGE	16-1
1. Safe Practices for Storage	16-1
1. Prepare the Tractor for Storage	16-1
2. Prepare the Fuel and Engine for Storage.....	16-1
■ Fuel.....	16-1
■ Engine	16-2
2. Prepare the Stored Tractor for Operation.....	16-2
17.TROUBLESHOOTING	17-1
1. How to Use the Troubleshooting Table	17-1
1. Engine	17-1
2. Electrical System.....	17-8
3. Brakes	17-10
4. Steering	17-10
5. Body and Machinery.....	17-11
18.INDEX	18-1

1. SAFETY PRECAUTIONS

1. About The Operator's Manual

The *Operator's Manual* presents messages that help the operator remain aware of potential hazards and possible tractor damage in operating and servicing the tractor. Carefully study all of the information in the *Operator's Manual* so that the operator can avoid personal injury or property damage.

NOTE

- Unless otherwise stated, the expressions right hand side, left hand side, front side and rear side, used throughout the *Operator's Manual* are relative to the operator's position.

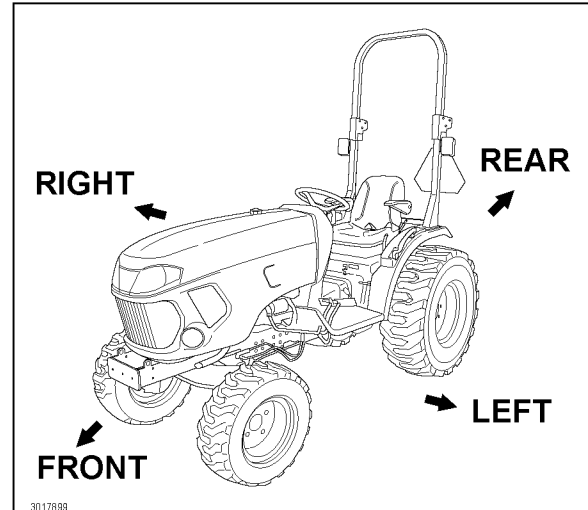

2. Safety Alert Symbol



The safety alert symbol appears with most safety statements. The safety alert symbol means attention, become alert, the operator's safety is involved! Please read and strictly observe the message that follows the safety alert symbol.

DANGER

Indicates a hazardous situation which, if not avoided, **will** result in death or serious injury.

WARNING

Indicates a hazardous situation which, if not avoided, **could** result in death or serious injury.

CAUTION

Indicates a hazardous situation which, if not avoided, **could** result in minor or moderate injury.

NOTICE

Indicates a situation which can cause damage to the tractor, personal property and/or the environment or cause the equipment to operate improperly.

IMPORTANT: Means that implement or property damage could occur if instructions are ignored.

NOTE: Provides useful information.



WARNING: READ AND FOLLOW ALL INSTRUCTIONS IN THE *OPERATOR'S MANUAL* BEFORE ATTEMPTING TO OPERATE THE TRACTOR. FAILURE TO COMPLY WITH THE INSTRUCTIONS MAY RESULT IN PERSONAL INJURY.



WARNING: The engine exhaust, some of its constituents and certain tractor components contain or emit chemicals known to the State of California to cause cancer, birth defects or other reproductive harm.



DANGER: The tractor is built to be operated according to the rules for safe operation in the *Operator's Manual*. As with any type of power equipment, carelessness or error on the part of the operator can result in serious injury. To help prevent accidents, read and take the following precautions before operating the tractor. Failure to observe the following safety instructions could result in serious injury or death.

3. Precautions Before Operating The Tractor

1. Understand the performance and limitations of the tractor. Carefully study the *Operator's Manual* and learn the instructions in the *Operator's Manual* before operating or servicing the tractor. Keep the *Operator's Manual* in an easily accessible place.

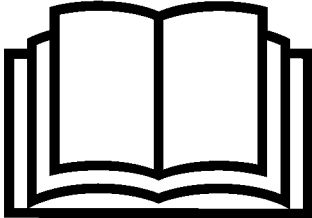

2. Strictly follow the statements given in the DANGER, WARNING and CAUTION safety decals attached to the tractor.
3. Do not operate the tractor with the Roll-Over Protective Structure (ROPS) in the folded "down" position.

Keep the retractable seatbelt fastened while operating the tractor with the Roll-Over Protective Structure (ROPS) in the unfolded "up" position. The preceding practice will reduce the possibility of injury or death in the event of roll over accident.

If the Roll-Over Protective Structure (ROPS) has been removed for any reason, ensure to install all the associated parts before operating the tractor. Do not alter the Roll-Over Protective Structure (ROPS). The altered Roll-Over Protective Structure (ROPS) may fail to provide the designed protection.

Replace the damaged Roll-Over Protective Structure (ROPS) immediately. Contact YOUR LOCAL YANMAR TRACTOR DEALER for technical assistance.

The foldable Roll-Over Protective Structure (ROPS) may be temporarily folded down when absolutely necessary for areas with height limitations. Remember that when the Roll-Over Protective Structure (ROPS) is in the "down" position, the Roll-Over Protective Structure (ROPS) does not provide operator protection and the retractable seatbelt should not be worn. For operator safety, always keep the Roll-Over Protective Structure (ROPS) in the unfolded "up" position and locked securely.

NEVER alter or repair the Roll-Over Protective Structure (ROPS). Welding, bending, drilling, grinding, or cutting may weaken the Roll-Over

Protective Structure (ROPS). Contact YOUR LOCAL YANMAR TRACTOR DEALER for technical assistance.

4. Always fasten the retractable seatbelt while operating the tractor with the Roll-Over Protective Structure (ROPS) in the unfolded "up" position. Check the retractable seatbelt for any damage. Replace the damaged retractable seatbelt immediately. Contact YOUR LOCAL YANMAR TRACTOR DEALER for technical assistance. Do not use the retractable seatbelt if the Roll-Over Protective Structure (ROPS) is in the folded "down" position or the tractor does not have the Roll-Over Protective Structure (ROPS).

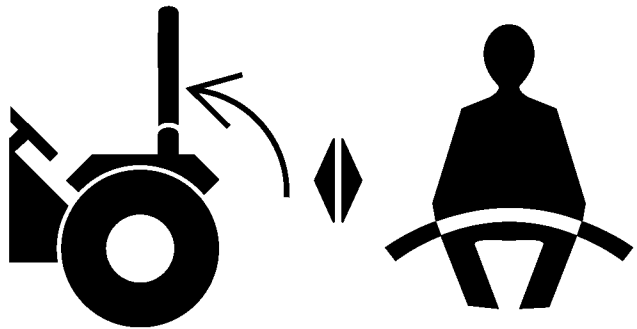

5. Check overhead clearance carefully before driving under power lines, wires, bridges or low hanging tree branches, before entering or leaving buildings, or in any other situation where the operator and/or Roll-Over Protective Structure (ROPS) may be struck, which could result in serious injury.
6. Make sure that the usual operator and any other person who will operate the tractor studies the *Operator's Manual* before operation. Know the controls and how to stop the tractor quickly.
7. Make sure that any person or obstacle is not under or around the tractor before and during operation. Make sure to maintain sufficient overhead clearance above the tractor.
8. Do not operate the tractor and/or implement installed on the tractor while under the influence of alcohol, drugs, medicine or controlled substance/s or when not fit to operate the tractor.
9. During operation and when performing service work:
 - Wear close-fitting clothing.
 - Do not wear loose-fitting clothes, jewelry, baggy or torn clothing.
 - When any of the preceding items is caught by a moving part of the tractor, an accident can happen.

1. SAFETY PRECAUTIONS

- Do not wear cut-off pants or shorts which do not provide protection against flying debris.
 - Do not under any circumstances operate the tractor with bare feet.
 - Do not wear sandals or sneakers.
 - Wear additional protection including non-slip safety boots or shoes, protective goggles and gloves, etc., as appropriate or required by applicable local laws and regulations.
 - Wear ear protection in a noisy environment to prevent hearing damage and to reduce operator fatigue.
10. Avoid allowing passenger/s on any portion of the tractor.
 11. Always remain seated in the operator seat while operating the tractor.
 12. Make sure that the brakes and other mechanical components are properly adjusted and do not have excessive wear.
 - Immediately replace all excessively worn out or damaged components.
 - At regular intervals, check that all nuts, bolts and screws are properly tightened.
(For details, see "Chapter 13. MAINTENANCE" on page 13-1.
 13. Always keep the tractor clean. Dust, grease or grass clippings accumulated on the tractor can lead to fire accidents or personal injury.
- 
14. Use the handholds and running board step when getting on and off the tractor to help prevent

- accidental falls. Keep the running board step clear of mud and debris.
15. Only use the implements that satisfy the requirements in the *Operator's Manual* or are approved by your Yanmar tractor dealer. (For details, see "Chapter 4. IMPLEMENT CAPACITIES" on page 4-1).
16. When using front, mid- or rear mounted implements, install an appropriate weight/s to the front or rear of the tractor to prevent upsetting the tractor. When using the mid-implement, the operator may use front and rear weights. If the operator choose to use the loader, mount an implement or weight to the 3-point hitch in order to stabilize the tractor. Observe the instructions about safety in the *Operator's Manual* for the implement to be used.
17. Remember that a narrower tire tread width can lead to greater possibility of upsetting the balance of the tractor. To positively stabilize the tractor, select a maximum possible tire tread width appropriate for the intended application. (For details, see "Change the Tire Tread Width" on page 12-3).
18. Do not under any circumstances modify the tractor. Modification can deteriorate the performance and/or safety of the tractor, possibly leading to personal injury or property damage.
19. Do not attempt to adjust the low or high idle speed limit screw. Adjusting the low or high idle speed limit screw may impair the safety and performance of the tractor and shorten the life of the tractor.

4. Safe Practices for Operating the Tractor

1. Start the Tractor

1. Remain seated in the operator seat when starting the engine or actuating the levers or controls. Do not start the engine or operate controls while standing beside the tractor.
2. Before starting the engine, ensure that all the levers are in the N (neutral) positions, the parking brake is engaged securely, and Power Take Off (PTO) switch is in the OFF position.
3. Always keep the retractable seatbelt fastened around the operator's waist whenever the Roll-Over Protective Structure (ROPS) is in the unfolded "up" position and locked securely.
4. If the tractor is started where there is a height limitation, immediately return the Roll-Over Protective Structure (ROPS) to the unfolded "up" position and locked securely and fasten the retractable seatbelt.
5. Start the engine of the tractor only by using the starter key switch. Avoid starting the engine by short circuiting across the starter solenoid terminals with a jumper wire, or by bypassing the safety start switch. This defeats the safety interlock circuit and the tractor may begin to move and/or the Power Take Off (PTO) shafts may begin to rotate, possibly leading to personal injury or property damage.

1. SAFETY PRECAUTIONS

6. Avoid running or idling the engine in a confined area that is poorly ventilated or not ventilated at all. The engine emits carbon monoxide gas that is colorless, odorless and can cause death.



7. Before operation, check that all the safety features are functioning correctly. Never tamper with safety devices. Check the proper operation regularly. Contact YOUR LOCAL YANMAR TRACTOR DEALER for safety devices malfunction.
8. Avoid accidental contact with control pedals while the engine is running, as this can cause unexpected movement of the tractor.
9. Always attend to the running tractor.

2. Work with the Tractor

1. Tow an implement only with the drawbar. Avoid hitching via the axle housing. The tractor can upset its balance, leading to serious injury or death. Make sure the drawbar pin is locked in place.
2. Any towed vehicle with the total weight exceeding that of the tractor should be equipped with its own braking system that is operational from the tractor operator seat.
3. Make sure that all the covers and guards are in position. Replace any missing or damaged covers immediately.
4. Before turning or during traveling on a rough terrain, or before stopping, decrease the tractor speed in order to prevent upsetting.
5. Use extra caution during operating over rough ground, when crossing ditches or operating on slopes and when turning corners.
6. Avoid turning with the differential lock engaged. Attempting to turn the tractor while the differential lock is engaged can lead to a roll over.
7. Stay clear of ditches, potholes, embankments or ponds. The incident of upsetting the tractor can occur more on soft or wet ground. Before entering an area covered with tall grass, inspect the area to detect any obstacles.

8. The operator should always pay attention for blind corners, trees and other object that can obstruct the operator's vision. The operator should always remain alert when approaching the row of trees or any obstacle.
9. When two or more people are working in one area, always keep in good communication between each other.
10. Do not under any circumstances get on or off the moving tractor.
11. When driving at night, ensure that all necessary lights are illuminated.
12. When driving, do not shift the range gear. Always shift the range gear when the tractor is completely stopped.

3. Stop the Tractor

The procedures of stopping the tractor are as follows:

1. Make sure that the left side brake pedal and the right side brake pedal are connected with the brake pedal connector lock.
2. Reduce the engine speed.
3. Release the forward and reverse drive pedals completely.
4. Depress the brake pedals to stop the tractor.
5. Move the primary gear to the N (neutral) position.

4. Considerations for Safety of a Child

Tragic accidents can occur if the operator is not alert to the presence of a child. A child is often attracted to the tractor. A child does not understand the dangers. Never assume a child will remain where the operator last saw the child.

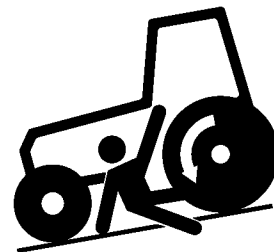

1. Keep a child out of the operating area and under the watchful care of an adult other than the operator.
2. Be alert if a child enters the work area, stop the tractor immediately.

1. SAFETY PRECAUTIONS

3. Never allow a child to ride on the tractor. The child can fall off and be seriously injured or interfere with safe tractor operation.
4. Never allow a child under 16 years old to operate the tractor. A child, 16 years old and under should only operate the tractor under close parental supervision and proper instruction.
5. Be extremely careful when backing the tractor. Before and during backing, look back and downward. A child may be in the path.
6. Use extra care when approaching blind corners, shrubs, trees or other objects that may obscure the operator's vision of a child or other hazard.
7. Never allow a child to play on the tractor or implement.
8. Keep a child away from hot or running engine. The child may suffer burns.

5. Operate the Tractor on Slopes

On a slope, the tractor is less stable and more prone to tip over, possibly leading to serious injury or death. Remain very cautious while the tractor is on any slope.

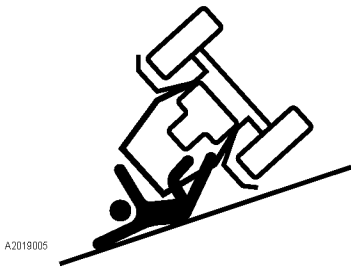

DO:

- Operate up and down slopes, not across.
- Remove obstacles such as rocks, limbs, etc.
- Watch for potholes, ruts or bumps. Uneven terrain can overturn the tractor. Tall grass can hide such obstacles.
- Place the transmission in the low range when climbing or descending slopes. Always keep the tractor in gear when going down slopes to take advantage of engine braking action.
- Keep all movement on the slopes slow and gradual. Do not make sudden changes in speed or direction. Rapid engagement or braking can cause the front of the tractor to lift and rapidly tip over backwards which can cause serious injury.
- Avoid starting or stopping on a slope. If tires lose traction, push down Power Take Off (PTO) switch to OFF position and proceed slowly straight down the slope.
- To avoid upset, move backward up a steep slope. If backing on the slope is difficult, do not attempt to continue. Avoid an extremely steep slope.
- When moving forward to get out from a ditch, deep mud or when traveling on a steep slope, the risk of the tractor upsetting backward is high. Always move backward to get out from these situations. In the 4-wheel drive mode, special caution is needed

to avoid false confidence in the tractor's ability to climb slopes.

- To improve stability on a slope, select the widest possible tire tread width. Observe the instructions for appropriate weighting.

DO NOT:

- Keep away from drop-offs, ditches or embankments during mowing. The mower could suddenly turn over if a wheel goes over the edge of a cliff, ditch or if an edge caves in.

WARNING

- Before approaching a slope, select an appropriate speed setting. Make sure to run the tractor at a lower speed on slopes. Never attempt to shift gears on a slope. The tractor can suddenly go downhill out of control. Avoid increasing and decreasing the tractor speed rapidly.
- Do not move the range gear lever in the N (neutral) position when on a slope.
- When climbing or descending a slope, do not shift the range gear lever. Shifting the range gear lever into the N (neutral) position can result in loss of control of the tractor.
- Starting the tractor with the front end uphill can cause the front wheels to jump off the ground and this situation poses an extreme danger. To avoid this problem, run the engine at a lower speed, and gently start the tractor.
- Avoid parking the tractor on a slope. If parking on a slope is unavoidable, chock all the tires safely and securely and engage the parking brake securely, for details, see "6. Lock and Set the Parking Brake" on page 7-3.
- Avoid moving the range gear lever to N (neutral) position while operating on a slope.

6. Travel on a Road

1. Disengagement of the 4-wheel drive is recommended.
2. Remember that the braking characteristics differ between the 2-wheel drive and 4-wheel drive modes. Be aware of the current drive mode and use carefully.
3. Depress the forward and reverse drive pedals slowly.
4. Before turning, always slow down the tractor. High speed turn may cause the tractor to tip over.
5. When traveling on a road, ensure that the Slow Moving Vehicle (SMV) emblem is on the rear of tractor and is clearly visible. Use the hazard lights and turn signal lights as required by the currently effective local laws or regulations.
6. Strictly observe all the currently effective local traffic and safety laws and regulations.
7. Turn ON the headlights as required by the currently effective local laws or regulations.
8. Always travel at a speed that allows the operator to maintain control of the tractor.
9. Avoid engaging differential lock while traveling on a road. It may cause the operator to lose control of the tractor.
10. While traveling on a road, do not turn the steering wheel suddenly. Such an action can lead to loss in the stability of the tractor and can cause an extremely dangerous situation.
11. While on a road, do not attempt to operate an implement. During transportation, place the 3-point hitch control lever in the raised position and lock the 3-point hitch control lever with the position stop knob. Do not fully close the hydraulic flow control/stop knob to hold an implement in the raised position while the tractor is traveling with the implements. The preceding action can cause damage to the hydraulic lift circuit.
12. When towing implement, connect a safety chain to the implement and mount a Slow Moving Vehicle (SMV) emblem on the rear of the tractor.

7. Safe Practices for Parking the Tractor

1. Push down Power Take Off (PTO) switch to OFF position, lower the implements to the ground, move all the levers to N (neutral) position, engage the parking brake securely, for details, see "6. Lock and Set the Parking Brake" on page 7-3, shut off the engine and remove the key.
2. Before leaving the tractor, ensure that the tractor is completely stopped.
3. Avoid parking the tractor on a steep slope. Rather, park on solid and level ground whenever possible. If parking on a slope is unavoidable, park the tractor across the slope and lower the implement to the ground and chock all the tires safely and securely.

8. Operate the Power Take Off (PTO)

1. Before connecting/disconnecting, adjusting, cleaning or servicing Power Take Off (PTO) driven implement, ensure that all the moving components are not moving.
2. Make sure that Power Take Off (PTO) shaft cap is always in place. Replace Power Take Off (PTO) shaft cap only when the shaft is not moving.
3. Before installing or operating the Power Take Off (PTO) driven implement, carefully study the *Operator's Manual* of the implement and the safety decals on the implement.
4. When installing stationary Power Take Off (PTO) driven implements, ensure to engage the parking brake securely, for details, see "6. Lock and Set the Parking Brake" on page 7-3, chock all the tires safely and securely. Avoid approaching or accessing any rotating component.
5. Make sure to remove the drawbar before using the Power Take Off (PTO).



9. Use the 3-Point Hitch

1. Use the 3-point hitch only in conjunction with the implement that is specifically designed for use with the 3-point hitch.
2. Before using the 3-point hitch mounted implement, the appropriate weight may need to be installed on the front of the tractor.
3. While on a road, do not attempt to operate an implement. During transportation, place the 3-point hitch control lever in the raised position and lock the 3-point hitch control lever with the position stop knob.
Do not fully close the hydraulic flow control/stop knob to hold an implement in the raised position while the tractor is traveling with the implement. The preceding action can cause damage to the hydraulic lift circuit.

10. Roll-Over Protective Structure (ROPS) Precautions

The tractor is equipped with a Roll-Over Protective Structure (ROPS) which must be maintained in a fully functional condition. Check overhead clearance carefully before driving under power lines, wires, bridges or low hanging branches, before entering or leaving buildings, or in any other situation where the operator and/or Roll-Over Protective Structure (ROPS) can be struck, which can result in serious injury.

1. Always keep the Roll-Over Protective Structure (ROPS) on its original condition.
2. Replace the Roll-Over Protective Structure (ROPS) whenever the Roll-Over Protective Structure (ROPS) has been damaged. The preceding action can weaken the structure and endanger the safety of the operator.
3. Use only genuine parts to replace any damaged part/s of the Roll-Over Protective Structure (ROPS).
4. Never attach ropes, chains or cables to the Roll-Over Protective Structure (ROPS) for pulling purposes.
5. Although the Roll-Over Protective Structure (ROPS) provides the maximum protection possible, always take necessary precautions.

11. Safe Practices for Servicing the Tractor

Before starting any service work, park the tractor on solid and level ground, engage the parking brake securely, for details, see "6. Lock and Set the Parking Brake" on page 7-3, lower the implement to the ground, move all the levers to N (neutral) position, push down Power Take Off (PTO) switch to OFF position, shut off the engine and remove the key.

1. Always keep a first aid kit and a fire extinguisher readily available.
2. Before accessing the engine, muffler, radiator and radiator cap or other possibly hot components, wait until the tractor has fully cooled down.



3. Use extreme care in handling diesel fuels. Diesel fuels are extremely flammable and the vapors are explosive. Use only a container approved by the local effective law.
4. Make sure to shut off the engine before refueling. After refueling, replace fuel filler cap securely and wipe off any spilled diesel fuel before starting the engine as the diesel fuel may cause a fire or explosion.
5. Do not smoke while refueling. Keep any spark or open flame away from the fuel tank.
6. Never refuel the tractor indoors because diesel fuel vapors will accumulate in the area.
7. Never store the fuel container or tractor indoor where there is an open flame or spark, such as a gas water heater, space heater or furnace.
8. Do not smoke while working around the battery. Keep any sparks or open flame away from the battery. The battery emits hydrogen and oxygen gasses, in particular during recharging and can pose a hazard of explosion.



9. Prior to "jump starting" a tractor that has fully depleted battery, read and follow all the instructions in "Chapter 15. SERVICE THE ELECTRICAL SYSTEM" on page 15-1.
10. Add coolant or water to the reserve tank, not to the radiator (For details, see "Check the Cooling System" on page 14-14).



11. Before working on or around electrical components, disconnect the negative (-) battery terminal first.
12. To prevent a spark occurring from short circuit, disconnect the negative (-) battery terminal first and reconnect last.

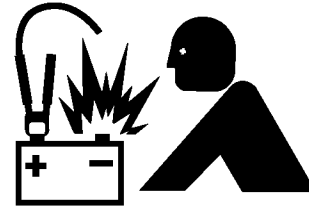

13. The operator must not mount a tire onto a rim. Only qualified person must mount tire onto a rim.
14. Always keep the tires at the correct tire air pressure level. Avoid exceeding the recommended tire air pressure specified in the *Operator's Manual*.

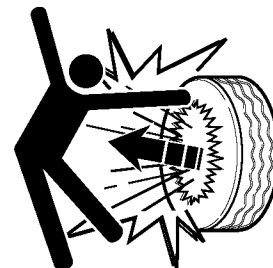

15. Keep the tractor securely supported while changing the wheels or adjusting the tire tread width. Make sure to tighten the wheel bolts to the specified tightening torque.

1. SAFETY PRECAUTIONS

16. Avoid working under any hydraulically supported devices. Such devices can leak, suddenly settle down, or be accidentally lowered. If working beneath the tractor or an implement is unavoidable, ensure to use a stand or lift apparatus with the capacity of more than 3 tons.
17. High pressure hydraulic fluid when released can penetrate human skin, possibly leading to serious personal injury. Before disconnecting any hydraulic line, fully release the internal pressure. Before exerting a pressure to the hydraulic system, ensure that all connections are tight and all the lines, pipes and hoses are free from fractures/fissures or any other damage.

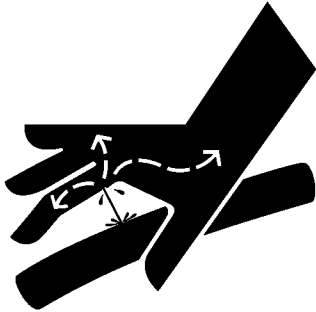

18. Check brake operation frequently. Adjust and service as required.



WARNING: THE OWNER/OPERATOR RESPONSIBILITY: Restrict the use of the tractor to persons who read, understand and follow the warnings and instructions in the *Operator's Manual* and on the tractor.

19. Avoid changing the engine governor settings or overspeed the engine. Excessive engine speeds are dangerous.
20. Observe proper waste disposal laws and regulations. Prior to disposal, determine the proper method to dispose of waste from your local Environmental Protection Agency. Recycling centers are established to properly dispose of materials in an environmentally safe fashion.
21. Use container approved by the effective law when draining fluids. Avoid using food or beverage containers that can mislead someone into drinking from food or beverage containers. Properly dispose of the containers immediately following the draining of fluids.
22. Observe your local Environmental Protection Agency regulations when disposing of oil, fuel, coolant, brake fluids, filters, batteries, tires and other harmful waste.
23. Yanmar does not recommend the use of a pressure washer or garden hose to clean the tractor. Electrical components, spindles, pulleys, bearings or the engine can be damaged. The use of water will result in shortened life and reduce serviceability.

12. Replace the Rubber Product/s, such as Hydraulic Hose, Fuel Hoses, Power Steering Hoses, Radiator Hoses and Air Intake Hose for Every 2 Years

The rubber product/s has/have a deteriorative character. The deteriorated rubber product/s may cause defects and damages such as fluid leakage, loss control of the tractor during operation, fire, burn injury.

13. Understand the Tractor Safety Decals

■ Safety Alert Symbol

The tractor safety decals illustrated in this section are provided in critical areas on the tractor so that people including the operator can remain always aware of potential hazards.

The tractor safety decals contain the words DANGER, WARNING and CAUTION together with the safety alert symbol. DANGER and WARNING stand for the most serious hazards.

The *Operator's Manual* also contains special safety messages that explain potential hazards about which the operator must remain cautious. The messages are presented together with the word CAUTION and the safety alert symbol.

■ Care of DANGER, WARNING and CAUTION Decals

1. Always keep all the DANGER, WARNING and CAUTION decals clean and clearly legible.
2. Clean the DANGER, WARNING and CAUTION decals with soap and water, wipe dry with clean soft cloth.
3. Replace damaged or missing DANGER, WARNING and CAUTION decals with new decals available from YOUR LOCAL YANMAR TRACTOR DEALER.
4. If a component having a DANGER, WARNING and CAUTION decals is replaced with a new decal, ensure that the new decal is on the same location as of the old component.
5. Affix a new DANGER, WARNING and CAUTION decals flat on a clean and dry surface, squeezing out trapped air.

1. SAFETY PRECAUTIONS

(A) 1A7340-65850

WARNING

ROLL-OVER HAZARD!

- NEVER operate without seatbelt fastened.
- NEVER jump if machine tips.
- NEVER remove, repair or modify ROPS.
- ALWAYS replace a damaged ROPS.
- Failure to comply could result in death or serious injury.

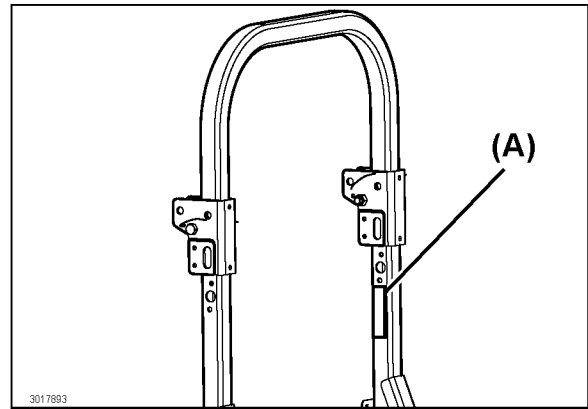

1. SAFETY PRECAUTIONS

(B) 1A8300-65320

WARNING

1. Read Operator's Manual before operating this tractor.
2. Do not operate the machine without guards, shields and safety devices in place and working.
3. Hitch towed loads only to drawbar to avoid rearward upset.
4. Make certain everyone is clear of machine before starting engine or operation.
5. Keep all riders off tractor and equipment.
6. Keep hands, feet and clothing away from power-driven parts.
7. Fasten seat belt while operating tractor.
8. Reduce speed when turning or operating around hazards, on rough ground or steep slopes.
9. Couple brake pedals together for road travel.
10. Do not allow operation of the machine by untrained personnel.
11. Use flashing warning lights on highway unless prohibited by law.
12. Stop engine, lower implement to ground and lock park brake before dismounting.
13. Wait for all movement to stop before servicing machinery.
14. Remove key if leaving tractor unattended.
15. Securely support tractor and implements before working underneath.

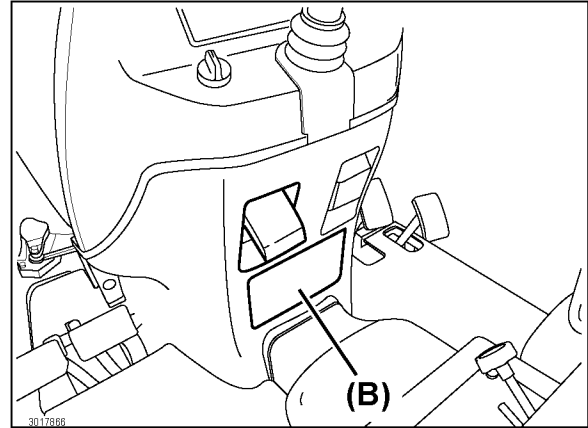

WARNING

1. Read Operator's Manual before operating this tractor.
2. Do not operate the machine without guards, shields and safety devices in place and working.
3. Hitch towed loads only to drawbar to avoid rearward upset.
4. Make certain everyone is clear of machine before starting engine or operation.
5. Keep all riders off tractor and equipment.
6. Keep hands, feet and clothing away from power-driven parts.
7. Fasten seat belt while operating tractor.
8. Reduce speed when turning or operating around hazards, on rough ground or steep slope.
9. Couple brake pedals together for road travel.
10. Do not allow operation of the machine by untrained personnel.
11. Use flashing warning lights on highway unless prohibited by law.
12. Stop engine, lower implement to ground, and lock park brake before dismounting.
13. Wait for all movement to stop before servicing machinery.
14. Remove key if leaving tractor unattended.
15. Securely support tractor and implements before working underneath.

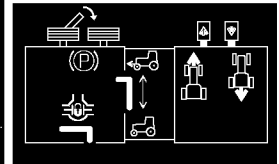

1. SAFETY PRECAUTIONS

(C) 1A8160-65310

 WARNING
TO AVOID INJURY: Before leaving or servicing machine, <ul style="list-style-type: none">● Stop engine.● Set parking brake.● Park on level ground.● Lower all implements to the ground.● Remove key.

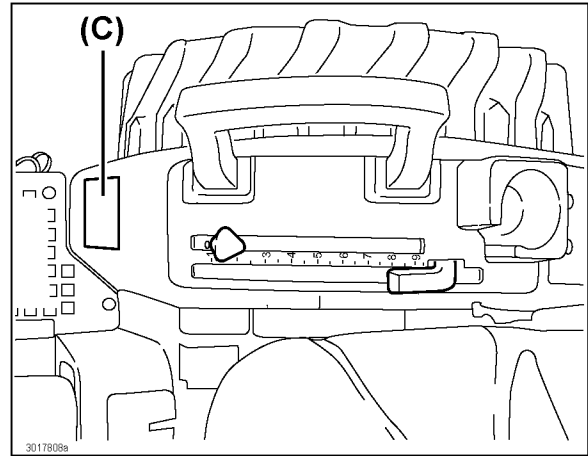



 WARNING	TO AVOID INJURY: Before leaving or servicing machine, <ul style="list-style-type: none">• Stop engine.• Set parking brake.• Park on level ground.• Lower all implements to the ground.• Remove key.
	
<small>1A8160-65310</small>	

(D) 1A8160-65300

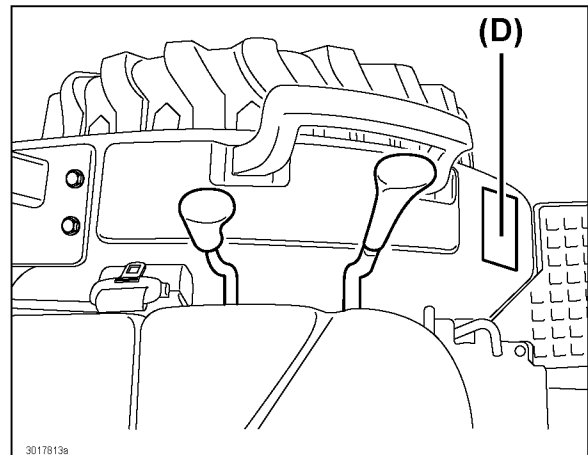
 DANGER
TO AVOID INJURY OR DEATH: <ul style="list-style-type: none">● Do not start engine by shorting across starter terminals or bypassing safety start switch.● Start engine only from seat with transmission and PTO OFF.



 DANGER	TO AVOID INJURY OR DEATH: <ul style="list-style-type: none">• Do not start engine by shorting across starter terminals or bypassing safety start switch.• Start engine only from seat with transmission and PTO OFF.
	
<small>1A8160-65300</small>	

1. SAFETY PRECAUTIONS

(E) 1A8160-51520

DANGER

- SHIELD EYES. EXPLOSIVE GASES CAN CAUSE BLINDNESS OR INJURY.
- NO SPARKS, FLAMES, SMOKING.
- SULFURIC ACID CAN CAUSE BLINDNESS OR SEVERE BURNS.
- FLUSH EYES IMMEDIATELY WITH WATER. GET MEDICAL HELP FAST.
- KEEP OUT OF REACH OF CHILDREN. DO NOT TIP. DO NOT OPEN BATTERY!

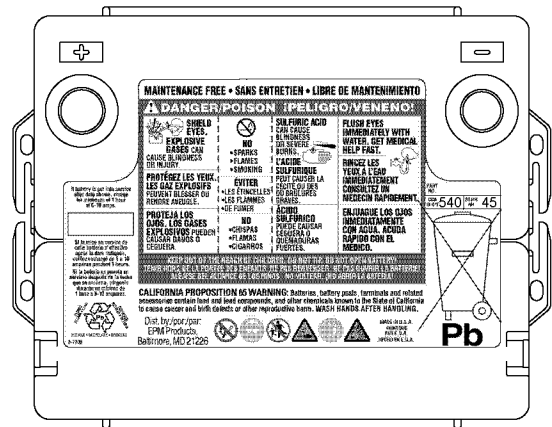
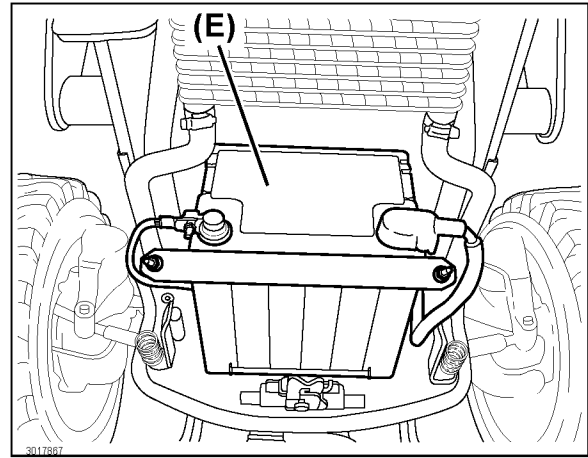

(F) 1A7880-65610

WARNING

- STAY CLEAR OF ENGINE FAN AND FAN BELT.

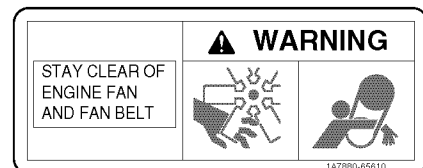
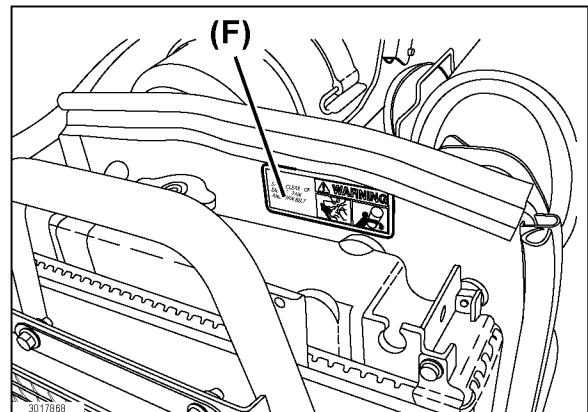

1. SAFETY PRECAUTIONS

(G) 198220-65621

WARNING

AVOID INJURY FROM PTO:

- Keep all shields in place.
- Keep hands, feet and clothing away.
- Operate only with 540 RPM.

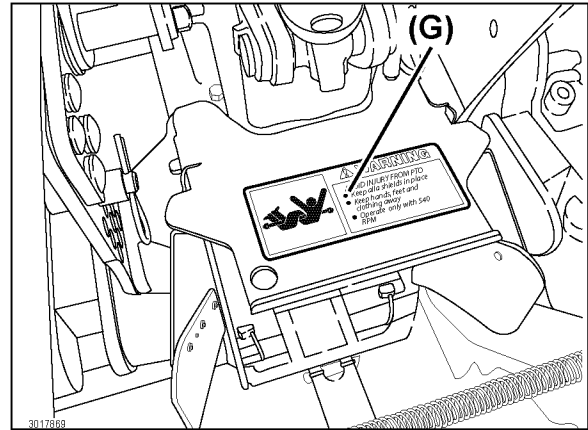

2. SERVICE THE TRACTOR

Your Yanmar tractor dealer is committed to provide reliable and quality services to the tractor. Through the preceding services, the full performance potential of the tractor can be realized.

After carefully studying the contents of the *Operator's Manual*, the tractor owner/operator can perform certain regular maintenance work.

- Exercise caution so as not to injure the operator and other persons.
- Do not attempt to do work that is beyond the owner/operator capability and knowledge.

When in doubt, always consult YOUR LOCAL YANMAR TRACTOR DEALER.

For information about servicing, contact YOUR LOCAL YANMAR TRACTOR DEALER.

For new parts and components and major service work, contact YOUR LOCAL YANMAR TRACTOR DEALER for technical assistance.

When ordering a part or component, always provide the serial numbers of the following to YOUR LOCAL YANMAR TRACTOR DEALER:

- Tractor
- Engine
- Roll-Over Protective Structure (ROPS)

(A) Tractor identification plate with tractor serial number

(B) Engine serial number

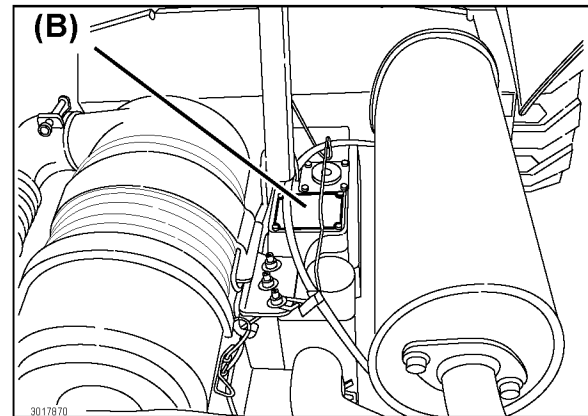
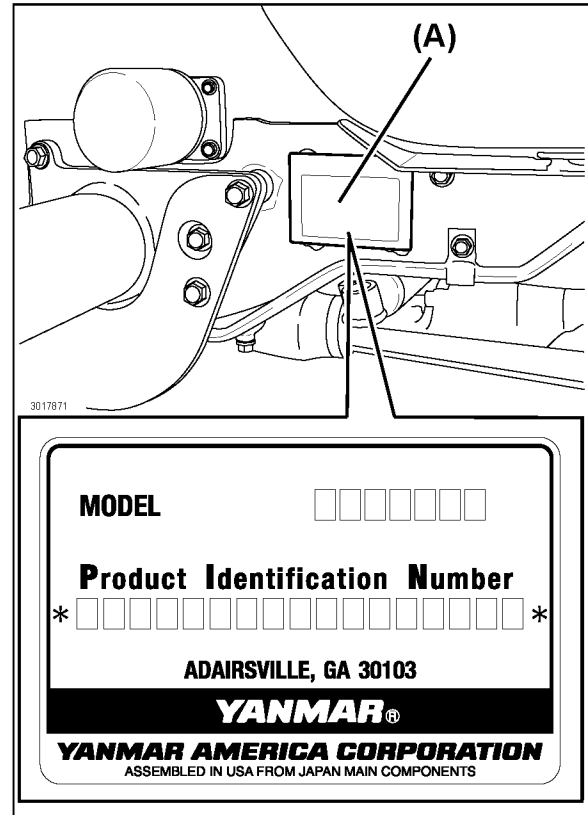

2. SERVICE THE TRACTOR

After accepting delivery of the tractor, immediately find the serial numbers and enter the numbers into the following table.

- The information in the table must come in handy, if for some reason, the serial numbers on the tractor are covered, erased or become illegible.

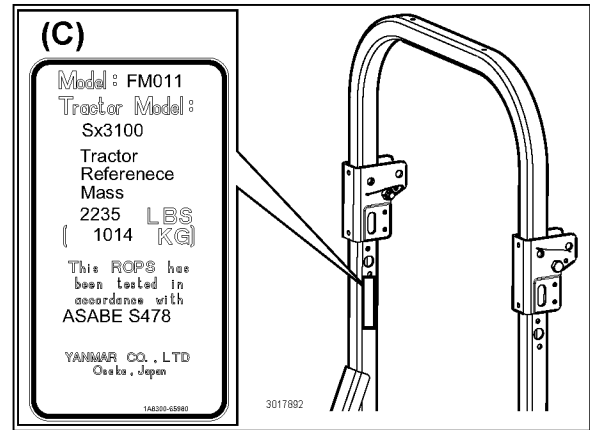

	Type/Model	Serial No.
Tractor		
Engine		
Roll-Over Protective Structure (ROPS)		
Date of Purchase		
Name of Dealer		

*(C) Roll-Over Protective Structure (ROPS) model
 (D) Roll-Over Protective Structure (ROPS) serial
 number*

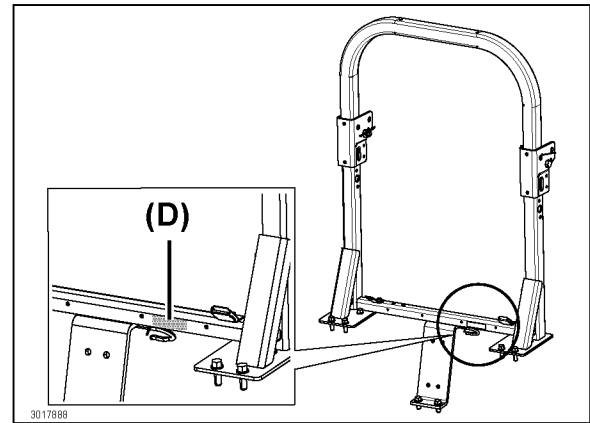

3. SPECIFICATIONS

1. Specifications Table

Model			Sx3100	
Power Take Off (PTO) Power		hp (kW)	23.5 (17.5)	
Engine	Maker		YANMAR	
	Model		3TNV88-BNJK	
	Type		4 Cycle Inline, Water-Cooled Diesel	
	Number of Cylinders		3	
	Bore and Stroke		in. (mm) 3.46 × 3.54 (88 × 90)	
	Total Displacement		cu. in. (L) 100.2 (1.642)	
	Gross Power		hp (kW) 31.2 (23.3)	
	Net Power		hp (kW) 30.0 (22.4)	
	Rated Revolution		min ⁻¹ (rpm) 2500	
	Maximum Torque		ft•lbs (N•m) 73-3 - 79.0 (98 - 107)	
	Battery		540 CCA, 12 - 37 (5Hr) Deka: D25233D	
	Fuel		Diesel Fuel	
Capacities	Fuel Tank		US gal (L) Approximately 7.1 (27)	
	Engine Oil		US qt. (L) Approximately 3.6 (3.4)	
	Engine Coolant		US qt. (L) Approximately 2.1 (2.0)	
	Transmission Oil		US gal (L) Approximately 4.6 (17.5)	
Dimensions	Overall Length (without 3-Point Hitch)		in. (mm) 108.9 (2766)	
	Overall Width (with R4 Tires)		in. (mm) 50.7 (1287)	
	Overall Height (with Roll-Over Protective Structure (ROPS), R4 Tires)		in. (mm) 95 (2407)	
	Overall Height (with R4 Tires) (Top of Steering Wheel)		in. (mm) 52.8 (1341)	
	Wheel Base		in. (mm) 65.2 (1655)	
	Min. Ground Clearance (with R4 Tires)		in. (mm) 10.6 (268)	
	Tread (with R4)	Front	in. (mm) 36.2 (920)	
Rear		in. (mm) 37.6 (956)		
Weight (with Roll-Over Protective Structure (ROPS) and R4 Tires)			lb. (kg) 2093 (948)	
Traveling System	Tire	Ag (R1)	Front	N/A
			Rear	N/A
		Turf (R3)	Front	24 × 8.50-14 4PR
			Rear	36 × 14-15 4PR
		Industrial (R4)	Front	23 × 8.50-12
			Rear	14-17.5

3. SPECIFICATIONS

Traveling System	Clutch		N/A	
	Steering		Full Independent	
	Transmission		Hydrostatic Transmission, 2 Range Speeds	
	Brake		Wet Disc	
	Minimum Turning Radius	ft. (m)	8.2 (2.5)	
Hydraulic Unit	Hydraulic Control System		Position Control, Open Center	
	Pump Capacity (main)	US gal/min (L/min)	Approximately 4.8 (18.1)	
	Pump Capacity (steering)	US gal/min (L/min)	Approximately 5.3 (20.0)	
	3-Point Hitch		Category 1	
	Max. Lift Force	Lift Point	lb. (kg)	1429 (650)
		24 in. Behind Lift Point	lb. (kg)	1209 (550)
System Pressure		psi (MPa)	2429 (16.7)	
Power Take Off (PTO)	Rear	Shaft Size	SAE 16/32, 15-Splines	
		Type	Independent	
		Speed / Engine	min ⁻¹ (rpm)	541 / 2500
	Mid	Shaft Size	SAE 16/32, 15-Splines	
		Type	Independent	
		Speed / Engine	min ⁻¹ (rpm)	2118/2500

2. Traveling Speeds

(At rated engine min⁻¹ (rpm))

	Range gear lever	Approximate rated speed	
		mph	km/h
Forward	Low	4.6	7.3
	High	13.2	21.1
Reverse	Low	4.6	7.3
	High	13.2	21.1

NOTE

● The listed traveling speeds are those obtained with tire R3.

4. IMPLEMENT CAPACITIES

- Prior to delivery, the tractor is subjected to the load tests described below.
- The tests are designed to ensure the tractor performs safely and to specification when subjected to various loads and stresses.
- Genuine implements approved by Yanmar are used.

IMPORTANT

- Use only implements approved by YOUR LOCAL YANMAR TRACTOR DEALER.
- All implements used must conform to the approved specifications, per below.
- Using unapproved implements can result in malfunction, failure and damage to the tractor.
- The preceding action can also increase the possibility of injury to the operator or other people. The Yanmar warranty does not cover any malfunction or failure that results from the use of an unapproved implement.

	Lower Link End Maximum Lifting Capacity	Implement Weight and Size	Maximum Drawbar Load	Trailer Loading Weight Maximum Capacity
	W_0	W_1	W_2	W_3
lb.	1429	As specified in the list shown in the next page	529	1323
kg	650		240	600

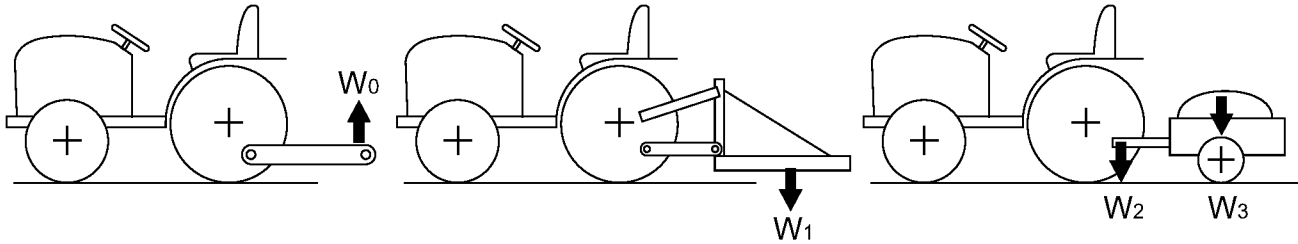

A3013714

4. IMPLEMENT CAPACITIES

Implement		Description	Unit	Maximum Amount
Trailer		Load Capacity	lb. (kg)	1323 (600)
		Drawbar Load	lb. (kg)	529 (240)
Mower	Rotary-Cutter	Cutting Width	in. (mm)	60 (1525)
		Weight	lb. (kg)	598 (271)
	Finish Mower	Cutting Width	in. (mm)	60 (1525)
		Weight	lb. (kg)	507 (230)
Rotary Tiller		Tilling Width	in. (mm)	66 (1576)
		Weight	lb. (kg)	510 (231)
Box Scraper		Cutting Width	in. (mm)	60 (1525)
		Weight	lb. (kg)	554 (251)
Rear Blade		Cutting Width	in. (mm)	60 (1525)
		Weight	lb. (kg)	294 (133)
Landscape Rake		Cutting Width	in. (mm)	60 (1525)
		Weight	lb. (kg)	250 (113)
Loader		Lift Capacity (at Pivot)	lb. (kg)	948 (430)
		Bucket Weight	lb. (kg)	141 (64) / 156 (71)
		System Pressure	psi (MPa)	2428 (17.2)
Backhoe		Digging Depth	ft. (mm)	6.5 (1981)
		Weight	lb. (kg)	1190 (540)
		Oil Pressure	psi (MPa)	2428 (17.3)

5. NAMES AND FUNCTIONS OF COMPONENTS

1. Overview

Names of Main Components

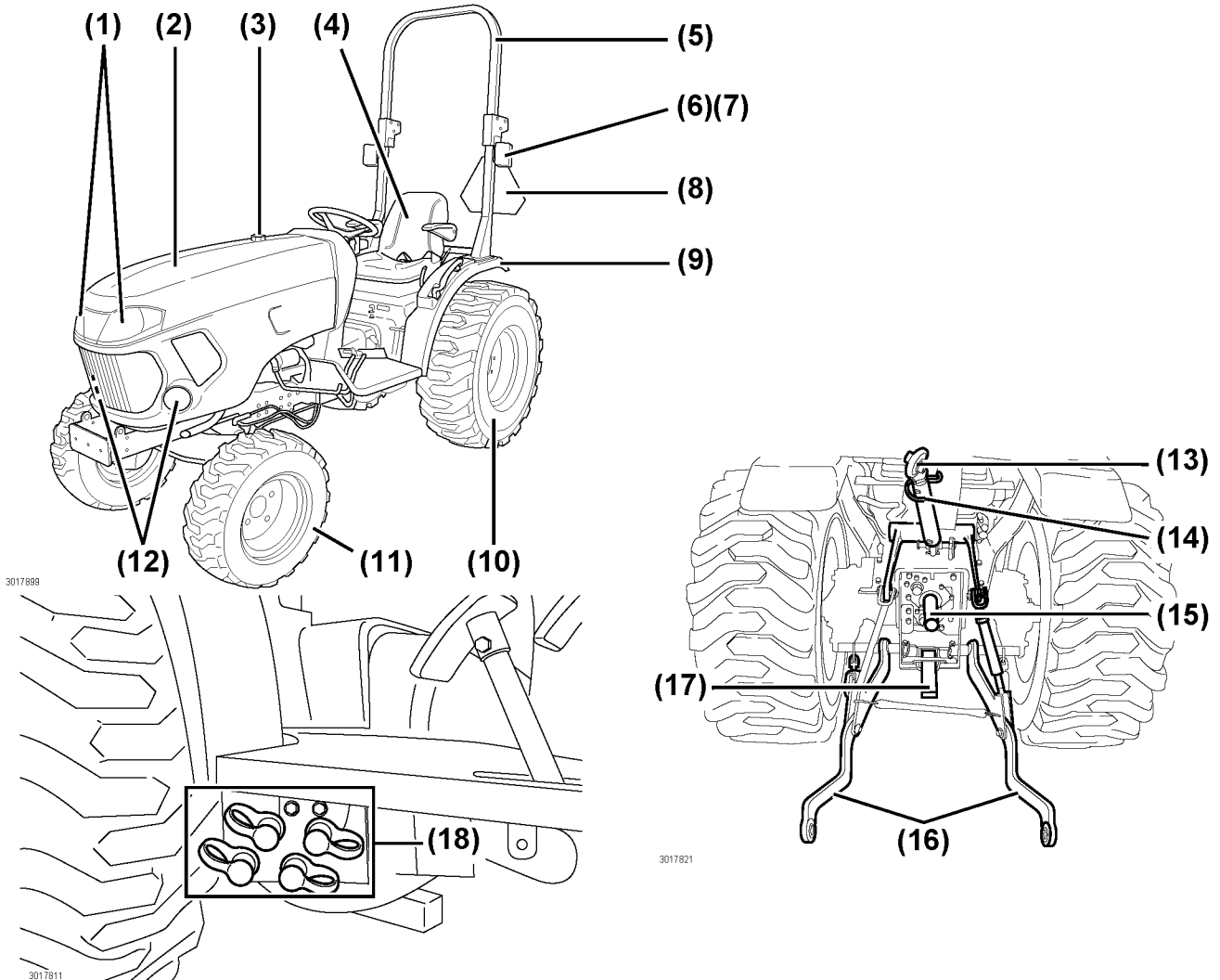

- (1) Headlights
- (2) Hood
- (3) Fuel filler cap
- (4) Operator seat
- (5) Roll-Over Protective Structure (ROPS)
- (6) Turn signal/hazard lights
- (7) Tail lights
- (8) Slow Moving Vehicle (SMV) emblem
- (9) Fender

- (10) Rear tires
- (11) Front tires
- (12) Sidelights
- (13) Top link
- (14) Top link hook
- (15) Power Take Off (PTO) shaft
- (16) Lower links
- (17) Drawbar
- (18) Hydraulic quick couplers

■ Functions of Main Components

(1) Headlights

Provide illumination in front of the tractor.

(2) Hood

Covers and protects the engine.

(3) Fuel filler cap

Where the fuel nozzle is inserted to fill up the fuel tank.

(4) Operator seat

Sits the operator and from where the operator can easily control the tractor instruments.

(5) Roll-Over Protective Structure (ROPS)

Protect the operator in the event of an accident such as a roll over.

(6) Turn signal/hazard lights

Use to warn people that tractor is about to turn left or right. Use to warn people of an emergency situation.

(7) Tail lights

Provide illumination at the rear of the tractor.

(8) Slow Moving Vehicle (SMV) emblem

Identify the tractor as a slow moving vehicle to other motorists.

(9) Fender

Keeps mud away from the operator.

(10)Rear tires

Supports the back part of the tractor and allows the tractor to roll.

(11)Front tires

Support the front part of the tractor and allows the tractor to roll.

(12)Side lights

Provide illumination at the side of the tractor.

(13)Top link

Use to adjust angle or position of an implement.

(14)Top link hook

Hold the top link when the top link is not in use.

(15)Power Take Off (PTO) shaft

Transmit rotational force from the tractor to an implement.

(16)Lower links

Connects and holds an implement.

(17)Drawbar

Use to pull/tow an implement.

(18)Hydraulic quick couplers

Use to connect the tractor's hydraulics to the implement's hydraulic cylinders.

2. Operator Station Controls

Names of Components

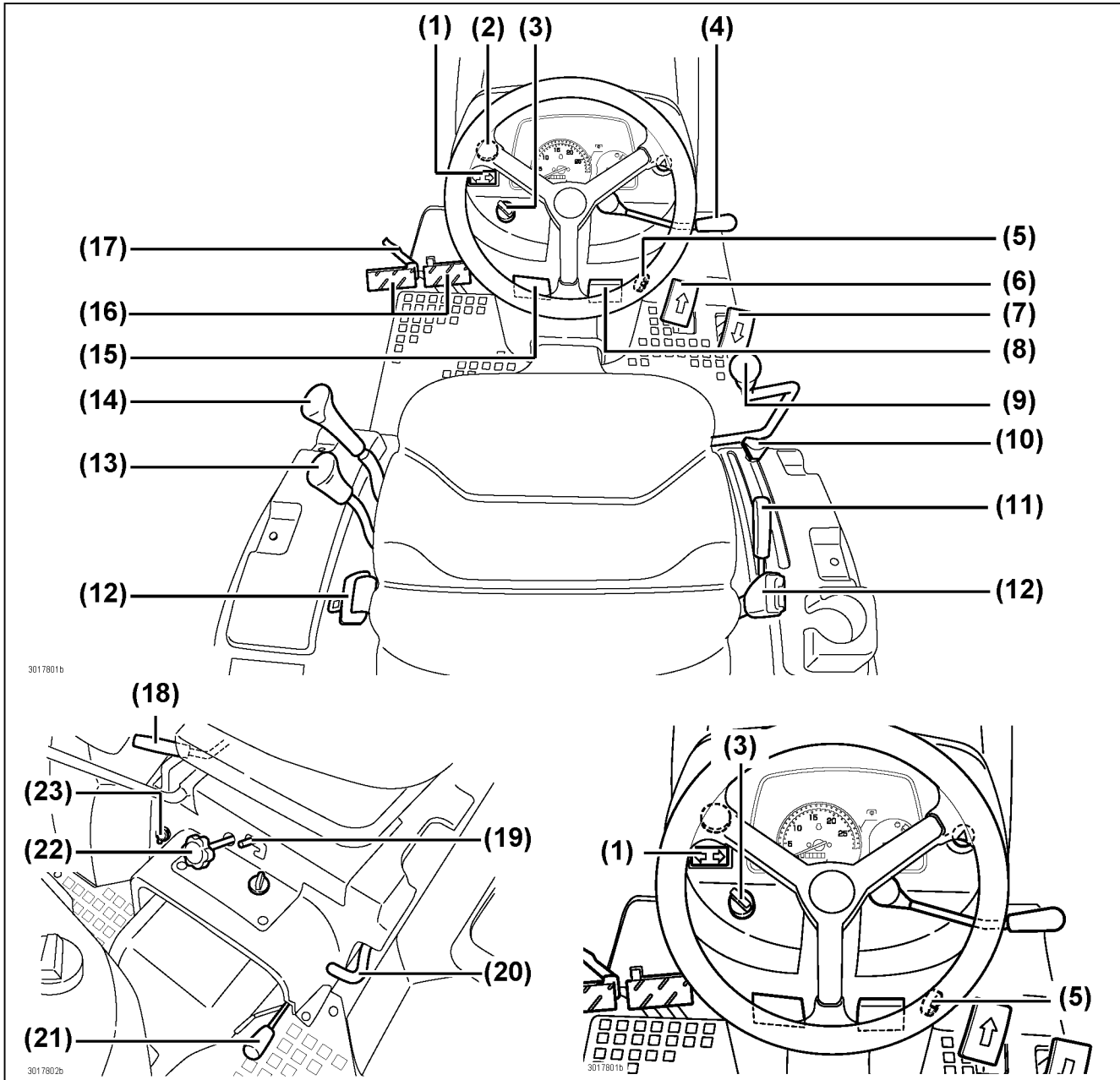

- (1) Turn signal switch
- (2) Power Take Off (PTO) switch
- (3) Headlights, side lights, hazard lights/rear working lights switch
- (4) Throttle control lever
- (5) Starter key switch
- (6) Forward drive pedal
- (7) Reverse drive pedal
- (8) Cruise control lever
- (9) Implement control lever
- (10) Position stop knob
- (11) 3-point hitch control lever

- (12) Retractable seatbelt
- (13) Mid-/Rear Power Take Off (PTO) select lever
- (14) Range gear lever
- (15) Parking brake lock lever
- (16) Brake pedals
- (17) Brake pedal connector lock
- (18) Operator seat forward and backward lever
- (19) Implement control lever lock
- (20) Differential lock pedal
- (21) 2WD/4WD lever
- (22) Hydraulic flow control/stop knob
- (23) 12V DC outlet

■ **Function of Components**

(1) Turn signal switch

Indicates when the corresponding turn signal lights is illuminated/flashing.

- (A) Turn signal switch*
- (B) Right turn signal light*
- (C) Left turn signal light*
- (a) Right turn signal light ON*
- (b) Left turn signal light ON*

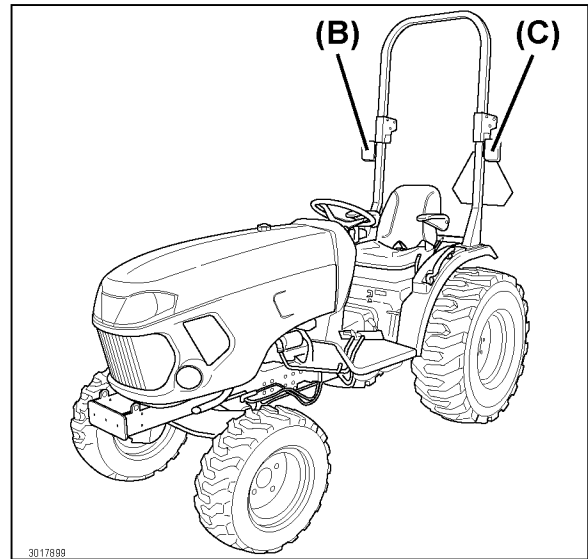
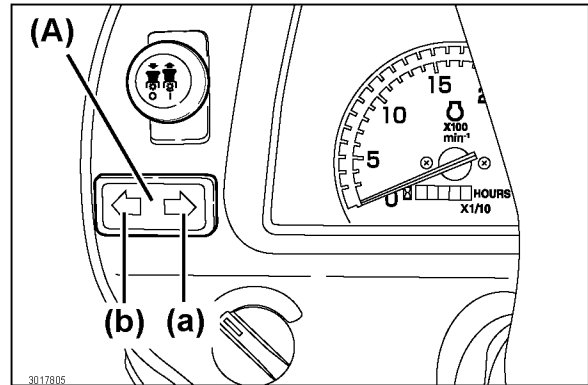

NOTE

- The turn signal switch only operates when the starter key switch is in the ON position.
- When a turn signal light switch is in the ON position and the hazard lights switch is in the ON position, the turn signal light overrides the hazard lights, i.e., the hazard lights are turned OFF. When the turn signal light switch is in the OFF position, the hazard lights illuminates/flashing.

(2) Power Take Off (PTO) switch

Turn ON or OFF the Power Take Off (PTO).

- (A) Power Take Off (PTO) switch*
- (a) ON position*
- (b) OFF position*

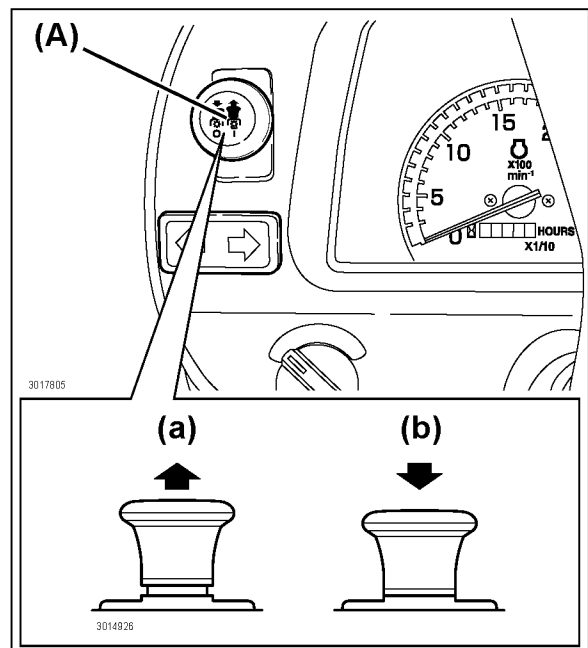

5. NAMES AND FUNCTIONS OF COMPONENTS

(3) Light control/hazard lights button switch

Illuminates the following lights:

- Headlights
- Tail lights
- Sidelights
- Hazard lights
- Rear worklights (option)

(A) Light control/hazard lights button switch

- (a) OFF position.
(b) Hazard lights are turned ON.
(c) Headlights, tail lights, sidelights and rear worklights (option) are turned ON.
(d) Headlights, tail lights, hazard lights, sidelights and rear worklights (option) are turned ON.

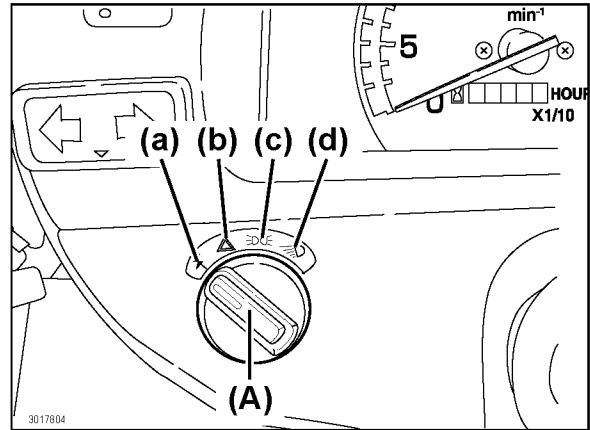

(4) Throttle control lever

Increases or decreases the engine speed (Revolutions Per Minute (rpm)) rate.

(A) Throttle control lever

- (a) Push forward to increase the engine speed (Revolutions Per Minute (rpm))
(b) Pull backward to decrease the engine speed (Revolutions Per Minute (rpm))

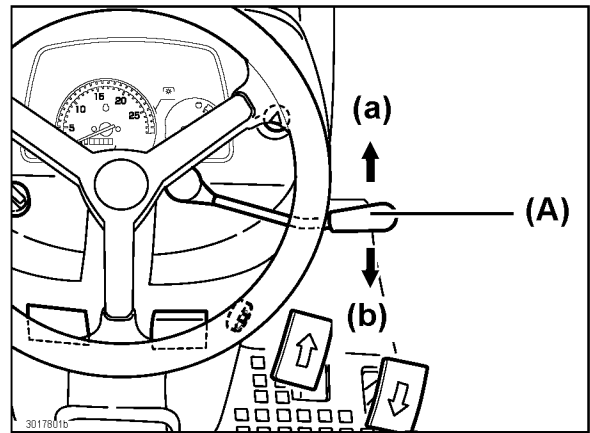

(5) Starter key switch

Start and/or shut off the engine.

(A) Starter key switch

- (a) OFF position:
The engine does not run.
(b) ON position:
The engine oil pressure warning light, the alternator/battery charging light and the glow plugs indicator light illuminates.
(c) START Position:
The starter turns the flywheel to run the engine. The engine begins to run. Once the engine is running, release the starter key switch.

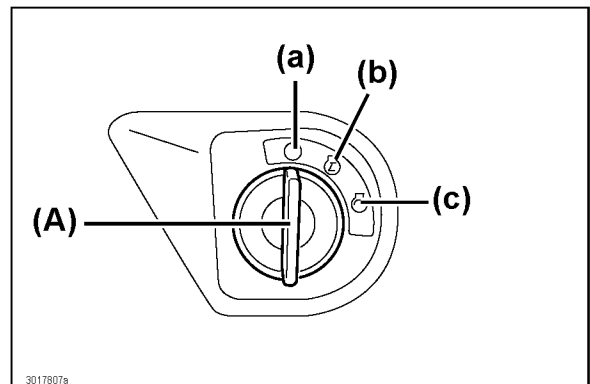

5. NAMES AND FUNCTIONS OF COMPONENTS

(6) Forward and reverse drive pedals

The tractor accelerated speed depends on how far the forward drive pedal or the reverse drive pedal is depressed.

(A) Forward drive pedal

To move forward: depress the forward drive pedal.

(B) Reverse drive pedal

To move backward: depress the reverse drive pedal.

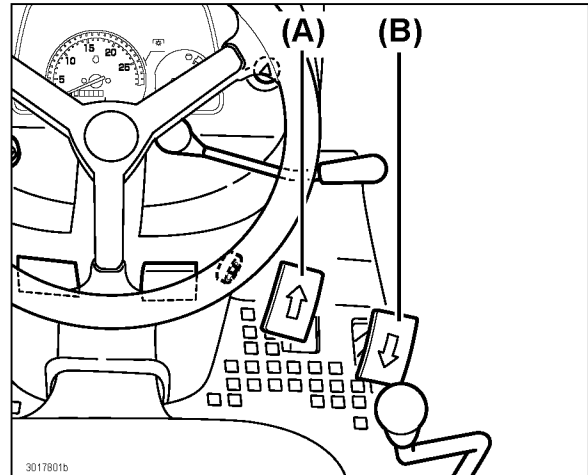

(7) Cruise control lever

The cruise control regulates forward speed of the tractor at a preset speed.

(A) Cruise control lever

(a) Engaged position

(b) Disengaged position

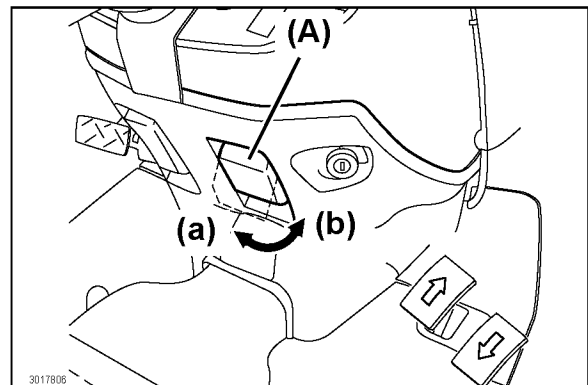

(8) Implement control lever

Control the loader.

(A) Implement control lever

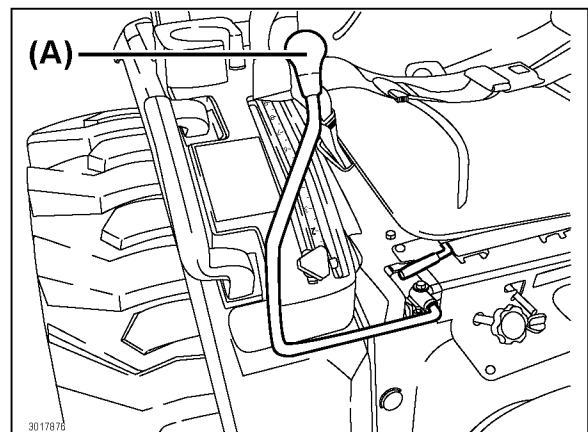

5. NAMES AND FUNCTIONS OF COMPONENTS

(9) Position stop knob

Hold the 3-point hitch control lever to a specific position.

(A) Position stop knob

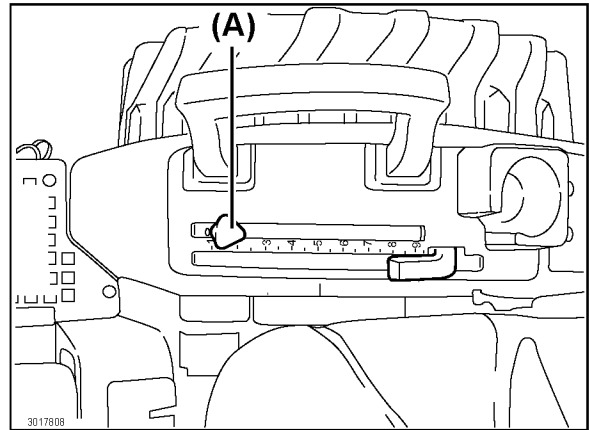

(10) 3-point hitch control lever

Control the height of the lower links.

(A) 3-point hitch control lever

(a) Backward position: raises the implement.

(b) Forward position: lowers the implement.

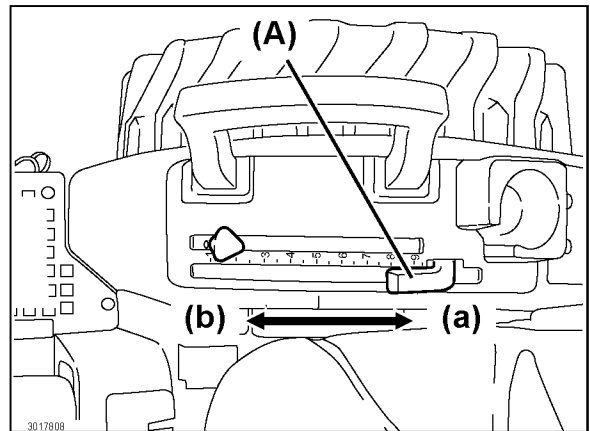

(11) Retractable seatbelt

Keep the operator safe while operating the tractor.

(A) Retractable seatbelt

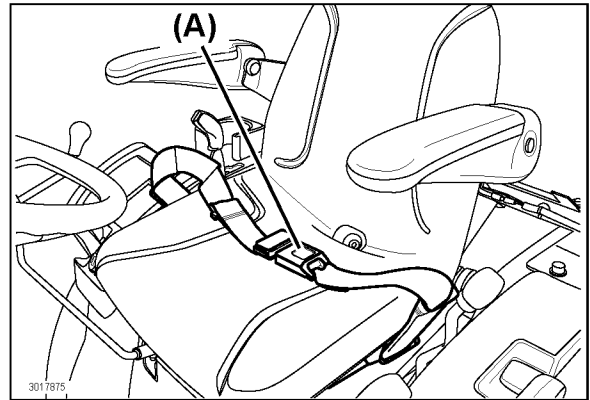

5. NAMES AND FUNCTIONS OF COMPONENTS

(12) Mid-/Rear Power Take Off (PTO) select lever

Select the Mid- or Rear Power Take Off (PTO) depending on the implement in used.

(A) Mid-/Rear Power Take Off (PTO) select lever

- (a) Operating the Rear Power Take Off (PTO) only
- (b) Operating the Mid-Power Take Off (PTO) and the Rear Power Take Off (PTO) simultaneously
- (c) Operating the Mid-Power Take Off (PTO) only

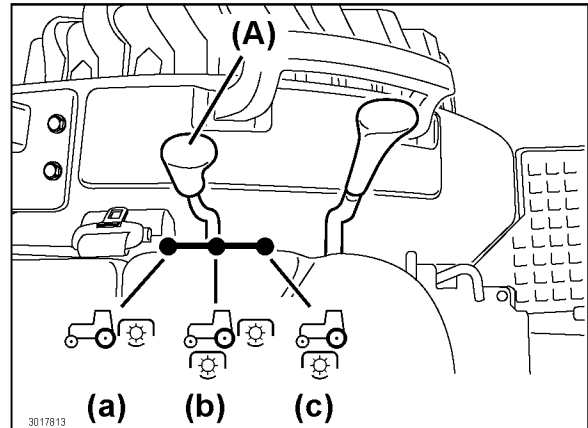

(13) Range gear lever

Change the range gear setting.

(A) Range gear lever

There are 3 positions:

L (Slow): Used for heavy load operation. Low traveling speed.

N (neutral) position: Before starting the engine, ensure that the range gear lever is in the N (neutral) position.

H (Fast): Used for light load operation. High traveling speed.

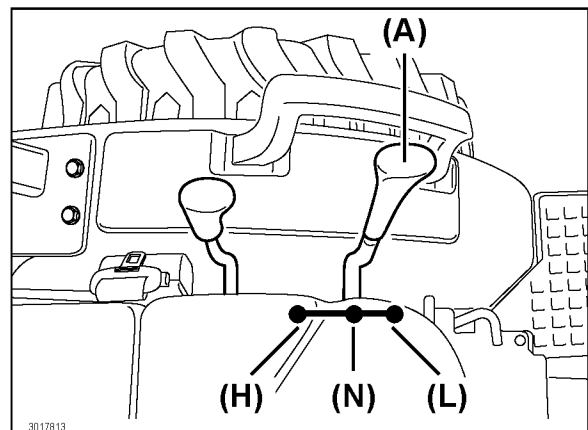

(14) Parking brake lock lever

Engage the parking brake.

(A) Parking brake lock lever

- (a) Lock
- (b) Unlock

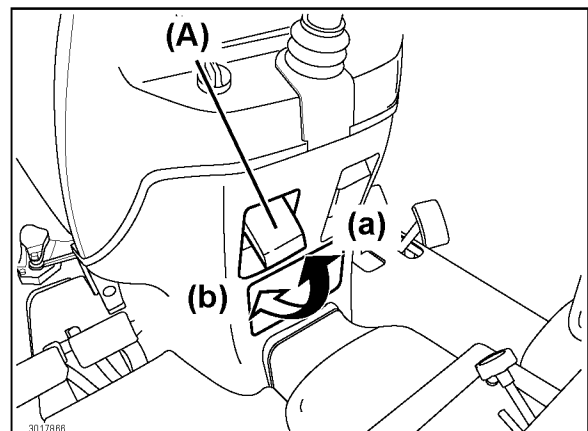

5. NAMES AND FUNCTIONS OF COMPONENTS

(15) Brake pedals

Reduce the speed and stop the tractor.

(A) Right brake pedal

The right brake pedal controls the rear right axle brake.

(B) Left brake pedal

The left brake pedal controls the rear left axle brake.

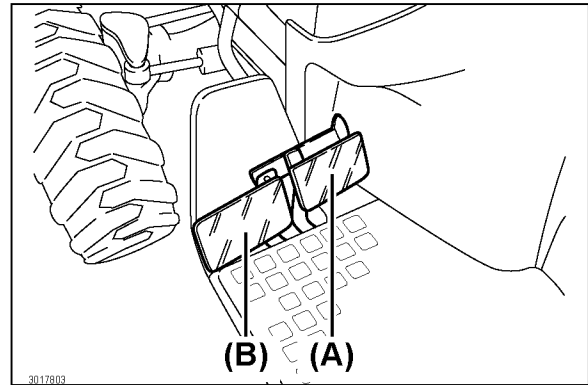

(16) Brake pedal connector lock

Locks the left and the right brake pedals together.

(A) Brake pedal connector lock

(a) Unlocked position

(b) Locked position

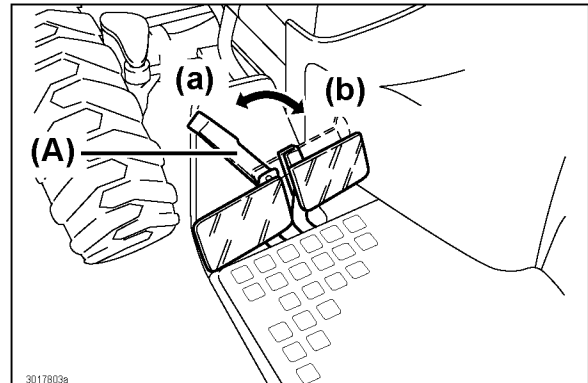

(17) Operator seat forward and backward lever

Adjust the operator seat to the forward or backward position.

(A) Operator seat forward and backward lever

(a) Toward the front

(b) Toward the rear

(c) Unlock

(d) Lock

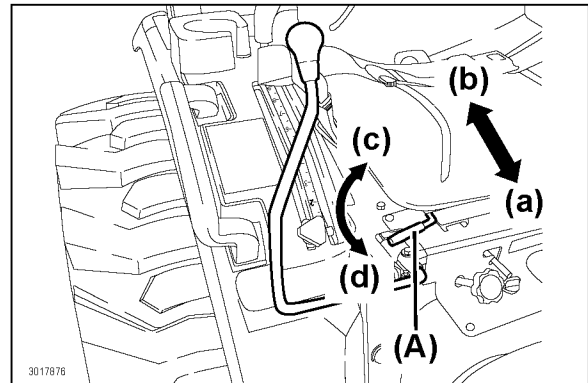

(18) Implement control lever lock

Lock the implement control lever to the N (neutral) position.

(A) Implement control lever lock

(a) Locked position

(b) Unlocked position

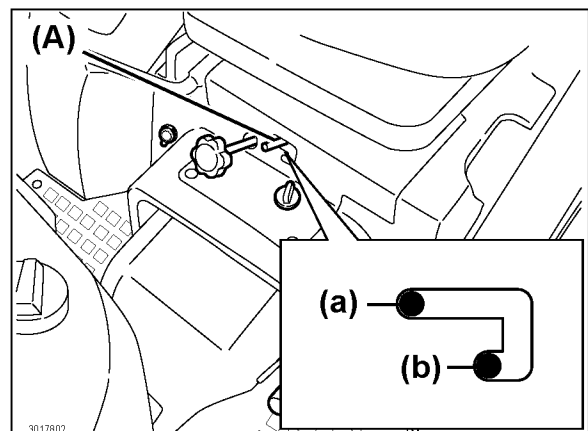

5. NAMES AND FUNCTIONS OF COMPONENTS

(19) Differential lock pedal

Engages or disengages the differential lock.

WARNING

- To prevent tipping of the tractor:
 - do not attempt to turn with the differential lock engaged
 - do not engage the differential lock while the tractor is traveling at a high speed

(A) Differential lock pedal

(a) Lock position

(b) Unlock position

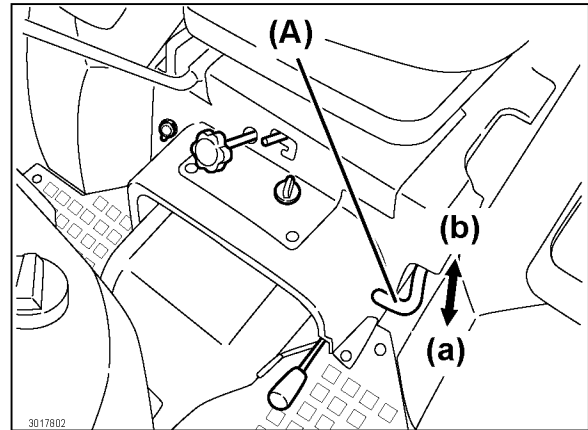

(20) 2WD/4WD lever

Engages or disengages the 4-wheel drive.

(A) 2WD/4WD lever

(a) Engage position

(b) Disengage position

WARNING

- Always disengage the 4-wheel drive during driving on a paved surface.
- Engage to the 4-wheel drive only as required to prevent premature wear on the front tires.

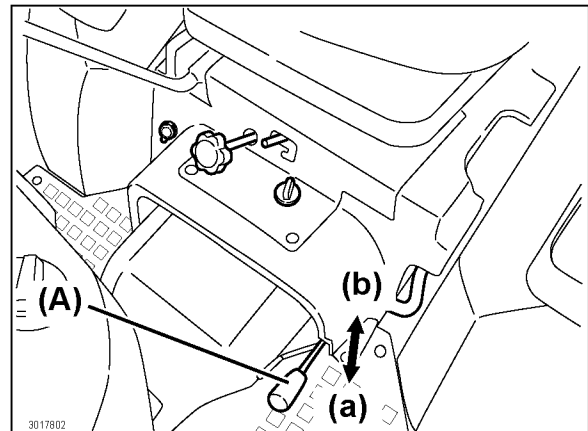

(21) Hydraulic flow control/stop knob

Increases/decreases and closes/opens the hydraulic circulation of the 3-point hitch.

(A) Hydraulic flow control/stop knob

(a) Open

(b) Close-stop

NOTE

- Do not fully close the hydraulic flow control/stop knob while traveling on the road.

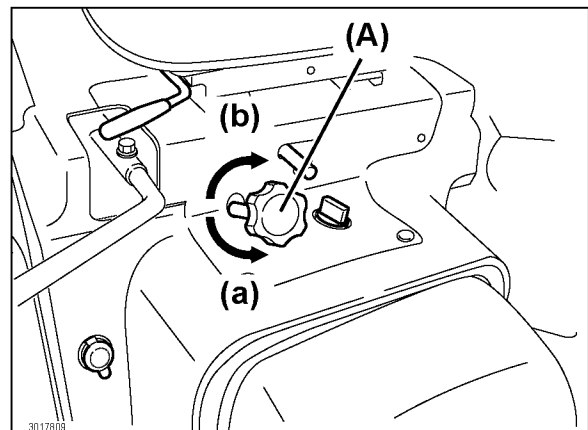

5. NAMES AND FUNCTIONS OF COMPONENTS

(22)12V DC outlet

Outlet used for 12V DC supply.

(A) 12V DC outlet

NOTE

- Avoid using the 12V DC outlet as cigarette lighter.

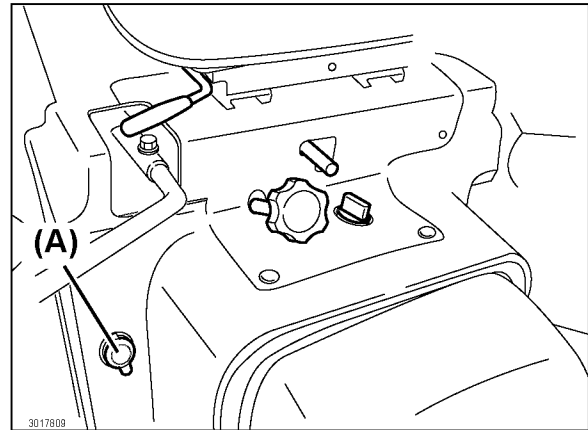

3. Instrument Panel

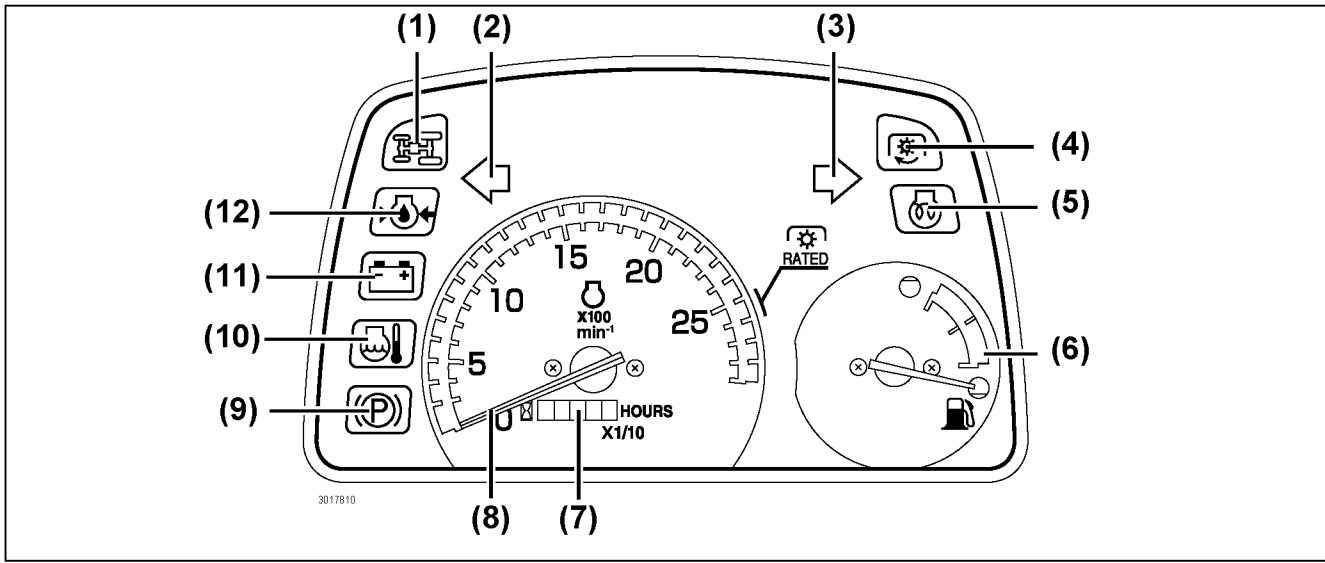

(1) 4-Wheel drive indicator light

The 4-wheel drive indicator light illuminates while the tractor is operated in the 4-wheel drive.

(2) Hazard lights/left turn signal indicator light

The hazard lights/left turn signal indicator light illuminates while the hazard lights and/or the left turn signal light is turned ON.

(3) Hazard lights/right turn signal indicator light

The hazard lights/right turn signal indicator light illuminates while the hazard lights and/or the right turn signal light is turned ON.

(4) Power Take Off (PTO) indicator light

Power Take Off (PTO) indicator light illuminates when Power Take Off (PTO) switch is in the ON position.

(5) Glow plug indicator light

The glow plug indicator light illuminates while the starter key switch is in the ON position and indicates that engine is being preheated. The light remains illuminated for approximately 20 seconds. Start the engine only after the glow plug indicator light turns OFF.

(6) Fuel gauge

Indicates how much fuel is in the fuel tank.

(7) Hour meter

Indicate the total accumulated operating hours.

(8) Tachometer

Indicates the current engine speed in increments of 100 Revolutions Per Minute (rpm).

NOTE

- The RATED mark on the tachometer indicates the appropriate engine speed to operate the Rear Power Take Off (PTO) shaft at the standard speed of 540 Revolutions Per Minute (rpm).

(9) Parking brake indicator light

Indicate parking brake is engaged.

NOTE

- In some cases, even when the parking brake lock lever appears to be in the "LOCKED" position, the parking brake itself may not be actually securely locked.

(10) Coolant temperature warning light

The light illuminates when the current coolant temperature in the engine is too high.

(11) Alternator/Battery charging light

Illuminates when:

- The starter key switch is in the ON position and the engine is not running.
- The alternator/battery charging circuit is out of order.

IMPORTANT

- While the engine is running, an illuminated alternator/battery charging light indicates the power generated by the alternator is too low.
 - fully push the throttle control lever forward
 - increase the engine speed
- If the light still remains illuminated:
 - immediately shut down the engine
 - contact YOUR LOCAL YANMAR TRACTOR DEALER for technical assistance

(12) Engine oil pressure warning light

The engine oil pressure warning light remains illuminated when:

- The starter key switch is in the ON position and the engine is not running.
- The engine oil pressure is abnormal.

IMPORTANT

- While the engine is running, an illuminated engine oil pressure warning light indicates the engine oil pressure is too low.
 - immediately shut down the engine
 - contact YOUR LOCAL YANMAR TRACTOR DEALER for technical assistance

6. PRE-OPERATION CHECK

1. Pre-Operation Check

1. Check the tractor for damage, excessive wear, cracks, missing parts, leaks, exposed wiring and any other problems.
2. Check the joints and connections for tight fit.
3. Make sure all the lights illuminate and function correctly.
4. Make sure all the safety alert decals are in correct positions.
5. Correct any problem detected.
6. Contact YOUR LOCAL YANMAR TRACTOR DEALER for problems that can not be solved.

Avoid operating the tractor when a problem has been indicated.

2. Precautions Before Operation

1. Always be aware of the performance limitations of the tractor.
2. Operate only within the limitations.
3. When operating the tractor, always maintain a "SAFETY FIRST!" approach.

3. Routine Checks

1. Check the safety features.
2. Check the tire air pressure.
3. Make sure the remaining diesel fuel is sufficient for the intended operation.
4. Check the engine oil level.
5. Check the transmission hydraulic oil level.
6. Check the coolant level.
7. Remove grass clippings and debris from the tractor.
8. Clean the air filter element.
9. Check any liquid leaks such as oil, coolant and fuel.
10. Check the radiator for possible blockage.
11. Check the retractable seatbelt for any problem/s.
12. Check Roll-Over Protective Structure (ROPS) for any problem/s.
13. Contact YOUR LOCAL YANMAR TRACTOR DEALER for technical assistance.

4. Prevent Damage to Plastic Surfaces and Painted Surfaces

1. To prevent scratches and discolorations on the surfaces:
 - Wipe the tractor only after thoroughly washing the surfaces.
2. Chemical substances such as pesticides can damage the plastic surfaces and painted surfaces.
 - Avoid spraying chemical substances on and near the tractor.
3. Avoid spilling diesel fuel onto the tractor.
 - Diesel fuel can damage the plastic surfaces and painted surfaces.
 - Immediately wipe off spilled diesel fuel.

7. OPERATE THE ENGINE

⚠ WARNING



Always run or idle the engine in a well ventilated area:

- To prevent serious illness or death, caused by the colorless and odorless carbon monoxide emitted by the engine.

- Always remain seated on the operator seat when:
 - starting the engine
 - operating the levers and controls
- Before starting the engine, always ensure:
 - the parking brake lock is engaged
 - release the forward and reverse drive pedals completely
 - range gear lever is in the N (neutral) position
 - Power Take Off (PTO) switch in the OFF position
- Always keep the retractable seatbelt fastened:
 - whenever the Roll-Over Protective Structure (ROPS) is in the unfolded "up" position and locked securely
- Start the engine only with the starter key switch.
 - avoid starting the engine by short circuiting across the starter solenoid terminals with a jumper wire
 - by bypassing the safety start switch
- Before operation, ensure all the safety features are functioning correctly. Make corrections as necessary.

1. Start the Engine

⚠ WARNING

- Always observe the following precautions when starting the engine.
 - before starting and during running the engine:
 - always drive the tractor outside or to a well ventilated area
 - to prevent serious illness or death caused by the carbon monoxide contained in the exhaust of the engine
- To prevent explosions, always use only diesel fuel to start the engine.
- In cold weather, use the Intake Air Heater System to help the engine start more smoothly.
- To prevent injury or death from a runaway tractor:
 - avoid starting the engine by short circuiting across the starter solenoid terminals with a jumper wire
 - the tractor starts in gear and begins to move when the normal circuitry is bypassed
- When starting the engine:
 - always remain seated on the operator seat with the transmission in the N (neutral) position
 - do not under any circumstances attempt to start the engine while the operator is still on the ground

NOTE

- When the temperature is below 40°F (5°C), for details, see "Start the Engine in Cold Weather" on page 7-7.

7. OPERATE THE ENGINE

1. Open/Close the Fuel Shut-Off Valve

1. To open the fuel shut-off valve: Turn the fuel shut-off valve to the ON (open) position.
2. To close the fuel shut-off valve: Turn the fuel shut-off valve to the OFF (closed) position.

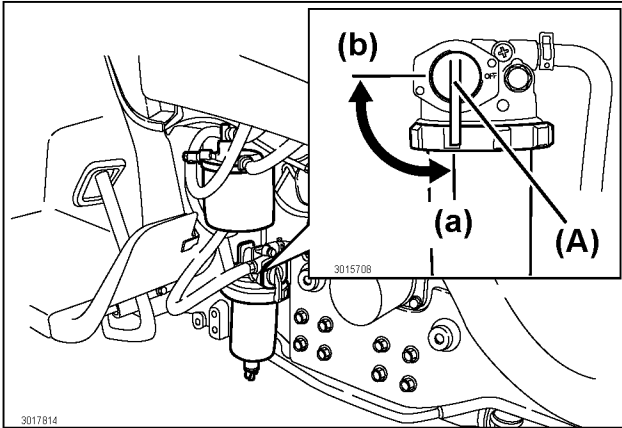

(A) Fuel shut-off valve
(a) ON (open) position
(b) OFF (closed) position

2. Get on the Tractor

1. Always use the step located on the left side of the tractor to climb on the tractor.
2. Sit on the operator seat.

3. Adjust the Operator Seat

1. Sit on the operator seat.
2. Operator seat forward and backward lever.
 - Move the operator seat forward and backward lever to set the optimal position.

NOTE

While sitting:

- Make sure the control levers and knobs can be comfortably operated.
- Readjust the operator seat position as necessary.

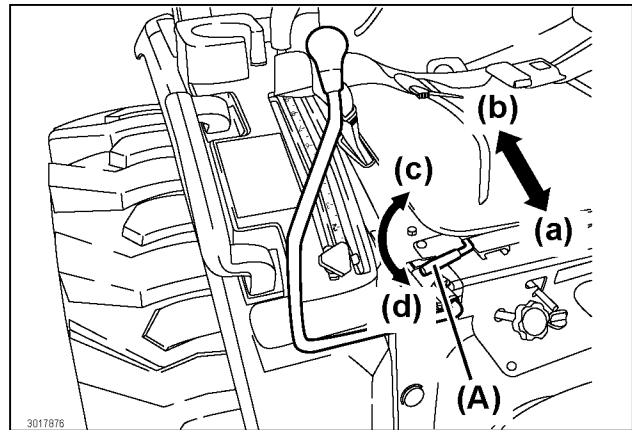

(A) Operator seat forward and backward lever
(a) Towards the front
(b) Towards the rear
(c) Unlock
(d) Lock

4. Fasten the Retractable Seatbelt

⚠ WARNING

- Always keep the retractable seatbelt fastened:
 - while operating the tractor with the Roll-Over Protective Structure (ROPS) in the unfolded "up" position
- The preceding action reduces the possibility of injury or death in the event of an accident such as an overturn or roll over.
- Do not under any circumstances use the retractable seatbelt when operating the tractor:
 - without the Roll-Over Protective Structure (ROPS)
 - with the Roll-Over Protective Structure (ROPS) in the folded "down" position

7. OPERATE THE ENGINE

1. Pull out the retractable seatbelt from the retracted position located on the right side of the operator seat.
2. Fasten the retractable seatbelt to the buckle located on the left side of the operator seat.

NOTE

- Do not twist the retractable seatbelt.

3. Adjust the retractable seatbelt to the suitable length.

NOTE

- Release the retractable seatbelt by pressing the retractable seatbelt quick release button.

CAUTION

- Hold the retractable seatbelt with the right hand when pressing the retractable seatbelt quick release button.
- The retractable seatbelt flies to the right which is highly dangerous.

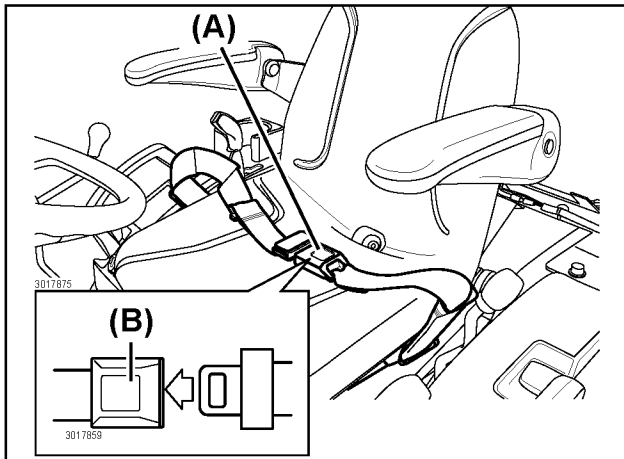

(A) Retractable seatbelt
(B) Buckle

5. Lock the Brake Pedals

1. Release the left and right brake pedals.
2. Move clockwise the brake pedal connector lock to lock together the left and right brake pedals.

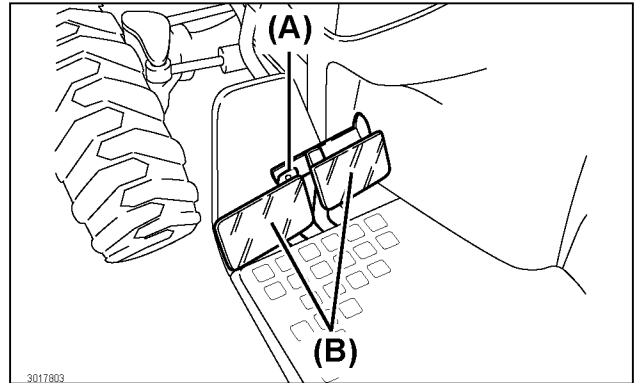

(A) Brake pedal connector lock
(B) Brake pedals

6. Lock and Set the Parking Brake

1. Use the brake pedal connector lock to connect the left and right brake pedals together.
2. Depress the brake pedals fully.
3. While depressing the brake pedals fully, pull up the parking brake lock lever securely.
4. Remove the foot from the brake pedals.
5. Make sure the parking brake is securely locked.

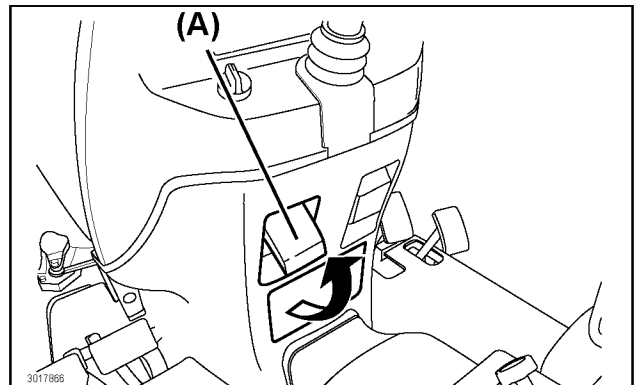

(A) Parking brake lock lever

7. OPERATE THE ENGINE

7. Perform the Rest of the Operations

1. Move the range gear lever to the N (neutral) position.

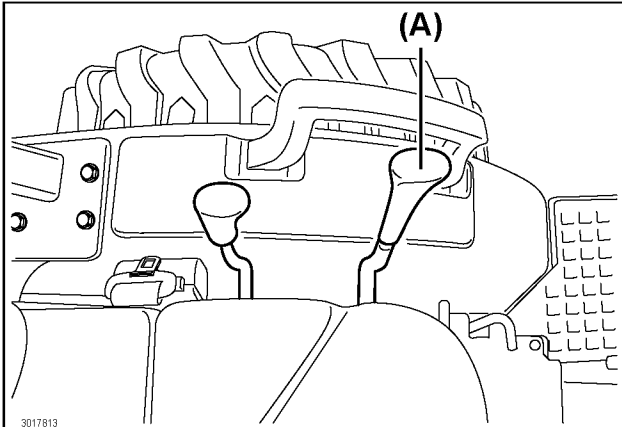

(A) Range gear lever

2. Release the forward and reverse drive pedals completely.

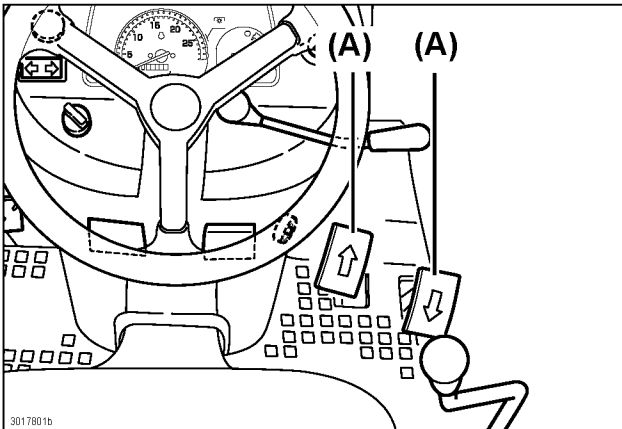

(A) Forward drive pedal
(B) Reverse drive pedal

3. Push down Power Take Off (PTO) switch to OFF position.

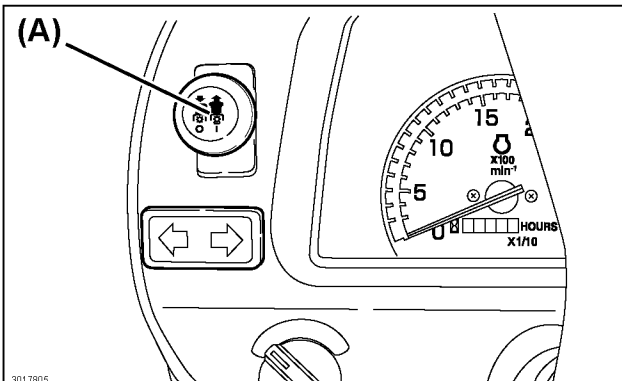

(A) Power Take Off (PTO) switch

4. Push the 3-point hitch control lever forward to lower any attached implements to the ground.

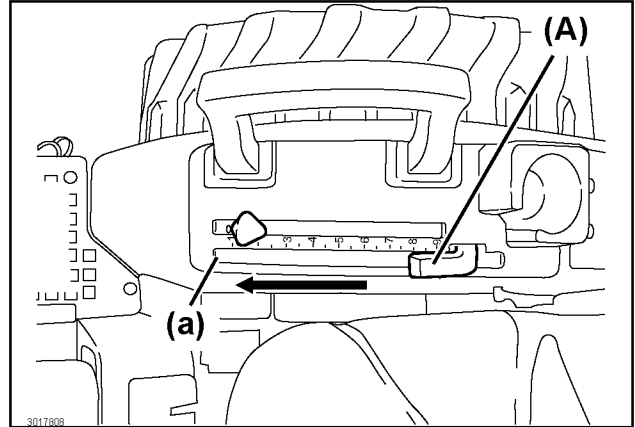

(A) 3-point hitch control lever
(a) Lowest position

5. Use the implement control lever to lower any attached implements to the ground.

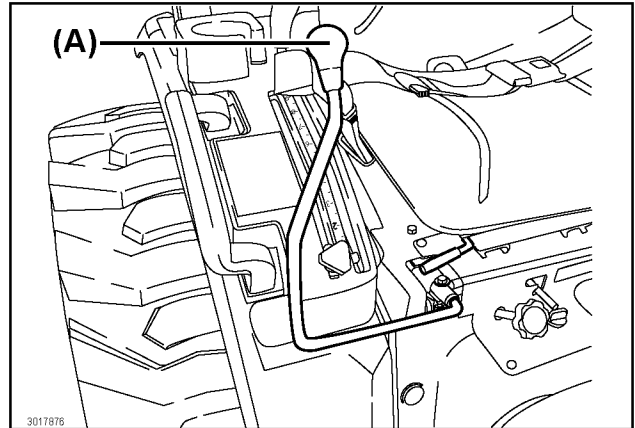

(A) Implement control lever

6. The preceding action prevents the tractor from suddenly rearing up during the starting of the engine.

7. OPERATE THE ENGINE

7. Push the throttle control lever forward from the slow idle position to the 1/3 to 1/2 fast positions.

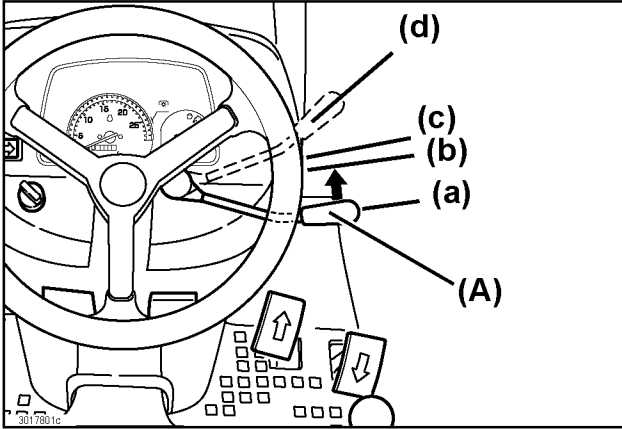

(A) Throttle control lever

(a) Slow idle position

(b) 1/3 fast position

(c) 1/2 fast position

(d) Fast idle position

8. Insert the Key into the Starter Key Switch and Turn the Key to the ON Position

OFF position:

The engine does not run.

ON position:

The engine oil pressure warning light and the alternator/battery charging light illuminates.

The glow plugs indicator light illuminates for 20 seconds.

START position:

- The starter turns the flywheel to run the engine.
- The preceding action quickly starts the engine.
- The engine begins to run.
- Once the engine is running, release the starter key switch.

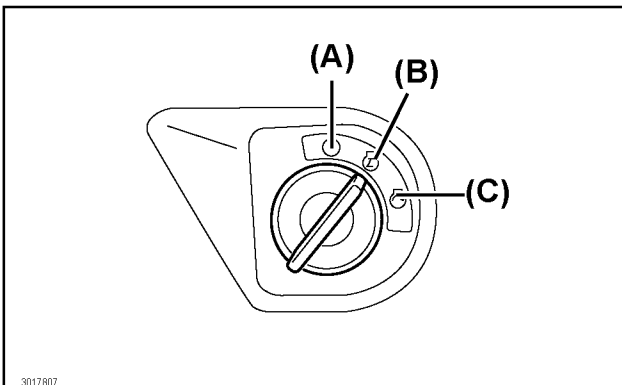

(A) OFF Position

(B) ON Position

(C) START Position

NOTE

- Start the engine after the glow plug indicator light has turned OFF.

9. Check the Lights on the Instrument Panel

After the key is turned to the ON position:

- The parking brake indicator light turns ON if the parking brake is engaged.
- The engine oil pressure warning light turns ON.
- The alternator/battery charging light turns ON.
- The glow plug indicator light turns ON.

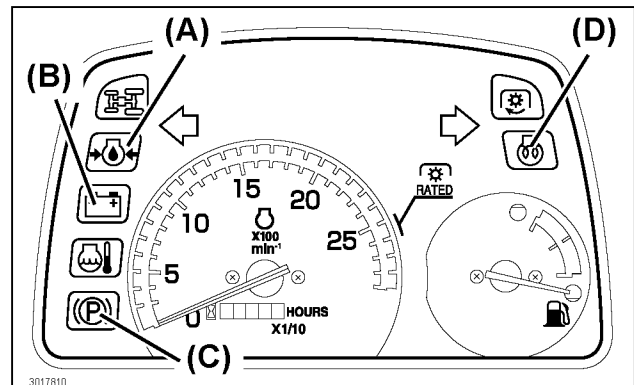

(A) Engine oil pressure warning light

(B) Alternator/battery charging light

(C) Parking brake indicator light

(D) Glow plug indicator light

NOTE

- The engine oil pressure light turns OFF within 5 seconds after the engine has started.
- The alternator/battery charging light turns OFF within 10 seconds after the engine is started.

IMPORTANT

- If the engine oil pressure light fails to turn OFF within 5 seconds after the engine is started:
 - shut off the engine and check for the cause.
- If no specific cause is detected, but a problem still persists:
 - contact YOUR LOCAL YANMAR TRACTOR DEALER for technical assistance

1. Turn the starter key switch to the ON position.
2. Energize the glow plug for 20 seconds to allow easy starting of the engine.
3. The glow plug indicator light is turned OFF after 20 seconds.
4. Turn and hold the key to the START position.

7. OPERATE THE ENGINE

- After the engine has successfully started, release the key.

NOTE

- If the key is released before the engine started:
 - wait until both the starter and engine stop rotating before trying to start the tractor again

IMPORTANT

- Continuous activation of the starter for more than 20 seconds can damage the starter.
- If the engine fails to start within 20 seconds, discontinue activating the starter.
- Wait for 2 minutes before trying to restart the engine.

- After the engine has started, warm up the engine for 5 minutes at 1200 to 1500 Revolutions Per Minute (rpm) without any load.

10. Warm Up the Engine in Cold Weather

- Insert the key to the starter key switch.
- Turn the key to the ON position.
- Wait for 20 seconds.
- After the glow plug indicator light goes out, turn the key to the START position to start the engine.
- In cold weather, warm up the engine for longer than 5 minutes so the hydraulic system can operate at peak performance.
- Warm up for a period as specified in the table below.

Temperature (°F (°C))	Warming-up Time (min.)
Over 32 (0)	At least 5
32 to 14 (0 to -10)	5 to 10
14 to -4 (-10 to -20)	10 to 15
Below -4 (-20)	More than 15

NOTE

- The engine may run slightly louder and emit pale blue exhaust during warm up.
 - the preceding state is normal
 - the amount of pale blue exhaust varies depending on the ambient temperature
- Idling the engine for a long time wastes fuel and causes carbon accumulation in the engine.

11. Idle the Engine

NOTE

- Avoid idling the engine for a long time.
- Prolong idling wastes fuel and causes carbon to build up in the engine.

- Pull the throttle control lever backward to the slow idle (900 Revolutions Per Minute (rpm)) position.
- Engage the parking brake securely, for details see "6. Lock and Set the Parking Brake" on page 7-3.

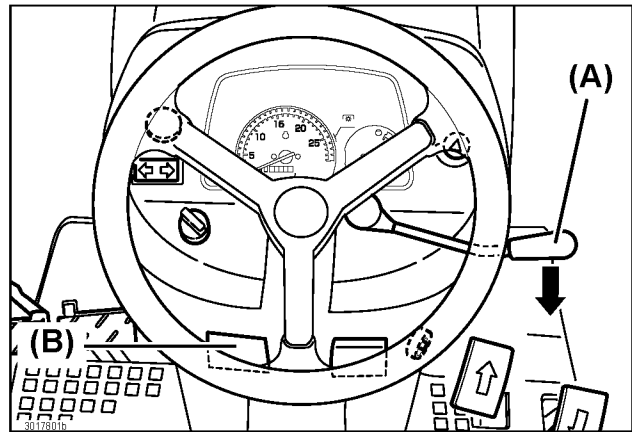

(A) Throttle control lever
(B) Parking brake lock lever

2. Start the Engine in Cold Weather

1. In case the tractor is operated at a temperature lower than 0°F (-18°C), the engine oil and/or transmission hydraulic oil heater can be installed in the tractor.
2. For information about the engine oil and/or transmission hydraulic oil heater, contact YOUR LOCAL YANMAR TRACTOR DEALER.
3. Turn the starter key switch to ON position.
4. Wait for 20 seconds.
5. After the glow plug indicator light goes out, start the engine.

3. Shut Off the Engine

1. Shut off the engine by:
 - Release the forward and reverse drive pedals completely.
 - Depress both brake pedals.

NOTE

- Make sure the brake pedals are connected together.

WARNING

- Always depress the brake pedals fully.

2. Move the range gear lever to the N (neutral) position.

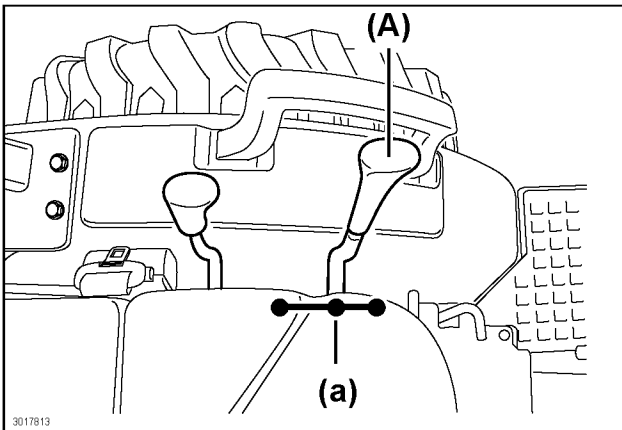

(A) Range gear lever
(a) N (neutral) position

3. Push down Power Take Off (PTO) switch to (OFF) position.

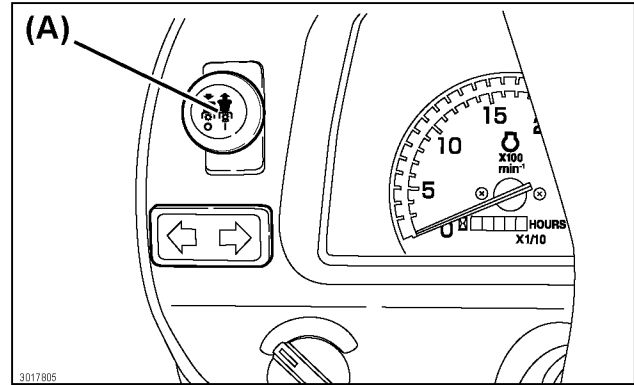

(A) Power Take Off (PTO) switch

4. Push the 3-point hitch control lever forward to lower any implements to the ground.

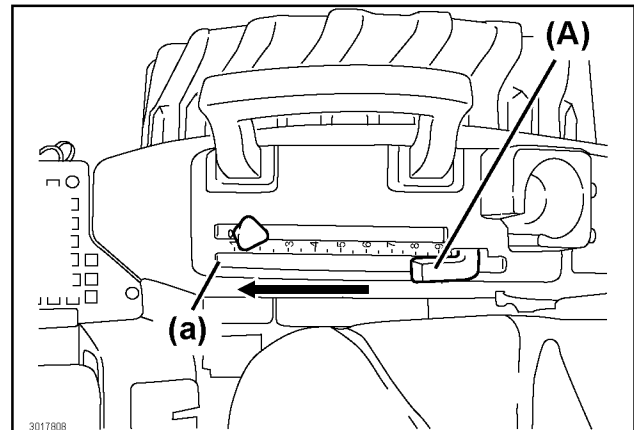

(A) 3-point hitch control lever
(a) Lowest position

NOTE

- Use the implement control lever to lower any implements to the ground.

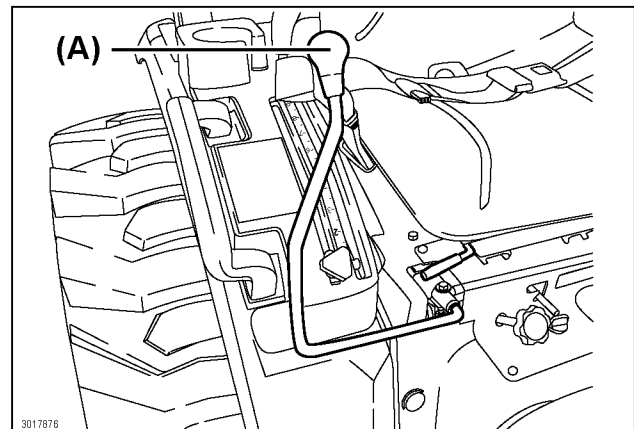

(A) Implement control lever

7. OPERATE THE ENGINE

- Engage the parking brake securely, for details, see "6. Lock and Set the Parking Brake" on page 7-3.
- Pull the throttle control lever backward to the slow idle position.

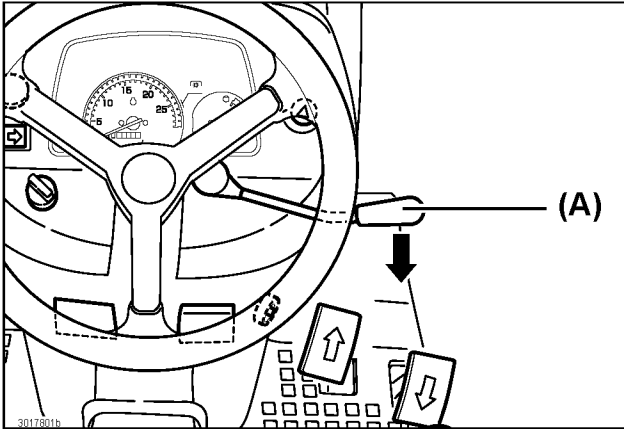

(A) Throttle control lever

- Idle the engine at least 2 minutes.
- Turn the starter key switch to the OFF position.
- Remove the key from the starter key switch.

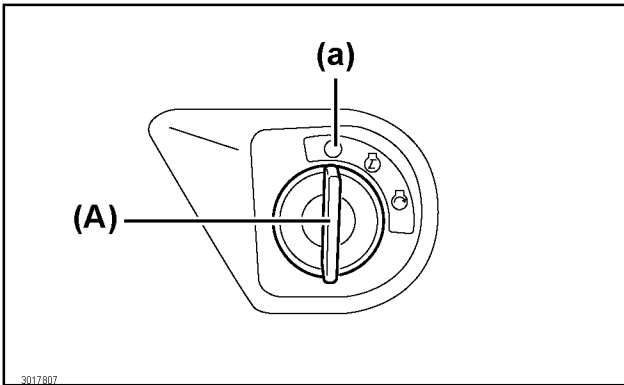

(A) Starter key switch
(a) OFF position

- Before leaving the operator seat, ensure the engine and all moving parts have stopped.

4. Restart a Stalled Engine

IMPORTANT

- If the engine stalls while operating under load, immediately restart the engine to prevent abnormal heat build up.

- Release the forward and reverse drive pedals completely.
- Move the range gear lever to the N (neutral) position.
- Operator must be properly seated on the operator seat.
- Push down Power Take Off (PTO) switch to OFF position.
- Start the engine.
- Continue with normal operation.
- Set the engine to idle speed for 1 or 2 minutes before stopping.

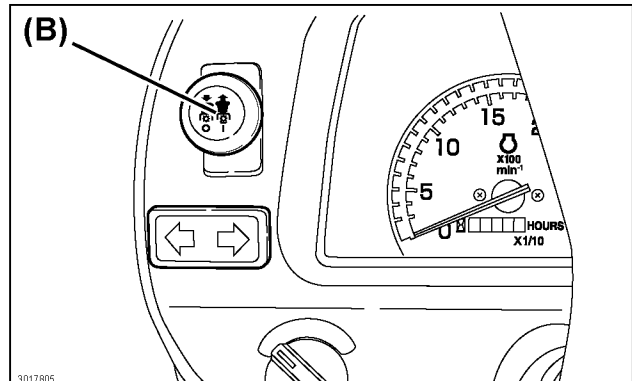
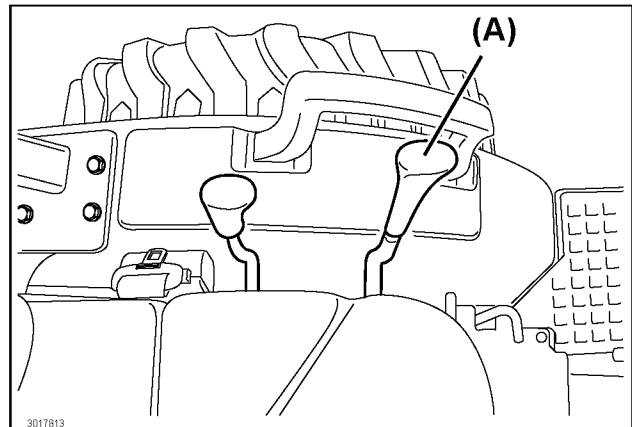

(A) Range gear lever
(B) Power Take Off (PTO) switch

5. Start When the Engine Runs Out of Fuel

NOTE

- The tractor has a self bleeding fuel system.
- Bleeding is automatically performed while the key is turned to the ON position.

1. Check the fuel tank. Add fuel as necessary.
2. Make sure the fuel filter is still functioning.
3. Make sure the fuel shut-off valve is in the ON (open) position.
4. The fuel is visible in the sediment bowl because the fuel is gravity fed into the fuel filter.

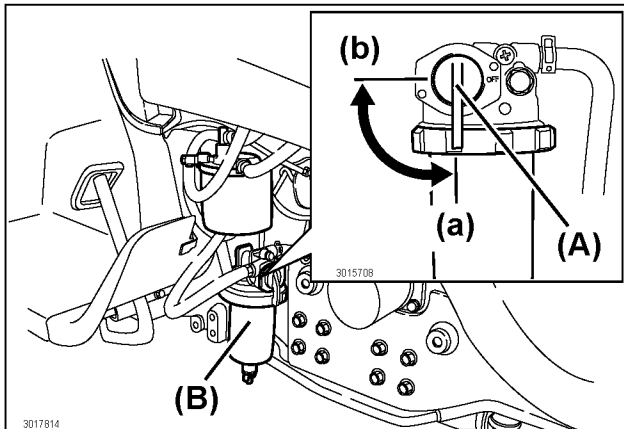

(A) Fuel shut-off valve

(B) Sediment bowl

(a) ON (open) position

(b) OFF (closed) position

IMPORTANT

- Continuous activation of the starter for more than 20 seconds can damage the starter.
- If the engine fails to start within 20 seconds, discontinue activating the starter.
- Wait for 2 minutes before trying to restart the engine.

5. Crank the engine for a maximum of 20 seconds.
6. If the engine fails to start within 20 seconds, stop cranking.
7. Wait at least 2 minutes before cranking again.

8. OPERATE THE TRACTOR

WARNING

Always use the drawbar to tow an implement.

- Do not under any circumstances attach a load to the axle housing.

Always decrease the tractor speed before turning:

- During traveling on a rough terrain.
- Before stopping to prevent the tractor from overturning.

Do not attempt to turn tractor with the differential lock engaged.

- Attempting to turn the tractor while the differential lock is engaged can lead to the tractor overturning.

Stay clear of ditches, potholes, embankments and ponds.

- The tractor can more easily overturn or rollover in soft and wet ground.
- Before entering an area covered with tall grass, walk and inspect the area to detect any obstacles.
- Remove potentially dangerous obstacles before driving.

Always watch where the tractor is going.

- Be alert and exercise extra caution while driving towards an area.
- Where the next section is difficult to see, e.g., blind corners, row of trees, or any similar situations.

When two or more people are working in one area:

- Regularly communicate and watch each other.
- Make sure all persons and implements in the area do not impede or cause injury to each other.

Always ensure the tractor is at a complete stop before attempting to get on or off.

Accident Hazard

- A child does not understand the principles of danger, nor comprehend imminent dangers and is often attracted to and approach the tractor.
 - Do not under any circumstances assume a child remain where last seen.
-
- Always keep a child out of the work area. Make sure a responsible person, other than the operator carefully supervising the child.
-
- If any child enters the current work area, immediately stop the tractor.
-
- Do not under any circumstances allow a child to ride on the moving tractor. The child can tamper with the controls, fall off and be run over by the tractor.
-
- Do not under any circumstances allow a child to operate the tractor.
-
- Do not under any circumstances allow a child to play on the tractor or implements.
-
- Be extremely careful when backing the tractor. Before and during backing, constantly look backward, sideways and downward to ensure no child is behind the tractor.

1. Operate a New Tractor

The service life of the tractor is determined by how well the tractor is operated and maintained.

Prior to delivery, the tractor has been fully tested to ensure that the tractor is operating normally. The manner the tractor is operated during the breaking-in period greatly affects the effective life of the tractor.

To bring about optimal tractor performance and to achieve the longest tractor life, various parts of the tractor have to be properly broken-in.

The following practices must be observed.

- Operate the tractor at low speeds for the first 50 operating hours.
- Avoid heavy operations and loads.
- Strictly observe the following instructions explained below.

■ Always run the tractor at less than full speed during the first 50 hours of operation

- Always start and brake the tractor slowly.
- In cold weather, always fully warm up the engine before operating the tractor.
- Avoid under any circumstances running the engine at a speed higher than needed.
- On rough roads or terrains, drive at low speeds.

NOTE

- The preceding practices should also be adopted for all tractors regardless of age to prevent premature tractor breakages and accidents.

■ Change the lubricating oil for the new tractor

The quality of the lubricating oil in any new tractor is very important. Parts not fully broken-in may not yet perfectly fit with each other.

Small metal shavings can be created during operation of a new tractor. The shavings can lead to premature wear or damage to tractor parts.

Yanmar recommends changing the lubricating oil earlier than the standard oil change schedule.

For the recommended oil change schedule, for details, see "Chapter 13. MAINTENANCE" on page 13-1.

2. Raise and Lower the Roll-Over Protective Structure (ROPS)

WARNING

- Always operate the tractor with the Roll-Over Protective Structure (ROPS) in the unfolded "up" position.
 - unless folding the structure is absolutely necessary, e.g., during operation in a low clearance area
- Keep the retractable seatbelt fastened while operating the tractor with the Roll-Over Protective Structure (ROPS) in the unfolded "up" position.
 - the preceding practice reduces the possibility of injury or death in the event of a roll over accident
- If the Roll-Over Protective Structure (ROPS) is not installed (taken off for some reason), always install the structure before operating the tractor.
- Always keep the Roll-Over Protective Structure (ROPS) on its original condition. An alteration can impair the protective capacity of the structure.
- Immediately replace a damaged Roll-Over Protective Structure (ROPS). Contact YOUR LOCAL YANMAR TRACTOR DEALER for technical assistance.
- Do not under any circumstances use the retractable seatbelt:
 - while the Roll-Over Protective Structure (ROPS) is in the folded "down" position
 - while the tractor does not have a Roll-Over Protective Structure (ROPS)

■ Lower (folded "down") the Roll-Over Protective Structure (ROPS)

The Roll-Over Protective Structure (ROPS) can be folded down only by approximately 82.40 degrees.

1. Pull out the hairpin clip from each of the insert pins located on both sides of the Roll-Over Protective Structure (ROPS).
2. Pull out the insert pins from both sides of the Roll-Over Protective Structure (ROPS).

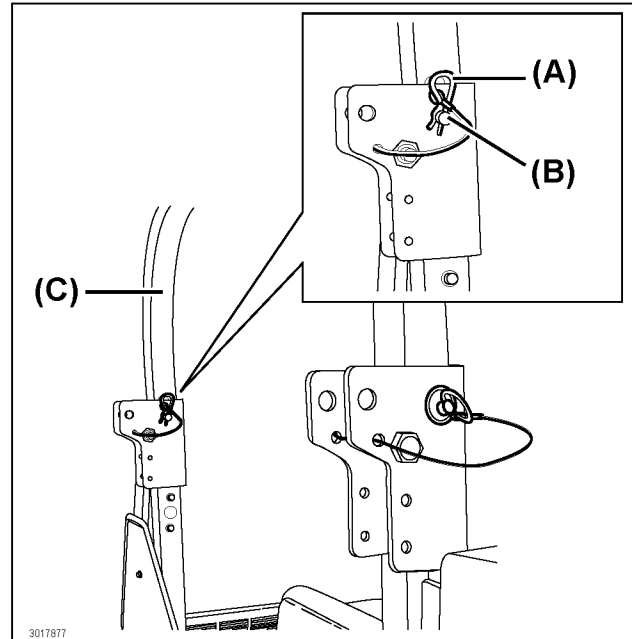

- (A) Hairpin clip
 (B) Insert pin
 (C) Top bar of the Roll-Over Protective Structure (ROPS)

8. OPERATE THE TRACTOR

3. Lower (folded "down") the Roll-Over Protective Structure (ROPS).
4. Retaining holes are located on both sides of the lowered Roll-Over Protective Structure (ROPS). Install the insert pins into the holes.
5. Hole is found at the end of the insert pin. Install the hairpin clip into the hole.
6. To secure the play-absorbing vibration-insulating rubber block, pull the upper bolt to the near side and insert the pins.

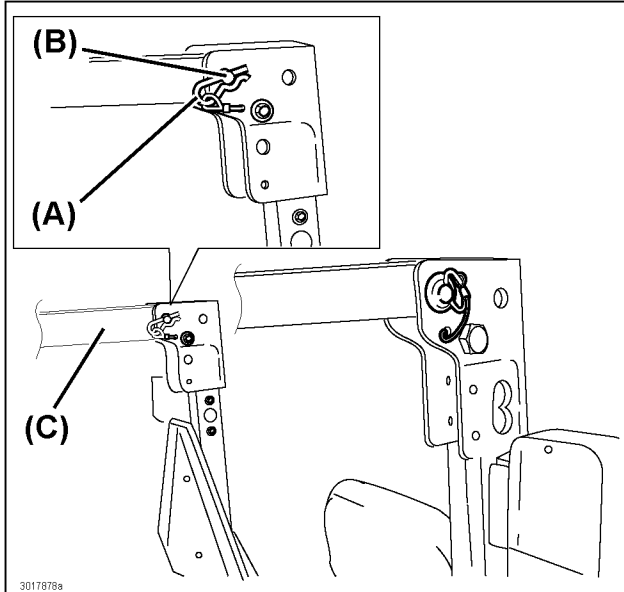

- (A) Hairpin clip
(B) Insert pin
(C) Top bar of the Roll-Over Protective Structure (ROPS)

■ Raise (unfolded "up") the Roll-Over Protective Structure (ROPS)

1. Pull out the hairpin clip from each of the insert pins located on both sides of the Roll-Over Protective Structure (ROPS).
2. Pull out the insert pins from both sides of the Roll-Over Protective Structure (ROPS).

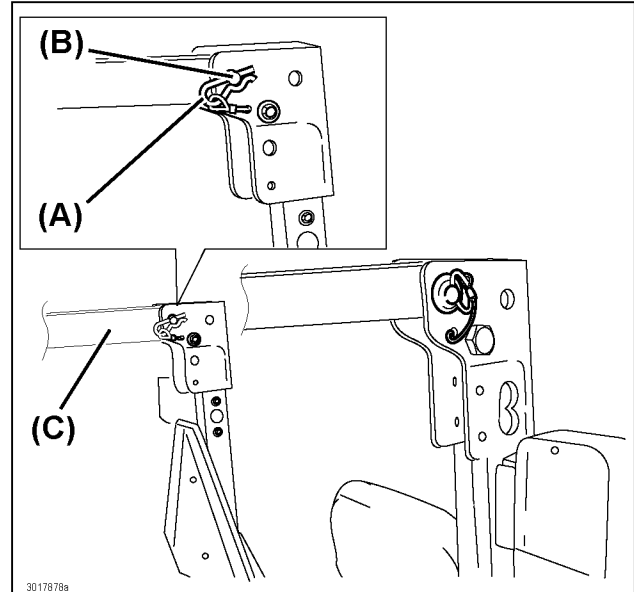

- (A) Hairpin clip
(B) Insert pin
(C) Top bar of the Roll-Over Protective Structure (ROPS)

3. Raise (unfolded "up") the Roll-Over Protective Structure (ROPS).
4. Retaining holes are located on both sides of the Roll-Over Protective Structure (ROPS) in the unfolded "up" position. Install the insert pins into the holes.
5. Insert pin jam hole is located at the end of the insert pin. Install the hairpin clip into the holes.
6. To secure the play-absorbing vibration-insulating rubber block, pull the upper bolt to the near side and insert the pins.

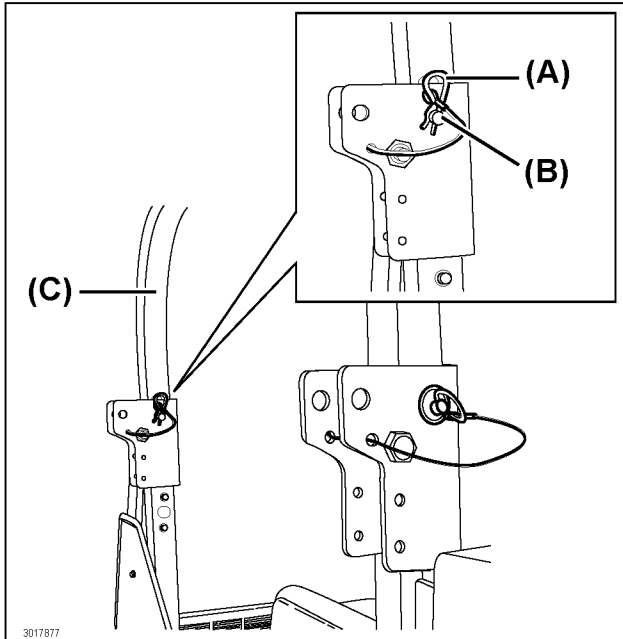

(A) Hairpin clip
 (B) Insert pin
 (C) Top bar of the Roll-Over Protective Structure (ROPS)

3. Operate the Tractor

⚠ WARNING

- Before starting or operating the tractor, always ensure there is no bystander or obstacle.
- Push down Power Take Off (PTO) switch to OFF position.
- Raise any implements.

IMPORTANT

- To prevent damage to the transmission, stop the tractor completely before operating the:
 - range gear lever
 - 2WD/4WD lever

1. Sit on the operator seat

Regarding how to adjust operator seat position, for details, see "3. Adjust the Operator Seat" on page 7-2.

Regarding how to fasten the retractable seatbelt, for details, see "4. Fasten the Retractable Seatbelt" on page 7-2.

2. Use the turn signal switch and light control/hazard lights switch

■ Turn Signals

NOTE

- The turn signal switch does not function when the starter key switch is in the OFF position.

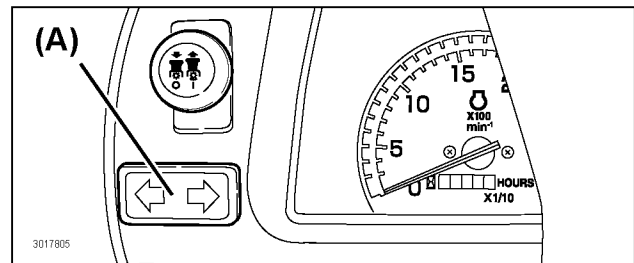

(A) Turn signal switch

1. Press either the right arrow or the left arrow to turn ON the right turn signal light or the left turn signal light.
2. To turn OFF the turn signal light,
 - Press to the first stop the opposite turn signal switch to the N (neutral) position.
 - Pressing beyond the first stop turns ON the opposite turn signal light.

Light Control/Hazard Lights Button Switch

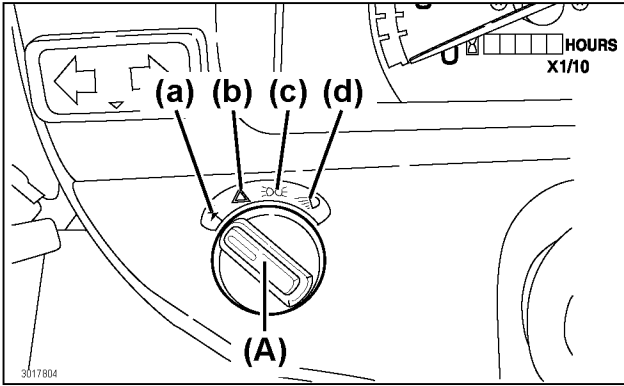

- (A) Light control/hazard lights button switch**
 (a) OFF position.
 (b) Hazard lights are turned ON.
 (c) Headlights, tail lights, sidelights and rear worklights (option) are turned ON.
 (d) Headlights, tail lights, hazard lights, sidelights and rear worklights (option) are turned ON.

3. Start the engine.

For details, see “Chapter 7. OPERATE THE ENGINE”.

Warm Up Transmission Hydraulic Oil in a Cold Weather Situation

⚠ WARNING

Before warming up the engine, ensure:

- The parking brake lock lever is locked.
- The range gear lever is in the N (neutral) position.
- Power Take Off (PTO) switch is in the OFF position.

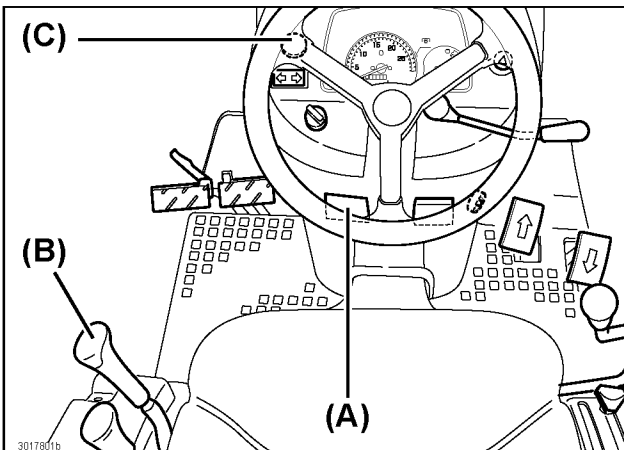

- (A) Parking brake lock lever**
(B) Range gear lever
(C) Power Take Off (PTO) switch

1. Warm up for 5 minutes after starting the engine.
2. Operate any implement on the tractor only after warming up the engine.
3. Using the implements while the engine is still cold (or not fully warmed up), problems such as seizure, breakage or premature wear can occur.
4. The engine oil is distributed through out the engine during warming up.
5. The transmission hydraulic oil also functions as the hydrostatic transmission (HST) oil.
6. In cold weather, the cold oil has a higher viscosity, making oil circulation sluggish.
 - The hydraulic pressure does not smoothly rise after engine start up.
 - The preceding action can cause a problem with the hydraulic system.
7. To prevent the preceding problem:
 - Pre-warm the engine at about 50% of the rated Revolutions Per Minute (rpm) for a period of time, as specified in the table below:

Ambient Temperature (°F (°C))	Required warm-up time (min.)
Over 14 (-10)	Approximately 5
5 to 14 (-15 to -10)	5 to 10
-4 to 5 (-20 to -15)	10 to 20
Lower than -4 (-20)	Longer than 20

IMPORTANT

- Warm up the engine of the tractor before operating any implements.

4. Select travel speed

1. The tractor may be operated in any gear at engine speeds between 1000 Revolutions Per Minute (rpm) and the RATED speed.
2. Within the preceding range, the engine can be subjected to a variety of load conditions.

■ Range Gear Lever

For details, see “(13) Range gear lever” on page 5-8.

IMPORTANT

To prevent transmission damage:

- Make sure the tractor has completely stopped before operating the range gear lever.
- Before reversing directions:
 - make sure the tractor has completely stopped
- Always move the range gear lever to the N (neutral) position before starting the engine.

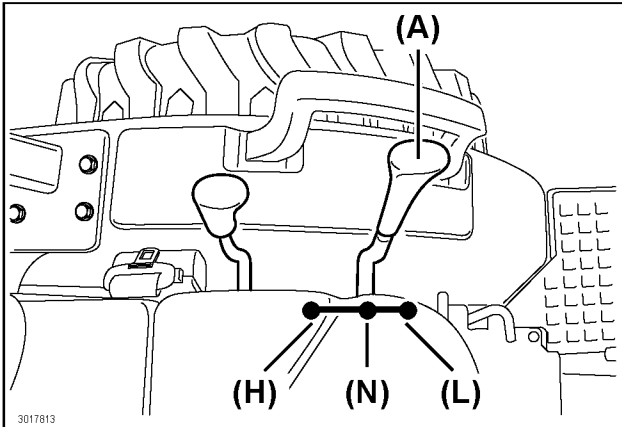

(A) Range gear lever

(L) Slow: Used for heavy load operation. Low traveling speed.

(N) N (neutral) position: Before starting the engine, ensure that the range gear lever is in the N (neutral) position.

(H) Fast: Used for light load operation. High traveling speed.

IMPORTANT

To prevent overloading the engine, always select the appropriate gear and engine speed for the job.

- Use a higher gear and lower engine speed for work involving a light load.
- Use a lower gear and higher engine speed for work involving a heavy load.

■ 2WD/4WD Lever

⚠ WARNING

- Always exercise extreme caution while operating the tractor on slopes.
- Enable the 4-wheel drive in order to increase traction as necessary.
- While the 4-wheel drive can improve access to terrain with dangerous slopes, the danger of tipping over is still present.

1. Engage the 4-wheel drive to improve braking on wet, icy, sloped or graveled surfaces.
2. To prevent skidding and loss of steering control, also add weight to the tractor and travel at reduced speeds.

IMPORTANT

- Always disengage the 4-wheel drive during driving on a paved surface.
- Engage to the 4-wheel drive only as required to prevent premature wear on the front tires.
- Avoid under any circumstances using tire chains on the tractor's front wheels, because the tire chains can be thrown against the tractor and cause damage.

3. Use the 2WD/4WD lever to operate the tractor in either the 2-wheel drive or 4-wheel drive.
4. To engage the 4-wheel drive, push down the 2WD/4WD lever.
 - The preceding action connects the mechanical front wheel drive axle to the power train.

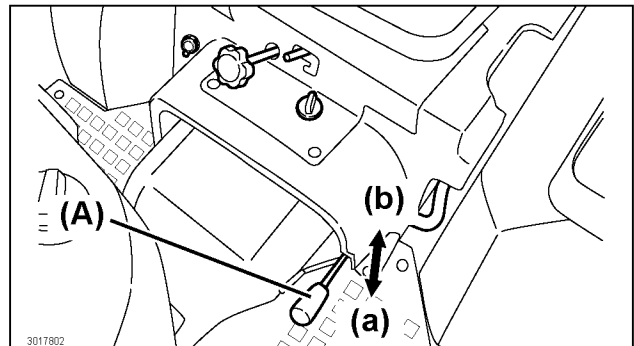

(A) 2WD/4WD lever

(a) 4WD position

(b) 2WD position

NOTE

- The 4-wheel drive and 2-wheel drive can be shifted while the tractor is in motion.
- The preceding action requires to reduce the traveling speed to allow smooth shifting and to avoid damage.
- Do not use the foot to move the 2WD/4WD lever.

Engage the 4-Wheel Drive

1. Before operating the 2WD/4WD lever:
 - Release slightly the forward and reverse drive pedal.
2. Push down the 2WD/4WD lever to engage the 4-wheel drive.
 - The 4-wheel drive indicator light illuminates.

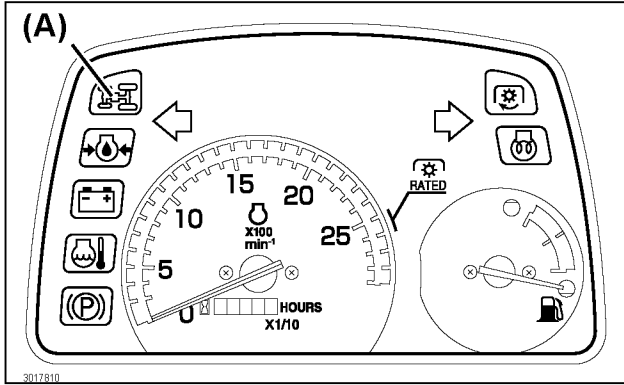

(A) 4-wheel drive indicator light

Disengage the 4-Wheel Drive

1. Before operating the 2WD/4WD lever:
 - Release slightly the forward and reverse drive pedal.
2. Pull up the 2WD/4WD lever to disengage the 4-wheel drive.
 - The 4-wheel drive indicator light turns OFF.

NOTE

- The load on the tractor may have to be reduced before changing from the 4-wheel drive to 2-wheel drive.

■ Tips on the 4-Wheel Drive

- To make sure proper performance under all types of working conditions, maintain the maximum acceptable tire air pressure in the front tires.
- Disengage the 4-wheel drive while transporting the tractor.
- Disengaging the 4-wheel drive increases the service life of the front tires.

5. Raise the implement

■ 3-Point Hitch Control Lever

- Pull the 3-point hitch control lever backward.
- Move any attached implements to the raised position.

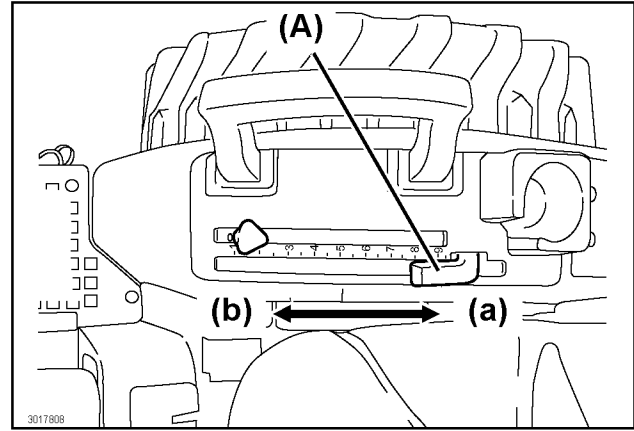

(A) 3-point hitch control lever

- (a) Raise
(b) Lower

NOTE

- Use the implement control lever to move any attached implements to the raised position.

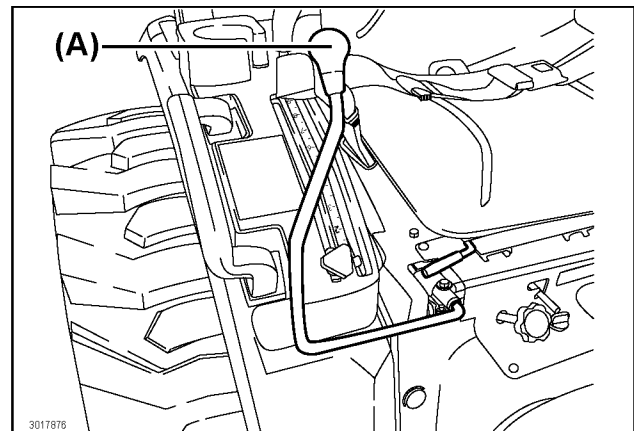

(A) Implement control lever

6. Disengage the Parking Brake

1. Depress both locked brake pedals.
2. Push all the way down the parking brake lock lever.
3. Release the locked brake pedals.

⚠ WARNING

- To prevent accidental tipping or overturning.
 - do not under any circumstances use unlocked brake pedals to stop the tractor at high speeds
- Move clockwise the brake pedal connector lock to lock together the left and right brake pedals when:
 - the brake pedals are not used for turning
 - traveling on roads
- Always slow down before making turns.

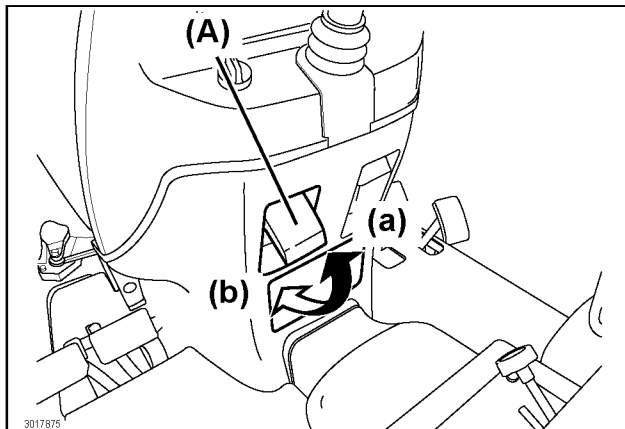
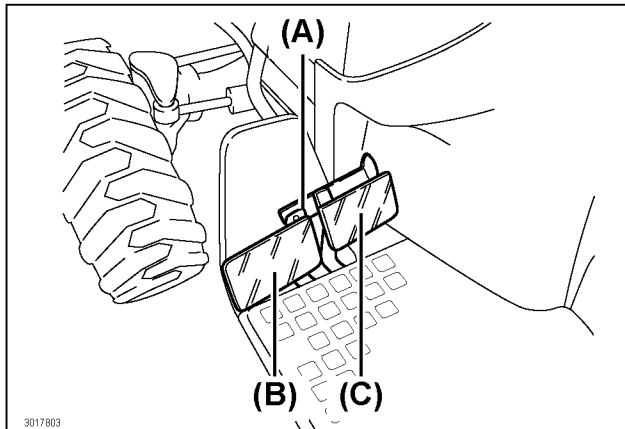

(A) Brake pedal connector lock
 (B) Left turn brake pedal
 (C) Right turn brake pedal
 (D) Parking brake lock lever
 (a) Lock
 (b) Unlock

7. Adjust the throttle control lever to reach the target speed

■ Throttle Control Lever

Use the throttle control lever to increase, decrease or maintain the current engine speed.

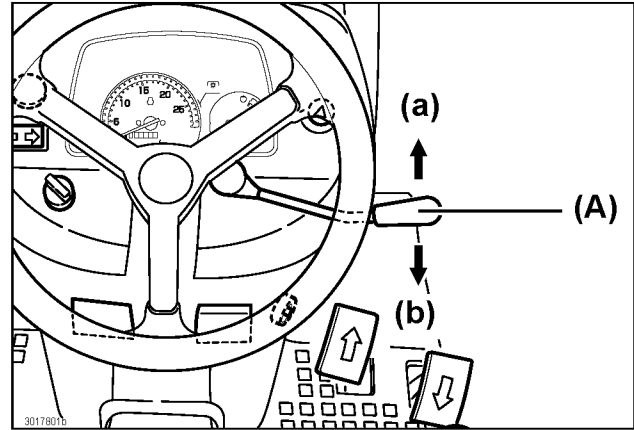

(A) Throttle control lever
 (a) Increase engine speed
 (b) Decrease engine speed

8. Slowly depress the forward or reverse drive pedal

■ Drive Pedals

The tractor accelerated speed depends on how far the forward drive pedal or the reverse drive pedal is depressed.

(A) To move forward: depress the forward drive pedal.

(B) To move backward: depress the reverse drive pedal.

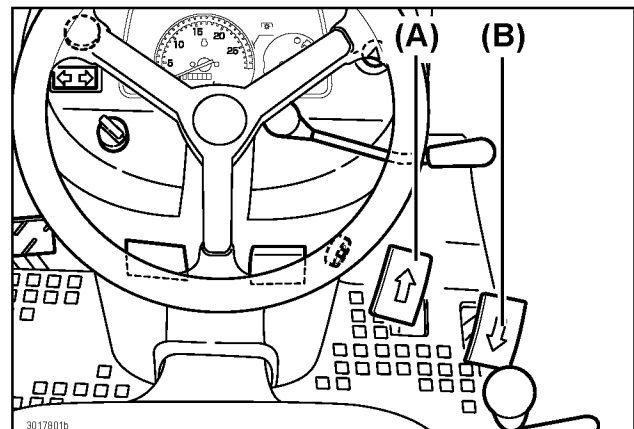

(A) Forward drive pedal
 (B) Reverse drive pedal

NOTE

- Make sure that the both brake pedals are connected using the brake pedal connector lock.
- Always slowly depress the drive pedals to avoid sudden jerking motion of the tractor.
- The preceding action can avoid damage to the power train, including hydrostatic transmission (HST) that can lead to an accident.
- Releasing the drive pedals to slow down the tractor.
- Simultaneously depress both brake pedals to make a complete stop.

9. Use the cruise control

The cruise control regulates forward speed of the tractor at a preset speed.

NOTE

- The cruise control can be operated only on the forward direction.

⚠ WARNING

Avoid injury!

- Use the cruise control only when traveling in a vast open area.
- Turn OFF cruise control before turning or when traveling on areas with many obstacles.

■ Engage the Cruise Control

1. Depress the forward drive pedal until the desired speed is reached.
2. Pull up the cruise control lever to locked position.
3. Release the forward drive pedal.
4. Release the cruise control lever.

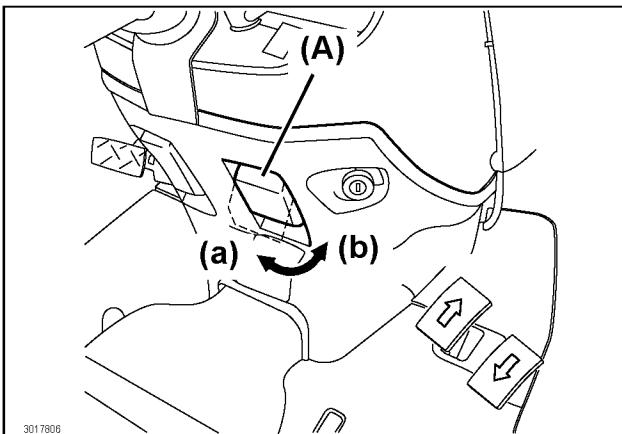

(A) Cruise control lever

(a) Engaged position

(b) Disengaged position

■ Disengage the Cruise Control

1. Depress the forward drive pedal to disengage the cruise control lever.
2. Release the forward drive pedal.
3. Depress the forward drive pedal again to check whether the cruise control lever is disengaged.

NOTE

- The cruise control lever is disengaged when the brake pedals is depressed.
- If the cruise control lever does not disengage, step on the brake pedals several times.
- The cruise control can also be disengaged when the forward drive pedal is depressed.
- Depressing the reverse drive pedal does not disengage the cruise control lever.
- Do not depress the reverse drive pedal when the cruise control lever is locked.

4. Stop the Tractor

■ Stopping Procedure

1. Make sure both brake pedals are securely connected using the brake pedal connector lock (B).
2. Push down Power Take Off (PTO) switch (F) to OFF position.
3. Slow down the engine.
4. Release the forward drive pedal (D) or the reverse drive pedal (E) completely.
5. Depress both brake pedals (A) to stop the tractor.

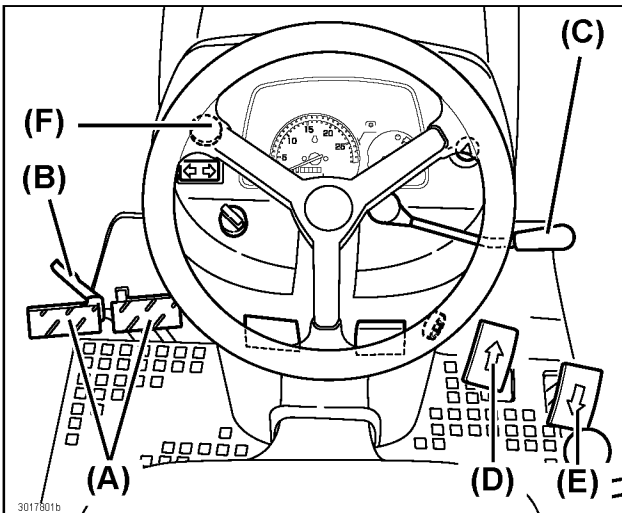

- (A) Brake pedals
 (B) Brake pedal connector lock
 (C) Throttle control lever
 (D) Forward drive pedal
 (E) Reverse drive pedal
 (F) Power Take Off (PTO) switch

6. Move the range gear lever to the N (neutral) position.

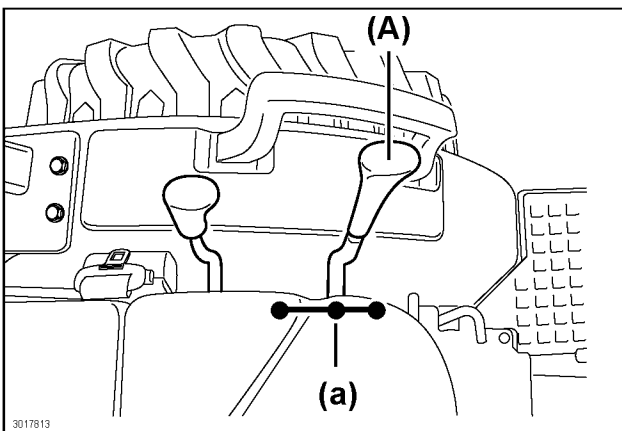

- (A) Range gear lever
 (a) N (neutral) position

7. Push the 3-point hitch control lever forward to lower any implements to the ground.

NOTE

- Use the implement control lever to lower any attached mounted implements to the ground.

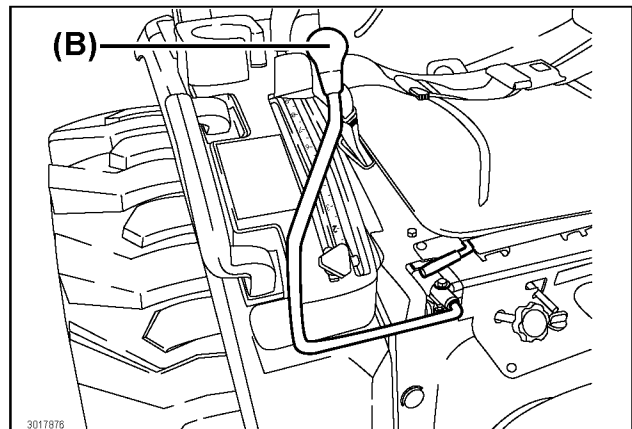
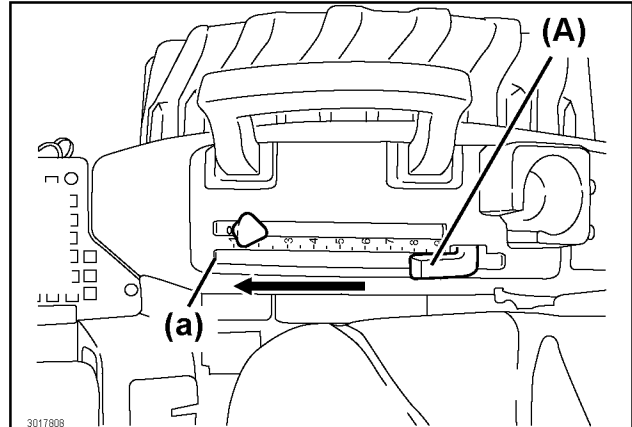

- (A) 3-point hitch control lever
 (a) Lower the implement
 (B) Implement control lever

⚠ WARNING

- To prevent injury or property damage:
 - always lock the parking brake when the range gear lever is in N (neutral) position:
 - whether the engine is running or stopped
 - the tractor wheels are free to move when the range gear lever is in the N (neutral) position

8. OPERATE THE TRACTOR

8. Engage the parking brake securely, for details, see "6. Lock and Set the Parking Brake" on page 7-3.

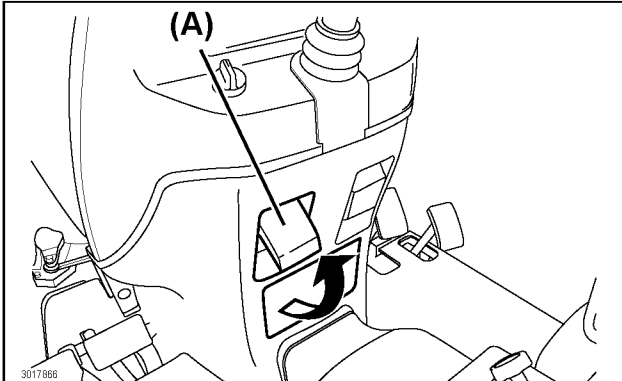

(A) Parking brake lock lever

9. Pull the throttle control lever backward.
Let the engine run at idle speed for 2 minutes.

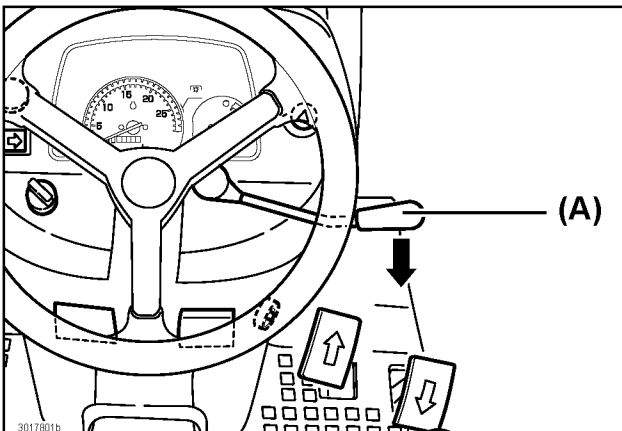

(A) Throttle control lever

NOTE

- Always let the engine run at idle speed for 2 minutes before shutting down.
- Observe the preceding procedure after hard or long operations.
- The preceding action allows the engine to cool down and prevents damage to the engine.

10. Turn the starter key switch to the OFF position.

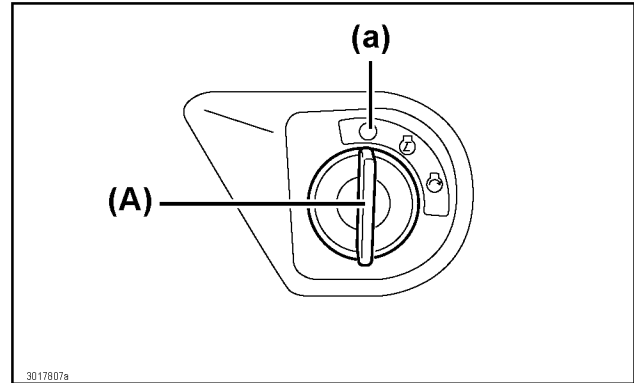

(A) Starter key switch
(a) OFF position

11. Remove the key from the starter key switch.

■ Stop in an Emergency

1. Release the forward drive pedal or the reverse drive pedal completely.
2. Depress both brake pedals to stop the tractor.
3. Turn the starter key switch to OFF position.
4. If possible, lock the parking brake securely, for details, see "6. Lock and Set the Parking Brake" on page 7-3.

5. Use the Brake

Engage the Parking Brake

WARNING

- Before leaving the tractor unattended:
 - always engage the parking brake securely
 - always remove the key from the starter key switch
- The preceding practice prevents a child and other people from attempting to drive or operate the tractor.

1. Use the brake pedal connector lock to connect the left and right brake pedals together.
2. Depress the brake pedals fully.
3. While depressing the brake pedals fully, pull up the parking brake lock lever securely.
4. Remove the foot from the brake pedals.
5. Make sure the parking brake is securely locked.

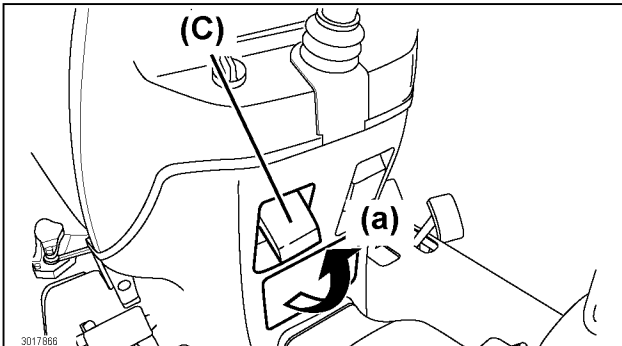
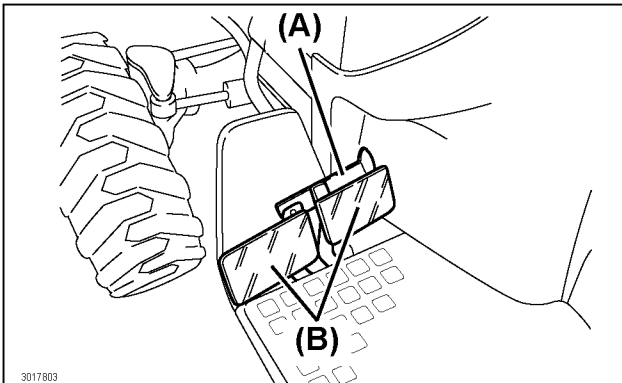

(A) Brake pedal connector lock
 (B) Brake pedals
 (C) Parking brake lock lever
 (a) Locked

Disengage the Parking Brake

WARNING

- Always park the tractor on a solid and level ground. If parking on a slope is unavoidable:
 - chock all the tires safely and securely
 - engage the parking brake securely, for details, see "6. Lock and Set the Parking Brake" on page 7-3

1. Depress both locked brake pedals.
2. Push all the way down the parking brake lock lever.
3. Release the locked brake pedals.
4. Make sure the parking brake is disengaged.

Use the Brake Pedals as Driving Brake (On Roads)

WARNING

- To prevent accidental tipping or overturning.
 - do not under any circumstances use unlocked brake pedals to stop the tractor at high speeds
- Move counterclockwise the brake pedal connector lock to lock together the left and right brake pedals when:
 - the brake pedals are not used for turning
 - traveling on roads
- Always slow down before making turns.

1. Lock the brake pedal connector lock.
2. The preceding actions lock the two brake pedals together.
3. Depress the locked brake pedals to slow down or stop the tractor.

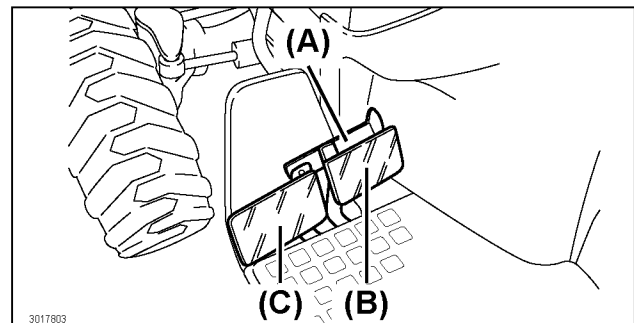

(A) Brake pedal connector lock
 (B) Right turn brake pedal
 (C) Left turn brake pedal

■ Use the Brake Pedals for Easier Turning

IMPORTANT

- To prevent damage to the 3-point hitch and implements:
 - always keep the implement away from the ground during brake turning

NOTE

- To perform tighter turns, unlock the brake pedal connector lock.
- The preceding action can reduce the number of times the operator needs to back up the tractor.
- Always keep the brake pedals locked together when:
 - moving to another site
 - traveling on roads

1. Unlocked the brake pedal connector lock.
2. Make sure that the two brake pedals functions independently.
3. To make tighter left turn: Depress the left brake pedal (C) while turning left.
4. To make tighter right turn: Depress the right brake pedal (B) while turning right.

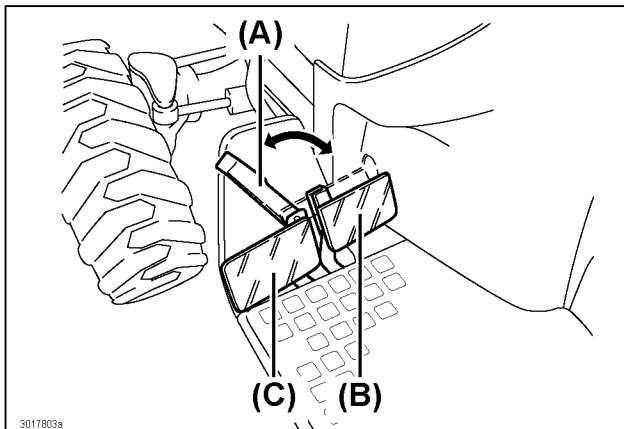

(A) Brake pedal connector lock
 (B) Right turn brake pedal
 (C) Left turn brake pedal

6. Practices for Safe Operation

■ Differential Lock

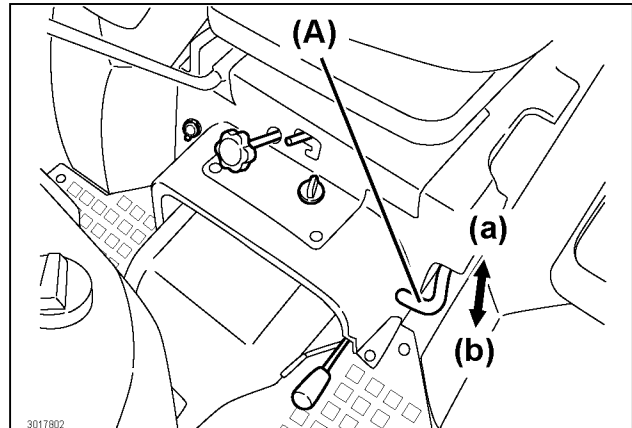

(A) Differential lock pedal
 (a) Disengaged position
 (b) Engaged position

WARNING

- To prevent tipping of the tractor:
 - do not attempt to turn with the differential lock engaged
 - do not engage the differential lock while the tractor is traveling at a high speed

IMPORTANT

If differential lock does not disengage after removing foot from the differential lock pedal:

- Depress brake pedals to equalize traction.
- Release the differential lock pedal.

1. When rear wheels begin to slip:
 - Engage the differential lock to gain greater traction.

NOTE

- Engaging the differential lock:
 - locks the right and left rear axles
 - the right and left rear axles simultaneously rotate at the same speed
 - the preceding action allows the tractor to develop maximum traction force

IMPORTANT

- To prevent damage to the differential gears, always disengage the differential lock while travelling at high speed.
- The differential lock is designed to be used for short durations.
- Prolonged use can damage the differential gears.

8. OPERATE THE TRACTOR

Engage the Differential Lock

1. Stop the tractor.
2. Drive the tractor at a very slow speed.
3. Depress the differential lock pedal.

Disengage the Differential Lock

1. Release the differential lock pedal completely.

IMPORTANT

- Always decrease the engine speed when using the differential lock.
- To prevent transmission damage, always unlock the differential lock while only one rear wheel is rotating.
- If the differential lock does not disengage when the foot is removed from the differential lock pedal, try depressing lightly on the brake pedals several times.

■ Drive the Tractor on Roads

WARNING

Exercise due caution when driving the tractor on roads. Follow the following instructions.

- Turn on the hazard lights.
- Before operating the tractor on a road, become familiar with the relevant state or local regulations in effect.
- Always have an implement safety lighting kit available from YOUR LOCAL YANMAR TRACTOR DEALER.
- Use the turn signal lights during turning.
- Always keep the Slow Moving Vehicle (SMV) emblem on the original position.
- Perform the following precautions:
 - always ensure that the brake pedal connector lock is securely locked
 - always ensure the Slow Moving Vehicle (SMV) emblem and hazard lights are clean and clearly visible
 - while towing equipment, install Slow Moving Vehicle (SMV) emblem and hazard lights on the towed equipment
 - always ensure that the Slow Moving Vehicle (SMV) emblem is visible while a rear mounted implement is mounted

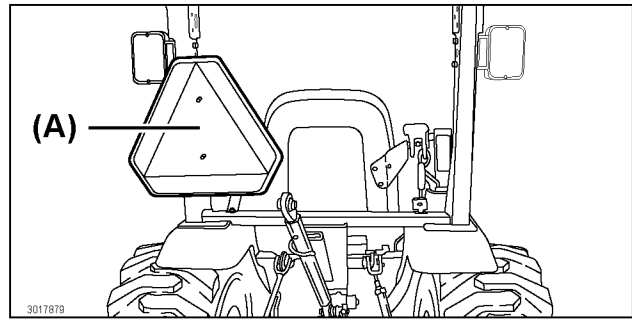

(A) Example of a typical installed Slow Moving Vehicle (SMV) emblem

1. Turn the hazard lights and headlights ON, unless prohibited by law.
2. Secure the implement being towed with the lock hitch pins and safety chain.
3. Slowly drive the tractor to be able to control the tractor at all times.
4. Slow down when:
 - Travelling on slopes and rough roads.
 - Executing sharp turns.
 - Transporting a heavy rear mounted implement.
5. Adjust the tire tread width of the rear wheels to attain maximum stability. For adjusting tire tread width, for details, see "Change the Tire Tread Width" on page 12-3.
6. Disengage the 4-wheel drive to prevent excessive tire wear.
7. Do not under any circumstances coast downhill.
8. Check whether the 4-wheel drive is engaged.
9. The braking characteristics differ between the 2-wheel drive and 4-wheel drive. Always be aware of the current drive mode and drive accordingly.
10. Always slow down before turning. High speed turns can cause the tractor to tip over.
11. Always ensure the Slow Moving Vehicle (SMV) emblem is on the tractor and is clearly visible.
12. Strictly observe all the currently effective local traffic and safety laws and regulations.
13. Always travel at a speed such that the tractor can be controlled and is stable.
14. Do not engage the differential lock while traveling on roads. The preceding action can make the tractor uncontrollable.
15. While traveling on roads, avoid sudden turning of the steering wheel. The preceding action makes the tractor unstable resulting in an extremely dangerous situation.
16. While on the road, avoid under any circumstances operate an implement.

8. OPERATE THE TRACTOR

17. While driving on a road with an implement attached to the 3-point hitch:
- Set the 3-point hitch control lever to the raised position.
 - Lock the 3-point hitch control lever with the position stop knob.
 - During the use of hydraulic flow control/stop knob to raise the implements:
 - avoid fully closing hydraulic flow control/stop knob that may damage the hydraulic lift circuit

■ Push or Tow the Tractor

⚠ WARNING

- **When towing the tractor:**
 - travel slower than 10 mph (16 km/h)
 - always have another person sit on the tractor to allow independent operation of the steering and brakes when required

1. Push down Power Take Off (PTO) switch to OFF position.
2. Disengage the differential lock.
3. Disengage the parking brake.
4. Move the range gear lever to N (neutral) position.
5. Disengage the 4-wheel drive.

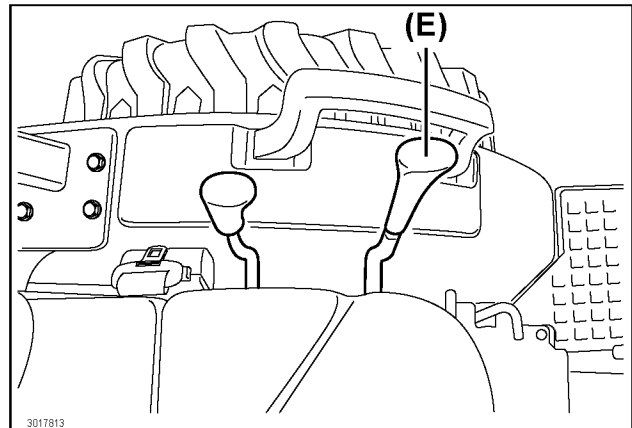
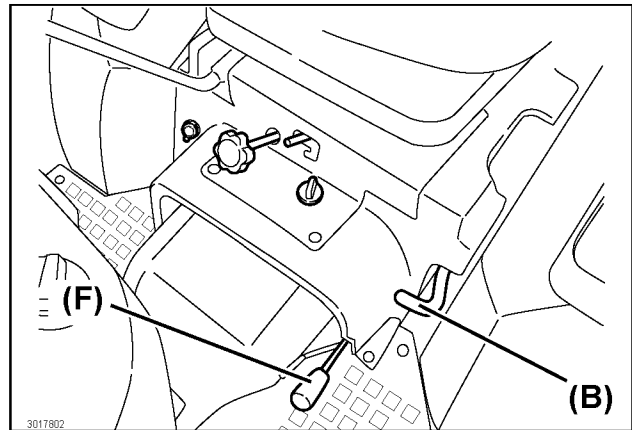
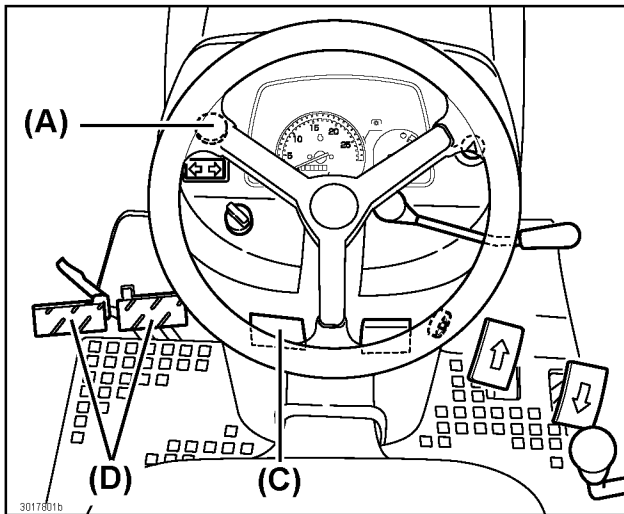

- (A) Power Take Off (PTO) switch
(B) Differential lock pedal
(C) Parking brake lock lever
(D) Brake pedals
(E) Range gear lever
(F) 2WD/4WD lever

■ Allowable Loads When Towing with the Tractor

⚠ WARNING

- When towing, the distance required to stop the tractor proportionally increases with the:
 - tractor speed
 - weight of the load being towed
 - angle of a slope
- Towing loads too heavy for the tractor:
 - can result in loss of control of the tractor
 - regardless of whether the load itself has brakes or not
- Towing at excessively high speed can result in loss of control of the tractor.
- Before towing, always ensure that the tractor has the capability to handle the total weight of all equipment and loads.

8. OPERATE THE TRACTOR

Always comply with the recommended maximum road speeds or local speed limits:

- When towing equipment, travel at a speed of less than 9.3 mph (15 km/h).
- Make sure the tractor has the capability to tow the equipment and loads. For details, see "Chapter 4. IMPLEMENT CAPACITIES".

CAUTION

- Make sure the tractor is heavy and powerful enough for the load being towed.
- Make sure the tractor has sufficient braking power for the load being towed.
- If the load exceeds the recommended weight ratio:
 - add weight to the tractor
 - lighten the load
 - get a heavier tractor
- Exercise caution when towing loads:
 - on difficult surface
 - when turning
 - on a slope

WARNING

Avoid injury!

- If the towed equipment is not equipped with brakes:
 - travel slower than 9.3 mph (15 km/h)
 - tow loads weighing less than 1.5 times the tractor weight
- Even if the towed equipment is equipped with brakes:
 - travel slower than 18.6 mph (30 km/h)
 - tow loads weighing less than 4.5 times the tractor weight

1. Hitch the load to the drawbar.
2. Lock the drawbar and pin in place.

NOTE

- Always use the drawbar to tow a load.
- Do not under any circumstances attach a load to the axle housing or any other location besides the drawbar.

3. Attach a safety chain between the tractor drawbar support and the load.

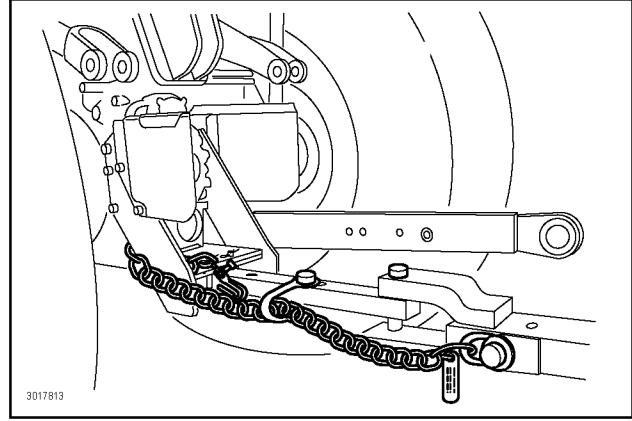

4. Always allow enough slack in the safety chain to enable turning.

NOTE

- On a slope:
 - make sure the gear is low enough to allow the operator to control the speed of the tractor without having to use the brake pedals

■ Transport the Tractor on a Trailer

WARNING

- Exercise extreme care during loading or unloading the tractor to or from a trailer or truck.
- Turn the fuel shut-off valve to the OFF (closed) position.

1. Make sure the trailer is heavy duty enough to transport the tractor.
2. Drive the tractor forward onto the trailer.
3. Lower any implement onto the trailer deck.
4. Engage the parking brake securely, for details, see "6. Lock and Set the Parking Brake" on page 7-3.
5. Shut off the engine.
6. Remove the key from the starter key switch.
7. Turn the fuel shut-off valve to the OFF (closed) position.
8. Tie down the tractor to the trailer with heavy duty straps, chains or cables.
 - Secure each of the tire to the trailer.

IMPORTANT

- The trailer must have signs and lights as required by law.

■ Operate on Slopes and Rough Terrain

WARNING

Be extremely cautious when driving the tractor on a slope and rough terrain. Observe the following precautions.

- Before driving the tractor on a slope or a rough terrain, engage the 4-wheel drive for the following purposes:
 - to increase traction
 - to greatly assist in climbing steep slopes
 - to improve braking power on sloped, frozen, wet or graveled surfaces
 - always be aware that the danger of tipping over is still present
- Add weight to the tractor as necessary.
- Drive at a lower speed to prevent skidding and loss of steering control.
- Keep away from slopes steeper than 15 degrees.
- Avoid parking the tractor perpendicular to the slope.
- Avoid turning or changing travel directions on a slope.
- Before approaching a slope, select an appropriate speed setting.
- Make sure to travel at a lower speed when on a slope.
- Avoid shifting the range gear lever while traveling on a slope. The preceding action can make the tractor uncontrollable and suddenly roll down the hill.
- Do not move the range gear lever in N (neutral) position when on the slope.
- Sudden operating the tractor on an uphill slope can cause the front wheels to lift off the ground and result in an extremely dangerous situation.
- To prevent the preceding danger:
 - run the engine at a lower speed
 - slowly start the tractor

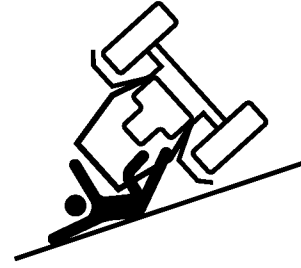

3013748

- Avoid parking the tractor perpendicular to a slope.
 - if parking on a slope is unavoidable, chock all the tires safely and securely and engage the parking brake securely, for details, see "6. Lock and Set the Parking Brake" on page 7-3
- On a slope, the tractor is unstable and more prone to severe injury or even death. Always be alert.
- Avoid traveling backward, up and down on a slope to prevent tipping over.
- Keep away from ditch or deep mud to avoid the risk of the tractor tipping over.
- Always drive slowly on any slope. Avoid under any circumstances sudden change of speeds or directions.
- For increased stability of the tractor on slope:
 - always use tires with the widest possible tire tread width
 - follow the instructions for proper weighting
 - for details, see "Chapter 12. TIRES, WHEELS AND WEIGHT" on page 12-1

8. OPERATE THE TRACTOR

1. Before approaching a slope, select a lower gear setting.

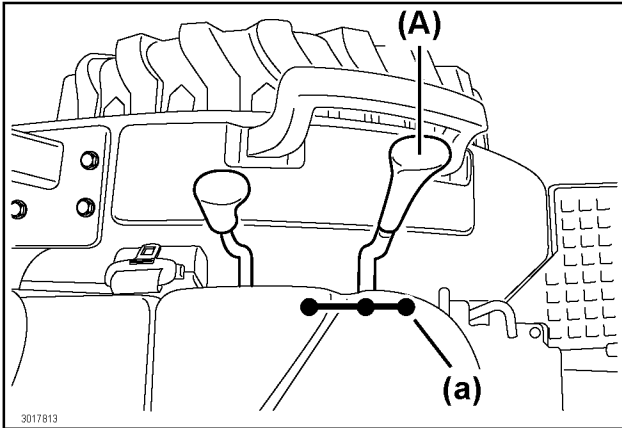

(A) Range gear lever
(a) Shift to a lower speed

2. Always travel slowly on a slope.
3. Drive the tractor according to the type of a slope, as indicated below.

■ Uphill and Downhill Slopes

- Start slowly.
- Make sure the range gear is in a slow gear.
- Run the engine at a lower speed.

■ Steep Downhill Slope

- Move the range gear lever to the lower speed position before going a downhill slope.
 - the preceding action sets the level of engine brake
- Select the range gear lever position suitable for the steepness of a slope.

⚠ WARNING

Avoid injury!

- When backing up a slope, keep the tractor parallel with the inclination of the slope.

■ About the Power Steering

⚠ WARNING

Avoid injury!

- The tractor equipped with power steering.
 - the steering wheel can turn with minimum force while the engine is running
- Avoid abrupt turning of the steering wheel, especially while traveling on paved roads.
 - the preceding action can cause an accident

1. The power steering only function when the engine is running.
2. When the engine is running at slow speed, the operator may need to exert a slightly greater force to turn the steering wheel.
3. The preceding state is normal.

IMPORTANT

- Fully turning the steering wheel causes the relief valve to trip. An audible signal is emitted.
 - the preceding state can be ignored only for a short duration
- Do not under any circumstances keep the steering wheel fully turned for an extended period of time.
- As much as possible, avoid turning the steering wheel while the tractor is not moving.
- Avoid turning the steering wheel of the tractor while the engine is shut off, unless while towing the tractor.
 - the preceding action can damage the steering valve, tires and rims

9. POWER TAKE OFF (PTO) SYSTEM

⚠ WARNING

Avoid injury!

- Before connecting, disconnecting, adjusting, cleaning or servicing any Power Take Off (PTO) driven implement:
 - always ensure all moving components have completely stopped rotating
- Always ensure Power Take Off (PTO) shaft shield is installed while the Power Take Off (PTO) is not in use.
- Before attempting to replace the Power Take Off (PTO) shaft cap:
 - always wait until the shaft has completely stopped moving
- Before installing or operating any Power Take Off (PTO) driven implements:
 - always follow Power Take Off (PTO) driven implement *Operator's Manual*, safety decals and instructions
- Always engage the parking brake securely, for details, see "6. Lock and Set the Parking Brake" on page 7-3 and chock all the tires safely and securely.
- Avoid approaching or touching any rotating component.

1. Operate the Power Take Off (PTO) System

⚠ WARNING



- Before connecting, disconnecting, adjusting or cleaning any Power Take Off (PTO) driven implement:
 - push down Power Take Off (PTO) switch to OFF position
 - shut down the engine
 - make sure all rotating component have stopped
- Avoid approaching rotating drivelines.
- Entanglement with a rotating driveline can lead to serious injury or even death.
- Keep away from rotating driveline.
- Keep clothing away from rotating driveline.
- Make sure all shields and guards are in position and are correctly installed.
- Do not run the engine at 2750 Revolutions Per Minute (rpm) or more while Power Take Off (PTO) switch is ON position.

9. POWER TAKE OFF (PTO) SYSTEM

1. The tractor comes equipped with a hydraulic/ electric controlled Power Take Off (PTO) system.
2. Select the appropriate Power Take Off (PTO) operation for the job.
 - Use the Mid-/Rear Power Take Off (PTO) select lever.
3. Pull up the Power Take Off (PTO) switch to turn ON the Power Take Off (PTO) system.
4. Push down the Power Take Off (PTO) switch to turn OFF the Power Take Off (PTO) system.

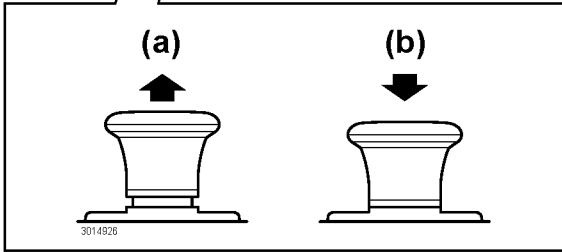
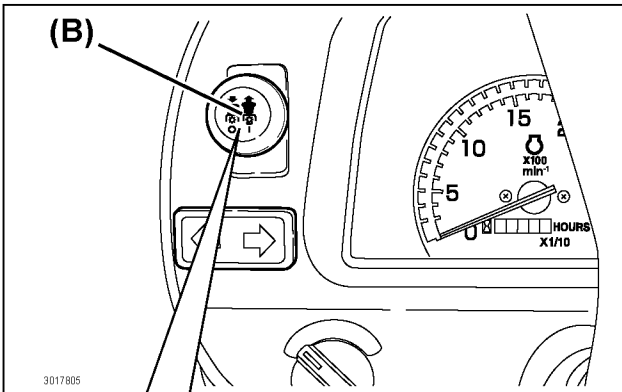
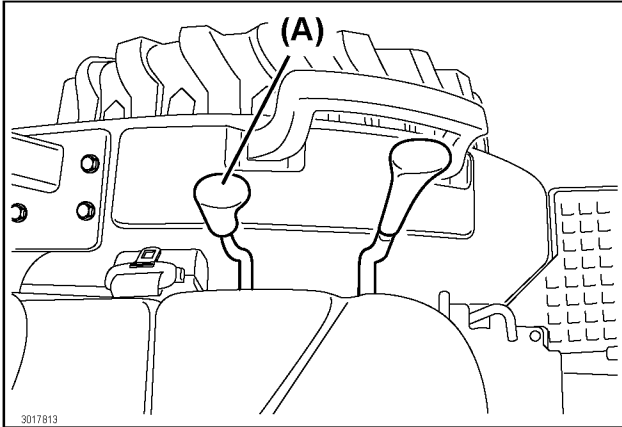

- (A) Mid-/Rear Power Take Off (PTO) select lever
(B) Power Take Off (PTO) switch
(a) ON position
(b) OFF position

■ Determine the Appropriate Power Take Off (PTO) Speed

1. At the standard Power Take Off (PTO) speed (540 Revolutions Per Minute (rpm)), the engine should be run at 2600 Revolutions Per Minute (rpm).
2. The RATED mark on the tachometer indicates the appropriate engine speed.
3. Be always aware of the current tractor speed. Make sure that the tractor is controllable.
4. When Power Take Off (PTO) switch is in the ON position:
 - Always drive below the indicated RATED Revolutions Per Minute (rpm).

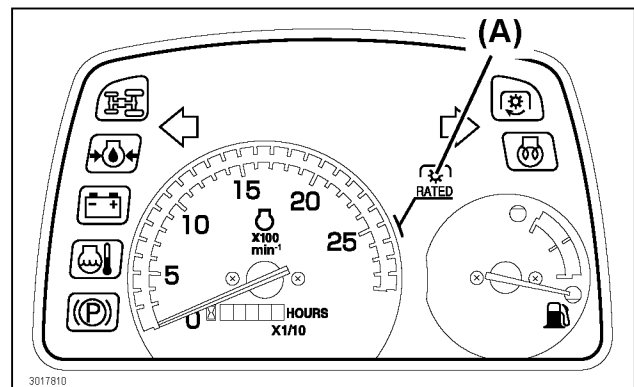

(A) RATED mark

■ Engage Power Take Off (PTO) (with the operator on the operator seat)

NOTE

- Do not stop the engine while Power Take Off (PTO) switch is in the ON position.
- When the operator leaves the operator seat while the engine is running (with Power Take Off (PTO) engaged):
 - the safety interlock system shuts down the engine
 - the system also stops all operations on the tractor

1. To engage Power Take Off (PTO):
 - Idle the engine speed.
 - Move the Mid-/Rear Power Take Off (PTO) select lever to required position for the job.
 - Pull up Power Take Off (PTO) switch to ON position.
2. Increase the engine speed required for the implement.

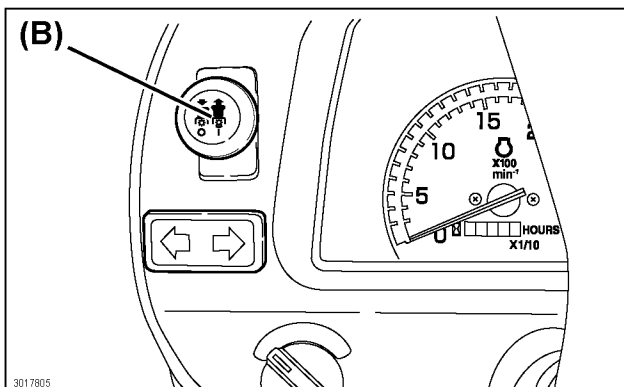
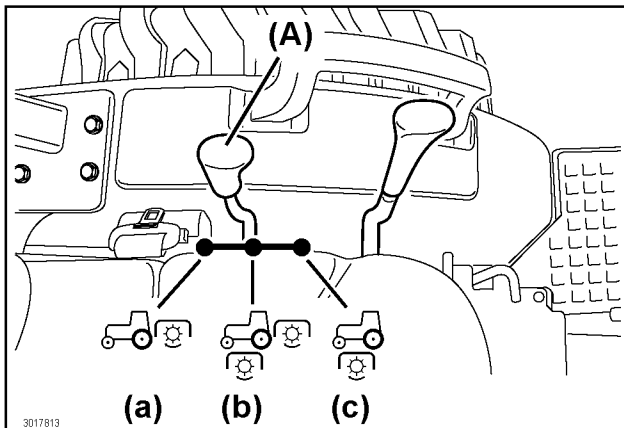

(A) Mid-/Rear Power Take (PTO) select lever
 (a) Operating the Rear Power Take Off (PTO) only
 (b) Operating the Mid-Power Take Off (PTO) and the Rear Power Take Off (PTO) simultaneously
 (c) Operating the Mid-Power Take Off (PTO) only
(B) Power Take Off (PTO) switch

■ Engage the Rear Power Take Off (PTO) (with the operator out of the operator seat)

IMPORTANT

- ALWAYS use a rear mounted implement that is rated at 540 Revolutions Per Minute (rpm), to prevent damage to the tractor or the implement.
- Do not run the engine beyond the RATED speed while the Power Take Off (PTO) system is activated.

NOTE

- The Rear Power Take Off (PTO) can be operated with the operator not sitting on the operator seat.
- The operator needs to be sitting on the operator seat when starting the engine.
- The operation of the Power Take Off (PTO) stops when the range gear lever is moved to either the L (slow) or H (fast) position.
- Engage the parking brake securely, for details see, "6. Lock and Set the Parking Brake" on page 7-3 when operating the Rear Power Take Off (PTO).
- The Mid-Power Take Off (PTO) can only be operated with the operator on the operator seat.
- Use the Mid- and Rear Power Take Off (PTO) simultaneously only when the operator is sitting on the operator seat.

1. Engage the parking brake securely, for details see, "6. Lock and Set the Parking Brake" on page 7-3.
2. Check all the tires safely and securely.
3. Move the throttle control lever to set the engine speed to 1500 Revolutions Per Minute (rpm) or lower.
4. Move the Mid-/Rear Power Take Off (PTO) select lever backward to the Rear Power Take Off (PTO) position.
5. Pull up the Power Take Off (PTO) switch to ON position to engage the Rear Power Take Off (PTO) system.
6. Raise the engine to the RATED speed. The Rear Power Take Off (PTO) shaft now rotates at 540 Revolutions Per Minute (rpm).
7. Check that the parking brake is engaged securely.
8. The operator can now leave the operator seat to tend to the operation of the attached rear implement.

■ **Disengage Power Take Off (PTO) (with the operator on the operator seat)**

1. Idle the engine speed.
2. Push down Power Take Off (PTO) switch to OFF position.

2. Use the Power Take Off (PTO) Safely

WARNING



- Stay clear of rotating drivelines.
- Before approaching the driveline:
 - push down Power Take Off (PTO) switch to OFF position
 - shut down the engine
 - make sure all rotating components have stopped
- Entanglement with a rotating driveline can lead to serious injury or even death.
- Keep away from rotating driveline.
- Keep clothing away from rotating driveline.
- Make sure all shields and guards are in position and are correctly installed and used.

■ **Use the Power Take Off (PTO) Shaft Cap**

Remove the Power Take Off (PTO) shaft cap before connecting an implement driveline joint to any Power Take Off (PTO) shaft/s.

- To remove the Power Take Off (PTO) shaft cap:
 - rotate the shaft cap 15 degrees counterclockwise
 - pull out the shaft cap from the Power Take Off (PTO) shaft
 - store the shaft cap in a proper place
- Install the Power Take Off (PTO) shaft cap when:
 - the implements driveline joint has been disconnected from the Power Take Off (PTO) shaft/s

IMPORTANT

- Always install the Power Take Off (PTO) shaft cap to the Rear Power Take Off (PTO) shaft when both Power Take Off (PTO) shafts are not used.

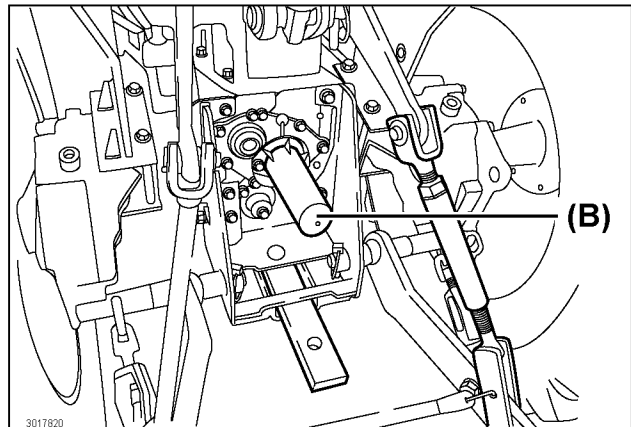
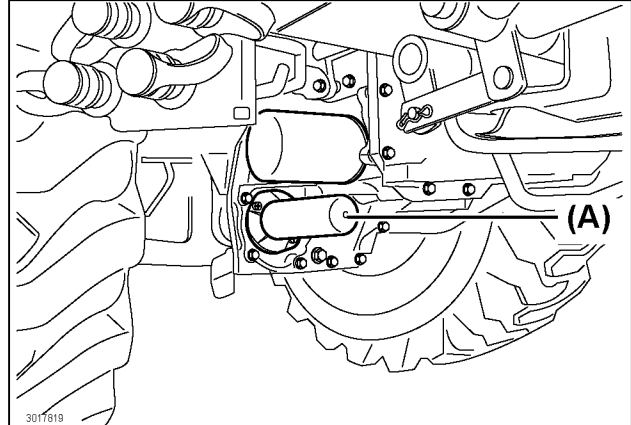

The Power Take Off (PTO) shaft cap installation locations.

(A) Mid-Power Take Off (PTO)

(B) Rear Power Take Off (PTO)

3. Install an Implement to the Power Take Off (PTO) Driveline

 **WARNING**

Avoid injury!

- Before installation of an implement to Power Take off (PTO) driveline:
 - make sure that the tractor is stopped
 - make sure that Power Take Off (PTO) switch is in the OFF position

IMPORTANT

- Observe the driveline manufacturer installation instructions for:
 - driveline mounting angle
 - length of the overlaps on the driveline shafts
- An incorrectly installed implement can promote wear of the driveline and/or damage the tractor.

NOTE

- To operate the Mid-Power Take Off (PTO), the operator must be sitting on the operator seat.

10. 3-POINT HITCH AND DRAWBAR

⚠ WARNING

- When there is a 3-point hitch-mounted implement:
 - always install an appropriate weight to the front of the tractor
- During transportation:
 - place the 3-point hitch control lever in the raised position
 - lock the 3-point hitch control lever with the position stop knob for the 3-point hitch control lever
- Do not fully close the hydraulic flow control/stop knob in order to keep any implements in the raised position while the tractor is traveling.
 - completely closing the hydraulic flow control/stop knob can damage the hydraulic lift circuit
- Only use implements that are designed for use with the 3-point hitch.
- Always use approved implements with the 3-point hitch.
- Contact YOUR LOCAL YANMAR TRACTOR DEALER for technical assistance.

1. 3-Point Hitch

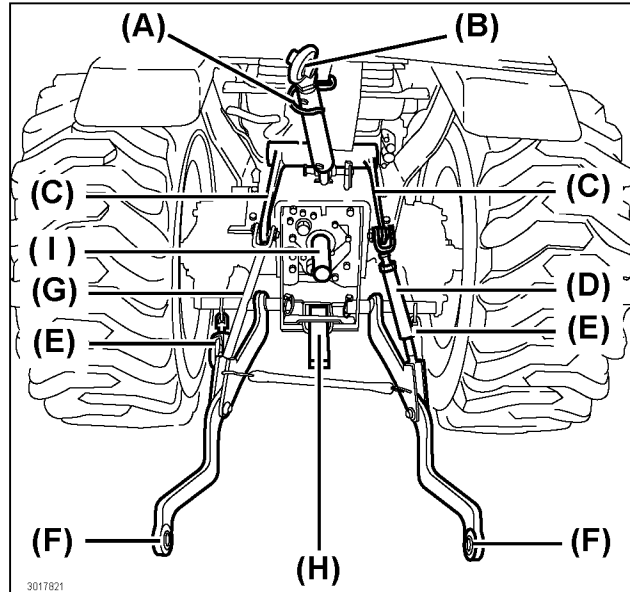

- (A) Top link hook
- (B) Top link
- (C) Left arm, Right arm
- (D) Lift Link right
- (E) Check chain (adjustable)
- (F) Lower links
- (G) Lift Link (non-adjustable) (left)
- (H) Drawbar
- (I) Power Take Off (PTO) shaft cap (if installed)

■ Use the 3-Point Hitch Control Lever

NOTE

- The 3-point hitch delivered with the tractor is a Category 1.

1. Use the 3-point hitch control lever to raise and lower the implement attached to the 3-point hitch.

NOTE

- The 3-point hitch control lever is labeled 1 to 9.
- The numbers:
 - for reference purposes only
 - does not indicate any exact height position for the implement that is attached to the 3-point hitch
- The lower the number, the closer the lower links is to the ground.

2. Adjust the position stop knob to set the desired lowest position of the implement from the ground.

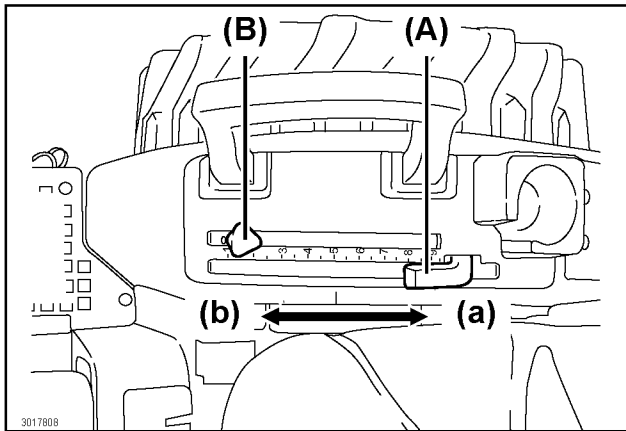

(A) 3-point hitch control lever

(B) Position stop knob

(a) Moving the 3-point hitch control lever backward raises the implement.

(b) Moving the 3-point hitch control lever forward lowers the implement.

■ Use the Position Stop Knob

NOTE

Use the position stop knob to:

- Limit the downward movement of the lower links.
- Set a minimum distance between the attached implements and the ground.

1. Operate the attached implement.

2. Use the 3-point hitch control lever to establish the desired working height (distance from the ground) of the implement.
3. Loosen the position stop knob.
4. Move the position stop knob rearwards until position stop knob stops against the 3-point hitch control lever.
5. Tighten the position stop knob to fix on that particular position.
 - Every time the 3-point hitch control lever stops against the position stop knob, the implement is lowered to the established working height.

■ Hydraulic Flow Control/Stop Knob

⚠ WARNING

- Lowering the 3-point hitch too fast can lead to accident or tractor failure.
- Adjust the hydraulic flow control/stop knob:
 - the time for lowering the implement from the highest position to the lowest position, is 2 seconds or longer
- Do not attempt to operate an implement on a road.
- While the tractor is traveling:
 - keep the 3-point hitch control lever in the raised position
 - lock the 3-point hitch control lever with the position stop knob
 - do not fully close the hydraulic flow control/stop knob
 - closing the hydraulic flow control/stop knob can cause damage to the hydraulic lift circuit
- During maintenance:
 - do not use the hydraulic flow control/stop knob as a means to keep the implements raised
 - loss of hydraulic pressure may cause the implement to suddenly drop
 - set the implement on solid blocks, or remove the implement before starting any maintenance
- The hydraulic flow control/stop knob determines the speed at which the lower link is lowered.

IMPORTANT: Avoid damage!

- Avoid attaching a heavy load to the 3-point hitch when traveling on rough terrain.
 - the hydraulic system may be damaged
- Do not operate the 3-point hitch control lever when the hydraulic flow control/stop knob is closed.
 - the preceding action can cause the transmission hydraulic oil to overheat

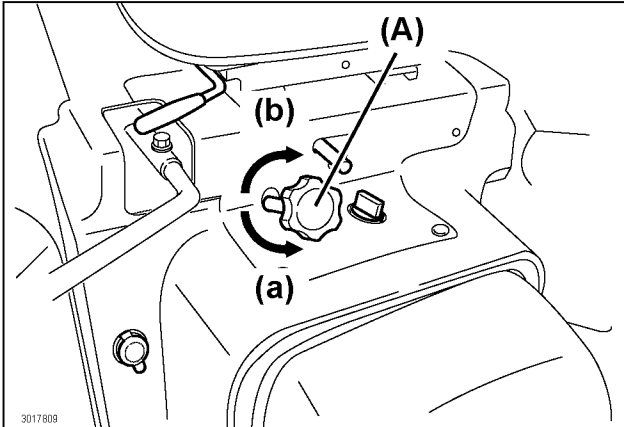

(A) Hydraulic flow control/stop knob

- (a) Knob turned counterclockwise:
- increases the rate of drop speed
 - unlocks the hydraulic lift
- (b) Knob turned clockwise:
- decreases the rate of drop speed
- Knob turned clockwise until the knob stops turning:
- locks the hydraulic lift

Use the Lower Links (and Top Link as Needed)

WARNING

Avoid injury!

- Always be extremely careful when backing up the tractor.
- Always clear the surrounding area of the tractor from bystander/s and obstacle/s before starting to back up.
- While backing up, always watch for bystander/s and obstacle/s along the way.
- Engage the parking brake securely, for details, see "6. Lock and Set the Parking Brake" on page 7-3 before getting in between the tractor and the implements to be installed or removed.
- Check for any interference between the implement and the tractor and/or driveline separation:
 - whenever a Power Take Off (PTO) driven implement is installed to the 3-point hitch

1. Slowly back up the tractor into a position where the lower links are aligned with the implement lift brackets.
2. Park the tractor safely and securely.
 - For details, see "7. Safe Practices for Parking the Tractor" on page 1-7.
3. Chock all the tires safely and securely.

NOTE

- Always remove the drawbar to prevent interference with the implements to be mounted.

10. 3-POINT HITCH AND DRAWBAR

4. Connect the lower links to the implement.
5. As necessary, unhook the top link from the top link hook, and connect to the implement.
6. Use lynch pin to secure the implement.

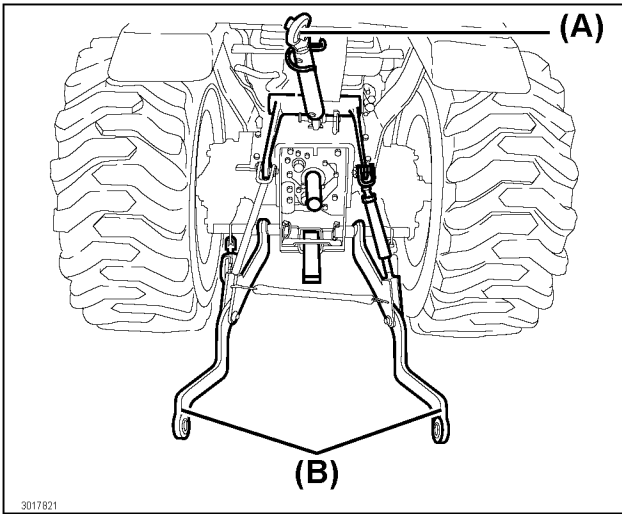

(A) Top link
(B) Lower links

NOTE

- Whenever the top link is not used, always place the top link in the top link hook.

■ Level the Implement Front to Rear

1. Park the tractor safely and securely.
 - For details, see "7. Safe Practices for Parking the Tractor" on page 1-7.
2. Chock all the tires safely and securely.

NOTE

- Always place the top link in the top link hook when the 3-point hitch is not in use.

3. Relieve the tension on the top link by lowering the implement to the ground.
4. Loosen the locknut.
Rotate the top link body to lengthen or shorten the top link, as required.

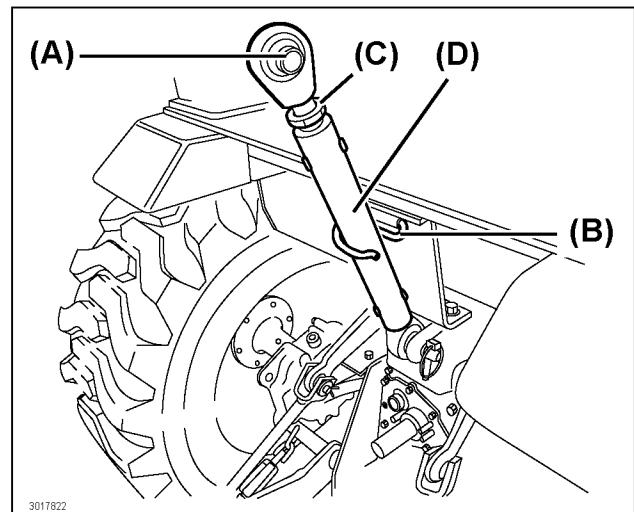

(A) Top link
(B) Top link hook
(C) Locknut
(D) Top link body

IMPORTANT: Avoid damage!

- Avoid over turning the top link body all the way to the end, the preceding action can damage the threads.

5. Raise the implement.
Check if the desired levelness is attained. Re-adjust the top link as necessary.
6. Once the desired levelness is attained, tighten the locknut.

■ **Level the Implement Side to Side**

1. Park the tractor safely and securely.
 - For details, see "7. Safe Practices for Parking the Tractor" on page 1-7.
2. Chock all the tires safely and securely.
3. Lower the implement to the ground.
4. Loosen the locknut located on the lift link right.
5. Rotate the body of the lift link right to raise or lower the lower link.

Do the preceding action until the desired levelness of the implement is attained.
6. Tighten the locknut.

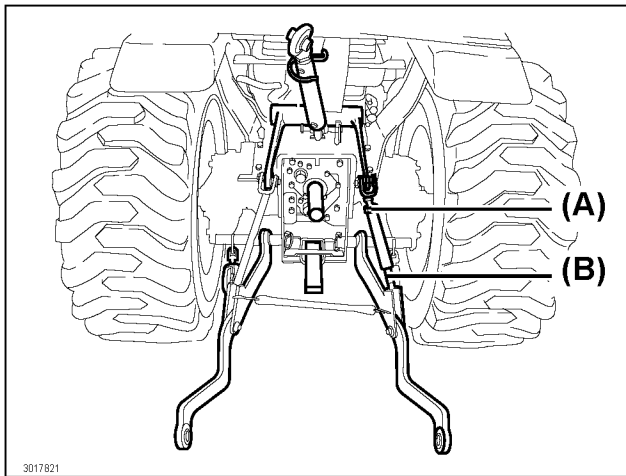

(A) Locknut
(B) Lift link right

■ **Adjust the Stabilizer**

NOTE

- Check the procedure for adjusting the stabilizer in the *Operator's Manual* for the implement.
- Once the check chain has been properly adjusted, side sway of the implement can be controlled by the position of the links.

1. Park the tractor safely and securely.
 - For details, see "7. Safe Practices for Parking the Tractor" on page 1-7.
2. Chock all the tires safely and securely.
3. Lower the implement to the ground.
4. Remove the ring clip.
5. Rotate the turnbuckle to adjust the length of the check chain.
6. Install the ring clip.

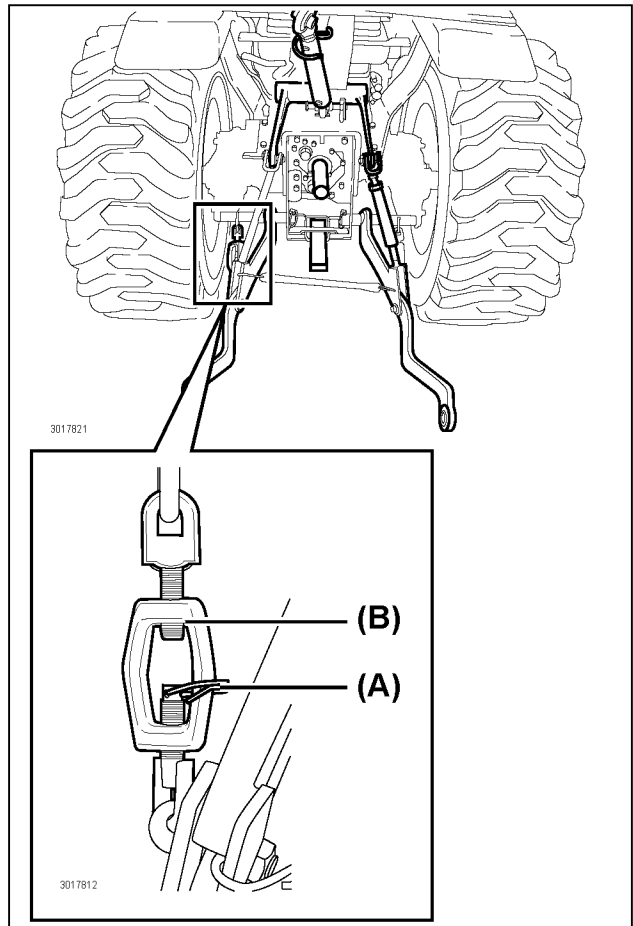

(A) Ring clip
(B) Turnbuckle

2. Drawbar

WARNING

Avoid injury!

- Always use the drawbar to attach a trailer or towed implement.
- Attempting to attach a trailer or towed implement at the top link or rear axle can cause the tractor to tip over.
- Only use the drawbar that is provided with the tractor.
 - avoid installing or using a floating type or any other type of the drawbar
- Always hitch loads being towed to the drawbar.
 - the preceding action prevents the tractor from tipping over rearward
- Avoid attaching a longer drawbar.
 - the preceding action can damage the attached section
 - the same action can cause the implement to become disconnected

NOTE

- The tractor comes equipped with a stationary drawbar.
- Always remove the drawbar before attaching any 3-point hitch implement.

■ Maximum Drawbar Loads

IMPORTANT

- Make sure that the static vertical load on the drawbar does not exceed the maximum recommendations.
- Always travel slowly when towing heavy loads.

CAUTION

- Certain heavy equipment, such as a loaded single axle trailer, can place excessive strain on the drawbar.
- Such strain is also greatly increased by speed and rough ground.

1. Avoid attaching very heavy equipment (e.g., a loaded single axle trailer) that exerts excessive strain on the drawbar.
2. Avoid exceeding the maximum vertical load of 529 lb. (240 kg) on the drawbar.
3. The strain is greatly increased by high speed and rough ground.

■ Deploy/Stow the Drawbar

IMPORTANT

- Make sure that the drawbar is removed before using the Power Take Off (PTO) driven/drawn implement.

NOTE

- The drawbar is equipped with 3 operation adjusting holes.
- Use the holes to adjust the drawbar length.

1. Remove the ring.
2. Remove the pin.
3. Align the hole (a) of the drawbar with the drawbar bracket to set the drawbar length.

NOTE

To secure the drawbar in the stowed position while Power Take Off (PTO) driven implement is not used:

- Remove the ring and pin.
- Slide in the drawbar until the positioning hole (b) is align with the hole in the drawbar bracket.
- Install the ring and pin.

- Install the ring and pin to secure the drawbar to the drawbar bracket.

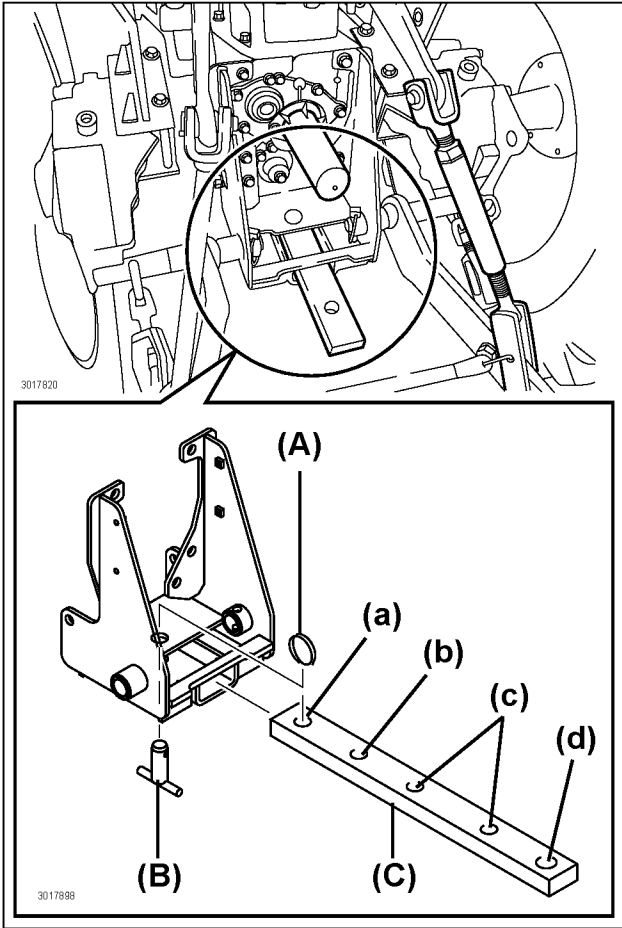

- (A) Ring
 (B) Pin
 (C) Drawbar
 (a) Hole for attaching the drawbar in the operating state (deployed position).
 (b) Hole used when the drawbar is stowed in the tractor (do not use this hole for drawbar in the operating state).
 (c) Hole for attaching an implement.
 (d) Hole for most pulled away position.

■ Remove Drawbar

- Remove the ring.
- Remove the pin.
- Remove the drawbar.
- Install the pin to the drawbar.
- Install the ring.
- Keep the drawbar to the storage area.

3. Use the Safety Chain

⚠ WARNING

Avoid injury!

- Always hitch loads being towed to the drawbar.
- The preceding action prevents the tractor from tipping over to the rear.
- Never use the safety chain alone to tow a load.

IMPORTANT

- Always secure the towed implement to the drawbar.
 - the safety chain is only intended to control the towed implement if the towed implement is accidentally disconnected from the drawbar
- Always use a chain whose strength is rated greater than the gross weight of the towed implement.
- Always replace or repair the safety chain if any of the chain link/s or connector/s is/are broken, elongated or damaged.

- Use the appropriate adapter parts to connect the safety chain to the tractor drawbar support and to the towed implement.
 - Allow enough slack in the safety chain to enable turning.
- As necessary, mount additional intermediate support for the safety chain on the drawbar to eliminate excessive slack.
 - Remove and store the safety chain when not in use.

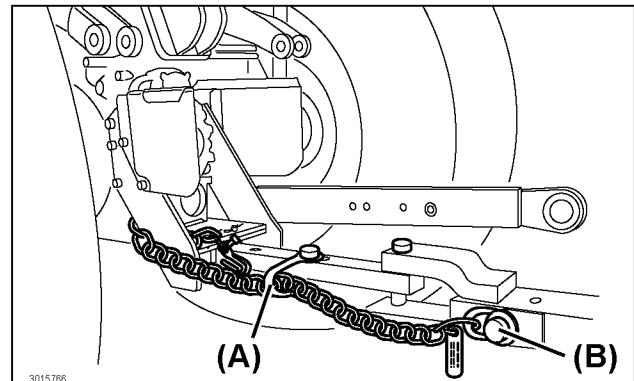

- (A) Intermediate support
 (B) Towed implement attachment point

IMPORTANT

- For safety purposes, ensure that any implements or trailer towed by the tractor drawbar is equipped with a safety chain.
 - the chain holds the implement when the implement is accidentally disconnected from the tractor
- Make sure that the tensile strength of the chain is greater than the weight of the implement, or that of the fully loaded trailer.
- A chain shackle whose strength is the same or is greater than that of the safety chain can be added to the tractor drawbar bracket where the safety chain (of the implement or trailer) can be connected.
- For additional safety, install a chain shackle to the drawbar bracket.

11. HYDRAULIC SYSTEM

WARNING



- Always completely release the internal hydraulic pressure before disconnecting a hydraulic line.
- Always ensure that all connections are securely tightened.
- Always ensure that all hydraulic lines, pipes and hoses are free from wear and/or damage.

1. 3-point Hitch Control System

IMPORTANT

- Avoid operating the 3-point hitch control lever before the engine has been sufficiently warmed up.
- Operating the 3-point hitch control lever while the engine has not yet been sufficiently warmed up:
 - can damage the hydraulic system
 - can result in the complete failure of the hydraulic system
- If abnormal noise occurs after the 3-point hitch has been raised, incorrect adjustment or failure of the hydraulic system are possible causes.
 - immediately stop the operation
 - contact YOUR LOCAL YANMAR TRACTOR DEALER to check and repair the tractor

■ Use the 3-Point Hitch Control Lever

NOTE

- The 3-point hitch delivered with the tractor is a Category 1.

1. Use the 3-point hitch control lever to raise and lower the implement that is attached to the 3-point hitch.

NOTE

- The 3-point hitch control lever is labeled 1 to 9.
- The numbers:
 - for reference purposes only
 - do not indicate any exact height position for the implement that is attached to the 3-point hitch
- The lower the number, the closer the lower links is to the ground.

2. Adjust the position stop knob to set the implement to the lowest possible height.

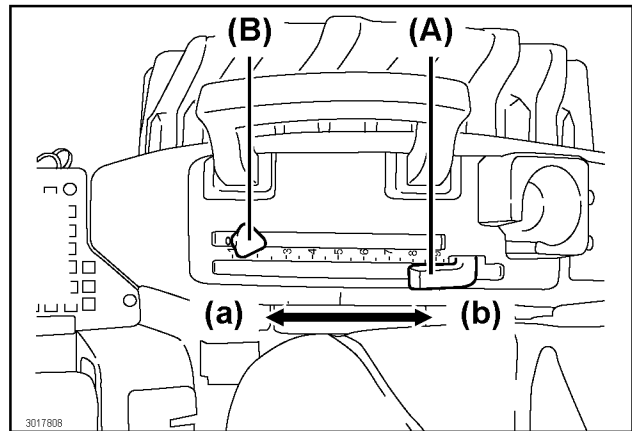

(A) 3-point hitch control lever

(B) Position stop knob

(a) Moving the 3-point hitch control lever forward lowers the implement.

(b) Moving the 3-point hitch control lever backward raises the implement.

■ Use the Position Stop Knob

NOTE

Use the position stop knob to:

- Limit the downward movement of the lower links.
- Set a minimum distance between the attached implements and the ground.

1. Operate the attached implement.
2. Use the 3-point hitch control lever to establish the desired working height (distance from the ground) of the implement.
3. Loosen the position stop knob.
4. Move the position stop knob rearwards until position stop knob stops against the 3-point hitch control lever.
5. Tighten the position stop knob to fix on that particular position.
 - Every time the 3-point hitch control lever stops against the position stop knob, the implement is lowered to the established working height.

■ Hydraulic Flow Control/Stop Knob

WARNING

- Lowering the 3-point hitch too fast can lead to accident or tractor failure.
- Adjust the hydraulic flow control/stop knob:
 - the time for lowering the implement from the highest position to the lowest position, is 2 seconds or longer
- Do not attempt to operate an implement on a road.
- While the tractor is traveling:
 - keep the 3-point hitch control lever in the raised position
 - lock the 3-point hitch control lever with the position stop knob
 - do not fully close the hydraulic flow control/stop knob
 - closing the hydraulic flow control/stop knob can cause damage to the hydraulic lift circuit
- During maintenance:
 - do not use the hydraulic flow control/stop knob as a means to keep the implements raised
 - loss of hydraulic pressure may cause the implement to suddenly drop
 - set the implement on solid blocks, or remove the implement before starting any maintenance
- The hydraulic flow control/stop knob determines the speed at which the lower link is lowered.

IMPORTANT: Avoid damage!

- Avoid attaching a heavy load to the 3-point hitch when traveling on rough terrain.
 - the hydraulic system may be damaged
- Do not operate the 3-point hitch control lever when the hydraulic flow control/stop knob is closed.
 - the preceding action can cause the transmission hydraulic oil to overheat

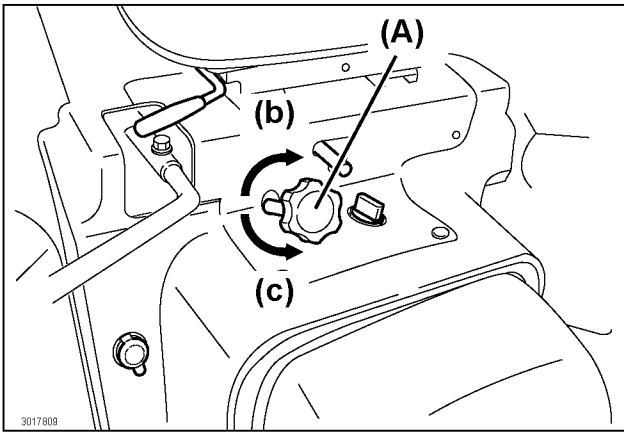

(A) Hydraulic flow control/stop knob

- (a) Knob turned counterclockwise:
- increases the rate of drop speed
 - unlocks the hydraulic lift
- (b) Knob turned clockwise:
- decreases the rate of drop speed
- Knob turned clockwise until the knob stops turning:
- locks the hydraulic lift

2. Operate the Implement Control Valve

■ Implement Control Lever

1. Use the implement control lever to operate the optional mounted implements.

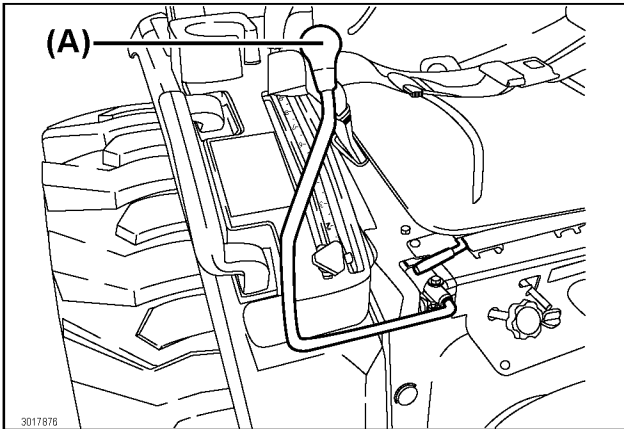

(A) Implement control lever

2. There are 4 hydraulic quick couplers (color coded by the rubber plugs).
 - The hydraulic quick couplers are located under the right foot deck.
 - The hydraulic quick couplers are used to connect the tractor's hydraulics to the implement's hydraulic cylinders.
3. Use the hydraulic quick couplers in pairs: 1 & 2 and 3 & 4.

4. After the couplers and hydraulic lines have been connected, the attached implement moves in a direction opposite to the expected direction:
 - Interchange the hydraulic line connections between couplers 1 & 2.
 - Interchange the hydraulic line connections between couplers 3 & 4.

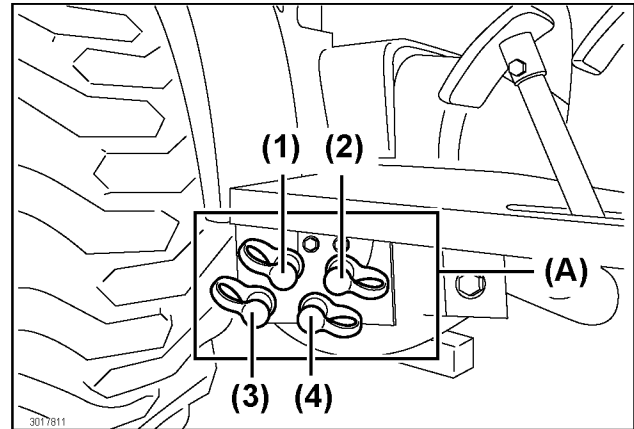

(A) Hydraulic quick couplers

- (1) Blue
- (2) Green
- (3) Red
- (4) Yellow

IMPORTANT

- Avoid interchanging the hydraulic lines between coupler 1 and coupler 3. Contact YOUR LOCAL YANMAR TRACTOR DEALER for technical assistance.
- Avoid interchanging hydraulic lines between coupler 2 and coupler 4. Contact YOUR LOCAL YANMAR TRACTOR DEALER for technical assistance.
- When the hydraulic quick couplers are not used, always leave the color coded rubber plugs inserted to the hydraulic quick couplers.
 - the preceding action prevents damage and contamination of the female hydraulic quick couplers

NOTE

- The implement control valve has a float position.
- When the implement control valve is in the float position, the implement that is lowered to the operating positions follow the ground contour.
 - to use the float position, push the implement control lever forward beyond the valve detent position

NOTE

- Read the *Operator's Manual* and installed label on the tractor side regarding the different implement control lever positions.
- When the lever is at any corner position, the boom and bucket cylinders are simultaneously operated.
- Unnumbered position (Raise & Rollback) is not recommended for scooping purpose because an insufficient lift force is obtained.

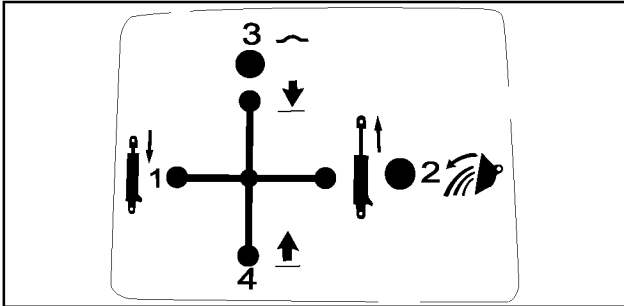

■ Implement Control Lever Lock

1. Use the Implement control lever lock to lock the implement control lever to the N (neutral) position.
2. To lock the implement control lever:
 - Move the implement control lever to N (neutral) position.
 - Move the implement control lever lock slightly to the left and pull up.
 - implement control lever lock moves automatically to the right to lock position
3. To unlock the implement control lever:
 - Move the implement control lever lock slightly to the left and push down.

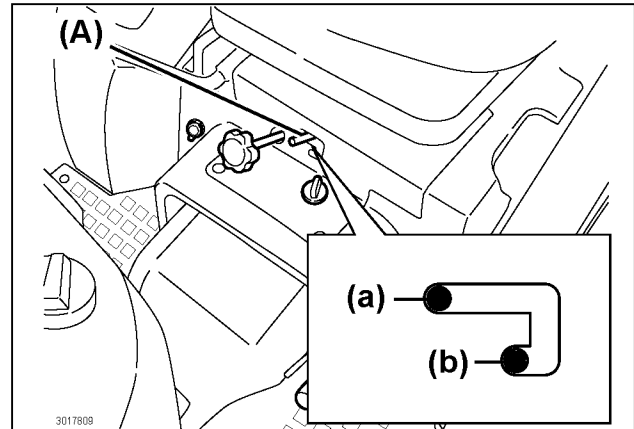

(A) Implement control lever lock
 (a) Lock position
 (b) Unlock position

IMPORTANT

- Avoid operating the implement control lever when the implement control lever is locked.
- To confirm that the implement control lever has been locked with the implement control lever lock:
 - move the implement control lever with a light force to ensure that the lever is securely locked

■ Connect the Implement Hydraulic Hoses

⚠ WARNING

Avoid injury!

- **Avoid connecting the hoses to the hydraulic quick couplers before the hydraulic system pressure has been fully relieved.**
- **When checking for leaks, run a piece of cardboard or wood block along the hydraulic lines and connections.**
- **Avoid getting in contact with high pressure transmission hydraulic oil.**
 - **pressurized transmission hydraulic oil can:**
 - **penetrate the skin and other body parts**
 - **cause serious injury**
- **Immediately see a doctor if transmission hydraulic oil penetrates the skin or other body parts.**
 - **transmission hydraulic oil must be surgically removed**
 - **gangrene may develop**

1. Park the tractor safely and securely.
 - For details, see "7. Safe Practices for Parking the Tractor" on page 1-7.
2. Chock all the tires safely and securely.
3. Fully relieve the hydraulic pressure:
 - By moving the implement control lever forward, backward, right and left several times.
4. For the procedure on connecting the hydraulic hoses to the hydraulic quick couplers, read the implement *Operator's Manual*.

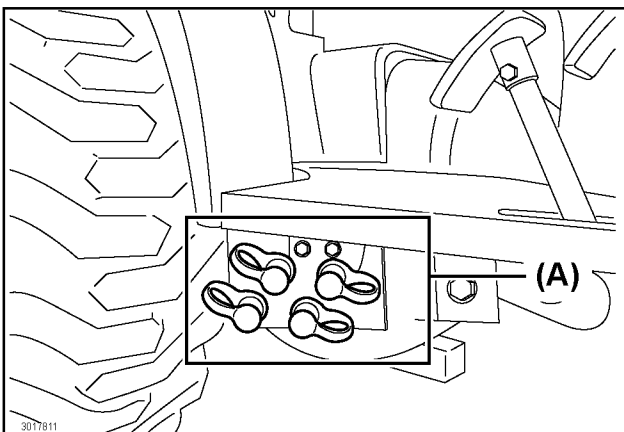

(A) Hydraulic quick couplers

NOTE

- Insert the rubber plug into an unused coupler.

■ Disable the "Regen" Function of the Implement Control Valve

NOTE

- Some optional mounted implements do not require the "regen" function on the implement control valve. In the preceding case, "regen" position can be disabled.

1. Park the tractor safely and securely.
 - For details, see "7. Safe Practices for Parking the Tractor" on page 1-7.
2. Chock the front tires.
3. Remove the right rear tire.
 - For details, see "Chapter 12. TIRES, WHEELS AND WEIGHT" on page 12-1.

NOTE

- The L-shaped bracket can be removed and installed without removing the seat housing cover and the right fender.
- For pictorial clarity and better accessibility, the pictures below were taken with the seat housing cover and the right fender removed from the tractor.

4. Move the implement control lever to the curl position to gain better accessibility to the hairpin clip.
 - Keep the implement control lever in the curl position during the removal and installation of the L-shaped bracket and the hairpin clip.

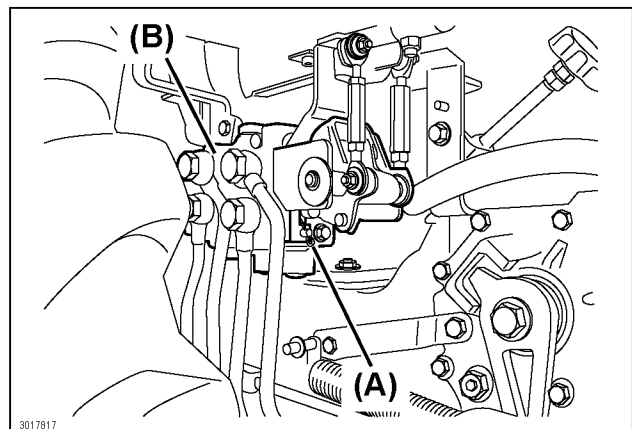

(A) Hairpin clip
(B) Implement control valve

11. HYDRAULIC SYSTEM

5. Remove the hairpin clip in front of the L-shaped bracket.

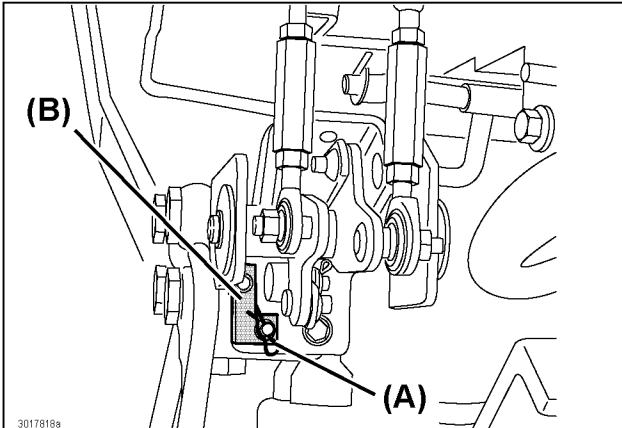

(A) Hairpin clip
(B) L-shaped bracket

6. Pull the L-shaped bracket to remove from the implement control valve.
7. Rotate the L-shaped bracket by 180 degrees both vertically and horizontally to change the orientation.
8. Install the rotated L-shaped bracket back to the implement control valve.

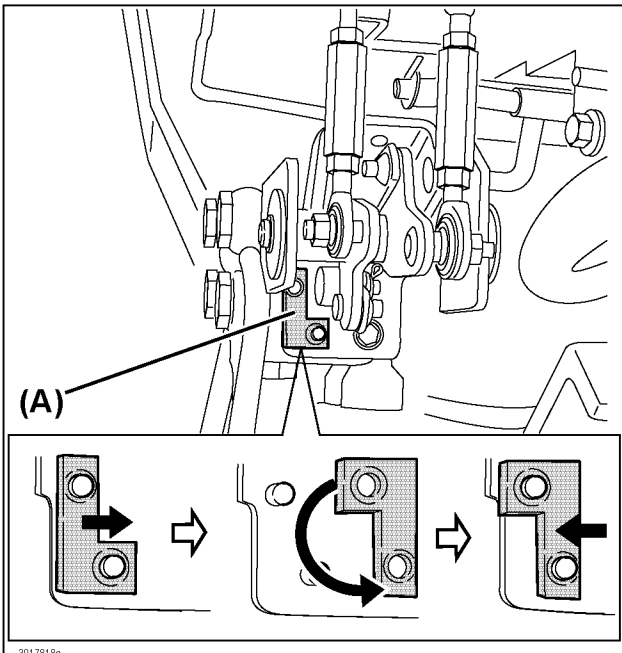

(A) L-shaped bracket

9. Insert the hairpin clip to fasten the L-shaped bracket to the implement control valve.

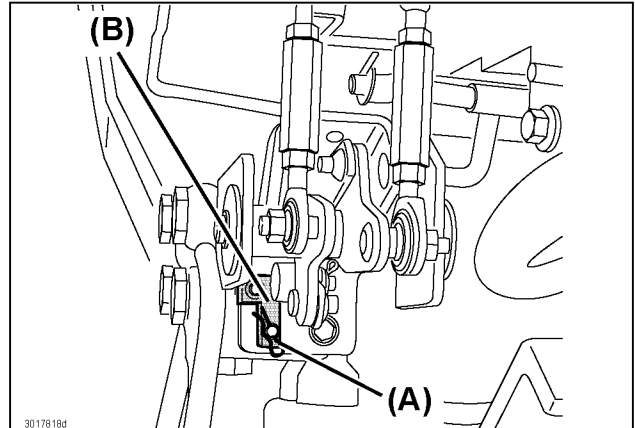

(A) Hairpin clip
(B) L-shaped bracket

10. The "regen" function of the implement control valve is now disabled.
11. Install the right rear wheel.

12. TIRES, WHEELS AND WEIGHT

⚠ WARNING

- Avoid mounting a tire on a rim by an unauthorized person.
 - Always have an authorized professional with the proper equipment mount the tire on the rim.
-
- Always inflate tires to the correct tire air pressure.
 - Avoid exceeding the recommended tire air pressure specified in the *Operator's Manual*.
-
- Always keep the tractor securely supported while:
 - changing the wheels
 - adjusting the tire tread width
-
- Always keep the wheel bolts tightened to the specified torque.
 - Avoid operating the tractor with loose wheels, rims, weights and axles.

1. Tires

⚠ WARNING

Avoid injury!

- Avoid mounting a tire on a rim by an unauthorized person.
- Always have an authorized professional with the proper equipment mount the tire on the rim.
- Always inflate tires to the correct tire air pressure.
- Avoid exceeding the recommended tire air pressure specified in the *Operator's Manual*.

IMPORTANT

- Only use the tires approved by Yanmar tractor dealers.
- Always install the same tires types in the front wheels and the rear wheels (e.g., R3 front and R3 rear, or R4 front and R4 rear).

	Tire Size	Tire Air Pressure (maximum) psi (kPa)	
		Without front mounted implements or ballast	With front mounted implements or ballast
Front	R3: 24 × 8.50-14 4PR	22 (152)	22 (152)
	R4: 23 × 8.50-12	35 (241)	35 (241)
Rear	R3: 36 × 14-15 4PR	20 (138)	20 (138)
	R4: 14-17.5	30 (207)	30 (207)

- 2 tire sizes are provided for the front wheels.
- Another 2 tire sizes are provided for the rear wheels.
- The recommended tire air pressures for the tires are as specified in the table above.
- The tire air pressure gradually decreases as the tires are used and as time elapses.
- Check the tire air pressure before starting the day's operation.
- When the tire air pressure is low, inflate the tires to the recommended tire air pressures.

- If the tire air pressures rapidly and significantly decrease though the tires are correctly inflated every day, immediately contact YOUR LOCAL YANMAR TRACTOR DEALER to inspect the problem tire/s and to replace the tire/s if necessary.

NOTE

- While a loader is mounted to the tractor, always set the front tire air pressure to the maximum recommended tire air pressure.
- The above also applies while the tractor is fitted with a full load of front weights.
- Do not use dual tires.

2. Adjust the Wheel

⚠ WARNING

Avoid injury!

- Before working under the tractor or an implement, always lower to the ground all attached implement.
- During work under the tractor or an implement, always use proper and rigid lifting devices with the capacity of more than 3 tons.
- Always support the implement using fixed stands or any suitable blocking devices with a capacity of more than 3 tons.
- While servicing or adjusting the tractor and implement, avoid using the hydraulic system to keep the tractor and implement in the position.
- Avoid operating the tractor with loose wheels, rims, weights and axles.
- Avoid changing the specific adjustment settings for each tire size.

■ Check the Wheel Bolt Tightening Torque

⚠ WARNING

Avoid injury!

- Before operating the tractor, check that there are no loose rims, hubs, wheel bolts and/or axles.
- The preceding action promotes tractor stability.
 - reduces the possibility of the tractor tipping over
- Tighten all the wheel bolts after every 4 hours of operation.
- Repeat tightening until the proper torque values of the wheel bolts are constantly maintained.
- Perform the preceding procedure when any wheel bolt/s is/are loosen.
- Make sure to maintain the tightness of the wheel bolts according to the recommended maintenance intervals.

Tighten the wheel bolts as follows:

Front Wheel

Tighten the front wheel bolts in a crisscross sequence to 127 to 140 ft•lbs (172 to 190 N•m).

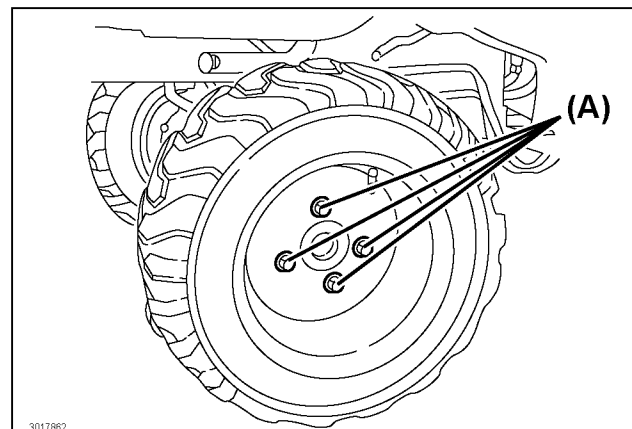

(A) Front wheel bolts

Rear Wheel

Tighten the rear wheel bolts in a crisscross sequence to 80 to 94 ft•lbs (108 to 127 N•m).

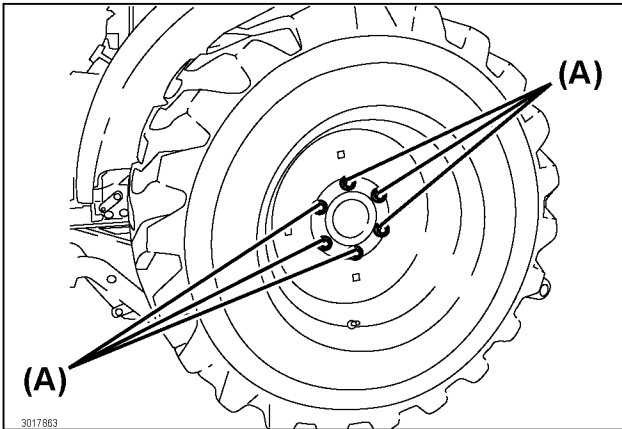

(A) Rear wheel bolts

■ Select the Front Tire Rolling Direction

⚠ WARNING

Avoid injury!

- Wheels are heavy or difficult to handle during removal.
- Be very careful when attempting to remove wheels from the tractor.
- Use a safe lifting device with a capacity of more than 3 tons.
- Securely support the tractor with rigid stands or jack stands with a capacity of more than 3 tons.
- Make sure to chock all the tires safely and securely which are still in contact with the ground.
- The preceding procedure prevents the tractor from rolling.
- Directional type tires, such as bar tires, have directional arrows on the sidewall.
- Install the tires with the directional arrows pointing in the rolling direction.
- If the tractor is mostly used for loader operations, periodically reverse the tread pattern direction.
 - the preceding procedure increases the tire life and improves traction when reversing from dirt piles

■ Change the Tire Tread Width

⚠ WARNING

Avoid injury!

- When working on a slope, always use the tractor with the rear wheels mounted in the wide tire tread width position. The preceding practice increases stability.
- Exercise caution when removing wheels.
- Wheels are heavy and difficult to handle.
- Use a safe lifting device with a capacity of more than 3 tons.
- Securely support the tractor with rigid stands or jack stands with a capacity of more than 3 tons.
- Make sure to chock all the tires safely and securely which are still in contact with the ground.
- The preceding procedure prevents the tractor from rolling.

IMPORTANT

- For maximum forward traction, always ensure that the arrows on the tire sidewall point in the rolling direction.

NOTE

- The tire tread width is measured from centerline to centerline of each tire.

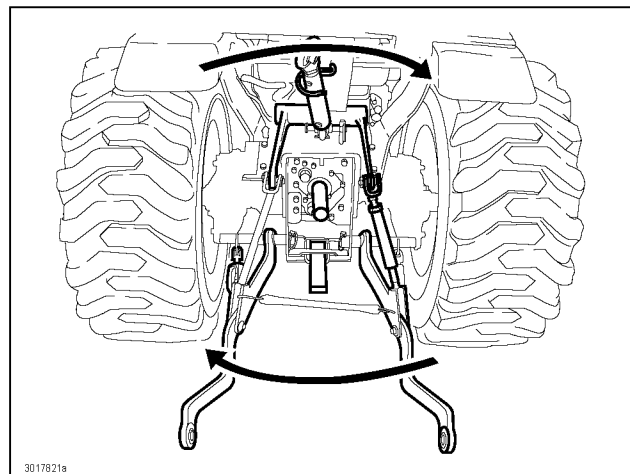

Interchange the wheels located on both sides of the tractor.

3. Remove/Install the Wheels

WARNING

Avoid injury!

- Wheels are heavy or difficult to handle during removal.
- Be very careful when attempting to remove wheels from the tractor.
- Use a safe lifting device with a capacity of more than 3 tons.
- Securely support the tractor with rigid stands or jack stands with a capacity of more than 3 tons.
- Make sure to chock all the tires safely and securely which are still in contact with the ground.
- The preceding procedure prevents the tractor from rolling.

4. Weight (Option)

IMPORTANT

- Find and read the maximum load information embossed into the sidewall of each tire.
- Make sure that tires are not subjected to loads that exceed the information.
- If the maximum weight shown on the chart is not enough to ensure safety, reduce the load or use higher tire ply rating.
- Remove the weights from the tractor when no longer needed.
- Always avoid adding weight when performing continuous and full power operations at a speed of above 4.4 mph (7 km/h).
- The preceding practice:
 - prevents excessive soil compaction
 - prevents resistance to wheel rotation
 - extends the drive train life

WARNING

Avoid injury!

- If there is a danger that the tractor becomes unstable when implement is used, add weight on the tractor.
- The preceding precaution is particularly necessary when an implement is raised.
- Always drive slowly over rough terrain, regardless of how much weight is used.
- Implement and tractor components are heavy.
- Always use proper lifting devices with a capacity of more than 3 tons.
- Always have assistance from another person when installing or removing any implement.
- Exercise the preceding caution while installing or removing components of the tractor.

12. TIRES, WHEELS AND WEIGHT

■ Select the Appropriate Amount of Front Weight

Maximum Load Per Front Tire		
Tire Size	Ply Rating	Capacity lb. (kg)
R3: 24 × 8.50-14 4PR	4	558 (253)
R4: 23 × 8.50-12	6	667 (303)

- Heavy pulling can cause the front wheels to lift off the ground.
- Heavy rear mounted implement can cause the front wheels to lift off the ground.
- As required, add weight to the front end of the tractor to make the tractor stable.
- Add just enough weight to prevent the tractor from tipping over.
- Make sure that steering control is still maintained.
- Make sure to remove all weights when no longer required.
- Use the chart above to determine the maximum load capacity of each front tire, at maximum allowed tire air pressure.

■ Front Weights (option)

As necessary; (optional) front weights can be installed on the front weight mounting bracket.

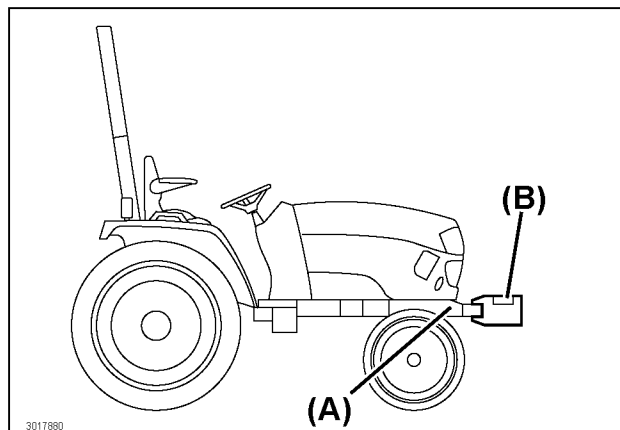

(A) Mounting bracket
(B) Front weights (option)

The number of weights required for each implement type is shown in the table.

NOTE

- The front weight mounting bracket is an integral part of the tractor front end frame.
- The maximum of 44 lb. (20 kg) × 4 pieces front weights can be mounted.

Required number of front weights when mounting a Yanmar implements	
Implement Name	Number of Weights
Tiller RT66	0
Box Scraper BS60	0
Rear Blade RB60	0
Landscape Rake LR60	0
Rotary Cutter RC60	3
Finish Mower FM48	0
Backhoe CB65	0

12. TIRES, WHEELS AND WEIGHT

■ Select the Appropriate Amount of Rear Weight

- Operation of front mounted implement such as a loader can cause the rear wheels to lift off the ground.
- As required, add weight to the rear end of the tractor to make the tractor stable.
- Use of the optional rear ballast is best suited for the loader operations.
- Make sure to remove all weights when no longer required.
- Use the chart below to determine the maximum load capacity of each rear tire at maximum inflation.

Rear Weight Capacity

Tire Size	Condition	Gross Ballast Box Weight lb. (kg)
R3	With Liquid Weight	234 (106)
	Without Liquid Weight	530 (240)
R4	With Liquid Weight	263 (119)
	Without Liquid Weight	486 (220)

⚠ WARNING

Avoid injury!

- Always use a lower load on the tires than the indicated maximum capacity.
- Always keep the amount of rear weight within the limits indicated below.

Maximum Load Per Rear Tire

Tire Size	Ply Rating	Capacity lb. (kg)
R3: 36 × 14-15 4PR	4	1179 (535)
R4: 14-17.5	6	2185 (991)

For information regarding the rear weight, for details, see "Use Liquid Weight for the Tires" on page 12-7.

■ Use the Optional Rear Wheel Weights

Optional cast iron rear wheel weights are available from YOUR LOCAL YANMAR TRACTOR DEALER.

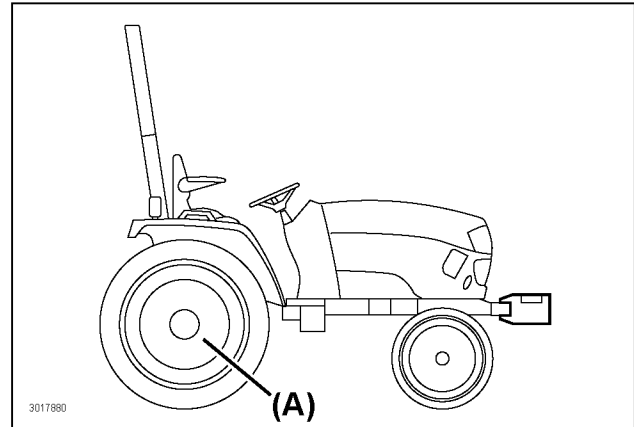

(A) Rear wheel weights

IMPORTANT

- Always use a lower load on the tires than the indicated maximum capacity.

Max. allowable weight per side	180 lb. (82 kg)
--------------------------------	-----------------

1. Adjust the rear tire tread width to the wide position to improve stability.

⚠ WARNING

Avoid injury!

- Handle weights with care!
- Use a safe and appropriate lifting device with a capacity of more than 3 tons.
- Have the procedure performed by YOUR LOCAL YANMAR TRACTOR DEALER.

12. TIRES, WHEELS AND WEIGHT

■ Use the Optional Rear Ballast

Optional rear ballast for carrying weights on the 3-point hitch is available from YOUR LOCAL YANMAR TRACTOR DEALER.

The amount of weight needed in the rear ballast for the proper operation of a front mounted implement can be found on the *Operator's Manual*.

⚠ WARNING

Avoid injury!

- Use of the optional rear ballast is recommended.
- The preceding action improves the stability of the loader.
- Use weight as per the recommendation contained in the loader *Operator's Manual*.

IMPORTANT

- Always put a lower load on the tires than the indicated maximum capacity.

■ Use Liquid Weight for the Tires

⚠ WARNING

Avoid injury!

- Installation of tire liquid weight requires special equipment and training.
- An exploding tire can lead to injury.
- Contact YOUR LOCAL YANMAR TRACTOR DEALER for technical assistance.

IMPORTANT

- Always use a lower load on the tires than the indicated maximum capacity.
- Always fill the tire with the liquid above the rim level to prevent corrosion:
 - avoid exceeding 75% of the tire's internal space
- The preceding condition:
 - the tire is less capable of absorbing shock
 - the tire has a shorter useful lifetime

NOTE

- Avoid using alcohol as weight.
- Calcium chloride solution is heavier.
- A water solution of calcium chloride is a safe weight.
- The preceding solution prevents freezing and does not damage the tires, tubes or rims.
- Mix a solution of 3.5 lb. (1.6 kg) of calcium chloride and approximately 4 qt. (3.8L) of water.
- The solution mentioned in the preceding does not freeze at a temperature of above -50 °F (-45 °C).
- Fill the tubeless tires at least up to the valve stem height (at least 75% filled) (A).
- A smaller amount of the solution results in partly exposed rims:
 - can lead to corrosion of the rim

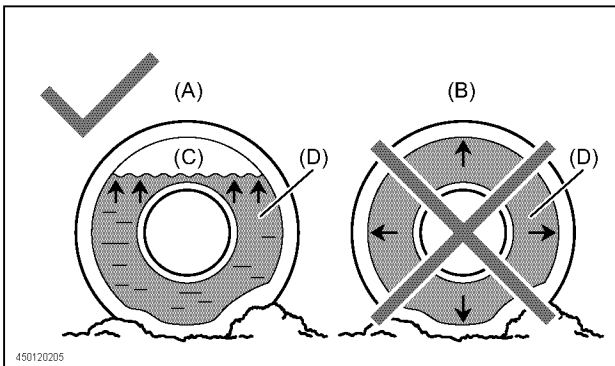

- (A) Correct: 75% full: The remaining air can be compressed like a cushion.
 (B) Incorrect: 100% full: Water cannot be compressed.
 (C) Air
 (D) Water/calcium chloride solution

Liquid Weight per Tire (75% filled)

Tire Sizes	R3	R4
No slush at 14°F (-10°C) Solid at -22°F (-30°C) [Add approx. 2.2 lb. (1 kg) CaCl ₂ per 4 qt. (3.8 L) of water]	261.4 lb. (115.0 kg)	178.6 lb. (81.1 kg)
No slush at -11°F (-24°C) Solid at -22°F (-30°C) [Add approx. 3.3 lb. (1.5 kg) CaCl ₂ per 4 qt. (3.8 L) of water]	279.5 lb. (126.9 kg)	197.1 lb. (89.5 kg)
No slush at -52°F (-47°C) Solid at -62°F (-52°C) [Add approx. 5 lb. (2.25 kg) CaCl ₂ per 4 qt. (3.8 L) of water]	319.8 lb. (145.2 kg)	225.3 lb. (102.3 kg)

13. MAINTENANCE

- For each of the checkpoints listed below, check and service at the intervals indicated in the table.
- For the inspection and maintenance procedures, for details, see "Chapter 14. PERIODIC SERVICE" on page 14-1.

1. Maintenance Check List

No	Topic	Time	Service Intervals																After purchase						
			Daily	If Necessary	Hours														1 year	2 years					
					50	100	150	200	250	300	350	400	450	500	550	600	800	1000							
1	Engine Oil Level	Check	Daily	✓																					
2	Transmission Hydraulic Oil Level	Check	Daily	✓																					
3	Tire Air Pressure	Check	Daily	✓																					
5	Fuel Tank	Check	Daily	✓																					
		Refill																							
6	Rubber Dust Unloading Valve	Clean	Daily	✓																					
7	Radiator Hose and Clamp	Check	Daily	✓																					
		Replace	Every 2 years																				✓		
8	Radiator Cooling Screen	Clean	Daily	✓																					
9	Safety Systems	Check	Daily	✓																					
10	Radiator Cooling Fins	Clean	Daily	✓																					
11	Cooling System	Check	Daily	✓																					
		Flush	Every 2 years or after 1000hr																				✓	✓	
12	Coolant	Change	Every 2 years or after 1000hr																				✓	✓	
13	Fuel Line	Check	Daily	✓																					
		Replace	Every 2 years																						✓
14	Power Steering Line	Check	Daily	✓																					
		Replace	Every 2 years or if necessary		✓																				✓
15	Retractable Seatbelt	Check	Daily	✓																					
		Replace	If necessary		✓																				
16	Roll-Over Protective Structure (ROPS)	Check	Daily	✓																					
		Replace	If necessary		✓																				
17	Headlights, Hazard Lights, and all other lights (lights and/or bulbs).	Check	Daily	✓																					
		Replace	If necessary		✓																				
18	Alternator/fan Belt	Inspect	Daily	✓																					
		Adjust	Every 50hr or if necessary		✓	✓	✓	✓	✓	✓	✓	✓	✓	✓	✓	✓	✓	✓	✓	✓					
		Replace	First 50hr, then if necessary		✓	✓																			
19	Transmission Hydraulic Oil Strainer	Clean	50/300hr and every 300hr after			✓				✓											✓				
20	Air Cleaner Element	Clean	Every 100hr or if necessary		✓		✓		✓		✓		✓		✓		✓		✓	✓	✓				
		Replace	Every 1 year or if necessary		✓																		✓	✓	

13. MAINTENANCE

No	Topic	Time	Service Intervals																	After purchase					
			Daily	If Necessary	Hours															1 year	2 years				
					50	100	150	200	250	300	350	400	450	500	550	600	800	1000							
21	Fuses	Check	Daily	✓																					
		Replace	If necessary		✓																				
22	Battery Condition	Check	Daily	✓																					
23	Battery	Replace	If necessary		✓																			✓	
24	Fuel Filter	Replace	Every 500hr or if necessary	✓																			✓		
25	Fuel/Water Separator	Drain	Every 50hr or if necessary	✓	✓	✓	✓	✓	✓	✓	✓	✓	✓	✓	✓	✓	✓	✓	✓	✓	✓	✓			
		Clean	Every 100hr or if necessary	✓		✓		✓		✓		✓		✓		✓		✓		✓		✓			
		Replace	Every 100hr or if necessary	✓		✓		✓		✓		✓		✓		✓		✓		✓		✓			
26	Wheel Bolt Tightening Torque	Check	Daily	✓																					
27	Engine Oil	Change	50/200hr and every 200hr after		✓			✓				✓					✓		✓	✓	✓				
28	Engine Oil Filter	Replace	50/200hr and every 200hr after		✓			✓				✓					✓		✓	✓	✓				
29	Transmission Hydraulic Oil	Change	50/300hr and every 300hr after		✓						✓						✓								
30	Hydraulic Filter	Replace	50/300hr and every 300hr after		✓						✓						✓								
31	Grease fittings	-	Every 50hr after		✓	✓	✓	✓	✓	✓	✓	✓	✓	✓	✓	✓	✓	✓	✓	✓	✓	✓	✓		
32	Toe-in	Inspect/Adjust	50/200hr and every 200hr after		✓			✓				✓					✓		✓	✓	✓				
33	Front Axle Pivot	Check	Every 50hr		✓	✓	✓	✓	✓	✓	✓	✓	✓	✓	✓	✓	✓	✓	✓	✓	✓	✓			
34	Air Intake Hoses and Clamps	Check	50/200hr and every 200hr after		✓			✓				✓					✓		✓	✓	✓				
		Replace	Every 2 years or if necessary																					✓	
35	Front Axle Gear Oil	Check	Every 50hr		✓	✓	✓	✓	✓	✓	✓	✓	✓	✓	✓	✓	✓	✓	✓	✓	✓	✓			
		Change	Every 500hr															✓					✓		
36	Brake	Check	Daily	✓																					
		Adjust	Every 500hr																	✓					
		Replace	If necessary		✓																				
37	Engine Valve Clearance	Adjust	Every 1000hr																			✓			
38	Fuel Injection Pump	Check	Every 1000hr																				✓		
39	Fuel Injection Nozzle	Check	Every 1000hr																				✓		
40	Thermostat	Replace	Every 2 years or 2000hr after																					✓	

For assistance in periodic maintenance procedures, contact YOUR LOCAL YANMAR TRACTOR DEALER.

NOTE
 ● Check the wheel bolt tightening torque after one hour of break-in.

2. Diesel Fuel Specifications

In consistency with other global diesel engine manufacturers and diesel fuel injection equipment manufacturers, Yanmar encourages the development of renewable compression ignition fuels and wishes to clarify our position on the use of biodiesel fuels in Yanmar Industrial Engines.

In United States, non-mineral oil based fuel resources such as RME (Rapeseed Methyl Ester) and SOME (Soybean Methyl Ester), collectively known as FAME (Fatty Acid Methyl Esters), are being used as extenders for mineral oil derived diesel fuels.

After Yanmar conducted the applicability evaluation, Yanmar approves the use of B7 (up to 7% FAME) Diesel which shall not exceed a blend of 7% (by volume) of FAME with 93% (by volume) of approved mineral oil derived diesel fuel in Yanmar Industrial Engines.

Yanmar's limited warranty conditions in case certain engines manufactured by Yanmar are operated with B7 Diesel are as follows:

1. Yanmar accepts the use of B7 Diesel only on the conditions that:
 - B7 Diesel must comply with "the American Standard ASTM D-6751 and ASTM D-7467(for Oxidation stability)" if you and/or your clients are located in the US.
 - Replacement of the following parts before using the recommended biodiesel:
 - 1A7540-04250 Hose Kit, Fuel
2. Please purchase B7 Diesel only from recognized and authorized diesel fuel suppliers.
3. Please use only B7 Diesel including methanol as the above relevant regulations state; otherwise, it may cause corrosion in aluminum and zinc fuel injection equipment components.
4. Please use only B7 Diesel contained certain water level as the above relevant regulations state; otherwise, it may cause fuel filters plugged and also may increase bacterial growth.
5. Please use only B7 Diesel with low viscosity at high temperatures; otherwise, it may cause problems on fuel delivery, injection pump seizures and poor injection nozzle spray atomization.
6. Please check the engine oil level daily. If the oil level rises above the oil level of the previous day, the engine oil needs to be immediately replaced.
7. Please check and confirm the quality of B7 Diesel and other fuel tanks before you will start to use it. Please keep daily maintenance during the use of B7 Diesel and do not forget to regularly flush the fuel system and fuel storage containers. You may only use B7 Diesel at least within two (2) months from the time of filling the tank or three (3) months from the time of production by the said fuel suppliers, whichever comes first.

Yanmar does not warrant and is not responsible for any problems caused by the use of the deteriorated B7 Diesel or by the use of the B7 Diesel which do not comply with the above relevant regulations.

3. Lubricants

No.	Locations	Capacities	Lubricants	
1	Fuel	Approximately 7.1 US gal (27 L)	No.2-D diesel fuel No.1-D diesel fuel if temperature is below 14°F (-10°C)	
2	Coolant*	Approximately 4 qt. (3.9 L)	High Quality Permanent Type Antifreeze (Ethylene Glycol with corrosion and rust inhibitor chemicals) Coolant Mixture Ratio Distilled Water 50%: Antifreeze 50%	
3	Engine crankcase (with filter)	Approximately 3.9 qt. (3.6 L)	API Service Classifications CF or higher SAE 10W-30 or SAE 10W-40	
4	Transmission hydraulic oil	Approximately 4.6 US gal (17.5 L)	Hydraulic/Transmission Fluid (TF 500)	
5	Front axle case	Approximately 1.03 US gal (3.9 L)	SAE 80W-90 gear oil	
6	Greasing	No. of greasing points	Lubricants	Type of grease
	Front axle pivot	1	Until grease overflows	General all purpose grease NLGI grade No.2
	Tie-rod end	2		
	Brake pedal shaft	5		
	Top link	1		

(Specifications and design are subject to change without prior notice for improvement.)

***NOTE**

- Immediately after purchasing the tractor:
 - adjust the coolant mixture ratio of the coolant and water to suite the local climate
 - the preceding practice assists in making the tractor function efficiently
- The coolant can remain unchanged for a period of 2 years:
 - if during the period the tractor is operated for less than 1200 hours
 - if the tractor is operated for more than 1200 hours during the period, the coolant has to be replaced during flushing of the system
- After pouring the coolant, run the engine for a short period to mix the two fluids thoroughly.

4. Replacement Parts

■ Technical Document

For a copy of the Illustrated Parts List or the Technical Manual of the tractor, contact YOUR LOCAL YANMAR TRACTOR DEALER.

■ Parts

Use Yanmar lubricants available from YOUR LOCAL YANMAR TRACTOR DEALER.

NOTE

- Only use the Yanmar genuine parts. Non-genuine parts can cause serious damage and accidents.

When ordering a part, tell YOUR LOCAL YANMAR TRACTOR DEALER the tractor serial number and engine serial number. For details, see "Chapter 2. SERVICE THE TRACTOR" on page 2-1.

Part Numbers

Item	Part Number
Engine Oil Filter	129150-35153
Hydraulic Oil Filter	198167-24900
Hydraulic Oil Suction Screen Filter	198421-24910
Suction Screen R-Ring	1A870-24980
Air Cleaner Filter	119808-12520
Fuel Filter	119802-55801
Fuel Filter Element	119802-55710
Valve Cover Gasket	129004-11310
Alternator Belt	25152-003700
10 Amp Fuse	198535-52120
15 Amp Fuse	198535-52130
25 Amp Fuse	1A7540-52180
80 Amp Slow Blow Fuse	198153-51700
Battery	1A8160-51500
Headlight Bulb	1A7880-53080
Tail light Bulb	1A8300-53260
Sidelight	194640-54170
2.0W Instrument Panel - Warning Bulb	1A7510-56110
1.4W Instrument Panel - Buck Light Bulb	198448-56150
Warning Lamp Bulb	1A8300-53250

14. PERIODIC SERVICE

WARNING

Explosion Hazard



- Never smoke around the battery.
- Never smoke during refueling.
- Keep sparks and open flames away from the battery and the fuel tank.
- The battery emits hydrogen and oxygen during recharging and can pose a serious hazard.

- Never work under any hydraulically supported devices which can settle down, suddenly leak or be accidentally lowered.
- Always support the tractor securely with rugged jack stands or other suitable lifting device with the capacity of more than 3 tons.
- Always allow the tractor to fully cool down before accessing the:
 - engine, muffler, radiator, and hot components
- Always park the tractor on a solid and level ground.
- Engage the parking brake securely, for details, see "6. Lock and Set the Parking Brake" on page 7-3.
- Push down Power Take Off (PTO) switch to OFF position.
- Lower all the implement to the ground.
- Move the range gear lever to N (neutral) position.
- Shut off the engine.
- Remove the key from the starter key switch before starting any maintenance work.
- Chock all the tires safely and securely.

■ Service the Tractor

IMPORTANT

- Service and maintain the tractor more frequently if the tractor is used in severe conditions.
- Engine components and parts can get dirty or deteriorate on the following condition:
 - the tractor is operated in extreme heat
 - dusty locations
 - severe operating conditions
- The engine oil deteriorates earlier than expected on the following conditions:
 - the tractor is constantly operated at slow or low engine speeds
 - the tractor is used frequently for short durations
 - for details, see "1. Maintenance Check List" on page 13-1

■ Warranty and Repair of the Engine

NOTE

- The maintenance, inspection, repair and replacement services on the engine emission control devices and systems:
 - can be performed at the owner's expense by any qualified off road engine repair shop or mechanic
 - warranty repairs must be executed by an authorized Yanmar tractor dealer

⚠ WARNING

NEVER inhale the engine exhaust gas.



- Read the DANGER, WARNING AND CAUTION statements on the safety alert decals on the tractor.
- Before starting the engine:
 - remain seated on the operator seat
 - move the range gear lever to the N (neutral) position
 - push down Power Take Off (PTO) switch to OFF position
 - never attempt to start the engine while the operator is still on the ground
- Engine exhaust gas contains carbon monoxide.
 - if inhaled, the engine exhaust gas can cause severe poisoning or even death
- Always perform the safety checks in a well ventilated area.
- When working in an enclosed area, always expel the engine exhaust gas to an outdoor area.
 - connect one end of an extension pipe to the engine exhaust pipe
 - set the other end outside of the work area
- Allow fresh outside air to flow into an enclosed work area to remove the engine exhaust gas from the area.

1. Open/Close the Hood

⚠ WARNING

Avoid injury!

- Avoid opening the hood while the engine is running.
- Avoid touching any hot components, e.g., the muffler and the exhaust pipe.

■ Open the Hood

1. Park the tractor safely and securely.
 - For details, see "7. Safe Practices for Parking the Tractor" on page 1-7.
2. Pull the hood release lever upward to unlock the hood latch.

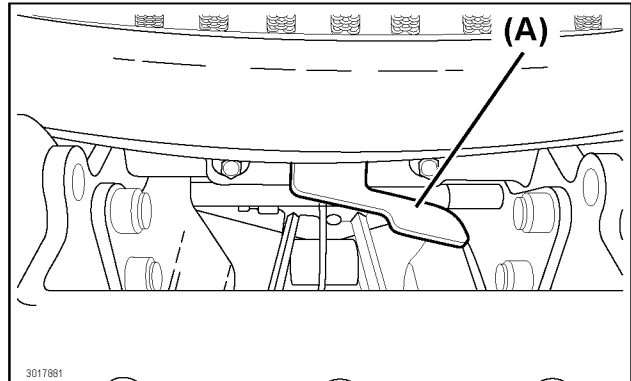

(A) Hood release lever

3. Lift up the hood with both hands.
4. Keep the hood raised with one hand and use the other hand to lock the hood support.
 - Push the lever on the hood support to lock.

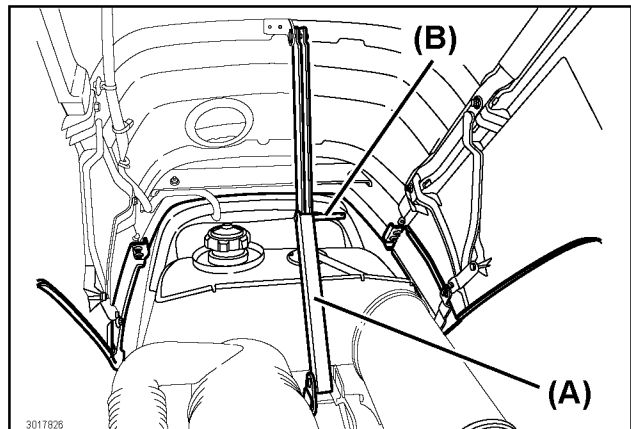

(A) Hood support
(B) Lever

⚠ CAUTION

- Do not get in contact with a raised hood.
- The preceding action can cause the hood support to accidentally unlock.

■ Close the Hood

1. Slightly lift up the hood.
2. Hold the lever at the middle of the hood support.
3. Pull forward the lever to unlock the hood support.
4. Lower the hood.
5. Press down firmly the upper front portion of the hood until the hood latch locks the hood to the closed position.
6. Try to lift the hood to ensure the hood latch has securely locked.

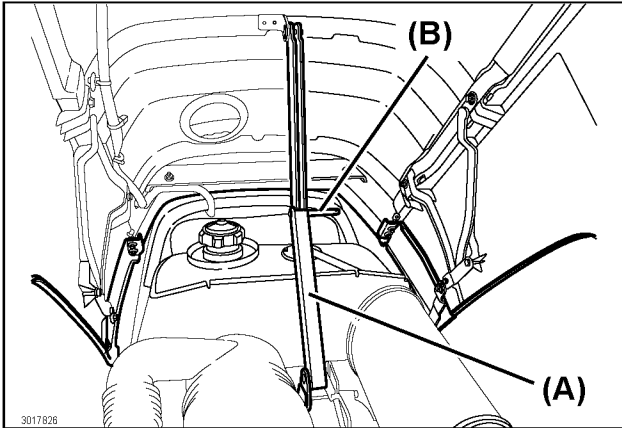

(A) Hood support
(B) Lever

⚠ CAUTION

- When closing the hood, avoid getting finger/s trapped in the hood or hood support.

2. Daily Checks

■ Check the Engine Oil Level

IMPORTANT

- Always check the engine oil level daily.
 - insufficient or no engine oil can cause serious engine problems
- Always check the engine oil level before commencing operations.
- Always check the engine oil level only while the engine is cold and not running.
- Always maintain the engine oil level between the lower and the upper mark.
- Before adding the engine oil, always:
 - shut off the engine
 - allow the engine to cool down for several minutes

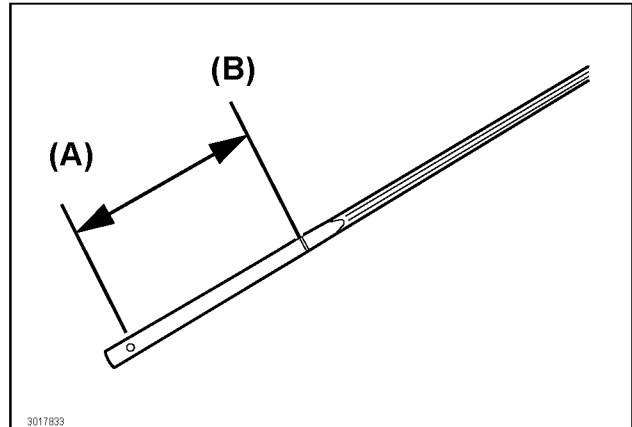

(A) Lower mark
(B) Upper mark

NOTE

- If the engine is used for more than 4 hours in a day:
 - check the engine oil level twice a day
- Make sure that the engine is cold before checking the engine oil level.

14. PERIODIC SERVICE

1. Park the tractor safely and securely.
 - For details, see "7. Safe Practices for Parking the Tractor" on page 1-7.
2. Shut off the engine.
3. Chock all the tires safely and securely.
4. Allow the engine to cool down for several minutes.
5. Raise the hood.

NOTE

- During the checking of the engine oil level:
 - dirt and dust can enter the engine
- Clean the area around the dipstick before removing the dipstick.

6. Remove the dipstick.
7. Clean the dipstick with a clean rag.
8. Insert the dipstick completely.
9. Remove the dipstick again.
10. Read the engine oil level on the dipstick.
11. The engine oil level must be between the upper and lower marks on the dipstick.

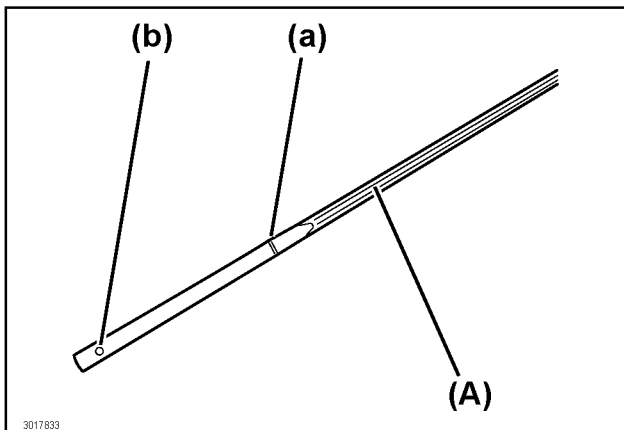

(A) Dipstick
(a) Upper mark
(b) Lower mark

NOTE

If the engine oil level is low:

- Remove the engine oil filler cap.
- Add the specified engine oil until the engine oil level is in the operating range on the dipstick.

NOTICE

- Avoid overfilling the engine with engine oil.

12. If the engine oil exceeds the upper mark level on the dipstick:
 - Drain the engine oil to a proper level.
13. Insert the dipstick to check the engine oil level.
14. Lower the hood.

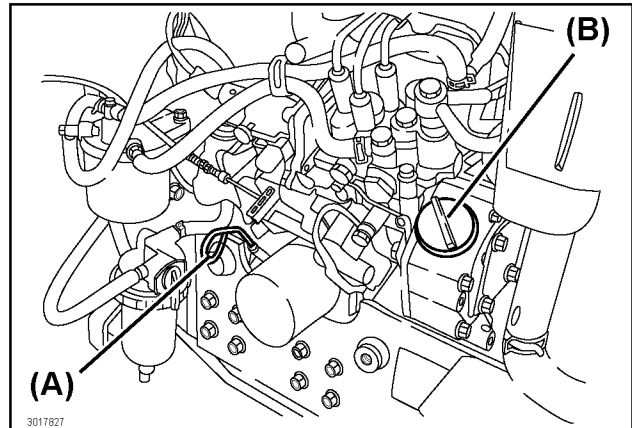

(A) Dipstick
(B) Engine oil filler cap

■ Inspect the Transmission Hydraulic Oil Level

1. Park the tractor safely and securely.
 - For details, see "7. Safe Practices for Parking the Tractor" on page 1-7.
2. Shut off the engine.
3. Chock all the tires safely and securely.
4. Allow the engine to cool down for several minutes.

IMPORTANT

- Before removing transmission hydraulic oil filler cap, carefully clean the area around the transmission hydraulic oil filler cap.
- The preceding action prevents dirt and other contaminants from entering the transmission.
- Avoid overfilling the transmission with transmission hydraulic oil.

5. Read the transmission hydraulic oil level on the sight glass.
 - The transmission hydraulic oil level should be at 3/4 level of the sight glass.

6. When the transmission hydraulic oil level is lower than the 3/4 level:
 - Clean the area around the transmission hydraulic oil filler cap.
 - Remove the transmission hydraulic oil filler cap from the transmission housing.
 - Add transmission hydraulic oil to the appropriate transmission hydraulic oil level.
7. Install and tighten the transmission hydraulic oil filler cap.

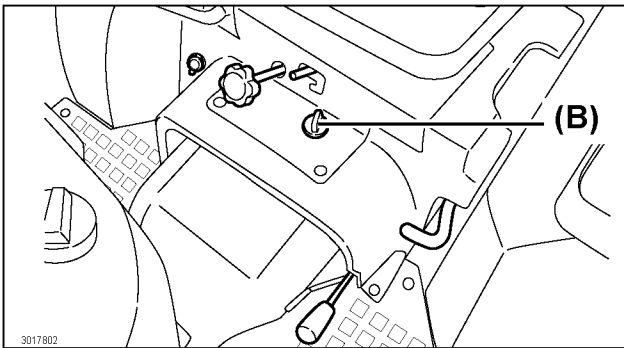
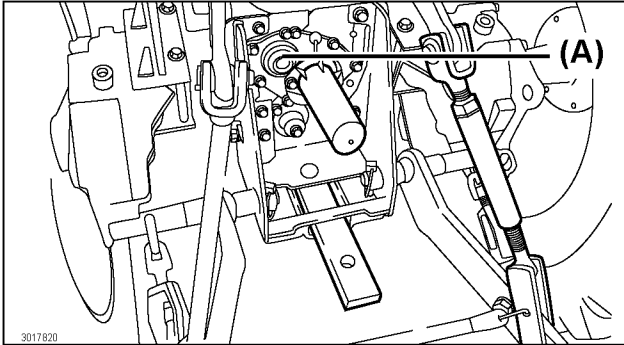

(A) Sight glass
(B) Transmission hydraulic oil filler cap

■ Check the Tire Air Pressure

⚠ WARNING

Avoid injury!

Improperly maintained tires and rim parts can cause explosive separation of the wheels.

- Mounting and dismounting of the tires into and from the rim must be performed by an authorized person using proper equipment.
- Avoid inflating the tires above the recommended tire air pressure.
- Avoid standing in front of or over a tire assembly during inflation.
- Always use a clip-on chuck and extension hose long enough for the tire to be inflated from a safe distance.
- Avoid attempting to weld or apply heat into a rim and tire assembly.
 - welding can structurally weaken or deform the rim
 - heat can cause an increase in tire air pressure and result in an explosion

IMPORTANT

- When checking tire air pressure of liquid filled tires:
 - rotate the tire placing the valve stem on top position
 - the preceding practice prevents the liquid from escaping through the valve stem
- To prevent tire damage:
 - always inflate the tires to less than the maximum tire air pressure shown on the tire sidewall

1. Inspect the tires for fissures or any other damages.
2. Use a tire gauge to check the tire air pressure.
3. Adjust the tires to the standard tire air pressure as per the illustration below.

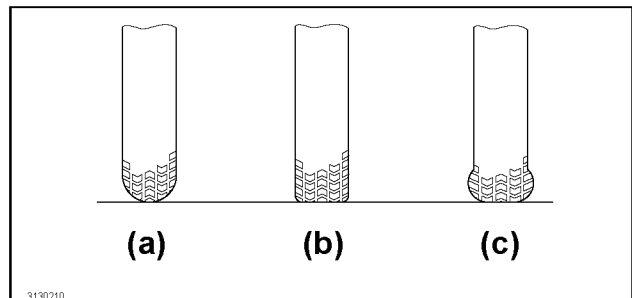

(a) Too high
(b) Standard
(c) Too low

The table below shows the maximum allowed tire air pressure.

Maximum Tire Air Pressure

	Tire Size	Ply Rating	Tire Air Pressure (maximum) psi (MPa)
Front	R3: 24 × 8.50-14 4PR	4	22 (0.152)
	R4: 23 × 8.50-12	6	35 (0.241)
Rear	R3: 36 × 14-15 4PR	4	20 (0.138)
	R4: 14-17.5	6	30 (0.207)

■ Clean the Front Grille and Side Screens

IMPORTANT: Avoid damage!

- To prevent the engine from overheating.
- To ensure adequate air inflow.

1. Check the front grille and the side screens for dirt, grass clippings and debris.
2. Clean the front grille and side screens with a brush or cloth.

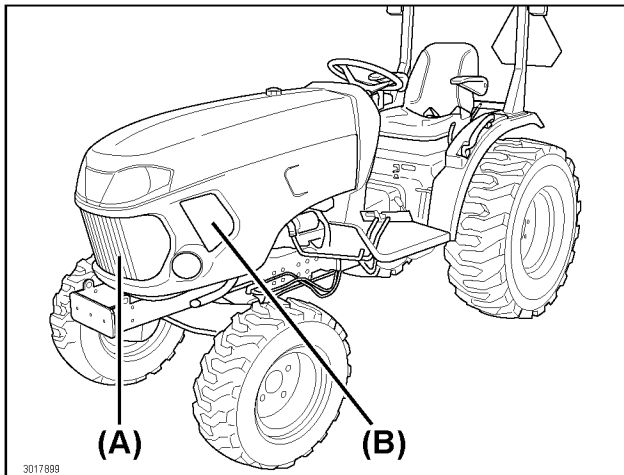

(A) Front grille
(B) Side screens

■ Check the Fuel Line

1. Park the tractor safely and securely.
 - For details, see "7. Safe Practices for Parking the Tractor" on page 1-7.
2. Shut off the engine.
3. Chock all the tires safely and securely.
4. Allow the engine to cool down for several minutes.
5. Raise the hood.
6. Check the fuel rubber hoses for any leaks or damages.

■ Check the Power Steering Line

1. Park the tractor safely and securely.
 - For details, see "7. Safe Practices for Parking the Tractor" on page 1-7.
2. Shut off the engine.
3. Chock all the tires safely and securely.
4. Allow the engine to cool down for several minutes.
5. Check at the lower part and underneath the tractor.
6. Check for leaks and damages on the power steering lines and hoses.

■ Check the Retractable Seatbelt

1. Before operating the tractor:
 - Always ensure that all the retractable seatbelt mounting hardware are in good working condition.
2. Replace any damaged hardware.

■ Check the Roll-Over Protective Structure (ROPS)

1. Before operating the tractor:
 - Always ensure that the Roll-Over Protective Structure (ROPS) mounting hardware are in correct working condition.
2. If any damage hardware is detected:
 - Contact YOUR LOCAL YANMAR TRACTOR DEALER for technical assistance.

■ Check the Headlights, Hazard Lights, etc.

1. Inspect the lights for blown bulb/s and damage lens/es.
2. Replace blown bulb/s and/or damage lens/es.

■ Check and Refill the Fuel Tank

⚠ WARNING

Avoid injury!

Remember that the fuel vapor is explosive and flammable:

- Shut off the engine before refilling the fuel tank.
- Never smoke while handling fuel.
- Keep the fuel away from an open flame or sparks.
- Refuel on outdoors or in a well ventilated area.
- Immediately wipe away any spilled fuel.
- To prevent static electric discharge:
 - use a clean and approved non-metal fuel container
 - use a clean and approved plastic funnel that has no metallic screen mesh or filter

IMPORTANT

- Dirt and water in the fuel can damage the engine.
- Remove dirt and debris from the fuel tank opening.
- Use a clean, fresh and no additive fuel.
- At the end of each day's operation:
 - fill the fuel tank to prevent condensation from occurring in the fuel tank
 - the preceding procedure prevents freezing of the fuel during cold weather
- To fill the fuel tank or container:
 - use a non-metallic funnel that has a plastic mesh strainer
- The fuel tank is vented through the fuel filler cap.
- Replace the fuel filler cap with an approved vented cap as needed.
- Add a fuel conditioner when:
 - storing diesel fuel for a long period of time
 - there is a slow turnover of fuel

1. Park the tractor safely and securely.
 - For details, see "7. Safe Practices for Parking the Tractor" on page 1-7.
2. Turn the starter key switch to ON position.
 - By observing the fuel gauge on the instrument panel.
 - If the reading on the fuel gauge is 1/4 or less.
3. Turn the starter key switch to the OFF position.
4. Chock all the tires safely and securely.
5. Allow the engine to cool down for several minutes.
6. Remove the fuel filler cap.

7. Fill the fuel tank with fresh fuel.

IMPORTANT

- Never overfill the fuel tank.

8. Install the fuel filler cap.

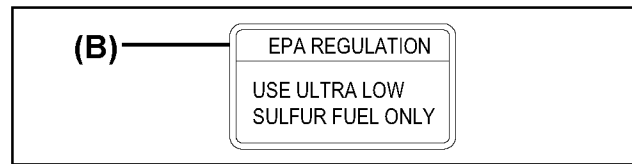
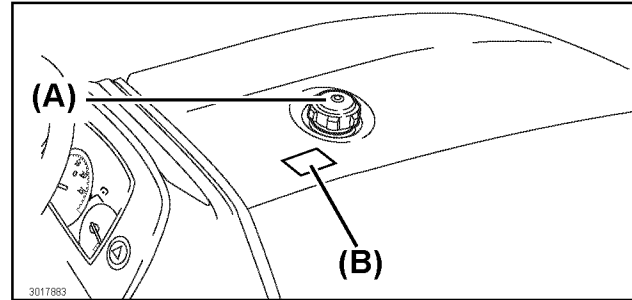

(A) Fuel filler cap

(B) Environmental Protection Agency (EPA) regulation label 14110-07761

EPA REGULATION

USE ULTRA LOW SULFUR FUEL ONLY

Check and Clean the Rubber Dust Unloading Valve

IMPORTANT: Avoid damage!
 Always operate the engine with:

- The air filter element installed.
- The rubber dust unloading valve installed.

1. Park the tractor safely and securely.
 - For details, see "7. Safe Practices for Parking the Tractor" on page 1-7.
2. Shut off the engine.
3. Chock all the tires safely and securely.
4. Allow the engine to cool down for several minutes.
5. Raise the hood.
6. Clean the rubber dust unloading valve.
 - Squeeze the rubber dust unloading valve.
 - Replace the rubber dust unloading valve as necessary.

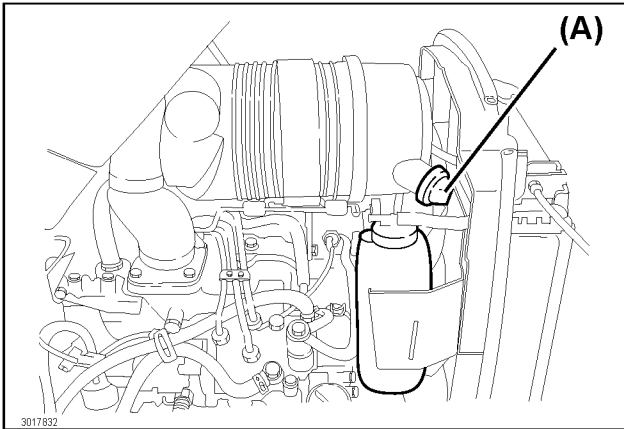

(A) Rubber dust unloading valve

Check the Radiator Hoses and Clamps

1. Park the tractor safely and securely.
 - For details, see "7. Safe Practices for Parking the Tractor" on page 1-7.
2. Shut off the engine.
3. Chock all the tires safely and securely.
4. Allow the engine to cool down for several minutes.
5. Raise the hood.

NOTE

- Visually check the hoses for damages and cracks.
- Squeeze the hoses to check for evidences of deterioration.
- The hoses must not be too hard, brittle, too soft or swollen.
- Replace the damaged hose/s.

6. Check the upper and the lower radiator hoses for any damages and cracks.
7. Replace any damaged hoses.
8. Check for loosen hose clamps.
9. Replace as necessary.
10. Lower the hood.

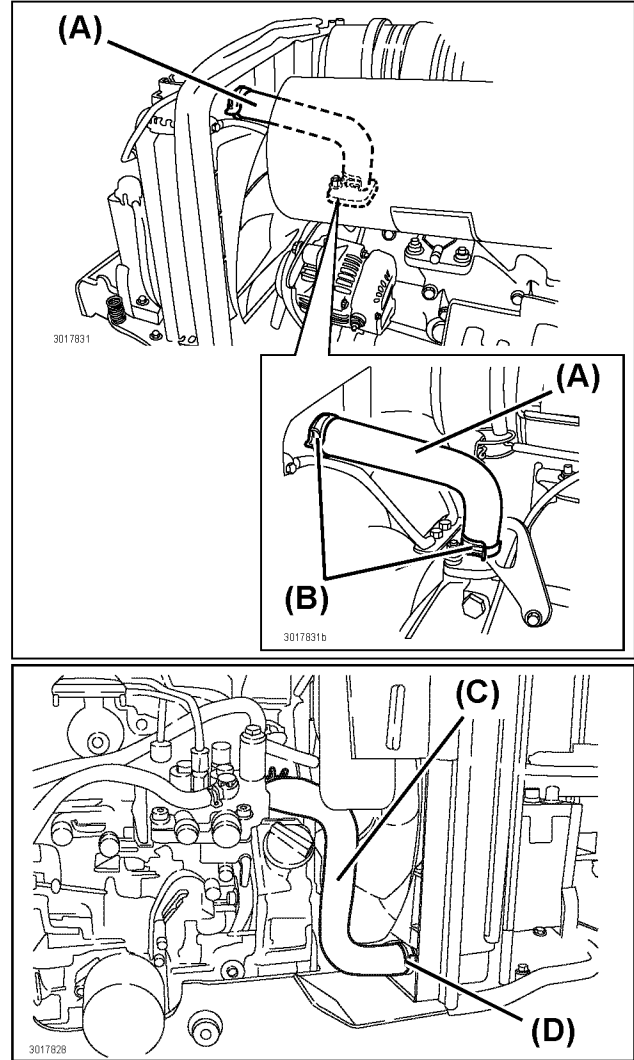

(A) Upper radiator hose
 (B) Hose clamps
 (C) Lower radiator hose
 (D) Hose clamps

■ Clean Radiator Cooling Screen

⚠ WARNING

Compressed air can explosively spray debris and dirt over a wide area:

- Make sure there are no bystander/s near the tractor.
- While using compressed air for cleaning, always wear protective goggles.
- Reduce compressed air pressure to 30 psi (210 kPa).

IMPORTANT

- Keep the cooling screen clean:
 - make sure adequate air inflow is present
 - prevent the engine from overheating

1. Park the tractor safely and securely.
 - For details, see "7. Safe Practices for Parking the Tractor" on page 1-7.
2. Shut off the engine.
3. Chock all the tires safely and securely.
4. Allow the engine to cool down for several minutes.
5. Raise the hood.
6. Remove the air intake pipe from the top of the radiator.
7. Hold the tab to pull out the radiator cooling screen from the radiator.
8. Remove straw and dust attached from the radiator cooling screen.

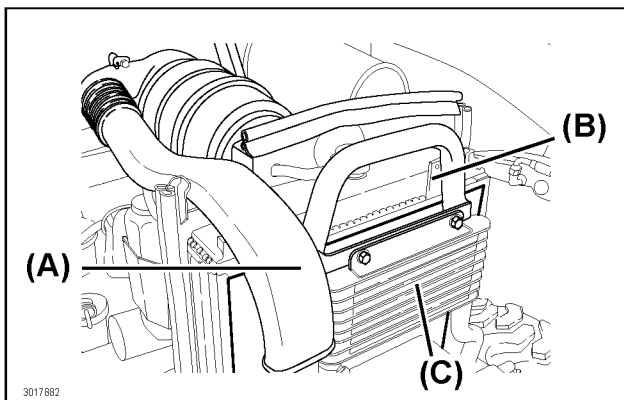

(A) Air intake pipe
 (B) Tab
 (C) Radiator cooling screen

■ Clean Radiator Cooling Fins

⚠ WARNING

Avoid injury!

Compressed air can explosively spray debris and dirt over a wide area:

- Make sure there are no bystander/s near the tractor.
- While using compressed air for cleaning, always wear protective goggles.
- Reduce compressed air pressure to 30 psi (210 kPa).

IMPORTANT: Avoid damage!

- To prevent overheating:
 - keep the radiator cooling fins clean
- When cleaning the radiator cooling fins:
 - avoid using pressure washers, which can damage the radiator cooling fins
- Prevent the radiator cooling fins from bending:
 - avoid spraying compressed air directly into the radiator cooling fins

1. Park the tractor safely and securely.
 - For details, see "7. Safe Practices for Parking the Tractor" on page 1-7.
2. Shut off the engine.
3. Chock all the tires safely and securely.
4. Allow the engine to cool down for several minutes.
5. Raise the hood.

6. Clean the radiator cooling fins from all dirt and debris:
 - In the direction indicated by the arrow in the illustration.
 - Use low pressure, compressed air or water.
 - During the preceding procedure, maintain maximum distance to the engine.
7. Install the radiator cooling screen.
8. Lower the hood.

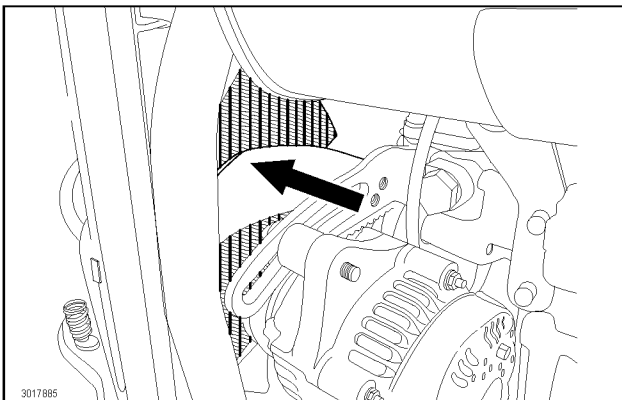
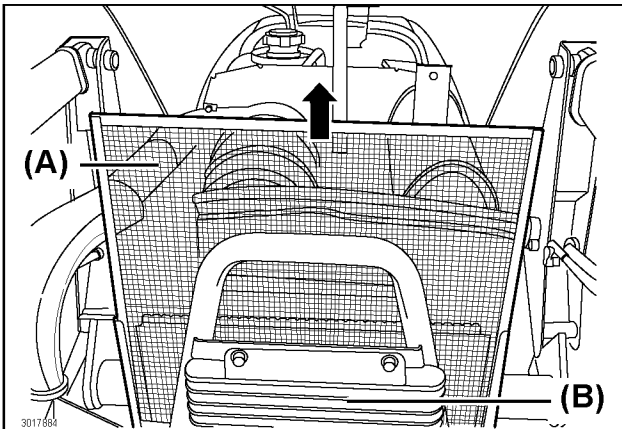

(A) Radiator cooling screen
(B) Radiator cooling fins

■ Check the Wheel Bolt Tightening Torque

Service Intervals

- Regular intervals: Before daily operation.
- After adjusting the tire tread width and after replacing the tires:
 - after 1 hour of operation
 - every 4 hours after that until appropriate tightening torque values are reached and maintained

For more information on maintenance work on the wheel bolt tightening torque, for details, see "Check the Wheel Bolt Tightening Torque" on page 12-2.

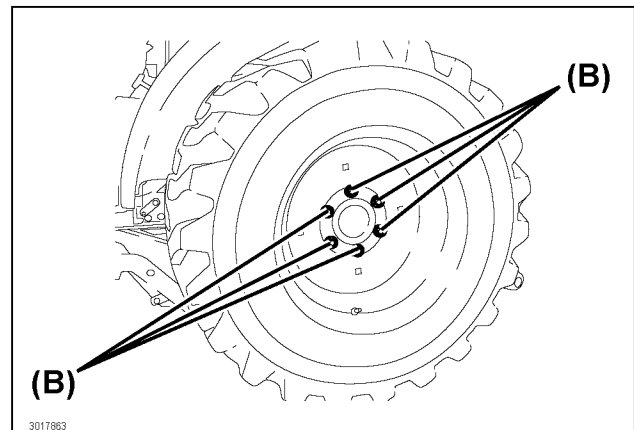
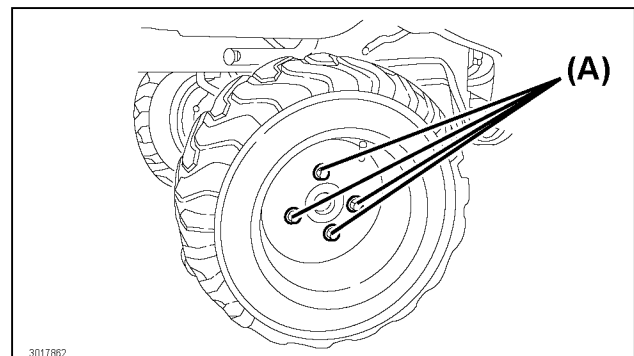

(A) Front wheel bolts
(B) Rear wheel bolts

■ Inspection Procedure for the Safety Interlock System

WARNING

NEVER inhale the engine exhaust gas.



- Read the **DANGER, WARNING AND CAUTION** statements on the safety alert decals on the tractor.
- Before starting the engine:
 - remain seated on the operator seat
 - the parking brake lock is engaged
 - release the forward and reverse drive pedals completely
 - range gear lever is in the N (neutral) position
 - push down Power Take Off (PTO) switch to OFF position
 - never attempt to start the engine while the operator is still on the ground
- Engine exhaust gas contains carbon monoxide.
 - if inhaled, the engine exhaust gas can cause severe poisoning or even death
- Always perform the safety checks in a well ventilated area.
- When working in an enclosed area, always expel the engine exhaust gas to an outdoor area.
 - connect one end of an extension pipe to the engine exhaust pipe
 - set the other end outside of the work area
- Allow fresh outside air to flow into an enclosed work area to remove the engine exhaust gas from the area.

Before operating the tractor, ALWAYS:

- Get familiarized with the operation of the tractor.
- Perform the safety checks on the tractor's safety interlock system.

If a problem is detected on the safety interlock system:

- Do not attempt to operate the tractor.
- Contact YOUR LOCAL YANMAR TRACTOR DEALER for technical assistance.

1. Range Gear Lever Neutral Switch

1. Sit on the operator seat.
2. Engage the parking brake securely, for details, see "6. Lock and Set the Parking Brake" on page 7-3.
3. Push down Power Take Off (PTO) switch to OFF position.
4. Move the range gear lever to the H (fast) or L (slow) position.
5. Turn the starter key switch to the START position.

NOTE

- The engine must not crank when the range gear lever is in the H (fast) or L (slow) position.

6. Confirm that the starter motor does not operate.
7. Move the range gear lever to the N (neutral) position.
8. Start the engine to activate the starter motor.

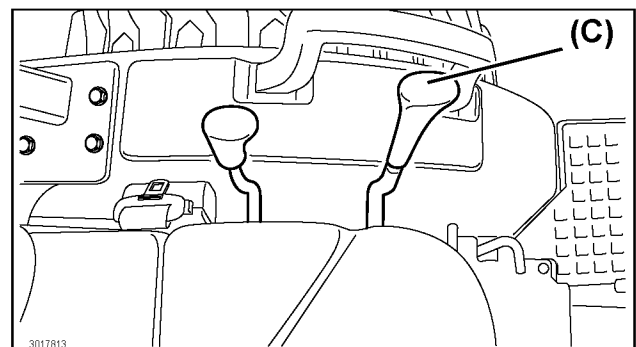
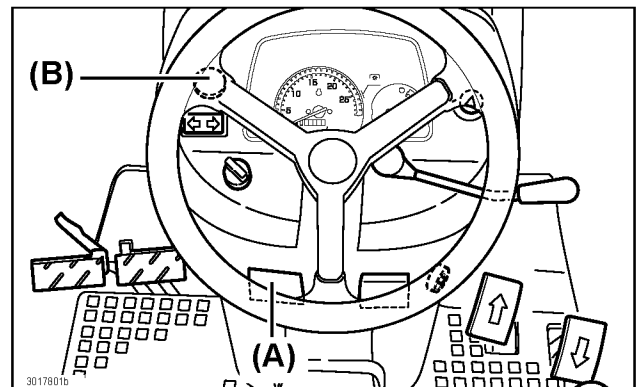

(A) Parking brake lock lever
 (B) Power Take Off (PTO) switch
 (C) Range gear lever

2. Power Take Off (PTO) Safety Switch

1. Sit on the operator seat.
2. Engage the parking brake securely, for details, see "6. Lock and Set the Parking Brake" on page 7-3.
3. Move the range gear lever to N (neutral) position.
4. Pull up the Power Take Off (PTO) switch to ON position.
5. Turn the starter key switch to the START position.

NOTE

- The engine must not crank when the Power Take Off (PTO) switch is in the ON position.

6. Confirm that the starter motor does not operate.
7. Push down Power Take Off (PTO) switch to OFF position.
8. Start the engine to activate the starter motor.

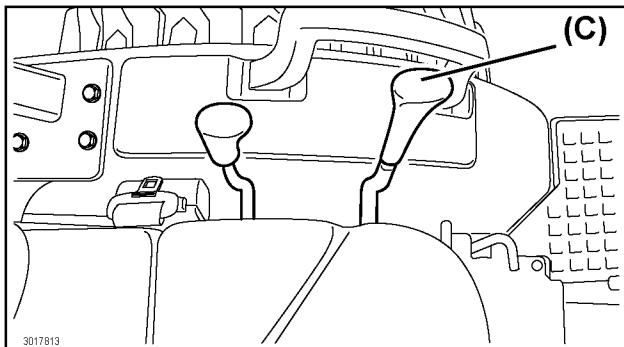
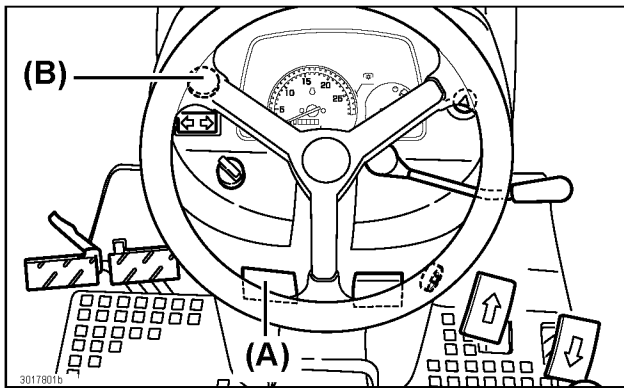

(A) Parking brake lock lever
(B) Power Take Off (PTO) switch
(C) Range gear lever

3. Seat Switch

1. Sit on the operator seat.
2. Move counterclockwise the brake pedal connector lock to lock together the left and right brake pedals.
3. Engage the parking brake securely, for details, see "6. Lock and Set the Parking Brake" on page 7-3.

4. Push down Power Take Off (PTO) switch to OFF position.
5. Move the Range gear lever to the N (neutral) position.
6. Turn the starter key switch to START position.
7. Slightly rise up from the operator seat to remove weight from the operator seat.

IMPORTANT

- Do not dismount from the tractor.

8. Make sure that the engine has shut off.

NOTE

- The engine must stop when the operator is not sitting on the operator seat.

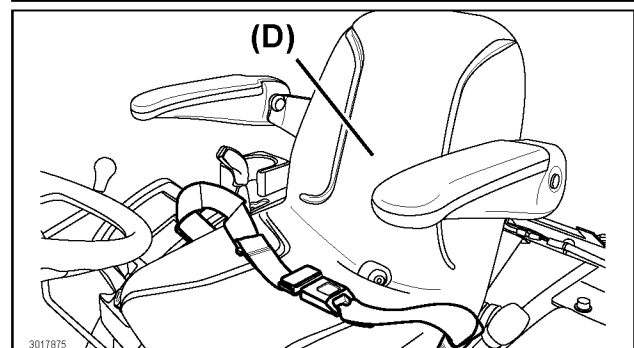
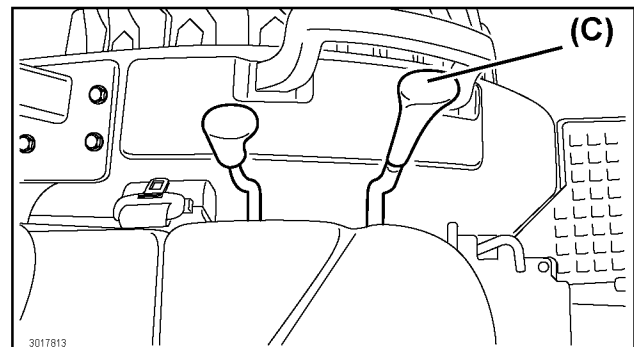
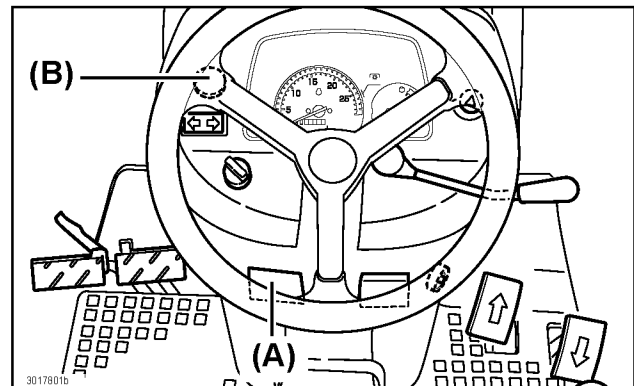

(A) Parking brake lock lever
(B) Power Take Off (PTO) switch
(C) Range gear lever
(D) Operator seat

4. Mid-Power Take Off (PTO) Safety Switch and Seat Switch Interface

1. Sit on the operator seat.
2. Engage the parking brake securely, for details, see "6. Lock and Set the Parking Brake" on page 7-3.
3. Push down the Power Take Off (PTO) switch to OFF position.
4. Move the range gear lever to the N (neutral) position.
5. Turn the starter key switch to the START position.
6. Move the Mid-/Rear Power Take Off (PTO) select lever to either of the following positions:
 - Mid-Power Take Off (PTO) position.
 - Mid-/Rear Power Take Off (PTO) position.
7. Pull up the Power Take Off (PTO) switch to turn ON the Power Take Off (PTO) system.
8. Rise up from the operator seat to remove weight from the operator seat.

IMPORTANT

- Do not dismount the tractor.

9. Confirm that the engine has shut off.
10. Turn the starter key switch to OFF position.

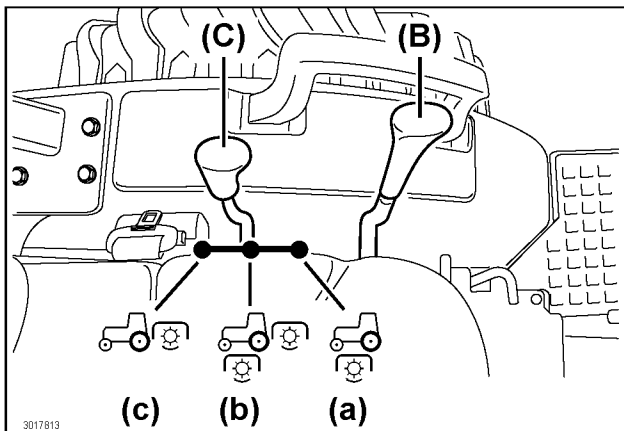
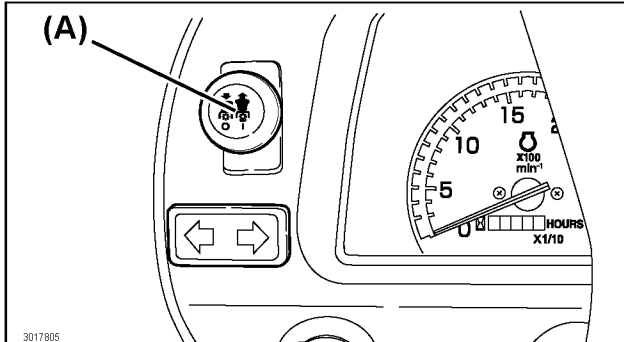

(A) Power Take Off (PTO) switch
 (B) Range gear lever
 (C) Mid-/Rear Power Take Off (PTO) select lever
 (a) Mid-Power Take Off (PTO) position
 (b) Mid-/Rear Power Take Off (PTO) position
 (c) Rear Power Take Off (PTO) position

5. Rear Power Take Off (PTO)/ Parking Brake Interface

1. Sit on the operator seat.
2. Engage the parking brake securely, for details, see "6. Lock and Set the Parking Brake" on page 7-3.
3. Push down the Power Take Off (PTO) switch to OFF position.
4. Move the range gear lever to the N (neutral) position.
5. Turn the starter key switch to the START position.
6. Move the Mid-/Rear Power Take Off (PTO) select lever backward to engage the Rear Power Take Off (PTO) operation.
7. Pull up the Power Take Off (PTO) switch to turn ON the Power Take Off (PTO) system.
8. Slightly rise up from the operator seat to remove weight from the operator seat.

IMPORTANT

- Do not dismount the tractor.

9. Confirm that the Rear Power Take Off (PTO) continues to operate.
10. Sit on the operator seat.
11. Disengage the parking brake.
12. Slightly rise up from the operator seat to remove weight from the operator seat.

IMPORTANT

- Do not dismount the tractor.

13. Confirm that the engine has shut off.
14. Push down the Power Take Off (PTO) switch to OFF position.
15. Turn the starter key switch to the OFF position.

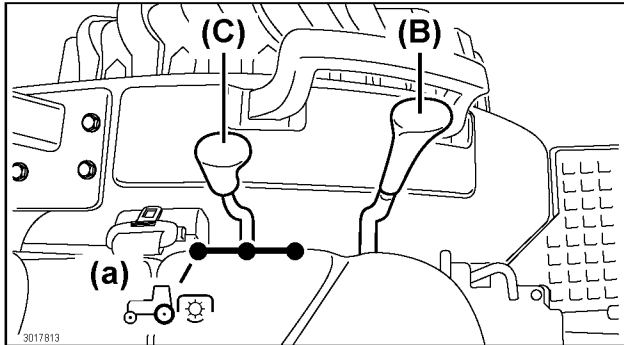
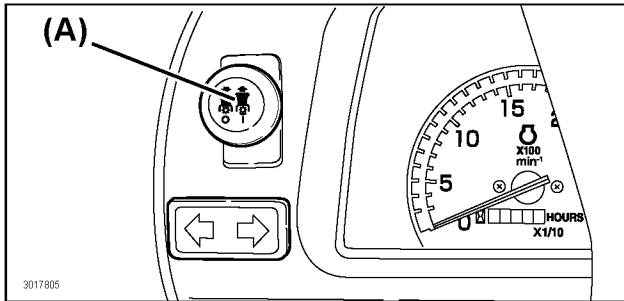

(A) Power Take Off (PTO) switch
 (B) Range gear lever
 (C) Mid-/Rear Power Take Off (PTO) select lever
 (a) Rear Power Take Off (PTO) position

■ Check the Cooling System

⚠ WARNING

Avoid injury!

- Before checking always allow the radiator to cool down:
 - the radiator is hot and can cause burns
 - the build up pressure in the cooling system can cause the coolant to spray out explosively during removal of the radiator cap
- Always shut off the engine.
- Allow the engine to cool down.
- Remove the radiator cap only when:
 - the radiator and the engine are sufficiently cooled down that can be touched with bare hands
- When removing the radiator cap, always:
 - loosen the radiator cap to the first stop
 - the preceding action releases excessive pressure on the radiator
 - fully remove the radiator cap once the pressure has been released completely
- Add coolant or water to reserve tank, not to the radiator.

1. Park the tractor safely and securely.
 - For details, see "7. Safe Practices for Parking the Tractor" on page 1-7.
2. Shut off the engine.
3. Chock all the tires safely and securely.
4. Allow the engine to cool down for several minutes.
5. Raise the hood.

6. Check the coolant level of the reserve tank:
 - If the engine is warm, the coolant level must be between the full line and the low line.
 - If the engine is cold, the coolant level must be at the low line on the reserve tank.
7. When necessary, remove the reserve tank cap and add coolant.
8. Add a pre-diluted coolant with an antifreeze water ratio that suits the local climate.
 - Contact YOUR LOCAL YANMAR TRACTOR DEALER for more details.
 - Use High Quality Permanent Type Antifreeze (Ethylene Glycol with corrosion and rust inhibitor chemicals).
9. Install the reserve tank cap.
10. Lower the hood.
11. Confirm that the hood latch locked securely.

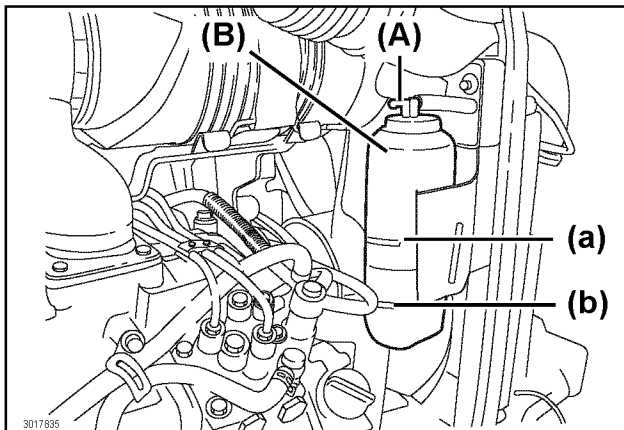

(A) Reserve tank cap
 (B) Reserve tank
 (a) FULL line
 (b) LOW line

3. Check and Replace as Necessary

■ Inspect the Alternator/Fan Belt

- Perform a visual inspection on the alternator/fan belt.
- Check for loose alternator/fan belt tension or damaged alternator/fan belt.

For more information on maintenance work on the alternator/fan belt, for detail, see "Service the Alternator/Fan Belt" on page 14-20.

■ Check and Replace the Battery

For details, see "1. Battery" on page 15-1.

■ Check the Fuses

For details, see "2. Fuses" on page 15-4.

■ Check the Light Bulbs

For details, see "3. Bulb" on page 15-5.

■ Check and Drain the Fuel/Water Separator

For details, see "Check the Fuel/Water Separator" on page 14-21.

4. First 50 Hours

■ Change the Engine Oil

For maintenance work, see "Change the Engine Oil and Engine Oil Filter" on page 14-24.

■ Replace the Engine Oil Filter

For maintenance work, see "Change the Engine Oil and Engine Oil Filter" on page 14-24.

■ Replace the Transmission Hydraulic Oil Filters

For maintenance work, see "Change the Transmission Hydraulic Oil and Replace the Transmission Hydraulic Oil Filters and Clean Transmission Hydraulic Oil Strainer" on page 14-26.

■ Change the Transmission Hydraulic Oil

For maintenance work, see "Change the Transmission Hydraulic Oil and Replace the Transmission Hydraulic Oil Filters and Clean Transmission Hydraulic Oil Strainer" on page 14-26.

■ Clean the Transmission Hydraulic Oil Strainer

For maintenance work, see "Change the Transmission Hydraulic Oil and Replace the Transmission Hydraulic Oil Filters and Clean Transmission Hydraulic Oil Strainer" on page 14-26.

■ Change the Alternator/Fan Belt

For maintenance work, see "Service the Alternator/Fan Belt" on page 14-20.

5. Every 50 Hours

■ Check the Front Axle Oil Level

IMPORTANT

- Before checking the front axle gear oil level, allow the front axle gear oil to settle for 1 hour until the current front axle gear oil level can be accurately read on the dipstick.
- Recheck the front axle gear oil level after operating the tractor for several hours.

1. Park the tractor safely and securely.
 - For details, see "7. Safe Practices for Parking the Tractor" on page 1-7.
2. Shut off the engine.
3. Chock all the tires safely and securely.
4. Allow the engine to cool down for several minutes.
5. Make the front axle gear oil settle for at least 1 hour.

IMPORTANT

- Dirt and debris in the front axle gear oil can damage the front axle components.
- Clean the area around the dipstick before removing the dipstick.

6. Loosen and remove the dipstick located on the right side of the front axle.
7. Use a clean rag to wipe the front axle gear oil from the dipstick.
8. Insert the dipstick into the hole without tightening.

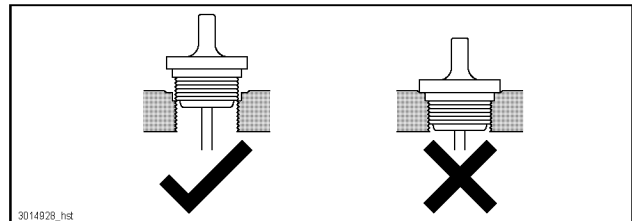

9. Remove the dipstick again.
10. Check the front axle gear oil level on the dipstick.

11. The front axle gear oil level must be between the upper and lower marks on the dipstick.

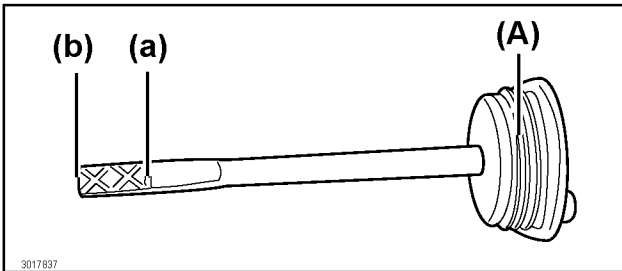
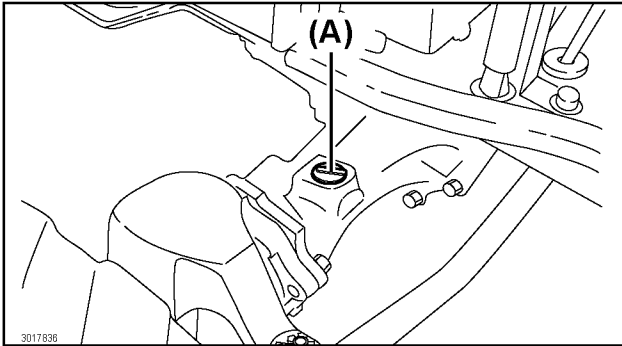

(A) Dipstick
 (a) Upper mark
 (b) Lower mark

IMPORTANT

When the front axle gear oil level is low:
 ● Add SAE 80W-90 gear oil through the fill opening until the front axle gear oil level is appropriate.

- 12. Install and tighten the dipstick.
- 13. Operate the tractor for several hours.
- 14. Check the front axle gear oil level again.

■ Grease Up

IMPORTANT

- Use the recommended greases by Yanmar.
 - the preceding procedure prevents premature wear or failure of the parts and components
- The recommended greases by Yanmar perform efficiently in an average ambient temperature range from -20 to +275 °F (-29 to +135 °C).
- When intending to operate the tractor outside the preceding temperature range:
 - contact YOUR LOCAL YANMAR TRACTOR DEALER for the applicable special purpose greases

1. Lubricate the Grease Fittings on the Tie-Rod

Extremely Wet or Muddy Conditions

Lubricate the grease fittings once every 10 operating hours or once a day.

All Other Conditions

Lubricate the grease fittings once every 50 operating hours.

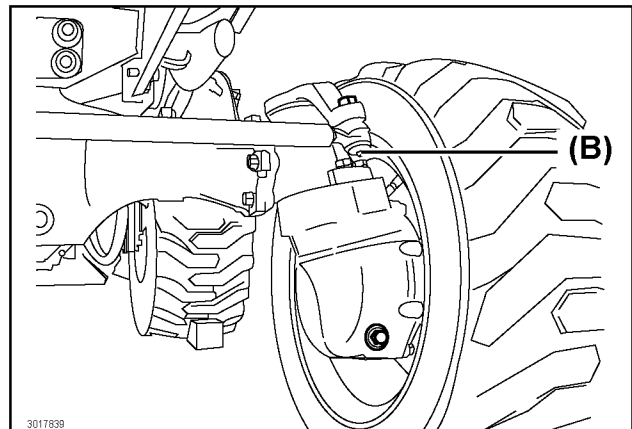
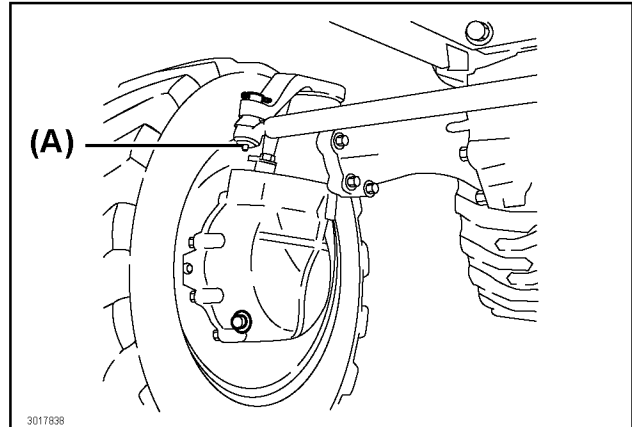

(A) Right tie-rod end
 (B) Left tie-rod end

2. Check and Lubricate the Front Axle Pivot

Extremely Wet or Muddy Conditions

Lubricate the grease fittings once every 10 operating hours or once a day.

All Other Conditions

Lubricate the grease fittings once every 50 operating hours.

1. Check for looseness the 4 bolts holding the center pin.
2. Tighten any loose bolts.

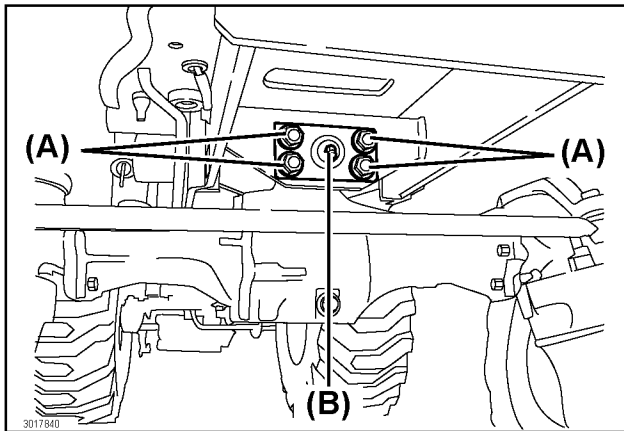

(A) Bolts
(B) Front axle pivot pin grease fitting

NOTE

- The front axle pivot pin grease fitting is located below the front platform of the tractor.

3. Lubricate the Grease Fittings on the Brake and the Parking Brake Linkage

Extremely Wet or Muddy Conditions

Lubricate the grease fittings once every 10 operating hours or once a day.

All Other Conditions

Lubricate the grease fittings once every 50 operating hours.

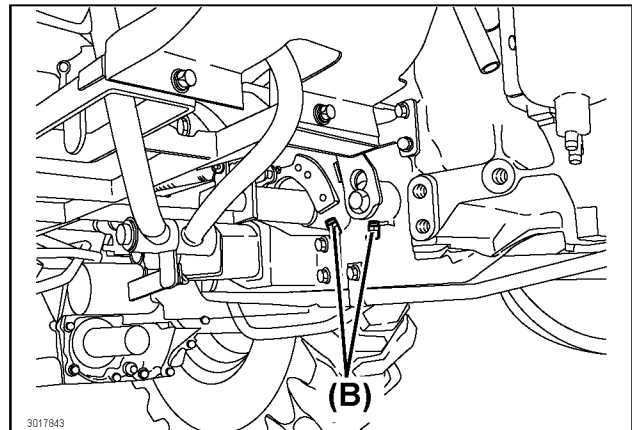
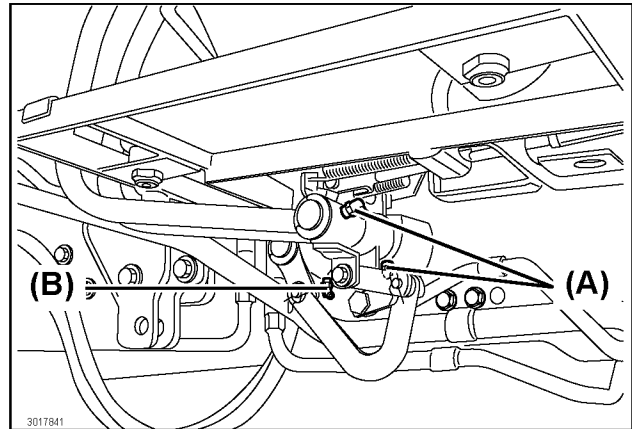

(A) Brake link grease fittings
(B) Parking brake link grease fittings

NOTE

- The brake and parking brake linkages grease fitting are located on the 2 cross shafts below the center of the tractor.

4. Lubricate the Operator Seat Slide Rails

Lubricate the operator seat slide rails with SUPER LUBE[®] lubricants once every 50 operating hours. SUPER LUBE[®] is a registered trademark of Synco Chemical Corp[®].

1. Move the operator seat forward.
2. Lubricate the rear part of the operator seat slide rails with SUPER LUBE[®] lubricants.
3. Move the operator seat backward.
4. Lubricate the front part of the operator seat slide rails.

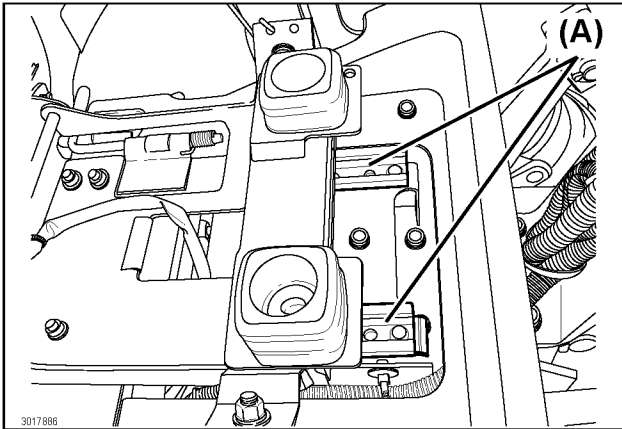

(A) Operator seat slide rails

5. Lubricate the 3-Point Hitch

Lubricate the ball joints with SUPER LUBE[®] lubricants once every 50 operating hours. SUPER LUBE[®] is a registered trademark of Synco Chemical Corp[®].

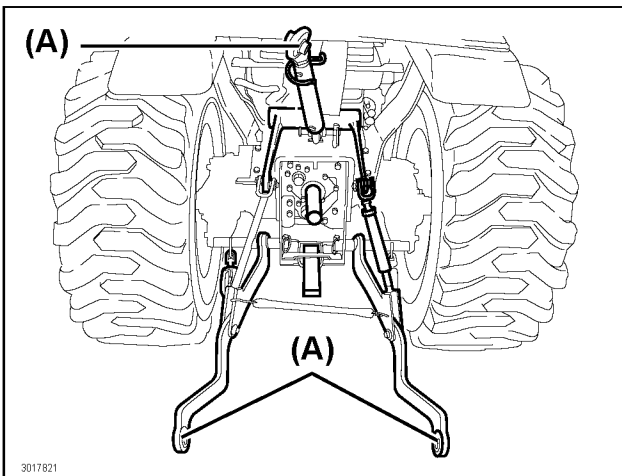

(A) Ball joints

6. Lubricate the Hood Lock

Lubricate the hood lock with SUPER LUBE[®] lubricants once every 50 operating hours. SUPER LUBE[®] is a registered trademark of Synco Chemical Corp[®].

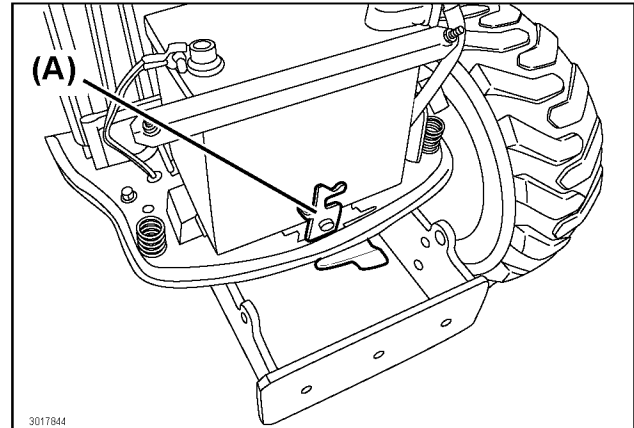

(A) Hood lock

7. Lubricate the Implement Control Valve Linkages

Lubricate the implement control valve linkages and the implement lock lever with SUPER LUBE[®] lubricants once every 50 operating hours. SUPER LUBE[®] is a registered trademark of Synco Chemical Corp[®].

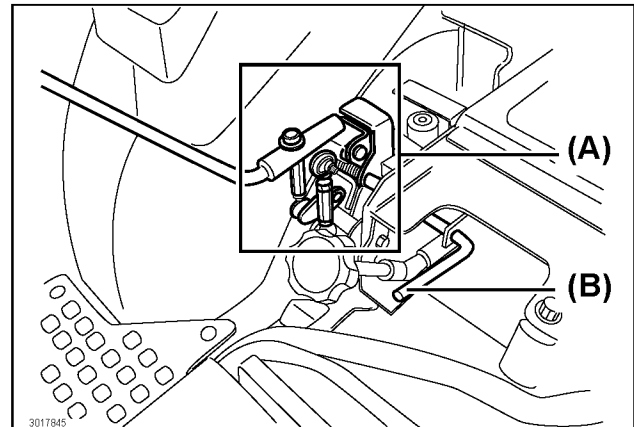

(A) Implement control valve linkages
(B) Implement control lever lock

■ Service the Alternator/Fan Belt

⚠ WARNING

Avoid injury!

- Fingers or loose clothing can get entangled with rotating parts.
- Before performing maintenance, shut off the engine.
- Allow all the moving parts to completely stop.

1. Check the Alternator/Fan Belt

1. Park the tractor safely and securely.
 - For details, see "7. Safe Practices for Parking the Tractor" on page 1-7.
2. Shut off the engine.
3. Chock all the tires safely and securely.
4. Allow the engine to cool down for several minutes.
5. Raise the hood.
6. Using the thumb, gently apply pressure to the midpoint of the alternator/fan belt between the pulleys.
7. Check whether the alternator/fan belt deflects inward by approximately 0.4 to 0.6 in. (10 to 15 mm).
8. If the deflection is not as specified, adjust the tension of the alternator/fan belt.

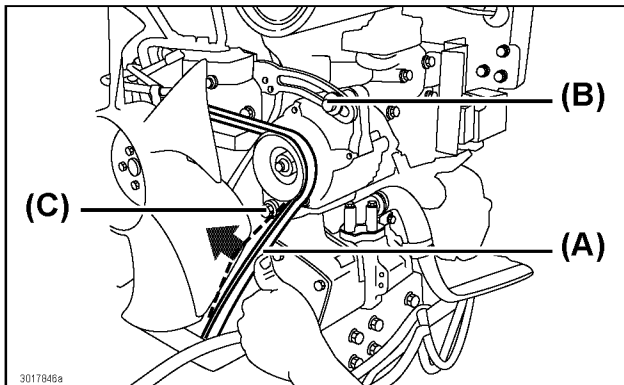

(A) 0.4 to 0.6 in. (10 to 15 mm)
 (B) Adjusting bolt
 (C) Mounting bolt

2. Adjust the Alternator/Fan Belt Tension

1. Loosen the adjusting bolt.
2. Loosen the mounting bolt.
3. Exert an outward pressure on the alternator housing to attain the correct tension.
4. Tighten the adjusting bolt and the mounting bolt, in that order.
5. Check the alternator/fan belt tension.

6. Lower the hood.
7. Confirm that the hood latch locked securely.

3. Replace the Alternator/Fan Belt

NOTE

- Replace an excessively worn out, damaged or elongated alternator/fan belt with a new alternator/fan belt.

1. Park the tractor safely and securely.
 - For details, see "7. Safe Practices for Parking the Tractor" on page 1-7.
2. Shut off the engine.
3. Chock all the tires safely and securely.
4. Allow the engine to cool down for several minutes.
5. Raise the hood.
6. Loosen the adjusting bolt.
7. Loosen the mounting bolt.
8. Apply an inward pressure to the alternator housing.
9. Remove the alternator/fan belt from the alternator sheave, fan sheave and crankshaft sheave.
10. Route the defective alternator/fan belt over the fan and remove the alternator/fan belt.
11. Install a new alternator/fan belt over the fan and onto the sheaves.
12. Exert an outward pressure to the alternator housing to attain the correct tension.
13. Tighten the adjusting bolt and the mounting bolt, in that order.
14. Check the alternator/fan belt tension.
15. Lower the hood.
16. Confirm that the hood latch locked securely.

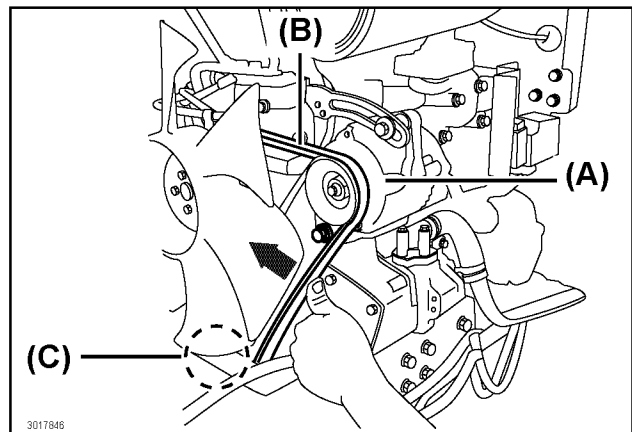

(A) Alternator sheave
 (B) Fan sheave
 (C) Crankshaft sheave

■ Check the Fuel/Water Separator

⚠ WARNING

Avoid injury!

Remember that diesel fuel vapor is explosive and flammable:

- Never smoke while handling diesel fuel.
- Keep the diesel fuel away from open flame or sparks.
- Before performing maintenance, shut off the engine and allow the engine to cool down.
- Work in a well ventilated area.
- Immediately wipe away any spilled diesel fuel.

NOTE

- Change the fuel filter if the fuel in the tank runs out while the engine is running.

1. Park the tractor safely and securely.
 - For details, see "7. Safe Practices for Parking the Tractor" on page 1-7.
2. Shut off the engine.
3. Chock all the tires safely and securely.
4. Allow the engine to cool down for several minutes.
5. Turn the fuel shut-off valve to the OFF (closed) position.
6. Turn the drain cock at the bottom of the fuel/water separator to drain away the water condensation.
7. Close the drain cock.
8. Turn the fuel shut-off valve to the ON (open) position.

NOTE

- The fuel system is self bleeding.

9. Turn the starter key switch to START position. Allow any trapped air to be bled from the fuel system. If necessary, contact YOUR LOCAL YANMAR TRACTOR DEALER for technical assistance.

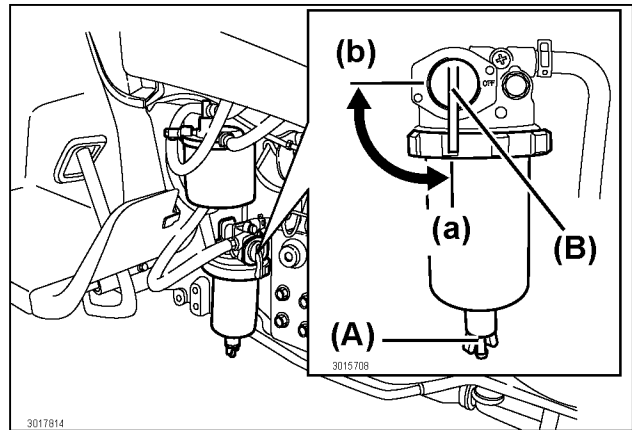

(A) Drain cock
 (B) Fuel shut-off valve
 (a) ON (open) position
 (b) OFF (closed) position

■ Check the Battery Condition

For maintenance work, see "Chapter 15. SERVICE THE ELECTRICAL SYSTEM".

6. Every 100 Hours

■ Service the Air Cleaner Element

⚠ WARNING

Avoid injury!

- Touching hot surfaces can burn skin.
- If the engine has been running for some time, the engine components are hot including all internal fluids.
- Before performing maintenance or working near the engine and engine parts:
 - allow the engine to cool down
 - always wear protective goggles and protective clothing

IMPORTANT

A damaged air cleaner element can fail to prevent dirt, dust and other contaminants from entering the engine.

- Never wash the inner filter.
- Never attempt to clean the inner filter by tapping the inner filter against another object.
- Never use a compressed air to clean the inner filter.
- Always replace a contaminated, damaged and cracked inner filter seal.

1. Service the Outer Filter

1. Park the tractor safely and securely.
 - For details, see "7. Safe Practices for Parking the Tractor" on page 1-7.
2. Shut off the engine.
3. Chock all the tires safely and securely.
4. Allow the engine to cool down for several minutes.
5. Raise the hood.
6. Release the two latch hooks.
 - The latch hooks secures the air cleaner canister cover to the air cleaner canister.
7. Unhook the latch hooks from the air cleaner canister.
8. Remove the air cleaner canister cover.

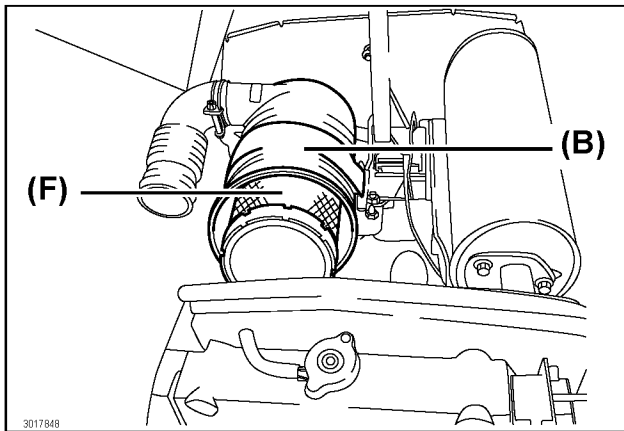
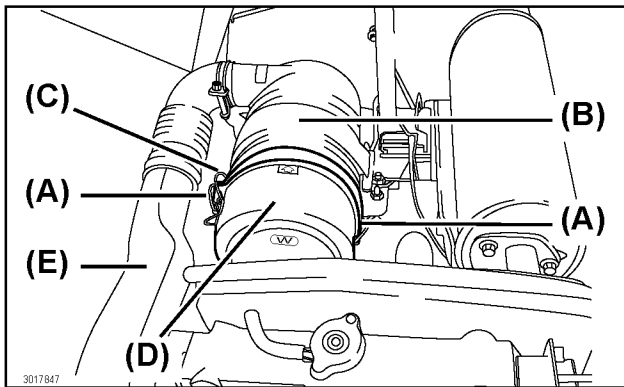

- (A) Latch hook
- (B) Air cleaner canister
- (C) Latches
- (D) Air cleaner canister cover
- (E) Air intake
- (F) Outer filter

9. Remove the outer filter.
10. Clean the outer filter using the procedure below.
 - When dust is found on the element:
 - apply compressed air from inside the element to blow away the dust
 - keep the compressed air pressure below 30 psi (205 kPa)
 - If carbon or oil deposits are found on the outer filter:
 - replace the outer filter

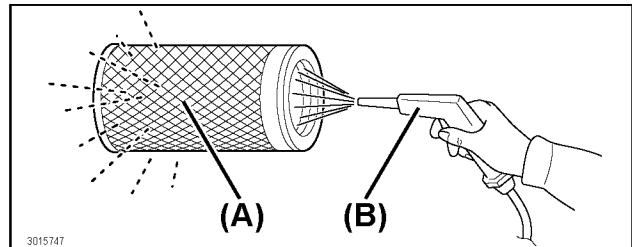

- (A) Outer filter
- (B) Compressed air

11. Install the outer filter.
12. Replace the old outer filter with a new outer filter, as necessary.
13. Install the air cleaner canister cover.
14. Make sure the rubber dust unloading valve points outward.
15. Align the arrow on the air cleaner canister with the arrow shown on the air cleaner canister cover.
16. Hook the two latch hooks onto the air cleaner canister.

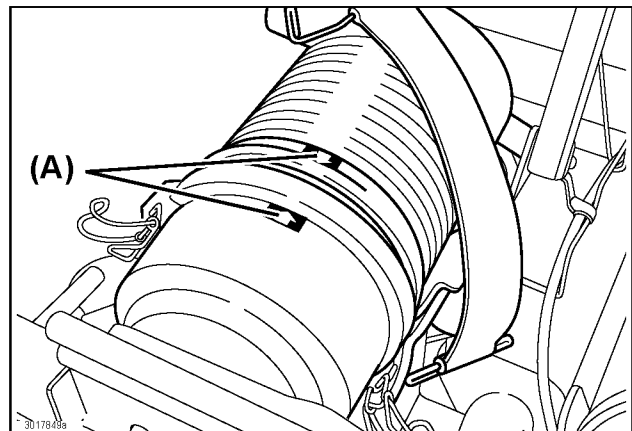

- (A) Arrows (aligning)

17. Push the top of the latch hooks inward toward the air cleaner canister cover:
 - To lock the latch hooks.
 - To secure the air cleaner canister cover.

NOTE
 ● Replace the outer filter at least once a year.

2. Service the Inner Filter

1. Remove the air cleaner canister cover.
2. Remove the outer filter.
3. Remove the inner filter.
4. Clean the inside of the air cleaner canister.
5. Install a new inner filter as necessary.

IMPORTANT

- Do not use the old inner filter.

6. Install the outer filter.
7. Install the air cleaner canister cover.
8. Lower the hood.

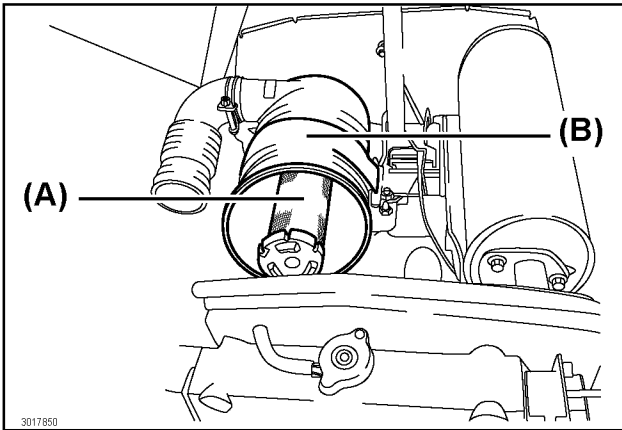

(A) Inner filter
(B) Air cleaner canister

NOTE

- Replace the inner filter at least once a year.

IMPORTANT

- The main purpose of the inner filter is to:
 - protect the engine against dust when a fouled up outer filter is removed
- Do not remove the inner filter during maintenance work on the outer filter.

■ Clean the Fuel/Water Separator and Replace the Fuel Filter

⚠ WARNING

Avoid injury!

Remember that diesel fuel vapor is explosive and flammable:

- Never smoke while handling diesel fuel.
- Keep the diesel fuel away from open flame or sparks.
- Before performing maintenance, shut off the engine and allow the engine to cool down.
- Work in a well ventilated area.
- Immediately wipe away any spilled diesel fuel.

NOTE

- Change the fuel filter if the fuel in the tank runs out while the engine is running.

1. Park the tractor safely and securely.
 - For details, see "7. Safe Practices for Parking the Tractor" on page 1-7.
2. Shut off the engine.
3. Chock all the tires safely and securely.
4. Allow the engine to cool down for several minutes.
5. Turn the fuel shut-off valve to the OFF (closed) position.
6. Place a drain pan underneath the fuel/water separator to catch any spilled fuel. Dispose of the waste fuel properly following effective local law.
7. Turn the locking collar counterclockwise to unlock the sediment bowl.
8. Pull down the sediment bowl to remove from separator body.
9. Remove the fuel filter from the separator body. Dispose of the fuel filter properly following effective local law.
10. Clean the sediment bowl.
11. Install the new fuel filter into the separator body.
12. Install the sediment bowl and turn the locking collar clockwise to secure the bowl.
13. Turn the fuel shut-off valve to the ON (open) position.

NOTE

- The fuel system is self bleeding.

14. Turn the starter key switch to START position.
15. Allow any trapped air to bleed from the fuel system.

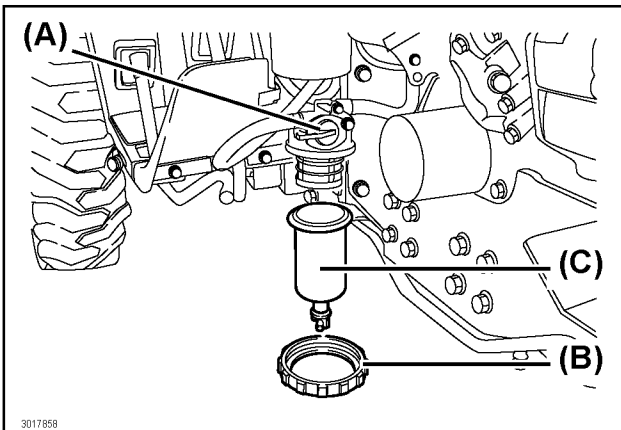
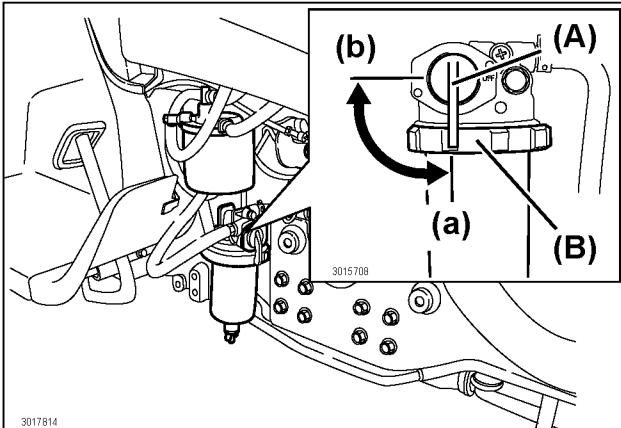

- (A) Fuel shut-off valve
- (B) Locking collar
- (C) Sediment bowl
- (a) ON (open) position
- (b) OFF (closed) position

7. Every 200 Hours

■ Engine Oil

Use oil with a viscosity that is appropriate for use within the air temperature range:

- Wherein the tractor is scheduled to operate until the next oil change.

Engine Crankcase

Capacity	Lubricant
Approximately 3.9 qt. (3.6 L)	API Service Classifications CF or higher SAE 10W-30 or SAE 10W-40

■ Change the Engine Oil and Engine Oil Filter

IMPORTANT

Change the engine oil more frequently if the tractor is used in extremely demanding conditions such as the following:

- Extremely dusty conditions.
- Frequent slow-speed operation.
- Frequent short trips.

1. Run the engine to warm up the engine oil.
2. Park the tractor safely and securely.
 - For details, see "7. Safe Practices for Parking the Tractor" on page 1-7.
3. Shut off the engine.
4. Chock all the tires safely and securely.
5. Allow the engine to cool down for several minutes.
6. Raise the hood.
7. Place an oil pan underneath the engine oil drain plug.

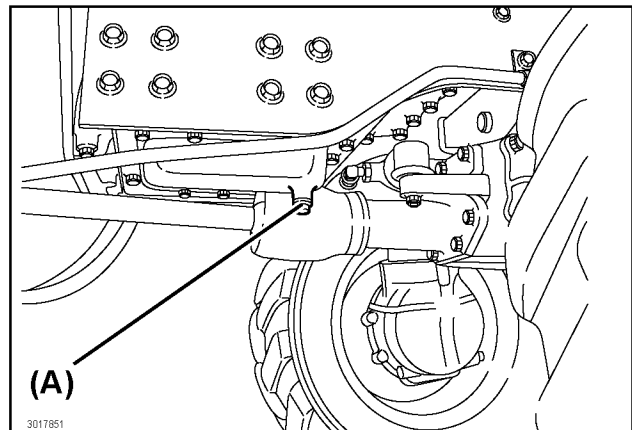

(A) Engine oil drain plug

⚠ CAUTION

When draining oil that is still hot:

- Stay clear of the hot oil and other engine parts in order to avoid getting burned.

14. PERIODIC SERVICE

- Remove the engine oil drain plug by turning counterclockwise.
- Allow the engine oil to drain completely from the engine.
- Wipe away the dirt and dust surrounding the engine oil filter.

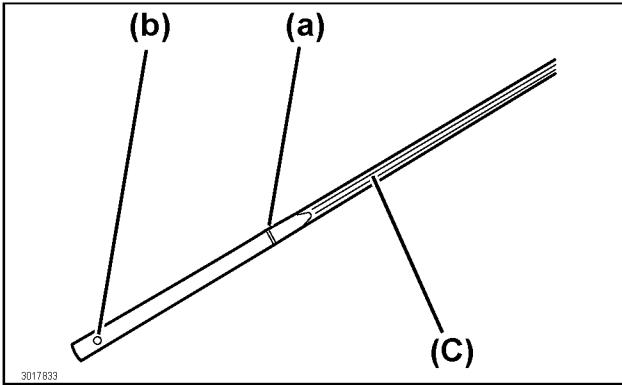
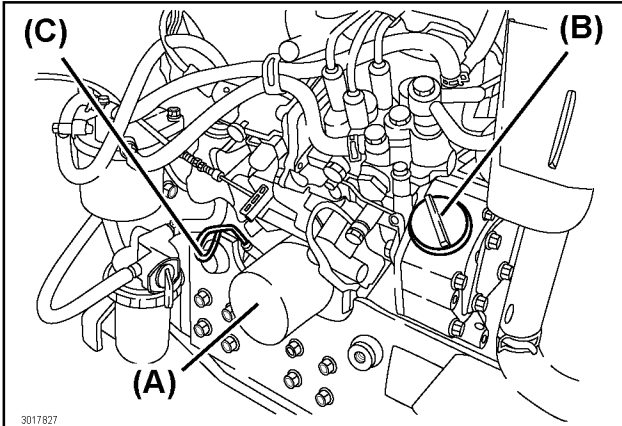

- (A) Engine oil filter
(B) Engine oil filler cap
(C) Dipstick
(a) Upper mark
(b) Lower mark

NOTE

- Carefully clean the area around the dipstick before removing the dipstick.

- Remove the engine oil filter by turning counterclockwise.
- Clean the area around engine oil filter mounting base.
- Apply a small amount of clean engine oil into the gasket of the new engine oil filter.
- Install the new engine oil filter by turning clockwise:
 - Until the gasket is seated against the engine oil filter base.
 - Turn the engine oil filter an additional half turn.
- Install the engine oil drain plug. Avoid over tightening.
- Remove the engine oil filler cap.

- Pour an approximately 3.9 qt. (3.6 L) of engine oil.
- Install the engine oil filler cap.
- Start and run the engine at idle to check for any leaks.
- Shut off the engine. Repair any leaks before operating the tractor.
- The engine oil level must be between the upper and lower marks on the dipstick. Add engine oil as necessary.
- Lower the hood.

■ Inspect and Adjust the Toe-in

NOTE

- The tractor's toe-in setting is factory preset and cannot be adjusted.
- Contact YOUR LOCAL YANMAR TRACTOR DEALER for technical assistance.

■ Check the Air Intake Hoses and Clamps

- Park the tractor safely and securely.
 - For details, see "7. Safe Practices for Parking the Tractor" on page 1-7.
- Shut off the engine.
- Chock all the tires safely and securely.
- Allow the engine to cool down for several minutes.
- Raise the hood.
- Check for loose clamps. As necessary, tighten the upper air intake hose clamp and the lower air intake hose clamp.
- Lower the hood.

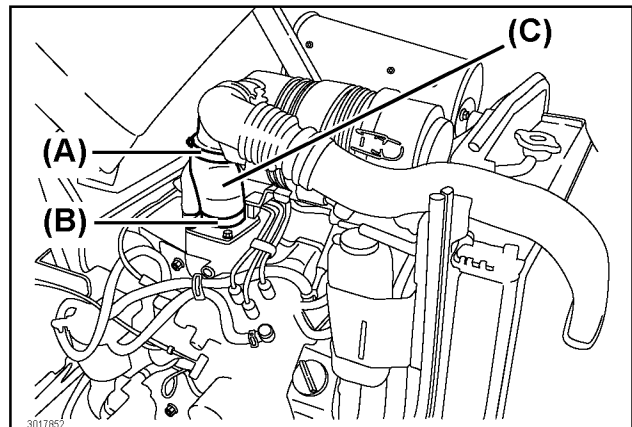

- (A) Upper air intake hose clamp
(B) Lower air intake hose clamp
(C) Air intake hose

8. Every 300 Hours

Transmission Hydraulic Oil

IMPORTANT

- Always use a Hydraulic/Transmission Fluid for the transmission hydraulic oil.

Transmission

Capacity	Lubricant
Approximately 4.6 US gal (17.6 L)	Hydraulic/Transmission Fluid

Change the Transmission Hydraulic Oil and Replace the Transmission Hydraulic Oil Filters and Clean Transmission Hydraulic Oil Strainer

⚠ WARNING

- Touching any hot surfaces can burn the skin.
- If the engine has been running for some time, the engine components, including all internal fluids are hot:
 - always allow the engine to cool down before performing maintenance or working near the engine and engine parts

IMPORTANT

- More frequent maintenance can be required under severe or abnormal conditions.
- Always keep the transmission hydraulic oil filler cap in place.
- Remove the transmission hydraulic oil filler cap only as necessary:
 - the preceding practice prevents the transmission hydraulic oil from becoming contaminated
 - a contaminated transmission hydraulic oil can cause damage to or failure of the transmission
- Avoid operating the tractor immediately after the transmission hydraulic oil is changed.
- After the transmission hydraulic oil is changed, run the engine at medium speed for a few minutes, to prevent damage to the transmission.

1. Park the tractor safely and securely.
 - For details, see "7. Safe Practices for Parking the Tractor" on page 1-7.
2. Run the engine to warm up the transmission hydraulic oil.
3. Shut off the engine.
4. Chock all the tires safely and securely.

5. Allow the engine to cool down for several minutes.

IMPORTANT

- Take the preceding information into consideration while draining the transmission hydraulic oil.

6. Place an oil pan underneath the transmission drain plug and the left and right rear axle drain plugs. Remove the transmission drain plug and the left and right rear axle drain plugs and allow the transmission hydraulic oil to drain completely.

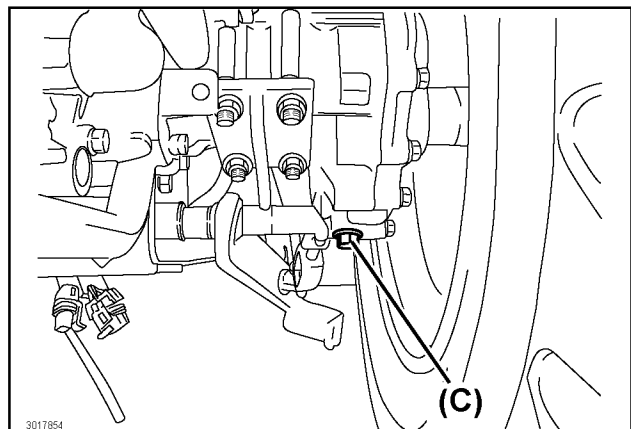
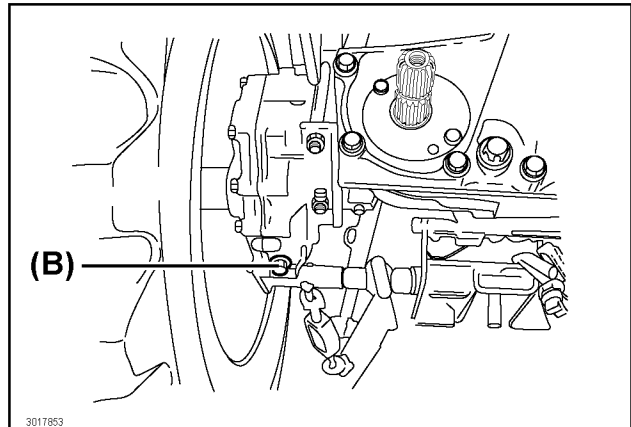
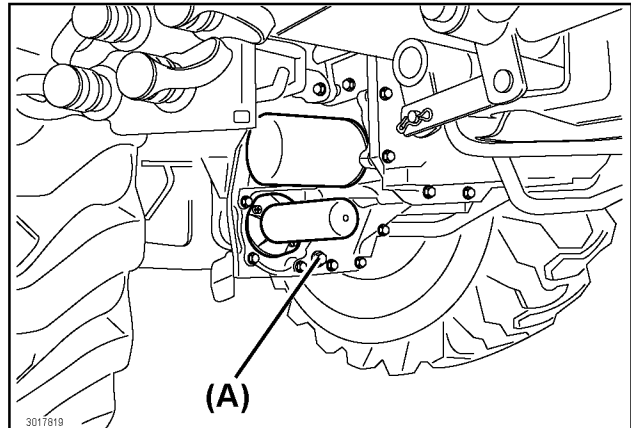

- (A) Drain plug (transmission)
 (B) Drain plug (rear right axle)
 (C) Drain plug (rear left axle)

14. PERIODIC SERVICE

7. Once the transmission hydraulic oil is completely drained.
8. Remove the 2 bolts from the transmission hydraulic oil strainer cover located on the rear of the tractor.
9. Remove the cover.
10. Pull out the transmission hydraulic oil strainer and the magnets from the transmission housing.
11. Clean the transmission hydraulic oil strainer, cover, O-ring and the magnets.
 - Use a mild solvent.
 - Allow the parts to dry.
12. Inspect the O-ring for any damages. Replace as necessary.
13. Install the magnets into the transmission hydraulic oil strainer.
14. Install the transmission hydraulic oil strainer, O-ring and transmission hydraulic oil strainer cover.
15. Install and tighten the 2 bolts.

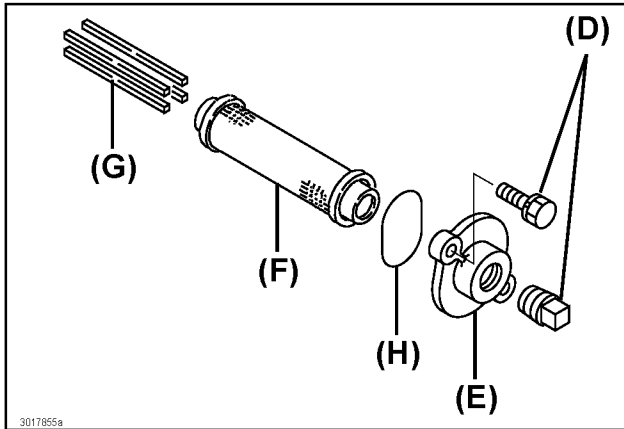

- (D) Bolts
(E) Transmission hydraulic oil strainer cover
(F) Transmission hydraulic oil strainer
(G) Magnets
(H) O-ring

16. Install the transmission drain plug and the left and right rear axle drain plugs. Tighten accordingly.
17. Place an oil pan underneath the transmission hydraulic oil filter on the left side of the transmission.
18. Remove the transmission hydraulic oil filter by turning counterclockwise using a filter wrench.
19. Remove the magnets from the transmission hydraulic oil filter.
20. Apply a small amount of clean transmission hydraulic oil into the gasket of the new transmission hydraulic oil filter.
21. Fill the transmission hydraulic oil filter with the designated type of transmission hydraulic oil to about 1/3 to 1/2 full.

22. Install the new transmission hydraulic oil filter by turning clockwise.
 - Continue turning until the gasket is seated against the transmission hydraulic oil filter base.
 - Turn the transmission hydraulic oil filter an additional of approximately 1/2 turn.

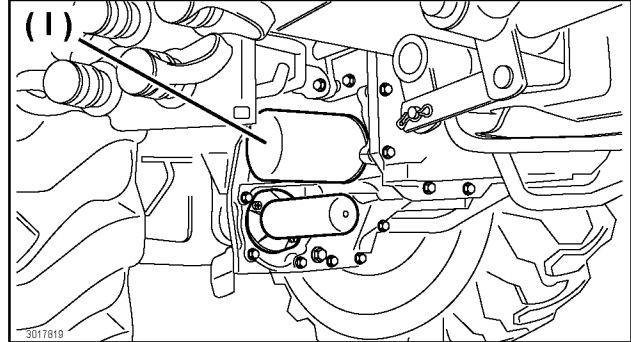

(I) Transmission hydraulic oil filter

IMPORTANT

To prevent dirt and other contaminants from entering the transmission:

- Carefully clean the area around the transmission hydraulic oil filler cap prior to removal.
- Avoid overfilling the transmission.
- Oil expands during operation and can overflow.

23. Remove the transmission hydraulic oil filler cap.
24. Add approximately 4.6 US gal (17.6 L) of transmission hydraulic oil through the transmission hydraulic oil filler opening.
25. Install the transmission hydraulic oil filler cap.
 - Start the engine.
 - Check for leaks around the transmission hydraulic oil filter base and the drain plugs.
 - Using the sight glass, check the transmission hydraulic oil level is in the correct operating range. The transmission hydraulic oil level on the sight glass should be 3/4. Add transmission hydraulic oil as necessary.

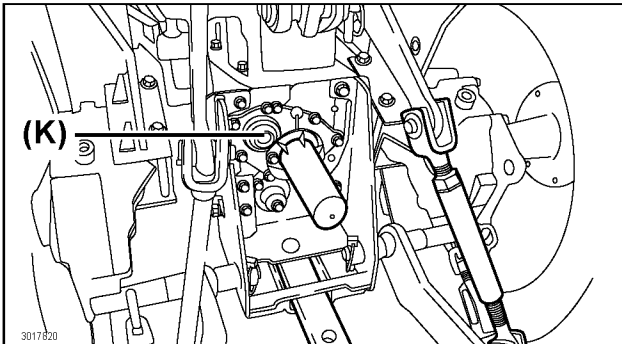
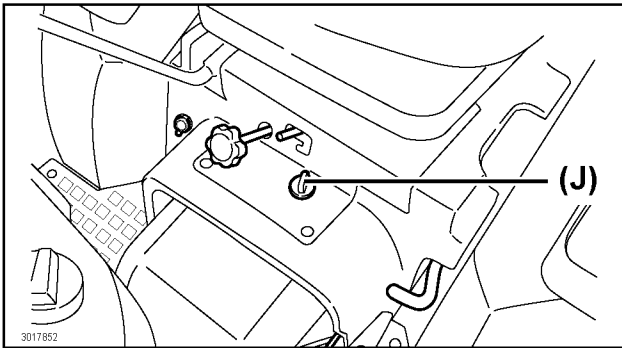

(J) Transmission hydraulic oil filler cap
(K) Sight glass

9. Every 500 Hours

Change the Front Axle Gear Oil

IMPORTANT

- Always use a SAE 80W-90 for the front axle.

Front Axle Gear Oil

Capacity	Lubricant
Approximately 1.03 US gal (3.9 L)	SAE 80W-90 gear oil

1. Drive the tractor to warm up the front axle gear oil.
2. Park the tractor safely and securely.
 - For details, see "7. Safe Practices for Parking the Tractor" on page 1-7.
3. Shut off the engine.
4. Check all the tires safely and securely.
5. Allow the engine to cool down for several minutes.
6. Remove the dipstick located on the right side of the front axle.
7. Place an oil pan underneath the drain plugs on both sides of front axle.
 - Remove the drain plugs.
 - Allow the front axle gear oil to drain completely.

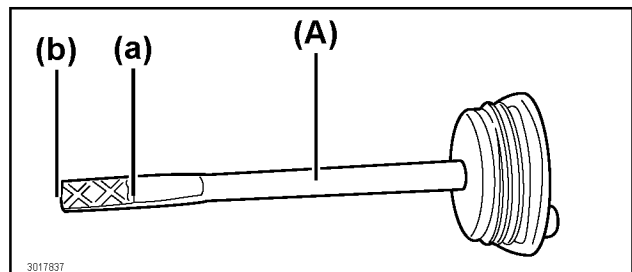
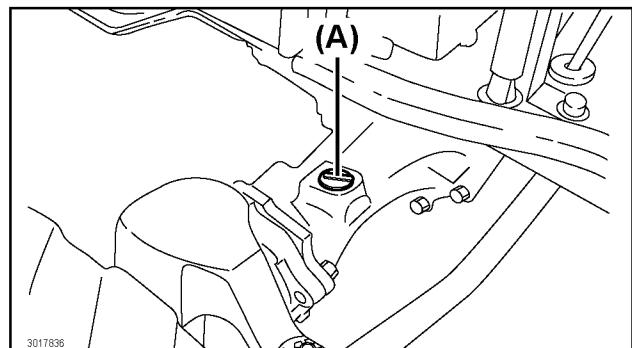

(A) Dipstick
(a) Upper mark
(b) Lower mark

14. PERIODIC SERVICE

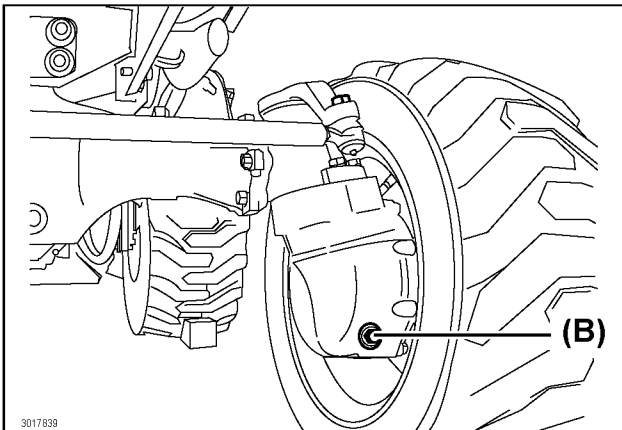
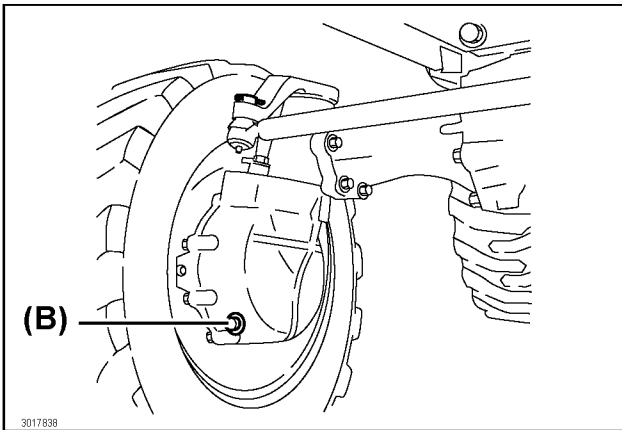

(B) Drain plugs

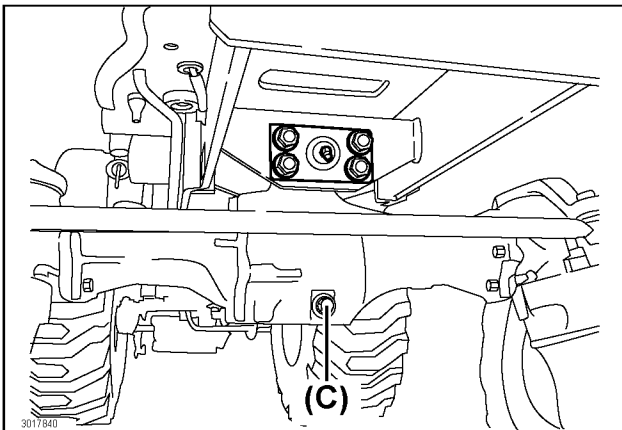

(C) Differential drain plug

8. Once the front axle gear oil is completely drained:
 - Install and tighten all the drain plugs.
9. Pour approximately 1.03 US gal (3.9 L) of SAE 80W-90 gear oil through the fill hole.
10. Insert and tighten the dipstick to the fill hole.
11. Allow the front axle gear oil settle for at least 1 hour.
12. Remove the dipstick from the fill hole.
13. Use a clean rag to wipe the front axle gear oil from the dipstick.

14. Insert the dipstick into the hole without tightening.

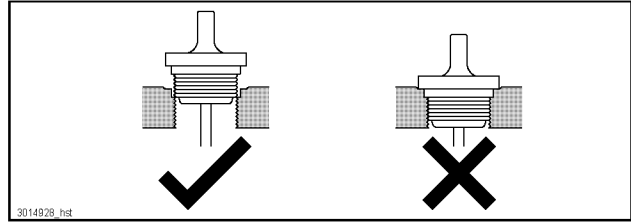

15. Remove the dipstick again.

16. Check the front axle gear oil level on the dipstick.

17. The front axle gear oil level must be between the upper and lower marks on the dipstick. Add front axle gear oil as necessary.

■ Replace the Fuel Filter

WARNING

Avoid injury!

Remember that diesel fuel vapor is explosive and flammable:

- Never smoke while handling diesel fuel.
- Keep the diesel fuel away from open flame or sparks.
- Before performing maintenance, shut off the engine and allow the engine to cool down.
- Work in a well ventilated area.
- Immediately wipe away any spilled diesel fuel.

NOTE

When replacing the fuel filter:

- Turn the fuel shut-off valve to OFF (closed) position to prevent the fuel from draining.
- Place an oil pan underneath the fuel filter.
- Clean the area around fuel filter base.
- Remove the fuel filter by turning counterclockwise using filter wrench.
- Apply a small amount of diesel fuel into the gasket of the new fuel filter.
- Install the new fuel filter by turning clockwise and hand tighten until the gasket is seated against the fuel filter base.
- Turn the fuel filter an additional of approximately 1/2 turn.
- Turn the fuel shut-off valve to ON (open) position.
- Turn the starter key switch to ON position.
- Wait at least 5 seconds to fill up the fuel filter.
- Start the engine.

IMPORTANT

When replacing the fuel filter:

- Turn the fuel shut-off valve to OFF (closed) position.

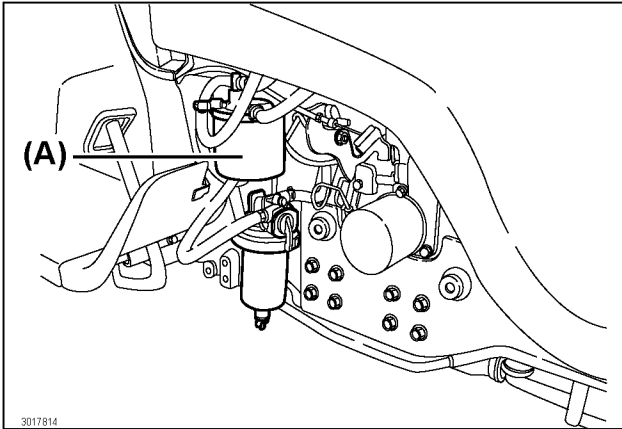

(A) Fuel filter

Adjust the Front Axle Pivot

CAUTION

If the front axle pivot is incorrectly adjusted:

- The front wheels can trigger a vibration which leads to steering wheel vibration.

Adjustment Procedure

1. Tighten the adjusting bolts to a torque of 57 to 72 ft•lbs (78 to 98 N•m).

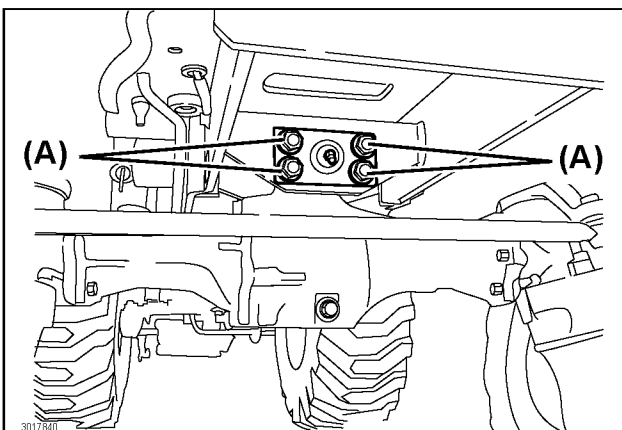

(A) Bolts

2. Make sure that the free play on the front axle in the forward/reverse direction. Check the free play using the spring scale 74 to 148 ft•lbs (100 to 200 N•m).

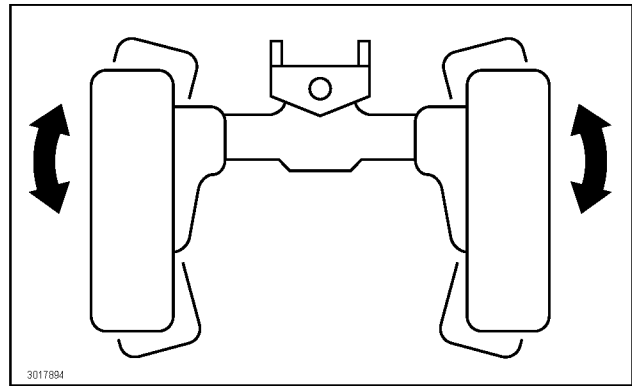

Adjust the Brake

Contact YOUR LOCAL YANMAR TRACTOR DEALER for technical assistance.

10. Every 1000 Hours

Service the Cooling System

⚠ WARNING

Avoid injury!

- Always allow the radiator to cool down:
 - the radiator is hot and can cause burns
 - the build up pressure in the cooling system can cause the coolant to spray out explosively during removal of the radiator cap
- Always shut off the engine.
- Allow the engine to cool down.
- Remove the radiator cap only when:
 - the radiator and the engine are sufficiently cooled down that can be touched with bare hands
- When removing the radiator cap, always:
 - loosen the radiator cap to the first stop
 - the preceding action releases excessive pressure on the radiator
 - fully remove the radiator cap once the pressure has been released completely
- For tractors equipped with a coolant reserve tank:
 - add coolant or water to reserve tank, not to the radiator, for details, see "Check the Cooling System" on page 14-14

1. Drain the Cooling System

1. Park the tractor safely and securely.
 - For details, see "7. Safe Practices for Parking the Tractor" on page 1-7.
2. Shut off the engine.
3. Chock all the tires safely and securely.
4. Allow the engine to cool down for several minutes.
5. Raise the hood.
6. Remove the radiator cap to speed up the draining of the coolant.
 - Loosen the radiator cap to the first stop.
 - the preceding action releases excessive pressure on the radiator
 - Fully remove the radiator cap once the pressure has been released completely.
7. Place a drain pan underneath the engine drain plug and radiator petcock.
8. Remove the engine drain plug and open the radiator petcock.
9. Drain the coolant completely.

10. Install the engine drain plug.

11. Close the radiator petcock.

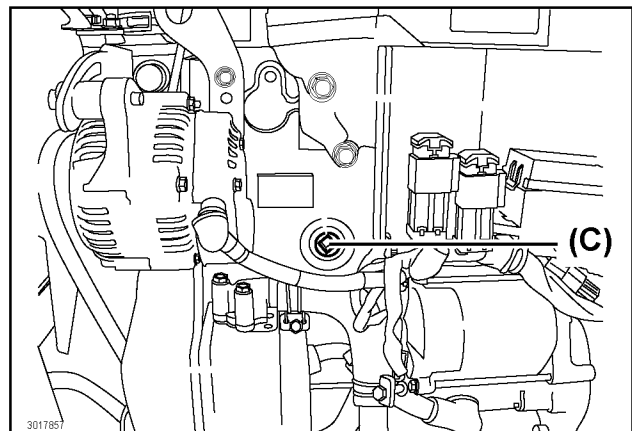
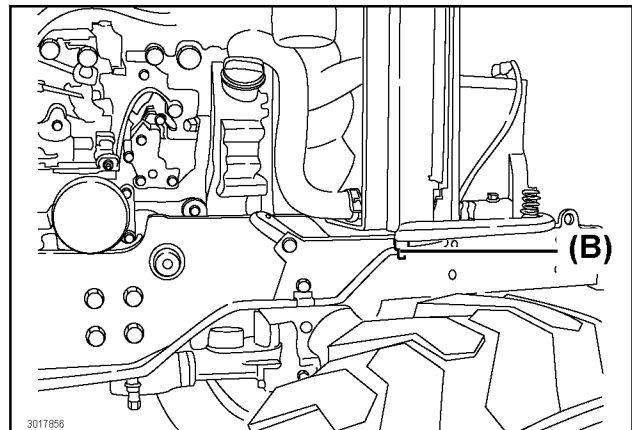
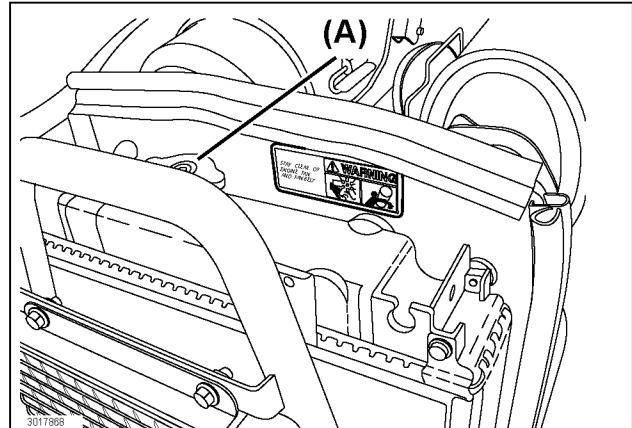

(A) Radiator cap
(B) Radiator petcock
(C) Engine drain plug

2. Flush the Cooling System

1. Fill the cooling system with water and common flushing/cooling liquid.
 - Follow the manufacturer's instructions.
2. Install and tighten the radiator cap.
3. Start and run the engine until the operating temperature is reached.

⚠ WARNING

Avoid injury!

- Touching hot surfaces can burn skin.
- If the engine has been running for some time, the engine components are hot including all internal fluids.
- Before performing maintenance or working near the engine and engine parts:
 - allow the engine to cool down
 - always wear protective goggles and protective clothing

4. Shut off the engine.
5. Open the radiator petcock.
6. Place a drain pan underneath the engine coolant drain plug.
7. Remove the engine drain plug.
8. Immediately drain the flushing/cooling liquid.
 - The preceding practice prevents rust and dirt from settling down.
 - Make sure to avoid touching and getting in contact with hot engine components and hot internal fluids.
9. Close the radiator petcock.
10. Install the engine drain plug.

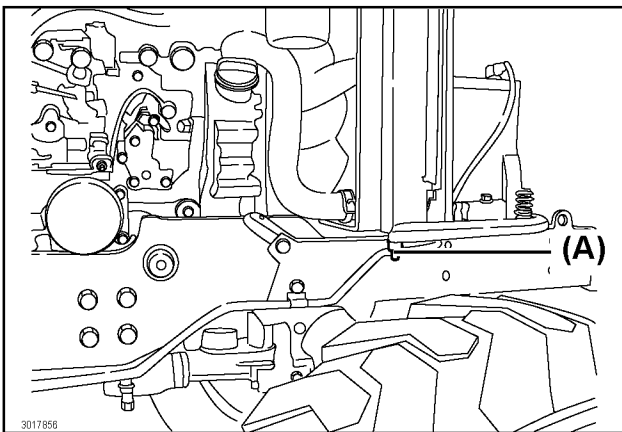

(A) Radiator petcock

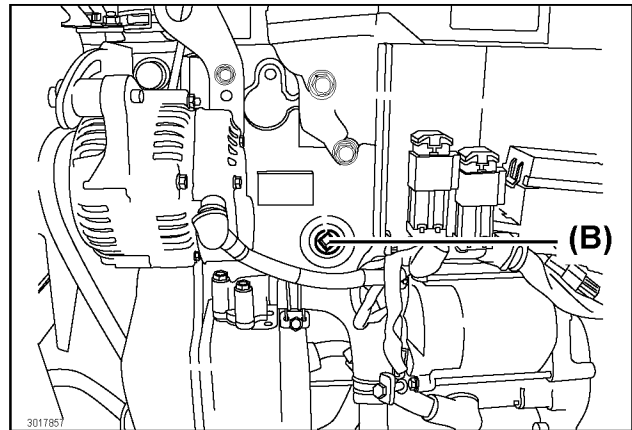

(B) Engine drain plug

3. Fill the Cooling System

IMPORTANT

- Use correct coolant mixture to prevent damage to the cooling system.
- Avoid operating the engine with plain water in the cooling system.
- Always use a pre-diluted coolant, with an antifreeze water mixture ratio that suits the local climate.
- Allow the engine to cool down first before pouring the coolant.

NOTE

When adding coolant to the cooling system:

- Use of High Quality Permanent Type Antifreeze (Ethylene Glycol with corrosion and rust inhibitor chemicals) is recommended.
- For the correct mixture ratio, read the manufacturer's direction on the coolant container.

1. Allow the radiator to cool down.
2. Fill the cooling system with approximately 4.0 qt. (3.9 L) of coolant.

3. Install and tighten the radiator cap.
4. Start and run the engine until the operating temperature is reached.
5. Shut off the engine.
6. Check the reserve tank coolant level.
7. Add coolant as necessary.
8. Lower the hood.

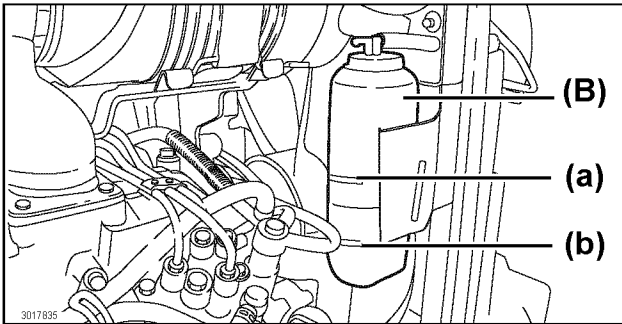
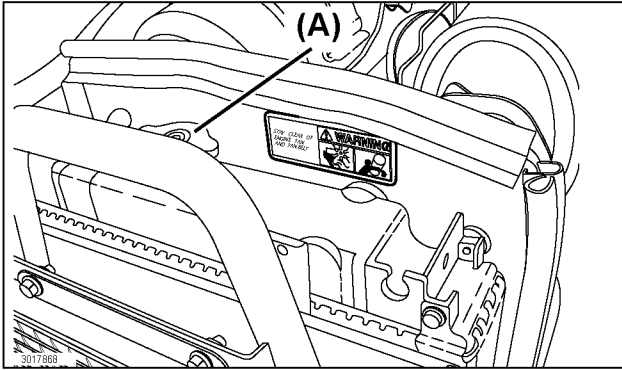

(A) Radiator cap
 (B) Reserve tank
 (a) FULL line
 (b) LOW line

■ Recommended Engine Coolant

The Following Coolant is Recommended

- High Quality Permanent Type Antifreeze (Ethylene Glycol with corrosion and rust inhibitor chemicals).
- Before using the coolant:
 - read and understand the instructions and data on the coolant's container
 - make sure that the coolant is suitable for the engine
- Immediately after purchasing the tractor:
 - make sure that the blend ratio of the coolant is in accordance with the climate of the work area
 - the preceding practice contributes to make the entire tractor system function normally
- Replace the coolant in the following cases:
 - after 1000 hours of operation or 2 years whichever comes first
 - the cooling system is flushed

Follow the instructions on the antifreeze container or contact YOUR LOCAL YANMAR TRACTOR DEALER for technical assistance.

- Avoid exceeding the maximum dilution ratio for the coolant.
- Exceeding the preceding ratio can jeopardize the effectiveness of the coolant.

■ Adjust the Tension of the Throttle Control Lever

Contact YOUR LOCAL YANMAR TRACTOR DEALER for technical assistance.

■ Adjust the Engine Valve Clearance

Contact YOUR LOCAL YANMAR TRACTOR DEALER for technical assistance.

■ Check the Fuel Injection Nozzle

Contact YOUR LOCAL YANMAR TRACTOR DEALER for technical assistance.

■ Check the Fuel Injection Pump

Contact YOUR LOCAL YANMAR TRACTOR DEALER for technical assistance.

11. Every 1 Year

■ Replace the Air Cleaner Element

For the maintenance work, see "Service the Air Cleaner Element" on page 14-21.

12. Every 2 Years or 2000 Hours

■ Replace the Thermostat

Contact YOUR LOCAL YANMAR TRACTOR DEALER.

13. General Maintenance

WARNING

Avoid injury!

- The rubber product/s has/have a deteriorative character. The deteriorated rubber product/s may cause defects and damages such as fluid leakage, loss control of the tractor during operation, fire, burn injury.

NOTE

- Replace the air cleaner element at least once a year.
- Replace the coolant once every 2 years or 1000 hours.
- Replace the radiator hoses at least once every 2 years.
- Replace the fuel hoses at least once every 2 years.
- Replace the air intake hose at least once every 2 years.
- Replace the power steering hoses at least once every 2 years.

15. SERVICE THE ELECTRICAL SYSTEM

WARNING

Avoid injury:

- Read "Chapter 1. SAFETY PRECAUTIONS".
- Read the DANGER, WARNING AND CAUTION statements on the safety alert decals on the tractor.
- To prevent poisoning from engine exhaust fumes, always operate the engine in a well ventilated area.
- Always remain seated on the operator seat.
- Avoid bystander/s near the tractor.
- Before starting the engine:
 - the parking brake lock is engaged
 - release the forward and reverse drive pedals completely
 - range gear lever is in the N (neutral) position
- Push down Power Take Off (PTO) switch to OFF position.

1. Battery

WARNING

- The battery posts, terminals and associated accessories contain lead and lead compounds that are known to the State of California to cause cancer and reproductive harm.
- After handling the battery, wash the hands thoroughly.

■ Service the Battery Safely

WARNING

Avoid injury:

- The battery electrolyte contains sulfuric acid that is poisonous and can cause serious burns.
- Wear protective goggles and gloves.
- Avoid getting the skin in contact with the battery electrolyte.
- If the battery electrolyte comes into contact with the skin:
 - immediately flush with plenty of water
 - seek medical attention as necessary
- If electrolyte is accidentally swallowed, immediately seek medical attention.
- If the electrolyte gets in the eyes:
 - immediately flush with running water for 15-30 minutes
 - seek medical attention
- Battery can emit flammable/explosive gasses.
- Use extreme caution when handling batteries.
- Keep cigarette and other flames far away from the battery.
- Avoid placing any metal piece across the battery posts.
- Disconnect the negative (-) battery terminal first during removal of batteries.
- Connect the positive (+) battery terminal first during installation of batteries.

NOTICE

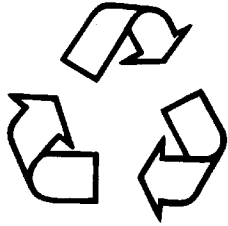

- Always observe environment protection laws.
- Dispose of (possibly) hazardous materials in accordance with the guidelines of the Environmental Protection Agency (EPA) and other relevant governmental bodies.
- The hazardous materials in the tractor include:
 - engine oil
 - diesel fuel
 - transmission hydraulic oil
 - battery
 - coolant
 - front axle gear oil
- Exercise good judgment in deciding what is and what is not hazardous.
- Dispose hazardous materials only in waste disposal facilities designated by local authorities.
- Never dispose the hazardous wastes in inappropriate locations, e.g., sewer, ground, groundwater, waterways.
- Failure to follow these instructions can adversely impact the environment and can be unlawful.

■ Inspect the Battery

1. The battery that comes with the new tractor is a maintenance free design.
2. Avoid adding electrolyte.
3. Avoid recharging the battery.
4. Measure the voltage on the battery across the positive (+) and negative (-) posts while the engine is shut off.
5. If the reading is 11V or lower, replace the battery with a new one.

■ Remove and Install the Battery

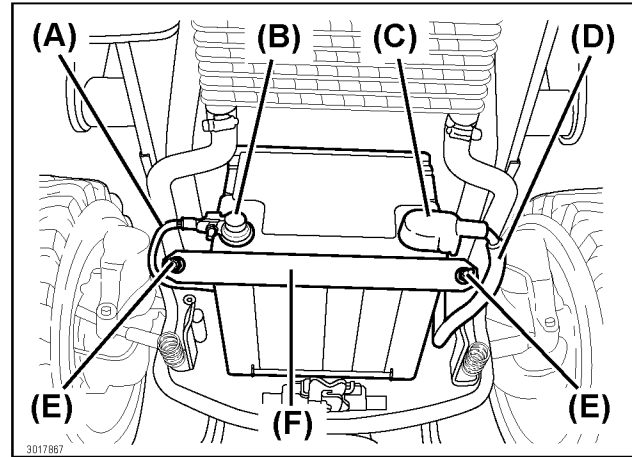

- (A) *Negative (-) cable*
- (B) *Negative (-) terminal*
- (C) *Positive (+) terminal red cover*
- (D) *Positive (+) cable*
- (E) *Threaded rods*
- (F) *Bracket*

1. Remove the Battery

1. Park the tractor safely and securely.
 - For details, see "7. Safe Practices for Parking the Tractor" on page 1-7.
2. Shut off the engine.
3. Chock all the tires safely and securely.
4. Allow the engine to cool down for several minutes.
5. Raise the hood.
6. Disconnect the negative (-) battery terminal.
7. Pull up the positive (+) terminal red cover.
8. Disconnect the positive (+) battery terminal.
9. Remove the nuts, washer faced nuts, the threaded rods and the bracket.
10. Remove the battery.

2. Install the Battery

1. Install the battery onto the tractor.
2. Check that the battery is properly seated against the backstop.
3. Position the threaded rods and the bracket on each side of the battery.
4. Tighten the washer faced nuts and the nuts on each threaded rods.
5. Avoid over tightening the washer faced nuts and the nuts.
6. Connect the positive (+) battery terminal.
7. Connect the negative (-) battery terminal.
8. Apply petroleum jelly or silicon spray to the battery terminals to protect the terminals against corrosion.

15. SERVICE THE ELECTRICAL SYSTEM

9. Push down the positive (+) terminal red cover.
 - Make sure that the positive (+) battery terminal is covered completely.
10. Lower the hood.

■ Clean the Battery and Terminals

1. Park the tractor safely and securely.
 - For details, see "7. Safe Practices for Parking the Tractor" on page 1-7.
2. Shut off the engine.
3. Chock all the tires safely and securely.
4. Allow the engine to cool down for several minutes.
5. Raise the hood.
6. Remove the battery.
 - For details, see "Remove the Battery" on page 15-1.
7. Dissolve four tablespoons of baking soda in 4 qt. (3.8 L) of water to prepare a solution.
 - Use the solution to wash the battery.
 - Be very careful to prevent the solution to enter the battery cells.
8. Rinse the battery with water and allow to dry.
9. Clean the terminals and battery cable ends with a wire brush to remove corrosion.
10. Apply petroleum jelly or silicon spray to the battery terminals to protect against corrosion.
11. Install the battery.
 - For details, see "Install the Battery" on page 15-2.

■ Use a Booster Battery

WARNING

Avoid injury!

- Never attempt to jump start a frozen battery.
- Warm the battery to 60 °F (16 °C) first.
- Never connect the negative (–) booster cable to the negative (–) battery terminal of the discharged battery.
- Connect the negative (–) booster cable to an appropriate grounding point other than the discharged battery.
- The battery may emit flammable gases.
- Gases explodes, as the gas gets in contact with spark or open flame.
- Do not smoke or have an open flame near the battery.

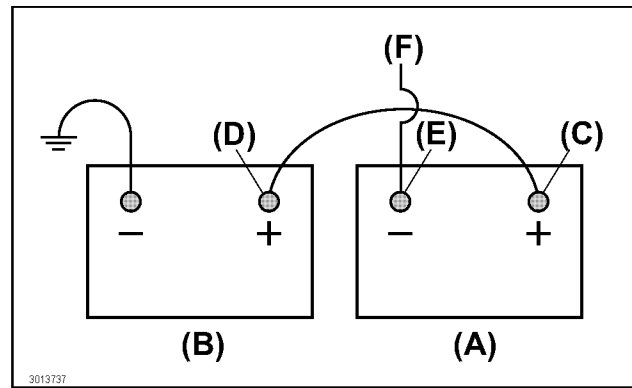

- (A) Booster battery*
(B) Battery on a disabled tractor
(C) Positive (+) post of booster battery
(D) Positive (+) battery terminal on a disabled vehicle
(E) Negative (-) post of booster battery
(F) Other end of negative (-) booster cable

1. Park the abled tractor close enough besides the disabled tractor.
2. Raise the hood of the disabled and abled tractors.
3. Connect one end of the positive (+) booster cable to the positive (+) post of booster battery.
4. Connect the other end of positive (+) booster cable to the positive (+) battery terminal on the disabled tractor.
5. Connect one end of the negative (–) booster cable to the negative (–) post of booster battery.
6. Connect the other end of the negative (–) booster cable to the engine block of the disabled tractor.
7. Start the engine of the abled tractor.
8. Start the engine of the disabled tractor.
9. Run the engine of both disabled and abled tractors for several minutes.
10. Check the alternator/battery charging light of the disabled tractor.

IMPORTANT

- If alternator/battery charging light illuminates:
 - shut off the engine of the disabled tractor
 - contact YOUR LOCAL YANMAR TRACTOR DEALER for technical assistance

11. Carefully disconnect the booster cables:
 - Perform the disconnection of the booster cables from the abled and disabled tractors by doing the reverse of the preceding procedure.
 - Make sure to disconnect the negative (–) booster cable first before the positive (+) booster cable.
12. Keep running the engine of the disabled tractor for not less than 10 min.

2. Fuses

IMPORTANT

- Use of a fuse other than a correctly rated one can damage the electrical system.
- Replace blown fuse with a new fuse of the same ampere rating only after fixing the problem.

■ Replace the Accessory Fuses

1. Park the tractor safely and securely.
 - For details, see “7. Safe Practices for Parking the Tractor” on page 1-7.
2. Shut off the engine.
3. Chock all the tires safely and securely.
4. Allow the engine to cool down for several minutes.
5. Raise the hood.
6. Grip both ends of the fuse holder cover and remove the cover.
7. Locate the fuses, refer to the illustration shown.
8. Remove the blown fuse from its socket.
9. Check and fix the problem of the blown fuse.
10. Insert the new fuse into the socket.
11. Install the fuse holder cover.
12. Lower the hood.

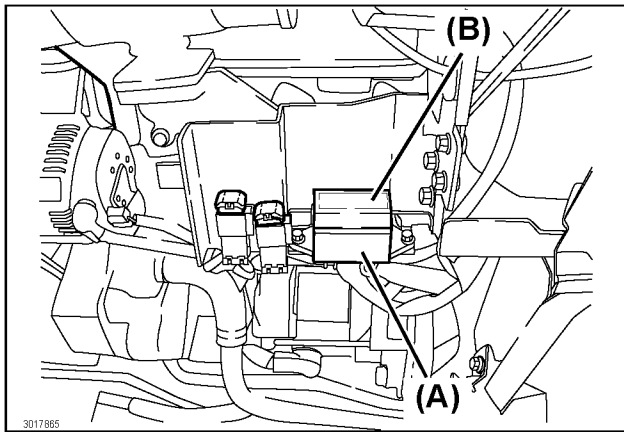

(A) Fuse holder
(B) Fuse holder cover

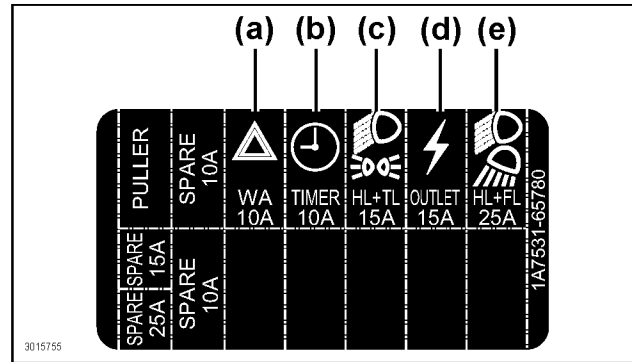

- (a) Indicator light fuse: 10A
 (b) Timer relay fuse: 10A
 (c) Headlight/Tail lights fuse: 15A
 (d) 12V DC outlet fuse: 15A
 (e) Flasher unit fuse: 25A

■ Check the Alternator Fuse and the Main Fuse

1. Park the tractor safely and securely.
 - For details, see “7. Safe Practices for Parking the Tractor” on page 1-7.
2. Shut off the engine.
3. Chock all the tires safely and securely.
4. Allow the engine to cool down for several minutes.
5. Raise the hood.
6. Locate the fuses, refer to the illustration shown.
7. Check the fuses.

IMPORTANT

- The alternator fuse and the main fuse are slow blow type.
- When any of the fuses is blown, contact YOUR LOCAL YANMAR TRACTOR DEALER.

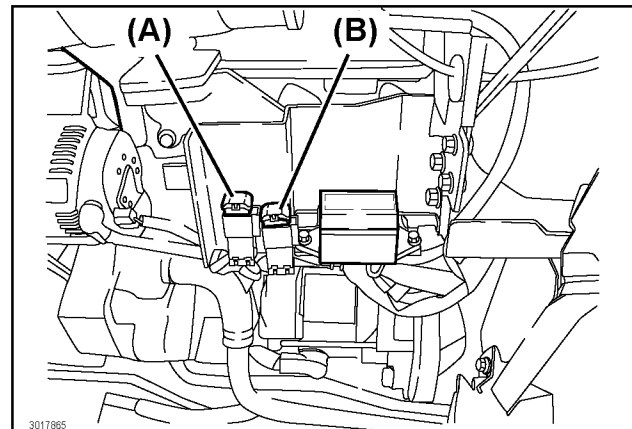

(A) Alternator fuse: 80A
(B) Main fuse: 80A

3. Bulb

IMPORTANT

- Replace blown bulbs with new Yanmar genuine spare bulb only.

■ Replace the Headlight Bulb

IMPORTANT

- Keep bare fingers away from the headlights bulb.
- While inspecting or replacing the headlights bulb, use gloves or a piece of cloth to handle the headlights bulb.

1. Park the tractor safely and securely.
 - For details, see “7. Safe Practices for Parking the Tractor” on page 1-7.
2. Shut off the engine.
3. Chock all the tires safely and securely.
4. Allow the engine to cool down for several minutes.
5. Remove the key.
6. Raise the hood.
7. Disconnect the wire harness connector.
8. Remove the boot.
9. Unlock the retaining ring.

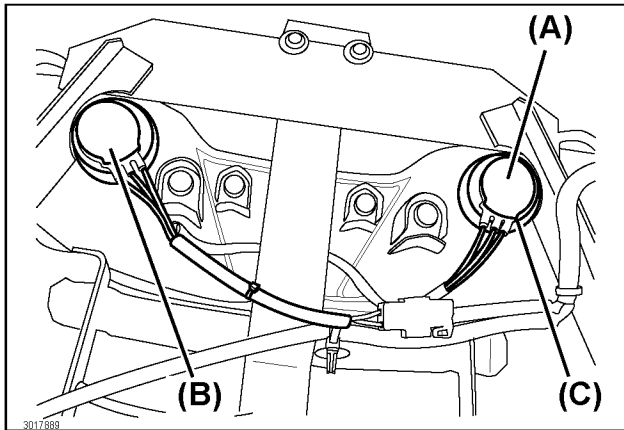

(A) Wire harness connector
(B) Headlight bulb assembly
(C) Boot

⚠ WARNING

- The halogen light bulb contains compressed gas. If the glass has been scratched or dropped, the bulb may shatter. Wear protective goggles and handle the bulb carefully when replacing halogen light bulb.

10. Remove the headlights bulb from the socket.
11. Insert the new headlights bulb into the socket.
12. Lock the retaining ring and install the boot.
13. Connect the wire harness connector to the headlights bulb.
14. Turn the starter key switch to ON position.
15. Turn ON headlights switch.
16. Make sure the headlight bulbs are functioning.
17. Lower the hood.

■ Replace the Tail Lights Bulb and the Turn Signal/Hazard Lights Bulb

NOTE

- The tail light assembly can be serviced after removing the rear lens assembly.

1. Park the tractor safely and securely.
 - For details, see “7. Safe Practices for Parking the Tractor” on page 1-7.
2. Shut off the engine.
3. Chock all the tires safely and securely.
4. Allow the engine to cool down for several minutes.
5. Remove the key.
6. Remove the two screws and lens from the tail lights housing.
7. Remove the bulb.
 - Pull the failed tail lights bulb to remove from the socket.
 - Push up and rotate failed turn signal/hazard light bulb to remove from the socket.
8. Install the new bulb.
 - Insert new tail lights bulb to the socket.
 - Push up and rotate new turn signal/hazard light bulb to the socket.
9. Turn the starter key switch to ON position.
10. Make sure the tail lights bulbs and turn signal/hazard light bulb are functioning.
11. Install the lens and screws.

IMPORTANT

- ALWAYS use genuine bulbs which are certified by Yanmar as safe to use.
- ALWAYS insert the bulb into the proper socket.

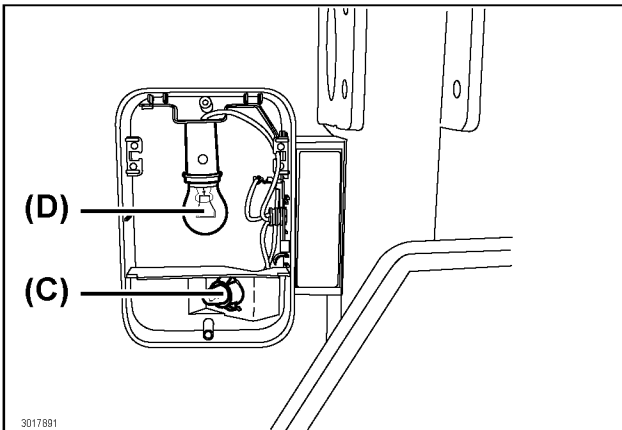
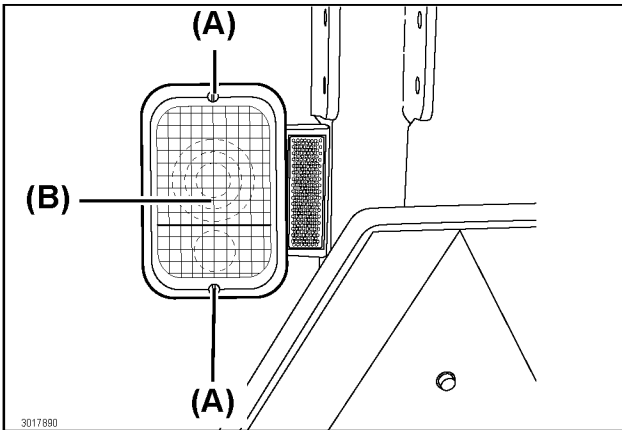

- (A) Screws
- (B) Lens
- (C) Tail lights bulb
- (D) Turn signal/hazard lights bulb

■ Replace the Sidelights Bulb

1. Park the tractor safely and securely.
 - For details, see "7. Safe Practices for Parking the Tractor" on page 1-7.
2. Shut off the engine.
3. Chock all the tires safely and securely.
4. Allow the engine to cool down for several minutes.
5. Remove the key.
6. Turn counterclockwise the sidelight socket to remove the sidelight socket from the sidelight housing.
7. Remove the sidelight bulb from the sidelight socket.
8. Install a new sidelight bulb into the sidelight socket.
9. Turn clockwise the sidelight socket to install the sidelight socket into the sidelight housing.
10. Lower the hood.
11. Make sure the turn sidelights are functioning.

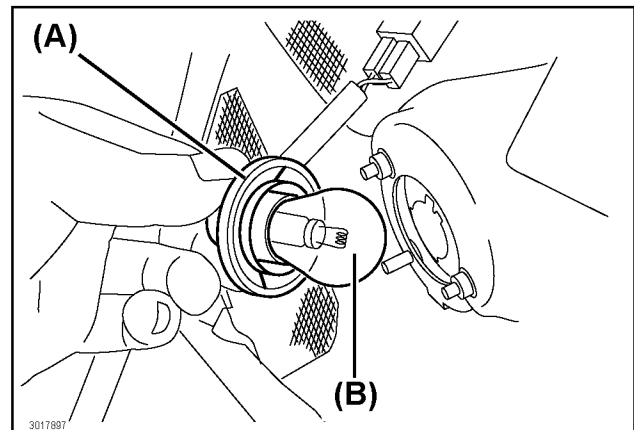

- (A) Sidelight socket
- (B) Sidelight bulb

■ Replace the Instrument Panel Light Bulb

1. Park the tractor safely and securely.
 - For details, see "7. Safe Practices for Parking the Tractor" on page 1-7.
2. Shut off the engine.
3. Chock all the tires safely and securely.
4. Allow the engine to cool down for several minutes.
5. Remove the key.
6. Remove the steering wheel.
7. Remove the throttle control lever.
8. Remove the instrument panel.
9. Remove the instrument panel back cover from the instrument panel.

10. Locate the failed instrument panel light bulb.
11. Pull out the failed instrument panel light bulb from the bulb holder.
12. Push in a new instrument panel light bulb into the bulb holder.
13. Install the instrument panel back cover into the instrument panel.
14. Make sure the instrument panel lights are functioning.
15. Install the instrument panel housing.
16. Install the throttle control lever.
17. Install the steering wheel.

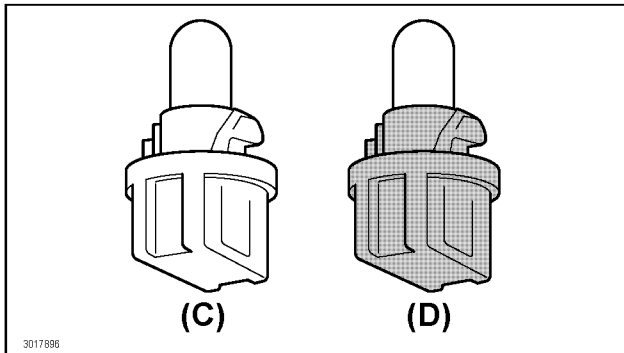
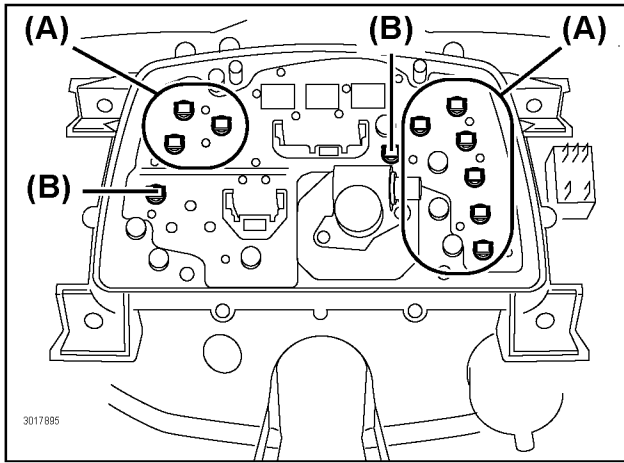

- (A) Bulb holder (blue)
(B) Bulb holder (black)
(C) Instrument panel light bulb (blue): 2.0W
(D) Instrument panel light bulb (black): 1.4W

4. Headlights

■ Adjust the Headlights

1. The headlights are not adjustable.
2. If headlights adjustment is required, contact YOUR LOCAL YANMAR TRACTOR DEALER for technical assistance.

16. STORAGE

1. Safe Practices for Storage

WARNING

- Remember that vapor from diesel fuel is explosive and flammable.
- The exhaust from the engine contains carbon monoxide that can lead to carbon monoxide poisoning, possibly causing serious illness or even death. To avoid the danger of poisoning from the exhaust gas, never run the engine in a closed area that is not correctly ventilated.
- Never wash the tractor while the engine is running.
- Run the engine as short as possible when moving the tractor to and from the place of storage.
- If the fuel tank is filled with fuel, never store the tractor in an area where fuel vapor can come into contact with open flame or spark.
- Before storing the tractor indoor, allow the engine to cool off.

1. Prepare the Tractor for Storage

- If planning to store the tractor for a long period, follow the procedure described below.
 - The procedure is intended to ensure that the tractor is readily prepared for operation when the tractor is removed from storage.
1. Repair any worn out or damaged parts.
 2. Replace parts as necessary.
 3. Tighten any loose bolts and nuts.
 4. Repair scratched or chipped metal surfaces to prevent rusting.
 5. Remove grass clippings and debris from the tractor.
 6. Clean below the platform.
 7. Remove grass clippings and debris from inside the chute and bagger.
 8. Remove all attached weight and ballast from the tractor.
 9. Wash the tractor and apply wax to the metal and plastic surfaces.

10. Run the tractor for 5 minutes to dry the alternator/ fan belt and pulleys.
11. Apply a light coat of clean engine oil to pivots and wear points to prevent rusting.
12. Lubricate the grease fittings.
13. Completely remove the liquid weights from the rear tires.
14. Check the tire air pressure. Adjust the tire air pressure slightly higher than specified.
15. Change the engine oil and run the engine for about 5 minutes to circulate the engine oil throughout the entire engine block and the internal moving parts.
16. Lower any implement to the ground.
17. Apply grease to the exposed areas on the hydraulic cylinder piston rods.

2. Prepare the Fuel and Engine for Storage

■ Fuel

1. If stabilized fuel was used:
 - Fully fill the fuel tank with stabilized fuel.

NOTE

- Fill the fuel tank.
- The preceding action:
 - decreases the amount of air remaining in the fuel tank
 - prevent deterioration of the fuel in the fuel tank

2. If stabilized fuel is not used.
 - Park the tractor safely and securely in a well ventilated place.
 - Chock all the tires safely and securely.

NOTE

- Use up all the fuel in the fuel tank when the tractor is operated for the last time in the current season.

3. Run the engine until all the fuel in the fuel tank is used up.
4. Turn the starter key switch to the OFF position.

IMPORTANT

- In degraded fuel:
 - varnish may be created
 - may clog the fuel injector components
 - adversely affect engine performance
- Mix a stabilizer into fresh fuel before filling the fuel tank.

5. Mix fresh fuel and fuel stabilizer in a separate container.
 - Observe the stabilizer manufacturer's instructions for mixing.
6. Fill the fuel tank with the stabilized fuel.
7. Run the engine for several minutes to allow the fuel stabilizer mixture to be circulated through the fuel system.

■ Engine

If the tractor is to be stored for longer than 60 days, prepare the engine for storage.

1. Change the engine oil and engine oil filter while the engine is still warm.
2. Clean the air filter as necessary.
3. Remove dust and debris from the engine air intake screen.
4. Clean the engine and engine compartment.
5. Remove the battery.
6. Clean the battery and battery posts.
7. Check the electrolyte level.
8. Turn the fuel shut-off valve to OFF (closed) position.
9. Store the battery in a cool, dry, dark place.
 - The temperature of the place must not become low enough to freeze the electrolyte in battery.
10. Store the tractor in a dry and safe place.
11. If the tractor is stored outdoors, protect the tractor with a waterproof cover.
12. Jack up the tractor and place blocks under the front and rear axles to lift the tires off the ground.

13. Do not expose the tires to direct sunlight or extremely high temperature.

2. Prepare the Stored Tractor for Operation

1. Check the tire air pressure. As necessary, refill with compressed air.
2. Check the levels of engine oil, transmission hydraulic oil and coolant.
3. Check the battery electrolyte level.
4. Make sure the battery has required voltage (12V).
5. Install the battery.
6. Check the alternator/fan belt tension.
7. Lubricate all the grease fittings.
8. Turn the fuel shut-off valve to ON (open) position.
9. Run the engine for 5 minutes to allow the oil to be fully distributed throughout the entire engine.
10. After stopping the engine, walk around the tractor and check for any evidence of oil or other leakage.
11. Make sure all the shields, guards or deflectors are in place.

17. TROUBLESHOOTING

1. How to Use the Troubleshooting Table

The troubleshooting table given below is quick reference for solving common problems. If any fault, failure or a problem requiring repair work is found, contact YOUR LOCAL YANMAR TRACTOR DEALER for technical assistance.

1. Engine

The problem is:	The possible cause(s) are:	Remedy:																									
<p>The engine is hard to start or does not start at all</p>	<p>1. A problem in the electrical</p>	<p>1. Electrical system</p> <ul style="list-style-type: none"> • Check whether the battery is fully charged. <ul style="list-style-type: none"> • charge the battery • Check whether the fuse/s is/are blown. <ul style="list-style-type: none"> • replace the blown fuse/s • Check for loose or corroded the battery terminals and battery cables. <ul style="list-style-type: none"> • tighten the loose battery terminals • clean the corroded battery terminals and battery cables • Check whether the start relay is faulty. <ul style="list-style-type: none"> • replace start relay • Check whether the starter key switch is faulty. <ul style="list-style-type: none"> • contact YOUR LOCAL YANMAR TRACTOR DEALER • Check whether the starter is faulty. <ul style="list-style-type: none"> • contact YOUR LOCAL YANMAR TRACTOR DEALER • Check whether the glow plug is faulty. <ul style="list-style-type: none"> • contact YOUR LOCAL YANMAR TRACTOR DEALER • Check whether the interface combination functions correctly. <div style="text-align: center;"> <table border="1" data-bbox="1084 1356 1336 1608"> <tr> <td style="text-align: center;">SWITCH</td> <td></td> <td></td> <td></td> <td></td> </tr> <tr> <td></td> <td style="writing-mode: vertical-rl; transform: rotate(180deg);">SEAT-ON</td> <td style="writing-mode: vertical-rl; transform: rotate(180deg);">FORWARD/REVERSE-N</td> <td style="writing-mode: vertical-rl; transform: rotate(180deg);">PTO-N</td> <td style="writing-mode: vertical-rl; transform: rotate(180deg);">PARKING BRAKE</td> </tr> <tr> <td style="text-align: center;">ENGINE</td> <td></td> <td></td> <td></td> <td></td> </tr> <tr> <td style="text-align: center;">START 1</td> <td style="text-align: center;">○</td> <td style="text-align: center;">○</td> <td style="text-align: center;">○</td> <td></td> </tr> <tr> <td style="text-align: center;">START 2</td> <td></td> <td style="text-align: center;">○</td> <td style="text-align: center;">○</td> <td style="text-align: center;">○</td> </tr> </table> </div> <ul style="list-style-type: none"> • contact YOUR LOCAL YANMAR TRACTOR DEALER 	SWITCH						SEAT-ON	FORWARD/REVERSE-N	PTO-N	PARKING BRAKE	ENGINE					START 1	○	○	○		START 2		○	○	○
SWITCH																											
	SEAT-ON	FORWARD/REVERSE-N	PTO-N	PARKING BRAKE																							
ENGINE																											
START 1	○	○	○																								
START 2		○	○	○																							

17. TROUBLESHOOTING

The problem is:	The possible cause(s) are:	Remedy:
	2. A problem in the fuel	2. Fuel system <ul style="list-style-type: none"> • Check whether the fuel shut-off valve is OFF (closed) position. • turn the fuel shut-off valve to ON (open) position • Check whether the fuel level is sufficient. • add specified fuel • Check whether the specification of the fuel used is correct. • use the correct fuel specification • Check whether there is water in the sediment bowl. • remove the water and clean the sediment bowl • Check whether the fuel filter is clogged. • replace the fuel filter • Check whether air is present in the fuel system. • bleed air from the fuel system • Check whether there is leak or bent in the fuel line. • contact YOUR LOCAL YANMAR TRACTOR DEALER • Check whether the fuel injection pump is out of timing. • contact YOUR LOCAL YANMAR TRACTOR DEALER • Check whether the fuel nozzles are faulty. • contact YOUR LOCAL YANMAR TRACTOR DEALER
	3. A problem in the cooling	3. Cooling system <ul style="list-style-type: none"> • Check whether the air intake system is clogged. • clean the air intake system
	4. A problem in the lubrication	4. Lubrication system <ul style="list-style-type: none"> • Check whether the engine oil viscosity is high. • replace engine oil with the specified viscosity • Check whether the crankcase ventilation tube is clogged. • clean the crankcase ventilation tube
	5. A problem in the engine mechanical	5. Engine mechanical system <ul style="list-style-type: none"> • Check whether the engine idle speed is too low. • adjust engine idle speed • Check whether the valve clearance is correct. • contact YOUR LOCAL YANMAR TRACTOR DEALER

17. TROUBLESHOOTING

The problem is:	The possible cause(s) are:	Remedy:
The engine runs roughly or stalls frequently	1. A problem in the electrical	1. Electrical system <ul style="list-style-type: none"> • Check whether the battery is fully charged. • charge the battery • Check for loose or corroded the battery terminals and battery cables. • tighten the loose battery terminals • clean the corroded battery terminals and battery cables
	2. A problem in the fuel	2. Fuel system <ul style="list-style-type: none"> • Check whether the fuel level is sufficient. • add specified fuel • Check whether the used fuel specification is correct. • use correct fuel specification • Check whether there is water in the sediment bowl. • remove the water and clean the sediment bowl • Check whether the fuel filter is clogged. • replace the fuel filter • Check whether air is present in the fuel system. • bleed air from the fuel system • Check whether there is leak or bent in the fuel line. • contact YOUR LOCAL YANMAR TRACTOR DEALER • Check whether the fuel injection pump is out of timing. • contact YOUR LOCAL YANMAR TRACTOR DEALER
	3. A problem in the cooling	3. Cooling system <ul style="list-style-type: none"> • Check whether the air intake system is clogged. • clean the air intake system • Check whether coolant temperature is too low. • contact YOUR LOCAL YANMAR TRACTOR DEALER
	4. A problem in the engine mechanical	4. Engine mechanical system <ul style="list-style-type: none"> • Check whether the engine idle speed is too low. • Check whether the valve clearance is correct. • contact YOUR LOCAL YANMAR TRACTOR DEALER

17. TROUBLESHOOTING

The problem is:	The possible cause(s) are:	Remedy:
The engine has no power	1. A problem in the fuel	1. Fuel system <ul style="list-style-type: none"> • Check whether the specification of the fuel used is correct. • use correct fuel specification • Check whether there is water in the sediment bowl. <ul style="list-style-type: none"> • remove the water and clean the sediment bowl • Check whether the fuel filter is clogged. <ul style="list-style-type: none"> • replace the fuel filter • Check whether air is present in the fuel system. <ul style="list-style-type: none"> • bleed air from the fuel system • Check whether the fuel injection pump is out of timing. <ul style="list-style-type: none"> • contact YOUR LOCAL YANMAR TRACTOR DEALER • Check whether the fuel nozzles are faulty. <ul style="list-style-type: none"> • contact YOUR LOCAL YANMAR TRACTOR DEALER
	2. A problem in the cooling	2. Cooling system <ul style="list-style-type: none"> • Check whether the air intake for radiator is clogged. <ul style="list-style-type: none"> • clean the air intake for radiator • Check whether the engine is overheating. <ul style="list-style-type: none"> • contact YOUR LOCAL YANMAR TRACTOR DEALER • Check whether the coolant temperature is too low. <ul style="list-style-type: none"> • contact YOUR LOCAL YANMAR TRACTOR DEALER
	3. A problem in the lubrication	3. Lubrication system <ul style="list-style-type: none"> • Check whether the engine oil viscosity is high. <ul style="list-style-type: none"> • replace engine oil with the specified viscosity • Check for a clogged in the crankcase ventilation tube. <ul style="list-style-type: none"> • contact YOUR LOCAL YANMAR TRACTOR DEALER
	4. A problem in the engine mechanical	4. Engine mechanical system <ul style="list-style-type: none"> • Check whether the valve clearance is correct. <ul style="list-style-type: none"> • contact YOUR LOCAL YANMAR TRACTOR DEALER

17. TROUBLESHOOTING

The problem is:	The possible cause(s) are:	Remedy:
The engine has overheated	1. A problem in the cooling	1. Cooling system <ul style="list-style-type: none"> • Check whether the air intake system is clogged. • clean the air intake system • Check whether the coolant level is low. • add coolant • Check whether the grille, radiator screen or radiator cooling fins are dirty. • clean the radiator grille, radiator screen and radiator fins • Check whether the cooling system needs flushing. • flush the cooling system • Check whether radiator cap and thermostat is/are faulty. • contact YOUR LOCAL YANMAR TRACTOR DEALER
	2. A problem in the engine mechanical	2. Engine mechanical system <ul style="list-style-type: none"> • Check whether the alternator/fan belt is loose or faulty. • adjust or replace the alternator/fan belt
There is a knocking sound coming from the engine	1. A problem in the fuel	1. Fuel system <ul style="list-style-type: none"> • Check whether the specification of the fuel used is correct. • use correct fuel specification • Check whether there is water in the sediment bowl. • remove the water and clean the sediment bowl • Check whether the fuel injection pump is out of timing. • contact YOUR LOCAL YANMAR TRACTOR DEALER • Check whether the fuel nozzles are faulty. • contact YOUR LOCAL YANMAR TRACTOR DEALER
	2. A problem in the cooling	2. Cooling system <ul style="list-style-type: none"> • Check whether the coolant temperature is too low. • contact YOUR LOCAL YANMAR TRACTOR DEALER • Check whether the engine is overheating. • contact YOUR LOCAL YANMAR TRACTOR DEALER
	3. A problem in the lubrication	3. Lubricant system <ul style="list-style-type: none"> • Check whether the engine oil level is low. • add engine oil • Check whether the engine oil viscosity is low. • replace engine oil with the specified viscosity
	4. A problem in the engine mechanical	4. Engine mechanical system <ul style="list-style-type: none"> • Check whether the valve clearance is correct. • contact YOUR LOCAL YANMAR TRACTOR DEALER

17. TROUBLESHOOTING

The problem is:	The possible cause(s) are:	Remedy:
The engine is consuming a lot of fuel	1. A problem in the fuel	1. Fuel system <ul style="list-style-type: none"> • Check whether the specification of the fuel used is correct. • use correct fuel specification • Check whether the fuel system has a leak. <ul style="list-style-type: none"> • contact YOUR LOCAL YANMAR TRACTOR DEALER • Check whether the fuel injection pump is out of timing. <ul style="list-style-type: none"> • contact YOUR LOCAL YANMAR TRACTOR DEALER • Check whether the fuel nozzles are faulty. <ul style="list-style-type: none"> • contact YOUR LOCAL YANMAR TRACTOR DEALER
	2. A problem in the cooling	2. Cooling system <ul style="list-style-type: none"> • Check whether the air intake for radiator is clogged. • clean the air intake for radiator
	3. A problem in the lubrication	3. Lubricant system <ul style="list-style-type: none"> • Check whether the engine oil viscosity is high. • replace engine oil with the specified viscosity
	4. A problem in the engine mechanical	4. Engine mechanical system <ul style="list-style-type: none"> • Check whether the valve clearance is correct. • contact YOUR LOCAL YANMAR TRACTOR DEALER
The oil pressure is low	1. A problem in the lubrication	1. Lubrication system <ul style="list-style-type: none"> • Check whether the engine oil level is low. • add engine oil • Check whether the engine oil viscosity is high. • replace engine oil with the specified viscosity
The engine is consuming a lot of engine oil	1. A problem in the lubrication	1. Lubrication system <ul style="list-style-type: none"> • Check whether there is/are oil leak/s. • contact YOUR LOCAL YANMAR TRACTOR DEALER
	2. A problem in the engine mechanical	2. Engine mechanical system <ul style="list-style-type: none"> • Check whether the valve clearance is correct. • contact YOUR LOCAL YANMAR TRACTOR DEALER

17. TROUBLESHOOTING

The problem is:	The possible cause(s) are:	Remedy:
There is white smoke coming from the engine	1. A problem in the fuel	1. Fuel system <ul style="list-style-type: none"> • Check whether the fuel injection pump is out of timing. • contact YOUR LOCAL YANMAR TRACTOR DEALER
	2. A problem in the cooling	2. Cooling system <ul style="list-style-type: none"> • Check whether the coolant temperature is too low. • contact YOUR LOCAL YANMAR TRACTOR DEALER
	3. A problem in the lubrication	3. Lubrication system <ul style="list-style-type: none"> • Check whether the engine oil level is over filled. • drain the engine oil to the specified level
	4. A problem in the engine mechanical	4. Engine mechanical system <ul style="list-style-type: none"> • Check whether the valve clearance is correct. • contact YOUR LOCAL YANMAR TRACTOR DEALER • Check whether the pistons ring is worn out. • contact YOUR LOCAL YANMAR TRACTOR DEALER • Check whether the compression pressure is too low. • contact YOUR LOCAL YANMAR TRACTOR DEALER • Check whether the cylinder liner are damage. • contact YOUR LOCAL YANMAR TRACTOR DEALER

17. TROUBLESHOOTING

The problem is:	The possible cause(s) are:	Remedy:
There is black smoke coming from the engine	1. A problem in the fuel	1. Fuel system <ul style="list-style-type: none"> • Check whether the specification of the fuel used is correct. • use correct fuel specification • Check whether the air filter is clogged. <ul style="list-style-type: none"> • replace the air filter • Check whether there is water in the sediment bowl. <ul style="list-style-type: none"> • remove the water and clean the sediment bowl • Check whether the fuel nozzles are faulty. <ul style="list-style-type: none"> • contact YOUR LOCAL YANMAR TRACTOR DEALER • Check whether the fuel injection pump is out of timing. <ul style="list-style-type: none"> • contact YOUR LOCAL YANMAR TRACTOR DEALER
	2. A problem in the cooling	2. Cooling system <ul style="list-style-type: none"> • Check whether the air intake system is clogged. • clean the air intake system
	3. A problem in the lubrication	3. Lubrication system <ul style="list-style-type: none"> • Check whether the engine oil level is correct. • drain the engine oil to the specified level
	4. A problem in the engine mechanical	4. Engine mechanical system <ul style="list-style-type: none"> • Check whether the valve clearance is correct. • contact YOUR LOCAL YANMAR TRACTOR DEALER

2. Electrical System

The problem is:	The possible cause(s) are:	Remedy:
The alternator/battery charging light remains illuminated even though the engine is running	1. A problem in the charging system	1. Charging systems <ul style="list-style-type: none"> • Check whether the alternator/fan belt is loose or faulty. <ul style="list-style-type: none"> • adjust or replace the alternator/fan belt • Check whether the fuse/s is/are blown. <ul style="list-style-type: none"> • replace the blown fuses • Check whether the alternator is faulty. <ul style="list-style-type: none"> • contact YOUR LOCAL YANMAR TRACTOR DEALER
	2. A problem in the battery	2. Battery <ul style="list-style-type: none"> • Check whether the battery is faulty. • replace the battery
	3. A problem in the engine mechanical	3. Engine mechanical system <ul style="list-style-type: none"> • Check whether the engine idle speed is too low. • adjust engine idle speed

17. TROUBLESHOOTING

The problem is:	The possible cause(s) are:	Remedy:																								
The starter does not turn	1. A problem in the starter	1. Starter <ul style="list-style-type: none"> • Check whether the fuse/s is/are blown. • replace the blown fuse/s • Check whether the starter key switch or the starter is/are faulty. • contact YOUR LOCAL YANMAR TRACTOR DEALER 																								
	2. A problem in the battery	2. Battery <ul style="list-style-type: none"> • Check for loose or corroded the battery terminals and battery cables. • tighten the loose battery terminals • clean the corroded battery terminals and battery cables • Check whether the battery is faulty. • replace the battery 																								
	3. A problem in the electrical	3. Electrical system <ul style="list-style-type: none"> • Check whether the interface combination functions correctly. <div style="text-align: center; border: 1px solid black; padding: 5px; margin: 10px 0;"> <table style="border-collapse: collapse; width: 100%;"> <tr> <td style="border: none;">SWITCH</td> <td style="border: none;"></td> <td style="border: none;"></td> <td style="border: none;"></td> <td style="border: none;"></td> </tr> <tr> <td style="border: none;"></td> <td style="border: none;">SEAT-ON</td> <td style="border: none;">FORWARD/REVERSE-N</td> <td style="border: none;">PTO-N</td> <td style="border: none;">PARKING BRAKE</td> </tr> <tr> <td style="border: none;">ENGINE</td> <td style="border: none;"></td> <td style="border: none;"></td> <td style="border: none;"></td> <td style="border: none;"></td> </tr> <tr> <td style="border: none;">START 1</td> <td style="text-align: center;">○</td> <td style="text-align: center;">○</td> <td style="text-align: center;">○</td> <td style="text-align: center;">○</td> </tr> <tr> <td style="border: none;">START 2</td> <td style="text-align: center;">○</td> <td style="text-align: center;">○</td> <td style="text-align: center;">○</td> <td style="text-align: center;">○</td> </tr> </table> </div> <ul style="list-style-type: none"> • contact YOUR LOCAL YANMAR TRACTOR DEALER 	SWITCH						SEAT-ON	FORWARD/REVERSE-N	PTO-N	PARKING BRAKE	ENGINE					START 1	○	○	○	○	START 2	○	○	○
SWITCH																										
	SEAT-ON	FORWARD/REVERSE-N	PTO-N	PARKING BRAKE																						
ENGINE																										
START 1	○	○	○	○																						
START 2	○	○	○	○																						
The starter turns too slowly	1. A problem in the starter	1. Starter <ul style="list-style-type: none"> • Check whether the starter is faulty. • contact YOUR LOCAL YANMAR TRACTOR DEALER 																								
	2. A problem in the battery	2. Battery <ul style="list-style-type: none"> • Check for loose or corroded the battery terminals and battery cables. • tighten the loose battery terminals • clean the corroded battery terminals and battery cables • Check whether the battery voltage is not lower than 12V. • replace the battery • Check whether the battery is faulty. • replace the battery 																								
	3. A problem in the lubrication	3. Lubrication system <ul style="list-style-type: none"> • Check whether the engine oil viscosity is high. • replace engine oil with the specified viscosity 																								

3. Brakes

The problem is:	The possible cause(s) are:	Remedy:
The rear brakes are not working correctly	1. A problem in the brake	1. Brake system <ul style="list-style-type: none"> • Check whether the brakes are adjusted correctly. • adjust the brakes correctly • Check whether the brake linkage is worn out or damaged. • contact YOUR LOCAL YANMAR TRACTOR DEALER • Check whether the brake disk is worn out or damaged. • contact YOUR LOCAL YANMAR TRACTOR DEALER

4. Steering

The problem is:	The possible cause(s) are:	Remedy:
The steering is not working	1. A problem in the steering	1. Steering <ul style="list-style-type: none"> • Check whether the transmission hydraulic oil level is low. • add transmission hydraulic oil • Check whether the wheel spindles are damaged. • contact YOUR LOCAL YANMAR TRACTOR DEALER
	2. A problem in the steering cylinder	2. Steering cylinder <ul style="list-style-type: none"> • Check whether the steering linkage requires lubrication. • lubricate the steering linkage • Check for excessive play in the steering. • contact YOUR LOCAL YANMAR TRACTOR DEALER

5. Body and Machinery

The problem is:	The possible cause(s) are:	Remedy:
There is excessive vibration	1. A problem in the engine	1. Engine <ul style="list-style-type: none"> • Check whether the idle speed is too slow. • adjust the idle speed
	2. A problem in the transmission	2. Transmission <ul style="list-style-type: none"> • Check whether the drive shaft is worn out. • contact YOUR LOCAL YANMAR TRACTOR DEALER
The engine is running, but the tractor does not move	1. A problem in the transmission	1. Transmission <ul style="list-style-type: none"> • Check whether the transmission system worn out. • contact YOUR LOCAL YANMAR TRACTOR DEALER
	2. A problem in the brake	2. Brake system <ul style="list-style-type: none"> • Check whether the brakes are adjusted correctly. • adjust the brakes correctly
The 3-point hitch does not rise	1. A problem in the transmission hydraulic oil	1. Transmission hydraulic oil <ul style="list-style-type: none"> • Check whether the transmission hydraulic oil level is too low. • add transmission hydraulic oil
	2. A problem in the transmission hydraulic oil flow	2. Transmission hydraulic oil flow <ul style="list-style-type: none"> • Check whether the transmission hydraulic flow control/stop knob has been closed (OFF). • open the hydraulic flow control/stop knob • Check whether an excessive load is being placed on the 3-point hitch. • reduce the 3-point hitch load • Check whether the transmission hydraulic oil filter is clogged. • replace the transmission hydraulic oil filter
The 3-point hitch lowers too slowly or does not lower at all	1. A problem in the hydraulic flow control/stop valve	1. Hydraulic flow control/stop valve <ul style="list-style-type: none"> • Check whether the hydraulic flow control/stop knob has been closed (OFF). • open the hydraulic flow control/stop knob on the specified rate • Check whether the rate of drop is set too slow. • set the hydraulic flow control/stop knob to the specified rate
	2. A problem in the transmission hydraulic oil	2. Transmission hydraulic oil <ul style="list-style-type: none"> • Check whether the transmission hydraulic oil level is too low. • add transmission hydraulic oil
The 3-point hitch lowers too quickly	1. A problem in the hydraulic flow control/stop valve	1. Hydraulic flow control/stop valve <ul style="list-style-type: none"> • Check whether the rate of drop is set too fast. • adjust hydraulic flow control/stop knob to specified rate
	2. A problem on loads	2. Loads <ul style="list-style-type: none"> • Check whether an excessive load is being placed on the hitch. • reduce excessive load

18. INDEX

2WD/4WD lever	5-10, 8-7	Parking Brake Lock Lever	5-8
3-Point Hitch.....	10-1	Parking Brake Indicator Light.....	5-12
3-Point Hitch Control Lever	5-7, 8-8, 10-2	Periodic Service	14-1
3-Point Hitch Control System	11-1	Pictographs	2
Alternator/Fan Belt	13-5, 14-14, 14-20	Position Stop Knob	5-7, 10-2, 11-2
Alternator/Battery Charging Light.....	5-13	Power Take Off (PTO) Indicator Light	5-12
Battery.....	15-1	Power Take Off (PTO) Switch	5-4
Brake.....	8-13, 14-30	Power Take Off (PTO) Select Lever.....	5-8
Brake Pedal Connector Lock	5-9	Power Take Off (PTO) Shaft.....	5-1
Brake Pedals.....	5-9, 8-13	Power Take Off (PTO) Shaft Cap.....	9-4
Bulb	13-5, 15-5	Power Take Off (PTO) System.....	9-1
Differential Lock	8-14	Push or Tow the Tractor	8-16
Differential Lock Pedal	5-10	Radiator Cooling Fins	14-9
Drawbar.....	10-6	Radiator Cooling Screen.....	14-9
Engine Coolant.....	14-33	Radiator Hoses and Clamps.....	14-8
Engine Coolant Temperature Warning Light.....	5-12	Range Gear Lever	5-8, 8-7
Engine Runs Out of Fuel.....	7-9	Rear Tires	5-1
Fender.....	5-1	Replacement Parts	13-5
Forward and Reverse Drive Pedal.....	5-6, 8-9	Retractable Seatbelt	5-7, 7-2, 14-6
Front Tires.....	5-1	Roll-Over Protective Structure (ROPS) ..	5-1, 8-3, 14-6
Fuel	13-4, 14-7	Safety Chain	10-7
Fuel Filter	13-5, 14-23, 14-29	Safety Interlock System.....	14-11
Fuel Gauge	5-12	Safety Precautions.....	1-1
Fuel Filler Cap.....	5-1	Shut OFF the Engine	7-7
Fuel Shut-Off Valve.....	7-2	Slow Moving Vehicle (SMV) Emblem	5-1, 8-15
Fuel Tank	14-7	Specifications.....	3-1
Fuel/Water Separator.....	14-21, 14-23	Stabilizer	10-5
Fuses	15-4	Stalled Engine	7-8
Grease Up.....	14-17	Starter Key Switch	5-5, 7-5
Hazard Lights	5-5, 14-6	Starting Cold Weather	7-7
Hazard Lights Button Switch	5-5	Tachometer.....	5-12
Hazard Lights/Left Turn Signal Indicator Light...	5-12	Tail Lights	5-1, 5-5
Headlights	5-5, 14-6, 15-7	Throttle Control Lever	5-5, 8-9, 14-33
Hood	14-2	Tire Air Pressure.....	14-5
Hour Meter	5-12	Tires.....	12-1
Hydraulic Flow Control/Stop Knob ...	5-10, 10-2, 11-2	Top Link.....	5-1, 10-3
Idle the Engine	7-6	Top Link Hook.....	5-1
Implement Capacities.....	4-1	Traveling Speeds.....	3-2
Implement Hydraulic Hoses	11-5	Tire Tread Width	12-3
Lower Links	10-3	Troubleshooting	17-1
Lubricants.....	13-4	Turn Signal/Hazard Lights	5-1
Maintenance.....	13-1	Turn Signals.....	8-5
Mid-/Rear Power Take Off (PTO) Select Lever....	5-8	Warm Up the Engine in Cold Weather.....	7-7
Open/Close the Hood.....	14-2	Warm Up Transmission Hydraulic Oil in a Cold Weather Situation.....	8-6
Operate the Implement Control Valve.....	11-3	Weight.....	12-4
Operator Station Controls	5-3	Wheel.....	12-2
Operator Seat.....	7-2	Wheel Bolt Tightening Torque	12-2, 14-10
Operator Seat Forward and Backward Lever	5-9, 7-2		
Parking Brake.....	7-3, 8-13		

NOTE

NOTE

NOTE

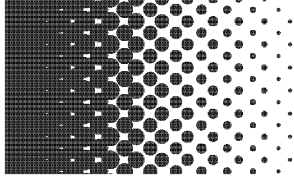

COMPACT TRACTOR

YANMAR



YANMAR AMERICA CORPORATION

101 International Pkwy
Adairsville, GA 30103
<http://www.yanmar.com>

ENGLISH