

Kawasaki

Engines

FD851D

4-Stroke Air-Cooled V-Twin Gasoline Engine

OWNER'S MANUAL

Part No. 99920-2279-01

SAFETY AWARENESS

Whenever you see the symbols shown below, heed their instructions! Always follow safe operating and maintenance practices.

DANGER

DANGER indicates a hazardous situation which, if not avoided, will result in death or serious injury.

WARNING

WARNING indicates a hazardous situation which, if not avoided, could result in death or serious injury.

CAUTION

CAUTION indicates a hazardous situation which, if not avoided, could result in minor or moderate injury.

NOTICE

NOTICE is used to address practices not related to personal injury.

NOTE

○ *This note symbol indicates points of particular interest for more efficient and convenient operation.*

READ THE OPERATING INSTRUCTIONS OF THE EQUIPMENT THIS ENGINE POWERS.

READ THIS FIRST

For your safety, read this Owner's Manual and understand it thoroughly before operating this ENGINE.

DANGER

Exhaust gas contains carbon monoxide, a colorless, odorless poisonous gas. Inhaling carbon monoxide can cause serious brain injury or death.

DO NOT run the engine in enclosed areas. Operate only in a well-ventilated area. Gasoline is extremely flammable and can be explosive under certain conditions, creating the potential for serious burns. When refueling, servicing fuel system, draining gasoline and/or adjusting the carburetor: Stop engine and allow it to cool before refueling.

DO NOT smoke.

Make sure the area is well-ventilated and free from any source of flame or sparks, including the pilot light of any appliance.

DO NOT fill the tank so the fuel level rises into the filler neck or level surface of level gauge. If the tank is overfilled, heat may cause the fuel to expand and overflow through the vents in the tank cap. Wipe off any spilled gasoline immediately.

Engines can become extremely hot during normal operation.

To prevent fire hazard:

Keep the engine at least 1 m (3.3 ft) away from buildings, obstructions and other flammable objects.

DO NOT place flammable objects close to the engine.

DO NOT expose combustible materials to the engine exhaust.

DO NOT use the engine on any forest covered, brush covered or grass covered unimproved land unless spark arrester is installed on the muffler.

To avoid getting an electric shock, **DO NOT** touch spark plugs, plug caps or spark plug leads during engine running.

To avoid a serious burn, **DO NOT** touch a hot engine or muffler. The engine becomes hot during operation. Before you service or remove parts, stop engine and allow the engine to cool.

DO NOT place hands or feet near moving or rotating parts. Place a protective cover over pulley, V belt or coupling.

DO NOT run engine at excessive speeds. This may result in injury.

Always remove the spark plug caps from spark plugs when servicing the engine to prevent accidental starting.

Read warning labels which are on the engine and understand them. If any label is missing, damaged, or worn get a replacement from your Kawasaki dealer and install it in the correct position.

EMISSION CONTROL INFORMATION

Fuel Information

THIS ENGINE IS CERTIFIED TO OPERATE ON UNLEADED REGULAR GRADE GASOLINE ONLY. A minimum of 87 octane of the antiknock index is recommended. The antiknock index is posted on service station pumps in the U.S.A.

Emission Control Information

To protect the environment in which we all live, Kawasaki has incorporated an exhaust emission control system in compliance with applicable regulations of the United States Environmental Protection Agency and the California Air Resources Board. Also, depending on when your engine was produced, it may have an assigned emissions durability period. * See below for the engine emissions durability period that may apply to your engine.

Exhaust Emission Control System

The exhaust emission control system applied to this engine consists of a fuel system and an ignition system having optimum ignition timing characteristics. The fuel system has been calibrated to provide lean air/fuel mixture characteristics and optimum fuel economy with a suitable air cleaner and exhaust system.

A sealed-type crankcase emission control system is also used to eliminate blow-by gasses. The blow-by gasses are led to a breather chamber through the crankcase and from there to the air cleaner.

Engine Emissions Compliance Period

California

Engines Greater Than or Equal To 225 cc

Model Year – 2010 and later

Durability Period – 1000 hours

All Other States

Engines Greater Than or Equal To 225 cc

Model Year – 2010 and later

Durability Period – 1,000 hours (Category A)

If your engine has an assigned emissions durability period it will be located on the certification label attached to the engine (IMPORTANT ENGINE INFORMATION).

High Altitude Performance Adjustment Information

To improve the EMISSIONS CONTROL PERFORMANCE of engines operated above 1,000 meters (3,300 feet) , Kawasaki recommends the following Environmental Protection Agency (EPA) and the California Air Resources Board (CARB) approved modifications.

However, the models with DFI (Digital Fuel Injection system) does not require high altitude performance adjustment.

NOTE

○ *When properly performed, these specified modifications only are not considered to be emissions system "tampering" and engine performance is generally unchanged as a result.*

Maintenance and Warranty

Proper maintenance is necessary to ensure that your engine will continue to have low emission levels. This Owner's Manual contains those maintenance recommendations for your engine. Those items identified by the Periodic Maintenance Chart are necessary to ensure compliance with the applicable standards.

As the owner of the engine, you have the responsibility to make sure that the recommended maintenance is carried out according to the instructions in this Owner's Manual at your own expense.

The Kawasaki Limited Emission Control System Warranty requires that you return your engine to an authorized Kawasaki dealer for remedy under warranty. Please read the warranty carefully, and keep it valid by complying with the owner's obligations it contains.

Tampering with Emission Control System Prohibited

Federal law and California State law prohibit the following acts or the causing thereof: (1) the removal or rendering inoperative by any person other than for purposes of maintenance, repair, or replacement, of any device or element of design incorporated into any new engine for the purposes of emission control prior to its sale or delivery to the ultimate purchaser or while it is in use, or (2) the use of the engine after such device or element of design has been removed or rendered inoperative by any person.

Among those acts presumed to constitute tampering are the acts listed below:

Do not tamper with the original emission related parts:

- Carburetor or DFI system, and their internal parts
- Spark Plugs
- Magneto or electronic ignition system
- Fuel filter element
- Air cleaner elements
- Crankcase
- Cylinder heads
- Breather chamber and internal parts
- Intake pipe and tube
- Fuel hose
- Carbon canister
- Muffler or any internal portion of the muffler

FOREWORD

This Owner's Manual provided to aid you in the safe and reliable operation of your Engine. **READ AND UNDERSTAND IT THOROUGHLY BEFORE OPERATING YOUR ENGINE.**

READ THE OPERATING INSTRUCTIONS OF THE EQUIPMENT THIS ENGINE POWERS.

To ensure a long, trouble-free life for your Engine, give it proper care and maintenance in accordance with this Owner's Manual.

All rights reserved. No part of this publication may be reproduced, stored in a retrieval system, or transmitted in any form or by any means, electronic mechanical photocopying, recording or otherwise, without the prior written permission of Kawasaki Heavy Industries, Ltd., Motorcycle & Engine Company. Although every possible care has been taken to make this manual as complete and accurate as possible, Kawasaki cannot guarantee against errors and omissions. Due to improvements in design and performance during production, procedures and specifications are subject to change without prior notice. Illustrations are provided for general reference purposes, and may differ from actual product aspects and components.

TABLE OF CONTENTS

GENERAL INFORMATION	9	Throttle Cable Installation, Adjustment.....	22
Location of Safety Related Labels.....	9	Engine Speed Adjustment.....	23
Parts Location	10	MAINTENANCE	24
Tune-up Specifications	11	Periodic Maintenance Chart	24
Coolant and Engine Oil Capacity	11	Oil Level Check	26
FUEL AND OIL RECOMMENDATIONS	12	Oil Change	26
Fuel	12	Oil Filter Change	27
Engine Oil.....	13	Cooling System Inspection.....	28
PREPARATION	14	Air Cleaner Service	29
Fuel	14	Primary Element.....	29
Engine Oil.....	14	Secondary Element	29
Coolant.....	16	Cap (Dust Ejector Valve).....	29
STARTING	17	Fuel Filter and Fuel Pump Service	31
Start Engine.....	17	Spark Plug Service.....	32
OPERATING	19	STORAGE	33
Warming Up.....	19	Fuel System Draining	33
Engine Inclination	20	TROUBLESHOOTING GUIDE	34
STOPPING	21	ENVIRONMENTAL PROTECTION	36
Ordinary Stop	21	SPECIFICATIONS	37
Emergency Stop.....	21	WIRING DIAGRAM	38
ADJUSTMENT	22	Wiring Diagram.....	38

GENERAL INFORMATION

Location of Safety Related Labels

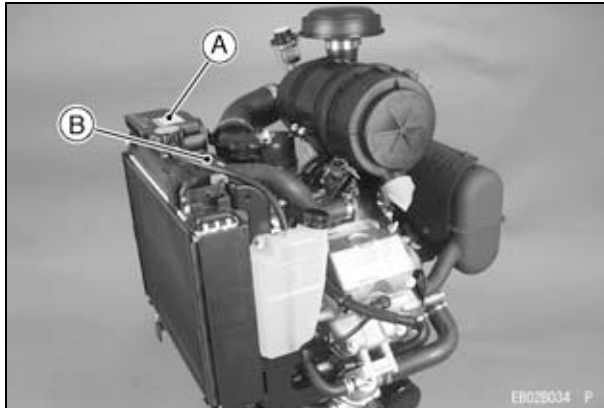

A. Warning

B. Engine Maintenance

The engine serial number is your only means of identifying your particular engine from others of the same model type.

This engine serial number is needed by your dealer when ordering parts.

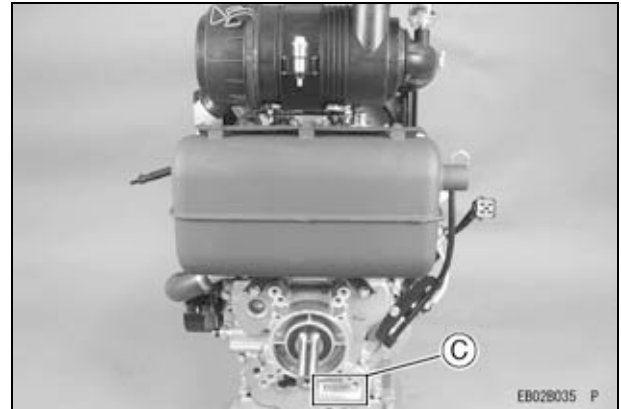

C. Engine Serial Number

10 GENERAL INFORMATION

Parts Location

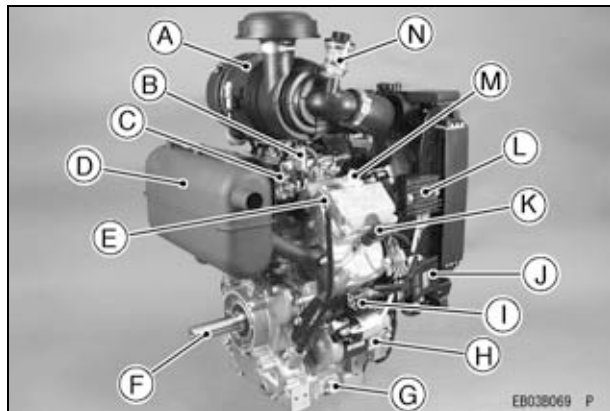

- A. Air Cleaner
- B. Fuel Regulator
- C. Control Panel
- D. Muffler
- E. Oil Gauge
- F. P.T.O. Shaft
- G. Oil Drain Plug
- H. Electric Starter
- I. Connector
- J. ECU
- K. Spark Plug
- L. Voltage Regulator
- M. Oil Filler
- N. Air Filter Gauge

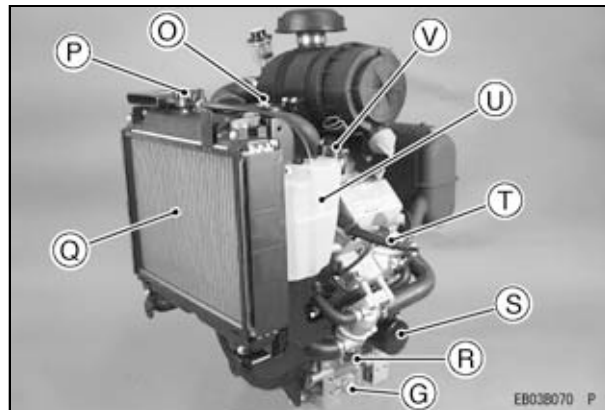

- O. Throttle Body
- P. Radiator Cap
- Q. Radiator
- R. Coolant Drain Plug
- S. Oil Filter
- T. Fuel Tube
- U. Coolant Overflow Reservoir
- V. Coolant Overflow Reservoir Cap

Tune-up Specifications

ITEM	Specifications
Ignition Timing	Unadjustable
Spark Plugs: Gap	NGK BPR4ES Gap: 0.7 ~ 0.8 mm
Low Idle Speed	1 550 r/min (rpm)
High Idle Speed	3 600 r/min (rpm)
Valve Clearance	In 0.15 mm (0.006 in) Ex 0.15 mm (0.006 in)
Other Specifications	No other adjustment needed

NOTE

- High and low idle speeds may vary depending on the equipment on which the engine is used. Refer to the equipment specification.

Coolant and Engine Oil Capacity

Coolant Capacity

FD851D	2.7 L (2.9 US.qt)
--------	----------------------

Type: Permanent Type of Antifreeze.
Green Colored

Mixed Ratio: Water 50%: Antifreeze 50% (1:1)

Freezing Point: -35°C (-31°F)

Engine Oil Capacity

FD851D	1.8 L (1.9 US·qt) [when oil filter is not removed]
	2.0 L (2.1 US·qt) [when oil filter is removed]

FUEL AND OIL RECOMMENDATIONS

Fuel

Use only clean, fresh, unleaded regular grade gasoline.

NOTICE

Do not mix oil with gasoline.

Octane Rating

The octane rating of a gasoline is a measure of its resistance to “knocking”. Using a minimum of 87 octane by the antiknock index is recommended. The antiknock index is posted on service station pumps in the U.S.A.

NOTE

○ If “knocking or pinking” occurs, use a different brand of gasoline or higher octane rating.

Oxygenated Fuel

Oxygenates (either ethanol or MTBE) are added to the gasoline. If you use the oxygenated fuel be sure it is unleaded and meets the minimum octane rating requirement.

The following are the EPA approved percentages of fuel oxygenates.

ETHANOL: (Ethyl or Grain Alcohol)

You may use gasoline containing up to 10% ethanol by volume.

MTBE: (Methyl Tertiary Butyl Ether)

You may use gasoline containing up to 15% MTBE by volume.

METHANOL: (Methyl or Wood Alcohol)

You may use gasoline containing up to 5% methanol by volume, as long as it also contains cosolvents and corrosion inhibitors to protect the fuel system. Gasoline containing more than 5% methanol by volume may cause starting and/or performance problems. It may also damage metal, rubber, and plastic parts of your fuel system.

Engine Oil

The following engine oils are recommended.
 API Service Classification : SF, SG, SH or SJ.

Oil Viscosity

Choose the viscosity according to the temperature as follows:

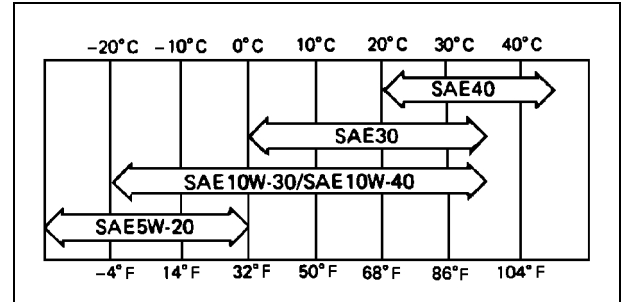

NOTE

- Using multi grade oils (5W-20, 10W-30, and 10W-40) will increase oil consumption. Check oil level more frequently when using them.

PREPARATION

Fuel

WARNING

Gasoline is extremely flammable and can be explosive under certain conditions, creating the potential for serious burns. When refueling, servicing fuel system, draining gasoline and/or adjusting the carburetor: Stop engine and allow it to cool before refueling. DO NOT smoke. Make sure the area is well ventilated and free from any source of flame or sparks, including the pilot light of any appliance. DO NOT fill the tank so the fuel level rises into the filler neck or level surface of level gauge. If the tank is overfilled, heat may cause the fuel to expand and overflow through the vents in the tank cap. Wipe off any spilled gasoline immediately.

Engine Oil

Check the engine oil daily before starting the engine otherwise shortage of the engine oil may cause serious damage to the engine such as seizure.

- Place the engine on level surface. Clean area around the oil gauge before removing it.
- Remove the oil gauge (A) and wipe it with clean cloth.
- Insert the oil gauge into tube (B) and let its plug firmly fit into the tube, then remove the oil gauge and check the oil level.
- The oil level should be between the “H” and “L” marks on the oil gauge.
- ★ If the oil level is near or below the “L” mark, remove the oil filler cap (C) and pour the engine oil slowly to bring oil level to the “H” mark.
- Insert firmly the oil gauge into the tube and tighten the oil filler cap.

Engine Oil Capacity

FD851D	1.8 L (1.9 US-qt) [when oil filter is not removed]
	2.0 L (2.1 US-qt) [when oil filter is removed]

- ★ If the oil level is too high, remove the excess oil by loosening the drain plug (D).

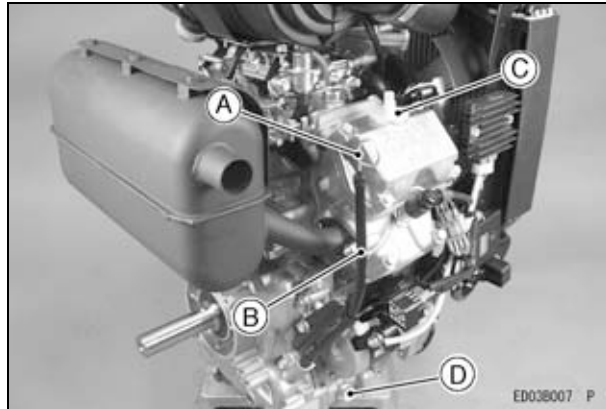

NOTICE

Do not fill above the “H” mark. Excess oil will cause a smoking condition, and may cause the engine to overheat.

NOTICE

The engine is shipped without fuel, engine oil and coolant.

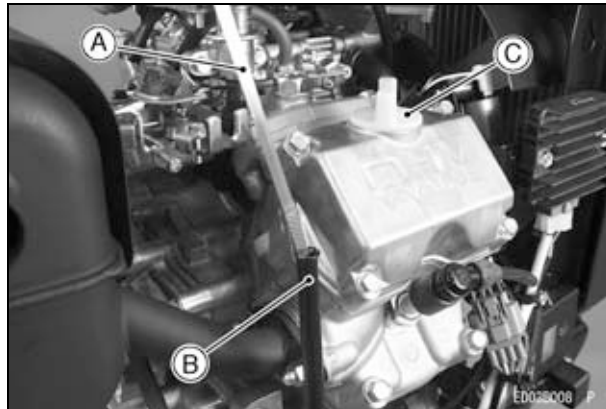

- A. Oil Gauge
- B. Tube
- C. Oil Filler Cap
- D. Oil Drain Plug

16 PREPARATION

Coolant

NOTE

- *Have the first original permanent type of antifreeze replenished by your authorized KAWASAKI Dealer.*

Check Coolant daily before starting the engine.

- Be sure the engine is level.
- Check the coolant level only at the overflow reservoir (A). The cooling system is a closed type. Never open the radiator cap. Doing so may induce air into the cooling system and may cause overheating.
- The coolant level should be between the "H"(H) and "L"(L) marks.

NOTE

- *Check the level when the engine is cold (room or atmospheric temperature).*
- If the amount of coolant is insufficient, remove the cap (B) from the reservoir and add coolant to the "H" mark. Install the cap.

Recommended Coolant Solution

Coolant Mixture Ratio:

Water 50% : Antifreeze 50%(1 : 1)

Recommended Antifreeze:

Permanent type antifreeze (ethylene glycol plus corrosion and rust inhibitor chemicals for cast-iron engines and aluminum radiators)

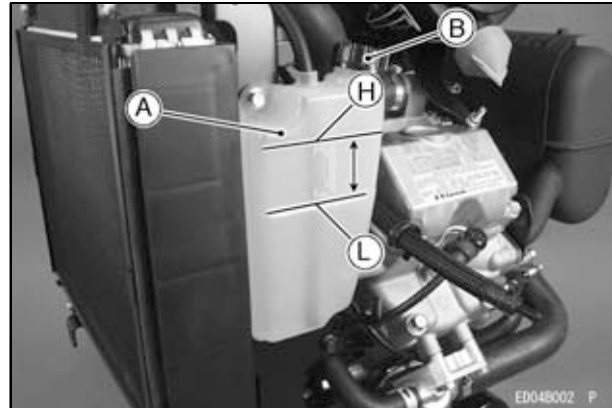

STARTING

Start Engine

DANGER

Exhaust gas contains carbon monoxide, a colorless, odorless poisonous gas. Inhaling carbon monoxide can cause serious brain injury or death. **DO NOT** run the engine in enclosed areas. Operate only in a well-ventilated area.

WARNING

Engine exhaust may ignite combustible materials and cause a fire. Keep the area around the exhaust outlet clear. Locate the unit so that the exhaust outlet points toward an open area and is located at least one meter (3.3 feet) from any obstructions.

NOTE

- *Be aware of the following in order to start the engine easily in cold weather.*
- *Use proper oil for temperature expected (See "FUEL AND OIL RECOMMENDATIONS" chapter).*

- *Use fresh gasoline.*
- *Protect the engine or the equipment from direct exposure to weather when not in operation.*

NOTE

- *Follow the operating instructions of the equipment this engine powers.*
- Before starting the engine, insure all possible external loads are disconnected.
- Open the fuel valve (A) on the equipment.
- Move throttle lever on the equipment to half throttle position.
- Put the switch key into the engine switch.
- Turn the switch key to the ON position and then move the switch key to the START position. Usually engine will start within 3 seconds.

NOTICE

Do not run the electric starter continuously for more than 5 seconds, otherwise the battery may discharge quickly. If the engine does not start right away, wait 15 seconds and try again.

18 STARTING

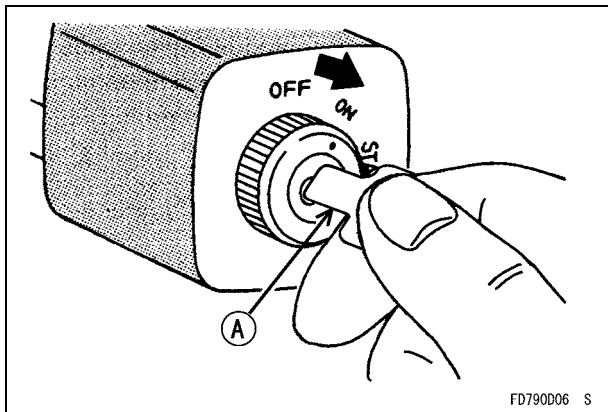
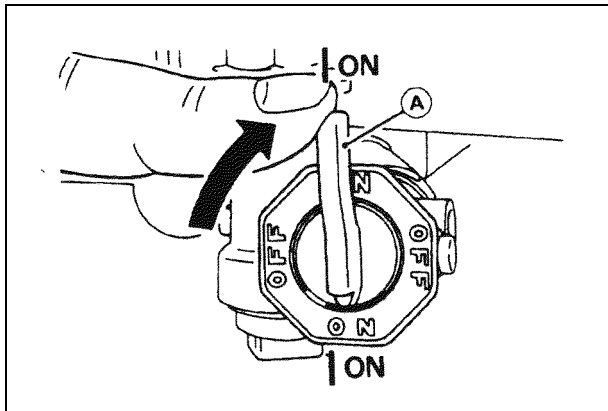

FD790D06 S

NOTICE

Whenever you start engine, make sure warning light is not illuminated. If warning light comes on, stop engine immediately and check oil level (If equipped the warning light on the dash).

NOTICE

Make sure that the self-diagnosis light on the dash comes on, when the switch key is turned to "ON" position, and comes off soon after ensuring that its circuit functions properly. If this light comes on, stop engine immediately and contact your Kawasaki dealer. (If equipped the self-diagnosis light on the dash.)

OPERATING

Warming Up

After the engine starts, move the throttle lever (A) on the equipment to halfway between “FAST” and “SLOW”.

To warm up the engine, run it for 3 to 5 minutes with the throttle lever in the same position (halfway) before putting the equipment under load. Then, move the throttle lever to its “FAST” position.

NOTICE

Allow engine to warm up sufficiently (3 to 5 minutes at idle) before applying a load. This will allow oil to reach all engine parts, and allow piston clearance to reach design specifications.

NOTICE

While warming up the engine, make sure the warning lights (oil pressure, charging monitor, and coolant temperature and/or self-diagnosis light) on the dash are not on. These lights must not be illuminated during engine operation.

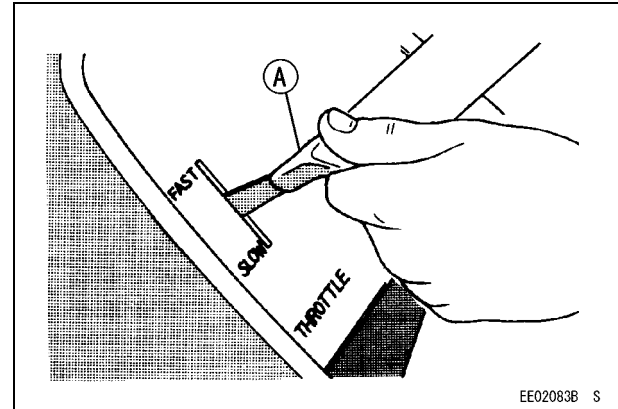

A. Throttle Lever

20 OPERATING

Engine Inclination

This engine will operate continuously at angles up to 25° in any direction.

Refer to the operating instructions of the equipment this engine powers. Because of equipment design or application, there may be more stringent restrictions regarding the angle of operation.

NOTICE

Do not operate this engine continuously at angles exceeding 25° in any direction. Engine damage could result from insufficient lubrication.

STOPPING

Ordinary Stop

- Move throttle lever (A) to SLOW position.
- Lower the engine speed to an idle. Keep running at idle for about one minute.

NOTICE

Engine damage can occur from run-on or after-burning if engine is stopped suddenly from high speed loaded operation. Reduce engine speed to idle for one minute before shutting engine off.

- Turn the engine switch or the switch key to “OFF” position.
For Control Panel Switch Type, move the throttle lever on the equipment against its low speed end to turn ignition off.

Emergency Stop

- Immediately turn the engine switch or the switch key to “OFF” position.
- Close the fuel valve on the equipment.
For Control Panel Switch Type, move the throttle lever against its low speed end. Moving the lever against its low speed end turns ignition off.

⚠ WARNING

Leaving the equipment with the key hanging in the ignition can allow operation by someone who does not know how to operate it. It may cause serious accident with injury. Always remove the key from unattended equipment.

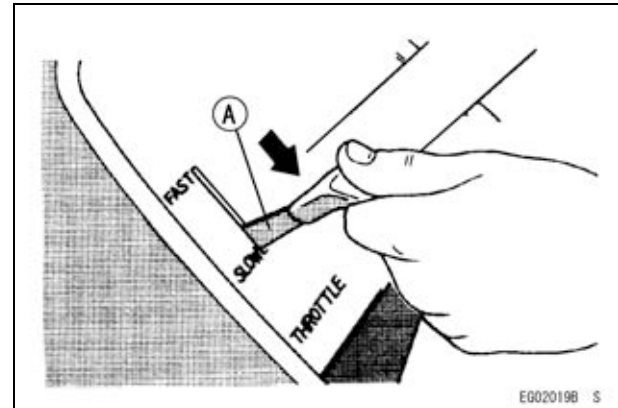

A. Throttle Lever

ADJUSTMENT

Throttle Cable Installation, Adjustment

- Link the throttle cable (A) to the speed control lever (B) and loosely clamp the throttle cable outer housing (C) with the cable clamp bolt (D).
- Move the throttle lever on the equipment to “FAST” position.
- Pull up the outer housing (C) of the throttle cable until the inner wire (A) has almost no slack, and tighten the cable clamp bolt (D).
- Move the throttle lever to “SLOW” position. Make sure that the throttle shaft Assembly (E) is moved smoothly.

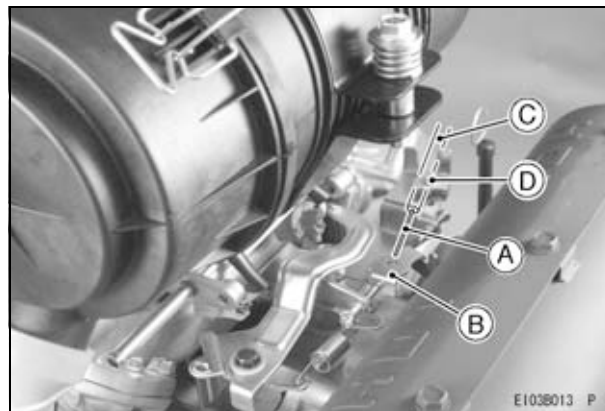

- A. Throttle Cable**
- B. Speed Control Lever**
- C. Throttle Cable Outer Housing**
- D. Cable Clamp Bolt**



E. Throttle Shaft Assembly

Engine Speed Adjustment

NOTE

- *Do not tamper with the governor setting, the carburetor setting and/or DFI system to increase the engine speed. Every carburetor and/or DFI system is adjusted at the factory and a cap or stop plate is installed on each mixture screw.*
- *If adjustment is needed, it must be performed by your authorized Kawasaki dealer.*

MAINTENANCE

Periodic Maintenance Chart

Maintenance, replacement, or repair of the emission control devices and systems may be performed by any nonroad engine repair establishment or individual.

WARNING

Prevent accidental starting during engine service by removing the spark plug caps.

NOTE

○ The service intervals indicated are to be used as a guide. Service should be performed more frequently as determined by operating conditions.

MAINTENANCE	INTERVAL							
	Daily	First 8 hr.	Every 25 hr.	Every 50 hr.	Every 100 hr.	Every 200 hr.	Every 300 hr.	Every 400 hr.
Check and add engine oil	●							
Check for loose or lost bolts, nuts and screws	●							
Check for fuel and oil leakage	●							
Check battery electrolyte level	●							
Check and clean radiator screen	●							
Tighten bolts, nuts and screws			●					

MAINTENANCE	INTERVAL									
	Daily	First 8 hr.	Every 25 hr.	Every 50 hr.	Every 100 hr.	Every 200 hr.	Every 250 hr.	Every 300 hr.	Every 400 hr.	Every 500 hr.
Change engine oil		•			•					
Clean and regap spark plugs					•					
Change oil filter						•				
★ Replace air cleaner primary element							•			
★ Check air cleaner secondary element							•			
★ Replace air cleaner secondary element										•
K Clean combustion chambers								•		
K Check and adjust valve clearance								•		
K Clean and lap valve seating surface								•		
K Inspect radiator and hoses						•				
K Check fan belt conditions and tension						•				
K Change coolant									•	

★: Service more frequently under dusty conditions.

K: Have an authorized Kawasaki dealer perform these service.

Oil Level Check

Check oil level daily and before each time of operation. Be sure oil level is maintained. (See “PREPARATION” chapter.)

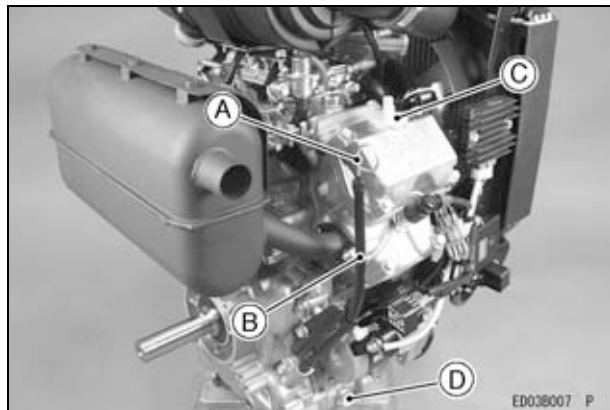

- A. Oil Gauge
- B. Tube
- C. Oil Filler Cap
- D. Oil Drain Plug

Oil Change

Change oil after first 8 hours of operation. Thereafter change oil every 100 hours.

- Run the engine to warm oil.
- Be sure the engine (equipment) is level.
- Stop the engine.
- Remove the oil drain plug and drain the oil into suitable container while engine is warm.

⚠ WARNING

Hot engine oil can cause severe burns. Allow engine temperature to drop from hot to warm level before draining and handling oil.

- Install the oil drain plug.
- Remove oil filler cap and refill with fresh oil (See “FUEL AND OIL RECOMMENDATIONS” chapter.)
- Check the oil level (see “PREPARATION” chapter for oil level check).

⚠ WARNING

Engine oil is a toxic substance. Dispose of used oil properly. Contact your local authorities for approved disposal methods or possible recycling.

Oil Filter Change

- Change the oil filter every 200 hours of operation.

⚠ WARNING

Hot engine oil can cause severe burns. Allow engine temperature to drop from hot to warm level before draining and handling oil.

- Drain engine oil into a suitable container.

NOTICE

Before removing the oil filter, place suitable pan under filter connection.

- Rotate the oil filter (A) counterclockwise to remove it.
- Coat a film of clean engine oil on seal of new filter.
- Install new filter rotating it clockwise until seal contacts mounting surface (B). Then rotate filter 3/4 turn more by hand.
- Supply engine oil as specified.
- Run the engine for about 3 minutes, stop engine, and check oil leakage around the filter.
- Add oil to compensate for oil level drop due to oil filter capacity (See “PREPARATION” chapter for oil level check).

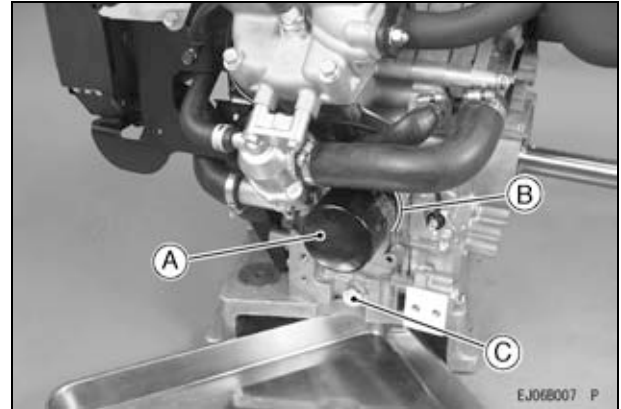

- A. Oil Filter
- B. Contact Surface
- C. Oil Drain Plug

⚠ WARNING

Engine oil is a toxic substance. Dispose of used oil properly. Contact your local authorities for approved disposal methods or possible recycling.

28 MAINTENANCE

Cooling System Inspection

Inspect the radiator and the hoses every 200 hours of operation.

- Inspect the inlet and outlet hoses (A) for cracks or deterioration, and connections for looseness. Replace any damaged hose.
- Check for dirt and insects that may be lodged in the radiator (B). Clean them out by using compressed air or a low-pressure washer.

NOTICE

Using high-pressure water, as from a car wash facility, could damage the radiator fins and impair the radiator's effectiveness. Do not run engine before all cooling system parts are reinstalled to keep cooling and carburetion as intended.

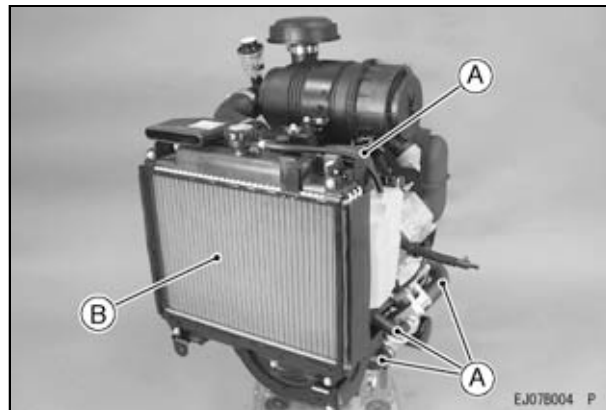

- A. Inlet and Outlet Hoses
- B. Radiator and Radiator Screen

⚠ WARNING

Coolant is a toxic substance. Dispose of used coolant properly. Contact your local authorities for approved disposal methods.

Air Cleaner Service

This air cleaner elements are not recommended to be cleaned, and each air cleaner element should be replaced with the new one at the maintenance time as shown in the maintenance chart.

NOTICE

Improper installing the air cleaner parts can result in engine damage.

NOTICE

To prevent excessive engine wear, do not run the engine with the air cleaner parts removed.

- Unfasten the two retaining clamps (A) and remove the case (B) from the air cleaner body (C).
- Remove the primary element (D) and the secondary element (E) from the air cleaner body by pulling out them.
- Install the new air cleaner elements into the air cleaner body.
- Reinstall the case with the cap (F) is down and securely fasten the two retaining clamps.

Primary Element

Replace the primary element every 250 hrs.

Secondary Element

Replace the secondary element every 500 hrs.

Replace the secondary element with the new one if dirty when primary element is checked.

Cap (Dust Ejector Valve)

Push open the cap (F) on the case of the air cleaner body to expel dust and/or water accumulated inside.

NOTE

- *Operating in dusty condition may require more frequent maintenance than above.*

NOTICE

**Do not wash air cleaner elements.
Do not oil air cleaner elements.
Do not use pressurized air to clean air cleaner elements.**

30 MAINTENANCE

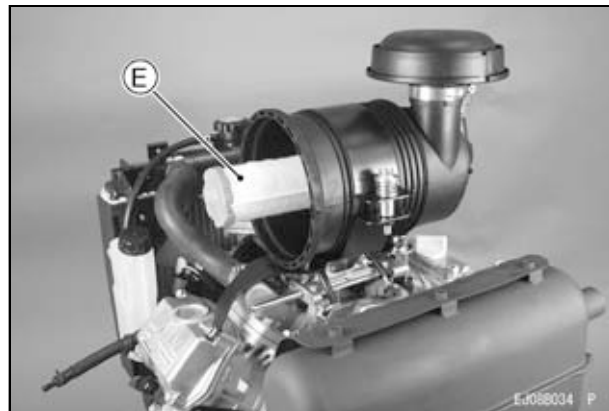
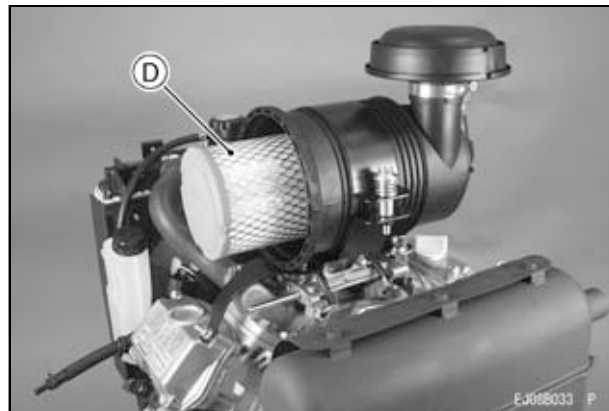
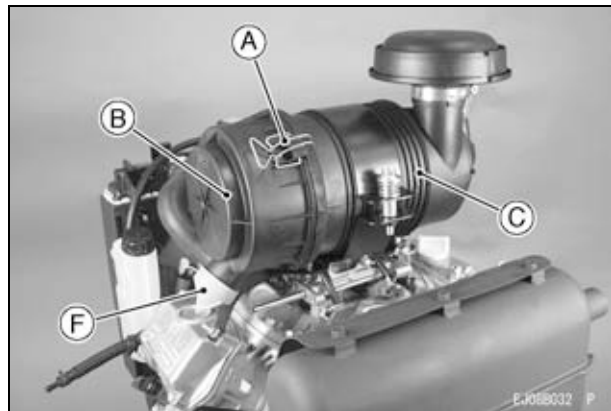

- A. Clamps
- B. Air Cleaner Case
- C. Air Cleaner Body
- D. Primary Element
- E. Secondary Element
- F. Cap

Fuel Filter and Fuel Pump Service

 WARNING

Many solvents are highly flammable and may cause serious burns. Improper use of solvents can result in fire or an explosion. Do not use gasoline or low flash-point solvents to clean the fuel filter and/or the fuel pump. Clean only in a well-ventilated area away from sources of sparks or flame, including any appliances with a pilot light.

- The fuel filter and the fuel pump can not be disassembled.
If these parts failed contact Kawasaki dealer.

32 MAINTENANCE

Spark Plug Service

WARNING

Engines can become extremely hot during normal operation. Hot engine components can cause severe burns. Stop the engine and allow it to cool before checking spark plugs.

Clean or replace the spark plugs and reset gap (A) every 100 hours of operation.

- Disconnect the spark plug caps and remove the spark plugs.
- Clean the electrodes (B) by scraping with a wire brush to remove carbon deposits.
- Inspect for cracked porcelain or other wear and damage. Replace the spark plugs with a new one if necessary.
- Check the spark plug gap and reset it if necessary. The gap must be 0.75 mm (0.030 in). To change the gap, bend only the side-electrode, using a spark plug tool.

- Install and tighten the spark plug to 25 N·m (2.5 kgf·m, 18 ft·lb).
- Fit the spark plug caps on the spark plug securely.
- Pull up the spark plug caps lightly to make sure of the installation of the spark plug caps.

RECOMMENDED SPARK PLUG

NGK BPR4ES

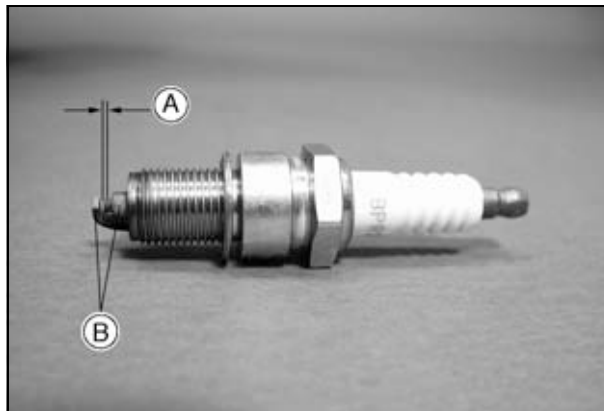

STORAGE

Fuel System Draining

Engines to be stored over 30 days should be completely drained of fuel to prevent the deterioration of fuel and the gum deposits forming on essential fuel system parts, fuel filter and fuel tank.

WARNING

Gasoline is extremely flammable and can be explosive under certain conditions. Drain fuel before storing the equipment for extended periods. Drain gasoline in a well-ventilated area away from any source of flame or sparks, including any appliances with a pilot light. Store gasoline in an approved container in safe location.

- Clean every part of the engine.
- Be sure that the engine switch or switch key is positioned at “OFF”.
- Close the fuel valve and remove the sediment bowl.
- Put a pan under the fuel valve to receive the drained fuel, and open the fuel valve to drain the fuel from fuel tank completely.

WARNING

Gasoline is toxic and pollutes the environment. To protect the environment, do not discard gasoline; always return it to an authorized recycling center.

- Remove the spark plugs and pour approx 1 ~ 2 mL (0.06 ~ 0.1 cu. in.) of engine oil through the spark plug holes and then screw the spark plugs in after turning the engine a few times. Slowly turn the engine until you feel compression and then leave it there. This traps the air inside the cylinders and prevents rust inside the engine.
- Fit the spark plug caps on the spark plugs securely.
- Pull up the spark plug caps lightly to make sure of the installation of the spark plug caps.
- Wipe the body with oily cloth.
- Wrap the engine with plastic sheeting and store it in a dry place.
- Change engine oil for next use after period of storage (Refer to “Oil change” section in “MAINTENANCE” chapter).

TROUBLESHOOTING GUIDE

If the engine malfunctions, carefully examine the symptoms and the operating conditions, and use the table below as a guide to troubleshooting.

Symptom		Probable Cause	Remedy
Engine won't start or output is low	Insufficient compression	Faulty pistons, cylinders, piston rings, and head gaskets	K
		Faulty valves	
		Loose spark plugs	Tighten properly
		Loose cylinder head bolts	
	No fuel to combustion chambers	No fuel in fuel tank	Fill fuel tank
		Fuel valve not in "ON" position	Open fuel valve.
		Blocked fuel filter or tube	Clean
		Blocked air vent in tank cap	
	Faulty carburetor and/or DFI system	K	
	Spark plugs fouled by fuel	Over-rich fuel/air mixture	Open choke.
			Rotate engine with spark plugs removed to discharge excess fuel.
			Clean spark plugs.
		Clogged air cleaner	Clean
		Faulty carburetor and/or DFI system	K
Incorrect grade/type of fuel	Change fuel		

Symptom		Probable Cause	Remedy
		Water in fuel	
	No spark or weak spark	Faulty spark plugs	Replace spark plugs
		Faulty ignition coils	K
Low output	Engine overheats	Clogged air cleaner	Clean
		Lodged dirt and insects in radiator	
		Lack of coolant	Add coolant to correct level
		Insufficient engine oil	Replenish or change oil
		Loose or slipping fan belt	K
		Carbon build-up in combustion chamber	
		Poor ventilation around engine	Select a better location
	Engine speed won't increase	Faulty governor	K

K : Have an authorized Kawasaki dealer perform these service.

ENVIRONMENTAL PROTECTION

To protect our environment, properly discard used batteries, engine oil, gasoline, coolant, or other components that you might dispose of in the future.

Consult your authorized Kawasaki dealer or local environmental waste agency for their proper disposal procedure. This also applies to disposal of the entire engine at the end of its life.

SPECIFICATIONS

	FD851D
Type of engine	Liquid-cooled, 4-stroke OHV, V-twin cylinder, gasoline engine
Bore x Stroke	82 × 78 mm (3.23 × 3.07 in.)
Displacement	824 mL (50.3 cu.in)
Ignition System	Solid-state ignition
Direction of rotation	Counterclockwise facing the PTO Shaft
Starting system	Electric starter
Dry weight : kg (lbs)	57.5 kg (127 lbs)

NOTE

- *Specifications subject to change without notice.*
- *Dry weight excludes that of fuel tank.*



WARNING:



The engine exhaust from this product contains chemicals known to the State of California to cause cancer, birth defects or other reproductive harm.

Engine oil is a toxic substance. Dispose of used oil properly. Contact your local authorities for approved disposal methods or possible recycling.

For repair/warranty assistance please contact your local Kawasaki Authorized Dealer, email kawpower-website@kmc-usa.com or call toll-free 1-877-364-6404

Gasoline is a toxic substance. Dispose of gasoline properly. Contact your local authorities for approved disposal methods.

Kawasaki

Engines