

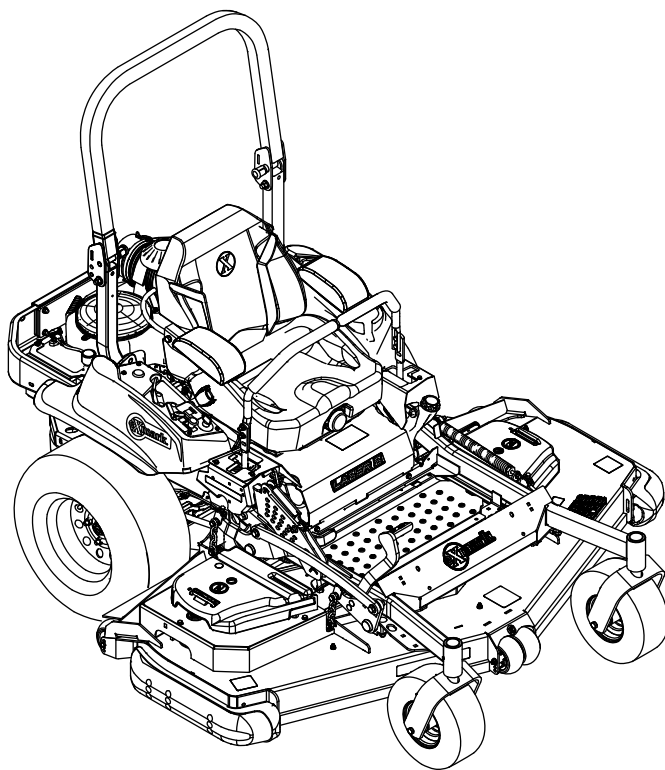

LAZER Z[®] S-SERIES

Model No. LZS801CKA60RA1—Serial No. 411294212 and Up

Picture below may not reflect actual product.



Parts Manual

Part No. 4505-968 Rev. A

Ordering Replacement Parts

To order replacement parts, please supply the part number, the quantity, and the description of each part desired.

Understanding Reference Numbers

Each identified part in an illustration has a reference number. The reference number for a part also appears in the parts list, along with other information about the part.

This catalog uses two special reference number formats, one to indicate parts in a service assembly and another to indicate the quantity of a given part in an illustration.

Service Assembly Reference Numbers

Parts in service assemblies have reference numbers in the form a:b. The a represents the reference number of the entire service assembly and the b represents a sequential number unique to each part within the service assembly.

For example, a wheel assembly might be identified by reference number 6, the tire by 6:1, the valve by 6:2, and the wheel by 6:3. When you order the assembly identified by reference number 6, you receive all parts identified by reference numbers 6:1, 6:2, and 6:3. However, you may also order any part individually. Reference numbers of this type appear in illustration and in parts lists.

Reference Numbers Indicating Quantity

In an illustration, if a reference number indicates more than one part, the reference number has the form nX y. The n represents the quantity of the part, the X is the multiplication symbol, and the y represents the reference number.

For example, in an illustration, the reference number 2X 37 means that two of the parts identified by reference number 37 are indicated.

Touch Up Paint

Exmark black touch up spray paint – gloss black.

Exmark red touch up paint (spray paint – P/N 1-850337 - .6 oz liquid bottle – P/N 103-9140).

Contents

| | |
|--|----|
| Complete Deck Assembly | 4 |
| Deck Assembly | 6 |
| Deck W/Decals Assembly | 8 |
| Idler Assembly No. 126-0853 | 10 |
| Deck Idler Assembly No. 126-1720 | 12 |
| Rear Discharge Tunnel Assembly | 14 |
| Discharge Tunnel Assembly No. 126-4930 | 16 |
| Main Frame Assembly | 18 |
| S-Series Decal | 20 |
| Roll-Over Protection System | 22 |
| Roll Over Protection System (cont.) | 24 |
| Front Caster and Fork Assembly | 26 |
| Caster Wheel and Fork Assembly | 28 |
| Deck Lift Assembly | 30 |
| Height-of-Cut Assembly No. 109-7438 | 32 |
| Controls Assembly | 34 |
| Motion Control Assembly | 36 |
| Rear Wheel Assembly | 38 |
| Park Brake Assembly | 40 |
| Seat Assembly | 42 |
| Seat Assembly (cont.) | 44 |
| Fuel System Assembly | 46 |
| Fuel Tank Assembly | 48 |
| Engine Assembly | 50 |
| Hydraulic Assembly | 52 |
| LH Hydro Assembly No. 135-7903 | 54 |
| RH Hydro Assembly No. 135-7904 | 56 |
| Pump Idler Assembly No. 116-1255 | 58 |
| Electrical Assembly | 60 |

Complete Deck Assembly

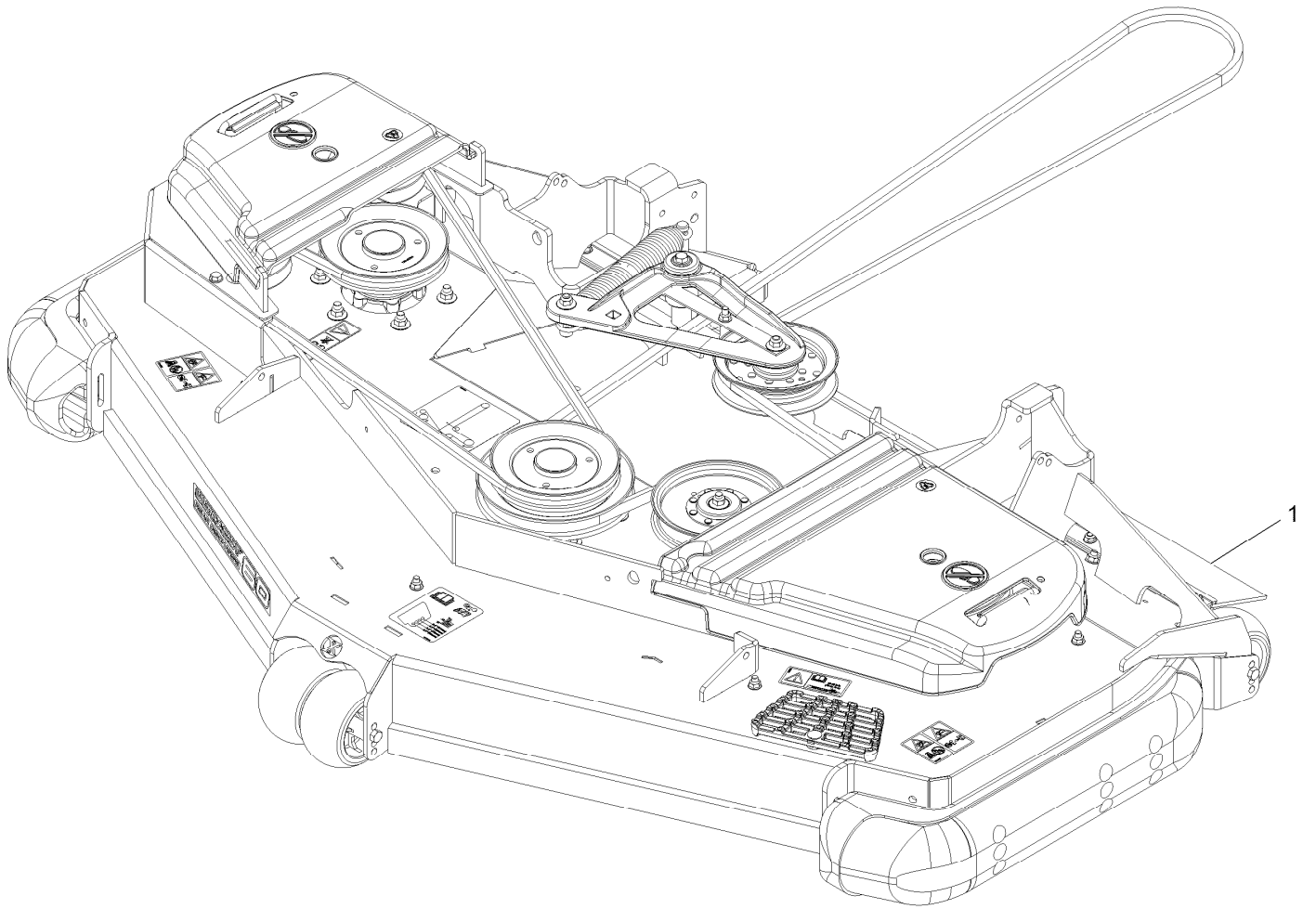

Complete Deck Assembly (continued)

| <i>Ref.</i> | <i>Part Number</i> | <i>Qty.</i> | <i>Description</i> |
|-------------|--------------------|-------------|-------------------------------|
| 1 | 126-0376 | 1 | ASM-Deck Complete Rd60 Nlz |

Deck Assembly

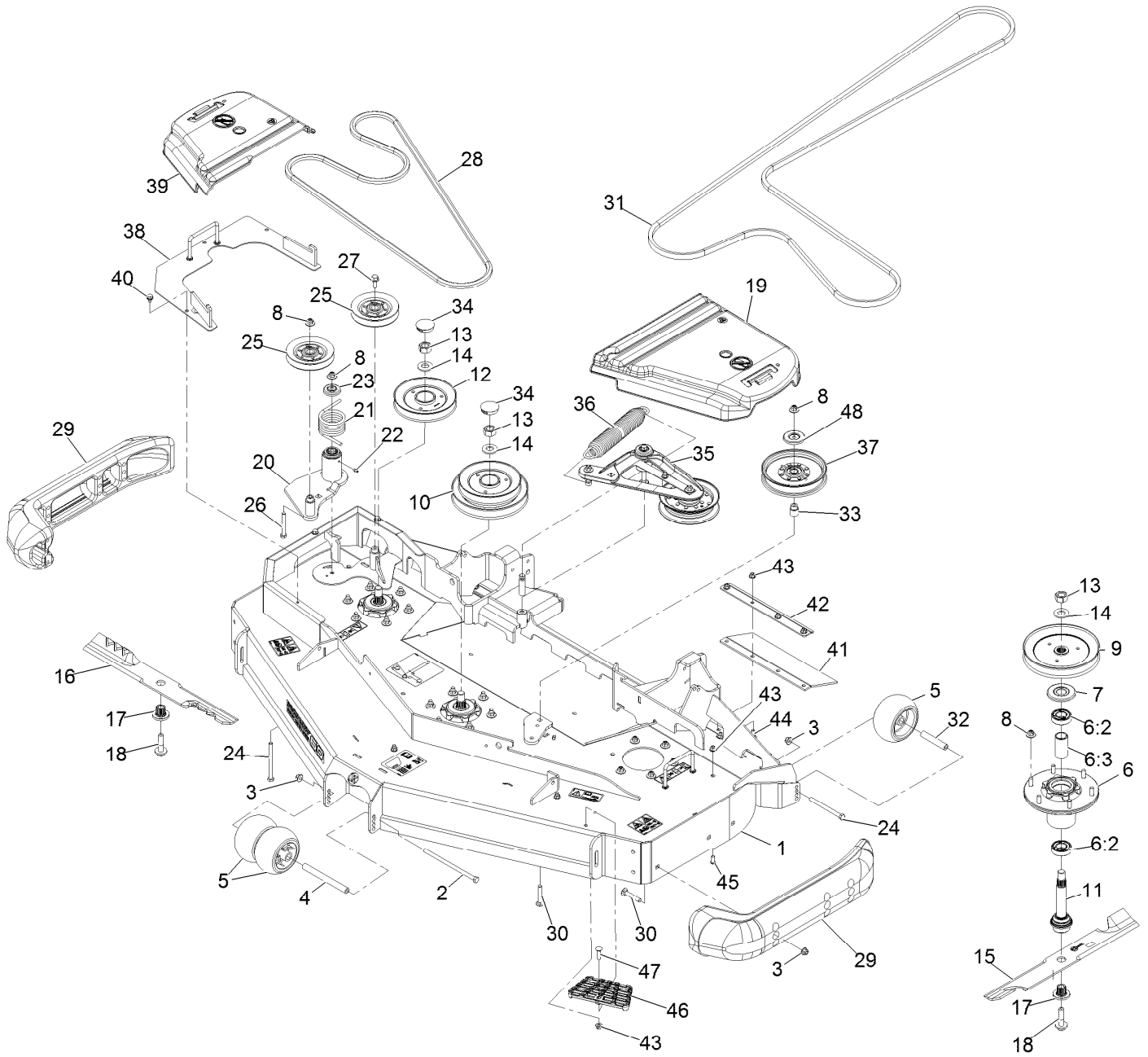

Deck Assembly (continued)

| <i>Ref.</i> | <i>Part Number</i> | <i>Qty.</i> | <i>Description</i> | <i>Ref.</i> | <i>Part Number</i> | <i>Qty.</i> | <i>Description</i> |
|-------------|--------------------|-------------|--------------------------------|-------------|--------------------|-------------|---------------------------------|
| 1 | 116-9839 | 1 | Deck-Rd60 Nlz, W/Decals | 22 | 302-19 | 1 | Zerk-1/4-28 Str |
| 2 | 108-5388 | 1 | Screw-HH 3/8-16 X 7 3/8 | 23 | 103-2916 | 1 | Guard-Top |
| 3 | 104-8301 | 9 | Nut-Nyloc 3/8-16 Flg | 24 | 323-23 | 3 | Screw-HH 3/8-16 X 4-1/2 |
| 4 | 98-5967 | 1 | Spacer-Wheel | 25 | 126-1478 | 2 | Sheave |
| 5 | 1-603299 | 4 | Roller-Scalp, Anti | 26 | 323-13 | 1 | Screw-HH 3/8-16 X 2 3/4 |
| 6 | 116-3344 | 3 | ASM-Cutter Hsg With Bearings | 27 | 3234-11 | 1 | Screw-HH Flg 3/8-16 X 1 |
| 6:2 | 116-0720 | 2 | Bearing-Ball | 28 | 116-8187 | 1 | Belt |
| 6:3 | 116-3312 | 1 | Spacer-Bearing | 29 | 112-1479 | 2 | Skid-Bumper, Deck |
| 7 | 116-1286 | 3 | Guard,Bearing Top .989 | 30 | 3231-7 | 7 | Bolt-Carriage 3/8-16 X 2 1/4 |
| 8 | 109-6658 | 21 | Nut-Nyloc 3/8-16 Flg | 31 | 125-9371 | 1 | Belt |
| 9 | 116-0676 | 1 | Sheave,Blade Drive 7.25 | 32 | 98-7912 | 2 | Tube-Spanner |
| 10 | 126-0352 | 1 | Sheave, Double 60Rd | 33 | 1-633456 | 1 | Bushing, Idler |
| 11 | 116-3341 | 3 | ASM-Spindle And Seal | 34 | 116-2253 | 2 | Plug,Black Nylon 1.75 |
| 12 | 126-0354 | 1 | Sheave-Rd Rev Drive Series 4 | 35 | 126-1720 | 1 | Deck Idler ASM |
| 13 | 116-7306 | 3 | Nut-Hex ▲ | 36 | 116-6317 | 1 | Spring-Extension |
| 14 | 103-2802 | 3 | Washer-Spring Disc 3/4 | 37 | 126-9189 | 1 | Idler-Pulley, Flat 6.00X1.00 |
| 15 | 116-5174 | 2 | Blade-Extreme 2, 20.50" ● | 38 | 116-8195-01 | 1 | Cover-Drive Reverse |
| 15 | 103-6403 | 2 | Blade, Notched | 39 | 116-8190 | 1 | Cover-Belt, RH |
| 15 | 103-6388 | 2 | Blade, Low Lift ● | 40 | 9266934 | 3 | Screw-HWH 5/16 X 1/2 Tf |
| 16 | 116-8196 | 1 | Blade-Low Lift 20.5, Rd60 ● | 41 | 116-8191 | 2 | Guard-Tire |
| 16 | 116-8181 | 1 | Blade-Extreme 2-20.50, Rd60 | 42 | 126-0413-01 | 2 | Support-Outer Flap |
| 17 | 103-3037 | 3 | Bushing, Splined | 43 | 104-8300 | 15 | Nut-Nyloc 5/16-18 Flg |
| 18 | 109-9220 | 3 | Screw-Sems 1/2-20 X 2.19 ◆■ | 44 | 3230-16 | 8 | Bolt-Carriage 5/16-18 X 7/8 |
| 19 | 109-6938 | 1 | Cover-Belt, LH | 45 | 3274-55 | 6 | Screw-Button Head 5/16-18 X 3/4 |
| 20 | 126-0853 | 1 | Idler ASM | 46 | 126-4781-03 | 1 | Step-Deck |
| 21 | 108-1921 | 1 | Spring-Torsion | 47 | 3230-3 | 1 | Bolt-Carriage 5/16-18 X 1 1/4 |
| | | | | 48 | 126-8043 | 1 | Shield-Dust |

● Optional Equipment

▲ Torque to 130-160 ft-lb

◆ Apply lubricant to threads as needed to prevent seizing. Copper based anti-seize preferable. Grease is an acceptable substitute.

■ Torque to 55-60 ft-lb

Deck W/Decals Assembly

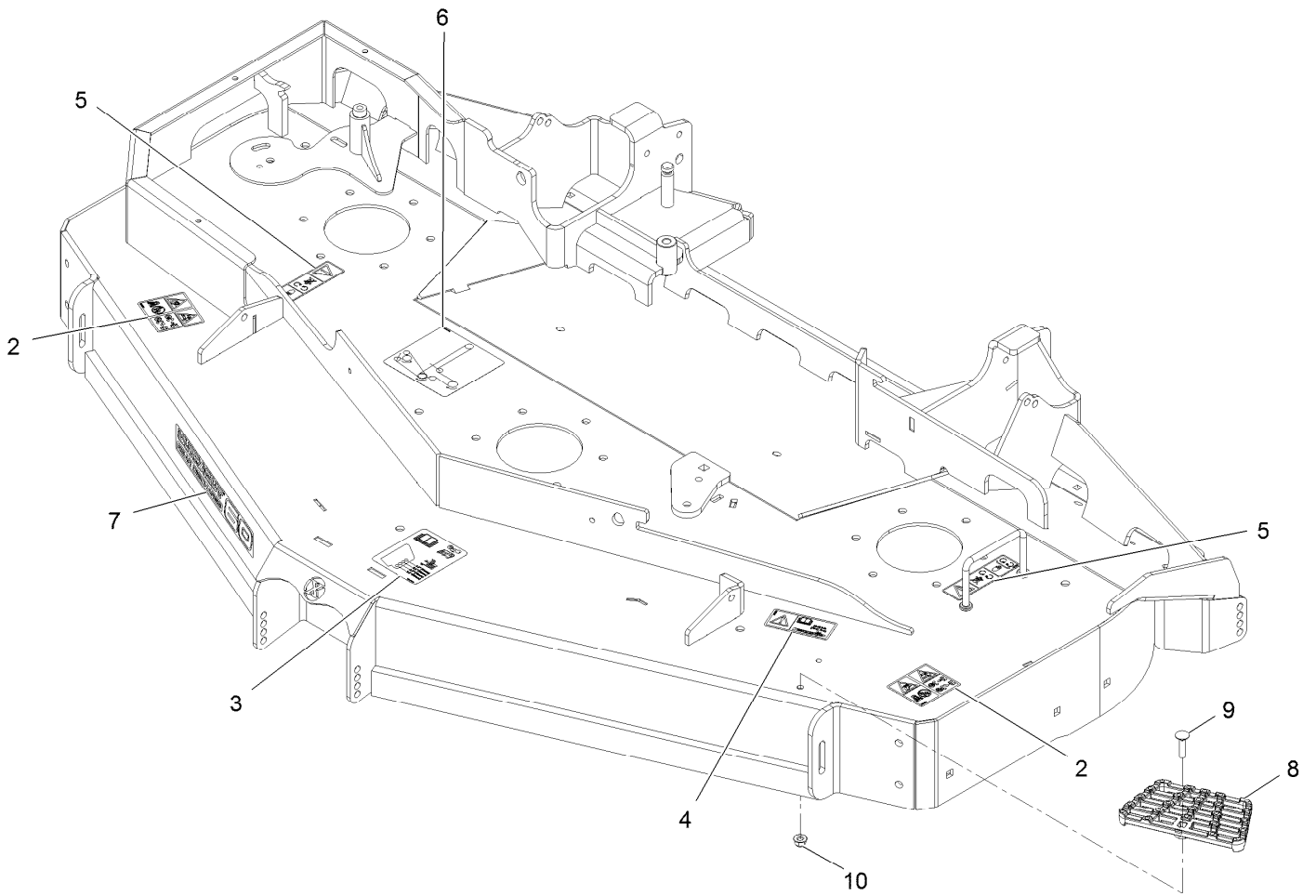

Deck W/Decals Assembly (continued)

| <i>Ref.</i> | <i>Part Number</i> | <i>Qty.</i> | <i>Description</i> | <i>Ref.</i> | <i>Part Number</i> | <i>Qty.</i> | <i>Description</i> |
|-------------|--------------------|-------------|-----------------------------|-------------|--------------------|-------------|---------------------|
| 2 | 135-0664 | 2 | Decal-Danger, Thrown Object | 6 | 126-0768 | 1 | Decal-Routing, Belt |
| 3 | 109-6036 | 1 | Decal-Roller, Anti-Scalp | 7 | 126-6596 | 1 | Decal, 60Rd |
| 4 | 116-8283 | 1 | Decal-Torque, Bolt | 8 | 126-4781-03 | 1 | Step-Deck |
| 5 | 112-9028 | 2 | Decal-Cover, Missing | 9 | 3230-3 | 1 | Screw-CARR |
| | | | | 10 | 104-8300 | 1 | Nut-HF, NI |

Idler Assembly No. 126-0853

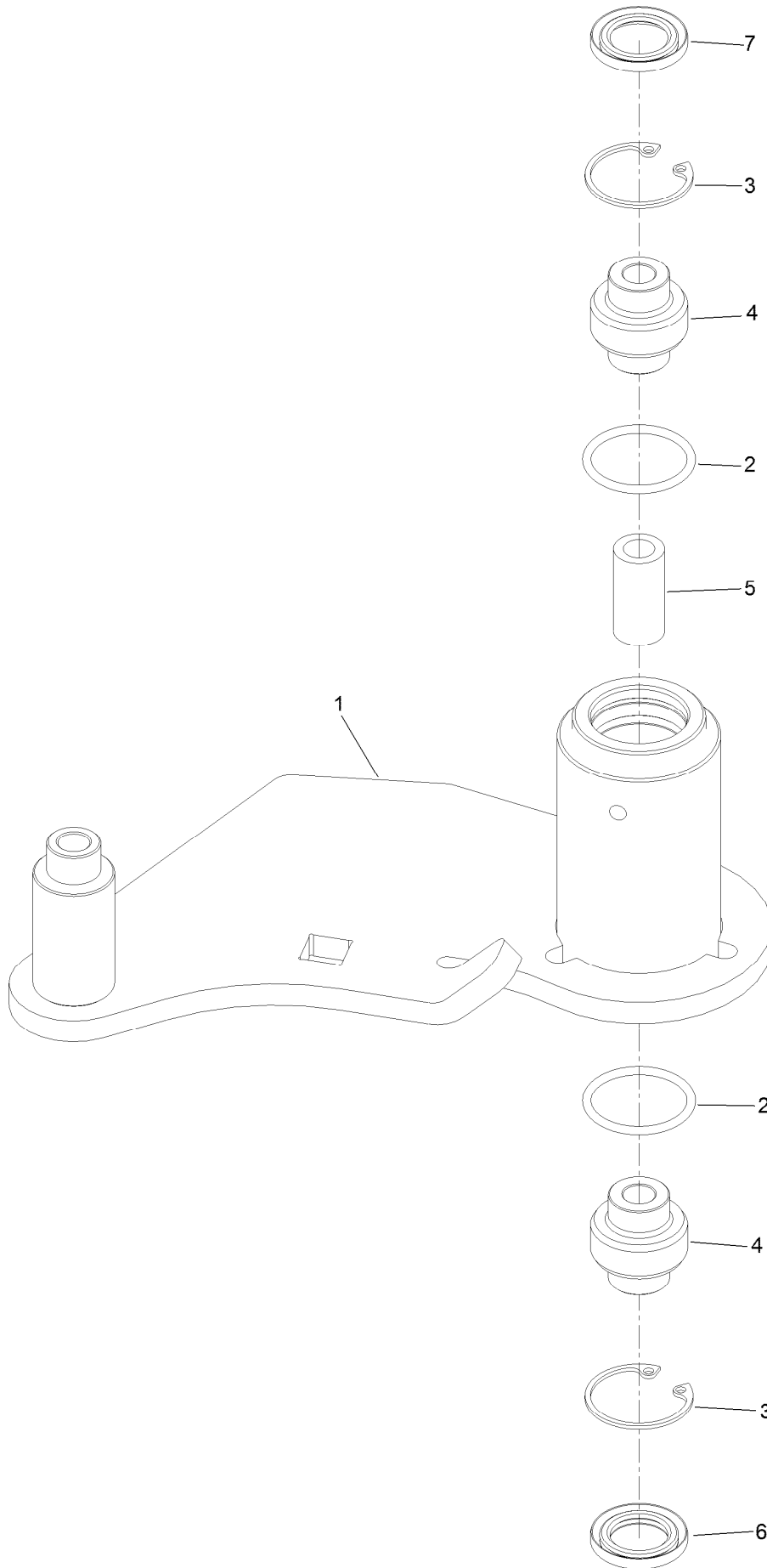

Idler Assembly No. 126-0853 (continued)

| <i>Ref.</i> | <i>Part Number</i> | <i>Qty.</i> | <i>Description</i> |
|-------------|--------------------|-------------|--------------------|
| 1 | | 1 | Idler-Deck ● |
| 2 | 106-7159 | 2 | O-Ring |
| 3 | 32120-10 | 2 | Ring-Snap |
| 4 | 103-3504 | 2 | Bearing-Spherical |

| <i>Ref.</i> | <i>Part Number</i> | <i>Qty.</i> | <i>Description</i> |
|-------------|--------------------|-------------|--------------------|
| 5 | 108-6544 | 1 | Spacer |
| 6 | 103-3505 | 1 | Seal-Lip, Double |
| 7 | 103-3506 | 1 | Seal-Lip, Single |

● Not serviced separately

Deck Idler Assembly No. 126-1720

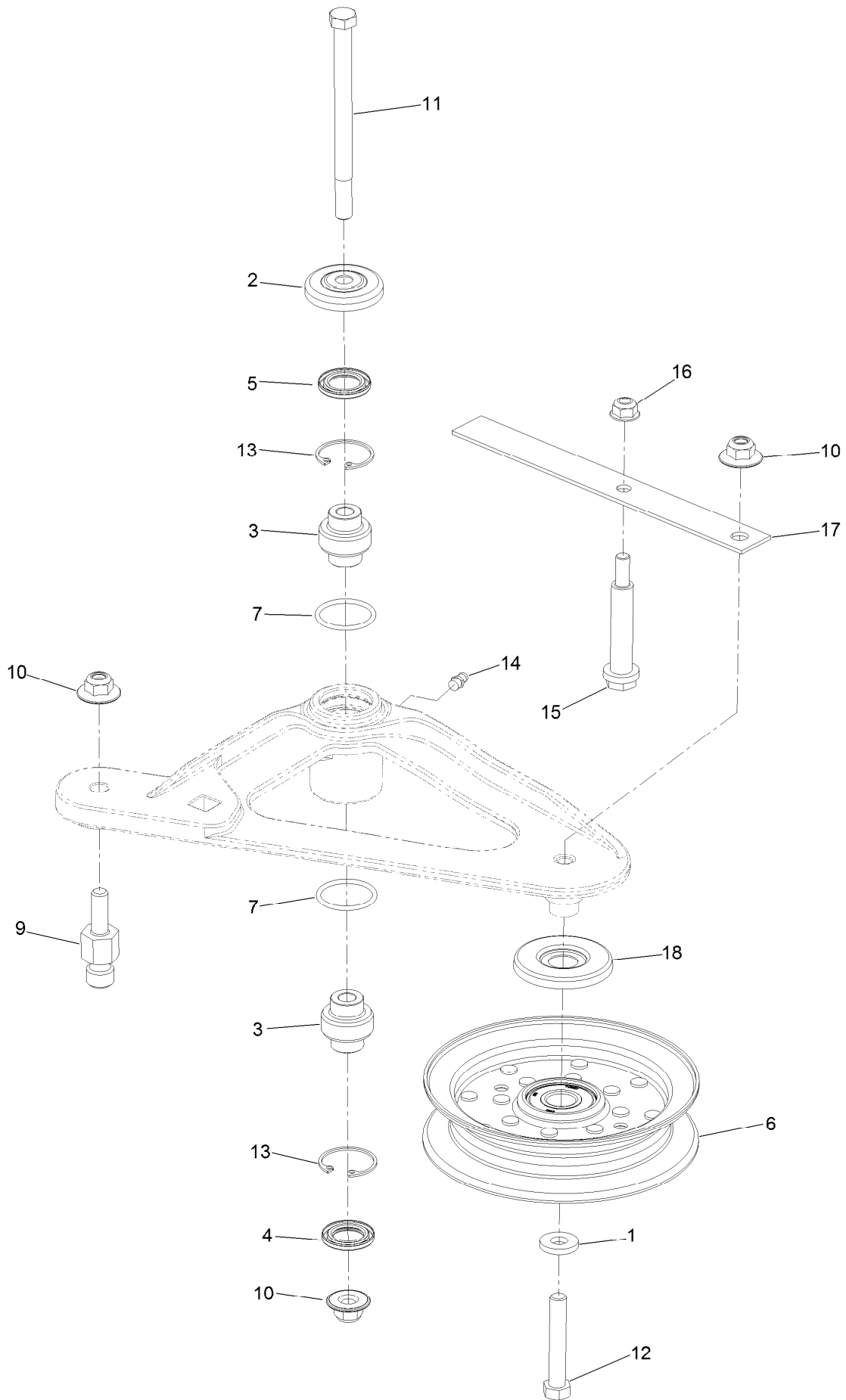

Deck Idler Assembly No. 126-1720 (continued)

| <i>Ref.</i> | <i>Part Number</i> | <i>Qty.</i> | <i>Description</i> | <i>Ref.</i> | <i>Part Number</i> | <i>Qty.</i> | <i>Description</i> |
|-------------|--------------------|-------------|--------------------|-------------|--------------------|-------------|--------------------|
| 1 | 43-0940 | 1 | Spacer | 11 | 109-7409 | 1 | Screw-Shoulder, HH |
| 2 | 103-2916 | 1 | Guard-Top | 12 | 104-3396 | 1 | Screw-HH |
| 3 | 103-3504 | 2 | Bearing-Spherical | 13 | 32120-10 | 2 | Ring-Snap |
| 4 | 103-3505 | 1 | Seal-Lip, Double | 14 | 302-19 | 1 | Fitting-Grease |
| 5 | 103-3506 | 1 | Seal-Lip, Single | 15 | 88-4590 | 1 | Bolt-Shoulder |
| 6 | 126-9196 | 1 | Idler-Pulley, Flat | 16 | 104-8300 | 1 | Nut-HF, NI |
| 7 | 106-7159 | 2 | O-Ring | 17 | 126-1704 | 1 | Spring-Belt |
| 9 | 126-0423 | 1 | Pin-Spring, Anchor | 18 | 126-9195 | 1 | Shield-Guard, Dust |
| 10 | 109-6658 | 3 | Nut-Flange, NI | | | | |

Rear Discharge Tunnel Assembly

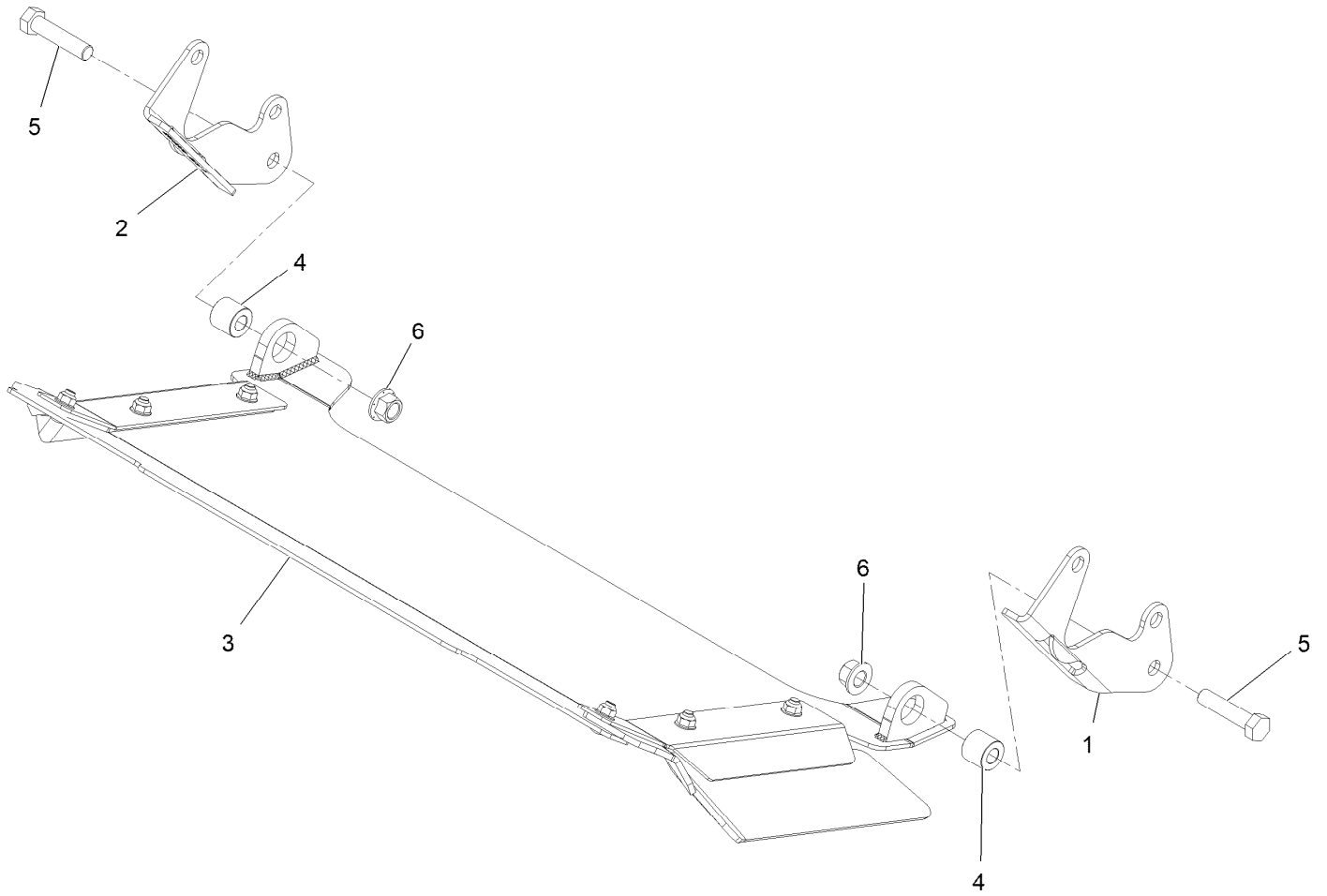

Rear Discharge Tunnel Assembly (continued)

| <i>Ref.</i> | <i>Part Number</i> | <i>Qty.</i> | <i>Description</i> | <i>Ref.</i> | <i>Part Number</i> | <i>Qty.</i> | <i>Description</i> |
|-------------|--------------------|-------------|--------------------------------|-------------|--------------------|-------------|----------------------|
| 1 | 125-9369-03 | 1 | Bracket-Discharge Mount, LH | 3 | 126-4930 | 1 | Discharge Tunnel ASM |
| 2 | 125-9370-03 | 1 | Bracket-Discharge Mount, RH | 4 | 126-1705 | 2 | Bushing-Sleeve |
| | | | | 5 | 325-9 | 2 | Screw-HH |
| | | | | 6 | 99-5107 | 2 | Nut-Lock |

Discharge Tunnel Assembly No. 126-4930

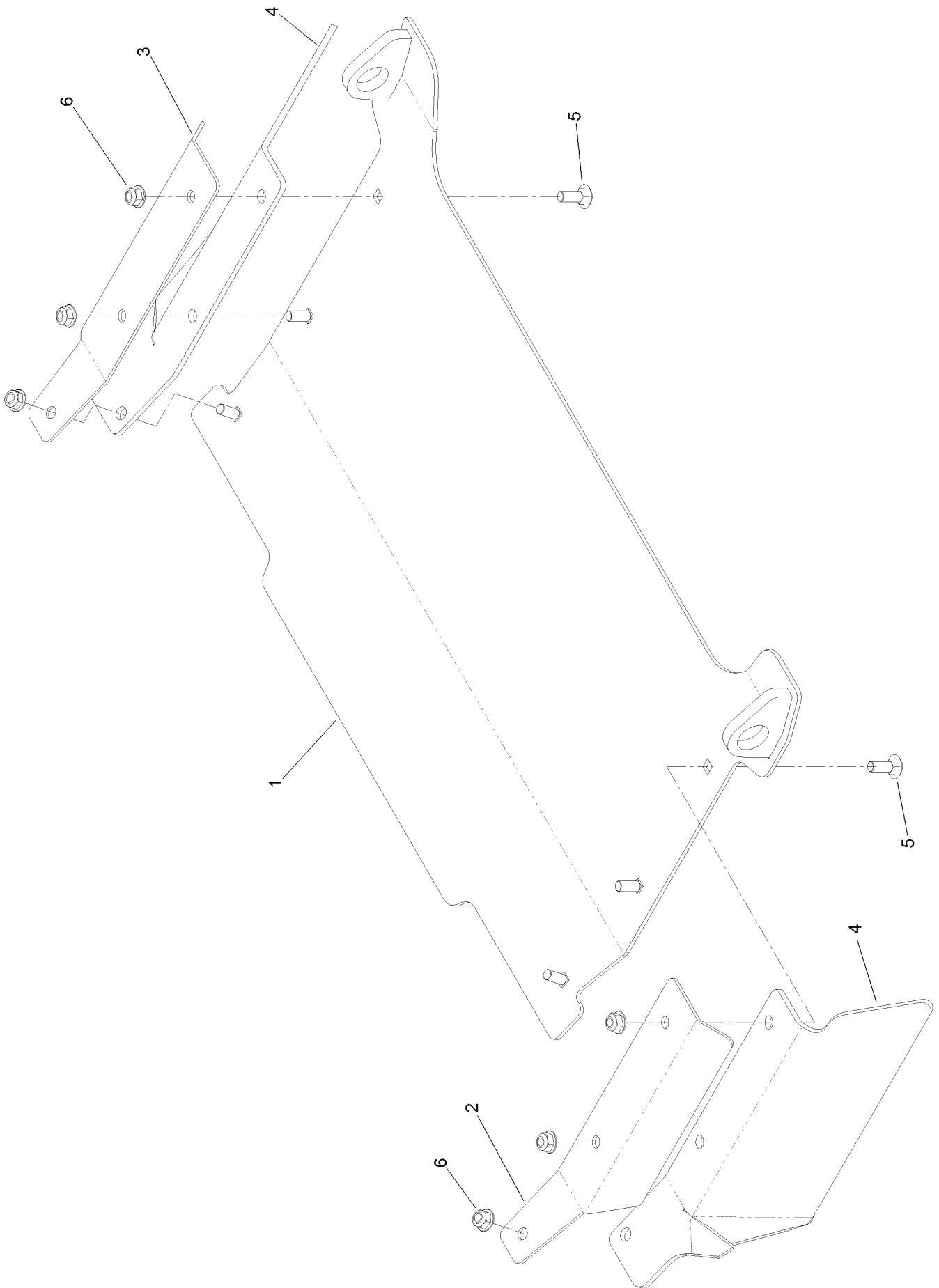

Discharge Tunnel Assembly No. 126-4930 (continued)

| <i>Ref.</i> | <i>Part Number</i> | <i>Qty.</i> | <i>Description</i> | <i>Ref.</i> | <i>Part Number</i> | <i>Qty.</i> | <i>Description</i> |
|-------------|--------------------|-------------|----------------------|-------------|--------------------|-------------|--------------------|
| 1 | 126-4929-03 | 1 | Discharge Tunnel ASM | 4 | 125-9368 | 2 | Flap-Rubber |
| 2 | 125-9366-03 | 1 | Bracket-Flap, LH | 5 | 3230-16 | 6 | Screw-CARR |
| 3 | 125-9367-03 | 1 | Bracket-Flap, RH | 6 | 104-8300 | 6 | Nut-HF, NI |

Main Frame Assembly

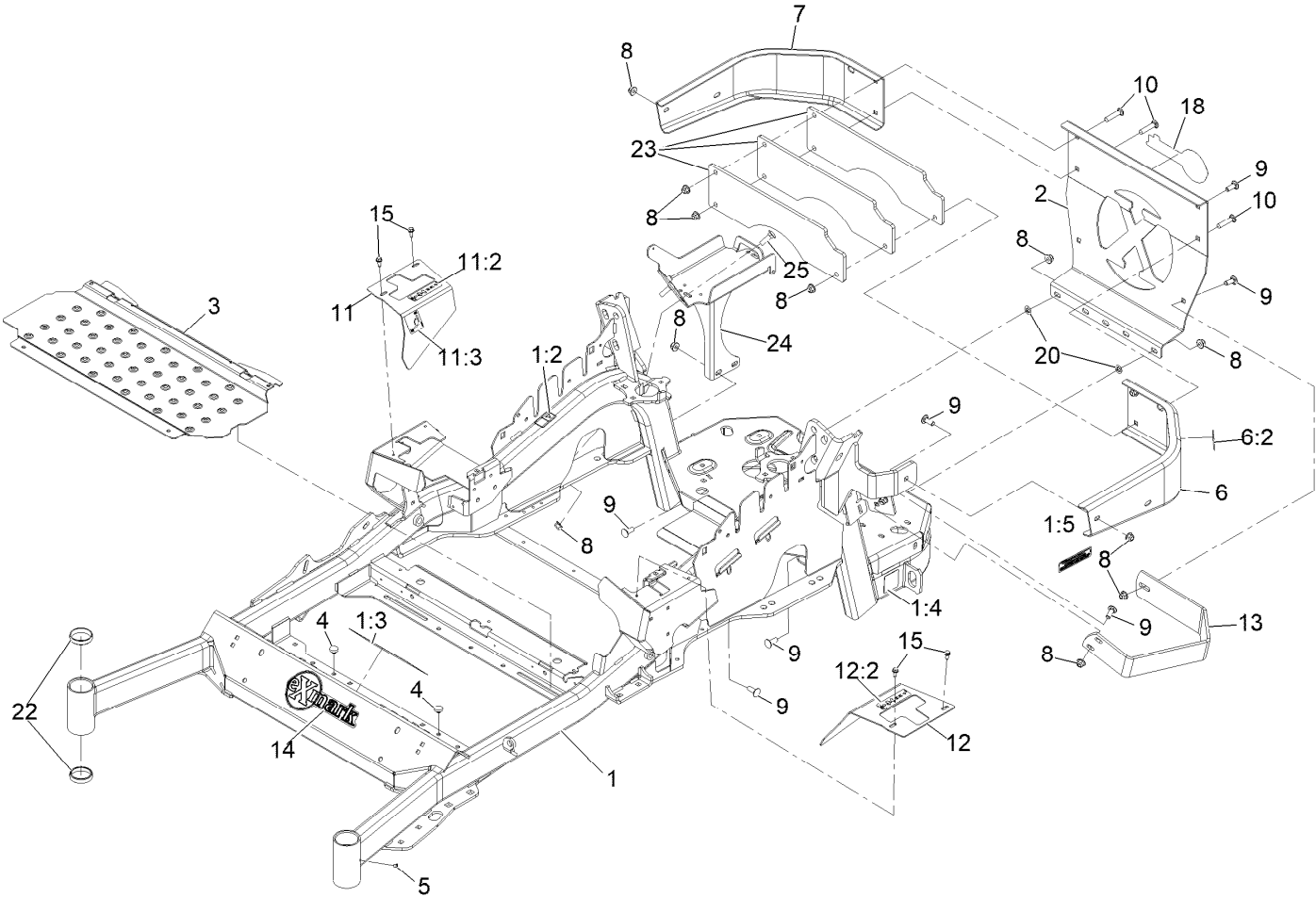

Main Frame Assembly (continued)

| <i>Ref.</i> | <i>Part Number</i> | <i>Qty.</i> | <i>Description</i> | <i>Ref.</i> | <i>Part Number</i> | <i>Qty.</i> | <i>Description</i> |
|-------------|--------------------|-------------|------------------------------|-------------|--------------------|-------------|------------------------------|
| 1 | 142-7280 | 1 | Mainframe Service ASM - Rd | 11 | 116-5899 | 1 | RH Motion Control Cover ASM |
| 1:2 | 106-5517 | 2 | Decal-Warning | 11:2 | 99-8936 | 1 | Decal-Control, Motion |
| 1:3 | 132-0871 | 1 | Decal-Danger | 11:3 | 116-5988 | 1 | Decal-Park Brake, CE |
| 1:4 | 106-2655 | 2 | Decal-Hazard, Pinched Finger | 12 | 116-0580 | 1 | LH Motion Control Cover ASM |
| 1:5 | 133-8062 | 1 | Decal-Arrestor, Spark | 12:2 | 99-8936 | 1 | Decal-Control, Motion |
| 2 | 109-8863-03 | 1 | Plate,Rear Guard | 13 | 126-2067-03 | 1 | Guard-Muffler |
| 3 | 116-8898-01 | 1 | Floorpan | 14 | 135-2274 | 1 | Decal-Exmark |
| 4 | 1-513658 | 2 | Bumper | 15 | 32144-10 | 4 | Screw-HWH 1/4-20 X .62 |
| 5 | 1-811010 | 2 | Plug | 18 | 126-6877 | 1 | Decal, Exmark Logo |
| 6 | 116-0180 | 1 | LH Bumper ASM | 20 | 107-3154 | 2 | Nut-Push 3/8-16 |
| 6:2 | 106-5517 | 1 | Decal-Warning | 22 | 1-543508 | 4 | Cup-Bearing Tapered Roller |
| 7 | 116-0057-03 | 1 | Bumper-RH | 23 | 126-4772-03 | 3 | Plate-Weight, 6 Lb |
| 8 | 104-8301 | 15 | Nut-Nyloc 3/8-16 Flg | 24 | 142-6404-01 | 1 | Battery Mount ASM [red] |
| 9 | 3231-22 | 10 | Bolt-Carriage 3/8-16 X 1 | 25 | 3231-25 | 2 | Bolt-Carriage 3/8-16 X 1 1/4 |
| 10 | 3231-29 | 3 | Bolt-Carriage 3/8-16 X 1 3/4 | | | | |

S-Series Decal

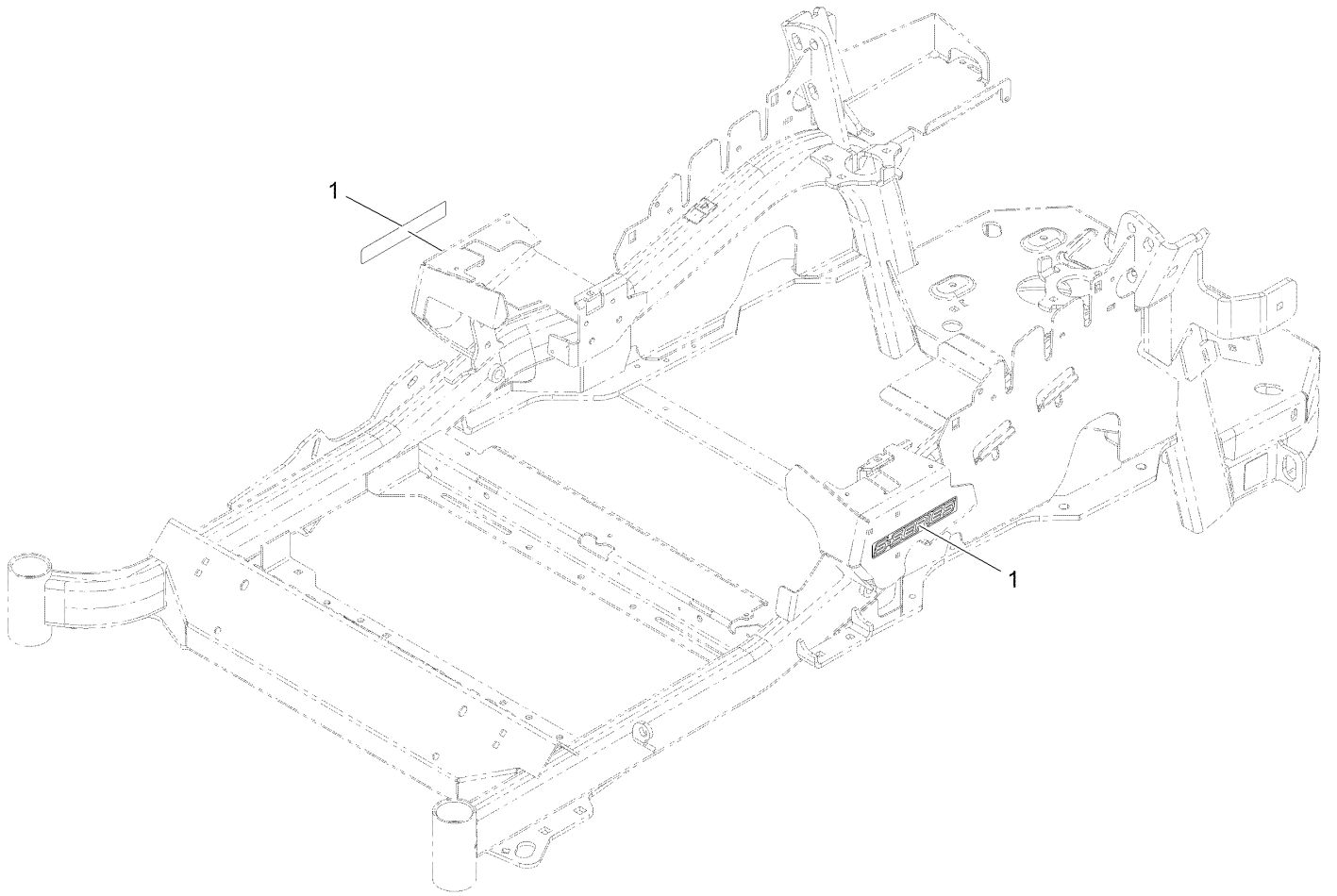

S-Series Decal (continued)

| <i>Ref.</i> | <i>Part Number</i> | <i>Qty.</i> | <i>Description</i> |
|-------------|--------------------|-------------|--------------------|
| 1 | 126-6572 | 2 | Decal-S-Series |

Roll-Over Protection System

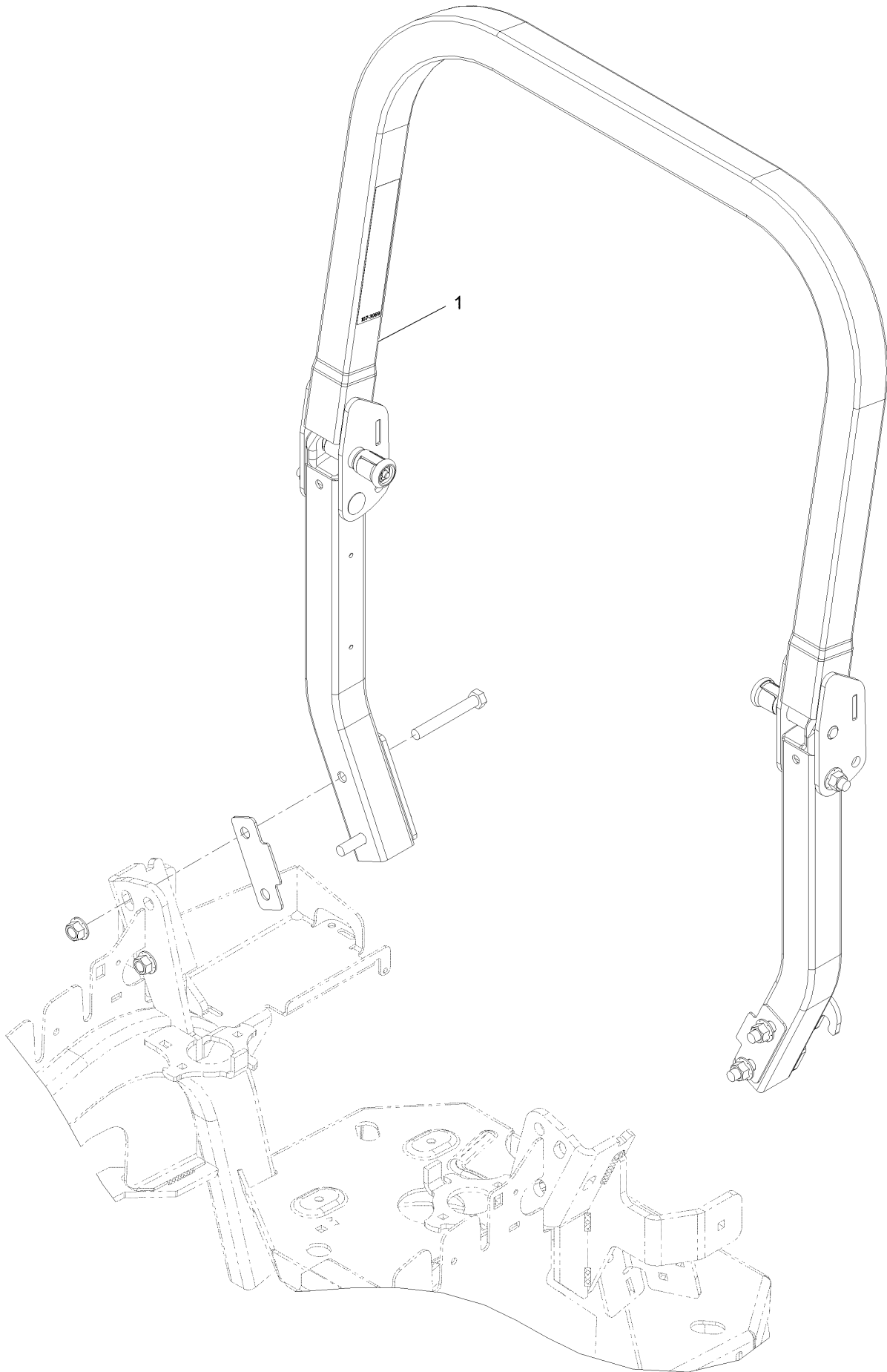

Roll-Over Protection System (continued)

| <i>Ref.</i> | <i>Part Number</i> | <i>Qty.</i> | <i>Description</i> |
|-------------|--------------------|-------------|-------------------------|
| 1 | 116-0230 | 1 | ASM,ROPS Service Exmark |

Roll Over Protection System (cont.)

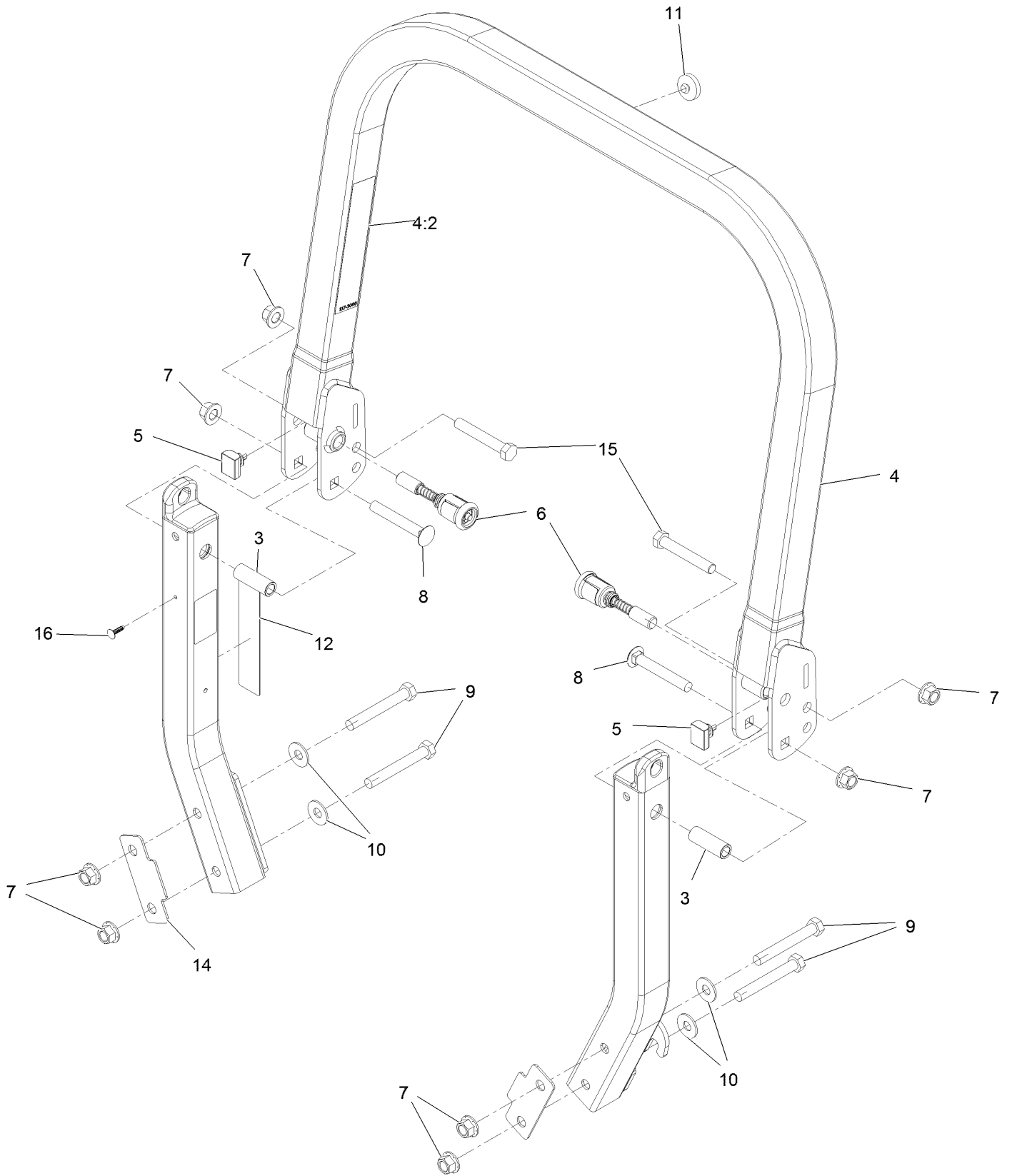

Roll Over Protection System (cont.) (continued)

| <i>Ref.</i> | <i>Part Number</i> | <i>Qty.</i> | <i>Description</i> | <i>Ref.</i> | <i>Part Number</i> | <i>Qty.</i> | <i>Description</i> |
|-------------|--------------------|-------------|------------------------------|-------------|--------------------|-------------|--------------------------|
| 3 | 109-6653 | 2 | Spacer | 9 | 325-35 | 4 | Screw-HH |
| 4 | 116-0019 | 1 | Upper ROPS ASM | 10 | 109-9505 | 4 | Washer, Spring Disc 1/2 |
| 4:2 | 107-3069 | 1 | Decal-Warning | 11 | 109-9233 | 1 | Bumper-Push-In, Rubber |
| 5 | 109-5337 | 2 | Bumper-ROPS | 12 | 117-0346 | 1 | Decal-Caution, Fuel Vent |
| 6 | 116-0104 | 2 | Pin-Spring | 14 | 116-0960 | 2 | Spacer |
| 7 | 99-5107 | 8 | Nut-Lock 1/2-13 | 15 | 325-13 | 2 | Screw-HH |
| 8 | 3233-10 | 2 | Bolt-Carriage 1/2-13 X 3 1/2 | 16 | 125-8067 | 1 | Plug-Plastic |

Front Caster and Fork Assembly

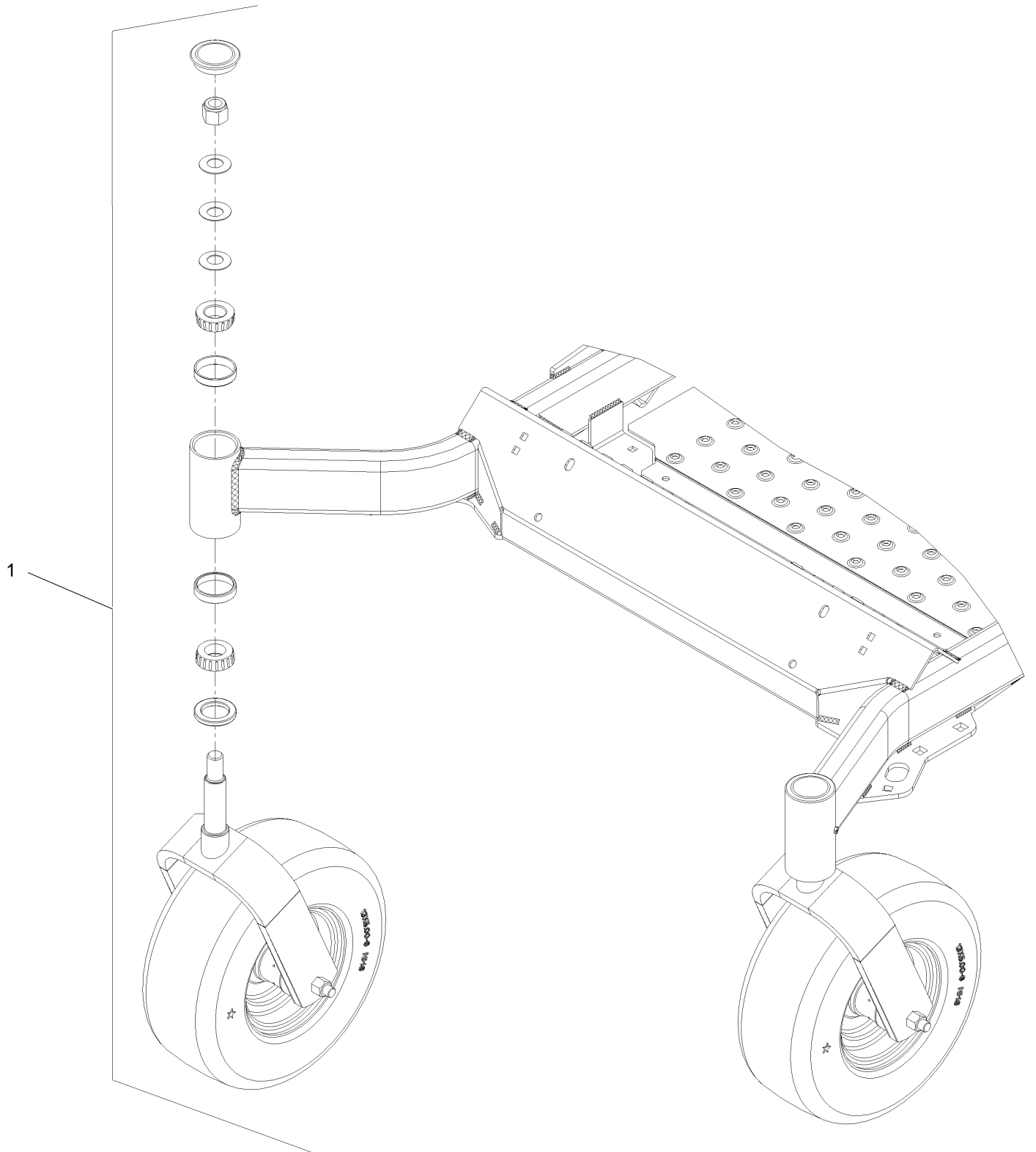

Front Caster and Fork Assembly (continued)

| <i>Ref.</i> | <i>Part Number</i> | <i>Qty.</i> | <i>Description</i> |
|-------------|--------------------|-------------|---------------------------|
| 1 | | 2 | Front Caster And Fork ASM |
| | | | ● |

● Not serviced separately

Caster Wheel and Fork Assembly

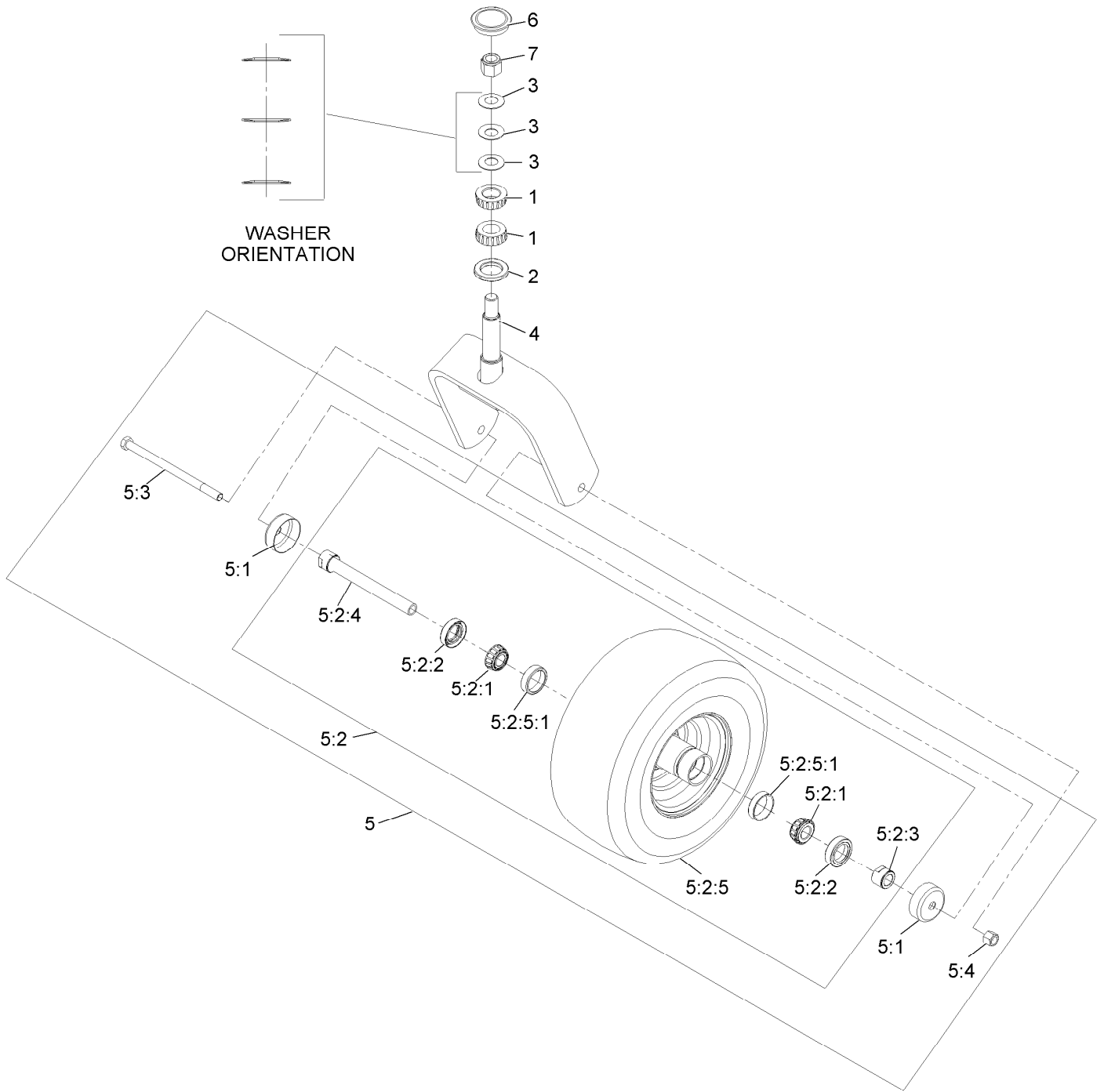

Caster Wheel and Fork Assembly (continued)

| <i>Ref.</i> | <i>Part Number</i> | <i>Qty.</i> | <i>Description</i> | <i>Ref.</i> | <i>Part Number</i> | <i>Qty.</i> | <i>Description</i> |
|-------------|--------------------|-------------|-------------------------|-------------|--------------------|-------------|----------------------|
| 1 | 1-543509 | 2 | Bearing-Roller, Tapered | 5:2:3 | 103-3051 | 1 | Spacer-Nut ■ |
| 2 | 116-5647 | 1 | Seal-Grease | 5:2:4 | 126-5361 | 1 | Axle Caster ASM |
| 3 | 1-633508 | 3 | Washer-Bellville | 5:2:5 | | 1 | Wheel And Tire ASM ● |
| 4 | 116-6707-01 | 1 | Caster | 5:2:5:1 | 1-633584 | 2 | Bearing-Cup |
| 5 | 109-9127 | 1 | Wheel & Tire ASM | 5:3 | 325-39 | 1 | Screw-HH |
| 5:1 | 103-2768 | 2 | Guard-Seal | 5:4 | 3296-23 | 1 | Nut-Lock, NI |
| 5:2 | | 1 | Wheel And Tire ASM ● | 6 | 103-4882 | 1 | Cap-Grease |
| 5:2:1 | 1-633585 | 2 | Bearing-Cone, Taper | 7 | 3296-51 | 1 | Nut-Lock, NI |
| 5:2:2 | 103-0063 | 2 | Seal-Caster | | | | |

● Not serviced separately

■ Use Pro-Lock, Nut Type (P/N 1-840022, .5ml tube) on threads.

Deck Lift Assembly

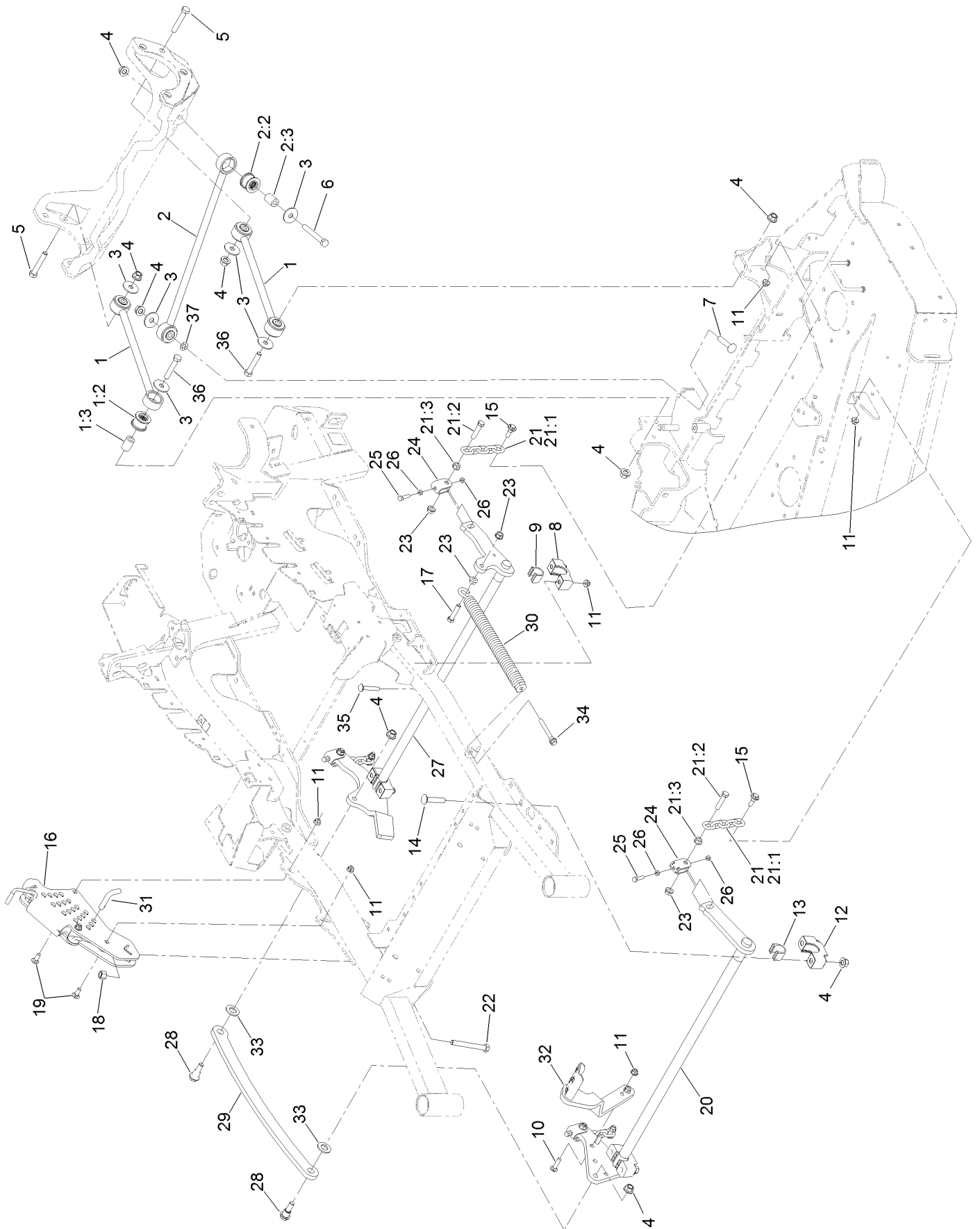

Deck Lift Assembly (continued)

| <i>Ref.</i> | <i>Part Number</i> | <i>Qty.</i> | <i>Description</i> | <i>Ref.</i> | <i>Part Number</i> | <i>Qty.</i> | <i>Description</i> |
|-------------|--------------------|-------------|---|-------------|--------------------|-------------|---------------------|
| 1 | 109-7952 | 2 | Deck Strut ASM | 17 | 109-9065 | 1 | Screw-HH |
| 1:2 | 109-5009 | 2 | Bushing-Suspension, Rubber | 18 | 3296-23 | 1 | Nut-Lock, NI |
| 1:3 | 109-5010 | 2 | Spacer | 19 | 3231-2 | 2 | Bolt-CARR |
| 2 | 109-5013 | 1 | Panhard Rod ASM | 20 | 126-2475-03 | 1 | Decklift-Front |
| 2:2 | 109-5009 | 2 | Bushing-Suspension, Rubber | 21 | 116-0756 | 4 | Deck Lift Chain ASM |
| 2:3 | 109-5010 | 2 | Spacer | 21:1 | 1-633447 | 1 | Chain-Lift, Deck |
| 3 | 86-1990 | 6 | Washer-Thrust | 21:2 | 109-9065 | 1 | Screw-HH |
| 4 | 99-5107 | 12 | Nut-Lock | 21:3 | 32128-37 | 1 | Nut-HF |
| 5 | 325-12 | 2 | Screw-HH | 22 | 116-0559 | 1 | Bolt-TAP |
| 6 | 325-17 | 1 | Screw-HH | 23 | 32128-37 | 6 | Nut-HF |
| 7 | 3233-34 | 1 | Screw-CARR | 24 | 109-9066 | 4 | Yoke-Adjust, Deck |
| 8 | 127-0553 | 2 | Support-Bearing, Cross Shaft (Rear) | 25 | 322-47 | 4 | Screw-HH |
| 9 | 109-7173 | 2 | Bearing-Cross Shaft, Rear | 26 | 3218-2 | 8 | Nut-Hex Jam |
| 10 | 3231-4 | 2 | Screw-CARR | 27 | 116-0459-03 | 1 | Lift-Deck, Rear |
| 11 | 104-8301 | 12 | Nut-HF, NI | 28 | 116-0780 | 2 | Screw-Shoulder, HHF |
| 12 | 109-9409 | 2 | Support-Bearing, Cross Shaft (Front) | 29 | 116-0797-03 | 1 | Link-Lift, Deck |
| 13 | 109-9410 | 2 | Bearing-Cross Shaft, Front | 30 | 116-0000 | 1 | Spring-Extension |
| 14 | 116-1700 | 4 | Bolt-CARR | 31 | 116-5584 | 1 | Pin-HOC |
| 15 | 109-9840 | 4 | Screw-Shoulder, HHF | 32 | 116-1919-01 | 1 | Lever-Foot |
| 16 | 109-7438 | 1 | HOC ASM | 33 | 3256-28 | 2 | Washer-Flat |
| | | | | 34 | 92-7674 | 1 | Bolt-Shoulder |
| | | | | 35 | 3231-7 | 4 | Screw-CARR |
| | | | | 36 | 325-11 | 2 | Screw-HH |
| | | | | 37 | 126-2916 | 1 | Nut-Push |

Height-of-Cut Assembly No. 109-7438

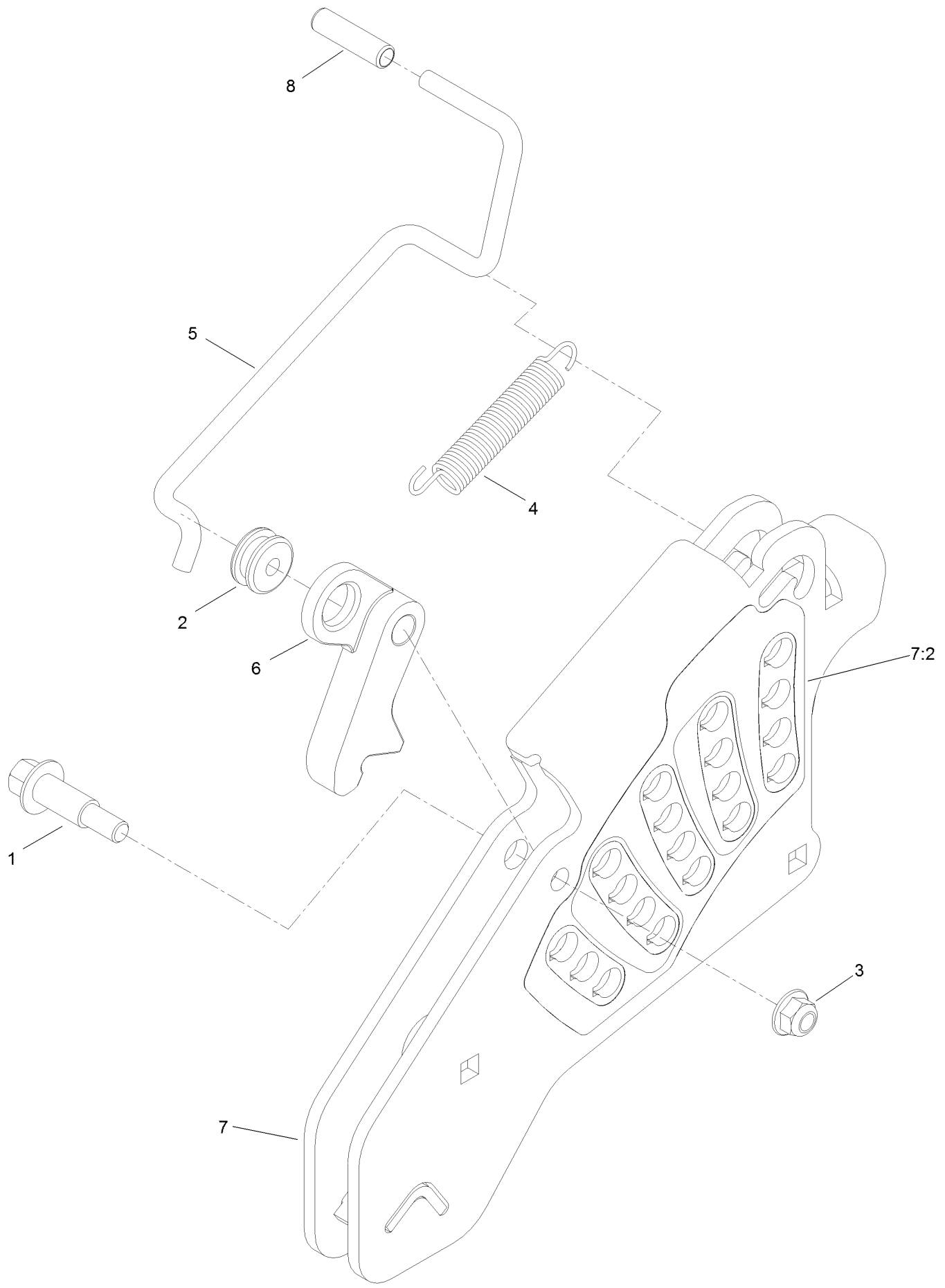

Height-of-Cut Assembly No. 109-7438 (continued)

| <i>Ref.</i> | <i>Part Number</i> | <i>Qty.</i> | <i>Description</i> | <i>Ref.</i> | <i>Part Number</i> | <i>Qty.</i> | <i>Description</i> |
|-------------|--------------------|-------------|---------------------|-------------|--------------------|-------------|---------------------|
| 1 | 62-1330 | 1 | Bolt-Shoulder | 6 | 116-0118 | 1 | Pawl-Transport, HOC |
| 2 | 109-7130 | 1 | Grommet | 7 | 109-7335 | 1 | HOC Plate ASM |
| 3 | 104-8301 | 1 | Nut-HF, NI | 7:2 | 126-4398 | 1 | Decal-HOC |
| 4 | 109-7124 | 1 | Spring-Extension | 8 | 109-8250 | 1 | Grip-Lever |
| 5 | 109-7128 | 1 | Rod-Lock, Transport | | | | |

Controls Assembly

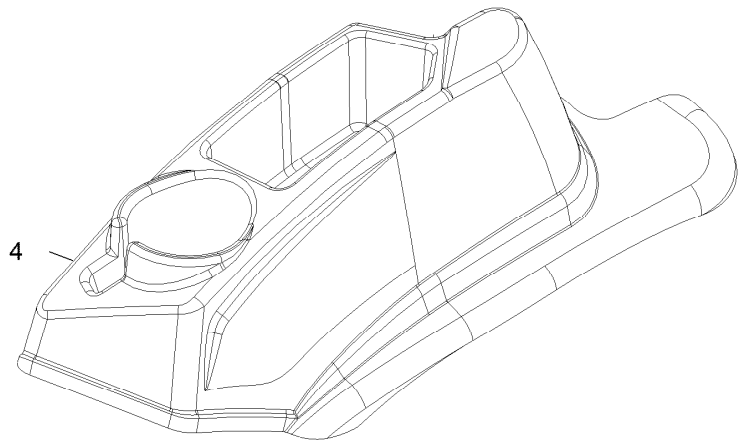
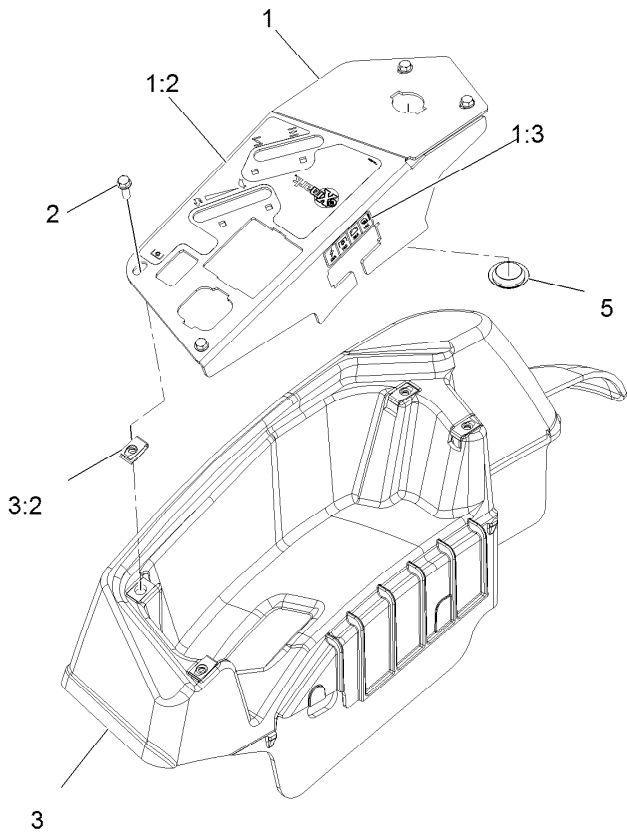

Controls Assembly (continued)

| <i>Ref.</i> | <i>Part Number</i> | <i>Qty.</i> | <i>Description</i> | <i>Ref.</i> | <i>Part Number</i> | <i>Qty.</i> | <i>Description</i> |
|-------------|--------------------|-------------|--------------------------------|-------------|--------------------|-------------|----------------------------|
| 1 | 135-3146 | 1 | ASM-Panel, Control W/Decal | 2 | 32105-15 | 4 | Screw-Machine 1/4-20 X 3/4 |
| 1:2 | 116-8724 | 1 | Decal-Control Panel Non-EFI | 3 | 116-1278 | 1 | Console,RH As ASM |
| 1:3 | 114-4466 | 1 | Decal-Fuses | 3:2 | 107069 | 4 | Nut-Retainer-Panel 1/4-20 |
| | | | | 4 | 109-9457 | 1 | Console, LH As |
| | | | | 5 | 116-1875 | 1 | Plug-Plastic |

Motion Control Assembly

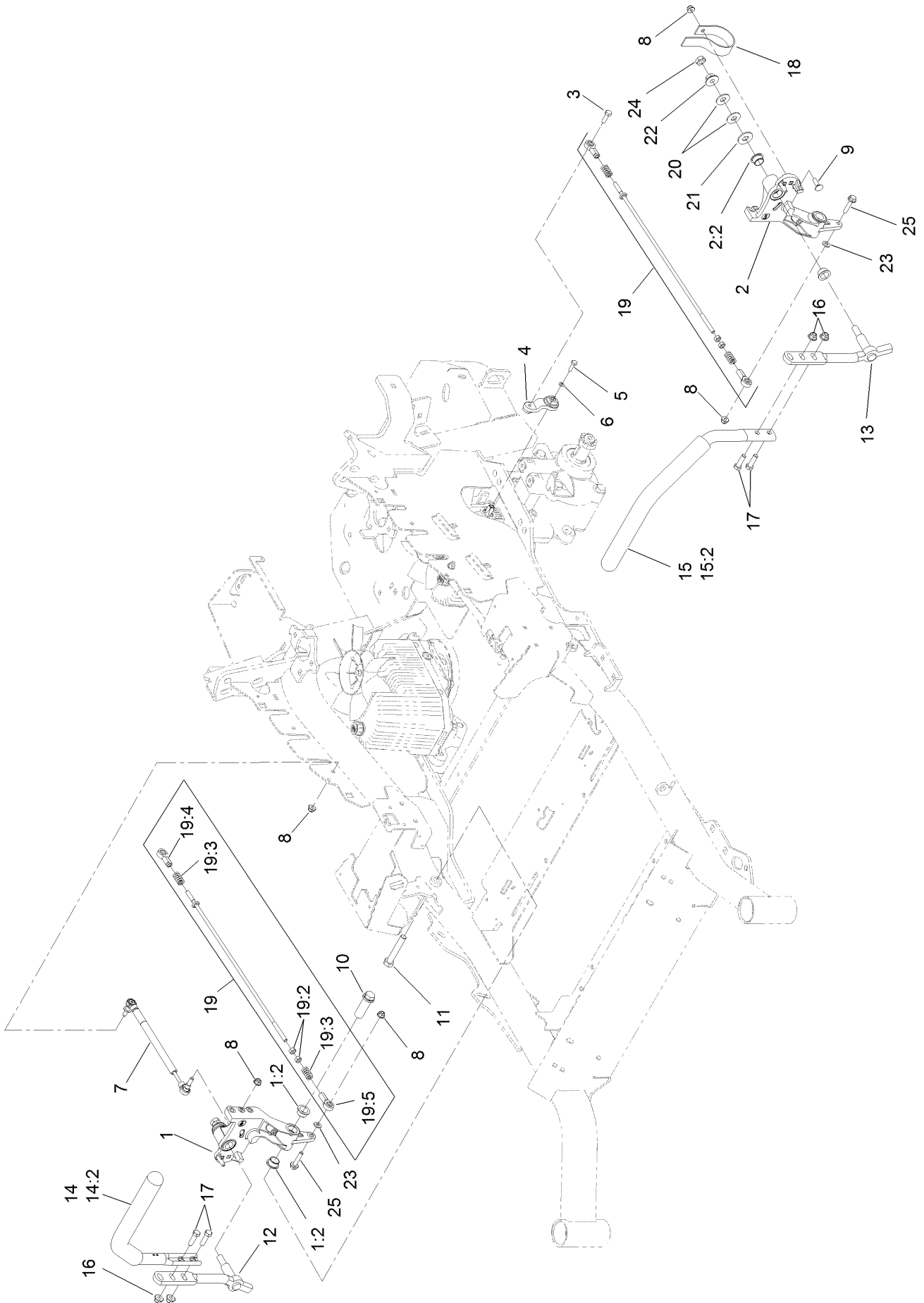

Motion Control Assembly (continued)

| <i>Ref.</i> | <i>Part Number</i> | <i>Qty.</i> | <i>Description</i> | <i>Ref.</i> | <i>Part Number</i> | <i>Qty.</i> | <i>Description</i> |
|-------------|--------------------|-------------|-----------------------------------|-------------|--------------------|-------------|------------------------|
| 1 | 116-0880 | 1 | RH Motion Control And Bushing ASM | 14 | 135-4371 | 1 | RH Handle ASM |
| 1:2 | 109-8054 | 4 | Bushing-Flange | 14:2 | 109-5668 | 1 | Grip-Lever, Control |
| 2 | 116-0881 | 1 | LH Motion Control And Bushing ASM | 15 | 135-4373 | 1 | LH Handle ASM |
| 2:2 | 109-8054 | 4 | Bushing-Flange | 15:2 | 109-5668 | 1 | Grip-Lever, Control |
| 3 | 116-0648 | 2 | Screw-HH, Thread Locking ● | 16 | 104-8301 | 4 | Nut-HF, NI |
| 4 | 109-4581 | 2 | Arm-Control, Pump | 17 | 323-7 | 4 | Screw-HH |
| 5 | 9080046 | 2 | Screw-HH ● | 18 | 109-5575 | 2 | Spring-Leaf |
| 6 | 1-303435 | 2 | Washer-Spring | 19 | 109-8106 | 2 | Front Pump Linkage ASM |
| 7 | 116-0027 | 2 | Damper-Control, Motion | 19:2 | 3219-2 | 2 | Nut-Hex |
| 8 | 104-8300 | 8 | Nut-HF, NI | 19:3 | 1-323245 | 2 | Spring-Compression |
| 9 | 3230-2 | 2 | Bolt-CARR | 19:4 | 1-633152 | 1 | Balljoint-LH |
| 10 | 109-5891 | 2 | Hub-Threaded | 19:5 | 1-543017 | 1 | Balljoint-RH |
| 11 | 325-12 | 2 | Screw-HH | 20 | 109-9505 | 4 | Washer-Spring |
| 12 | 116-0039 | 1 | Lever-Control Motion, RH | 21 | 3256-6 | 2 | Washer-Flat |
| 13 | 116-0040 | 1 | Lever-Control Motion, LH | 22 | 32128-56 | 2 | Nut-HF |
| | | | | 23 | 3256-23 | 2 | Washer-Plain |
| | | | | 24 | 3218-5 | 2 | Nut-Jam |
| | | | | 25 | 115-1794 | 2 | Screw-HHF |

● Use Pro-Lock, Nut Type (P/N 1-840022, .5ml tube) on threads.

Rear Wheel Assembly

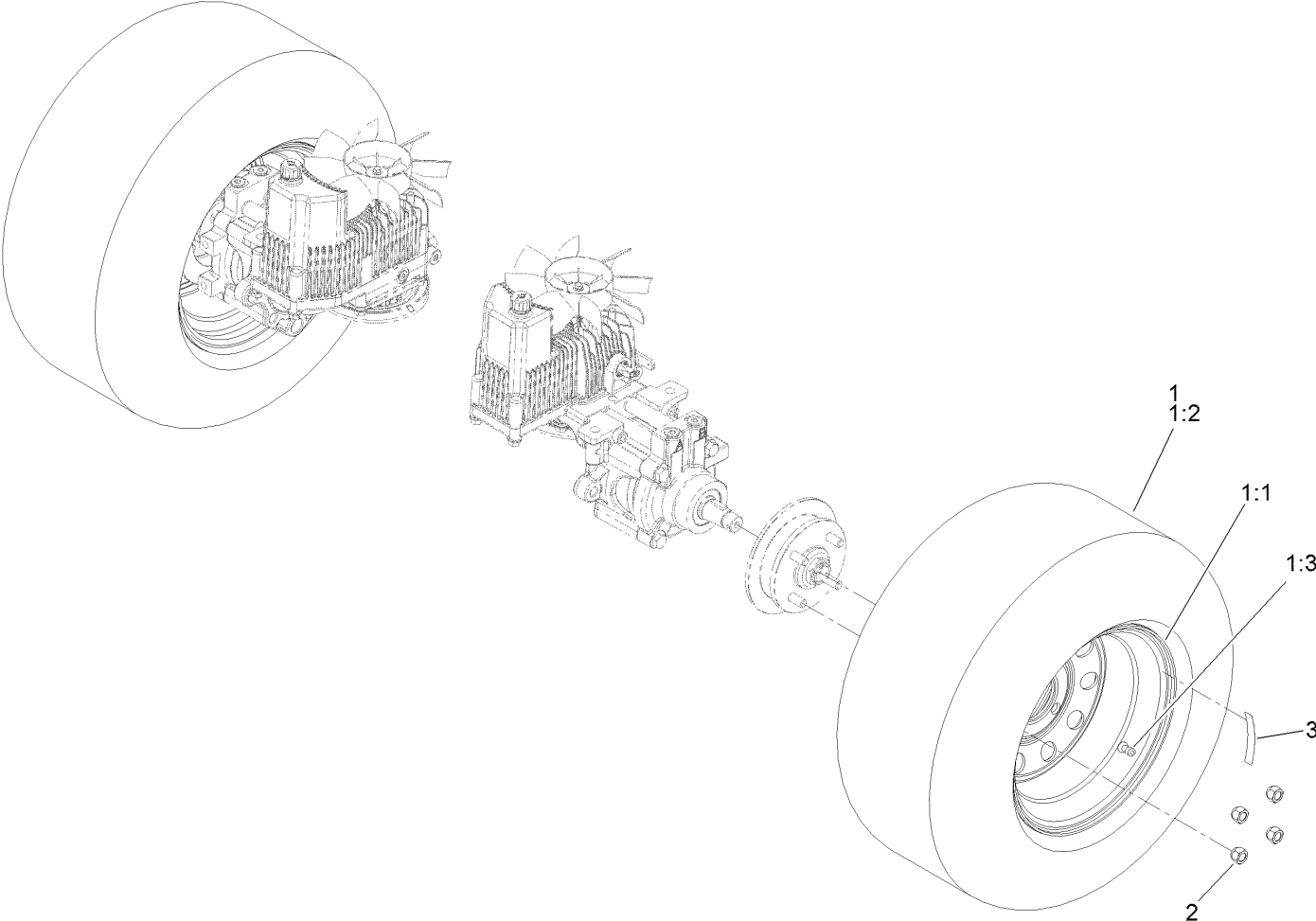

Rear Wheel Assembly (continued)

| <i>Ref.</i> | <i>Part Number</i> | <i>Qty.</i> | <i>Description</i> | <i>Ref.</i> | <i>Part Number</i> | <i>Qty.</i> | <i>Description</i> |
|-------------|--------------------|-------------|--------------------|-------------|--------------------|-------------|--------------------------------|
| 1 | 115-3588 | 2 | Wheel And Tire ASM | 2 | 242-50 | 8 | Nut-Lug |
| 1:1 | 109-2871 | 1 | Rim | 3 | 126-2055 | 2 | Decal-Torque, Wheel Hub Lug |
| 1:2 | 1-633993 | 1 | Tire | | | | |
| 1:3 | 232-27 | 1 | Stem-Valve | | | | |

Park Brake Assembly

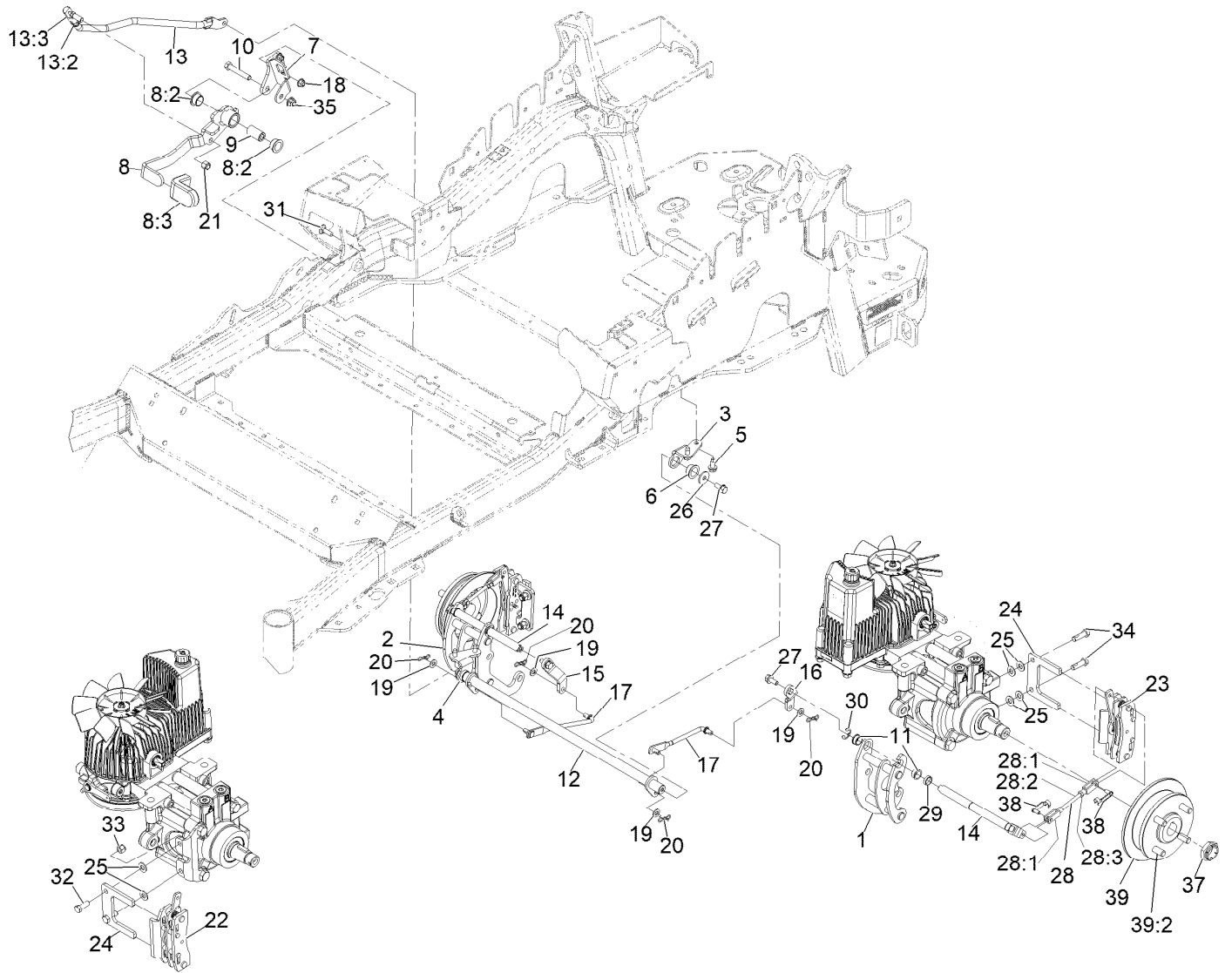

REAR VIEW OF
RIGHT HAND HYDRO

Park Brake Assembly (continued)

| <i>Ref.</i> | <i>Part Number</i> | <i>Qty.</i> | <i>Description</i> | <i>Ref.</i> | <i>Part Number</i> | <i>Qty.</i> | <i>Description</i> |
|-------------|--------------------|-------------|-------------------------------|-------------|--------------------|-------------|---------------------------|
| 1 | 126-4248 | 1 | Mount-Bellcrank, LH | 20 | 119-1415 | 4 | Pin-Cotter, Locking |
| 2 | 126-4249 | 1 | Mount-Bellcrank, RH | 21 | 3296-6 | 1 | Nut-Nyloc 3/8-24 |
| 3 | 116-9681 | 1 | Mount-Pivot, LH | 22 | 135-7440 | 1 | Caliper-Brake, RH |
| 4 | 116-9682 | 1 | Mount-Pivot, RH | 23 | 135-7441 | 1 | Caliper-Brake, LH |
| 5 | 32144-70 | 4 | Screw-HWH 5/16-18 X 3/4 Tf | 24 | 135-7828 | 2 | Plate-Mount, Brake |
| 6 | 109-8054 | 2 | Bushing-Flanged | 25 | 3256-24 | 6 | Washer-3/8 SAE |
| 7 | 116-9096-01 | 1 | Bracket-Mount | 26 | 115-7109 | 2 | Washer-Flat |
| 8 | 135-7565 | 1 | Brake Lever ASM | 27 | 98-9940 | 4 | Screw-HHF |
| 8:2 | 109-8054 | 2 | Bushing-Flanged | 28 | 126-7587 | 2 | Rear Linkage ASM |
| 8:3 | 132-4749 | 1 | Grip-Lever | 28:1 | 126-7588 | 2 | Yoke |
| 9 | 116-9117 | 1 | Pivot-Handle, Brake | 28:2 | 116-9069 | 1 | Linkage, Rear |
| 10 | 323-11 | 1 | Screw-HH 3/8-16 X 2 1/4 | 28:3 | 3220-1 | 1 | Nut-Jam 1/4-28 |
| 11 | 126-6199 | 4 | Bushing | 29 | 126-6200 | 2 | Spacer |
| 12 | 135-7800 | 1 | Shaft-Cross | 30 | 32120-19 | 2 | E-Ring |
| 13 | 135-7805 | 1 | ASM, Front Linkage | 31 | 3230-2 | 2 | Bolt-Carriage 5/16-18 X 1 |
| 13:2 | 94-7572 | 1 | End-Tie Rod, RH | 32 | 135-7915 | 2 | Screw-HH, |
| 13:3 | 3220-3 | 1 | Nut-Jam 3/8-24 | 33 | 112-0236 | 2 | Nut-Lock |
| 14 | 126-4251 | 2 | Bellcrank | 34 | 135-7890 | 2 | Screw-HH, Patch, |
| 15 | 126-3716 | 1 | Arm-Inner, RH | 35 | 104-8301 | 1 | Nut-Nyloc 3/8-16 Flg |
| 16 | 126-3715 | 1 | Arm-Inner, LH | 37 | 116-1399 | 2 | Locknut |
| 17 | 142-6328 | 2 | Mid-Link, Short | 38 | 126-6395 | 4 | Pin-Clevis, Spring |
| 18 | 104-8300 | 2 | Nut-Nyloc 5/16-18 Flg | 39 | 142-2701 | 2 | Wheel Hub ASM |
| 19 | 3256-23 | 4 | Washer-5/16 SAE | 39:2 | 116-1696 | 4 | Stud-Wheel |

Seat Assembly

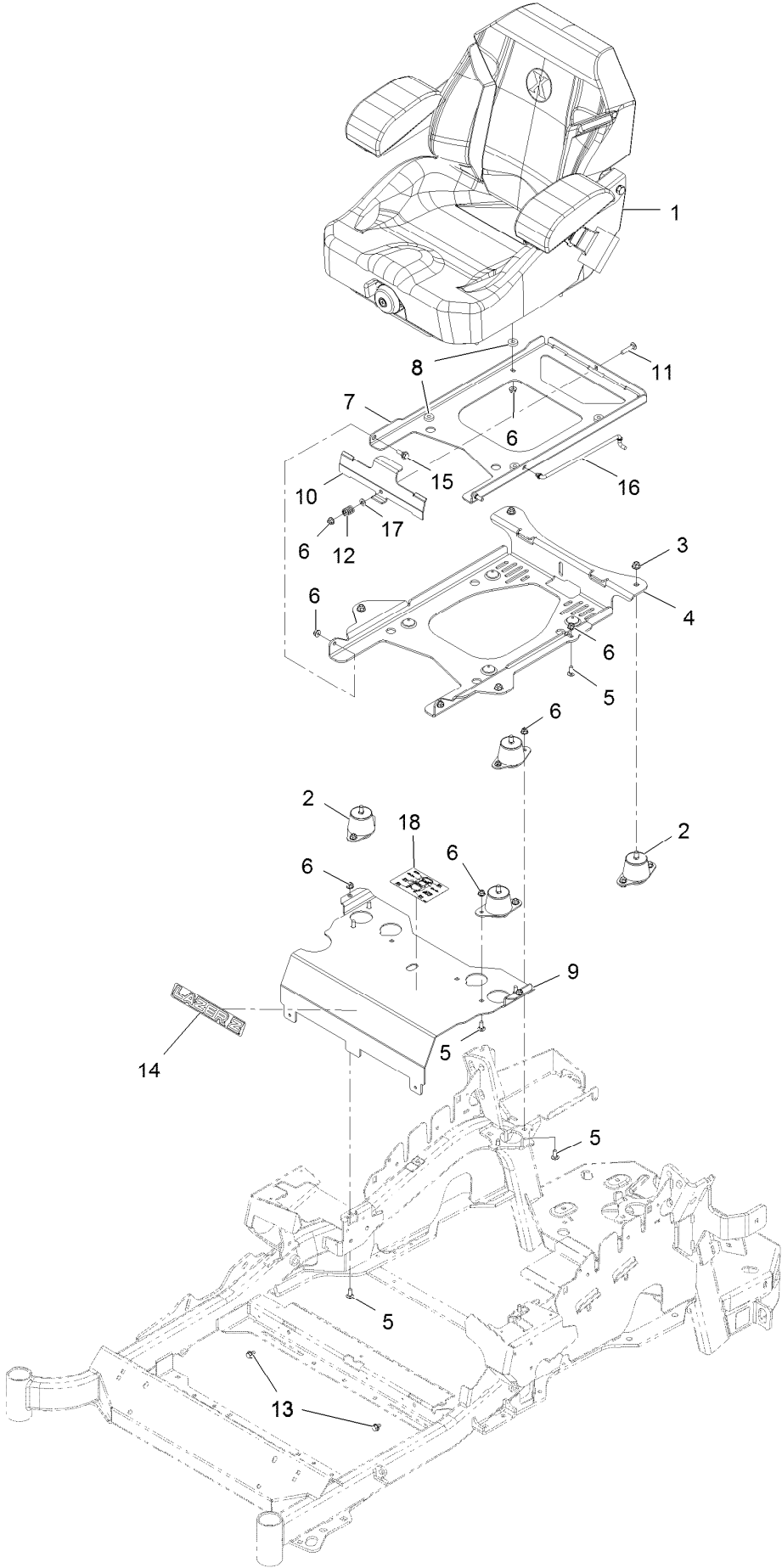

Seat Assembly (continued)

| <i>Ref.</i> | <i>Part Number</i> | <i>Qty.</i> | <i>Description</i> | <i>Ref.</i> | <i>Part Number</i> | <i>Qty.</i> | <i>Description</i> |
|-------------|--------------------|-------------|---|-------------|--------------------|-------------|----------------------------------|
| 1 | 116-8912 | 1 | Kit-Suspension Seat | 10 | 109-9881-03 | 1 | Plate-Latch, Seat |
| 2 | 109-9034 | 4 | Isolator-Seat | 11 | 3230-4 | 1 | Bolt-Carriage 5/16-18 X 1 1/2 |
| 3 | 104-8301 | 4 | Nut-Nyloc 3/8-16 Flg | 12 | 107-3017 | 1 | Spring-Compression |
| 4 | 116-3860-03 | 1 | Plate-Tilt, Seat Support | 13 | 9266934 | 2 | Screw-HWH 5/16 X 1/2 Tf |
| 5 | 3230-23 | 11 | Bolt-Carriage 5/16-18 X 3/4 Short Neck | 14 | 126-6574 | 1 | Decal, Lazer Model |
| 6 | 104-8300 | 18 | Nut-Nyloc 5/16-18 Flg | 15 | 116-1297 | 2 | Screw-Shoulder |
| 7 | 116-3859-03 | 1 | Plate-Frame, Seat | 16 | 116-0070 | 1 | Rod-Prop |
| 8 | 26-4840 | 4 | Spacer-Pin, Mounting | 17 | 3256-23 | 1 | Washer-5/16 SAE |
| 9 | 116-2130-03 | 1 | Panel-Front, Seat Mount | 18 | 114-4465 | 1 | Decal-Service Aid |

Seat Assembly (cont.)

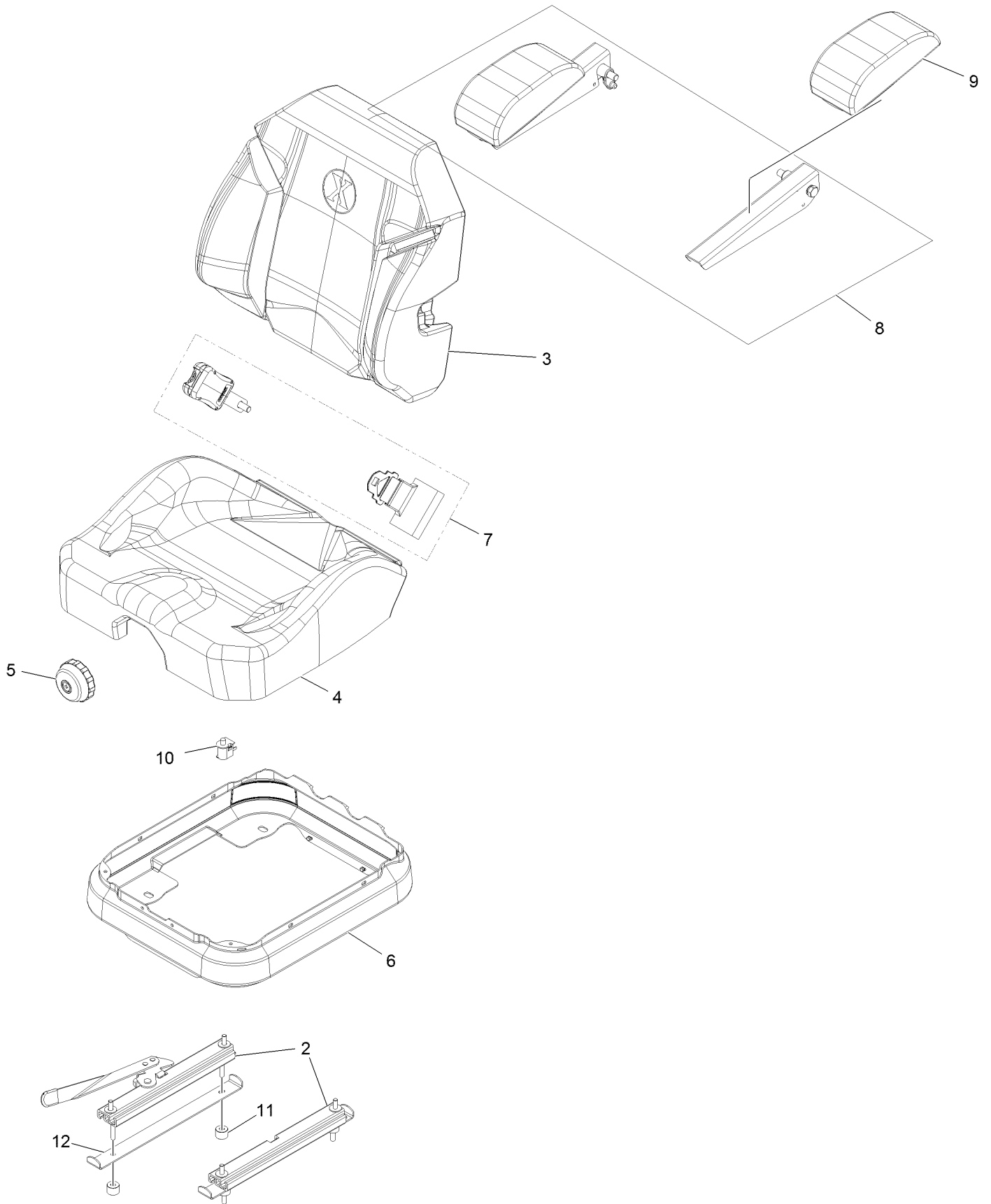

Seat Assembly (cont.) (continued)

| <i>Ref.</i> | <i>Part Number</i> | <i>Qty.</i> | <i>Description</i> | <i>Ref.</i> | <i>Part Number</i> | <i>Qty.</i> | <i>Description</i> |
|-------------|--------------------|-------------|------------------------------|-------------|--------------------|-------------|-----------------------|
| 2 | 116-8910 | 1 | Seat Track Set | 7 | 126-2061 | 1 | Seat Belt Service Kit |
| 3 | 116-8908 | 1 | Cover-Back 311463Vn500 | 8 | 116-8906 | 1 | Kit-Arm Rest Set |
| 4 | 116-8909 | 1 | Cover-Cushion 311464Vn500 | 9 | 116-8905 | 1 | Kit-Arm Rest Pads |
| 5 | 116-8911 | 1 | Knob-Adjuster | 10 | 82-2190 | 1 | Switch |
| 6 | 116-5659 | 1 | Cover-Suspension Bellows | 11 | 116-9329 | 4 | Spacer |
| | | | | 12 | 126-9918-03 | 2 | Stop, Seat ● |

● Used on Diesel models only

Fuel System Assembly

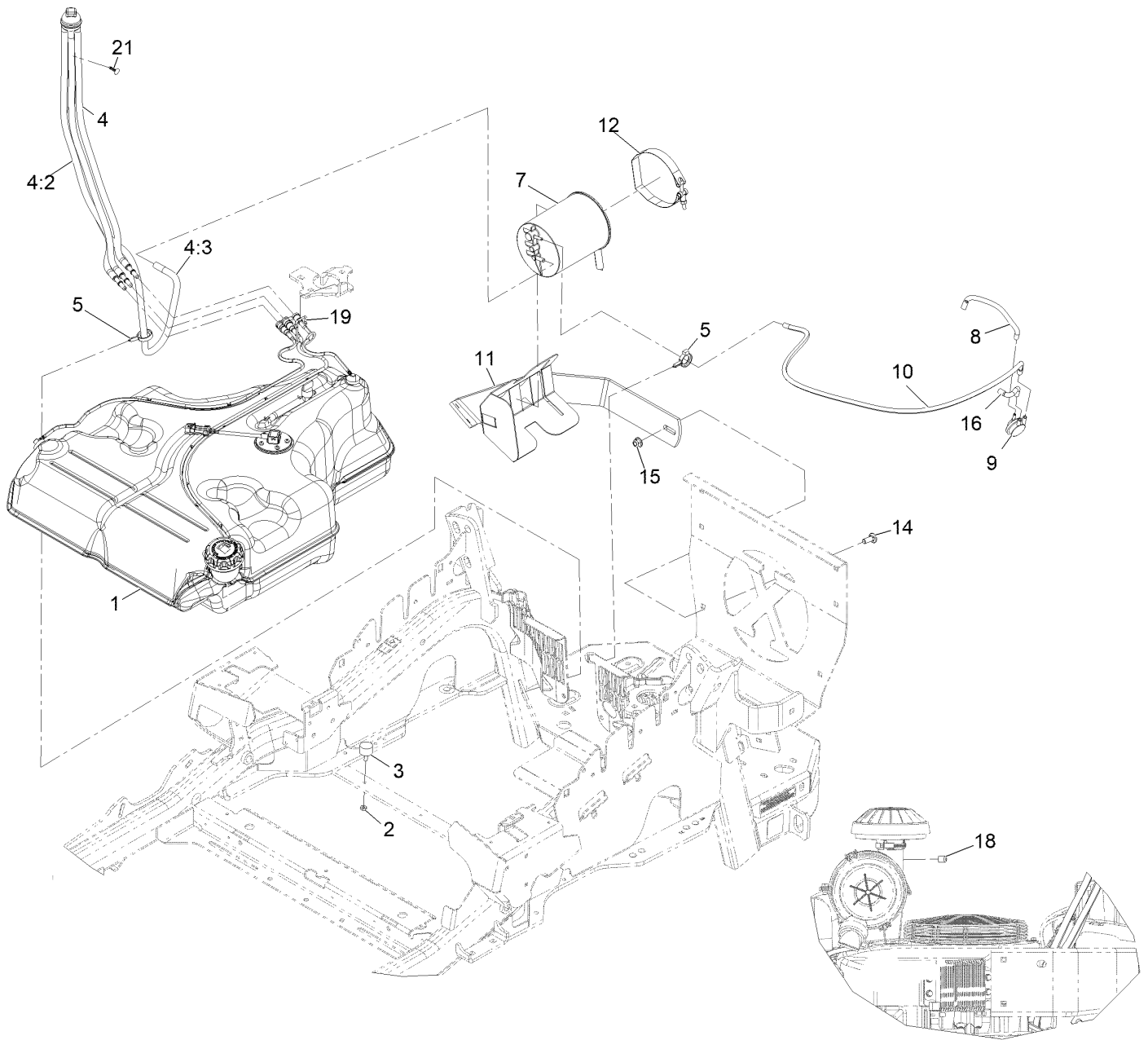

Fuel System Assembly (continued)

| <i>Ref.</i> | <i>Part Number</i> | <i>Qty.</i> | <i>Description</i> | <i>Ref.</i> | <i>Part Number</i> | <i>Qty.</i> | <i>Description</i> |
|-------------|--------------------|-------------|-------------------------|-------------|--------------------|-------------|--------------------------|
| 1 | 135-0643 | 1 | Fuel Tank ASM | 10 | 135-3417 | 1 | Hose,Vent,Formed |
| 2 | 3218-1 | 2 | Nut-Jam 1/4-20 | 11 | 116-1433-03 | 1 | Mount-Canister |
| 3 | 1-523420 | 2 | Bumper | 12 | 116-2228 | 1 | Clamp, T-Bolt |
| 4 | 127-0583 | 1 | Fuel Manifold Vent ASM | 14 | 3231-22 | 1 | Bolt-Carriage 3/8-16 X 1 |
| 4:2 | 109-0302 | 3 | Hose-Fuel Line 24" | 15 | 104-8301 | 1 | Nut-Nyloc 3/8-16 Flg |
| 4:3 | 108-5376 | 1 | Hose-Fuel | 16 | 119-8502 | 1 | Hose-Vent, Formed |
| 5 | 105-1853 | 2 | Clamp-Hose | 18 | 116-4464 | 1 | Plug-Port |
| 7 | 116-1442 | 1 | Canister-Carbon, 1200Cc | 19 | 116-6005 | 1 | Retainer-Line, Vapor |
| 8 | 135-3415 | 1 | Hose-Vent,Formed | 21 | 125-8067 | 1 | Plug-Plastic |
| 9 | 116-2232 | 1 | Valve-Control, Vacuum | | | | |

Fuel Tank Assembly

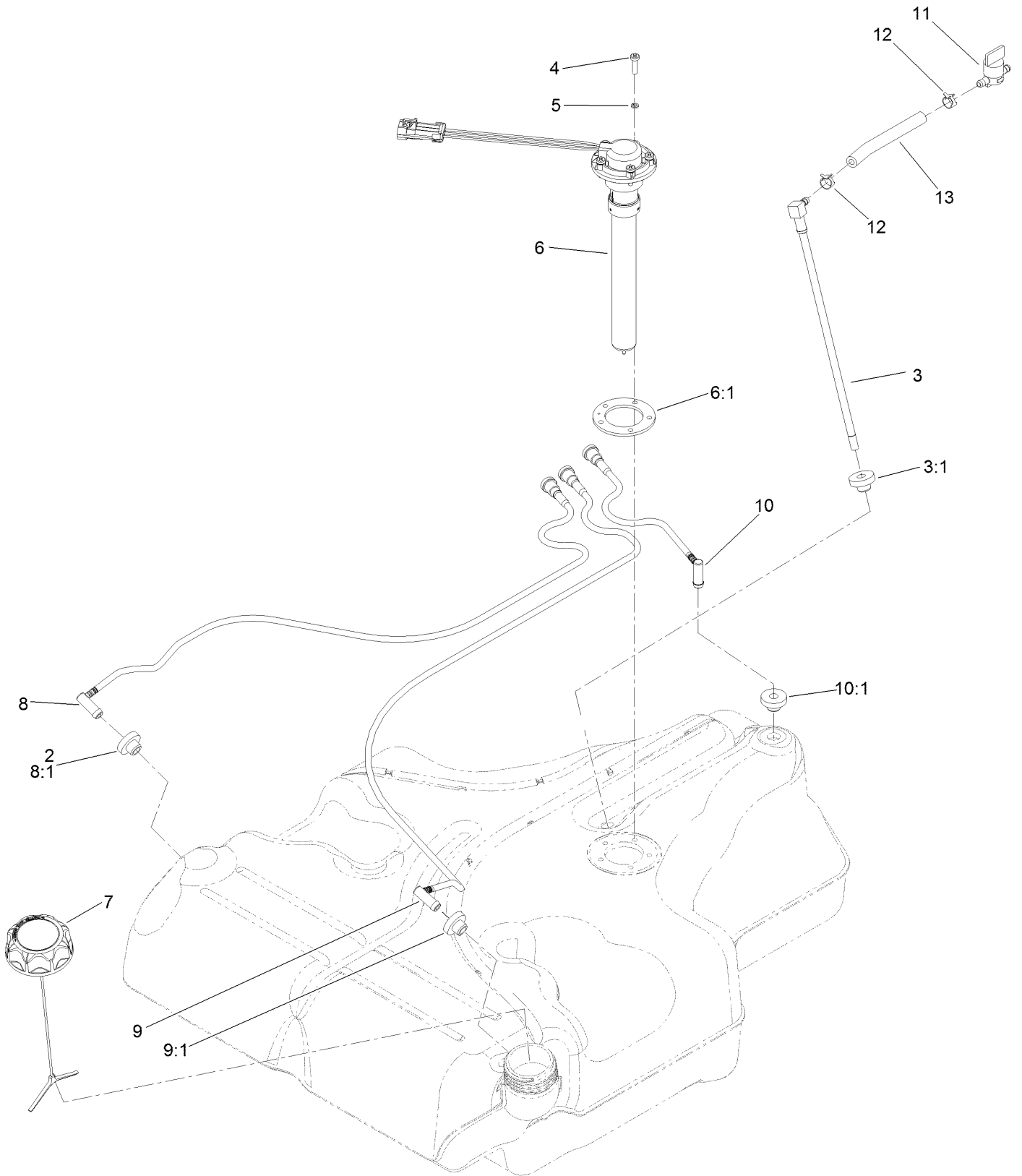

Fuel Tank Assembly (continued)

| <i>Ref.</i> | <i>Part Number</i> | <i>Qty.</i> | <i>Description</i> | <i>Ref.</i> | <i>Part Number</i> | <i>Qty.</i> | <i>Description</i> |
|-------------|--------------------|-------------|---------------------------------|-------------|--------------------|-------------|-----------------------------------|
| 2 | 46-6560 | 4 | Bushing | 8:1 | 46-6560 | 1 | Bushing |
| 3 | 116-2459 | 1 | Fuel Line Kit (With Grommet) | 9 | 116-2461 | 1 | LH Vent Line Kit (With Grommet) |
| 3:1 | 46-6560 | 1 | Bushing | 9:1 | 46-6560 | 1 | Bushing |
| 4 | 3290-500 | 5 | Screw-PPH | 10 | 116-2462 | 1 | Rear Vent Line Kit (With Grommet) |
| 5 | 3253-17 | 5 | Washer-Lock | 10:1 | 46-6560 | 1 | Bushing |
| 6 | 126-3913 | 1 | Float-Sender, Fuel | 11 | 1-603770 | 1 | Valve-Fuel |
| 6:1 | 126-3950 | 1 | Gasket-Sender | 12 | 2412-98 | 2 | Clamp-Hose |
| 7 | 126-1789 | 1 | Cap-Fuel, Ratcheting | 13 | 109-0650 | 1 | Hose-Fuel |
| 8 | 116-2460 | 1 | RH Vent Line Kit (With Grommet) | | | | |

Engine Assembly

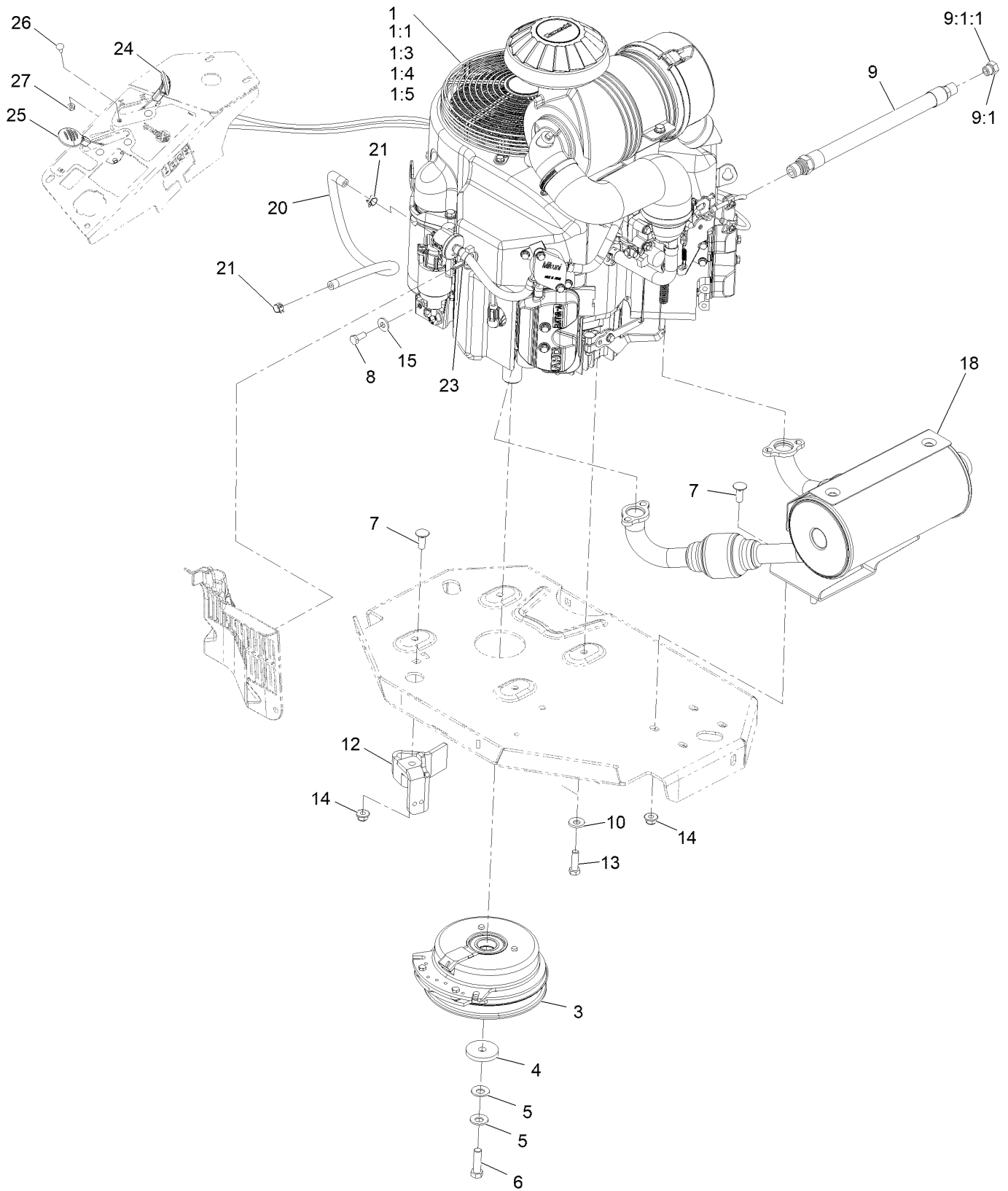

Engine Assembly (continued)

| <i>Ref.</i> | <i>Part Number</i> | <i>Qty.</i> | <i>Description</i> | <i>Ref.</i> | <i>Part Number</i> | <i>Qty.</i> | <i>Description</i> |
|-------------|--------------------|-------------|---|-------------|--------------------|-------------|----------------------------|
| 1 | | 1 | Engine-Kawasaki Fx801V ▲ ◆ | 9:1 | 353-508 | 1 | Plug-W/O-Ring ● |
| 1:1 | | 1 | Kawasaki 49065-2078 Engine Oil Filter ▲◆ | 9:1:1 | 237-42 | 1 | O-Ring |
| 1:3 | | 1 | Kawasaki 49019-0031 Fuel Filter ▲◆ | 10 | 98-5975 | 4 | Washer-Spring Disc 3/8 |
| 1:4 | | 1 | Kawasaki 11013-7039 Safety Filter ▲◆ | 12 | 116-2612-01 | 1 | Clutch-Anchor |
| 1:5 | | 1 | Kawasaki 11013-7038 Air Filter ▲◆ | 13 | 323-7 | 4 | Screw-HH 3/8-16 X 1 1/4 |
| 3 | 116-1620 | 1 | Clutch Kit | 14 | 104-8301 | 5 | Nut-Nyloc 3/8-16 Flg |
| 4 | 109-6919 | 1 | Washer-Clutch | 15 | 1-303334 | 1 | Washer-Spring Disc 5/16 |
| 5 | 1-603610 | 2 | Washer-Spring Disc 7/16 | 18 | 135-7562 | 1 | Kit, Muffler |
| 6 | 109-9761 | 1 | Screw-HH 7/16-20 X 1 1/2 W/Loctite □ | 20 | 109-0298 | 1 | Line-Fuel |
| 7 | 3231-22 | 5 | Bolt-Carriage 3/8-16 X 1 | 21 | 2412-98 | 2 | Clamp-Hose |
| 8 | 33114-020 | 1 | Screw-HH M8-1.25 X 20Mm | 23 | 105-1853 | 2 | Clamp-Hose |
| 9 | 116-4924 | 1 | Asm-Hose Oil Drain W/Plug ■ | 24 | 109-8167 | 1 | ASM, Choke Cable |
| | | | | 25 | 116-1972 | 1 | ASM,Throttle Cable |
| | | | | 26 | 1-807513 | 4 | Bolt-Carriage #10-24 X 1/2 |
| | | | | 27 | 3296-2 | 4 | Nut-Nyloc #10-24 |

● Torque to 24-26 ft-lb

▲ Not serviced separately

□ Use Pro-Lock, Nut Type (P/N 1-840022, .5ml tube) on threads.

■ Torque to 23-29 ft-lb

◆ Obtain parts from www.kawpower.com

Hydraulic Assembly

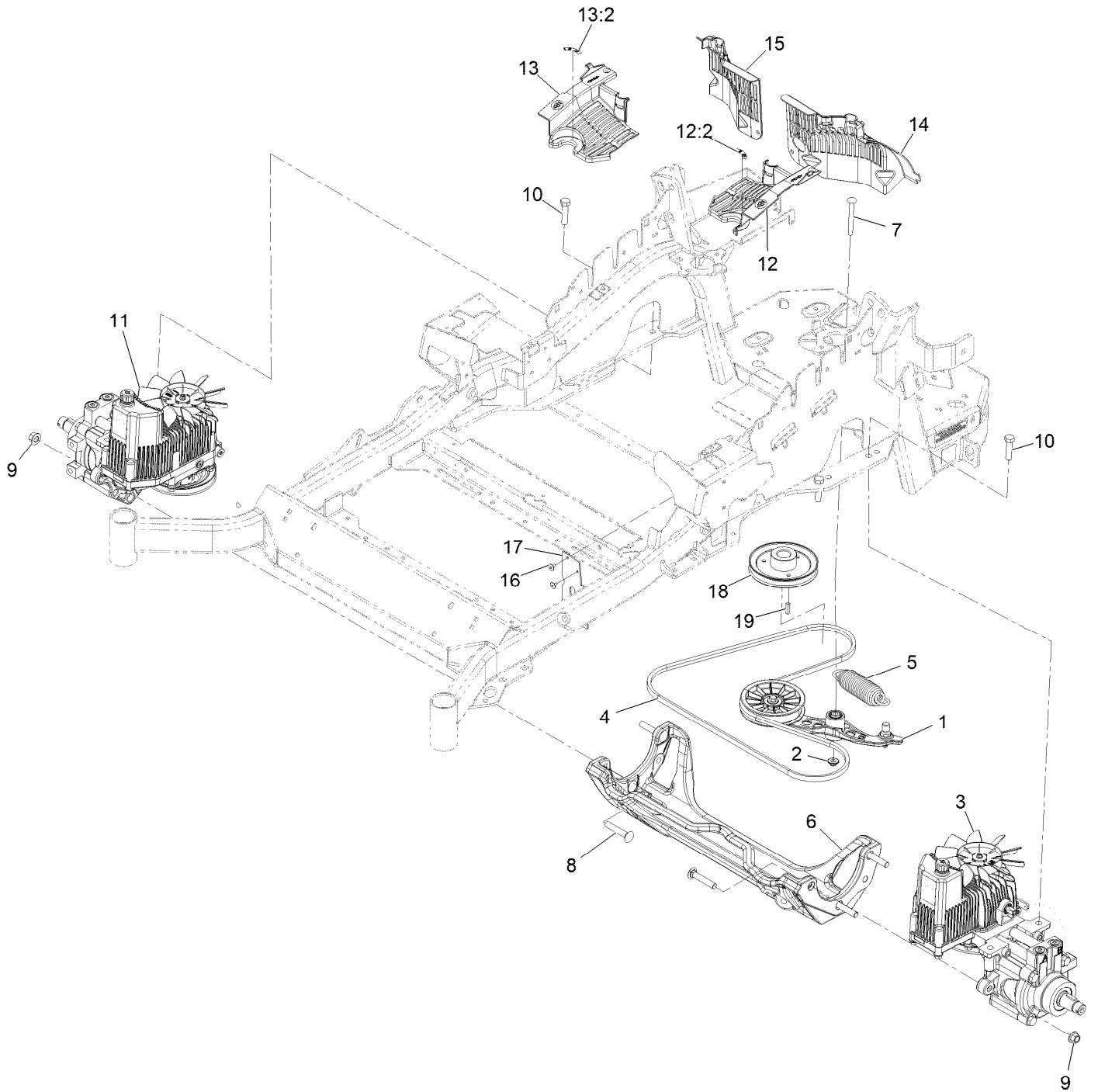

Hydraulic Assembly (continued)

| <i>Ref.</i> | <i>Part Number</i> | <i>Qty.</i> | <i>Description</i> | <i>Ref.</i> | <i>Part Number</i> | <i>Qty.</i> | <i>Description</i> |
|-------------|--------------------|-------------|-------------------------|-------------|--------------------|-------------|---------------------------|
| 1 | 116-1255 | 1 | Pump Idler ASM | 13 | 116-0171 | 1 | RH Hydro Guard ASM |
| 2 | 109-6658 | 1 | Nut-Nyloc 3/8-16 Flg | 13:2 | 116-8726 | 1 | Decal-Oil, Hydro |
| 3 | 135-7903 | 1 | Hydro-LH | 14 | 109-9057 | 1 | Guard-Hydro, Rear (LH) |
| 4 | 126-9835 | 1 | Belt-V | 15 | 109-9058 | 1 | Guard-Hydro, Rear (RH) |
| 5 | 116-6317 | 1 | Spring-Extension | 16 | 1-803035 | 2 | Rivet 3/16 X 1/4 |
| 6 | 116-7558 | 1 | Cradle-Hydro | 17 | 116-2362 | 1 | Deflector-Air Flow |
| 7 | 116-1502 | 1 | Bolt-Shoulder, Carriage | 18 | 109-9905 | 1 | Sheave |
| 8 | 126-0095 | 6 | Screw-CARR | 19 | 1-807259 | 1 | Key-Machine 1/4 X 1/4 X 1 |
| 9 | 99-5107 | 6 | Nut-Lock | 99 | 109-9828 | 1 | Oil-HYD, (Quart) ● |
| 10 | 325-8 | 4 | Screw-HH | 99 | 116-0164 | 1 | Filter-Hydro ● |
| 11 | 135-7904 | 1 | Hydro-RH | 99 | 116-1218 | 1 | Oil-HYD, 1 Gallon ● |
| 12 | 116-0170 | 1 | LH Hydro Guard ASM | 99 | 126-8103 | 1 | Kit, Hydro Service ● |
| 12:2 | 116-8726 | 1 | Decal-Oil, Hydro | | | | |

● Not illustrated

LH Hydro Assembly No. 135-7903

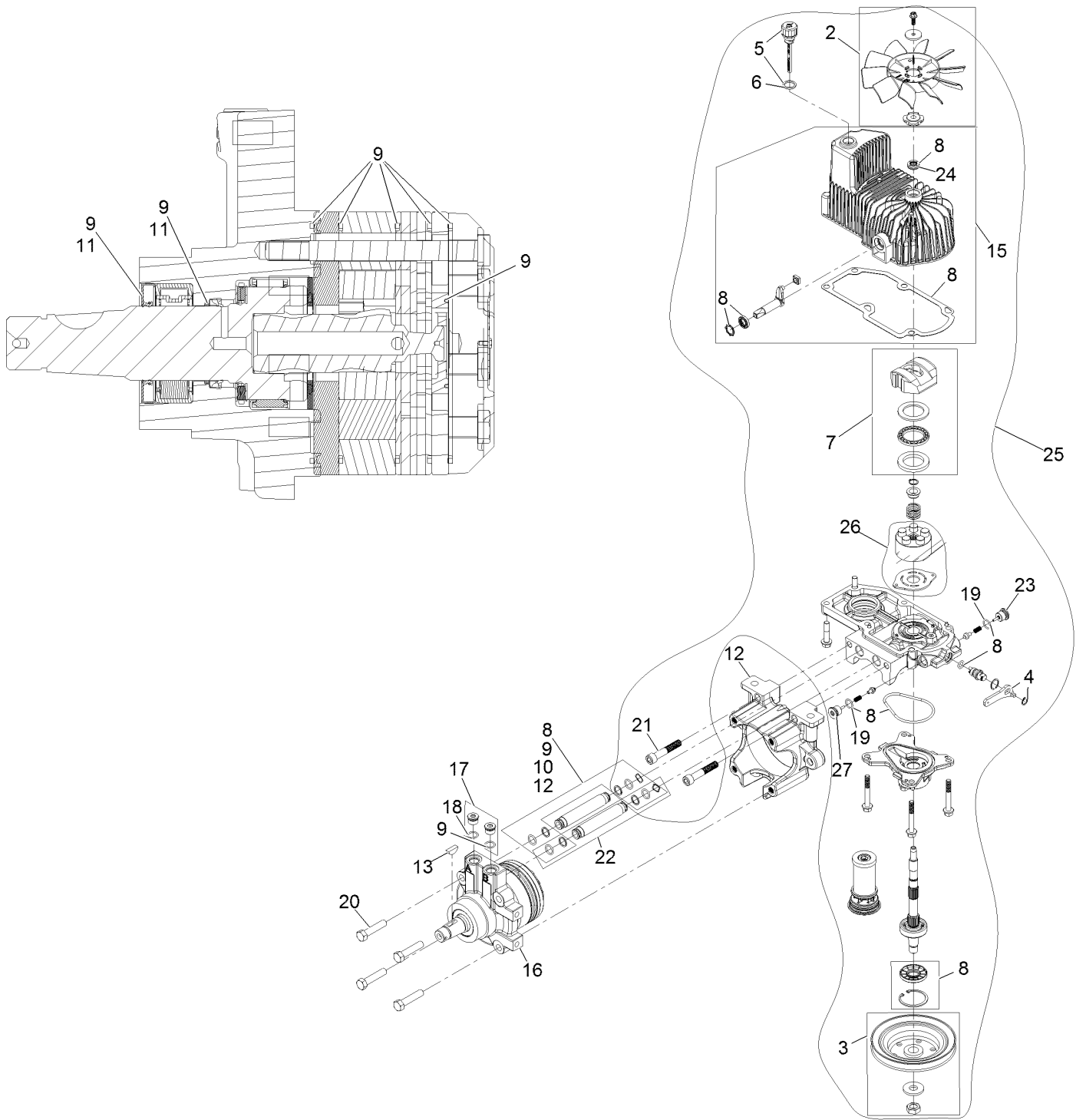

LH Hydro Assembly No. 135-7903 (continued)

| <i>Ref.</i> | <i>Part Number</i> | <i>Qty.</i> | <i>Description</i> | <i>Ref.</i> | <i>Part Number</i> | <i>Qty.</i> | <i>Description</i> |
|-------------|--------------------|-------------|-----------------------|-------------|--------------------|-------------|--------------------------------------|
| 2 | 142-3603 | 1 | Kit, 7.8 In Fan | 17 | 116-7901 | 1 | Magnetic Plugs Service Kit |
| 3 | 116-0234 | 1 | Pulley Kit | 18 | 76-1900 | 2 | O-Ring |
| 4 | 116-0235 | 1 | Handle | 19 | 116-8662 | 2 | O-Ring-Valve, Check |
| 5 | 116-0236 | 1 | Dipstick | 20 | 116-8974 | 4 | Screw-HH 1/2-20 X 2 1/4 |
| 6 | 116-0237 | 1 | Gasket | 21 | 116-8975 | 2 | Screw-HSH 1/2-20 X 2 3/4 |
| 7 | 116-1367 | 1 | Swash Block Kit | 22 | 116-9922 | 2 | Hydraulic Tube Kit |
| 8 | 142-3604 | 1 | Kit, Pump Seal | 23 | 126-7466 | 1 | Valve-Shock |
| 9 | 116-1369 | 1 | Motor Seal Kit | 24 | 126-7711 | 1 | Seal-Drive, Fan |
| 10 | 116-1370 | 1 | Tube Seal Kit | 25 | 142-3609 | 1 | Kit, Pump Section 12Cc LH |
| 11 | 116-1371 | 1 | Output Shaft Seal Kit | 26 | 142-4500 | 1 | Kit - 12Cc Port Plate, Rotate Grp |
| 12 | 116-5469 | 1 | Cup-Nose | 27 | 142-4459 | 1 | Shock Valve Orificed 3800 |
| 13 | 3257-42 | 1 | Key-Woodruff 5/16 X 1 | 99 | 116-1373 | 1 | Flow Test Kit ● |
| 15 | 142-4460 | 1 | Kit, Housing-Hydro LH | 99 | 116-4245 | 1 | Puller-Pulley ● |
| 16 | 116-8915 | 1 | Motor-Hydraulic | | | | |

● Not illustrated

RH Hydro Assembly No. 135-7904

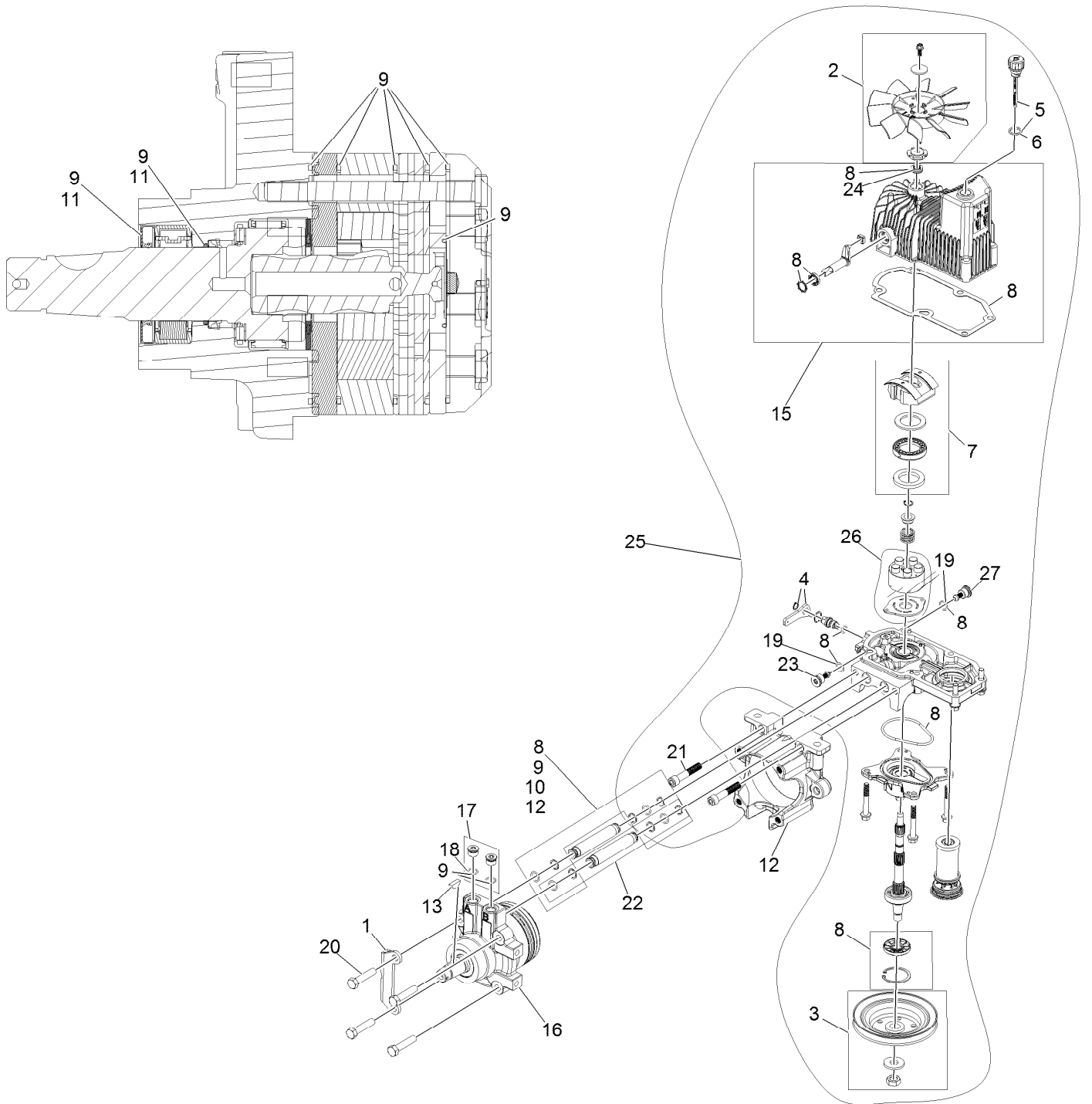

RH Hydro Assembly No. 135-7904 (continued)

| <i>Ref.</i> | <i>Part Number</i> | <i>Qty.</i> | <i>Description</i> | <i>Ref.</i> | <i>Part Number</i> | <i>Qty.</i> | <i>Description</i> |
|-------------|--------------------|-------------|--------------------------|-------------|--------------------|-------------|-----------------------------------|
| 1 | 135-7827 | 1 | Plate, Horse Shoe Mount | 17 | 116-7901 | 1 | Magnetic Plugs Service Kit |
| 2 | 142-3603 | 1 | Kit, 7.8 In Fan | 18 | 76-1900 | 2 | O-Ring |
| 3 | 116-0234 | 1 | Pulley Kit | 19 | 116-8662 | 2 | O-Ring-Valve, Check |
| 4 | 116-0235 | 1 | Handle | 20 | 116-8974 | 4 | Screw-HH 1/2-20 X 2 1/4 |
| 5 | 116-0236 | 1 | Dipstick | 21 | 116-8975 | 2 | Screw-HSH 1/2-20 X 2 3/4 |
| 6 | 116-0237 | 1 | Gasket | 22 | 116-9922 | 2 | Hydraulic Tube Kit |
| 7 | 116-1367 | 1 | Swash Block Kit | 23 | 126-7466 | 1 | Valve-Shock |
| 8 | 142-3604 | 1 | Kit, Pump Seal | 24 | 126-7711 | 1 | Seal-Drive, Fan |
| 9 | 116-1369 | 1 | Motor Seal Kit | 25 | 142-3608 | 1 | Kit, Pump Section 12Cc RH |
| 10 | 116-1370 | 1 | Tube Seal Kit | 26 | 142-4500 | 1 | Kit - 12Cc Port Plate, Rotate Grp |
| 11 | 116-1371 | 1 | Output Shaft Seal Kit | | | | |
| 12 | 116-5469 | 1 | Cup-Nose | 27 | 142-4459 | 1 | Shock Valve Orificed 3800 |
| 13 | 3257-42 | 1 | Key-Woodruff 5/16 X 1 | 99 | 116-1373 | 1 | Flow Test Kit ● |
| 15 | 142-4461 | 1 | Kit, Housing-Hydro RH | 99 | 116-4245 | 1 | Puller-Pulley ● |
| 16 | 116-8916 | 1 | Motor-Hydraulic RH 240Cc | | | | |

● Not illustrated

Pump Idler Assembly No. 116-1255

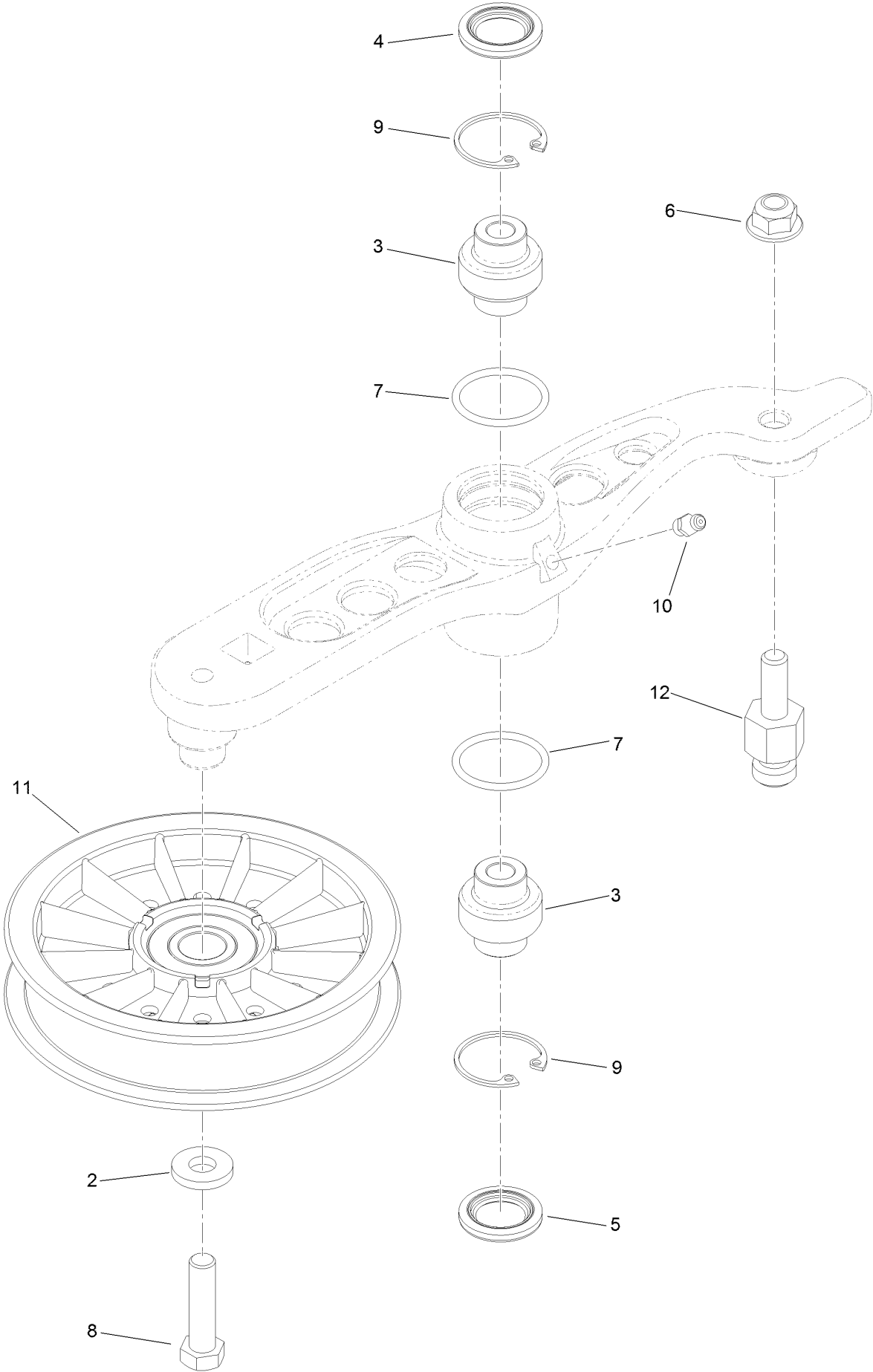

Pump Idler Assembly No. 116-1255 (continued)

| <i>Ref.</i> | <i>Part Number</i> | <i>Qty.</i> | <i>Description</i> | <i>Ref.</i> | <i>Part Number</i> | <i>Qty.</i> | <i>Description</i> |
|-------------|--------------------|-------------|--------------------|-------------|--------------------|-------------|--------------------|
| 2 | 43-0940 | 1 | Spacer | 8 | 323-8 | 1 | Screw-HH |
| 3 | 103-3504 | 2 | Bearing-Spherical | 9 | 32120-10 | 2 | Ring-Snap |
| 4 | 103-3505 | 1 | Seal-Lip, Double | 10 | 302-19 | 1 | Fitting-Grease |
| 5 | 103-3506 | 1 | Seal-Lip, Single | 11 | 109-8076 | 1 | Pulley-Idler |
| 6 | 109-6658 | 1 | Nut-Flange, NI | 12 | 132-4724 | 1 | Pin-Anchor, Spring |
| 7 | 106-7159 | 2 | O-Ring | | | | |

Electrical Assembly

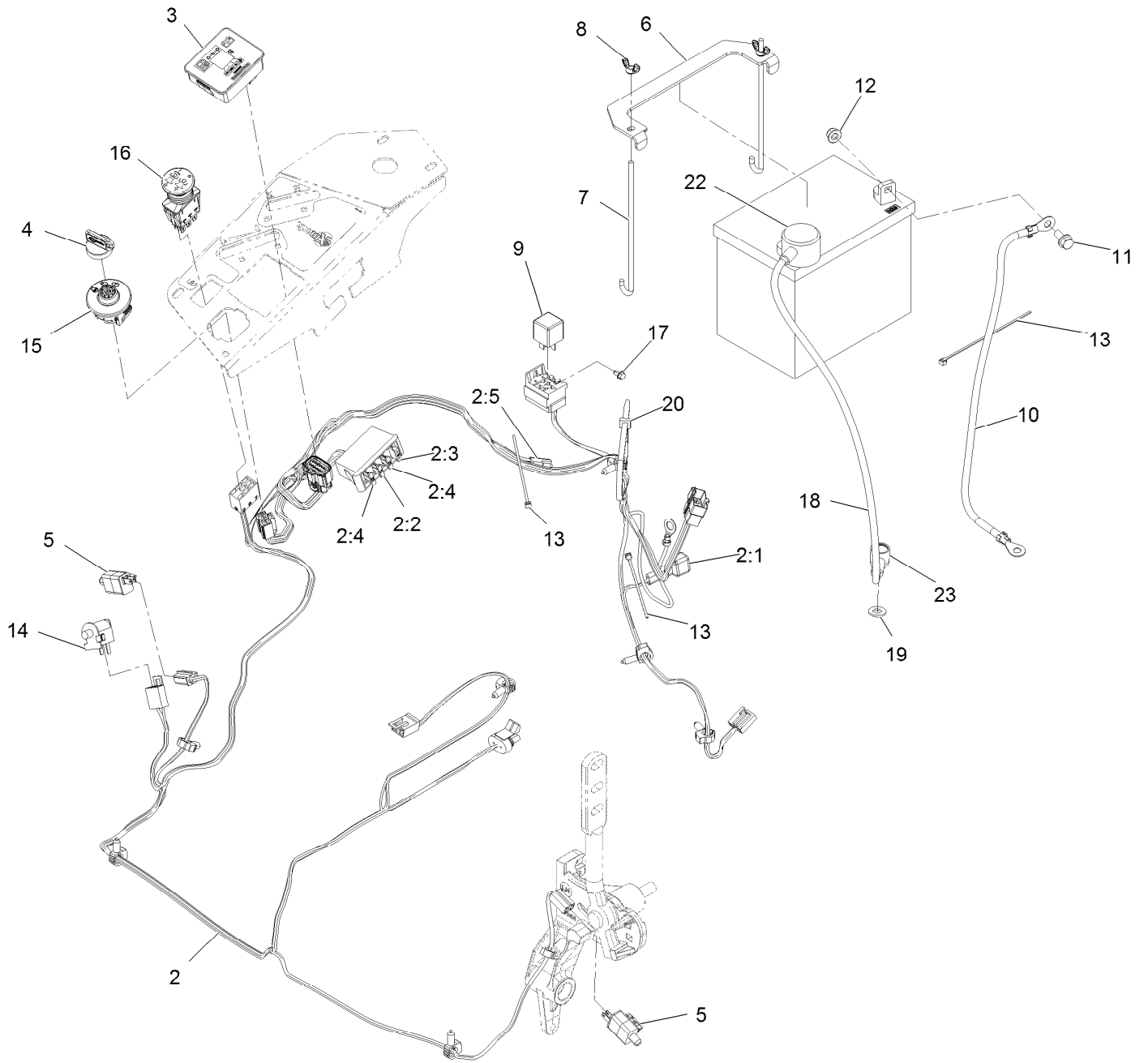

Electrical Assembly (continued)

| <i>Ref.</i> | <i>Part Number</i> | <i>Qty.</i> | <i>Description</i> | <i>Ref.</i> | <i>Part Number</i> | <i>Qty.</i> | <i>Description</i> |
|-------------|--------------------|-------------|-------------------------|-------------|--------------------|-------------|----------------------------|
| 2 | 116-6009 | 1 | Harness-Wire, Main ● | 10 | 114-1218 | 1 | Cable-Battery, Negative |
| 2:1 | 103-3895 | 1 | Diode | 11 | 3234-5 | 2 | Screw-HH Flg 5/16-18 X 3/4 |
| 2:2 | 218-578 | 1 | Fuse-Blade, 10 Amp | 12 | 104-8300 | 2 | Nut-Nyloc 5/16-18 Flg |
| 2:3 | 109355 | 1 | Fuse-Blade, 15 Amp | 13 | 1-303287 | 3 | Tie-Cable 5 1/2 (Small) |
| 2:4 | 109102 | 2 | Fuse-Blade, 25 Amp | 14 | 82-2190 | 1 | Switch |
| 2:5 | 116-0053 | 1 | Cap-Plug | 15 | 137-4100 | 1 | Switch-Ignition |
| 3 | 117-3882 | 1 | Fuel/Hour Meter ASM | 16 | 135-3653 | 1 | Switch, PTO 10A |
| 4 | 1-603511 | 1 | Key-Ignition | 17 | 104-2065 | 1 | Screw-HWH #10-24 X 3/8 |
| 4 | 103-2106 | 1 | Key-Exmark Logo | 18 | 115-3864 | 1 | Cable-Battery, Positive |
| 5 | 110-6765 | 2 | Switch | 19 | 3256-24 | 1 | Washer-3/8 SAE |
| 6 | 116-0042-03 | 1 | Strap-Tie Down, Battery | 20 | 3290-378 | 1 | Tie-Cable |
| 7 | 1-633651 | 2 | Bolt-Holddown | 22 | 109-2407 | 1 | Insulator-Battery |
| 8 | 1-543792 | 2 | Wingnut-Nyloc 1/4-20 | 23 | 1-543393 | 1 | Insulator-Solenoid |
| 9 | 1-643275 | 1 | Relay-12Vdc 40 Amp | | | | |

● Use dielectric grease on all unsealed connectors and terminals only. Do not apply in sealed connectors.

Notes:



MAXIMIZE THE PERFORMANCE OF YOUR EXMARK MACHINE.



EXMARK® PREMIUM ENGINE OIL

Exmark now offers a family of engine oil viscosities to perform well in any environment. Each viscosity has the same synthetic formulation to give you what you need in punishing conditions. We designed each grade to the highest quality, making it ideal even for diesel applications. Coupled with Exmark Premium Fuel Treatment, we have the performance products to make your machine hum.

EXMARK PREMIUM ENGINE OIL SAE 30/10W-30

- Meets zero shear requirements of a straight grade SAE 30 as well as the cold temp properties of a 10W-30.
- Most versatile oil in the industry.
- Superior corrosion protection over conventional oil - even in corrosive, humid environments.

EXMARK PREMIUM ENGINE OIL SAE 20W-50

- Perfect for your big block engine, or any application in severe service.
- Same full synthetic formulation as all other Exmark Premium viscosities.
- Also effective for use in severe service small block engines.

EXMARK PREMIUM ENGINE OIL SAE 10W-50

- Full synthetic formulation gives you peak performance. Don't settle for less.
- Wide span multi-grade combines easy starting in cold weather with maximum protection in high temperature operation.
- Reduce friction & wear over standard mineral formulations.

EXMARK PREMIUM ENGINE OIL SAE 0W-40

- The perfect choice for when the weather turns cold or unpredictable, and your Exmark UTV has to perform.
- Commercial quality for severe service.
- Advanced additive package helps prevent corrosion from long-term storage.

EXMARK PREMIUM ENGINE OIL UTV FORMULATION

- 4-cycle high-temp formulation.
- Heavier viscosity, full synthetic, perfect for your UTV.

EXMARK PREMIUM UTV EXTREME CONDITIONS GEAR OIL

- SAE 80W-90, designed to keep your UTV performing at its peak.
- Shear stable, hypoid gear lube.
- Includes a premium additive system to combat wear, oxidation, rust & corrosion.

Available from your local Exmark dealer. Find your closest dealer at exmark.com

EXMARK ACCESSORIES AND OPTIONS*

MID-MOUNT RIDING ACCESSORIES AND OPTIONS

| | |
|------------------------------------|---------------------------------|
| CUSTOM RIDE SEAT SUSPENSION SYSTEM | OPERATOR CONTROLLED DISCHARGE |
| FULL SUSPENSION SEAT | SUN SHADE |
| DECK LIFT ASSIST KIT | TRASH CONTAINER |
| HITCH KIT | TURF STRIPER |
| LIGHT KIT | ULTRA VAC COLLECTION SYSTEM |
| 12V POWER PORT | ULTRA VAC QUICK DISPOSAL SYSTEM |
| MICRO-MULCH SYSTEM | |

OUT-FRONT RIDING ACCESSORIES AND OPTIONS

| | |
|------------------------------------|---------------------------------|
| CUSTOM RIDE SEAT SUSPENSION SYSTEM | SNOW BLADE |
| DUAL-TAIL WHEEL | SNOWBLOWER |
| FLOOR PAN EXTENDER | SUN SHADE |
| HITCH KIT | TRASH CONTAINER |
| LIGHT KIT | ULTRA VAC COLLECTION SYSTEM |
| MICRO-MULCH SYSTEM | ULTRA VAC QUICK DISPOSAL SYSTEM |
| ROLL OVER PROTECTION SYSTEM (ROPS) | WEATHER CAB |

WALK-BEHIND ACCESSORIES AND OPTIONS

| | |
|--------------------|--------------|
| GRASS CATCHER | TURF STRIPER |
| MICRO-MULCH SYSTEM | STANDON |

*Some accessories and options not available for some models.

Place Model No. and Serial No.
Label Here (Included in the Literature
Pack) or Fill in Below

Model No. _____

Serial No. _____

Date Purchased _____

Engine Model No. and Spec. No. _____

Engine Serial No. (E/No) _____

© 2021 Exmark Mfg. Co., Inc.
415 Industrial Row
Beatrice, NE 68310
All Rights Reserved

Part No. 4505-968 Rev. A
(402) 223-6375
Fax (402) 223-5489
Printed in the USA.

