

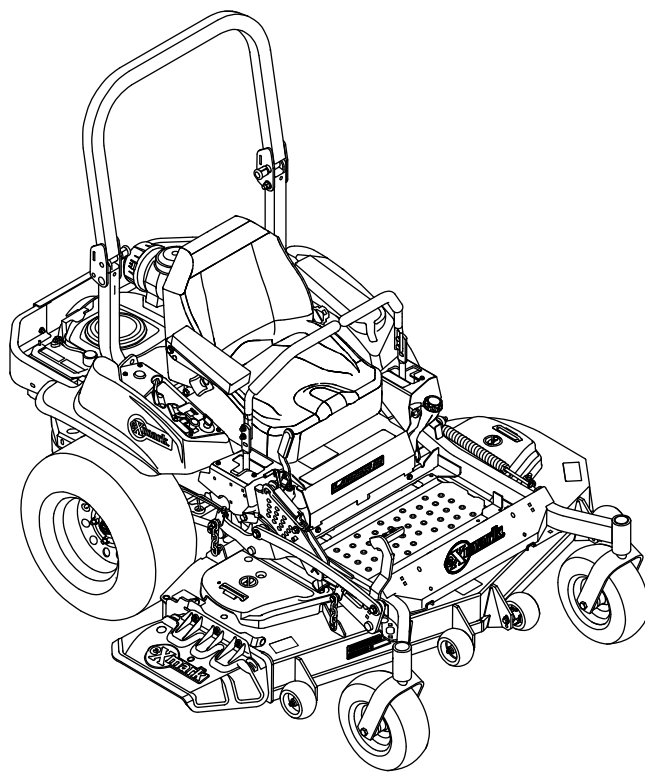

LAZER Z[®] X-SERIES

Model No. LZX993EBV606X1—Serial No. 411294212 and Up

Picture below may not reflect actual product.



Parts Manual

Part No. 4505-754 Rev. B

Ordering Replacement Parts

To order replacement parts, please supply the part number, the quantity, and the description of each part desired.

Understanding Reference Numbers

Each identified part in an illustration has a reference number. The reference number for a part also appears in the parts list, along with other information about the part.

This catalog uses two special reference number formats, one to indicate parts in a service assembly and another to indicate the quantity of a given part in an illustration.

Service Assembly Reference Numbers

Parts in service assemblies have reference numbers in the form a:b. The a represents the reference number of the entire service assembly and the b represents a sequential number unique to each part within the service assembly.

For example, a wheel assembly might be identified by reference number 6, the tire by 6:1, the valve by 6:2, and the wheel by 6:3. When you order the assembly identified by reference number 6, you receive all parts identified by reference numbers 6:1, 6:2, and 6:3. However, you may also order any part individually. Reference numbers of this type appear in illustration and in parts lists.

Reference Numbers Indicating Quantity

In an illustration, if a reference number indicates more than one part, the reference number has the form nX y. The n represents the quantity of the part, the X is the multiplication symbol, and the y represents the reference number.

For example, in an illustration, the reference number 2X 37 means that two of the parts identified by reference number 37 are indicated.

Touch Up Paint

Exmark black touch up spray paint – gloss black.

Exmark red touch up paint (spray paint – P/N 1-850337 - .6 oz liquid bottle – P/N 103-9140).

Contents

Complete Deck Assembly	4
Deck Assembly	6
Deck W/Decals Assembly No. 116-4232	8
Idler Assembly	10
Cutter Housing Assembly No. 103-9539	12
Main Frame Assembly	14
Main Frame W/Decals Assembly	16
X-Series Decal	18
Roll-Over Protection System	20
Roll Over Protection System (cont.)	22
Front Caster and Fork Assembly	24
Caster Wheel and Fork Assembly	26
Deck Lift Assembly	28
Height-of-Cut Assembly No. 109-7438	30
Controls Assembly	32
Motion Control Assembly	34
Rear Wheel Assembly	36
Park Brake Assembly	38
Seat Assembly	40
Seat Assembly (cont.)	42
Fuel Assembly	44
Fuel Tank Assembly	46
Engine Assembly	48
Hydraulic Assembly	50
LH Hydro Assembly No. 135-7907	52
RH Hydro Assembly No. 135-7908	54
Pump Idler Assembly No. 116-1255	56
Electrical Assembly	58

Complete Deck Assembly

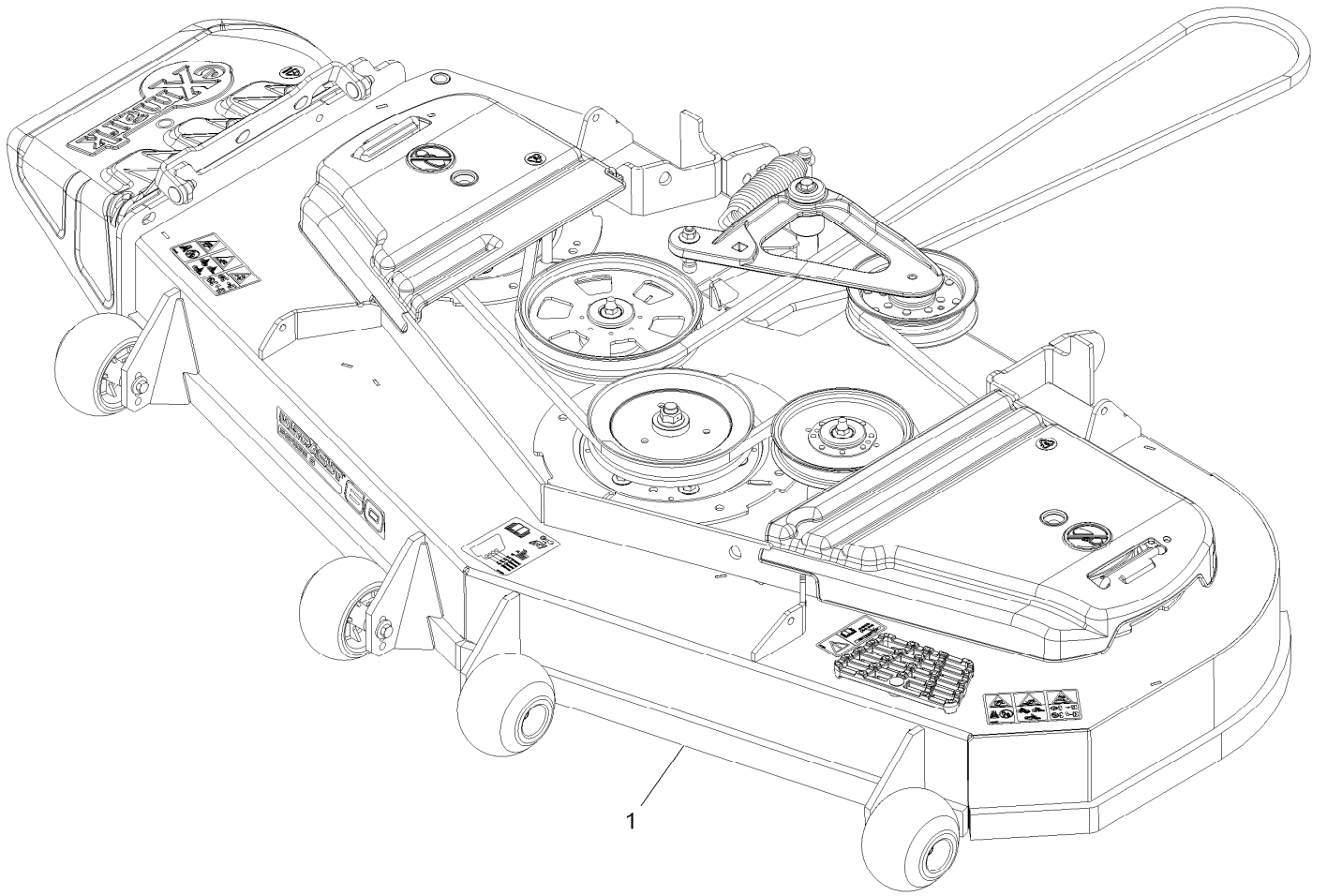

Complete Deck Assembly (continued)

<i>Ref.</i>	<i>Part Number</i>	<i>Qty.</i>	<i>Description</i>
1	142-8386	1	ASM,Deck Complete 606

Deck Assembly

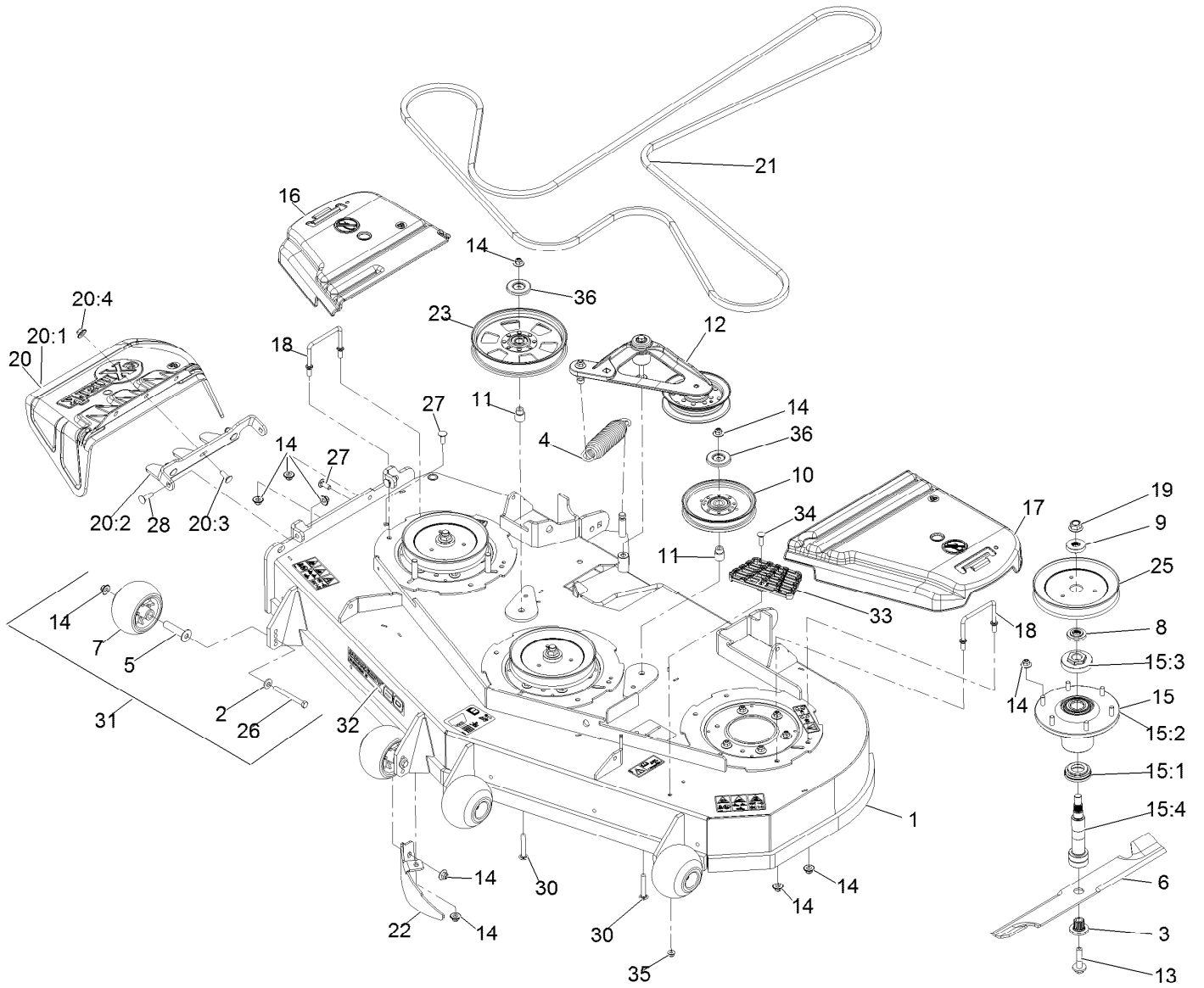

Deck Assembly (continued)

<i>Ref.</i>	<i>Part Number</i>	<i>Qty.</i>	<i>Description</i>	<i>Ref.</i>	<i>Part Number</i>	<i>Qty.</i>	<i>Description</i>
1	116-4232	1	Deck ASM,W/Decals 60	17	109-6938	1	Cover-Belt, LH
2	98-5975	4	Washer-Spring Disc 3/8	18	109-6982	2	Wireform-Cover
3	103-3037	3	Bushing, Splined	19	109-7033	3	Nut-Flange 5/8-18 Centerlock ▲
4	116-6317	1	Spring-Extension	20	109-7188	1	ASM,Discharge Chute
5	116-8131	4	Axle, Roller	20:1	109-2738	1	Chute, Discharge
6	103-6383	3	Blade, Solid ●	20:2	109-8675-01	1	Bracket,Discharge Chute
6	103-6388	3	Blade, Low Lift ●	20:3	3231-22	3	Bolt-Carriage 3/8-16 X 1
6	103-6393	3	Blade, Mulching □	20:4	109-6658	3	Nut-Nyloc 3/8-16 Flg
6	103-6403	3	Blade, Notched	21	109-8073	1	Belt,V-5V-198.75
6	116-5174	3	Blade-Extreme 2, 20.50" ●	22	116-5614-01	1	Dogleg - Lz60
7	103-8415	4	Roller-Anti-Scalp	23	116-9639	1	Pulley-Idler, Flat
8	103-9522	3	Spacer, Splined Stepped	25	109-9511	3	Sheave,Blade Drive 7.25
9	103-9523	3	Spacer, Splined	26	116-9362	4	Screw-HH 3/8-16 X 3 3/4 GR 8
10	126-7685	1	Idler-Pulley	27	3231-22	2	Bolt-Carriage 3/8-16 X 1
11	1-633456	2	Bushing, Idler	28	3231-28	2	Bolt-Carriage 3/8-16 X 1 1/4
12	116-3755	1	Deck Idler ASM	30	3231-44	2	Bolt-Carriage 3/8-16 X 2 1/2
13	109-9220	3	Screw-Sems 1/2-20 X 2.19 ■	31	116-9981	4	Kit, Anti-Scalp Roller
14	109-6658	32	Nut-Nyloc 3/8-16 Flg	32	126-6592	1	Decal, 606
15	109-6917	3	ASM,Spindle Housing	33	126-4781-03	1	Step-Deck
15:1	103-9504	1	Guard, Bottom	34	3230-3	1	Bolt-Carriage 5/16-18 X 1 1/4
15:2	103-9539	1	Asm, Cutter Housing	35	104-8300	1	Nut-Nyloc 5/16-18 Flg
15:3	109-0916	1	Nut, Spindle 7/8-14 ◆	36	126-8043	2	Shield-Dust
15:4	109-6881	1	Spindle,Double Spline ○				
16	116-0094	1	Cover-Belt, RH				

● Optional Equipment

▲ Torque to 90-110 ft-lb

□ Requires installation of mulch kit for proper mulching. See your Exmark dealer for details.

○ Apply Mobil HTS grease (P/N 103-5217 1.5 oz packet) (or a food-grade anti-seize). See operator s manual for locations.

▶ Apply lubricant to threads as needed to prevent seizing. Copper based anti-seize preferable. Grease is an acceptable substitute.

■ Torque to 55-60 ft-lb

◆ Torque to 160-185 ft-lb

Deck W/Decals Assembly No. 116-4232

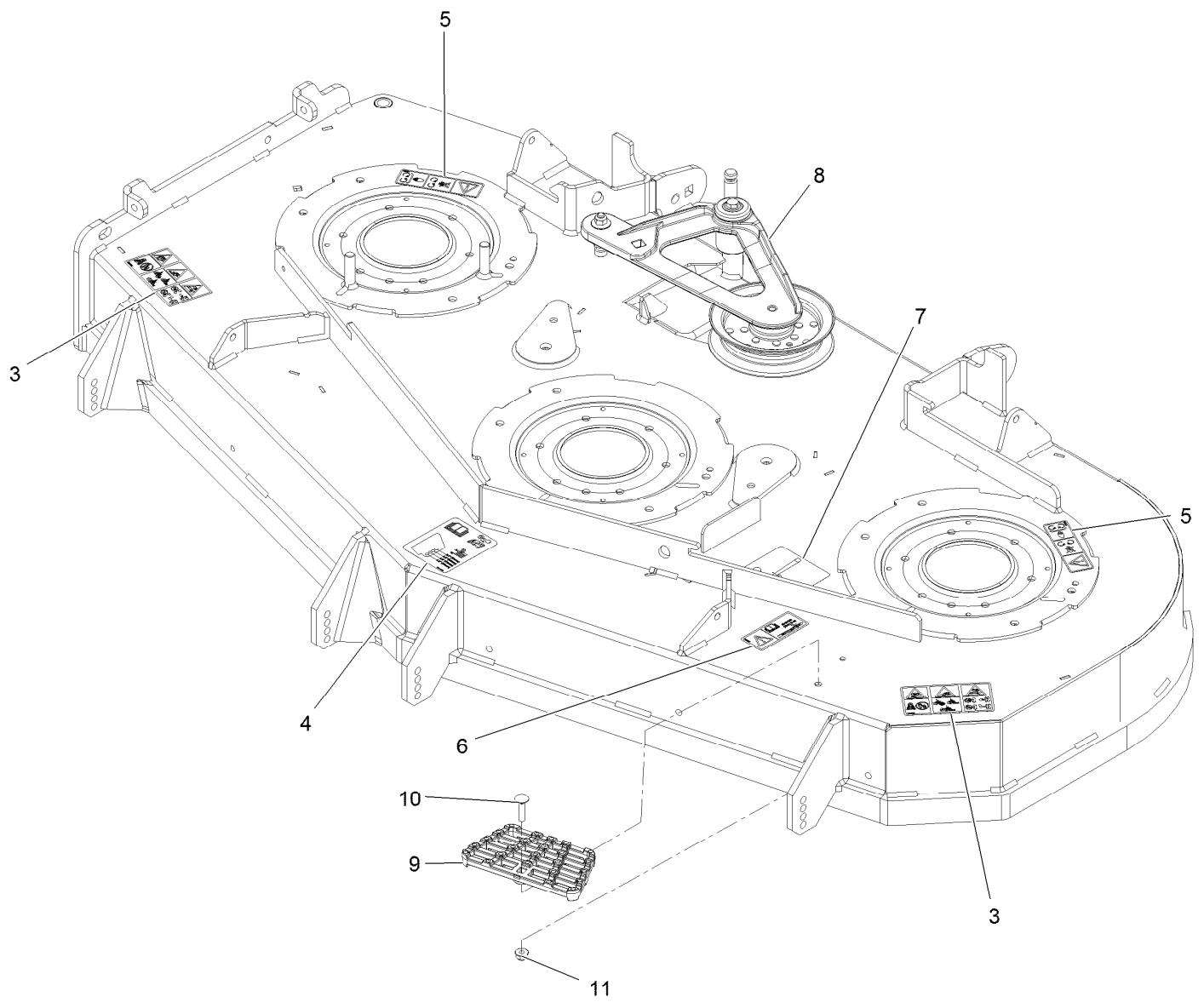

Deck W/Decals Assembly No. 116-4232 (continued)

<i>Ref.</i>	<i>Part Number</i>	<i>Qty.</i>	<i>Description</i>	<i>Ref.</i>	<i>Part Number</i>	<i>Qty.</i>	<i>Description</i>
3	126-6464	2	Decal-Danger Thrown Objects	8	116-3755	1	Deck Idler ASM
4	109-6036	1	Decal-Roller, Anti-Scalp	9	126-4781-03	1	Step-Deck
5	112-9028	2	Decal-Cover, Missing	10	3230-3	1	Bolt-Carriage 5/16-18 X 1 1/4
6	116-8283	1	Decal-Torque, Bolt	11	104-8300	1	Nut-Nyloc 5/16-18 Flg
7	116-8727	1	Decal-Belt Routing				

Idler Assembly

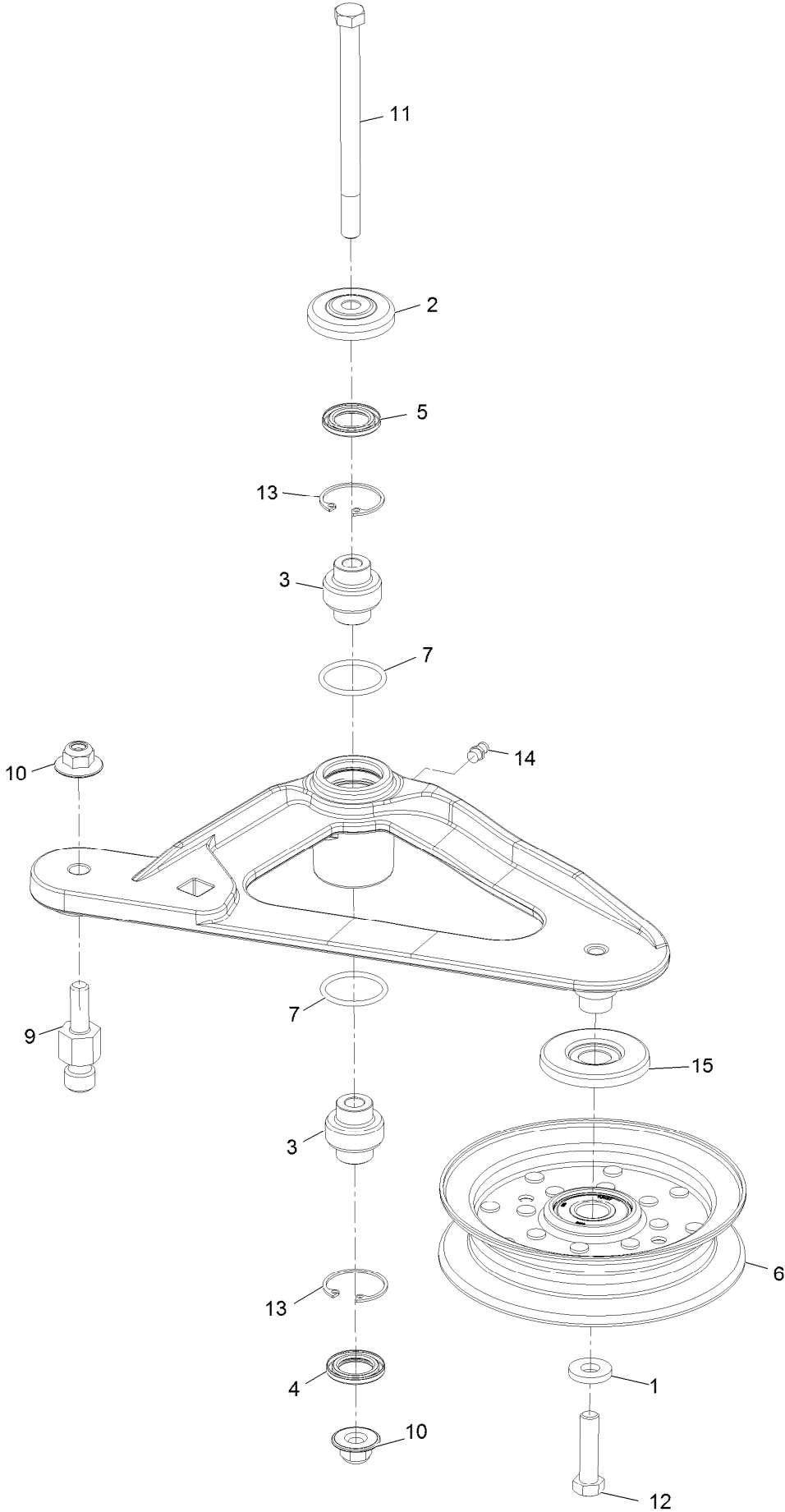

Idler Assembly (continued)

<i>Ref.</i>	<i>Part Number</i>	<i>Qty.</i>	<i>Description</i>	<i>Ref.</i>	<i>Part Number</i>	<i>Qty.</i>	<i>Description</i>
1	43-0940	1	Spacer	9	126-0423	1	Pin-Spring, Anchor
2	103-2916	1	Guard-Top	10	109-6658	2	Nut-Flange, NI
3	103-3504	2	Bearing-Spherical	11	109-7409	1	Screw-Shoulder, HH
4	103-3505	1	Seal-Lip, Double	12	323-8	1	Screw-HH
5	103-3506	1	Seal-Lip, Single	13	32120-10	2	Ring-Snap
6	126-9196	1	Idler-Pulley, Flat	14	302-19	1	Fitting-Grease
7	106-7159	2	O-Ring	15	126-9195	1	Shield-Guard, Dust

Cutter Housing Assembly No. 103-9539

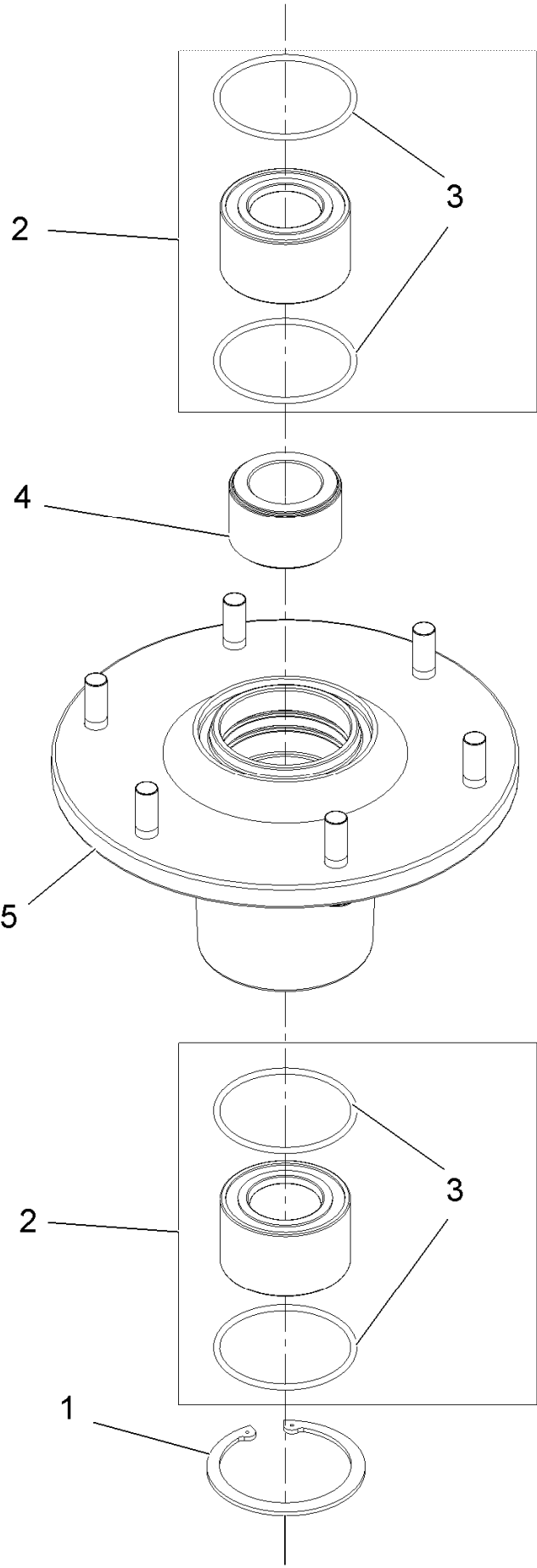

Cutter Housing Assembly No. 103-9539 (continued)

<i>Ref.</i>	<i>Part Number</i>	<i>Qty.</i>	<i>Description</i>
1	92-5581	1	Ring-Rtng,Snap,Int,Flat
2	109-2064	1	Asm, Bearing W/O-Rings
3	103-5895	4	O-Ring

<i>Ref.</i>	<i>Part Number</i>	<i>Qty.</i>	<i>Description</i>
4	103-9506	1	Spacer, Bearing
5	109-0764	1	Asm, Housing W/Studs

Main Frame Assembly

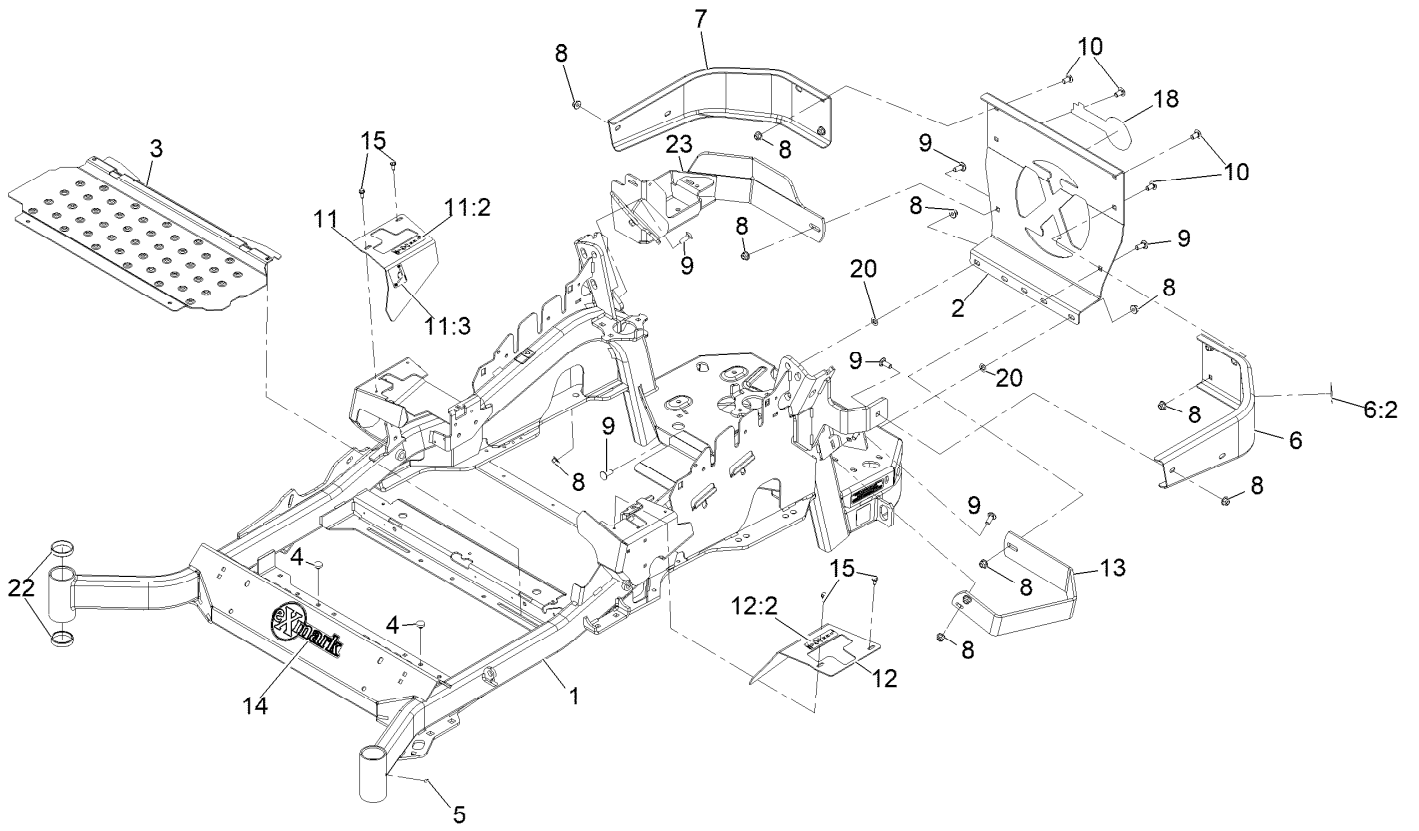

Main Frame Assembly (continued)

<i>Ref.</i>	<i>Part Number</i>	<i>Qty.</i>	<i>Description</i>	<i>Ref.</i>	<i>Part Number</i>	<i>Qty.</i>	<i>Description</i>
1	142-7265	1	Mainframe Service ASM - 60	11:2	99-8936	1	Decal-Control, Motion
2	109-8863-03	1	Plate,Rear Guard	11:3	116-5988	1	Decal-Park Brake, CE
3	116-8898-01	1	Floorpan	12	116-0580	1	LH Motion Control Cover ASM
4	1-513658	2	Bumper	12:2	99-8936	1	Decal-Control, Motion
5	1-811010	2	Plug	13	126-2067-03	1	Guard-Muffler
6	116-0180	1	LH Bumper ASM	14	135-2274	1	Decal-Exmark
6:2	106-5517	1	Decal-Warning	15	32144-10	4	Screw-HWH 1/4-20 X .62
7	116-0057-03	1	Bumper-RH	18	126-6877	1	Decal, Exmark Logo
8	104-8301	14	Nut-Nyloc 3/8-16 Flg	20	107-3154	2	Nut-Push 3/8-16
9	3231-22	10	Bolt-Carriage 3/8-16 X 1	22	1-543508	4	Cup-Bearing Tapered Roller
10	3231-21	4	Bolt-Carriage 3/8-16 X 3/4	23	142-6295-03	1	Battery Guard ASM [black]
11	116-5899	1	RH Motion Control Cover ASM				

Main Frame W/Decals Assembly

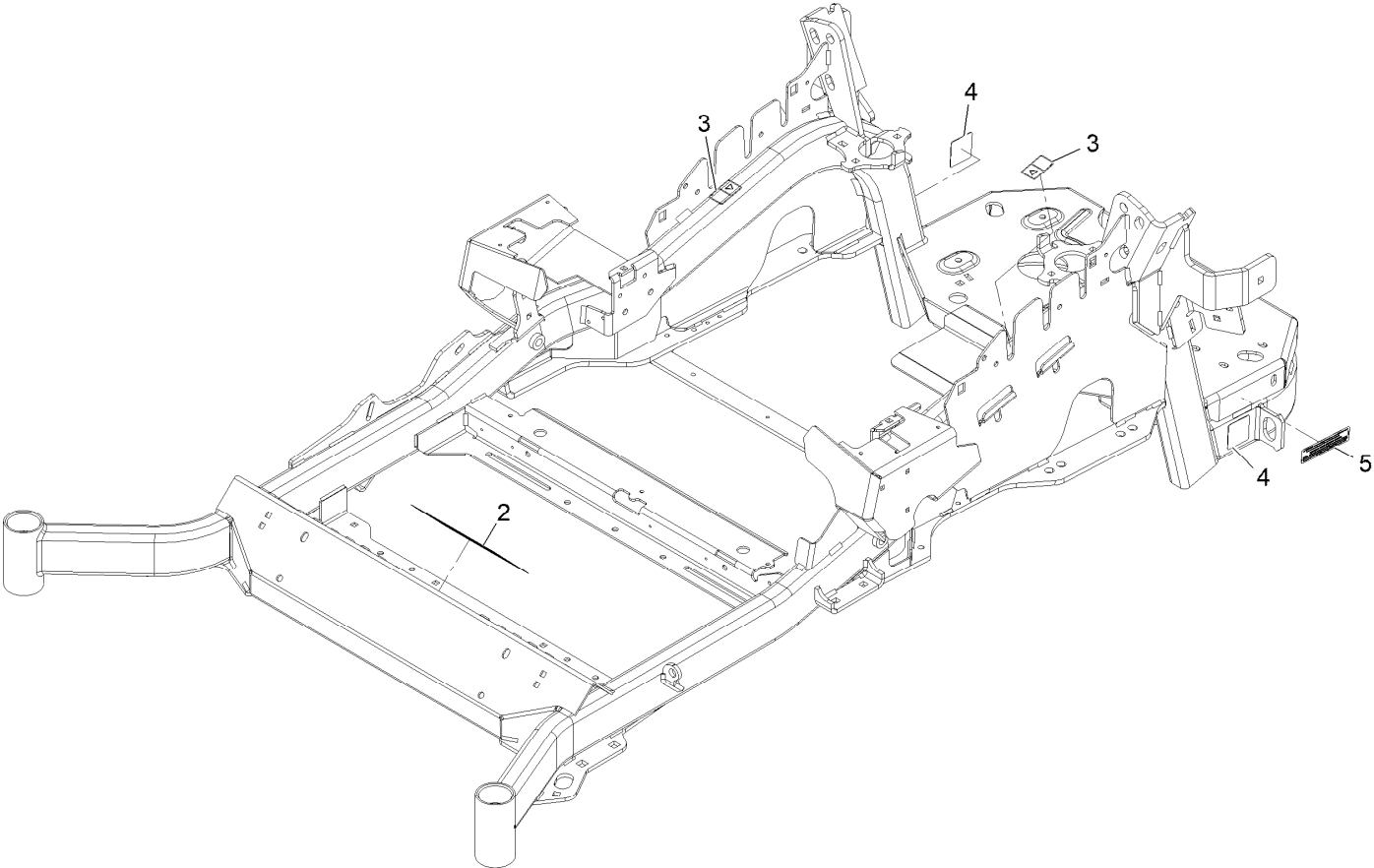

Main Frame W/Decals Assembly (continued)

<i>Ref.</i>	<i>Part Number</i>	<i>Qty.</i>	<i>Description</i>	<i>Ref.</i>	<i>Part Number</i>	<i>Qty.</i>	<i>Description</i>
2	132-0871	1	Decal-Danger	4	106-2655	2	Decal-Hazard, Pinched Finger
3	106-5517	2	Decal-Warning	5	133-8062	1	Decal-Arrestor, Spark

X-Series Decal

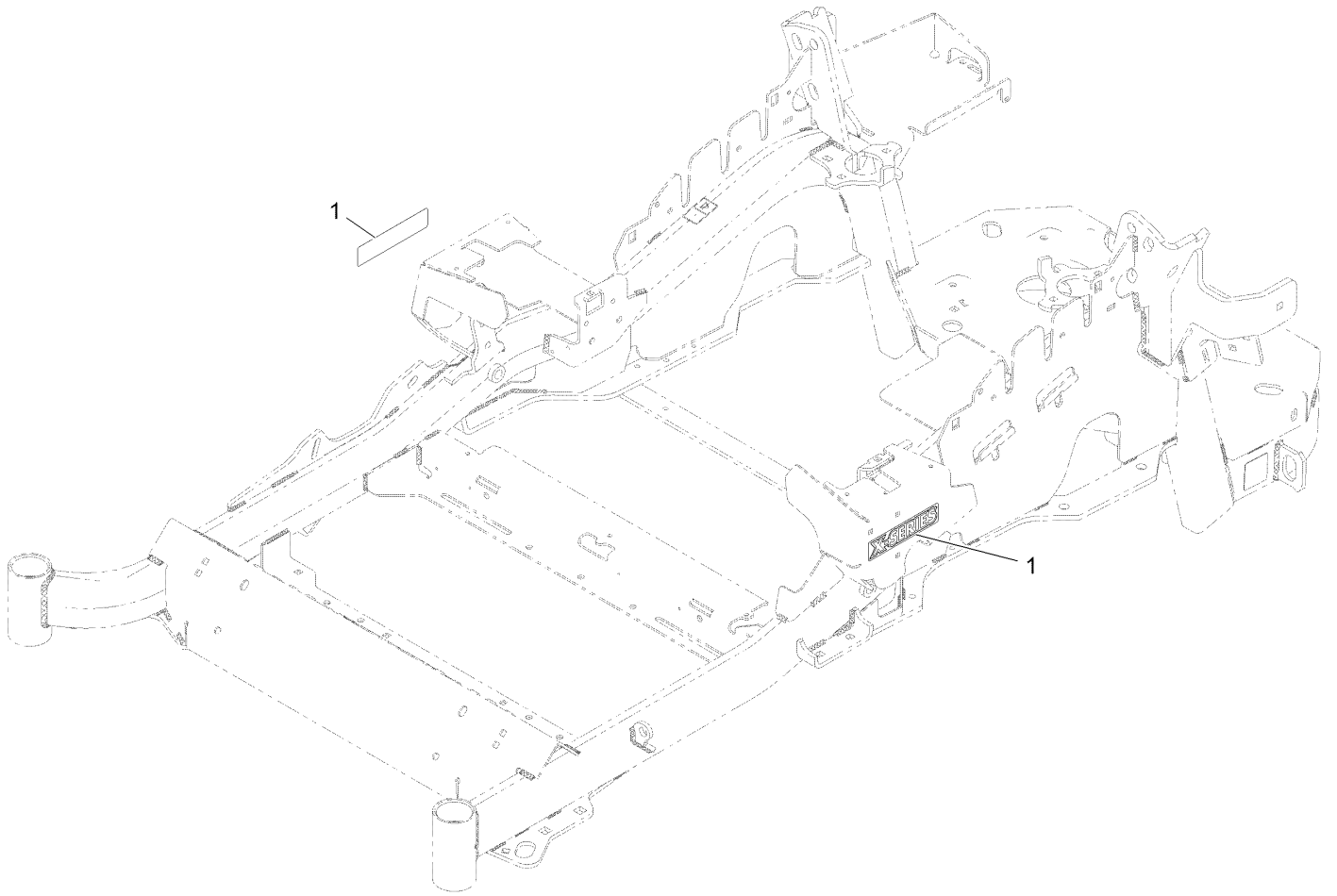

X-Series Decal (continued)

<i>Ref.</i>	<i>Part Number</i>	<i>Qty.</i>	<i>Description</i>
1	126-6573	2	Decal-X-Series

Roll-Over Protection System

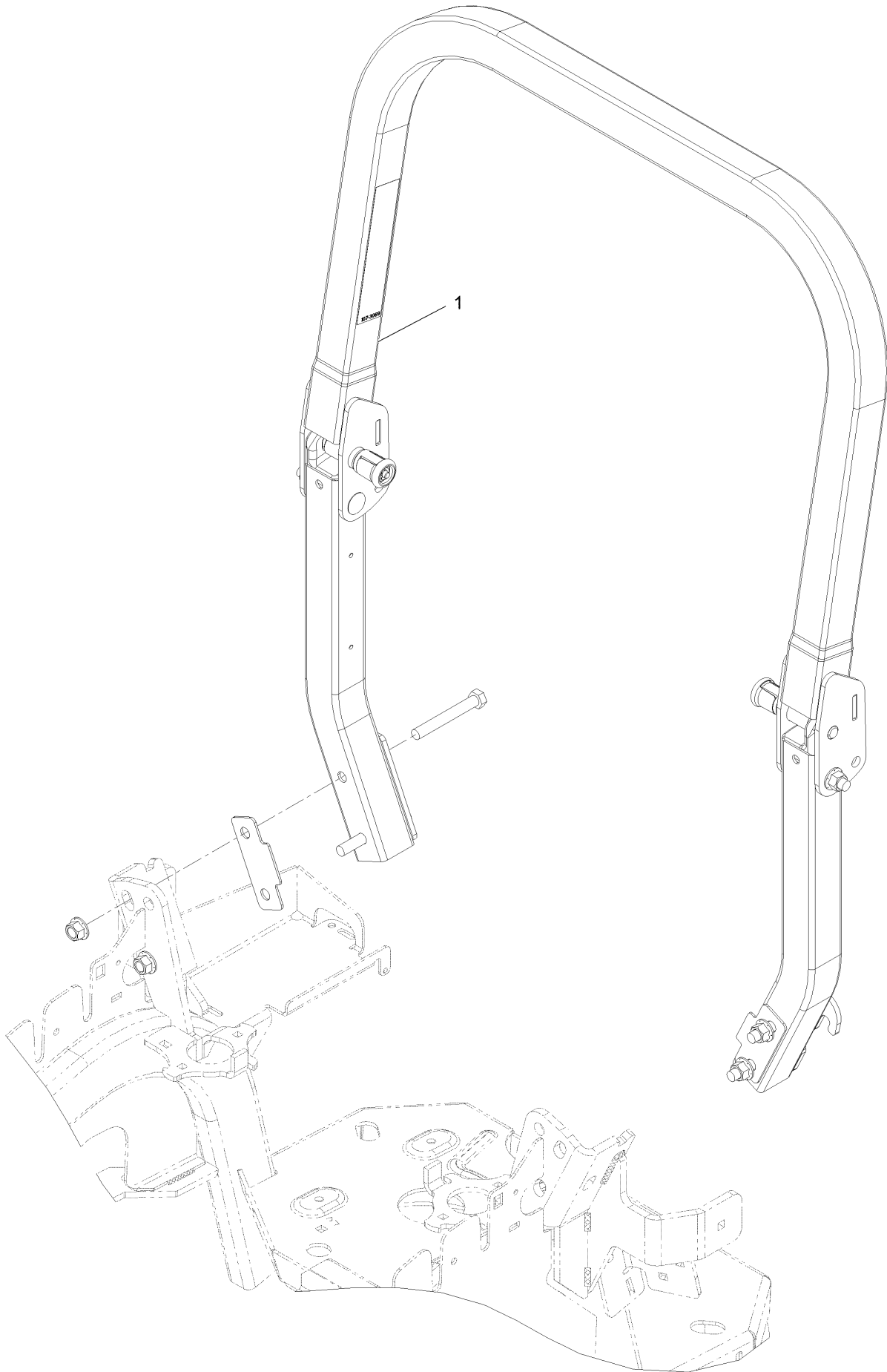

Roll-Over Protection System (continued)

<i>Ref.</i>	<i>Part Number</i>	<i>Qty.</i>	<i>Description</i>
1	116-0230	1	ASM,ROPS Service Exmark

Roll Over Protection System (cont.)

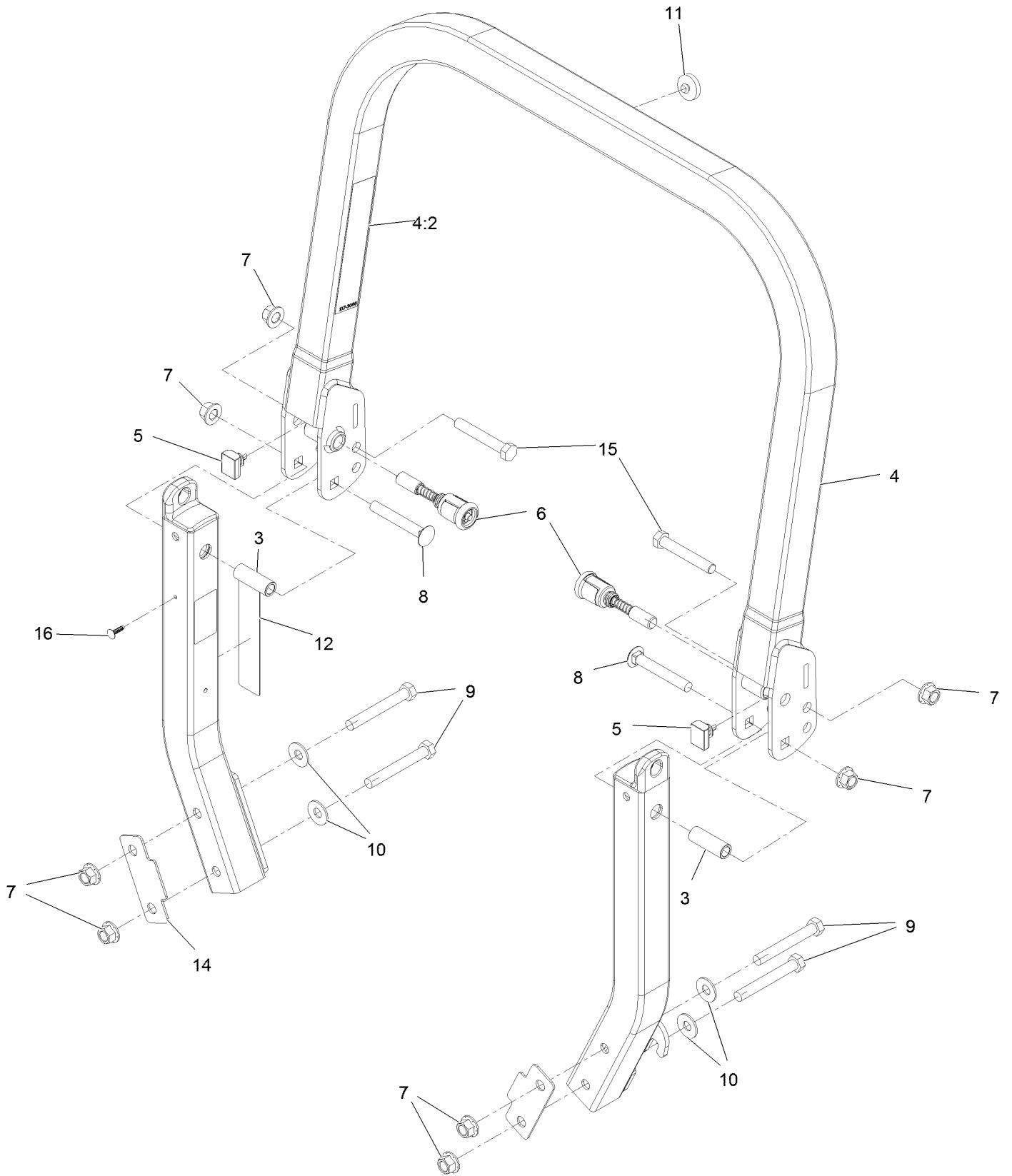

Roll Over Protection System (cont.) (continued)

<i>Ref.</i>	<i>Part Number</i>	<i>Qty.</i>	<i>Description</i>	<i>Ref.</i>	<i>Part Number</i>	<i>Qty.</i>	<i>Description</i>
3	109-6653	2	Spacer	9	325-35	4	Screw-HH
4	116-0019	1	Upper ROPS ASM	10	109-9505	4	Washer, Spring Disc 1/2
4:2	107-3069	1	Decal-Warning	11	109-9233	1	Bumper-Push-In, Rubber
5	109-5337	2	Bumper-ROPS	12	117-0346	1	Decal-Caution, Fuel Vent
6	116-0104	2	Pin-Spring	14	116-0960	2	Spacer
7	99-5107	8	Nut-Lock 1/2-13	15	325-13	2	Screw-HH
8	3233-10	2	Bolt-Carriage 1/2-13 X 3 1/2	16	125-8067	1	Plug-Plastic

Front Caster and Fork Assembly

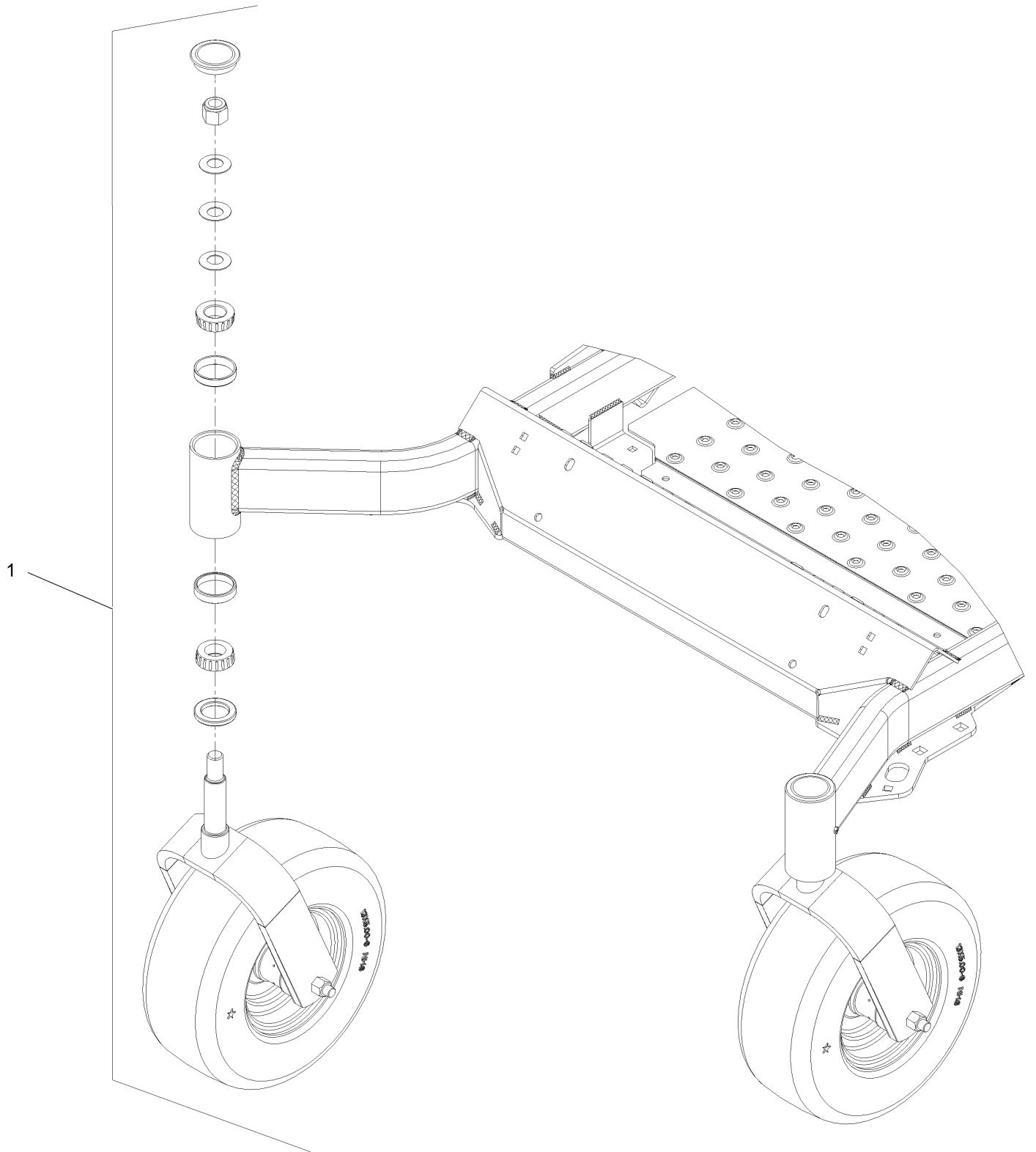

Front Caster and Fork Assembly (continued)

<i>Ref.</i>	<i>Part Number</i>	<i>Qty.</i>	<i>Description</i>
1		2	Front Caster And Fork ASM ●

● Not serviced separately

Caster Wheel and Fork Assembly

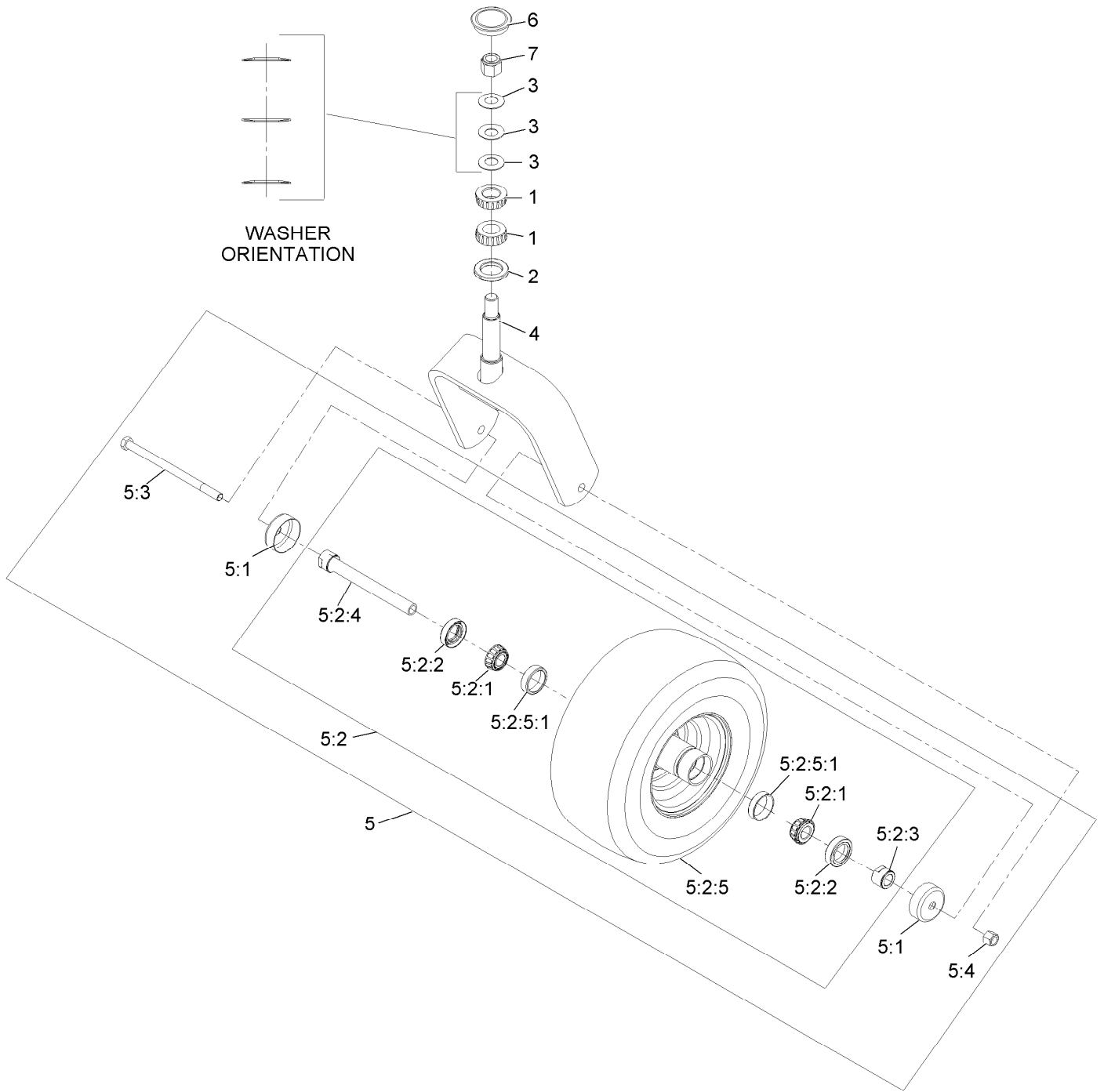

Caster Wheel and Fork Assembly (continued)

<i>Ref.</i>	<i>Part Number</i>	<i>Qty.</i>	<i>Description</i>	<i>Ref.</i>	<i>Part Number</i>	<i>Qty.</i>	<i>Description</i>
1	1-543509	2	Bearing-Roller, Tapered	5:2:3	103-3051	1	Spacer-Nut ■
2	116-5647	1	Seal-Grease	5:2:4	126-5361	1	Axle Caster ASM
3	1-633508	3	Washer-Bellville	5:2:5		1	Wheel And Tire ASM ●
4	116-6707-01	1	Caster	5:2:5:1	1-633584	2	Bearing-Cup
5	109-9127	1	Wheel & Tire ASM	5:3	325-39	1	Screw-HH
5:1	103-2768	2	Guard-Seal	5:4	3296-23	1	Nut-Lock, NI
5:2		1	Wheel And Tire ASM ●	6	103-4882	1	Cap-Grease
5:2:1	1-633585	2	Bearing-Cone, Taper	7	3296-51	1	Nut-Lock, NI
5:2:2	103-0063	2	Seal-Caster				

● Not serviced separately

■ Use Pro-Lock, Nut Type (P/N 1-840022, .5ml tube) on threads.

Deck Lift Assembly

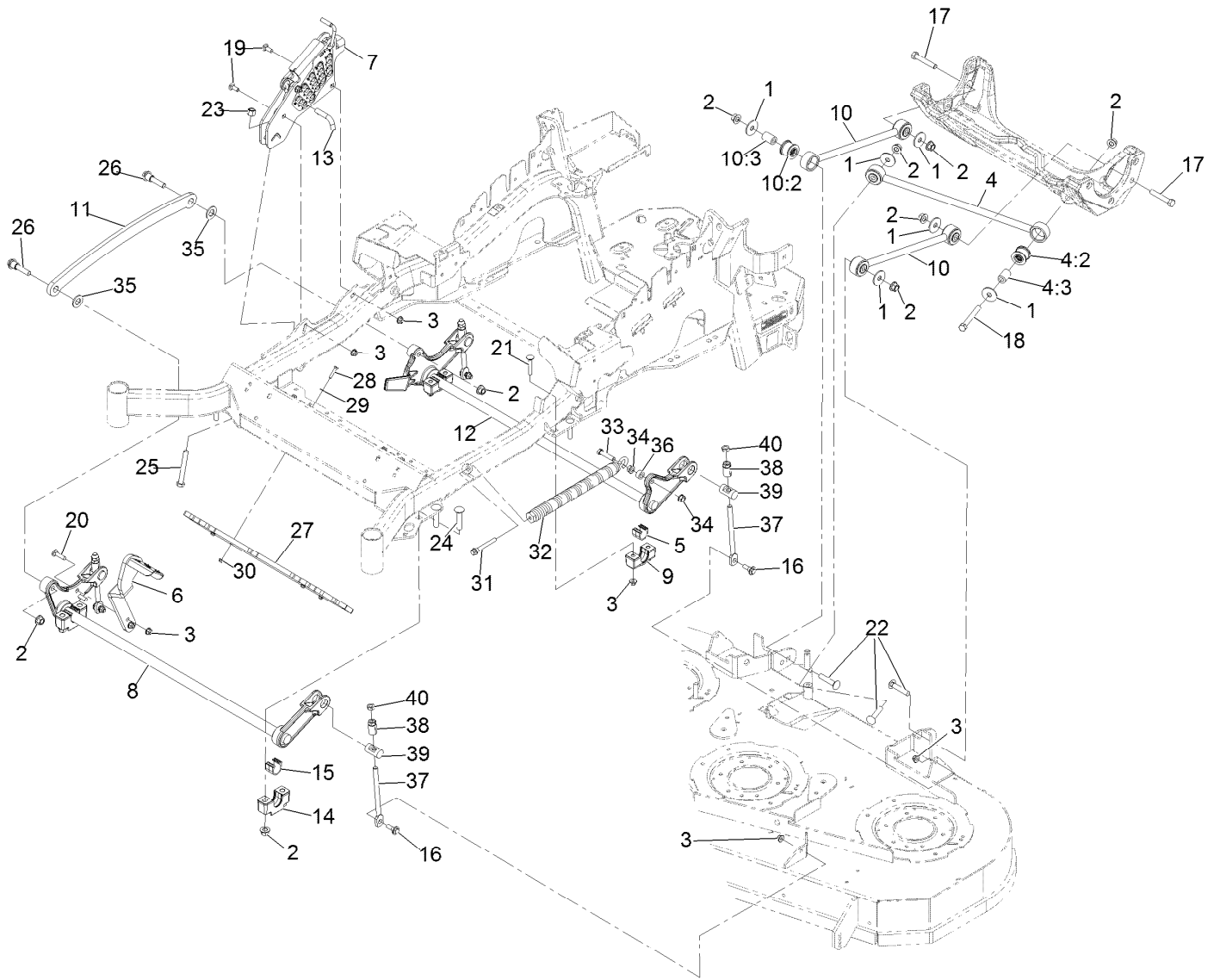

Deck Lift Assembly (continued)

<i>Ref.</i>	<i>Part Number</i>	<i>Qty.</i>	<i>Description</i>	<i>Ref.</i>	<i>Part Number</i>	<i>Qty.</i>	<i>Description</i>
1	86-1990	6	Washer	18	325-17	1	Screw-HH 1/2-13 X 4
2	99-5107	12	Nut-Lock 1/2-13	19	3231-2	2	Bolt-Carriage 3/8-16 X 1
3	104-8301	12	Nut-Nyloc 3/8-16 Flg	20	3231-4	2	Bolt-Carriage 3/8-16 X 1 1/2
4	109-5013	1	Panhard Rod ASM	21	3231-7	4	Bolt-Carriage 3/8-16 X 2 1/4
4:2	109-5009	2	Bushing-Suspension, Rubber	22	3233-34	3	Bolt-Carriage 1/2-13 X 2 1/2
4:3	109-5010	2	Spacer	23	3296-23	1	Nut-Nyloc 1/2-13
5	109-7173	2	Bearing-Cross Shaft, Rear	24	116-1700	4	Bolt-Carriage 1/2-13 X 2 1/2 Spl Neck
6	116-1919-01	1	Lever-Foot	25	116-0559	1	Bolt-HH 1/2-13 X 4 Tap
7	109-7438	1	HOC ASM	26	116-2022	2	Screw-Hex Flange 1/2-13 X 1.90
8	126-2477-03	1	Decklift-Front	27	140-4963-01	1	Weight-Toe Board
9	127-0553	2	Support-Bearing, Cross Shaft (Rear)	28	321-8	4	Screw-HH 1/4-20 X 1 1/4
10	109-7952	2	Deck Strut ASM	29	3256-22	4	Washer-1/4 SAE
10:2	109-5009	2	Bushing-Suspension, Rubber	30	104-7201	4	Nut-Nyloc 1/4-20 Flg
10:3	109-5010	2	Spacer	31	92-7674	1	Screw-SHCS 3/8-16 X 2.212
11	116-0797-03	1	Link-Lift, Deck	32	116-0000	1	Spring-Extension
12	116-2645-03	1	Lift-Deck, Rear	33	109-9065	1	Screw-HH 7/16-14 X 2
13	116-5584	1	Pin-HOC	34	32128-37	2	Nut-Whizlock 7/16-14
14	109-9409	2	Support-Bearing, Cross Shaft (Front)	35	3256-28	2	Washer-3/4 SAE
15	109-9410	2	Bearing-Cross Shaft, Front	36	116-2695	1	Spacer
16	109-9840	4	Screw-Hex Flange 3/8-16 X .80	37	109-8007	4	Link-Adjuster, Deck Lift
17	325-12	2	Screw-HH 1/2-13 X 3	38	109-7840	4	Adjuster-Lift, Deck
				39	109-8353	4	Trunnion
				40	3218-5	4	Nut-Jam 1/2-13

Height-of-Cut Assembly No. 109-7438

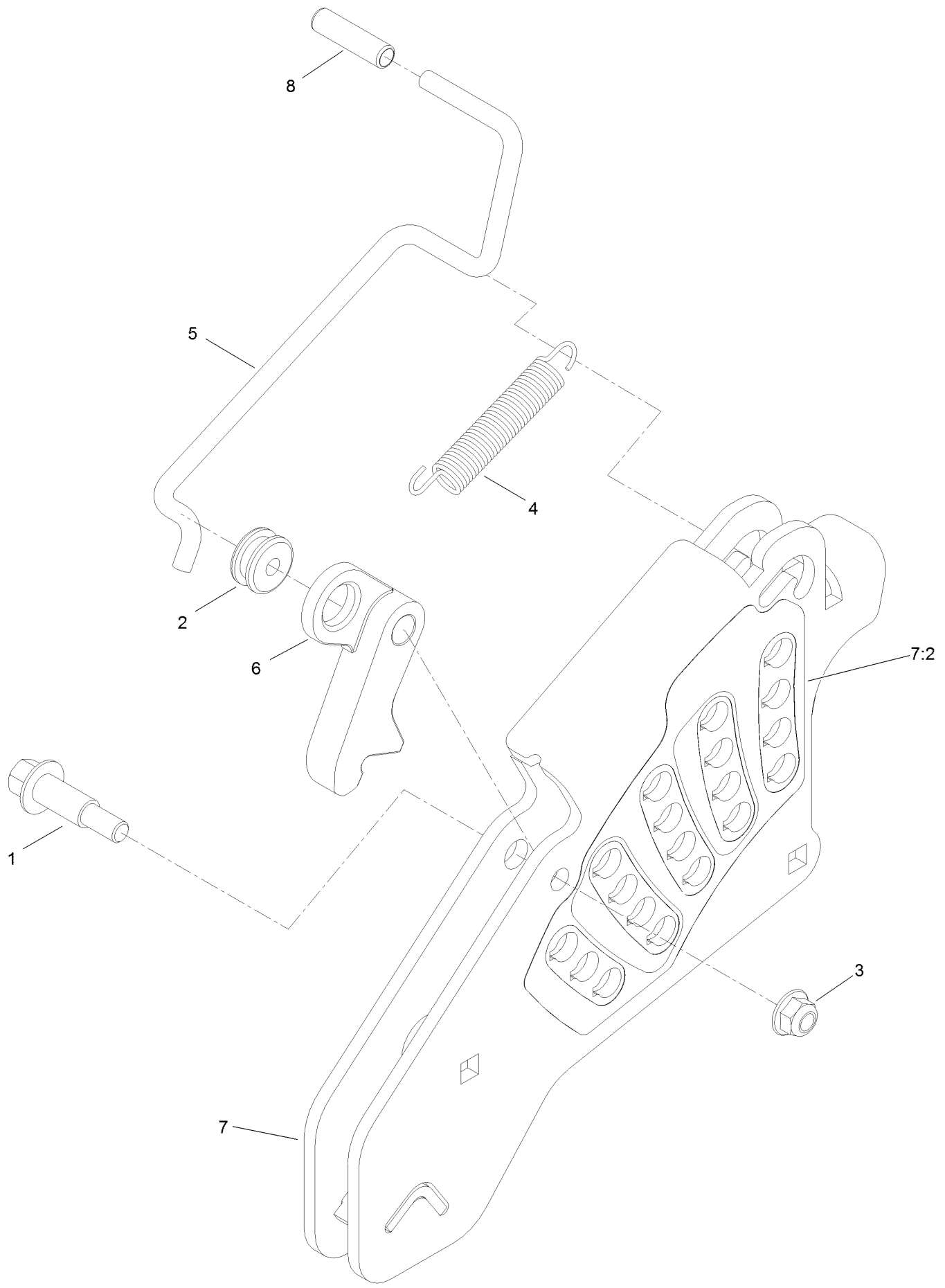

Height-of-Cut Assembly No. 109-7438 (continued)

<i>Ref.</i>	<i>Part Number</i>	<i>Qty.</i>	<i>Description</i>	<i>Ref.</i>	<i>Part Number</i>	<i>Qty.</i>	<i>Description</i>
1	62-1330	1	Bolt-Shoulder	6	116-0118	1	Pawl-Transport, HOC
2	109-7130	1	Grommet	7	109-7335	1	HOC Plate ASM
3	104-8301	1	Nut-HF, NI	7:2	126-4398	1	Decal-HOC
4	109-7124	1	Spring-Extension	8	109-8250	1	Grip-Lever
5	109-7128	1	Rod-Lock, Transport				

Controls Assembly

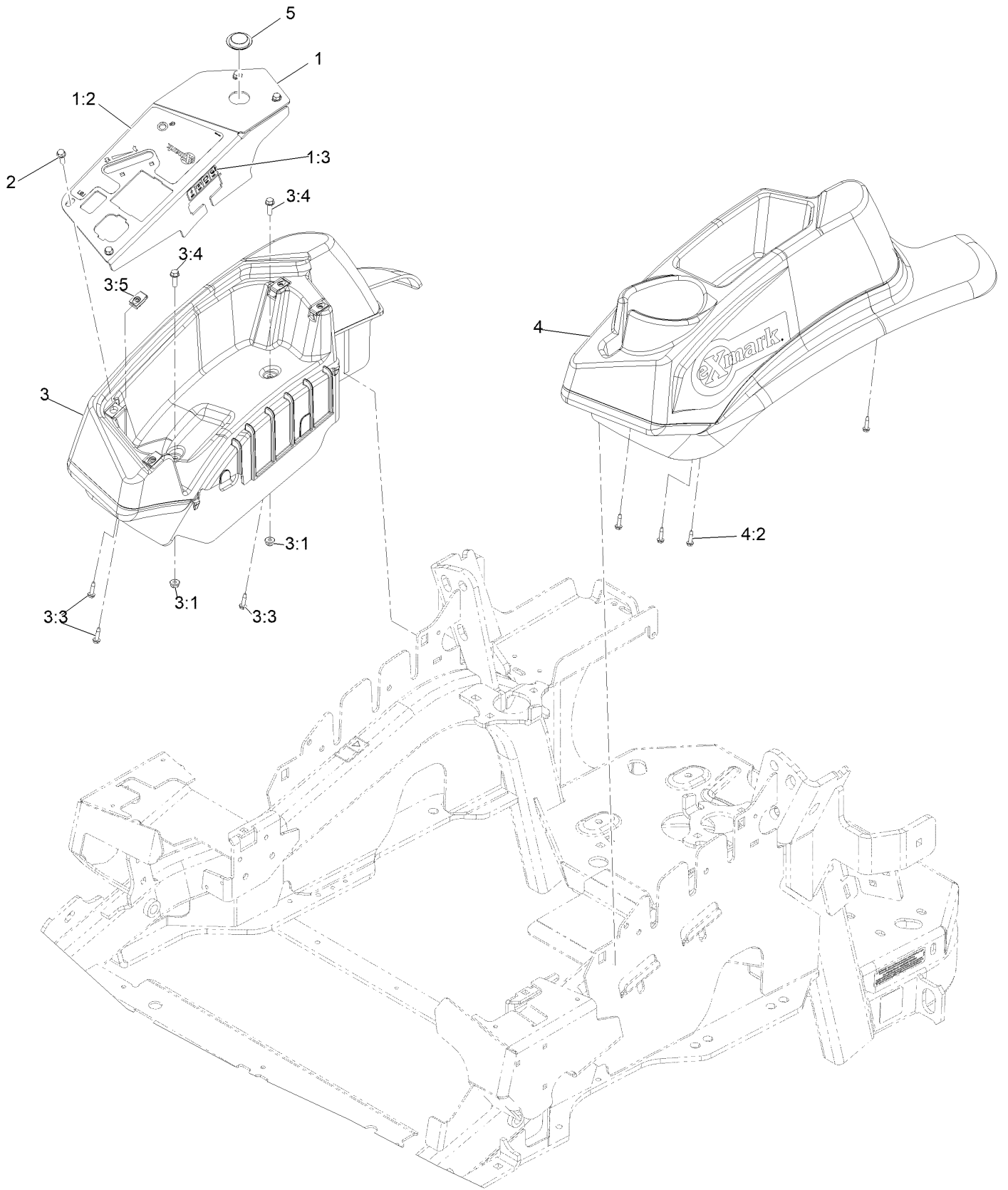

Controls Assembly (continued)

<i>Ref.</i>	<i>Part Number</i>	<i>Qty.</i>	<i>Description</i>	<i>Ref.</i>	<i>Part Number</i>	<i>Qty.</i>	<i>Description</i>
1	116-2845	1	ASM,Control Panel W/Decal	3:3	109-9345	3	Screw-HWH #10-14 X 3/4 Tf
1:2	116-8725	1	Decal-Control Panel EFI	3:4	32105-15	2	Screw-Machine 1/4-20 X 3/4
1:3	114-4466	1	Decal-Fuses	3:5	107069	4	Nut-Retainer-Panel 1/4-20
2	32105-15	4	Screw-Machine 1/4-20 X 3/4	4	109-9342	1	Console.LH Narrow ASM
3	109-9341	1	Console,RH Narrow ASM	4:2	109-9345	4	Screw-HWH #10-14 X 3/4 Tf
3:1	104-7201	2	Nut-Nyloc 1/4-20 Flg	5	116-1875	1	Plug-Plastic

Motion Control Assembly

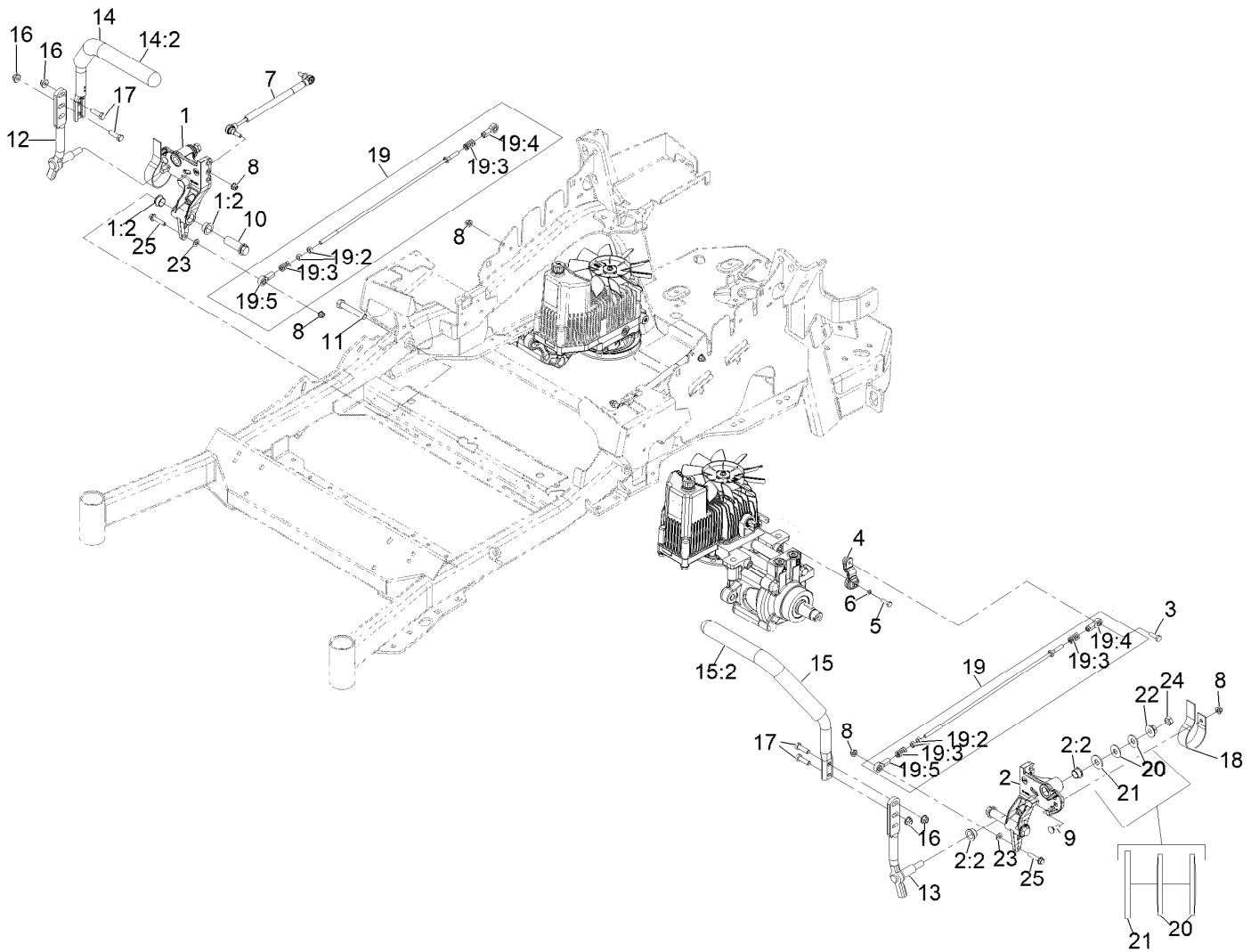

Motion Control Assembly (continued)

<i>Ref.</i>	<i>Part Number</i>	<i>Qty.</i>	<i>Description</i>	<i>Ref.</i>	<i>Part Number</i>	<i>Qty.</i>	<i>Description</i>
1	116-0880	1	RH Motion Control And Bushing ASM	14:2	109-5668	1	Grip-Lever, Control
1:2	109-8054	4	Bushing-Flanged	15	135-4373	1	LH Handle ASM
2	116-0881	1	LH Motion Control And Bushing ASM	15:2	109-5668	1	Grip-Lever, Control
2:2	109-8054	4	Bushing-Flanged	16	104-8301	4	Nut-Nyloc 3/8-16 Flg
3	116-0648	2	Screw-HH 5/16-18 X 1 W/Patch ●	17	323-7	4	Screw-HH 3/8-16 X 1 1/4
4	109-4581	2	Arm-Control, Pump	18	109-5575	2	Spring-Leaf
5	9080046	2	Screw-HH 1/4-20 X 7/8 ●	19	109-8106	2	Front Pump Linkage ASM
6	1-303435	2	Washer-Spring Disc 1/4	19:2	3219-2	2	Nut-Hex 5/16-24
7	116-0027	2	Damper-Control, Motion	19:3	1-323245	2	Spring-Compression
8	104-8300	8	Nut-Nyloc 5/16-18 Flg	19:4	1-633152	1	Balljoint
9	3230-2	2	Bolt-Carriage 5/16-18 X 1	19:5	1-543017	1	Balljoint
10	109-5891	2	Hub-Threaded	20	109-9505	4	Washer, Spring Disc 1/2
11	325-12	2	Screw-HH 1/2-13 X 3	21	3256-6	2	Washer
12	116-0039	1	Lever-Control Motion, RH	22	32128-56	2	Nut-Hex 1/2-13 Flange
13	116-0040	1	Lever-Control Motion, LH	23	3256-23	2	Washer-5/16 SAE
14	135-4371	1	RH Handle ASM	24	3218-5	2	Nut-Jam 1/2-13
				25	115-1794	2	Screw-Hex Flange 5/16-18 X 1 1/2

● Use Pro-Lock, Nut Type (P/N 1-840022, .5ml tube) on threads.

Rear Wheel Assembly

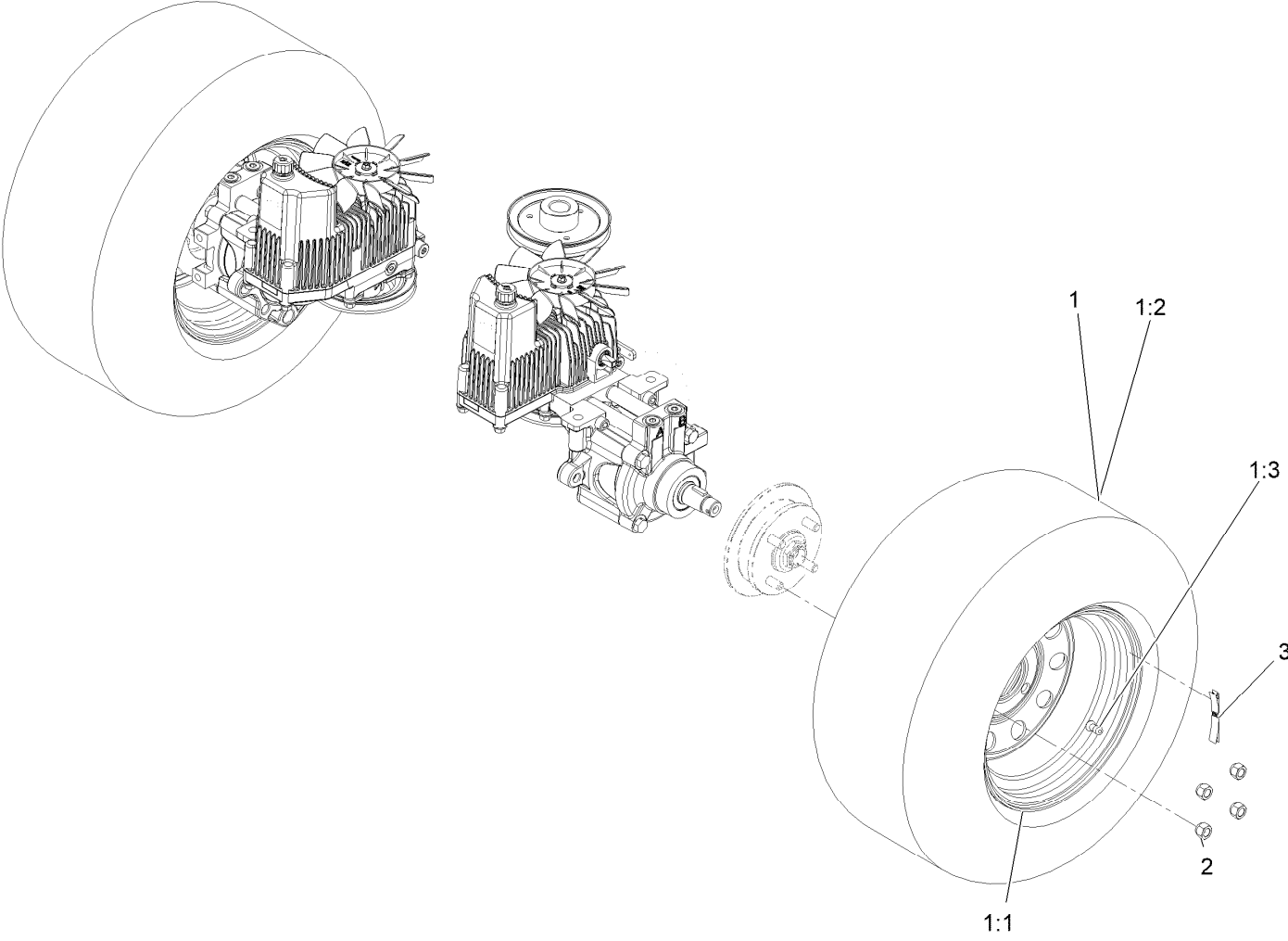

Rear Wheel Assembly (continued)

<i>Ref.</i>	<i>Part Number</i>	<i>Qty.</i>	<i>Description</i>	<i>Ref.</i>	<i>Part Number</i>	<i>Qty.</i>	<i>Description</i>
1	115-3588	2	Wheel And Tire ASM	2	242-50	8	Nut-Lug 1/2-20
1:1	109-2871	1	Rim	3	126-2055	2	Decal-Torque, Wheel Hub Lug
1:2	1-633993	1	Tire				
1:3	232-27	1	Stem-Valve				

Park Brake Assembly

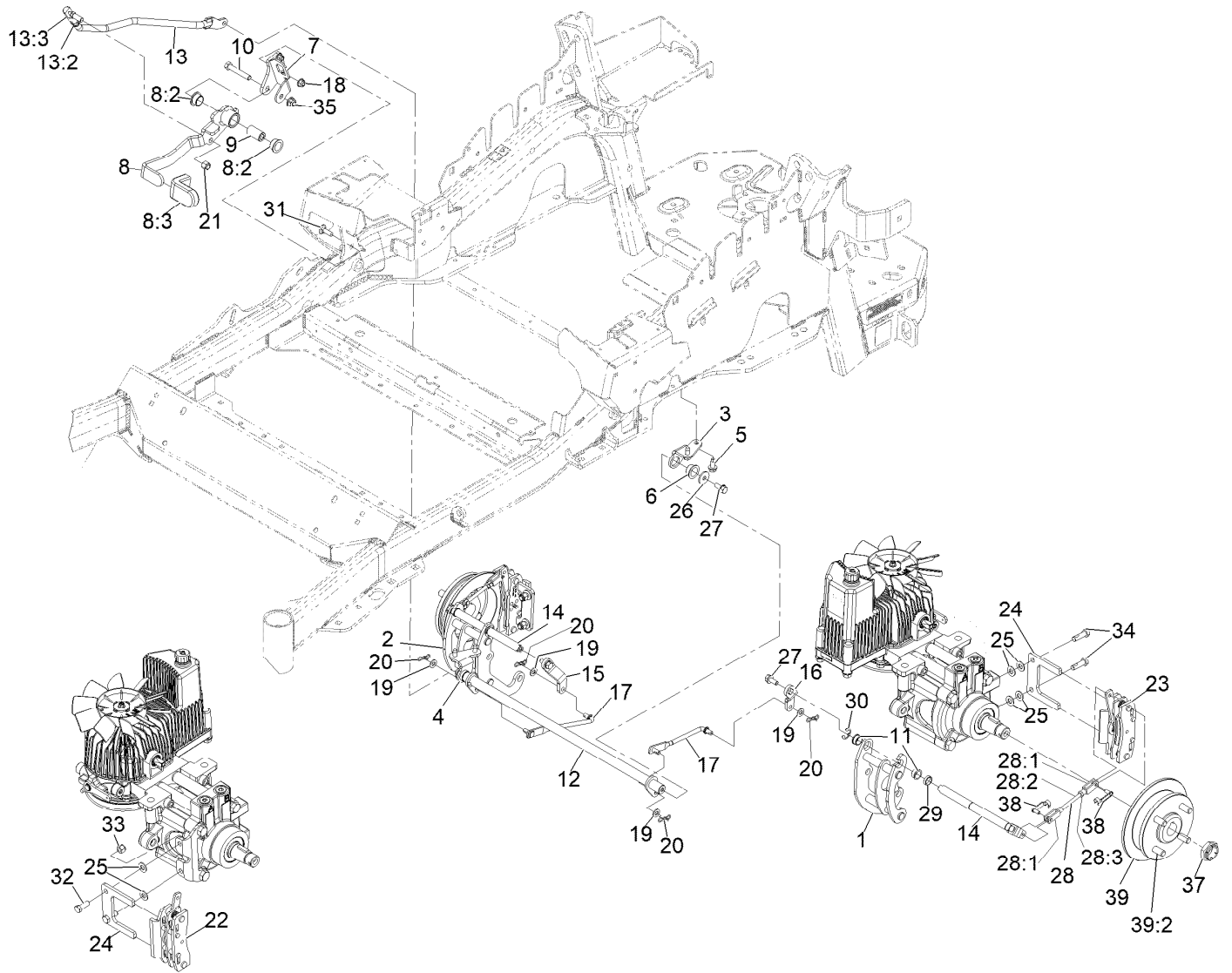

REAR VIEW OF
RIGHT HAND HYDRO

Park Brake Assembly (continued)

<i>Ref.</i>	<i>Part Number</i>	<i>Qty.</i>	<i>Description</i>	<i>Ref.</i>	<i>Part Number</i>	<i>Qty.</i>	<i>Description</i>
1	126-4248	1	Mount-Bellcrank, LH	20	119-1415	4	Pin-Cotter, Locking
2	126-4249	1	Mount-Bellcrank, RH	21	3296-6	1	Nut-Nyloc 3/8-24
3	116-9681	1	Mount-Pivot, LH	22	135-7440	1	Caliper-Brake, RH
4	116-9682	1	Mount-Pivot, RH	23	135-7441	1	Caliper-Brake, LH
5	32144-70	4	Screw-HWH 5/16-18 X 3/4 Tf	24	135-7828	2	Plate-Mount, Brake
6	109-8054	2	Bushing-Flanged	25	3256-24	6	Washer-3/8 SAE
7	116-9096-01	1	Bracket-Mount	26	115-7109	2	Washer-Flat
8	135-7565	1	Brake Lever ASM	27	98-9940	4	Screw-HHF
8:2	109-8054	2	Bushing-Flanged	28	126-7587	2	Rear Linkage ASM
8:3	132-4749	1	Grip-Lever	28:1	126-7588	2	Yoke
9	116-9117	1	Pivot-Handle, Brake	28:2	116-9069	1	Linkage, Rear
10	323-11	1	Screw-HH 3/8-16 X 2 1/4	28:3	3220-1	1	Nut-Jam 1/4-28
11	126-6199	4	Bushing	29	126-6200	2	Spacer
12	135-7800	1	Shaft-Cross	30	32120-19	2	E-Ring
13	135-7805	1	ASM, Front Linkage	31	3230-2	2	Bolt-Carriage 5/16-18 X 1
13:2	94-7572	1	End-Tie Rod, RH	32	135-7915	2	Screw-HH,
13:3	3220-3	1	Nut-Jam 3/8-24	33	112-0236	2	Nut-Lock
14	126-4251	2	Bellcrank	34	135-7890	2	Screw-HH, Patch,
15	126-3716	1	Arm-Inner, RH	35	104-8301	1	Nut-Nyloc 3/8-16 Flg
16	126-3715	1	Arm-Inner, LH	37	116-1399	2	Locknut
17	142-6328	2	Mid-Link, Short	38	126-6395	4	Pin-Clevis, Spring
18	104-8300	2	Nut-Nyloc 5/16-18 Flg	39	142-2701	2	Wheel Hub ASM
19	3256-23	4	Washer-5/16 SAE	39:2	116-1696	4	Stud-Wheel

Seat Assembly

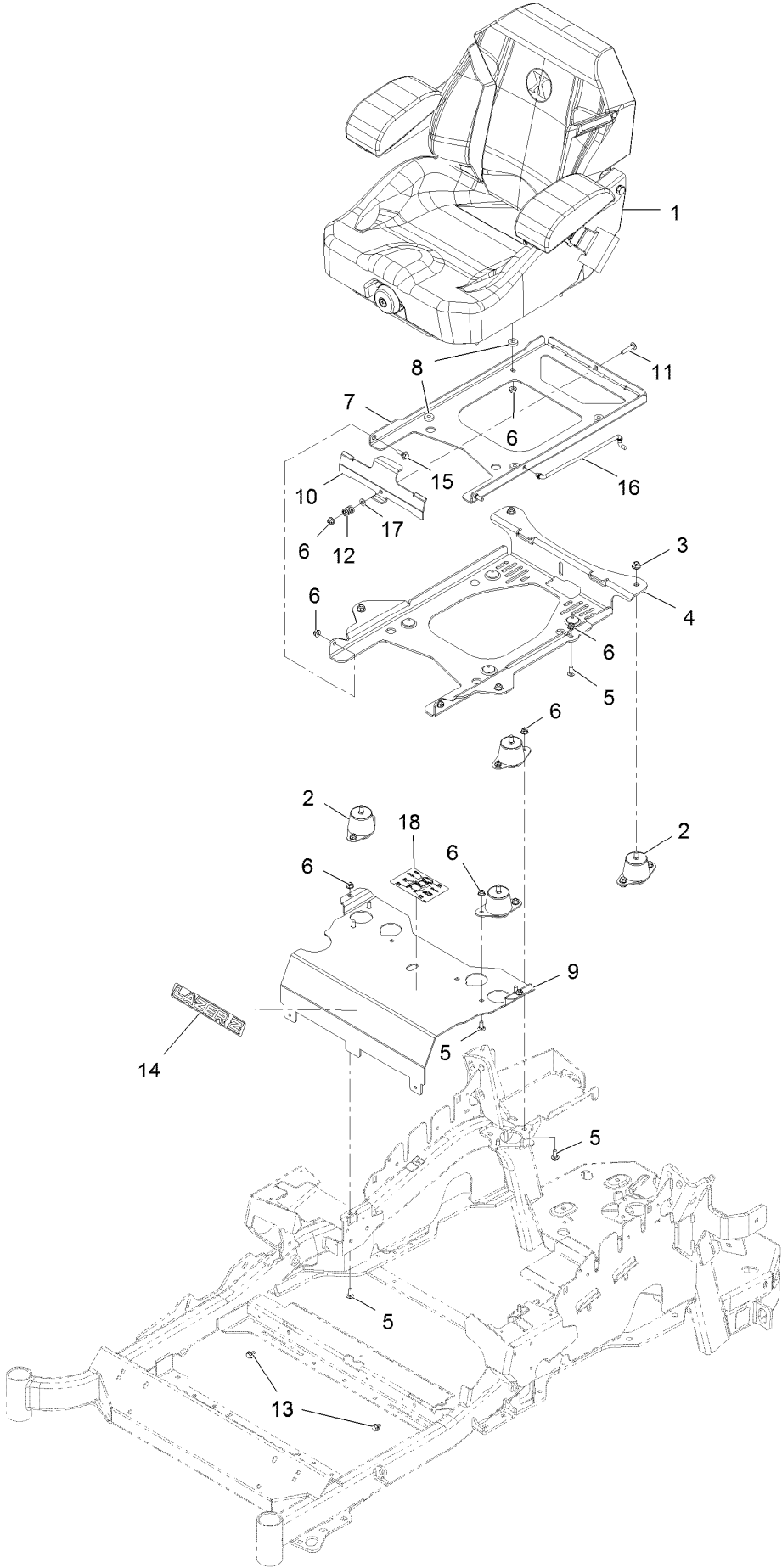

Seat Assembly (continued)

<i>Ref.</i>	<i>Part Number</i>	<i>Qty.</i>	<i>Description</i>	<i>Ref.</i>	<i>Part Number</i>	<i>Qty.</i>	<i>Description</i>
1	116-8912	1	Kit-Suspension Seat	10	109-9881-03	1	Plate-Latch, Seat
2	109-9034	4	Isolator-Seat	11	3230-4	1	Bolt-Carriage 5/16-18 X 1 1/2
3	104-8301	4	Nut-Nyloc 3/8-16 Flg	12	107-3017	1	Spring-Compression
4	116-3860-03	1	Plate-Tilt, Seat Support	13	9266934	2	Screw-HWH 5/16 X 1/2 Tf
5	3230-23	11	Bolt-Carriage 5/16-18 X 3/4 Short Neck	14	126-6574	1	Decal, Lazer Model
6	104-8300	18	Nut-Nyloc 5/16-18 Flg	15	116-1297	2	Screw-Shoulder
7	116-3859-03	1	Plate-Frame, Seat	16	116-0070	1	Rod-Prop
8	26-4840	4	Spacer-Pin, Mounting	17	3256-23	1	Washer-5/16 SAE
9	116-2130-03	1	Panel-Front, Seat Mount	18	114-4465	1	Decal-Service Aid

Seat Assembly (cont.)

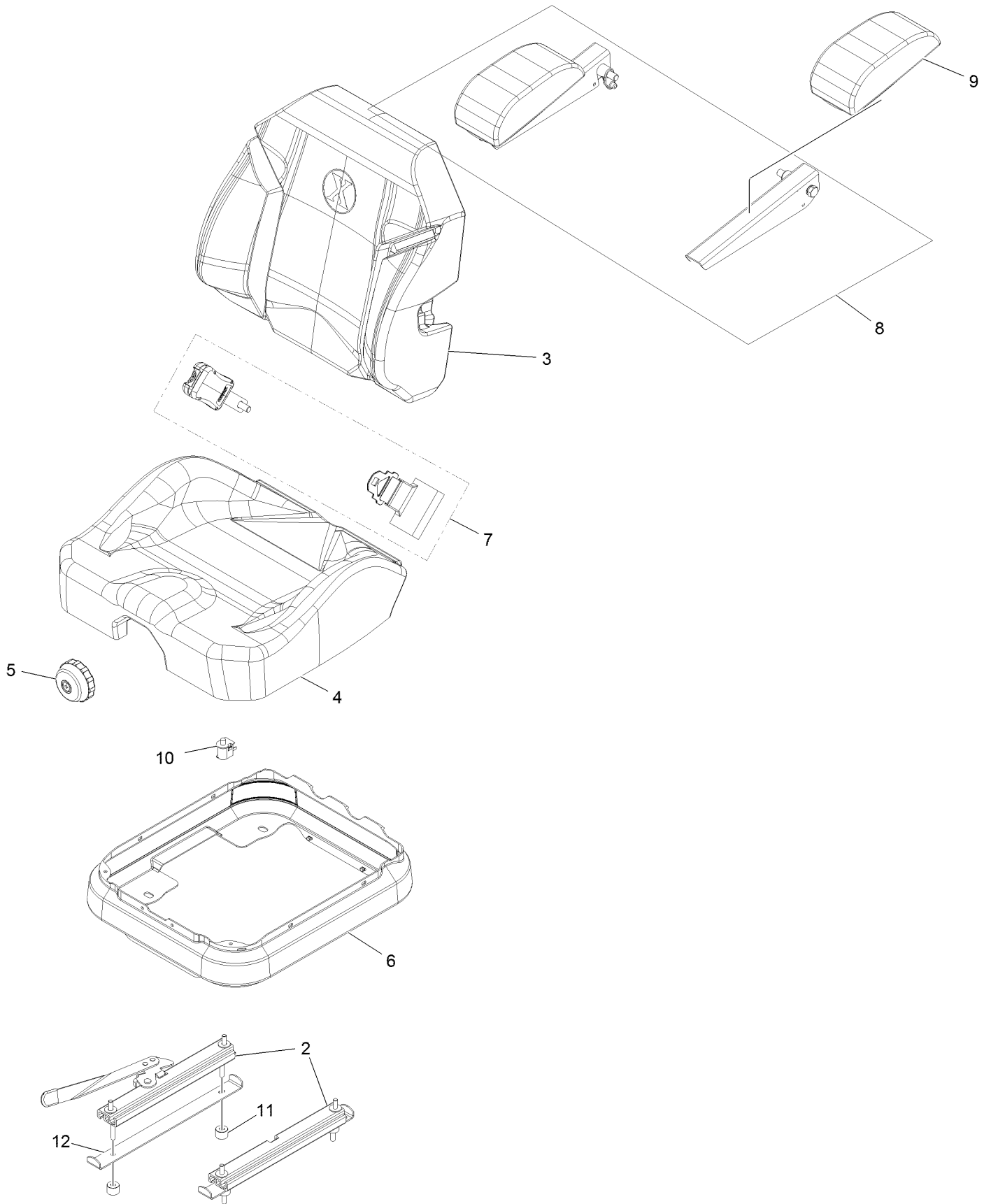

Seat Assembly (cont.) (continued)

<i>Ref.</i>	<i>Part Number</i>	<i>Qty.</i>	<i>Description</i>	<i>Ref.</i>	<i>Part Number</i>	<i>Qty.</i>	<i>Description</i>
2	116-8910	1	Seat Track Set	7	126-2061	1	Seat Belt Service Kit
3	116-8908	1	Cover-Back 311463Vn500	8	116-8906	1	Kit-Arm Rest Set
4	116-8909	1	Cover-Cushion 311464Vn500	9	116-8905	1	Kit-Arm Rest Pads
5	116-8911	1	Knob-Adjuster	10	82-2190	1	Switch
6	116-5659	1	Cover-Suspension Bellows	11	116-9329	4	Spacer
				12	126-9918-03	2	Stop, Seat ●

● Used on Diesel models only

Fuel Assembly

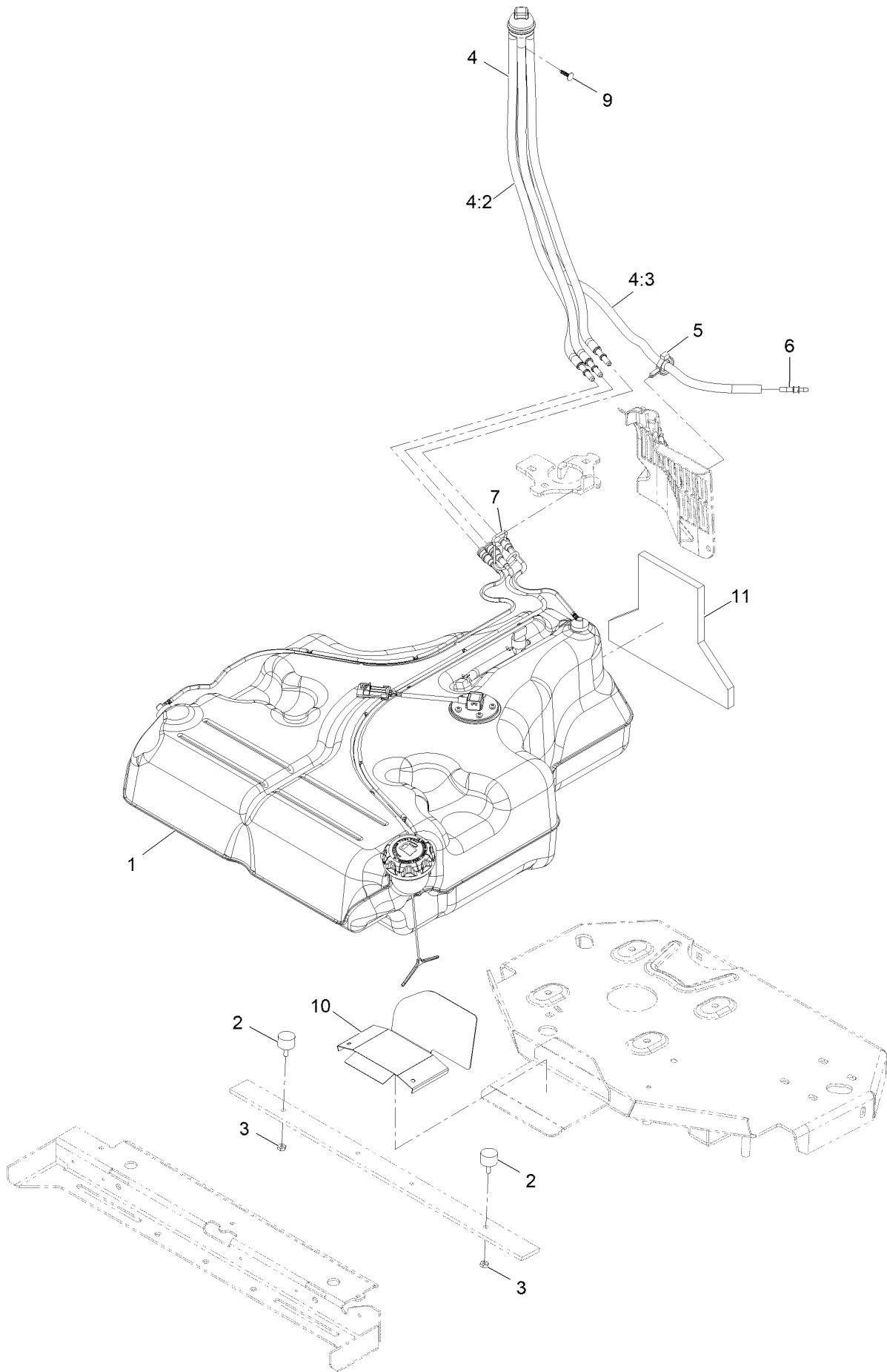

Fuel Assembly (continued)

<i>Ref.</i>	<i>Part Number</i>	<i>Qty.</i>	<i>Description</i>	<i>Ref.</i>	<i>Part Number</i>	<i>Qty.</i>	<i>Description</i>
1	135-0643	1	Fuel Tank ASM	5	105-1853	1	Clamp-Hose
2	1-523420	2	Bumper	6	135-5678	1	Barb-Fuel
3	3218-1	2	Nut-Jam 1/4-20	7	116-6005	1	Retainer-Line, Vapor
4	127-0583	1	Fuel Manifold Vent ASM	9	125-8067	1	Plug-Plastic
4:2	109-0302	3	Hose-Fuel Line 24"	10	126-0032-01	1	Guard-Exhaust
4:3	108-5376	1	Hose-Fuel	11	126-0224	1	Insulation-Foam, Fuel Tank

Fuel Tank Assembly

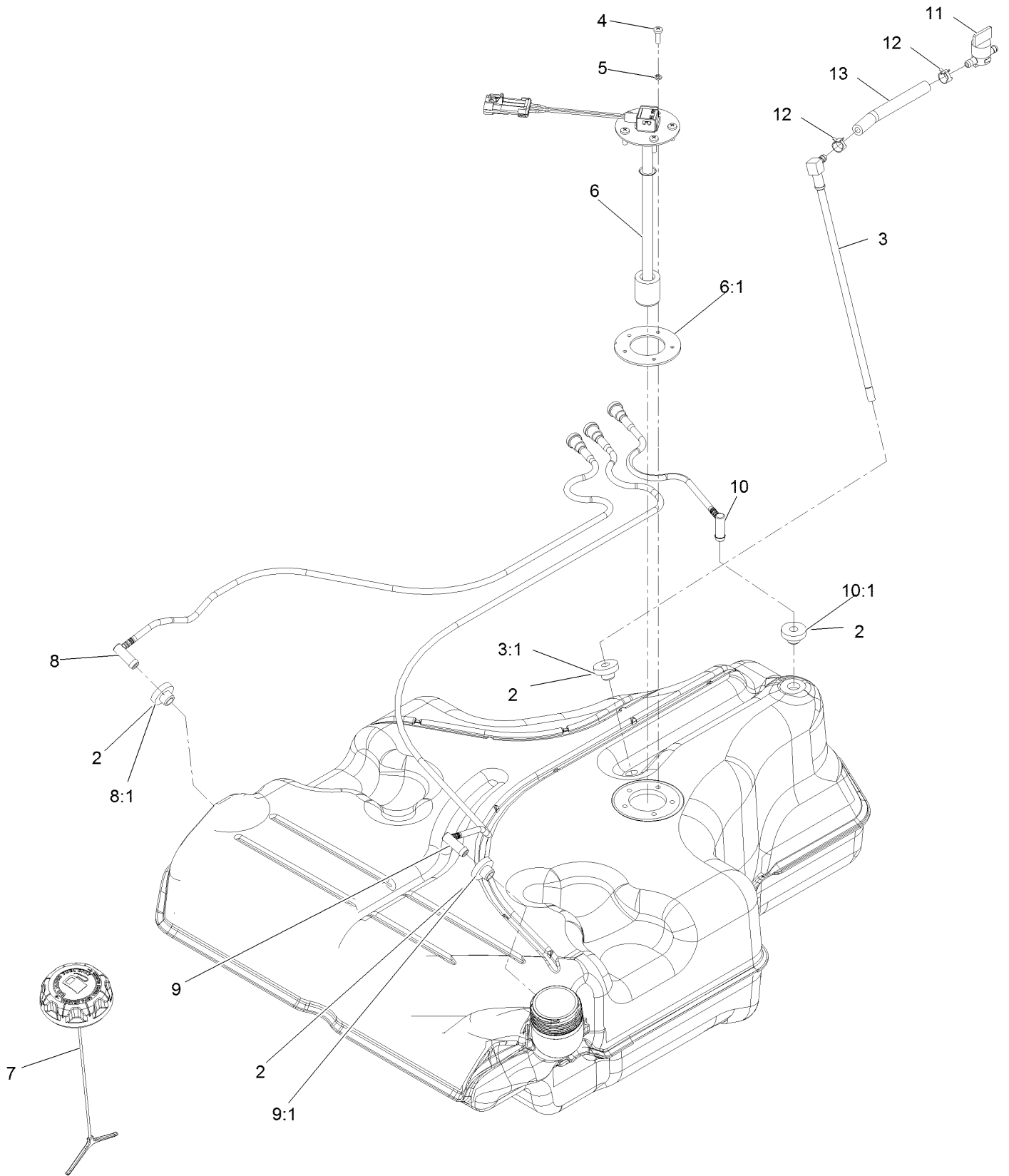

Fuel Tank Assembly (continued)

<i>Ref.</i>	<i>Part Number</i>	<i>Qty.</i>	<i>Description</i>	<i>Ref.</i>	<i>Part Number</i>	<i>Qty.</i>	<i>Description</i>
2	46-6560	4	Bushing	8:1	46-6560	1	Bushing
3	116-2459	1	Fuel Line Kit (With Grommet)	9	116-2461	1	LH Vent Line Kit (With Grommet)
3:1	46-6560	1	Bushing	9:1	46-6560	1	Bushing
4	3290-500	5	Screw-PPH #10-24 X 5/8	10	116-2462	1	Rear Vent Line Kit (With Grommet)
5	3253-17	5	Washer-Lock 3/16	10:1	46-6560	1	Bushing
6	126-3949	1	Sender-Level, Fuel (W/Gasket)	11	1-603770	1	Valve-Fuel
6:1	126-3950	1	Gasket-Sender	12	2412-98	2	Clamp-Hose
7	126-1789	1	Cap-Fuel, Ratcheting	13	109-0650	1	Hose-Fuel
8	116-2460	1	RH Vent Line Kit (With Grommet)				

Engine Assembly

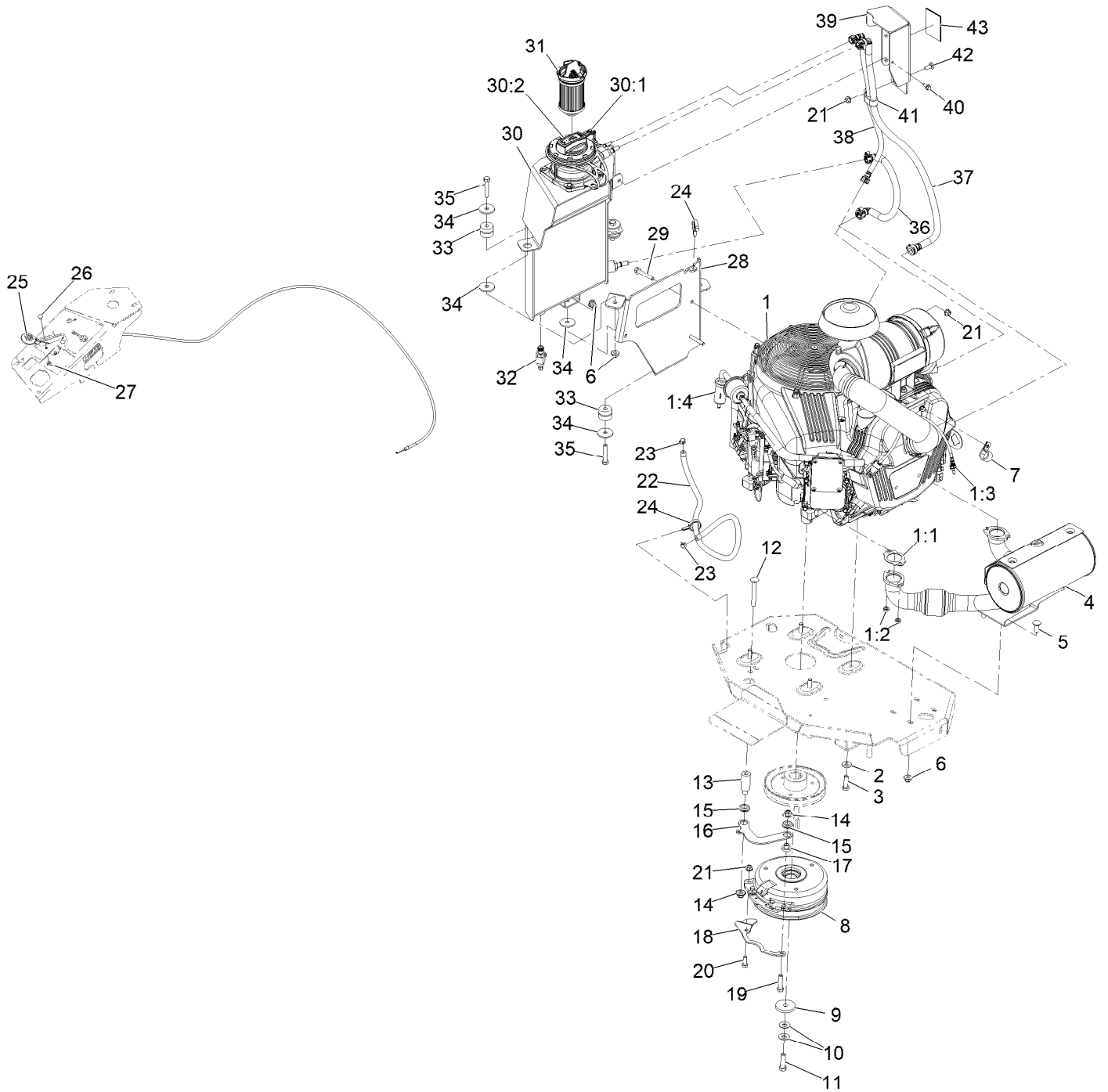

Engine Assembly (continued)

<i>Ref.</i>	<i>Part Number</i>	<i>Qty.</i>	<i>Description</i>	<i>Ref.</i>	<i>Part Number</i>	<i>Qty.</i>	<i>Description</i>
1		1	Engine-Vanguard ●	22	109-3491	1	Hose-Fuel Line 30"
1:1	142-6842	2	Gasket-Exhaust	23	2412-98	2	Clamp-Hose
1:2	33014-00	4	Nut-Hex M8-1.25	24	105-1853	2	Clamp-Hose
1:3	142-6844	1	Sensor-O2	25	116-1972	1	ASM,Throttle Cable
1:4	142-7451	1	Filter-Fuel	26	1-807513	2	Bolt-Carriage #10-24 X 1/2
2	98-5975	4	Washer-Spring Disc 3/8	27	3296-2	2	Nut-Nyloc #10-24
3	323-7	4	Screw-HH 3/8-16 X 1 1/4	28	142-6608-03	1	Mount-Tank, Oil
4	142-5876	1	Muffler	29	142-6275	2	Screw-HHF
5	3231-22	4	Bolt-Carriage 3/8-16 X 1	30	142-6840	1	Reservoir-Oil
6	104-8301	7	Nut-Nyloc 3/8-16 Flg	30:1	142-7452	1	Oil Dipstick ASM
7	110-0824	1	R-Clamp	30:2	142-7453	1	Oil Tank Cap ASM
8	126-4185	1	Clutch Kit	31	142-6841	1	Filter-Oil
9	109-6919	1	Washer-Clutch	32	103-6602	1	Valve-Oil Drain
10	1-603610	2	Washer-Spring Disc 7/16	33	142-6009	3	Isolator-Tank
11	109-9761	1	Screw-HH 7/16-20 X 1 1/2 W/Loctite	34	1-213069	6	Washer
12	3231-42	1	Bolt-Carriage 3/8-16 X 3	35	323-10	3	Screw-HH 3/8-16 X 2
13	116-3319	1	Spacer	36	142-7420	1	Hose-Supply
14	109-6658	2	Nut-Nyloc 3/8-16 Flg	37	142-7421	1	Hose-Scavenge
15	93-5108	2	Grommet-Rubber	38	142-6393	1	Hose-Vent
16	116-3317-01	1	Link-Anchor, Clutch	39	142-6731-03	1	Guard-Hose
17	116-3318	1	Spacer	40	32144-10	3	Screw-HWH 1/4-20 X .62
18	116-3331-01	1	Belt-Guide	41	120-1959	1	Clamp
19	323-8	1	Screw-HH 3/8-16 X 1 1/2	42	3230-23	1	Bolt-Carriage 5/16-18 X 3/4 Short Neck
20	322-4	1	Screw-HH 5/16-18 X 7/8	43	142-7806	1	Decal-Oil Guard
21	104-8300	4	Nut-Nyloc 5/16-18 Flg				

● Not serviced separately

Hydraulic Assembly

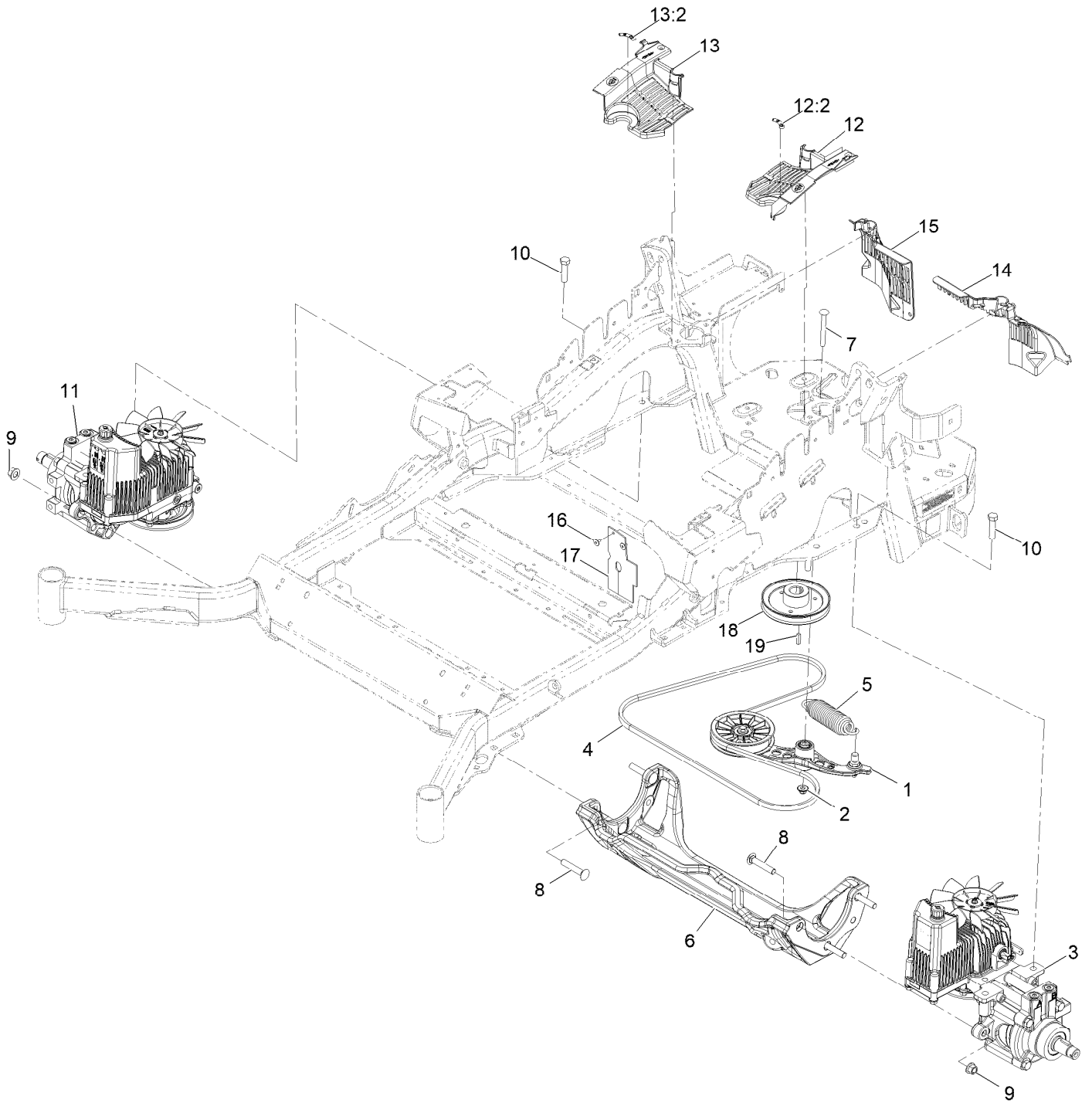

Hydraulic Assembly (continued)

<i>Ref.</i>	<i>Part Number</i>	<i>Qty.</i>	<i>Description</i>	<i>Ref.</i>	<i>Part Number</i>	<i>Qty.</i>	<i>Description</i>
1	116-1255	1	Pump Idler ASM	12:2	116-8726	1	Decal-Oil, Hydro
2	109-6658	1	Nut-Nyloc 3/8-16 Flg	13	116-0171	1	RH Hydro Guard ASM
3	135-7907	1	Hydro-LH	13:2	116-8726	1	Decal-Oil, Hydro
4	126-9835	1	Belt-V	14	142-6499	1	Guard-Hydro, Rear LH
5	116-6317	1	Spring-Extension	15	109-9058	1	Guard-Hydro, Rear (RH)
6	116-7558	1	Cradle-Hydro	16	1-803035	2	Rivet 3/16 X 1/4
7	116-1502	1	Bolt-Carriage Shoulder 3/8-16 X 3 1/2	17	116-2362	1	Deflector-Air Flow
8	126-0095	6	Bolt-Carriage 1/2-13 X 2 3/4	18	109-9905	1	Sheave
9	99-5107	6	Nut-Lock 1/2-13	19	1-807259	1	Key-Machine 1/4 X 1/4 X 1
10	325-8	4	Screw-HH 1/2-13 X 1 1/4	99	109-9828	1	Oil-HYD, (Quart) ●
11	135-7908	1	Hydro-RH	99	116-0164	1	Filter-Hydro ●
12	116-0170	1	LH Hydro Guard ASM	99	116-1218	1	Oil-HYD, 1 Gallon ●
				99	126-8103	1	Kit, Hydro Service ●

● Not illustrated

LH Hydro Assembly No. 135-7907

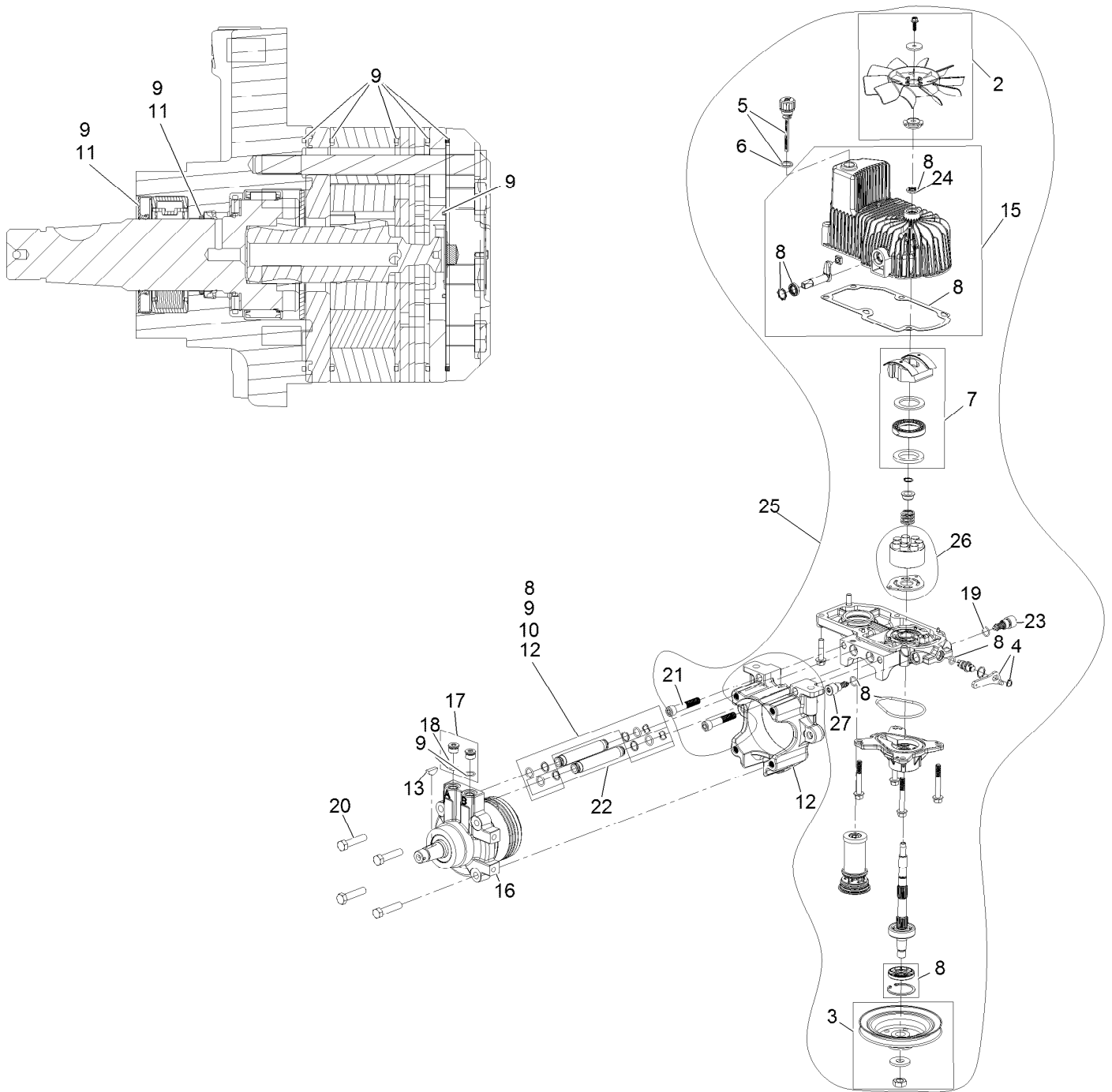

LH Hydro Assembly No. 135-7907 (continued)

<i>Ref.</i>	<i>Part Number</i>	<i>Qty.</i>	<i>Description</i>	<i>Ref.</i>	<i>Part Number</i>	<i>Qty.</i>	<i>Description</i>
2	142-3603	1	Kit, 7.8 In Fan	17	116-7901	1	Magnetic Plugs Service Kit
3	116-0234	1	Pulley Kit	18	76-1900	2	O-Ring
4	116-0235	1	Handle	19	116-8662	2	O-Ring-Valve, Check
5	116-0236	1	Dipstick	20	116-8974	4	Screw-HH 1/2-20 X 2 1/4
6	116-0237	1	Gasket	21	116-8975	2	Screw-HSH 1/2-20 X 2 3/4
7	116-1367	1	Swash Block Kit	22	116-9922	2	Hydraulic Tube Kit
8	142-3604	1	Kit, Pump Seal	23	126-7467	1	Shock Valve, 16Cc Hydro
9	116-1369	1	Motor Seal Kit	24	126-7711	1	Seal-Drive, Fan
10	116-1370	1	Tube Seal Kit	25	142-3607	1	Kit, Pump Section 16Cc LH
11	116-1371	1	Output Shaft Seal Kit	26	142-4501	1	Kit - 16Cc Port Plate, Rotate Grp
12	116-5469	1	Cup-Nose				
13	3257-42	1	Key-Woodruff 5/16 X 1	27	142-4458	1	Shock Valve Orificed 3300
15	142-4460	1	Kit, Housing-Hydro LH	99	116-1373	1	Flow Test Kit ●
16	116-8917	1	Motor-Hydraulic, LH 280Cc				

● Not illustrated

RH Hydro Assembly No. 135-7908

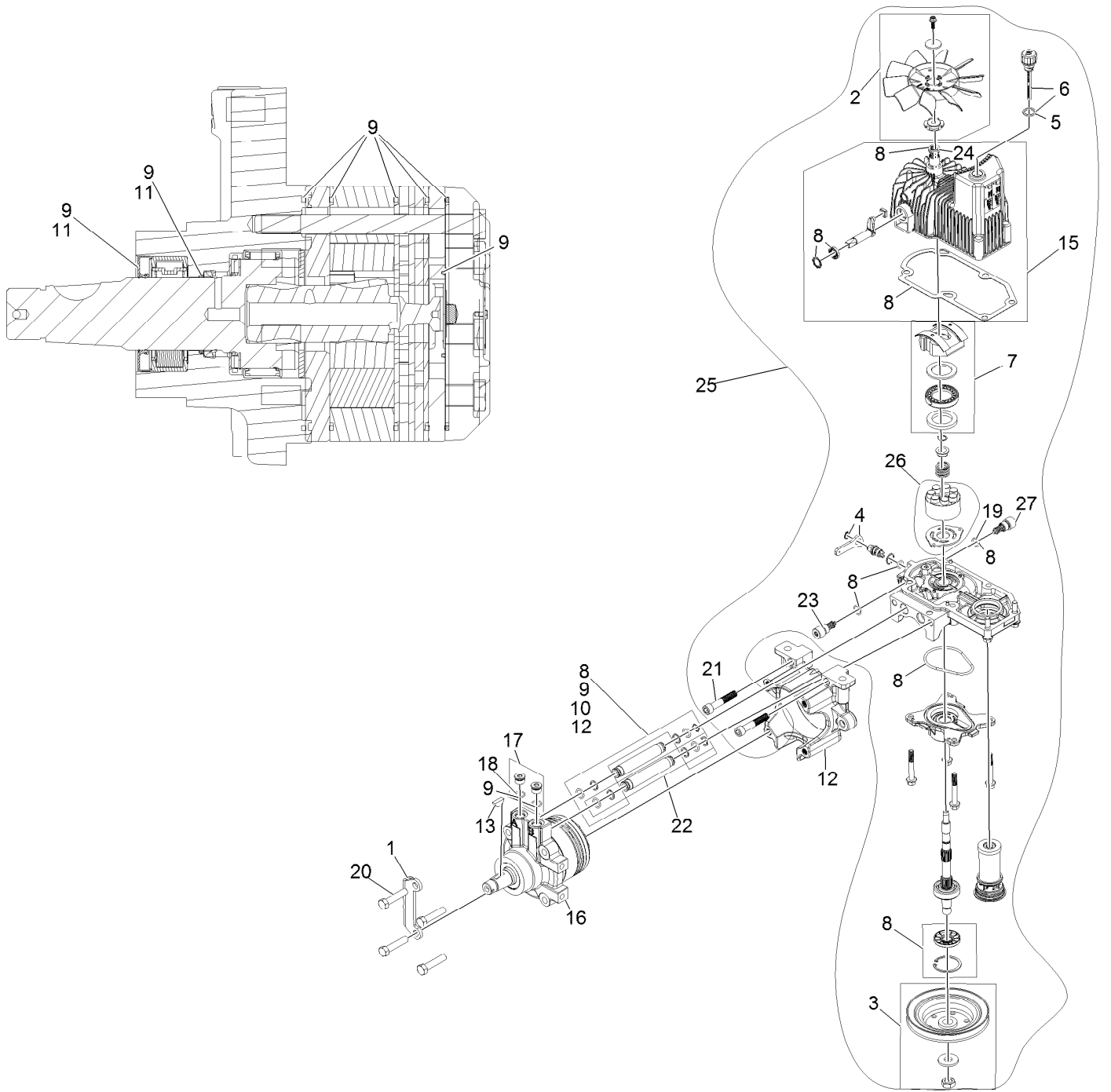

RH Hydro Assembly No. 135-7908 (continued)

<i>Ref.</i>	<i>Part Number</i>	<i>Qty.</i>	<i>Description</i>	<i>Ref.</i>	<i>Part Number</i>	<i>Qty.</i>	<i>Description</i>
1	135-7827	1	Plate, Horse Shoe Mount	17	116-7901	1	Magnetic Plugs Service Kit
2	142-3603	1	Kit, 7.8 In Fan	18	76-1900	2	O-Ring
3	116-0234	1	Pulley Kit	19	116-8662	2	O-Ring-Valve, Check
4	116-0235	1	Handle	20	116-8974	4	Screw HH
5	116-0237	1	Gasket	21	116-8975	2	Screw-HSH
6	116-0236	1	Dipstick	22	116-9922	2	Hydraulic Tube Kit
7	116-1367	1	Swash Block Kit	23	126-7467	1	Shock Valve, 16Cc Hydro
8	142-3604	1	Kit, Pump Seal	24	126-7711	1	Seal-Drive, Fan
9	116-1369	1	Motor Seal Kit	25	142-3606	1	Kit, Pump Section 16Cc RH
10	116-1370	1	Tube Seal Kit	26	142-4501	1	Kit - 16Cc Port Plate, Rotate Grp
11	116-1371	1	Output Shaft Seal Kit				
12	116-5469	1	Cup-Nose	27	142-4458	1	Shock Valve Orificed 3300
13	3257-42	1	Key-Woodruff	99	116-1373	1	Flow Test Kit ●
15	142-4461	1	Kit, Housing-Hydro RH	99	116-4245	1	Puller-Pulley
16	116-8918	1	Motor-Hydraulic, RH 280Cc				

● Not illustrated

Pump Idler Assembly No. 116-1255

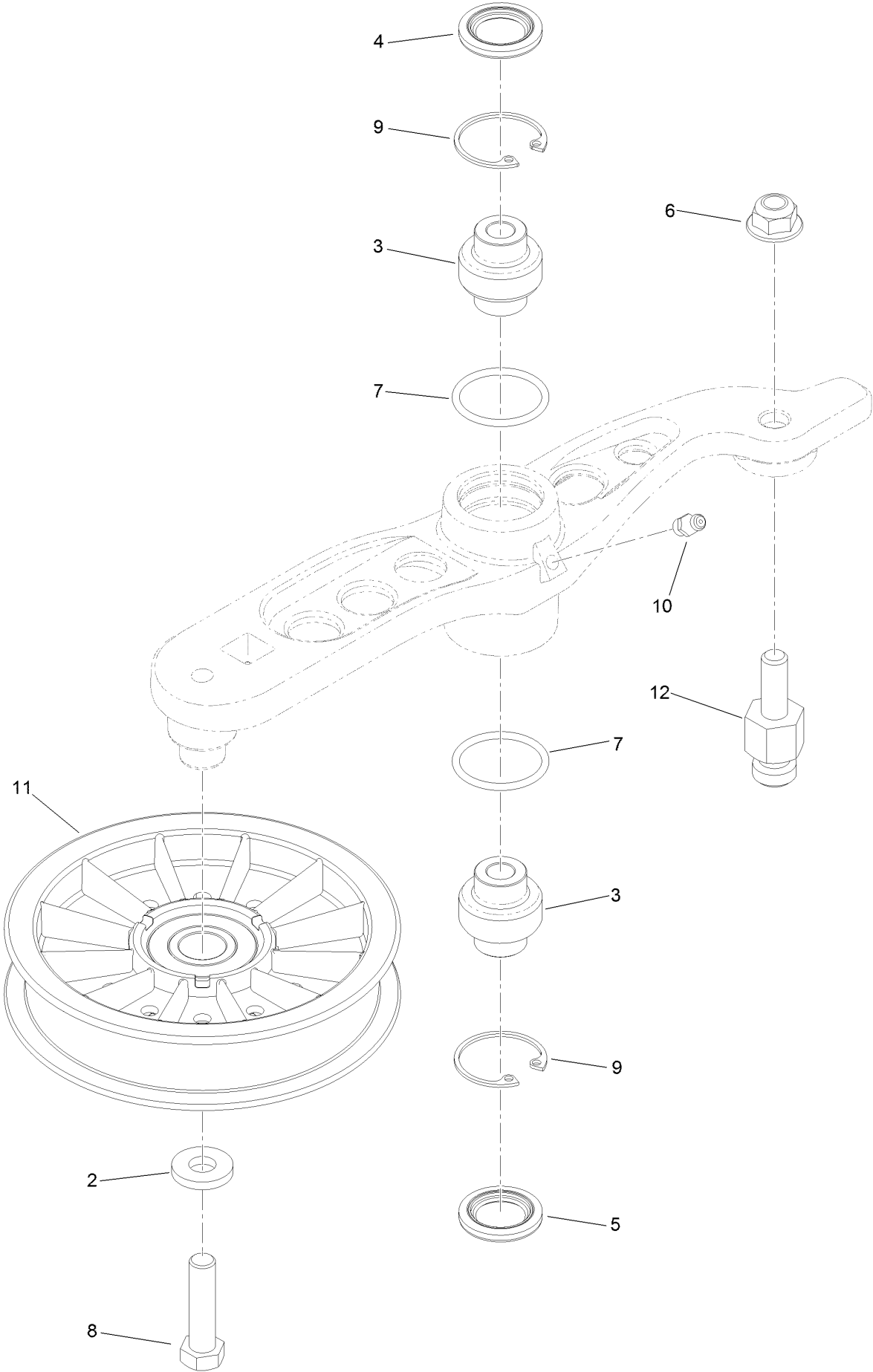

Pump Idler Assembly No. 116-1255 (continued)

<i>Ref.</i>	<i>Part Number</i>	<i>Qty.</i>	<i>Description</i>	<i>Ref.</i>	<i>Part Number</i>	<i>Qty.</i>	<i>Description</i>
2	43-0940	1	Spacer	8	323-8	1	Screw-HH
3	103-3504	2	Bearing-Spherical	9	32120-10	2	Ring-Snap
4	103-3505	1	Seal-Lip, Double	10	302-19	1	Fitting-Grease
5	103-3506	1	Seal-Lip, Single	11	109-8076	1	Pulley-Idler
6	109-6658	1	Nut-Flange, NI	12	132-4724	1	Pin-Anchor, Spring
7	106-7159	2	O-Ring				

Electrical Assembly

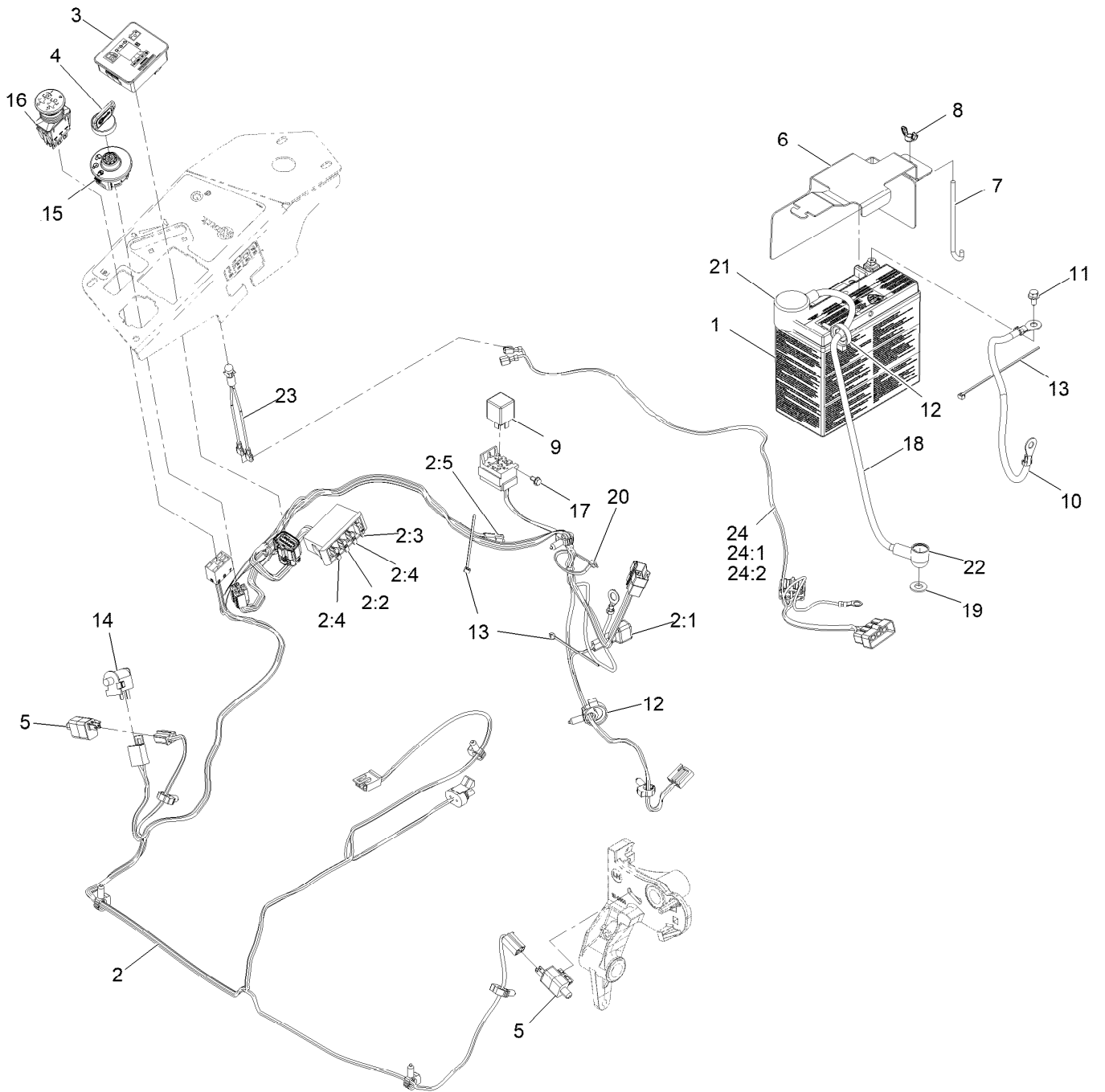

Electrical Assembly (continued)

<i>Ref.</i>	<i>Part Number</i>	<i>Qty.</i>	<i>Description</i>	<i>Ref.</i>	<i>Part Number</i>	<i>Qty.</i>	<i>Description</i>
1	142-7427	1	Battery-Agm	13	1-303287	3	Tie-Cable 5 1/2 (Small)
2	116-6009	1	Harness-Wire, Main ■	14	82-2190	1	Switch
2:1	103-3895	1	Diode	15	137-4100	1	Switch-Ignition
2:2	218-578	1	Fuse-Blade, 10 Amp	16	135-3653	1	Switch, PTO 10A
2:3	109355	1	Fuse-Blade, 15 Amp	17	104-2065	1	Screw-HWH #10-24 X 3/8
2:4	109102	2	Fuse-Blade, 25 Amp	18	115-3864	1	Cable-Battery, Positive
2:5	116-0053	1	Cap-Plug	19	3256-24	1	Washer-3/8 SAE
3	117-3882	1	Fuel/Hour Meter ASM	20	3290-378	1	Tie-Cable
4	1-603511	1	Key-Ignition	21	109-2407	1	Insulator-Battery
4	103-2106	1	Key-Exmark Logo	22	1-543393	1	Insulator-Solenoid
5	110-6765	2	Switch	23	1-643267	1	Indicator-Red LED
6	142-6707-03	1	Bracket-Holddown, Battery	24	142-6440	1	Harness-Indicator Light
7	142-6406	1	Bolt-Holddown	24:1	32180-209	1	Tubing, Conv, 1/4", Hi Temp, Uv Inhibit
8	1-543792	1	Wingnut-Nyloc 1/4-20	24:2	32180-211	1	Tubing, Conv, 7/16", Hi Temp, Uv Inhibit
9	1-643275	1	Relay-12Vdc 40 Amp	99	142-7682	1	Hardware Kit, Battery ●
10	112-7063	1	Cable-Battery, Black				
11	126-2713	2	Screw-HHF				
12	105-1853	2	Clamp-Hose				

● Not illustrated

■ Use dielectric grease on all unsealed connectors and terminals only. Do not apply in sealed connectors.

Notes:

Notes:

Notes:



MAXIMIZE THE PERFORMANCE OF YOUR EXMARK MACHINE.



EXMARK® PREMIUM ENGINE OIL

Exmark now offers a family of engine oil viscosities to perform well in any environment. Each viscosity has the same synthetic formulation to give you what you need in punishing conditions. We designed each grade to the highest quality, making it ideal even for diesel applications. Coupled with Exmark Premium Fuel Treatment, we have the performance products to make your machine hum.

EXMARK PREMIUM ENGINE OIL SAE 30/10W-30

- Meets zero shear requirements of a straight grade SAE 30 as well as the cold temp properties of a 10W-30.
- Most versatile oil in the industry.
- Superior corrosion protection over conventional oil - even in corrosive, humid environments.

EXMARK PREMIUM ENGINE OIL SAE 20W-50

- Perfect for your big block engine, or any application in severe service.
- Same full synthetic formulation as all other Exmark Premium viscosities.
- Also effective for use in severe service small block engines.

EXMARK PREMIUM ENGINE OIL SAE 10W-50

- Full synthetic formulation gives you peak performance. Don't settle for less.
- Wide span multi-grade combines easy starting in cold weather with maximum protection in high temperature operation.
- Reduce friction & wear over standard mineral formulations.

EXMARK PREMIUM ENGINE OIL SAE 0W-40

- The perfect choice for when the weather turns cold or unpredictable, and your Exmark UTV has to perform.
- Commercial quality for severe service.
- Advanced additive package helps prevent corrosion from long-term storage.

EXMARK PREMIUM ENGINE OIL UTV FORMULATION

- 4-cycle high-temp formulation.
- Heavier viscosity, full synthetic, perfect for your UTV.

EXMARK PREMIUM UTV EXTREME CONDITIONS GEAR OIL

- SAE 80W-90, designed to keep your UTV performing at its peak.
- Shear stable, hypoid gear lube.
- Includes a premium additive system to combat wear, oxidation, rust & corrosion.

Available from your local Exmark dealer. Find your closest dealer at exmark.com

EXMARK ACCESSORIES AND OPTIONS*

MID-MOUNT RIDING ACCESSORIES AND OPTIONS

CUSTOM RIDE SEAT SUSPENSION SYSTEM	OPERATOR CONTROLLED DISCHARGE
FULL SUSPENSION SEAT	SUN SHADE
DECK LIFT ASSIST KIT	TRASH CONTAINER
HITCH KIT	TURF STRIPER
LIGHT KIT	ULTRA VAC COLLECTION SYSTEM
12V POWER PORT	ULTRA VAC QUICK DISPOSAL SYSTEM
MICRO-MULCH SYSTEM	

OUT-FRONT RIDING ACCESSORIES AND OPTIONS

CUSTOM RIDE SEAT SUSPENSION SYSTEM	SNOW BLADE
DUAL-TAIL WHEEL	SNOWBLOWER
FLOOR PAN EXTENDER	SUN SHADE
HITCH KIT	TRASH CONTAINER
LIGHT KIT	ULTRA VAC COLLECTION SYSTEM
MICRO-MULCH SYSTEM	ULTRA VAC QUICK DISPOSAL SYSTEM
ROLL OVER PROTECTION SYSTEM (ROPS)	WEATHER CAB

WALK-BEHIND ACCESSORIES AND OPTIONS

GRASS CATCHER	TURF STRIPER
MICRO-MULCH SYSTEM	STANDON

*Some accessories and options not available for some models.

Place Model No. and Serial No.
Label Here (Included in the Literature
Pack) or Fill in Below

Model No. _____

Serial No. _____

Date Purchased _____

Engine Model No. and Spec. No. _____

Engine Serial No. (E/No) _____

© 2021 Exmark Mfg. Co., Inc.
415 Industrial Row
Beatrice, NE 68310
All Rights Reserved

Part No. 4505-754 Rev. B
(402) 223-6375
Fax (402) 223-5489
Printed in the USA.

