



# LAZER Z<sup>®</sup> X-SERIES

Model No. LZX801CKA726C1—Serial No. 411294212 and Up

Picture below may not reflect actual product.



# Parts Manual

Part No. 4505-751 Rev. A

# Ordering Replacement Parts

To order replacement parts, please supply the part number, the quantity, and the description of each part desired.

## Understanding Reference Numbers

Each identified part in an illustration has a reference number. The reference number for a part also appears in the parts list, along with other information about the part.

This catalog uses two special reference number formats, one to indicate parts in a service assembly and another to indicate the quantity of a given part in an illustration.

## Service Assembly Reference Numbers

Parts in service assemblies have reference numbers in the form a:b. The a represents the reference number of the entire service assembly and the b represents a sequential number unique to each part within the service assembly.

For example, a wheel assembly might be identified by reference number 6, the tire by 6:1, the valve by 6:2, and the wheel by 6:3. When you order the assembly identified by reference number 6, you receive all parts identified by reference numbers 6:1, 6:2, and 6:3. However, you may also order any part individually. Reference numbers of this type appear in illustration and in parts lists.

## Reference Numbers Indicating Quantity

In an illustration, if a reference number indicates more than one part, the reference number has the form nX y. The n represents the quantity of the part, the X is the multiplication symbol, and the y represents the reference number.

For example, in an illustration, the reference number 2X 37 means that two of the parts identified by reference number 37 are indicated.

# Touch Up Paint

Exmark black touch up spray paint – gloss black.

Exmark red touch up paint (spray paint – P/N 1-850337 - .6 oz liquid bottle – P/N 103-9140).

# Contents

|  |    |
|--|----|
| Complete Deck Assembly .....               | 4  |
| Deck Assembly .....                        | 6  |
| Deck W/Decals Assembly No. 116-1665 .....  | 8  |
| Idler Assembly .....                       | 10 |
| Cutter Housing Assembly No. 103-9539 ..... | 12 |
| Full Suspension Assembly .....             | 14 |
| Main Frame Assembly .....                  | 16 |
| X-Series Decal .....                       | 18 |
| Roll-Over Protection System .....          | 20 |
| Roll Over Protection System (cont.) .....  | 22 |
| Front Caster and Fork Assembly .....       | 24 |
| Caster Wheel and Fork Assembly .....       | 26 |
| Deck Lift Assembly .....                   | 28 |
| Height-of-Cut Assembly No. 109-7438 .....  | 30 |
| Controls Assembly .....                    | 32 |
| Motion Controls Assembly .....             | 34 |
| Rear Wheel Assembly .....                  | 36 |
| Park Brake Assembly .....                  | 38 |
| Suspension Seat Assembly .....             | 40 |
| Seat W/Tracks Assembly No. 126-5801 .....  | 42 |
| Fuel System Assembly .....                 | 44 |
| Fuel Tank Assembly .....                   | 46 |
| Engine Assembly .....                      | 48 |
| Hydraulic Assembly .....                   | 50 |
| LH Hydro Assembly No. 135-7905 .....       | 52 |
| RH Hydro Assembly No. 135-7906 .....       | 54 |
| Pump Idler Assembly No. 116-1255 .....     | 56 |
| Electrical Assembly .....                  | 58 |

# Complete Deck Assembly

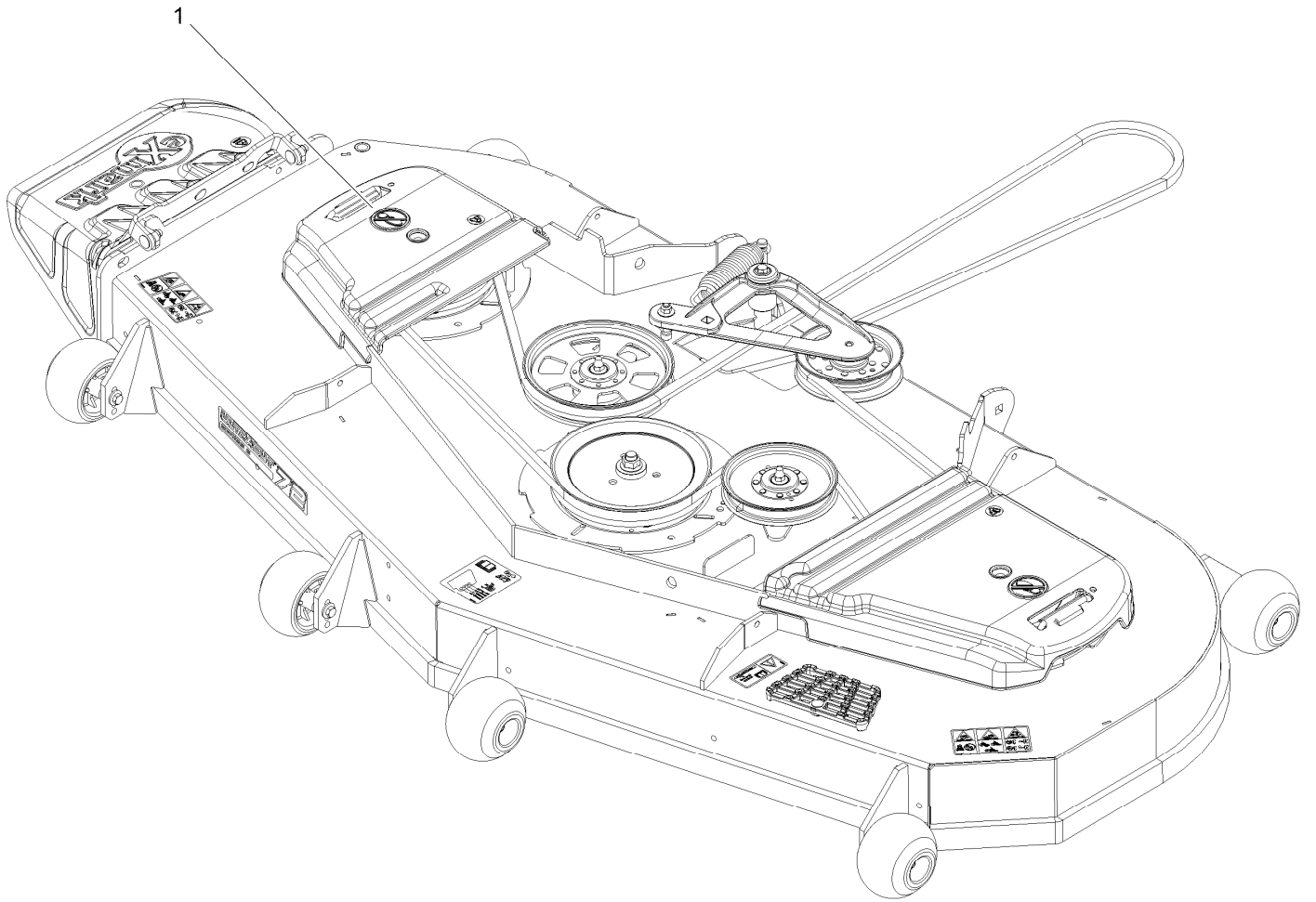

# Complete Deck Assembly (continued)

| <i>Ref.</i> | <i>Part Number</i> | <i>Qty.</i> | <i>Description</i>    |
|-------------|--------------------|-------------|-----------------------|
| 1           | 109-9649           | 1           | Complete Deck ASM-726 |

# Deck Assembly

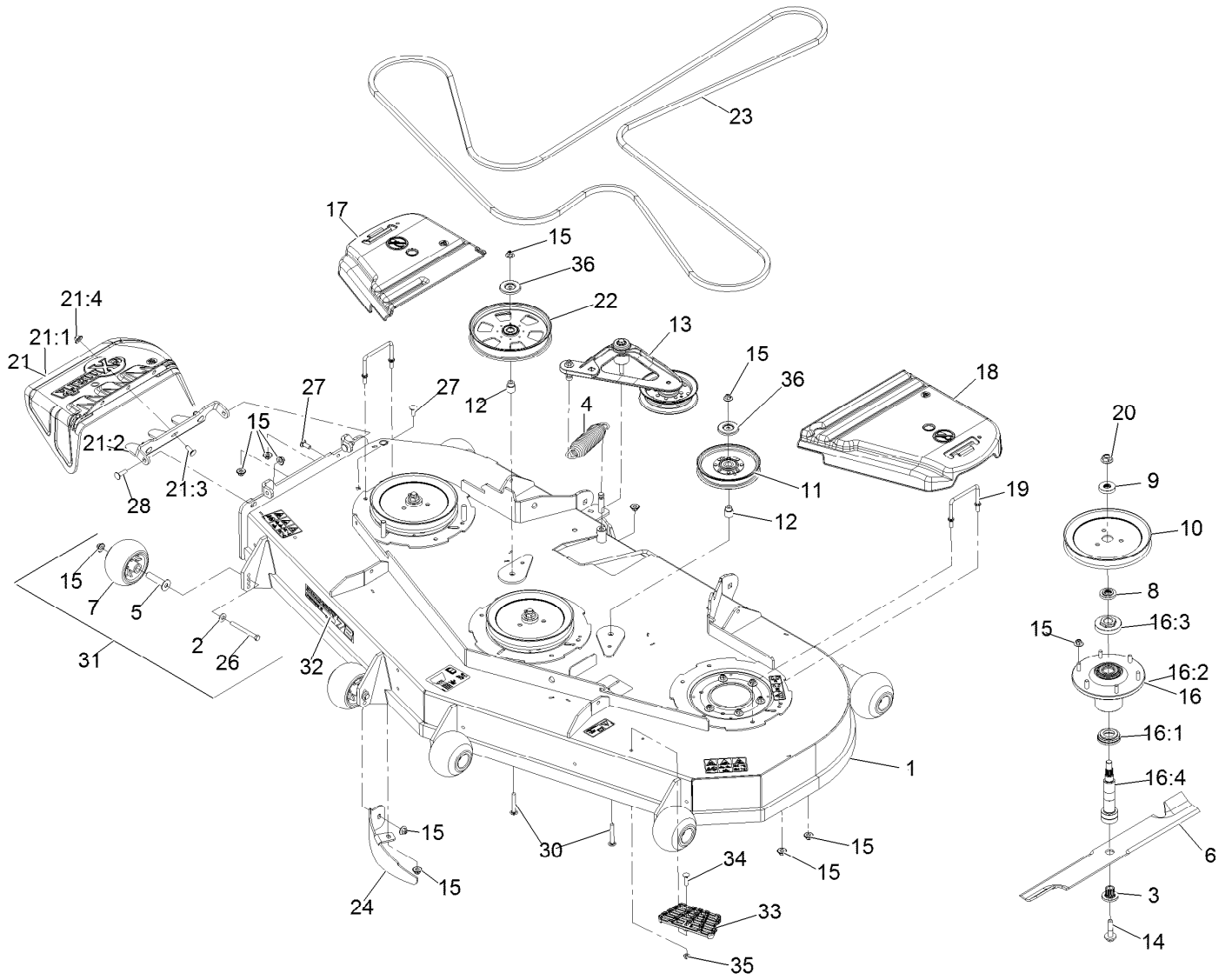

## Deck Assembly (continued)

| <i>Ref.</i> | <i>Part Number</i> | <i>Qty.</i> | <i>Description</i>       | <i>Ref.</i> | <i>Part Number</i> | <i>Qty.</i> | <i>Description</i>               |
|-------------|--------------------|-------------|--------------------------|-------------|--------------------|-------------|----------------------------------|
| 1           | 116-1665           | 1           | ASM,Deck W/Decals 724    | 18          | 109-6938           | 1           | Cover-Belt, LH                   |
| 2           | 98-5975            | 6           | Washer-Spring Disc 3/8   | 19          | 109-6982           | 2           | Wireform-Cover                   |
| 3           | 103-3037           | 3           | Bushing, Splined         | 20          | 109-7033           | 3           | Nut-Flange 5/8-18<br>Centerlock  |
| 4           | 116-6317           | 1           | Spring-Extension         | 21          | 109-7188           | 1           | ASM,Discharge Chute              |
| 5           | 116-8131           | 6           | Axle, Roller             | 21:1        | 109-2738           | 1           | Chute, Discharge                 |
| 6           | 103-6384           | 3           | Blade, Solid (72")       | 21:2        | 109-8675-01        | 1           | Bracket,Discharge Chute          |
| 6           | 103-6389           | 3           | Blade, Low Lift (72")    | 21:3        | 3231-22            | 3           | Bolt-Carriage 3/8-16 X 1         |
| 6           | 103-6394           | 3           | Blade, Mulching ■        | 21:4        | 109-6658           | 3           | Nut-Nyloc 3/8-16 Flg             |
| 6           | 103-6404           | 3           | Blade, Notched (72")     | 22          | 116-9639           | 1           | Pulley-Idler, Flat               |
| 6           | 116-5171           | 3           | Blade-Extreme 2, 24.50"  | 23          | 135-5777           | 1           | Belt-V                           |
| 7           | 103-8415           | 6           | Roller-Anti-Scalp        | 24          | 116-5834-01        | 1           | Baffle-Dogleg, Lz72              |
| 8           | 103-9522           | 3           | Spacer, Splined Stepped  | 26          | 116-9362           | 6           | Screw-HH 3/8-16 X 3 3/4<br>GR 8  |
| 9           | 103-9523           | 3           | Spacer, Splined          | 27          | 3231-22            | 2           | Bolt-Carriage 3/8-16 X 1         |
| 10          | 109-2180           | 3           | Sheave,Blade Drive 9.00  | 28          | 3231-28            | 2           | Bolt-Carriage 3/8-16 X 1 1/4     |
| 11          | 126-7685           | 1           | Idler-Pulley             | 30          | 3231-44            | 2           | Bolt-Carriage 3/8-16 X 2 1/2     |
| 12          | 1-633456           | 2           | Bushing, Idler           | 31          | 116-9981           | 6           | Kit, Anti-Scalp Roller           |
| 13          | 116-3755           | 1           | Deck Idler ASM           | 32          | 126-6593           | 1           | Decal, 726                       |
| 14          | 109-9220           | 3           | Screw-Sems 1/2-20 X 2.19 | 33          | 126-4781-03        | 1           | Step-Deck                        |
| 15          | 109-6658           | 34          | Nut-Nyloc 3/8-16 Flg     | 34          | 3230-3             | 1           | Bolt-Carriage 5/16-18 X 1<br>1/4 |
| 16          | 109-6917           | 3           | ASM,Spindle Housing      | 35          | 104-8300           | 1           | Nut-Nyloc 5/16-18 Flg            |
| 16:1        | 103-9504           | 1           | Guard, Bottom            | 36          | 126-8043           | 2           | Shield-Dust                      |
| 16:2        | 103-9539           | 1           | Asm, Cutter Housing      |             |                    |             |                                  |
| 16:3        | 109-0916           | 1           | Nut, Spindle 7/8-14 ●    |             |                    |             |                                  |
| 16:4        | 109-6881           | 1           | Spindle,Double Spline ▲  |             |                    |             |                                  |
| 17          | 116-0094           | 1           | Cover-Belt, RH           |             |                    |             |                                  |

● Torque to 160-185 ft-lb

■ Requires installation of mulch kit for proper mulching. See your Exmark dealer for details.

▲ Apply Mobil HTS grease (P/N 103-5217 1.5 oz packet) (or a food-grade anti-seize). See operator s manual for locations.

# Deck W/Decals Assembly No. 116-1665

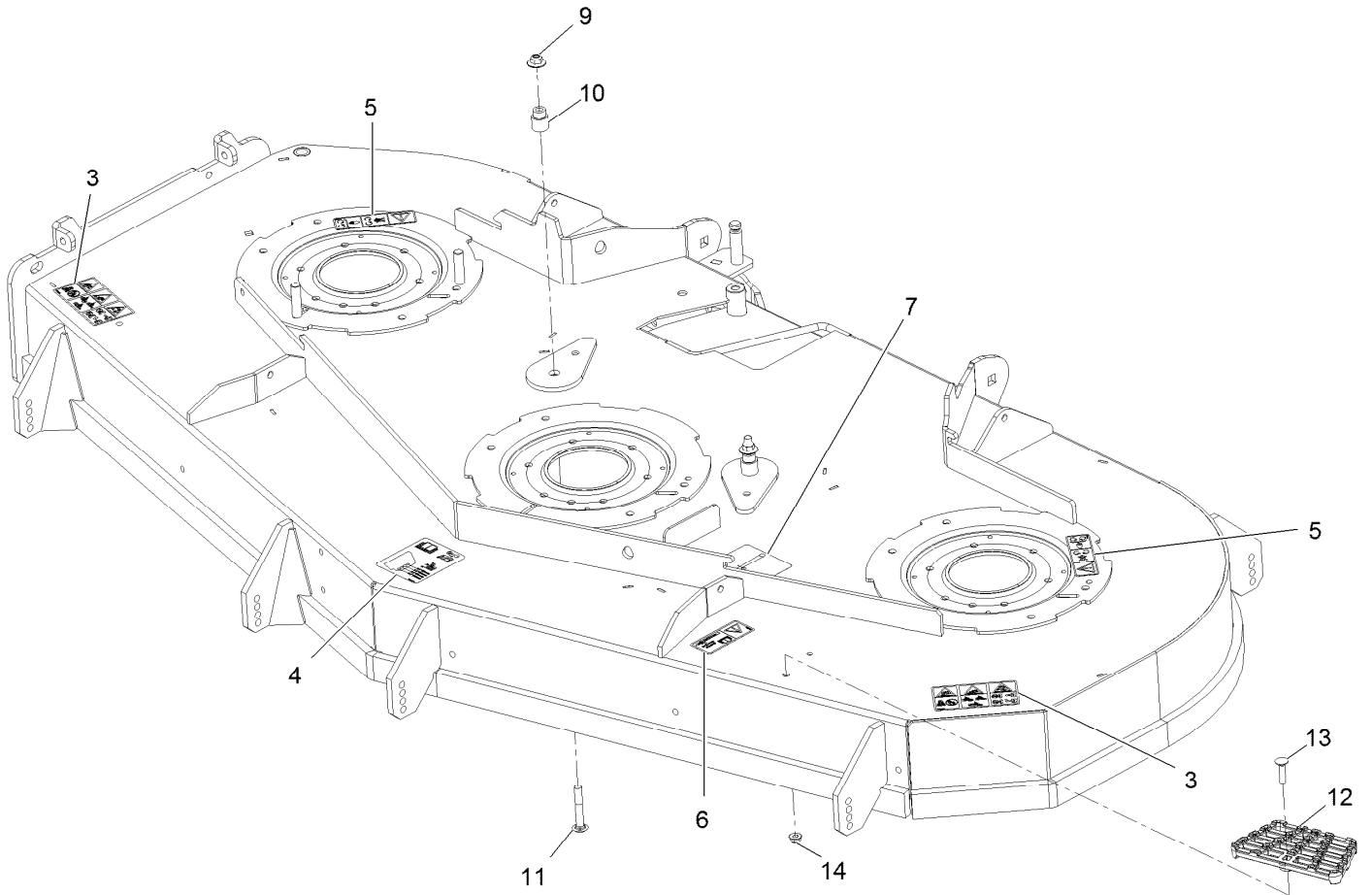



## Deck W/Decals Assembly No. 116-1665 (continued)

| <i>Ref.</i> | <i>Part Number</i> | <i>Qty.</i> | <i>Description</i>             | <i>Ref.</i> | <i>Part Number</i> | <i>Qty.</i> | <i>Description</i> |
|-------------|--------------------|-------------|--------------------------------|-------------|--------------------|-------------|--------------------|
| 3           | 126-6464           | 2           | Decal-Danger Thrown<br>Objects | 9           | 109-6658           | 2           | Nut-Flange, NI     |
| 4           | 109-6036           | 1           | Decal-Roller, Anti-Scalp       | 10          | 1-633456           | 2           | Bushing, Idler     |
| 5           | 112-9028           | 2           | Decal-Cover, Missing           | 11          | 3231-44            | 2           | Screw-CARR         |
| 6           | 116-8283           | 1           | Decal-Torque, Bolt             | 12          | 126-4781-03        | 1           | Step-Deck          |
| 7           | 116-8727           | 1           | Decal-Belt Routing             | 13          | 3230-3             | 1           | Screw-CARR         |
|             |                    |             |                                | 14          | 104-8300           | 1           | Nut-HF, NI         |

# Idler Assembly



## Idler Assembly (continued)

| <i>Ref.</i> | <i>Part Number</i> | <i>Qty.</i> | <i>Description</i> | <i>Ref.</i> | <i>Part Number</i> | <i>Qty.</i> | <i>Description</i> |
|-------------|--------------------|-------------|--------------------|-------------|--------------------|-------------|--------------------|
| 1           | 43-0940            | 1           | Spacer             | 9           | 126-0423           | 1           | Pin-Spring, Anchor |
| 2           | 103-2916           | 1           | Guard-Top          | 10          | 109-6658           | 2           | Nut-Flange, NI     |
| 3           | 103-3504           | 2           | Bearing-Spherical  | 11          | 109-7409           | 1           | Screw-Shoulder, HH |
| 4           | 103-3505           | 1           | Seal-Lip, Double   | 12          | 323-8              | 1           | Screw-HH           |
| 5           | 103-3506           | 1           | Seal-Lip, Single   | 13          | 32120-10           | 2           | Ring-Snap          |
| 6           | 126-9196           | 1           | Idler-Pulley, Flat | 14          | 302-19             | 1           | Fitting-Grease     |
| 7           | 106-7159           | 2           | O-Ring             | 15          | 126-9195           | 1           | Shield-Guard, Dust |

# Cutter Housing Assembly No. 103-9539



# Cutter Housing Assembly No. 103-9539 (continued)

| <i>Ref.</i> | <i>Part Number</i> | <i>Qty.</i> | <i>Description</i>      | <i>Ref.</i> | <i>Part Number</i> | <i>Qty.</i> | <i>Description</i>   |
|-------------|--------------------|-------------|-------------------------|-------------|--------------------|-------------|----------------------|
| 1           | 92-5581            | 1           | Ring-Rtng,Snap,Int,Flat | 4           | 103-9506           | 1           | Spacer, Bearing      |
| 2           | 109-2064           | 1           | Asm, Bearing W/O-Rings  | 5           | 109-0764           | 1           | Asm, Housing W/Studs |
| 3           | 103-5895           | 4           | O-Ring                  |             |                    |             |                      |

# Full Suspension Assembly

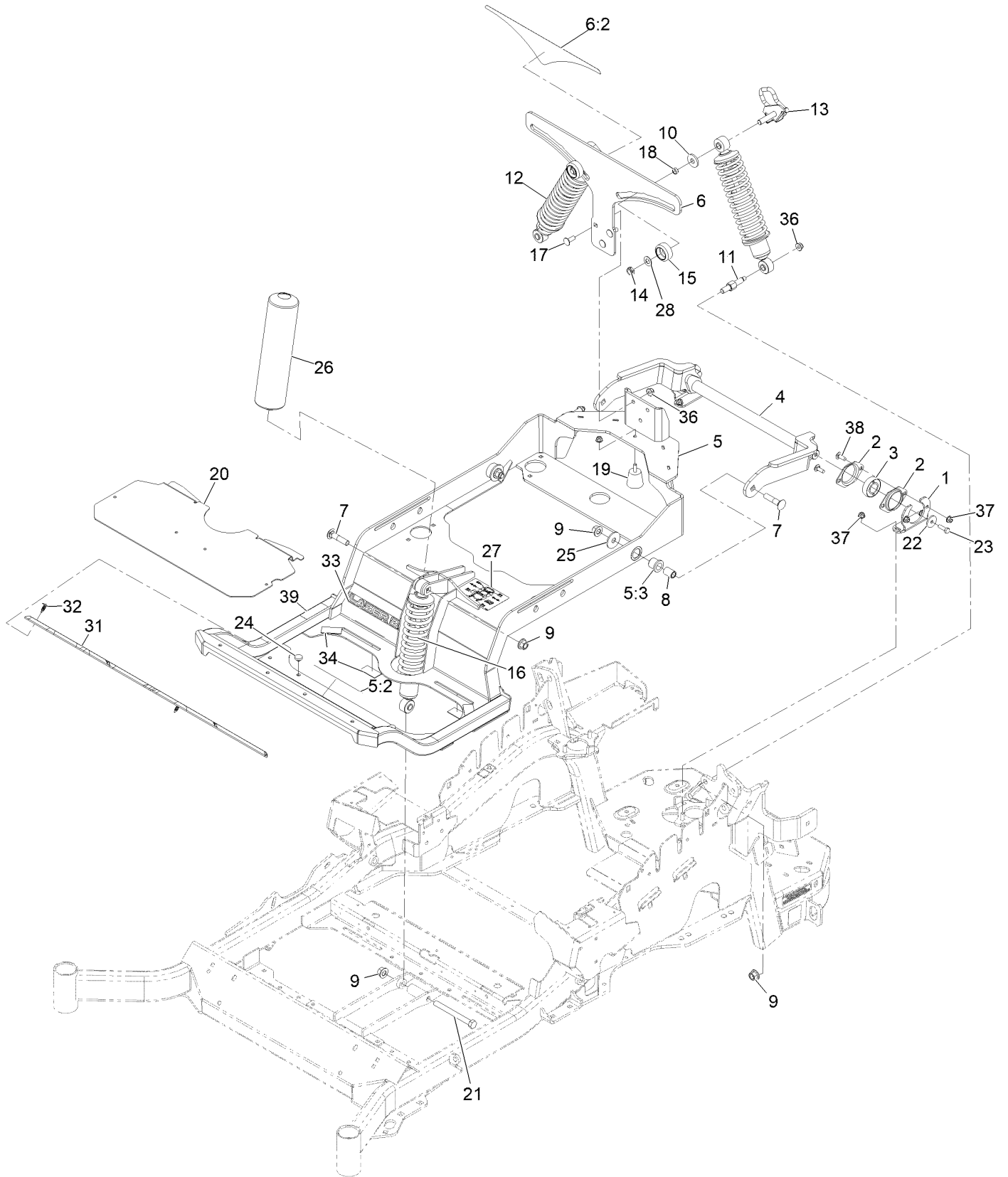

## Full Suspension Assembly (continued)

| <i>Ref.</i> | <i>Part Number</i> | <i>Qty.</i> | <i>Description</i>           | <i>Ref.</i> | <i>Part Number</i> | <i>Qty.</i> | <i>Description</i>              |
|-------------|--------------------|-------------|------------------------------|-------------|--------------------|-------------|---------------------------------|
| 1           | 127-6759-03        | 2           | Bracket-Bearing              | 18          | 133-5109           | 2           | Bearing-Sleeve                  |
| 2           | 127-6743           | 4           | Housing-Bearing, Flange      | 19          | 132-5058           | 1           | Bumper-Rubber                   |
| 3           | 1-653346           | 2           | Bearing                      | 20          | 144-0381-01        | 1           | Floorpan                        |
| 4           | 127-6754-03        | 1           | Arm-Trailing                 | 21          | 325-19             | 1           | Screw-HH 1/2-13 X 5             |
| 5           | 140-4868           | 1           | Subframe ASM                 | 22          | 105-3048           | 2           | Washer-Flat                     |
| 5:2         | 132-0871           | 1           | Decal-Danger                 | 23          | 116-0648           | 2           | Screw-HH 5/16-18 X 1<br>W/Patch |
| 5:3         | 127-6745           | 2           | Bushing-Flange               | 24          | 1-513658           | 2           | Bumper                          |
| 6           | 144-2601           | 1           | Bracket-Mounting             | 25          | 86-1990            | 2           | Washer                          |
| 6:2         | 132-5080           | 1           | Decal-Adjustment, Ride       | 26          | 133-1803           | 1           | Cover-Shock                     |
| 7           | 127-6768           | 3           | Bolt-Carriage 1/2-13 X 2 1/4 | 27          | 114-4465           | 1           | Decal-Service Aid               |
| 8           | 127-6751           | 2           | Spacer-Aluminum              | 28          | 3-6803             | 2           | Washer-Adjusting                |
| 9           | 99-5107            | 6           | Nut-Lock 1/2-13              | 31          | 144-0408           | 1           | Floor Mat                       |
| 10          | 131-4699           | 2           | Washer-Plastic               | 32          | 117-2382           | 2           | Plug-Plastic                    |
| 11          | 131-6348           | 2           | Bolt-Shoulder                | 33          | 133-1804           | 1           | Decal-Lazer Logo                |
| 12          | 133-1815           | 2           | Shock/Spring ASM             | 34          | 130-0733           | 4           | Pad-Rubber                      |
| 13          | 136-9017           | 2           | Cam Lock ASM                 | 36          | 104-8301           | 5           | Nut-Nyloc 3/8-16 Flg            |
| 14          | 3296-45            | 2           | Nut-Nyloc 1/2-13 Thin        | 37          | 104-8300           | 9           | Nut-Nyloc 5/16-18 Flg           |
| 15          | 136-5636           | 2           | Knob-Lock, Cam               | 38          | 3230-10            | 4           | Bolt-Carriage 5/16-18 X 7/8     |
| 16          | 136-1719           | 1           | Shock ASM-Front              | 39          | 115-9625           | 1           | Decal-Brake, Parking            |
| 16          | 136-8993           | 1           | Shock/Spring ASM             |             |                    |             |                                 |
| 17          | 3231-22            | 3           | Bolt-Carriage 3/8-16 X 1     |             |                    |             |                                 |

# Main Frame Assembly

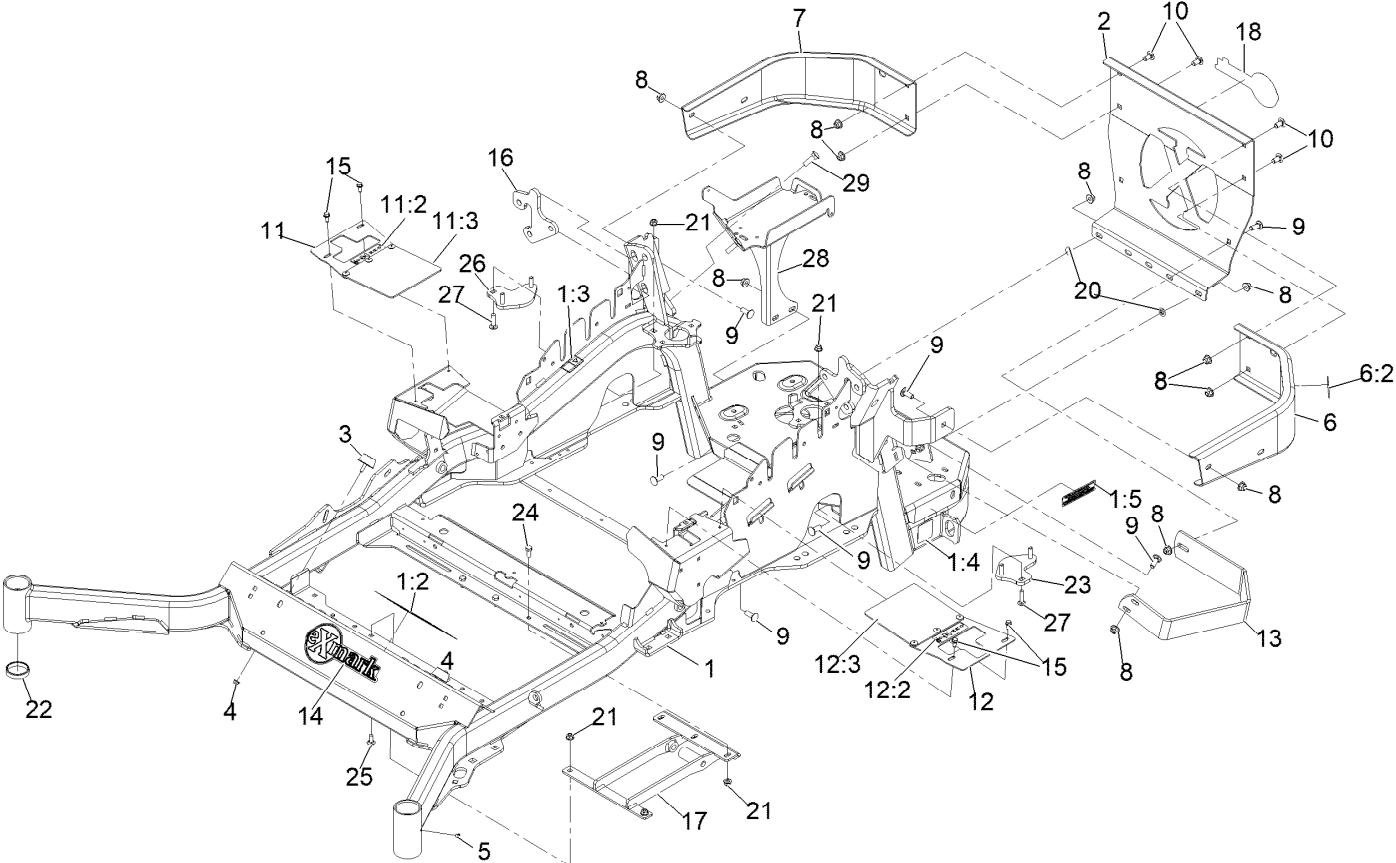



## Main Frame Assembly (continued)

| <i>Ref.</i> | <i>Part Number</i> | <i>Qty.</i> | <i>Description</i>           | <i>Ref.</i> | <i>Part Number</i> | <i>Qty.</i> | <i>Description</i>                     |
|-------------|--------------------|-------------|------------------------------|-------------|--------------------|-------------|--|
| 1           | 142-7266           | 1           | Mainframe Service ASM - 72   | 12:2        | 99-8936            | 1           | Decal-Control, Motion                  |
| 1:2         | 106-5517           | 2           | Decal-Warning                | 12:3        | 136-8967           | 1           | Flap-Rubber                            |
| 1:3         | 132-0871           | 1           | Decal-Danger                 | 13          | 126-2067-03        | 1           | Guard-Muffler                          |
| 1:4         | 106-2655           | 2           | Decal-Hazard, Pinched Finger | 14          | 135-2274           | 1           | Decal-Exmark                           |
| 1:5         | 133-8062           | 1           | Decal-Arrestor, Spark        | 15          | 32144-10           | 4           | Screw-HWH 1/4-20 X .62                 |
| 2           | 109-8863-03        | 1           | Plate,Rear Guard             | 16          | 136-1674-01        | 2           | Plate-Mount, Shock                     |
| 3           | 131-8834           | 2           | Bumper                       | 17          | 131-6327-01        | 1           | Mount-Lower                            |
| 4           | 104-7201           | 2           | Nut-Nyloc 1/4-20 Flg         | 18          | 126-6877           | 1           | Decal, Exmark Logo                     |
| 5           | 1-811010           | 2           | Plug                         | 20          | 107-3154           | 2           | Nut-Push 3/8-16                        |
| 6           | 116-0180           | 1           | LH Bumper ASM                | 21          | 104-8300           | 7           | Nut-Nyloc 5/16-18 Flg                  |
| 6:2         | 106-5517           | 1           | Decal-Warning                | 22          | 1-543508           | 4           | Cup-Bearing Tapered Roller             |
| 7           | 116-0057-03        | 1           | Bumper-RH                    | 23          | 127-6766           | 1           | LH Plate ASM (W/Studs)                 |
| 8           | 104-8301           | 15          | Nut-Nyloc 3/8-16 Flg         | 24          | 322-3              | 3           | Screw-HH 5/16-18 X 3/4                 |
| 9           | 3231-22            | 9           | Bolt-Carriage 3/8-16 X 1     | 25          | 3230-23            | 2           | Bolt-Carriage 5/16-18 X 3/4 Short Neck |
| 10          | 3231-21            | 4           | Bolt-Carriage 3/8-16 X 3/4   | 26          | 127-6765           | 1           | RH Plate ASM (W/Studs)                 |
| 11          | 131-4615           | 1           | RH Motion Control Cover ASM  | 27          | 3230-3             | 2           | Bolt-Carriage 5/16-18 X 1 1/4          |
| 11:2        | 99-8936            | 1           | Decal-Control, Motion        | 28          | 142-6404-01        | 1           | Battery Mount ASM [red]                |
| 11:3        | 136-8967           | 1           | Flap-Rubber                  | 29          | 3231-25            | 2           | Bolt-Carriage 3/8-16 X 1 1/4           |
| 12          | 131-4610           | 1           | LH Motion Control Cover ASM  |             |                    |             |  |

# X-Series Decal

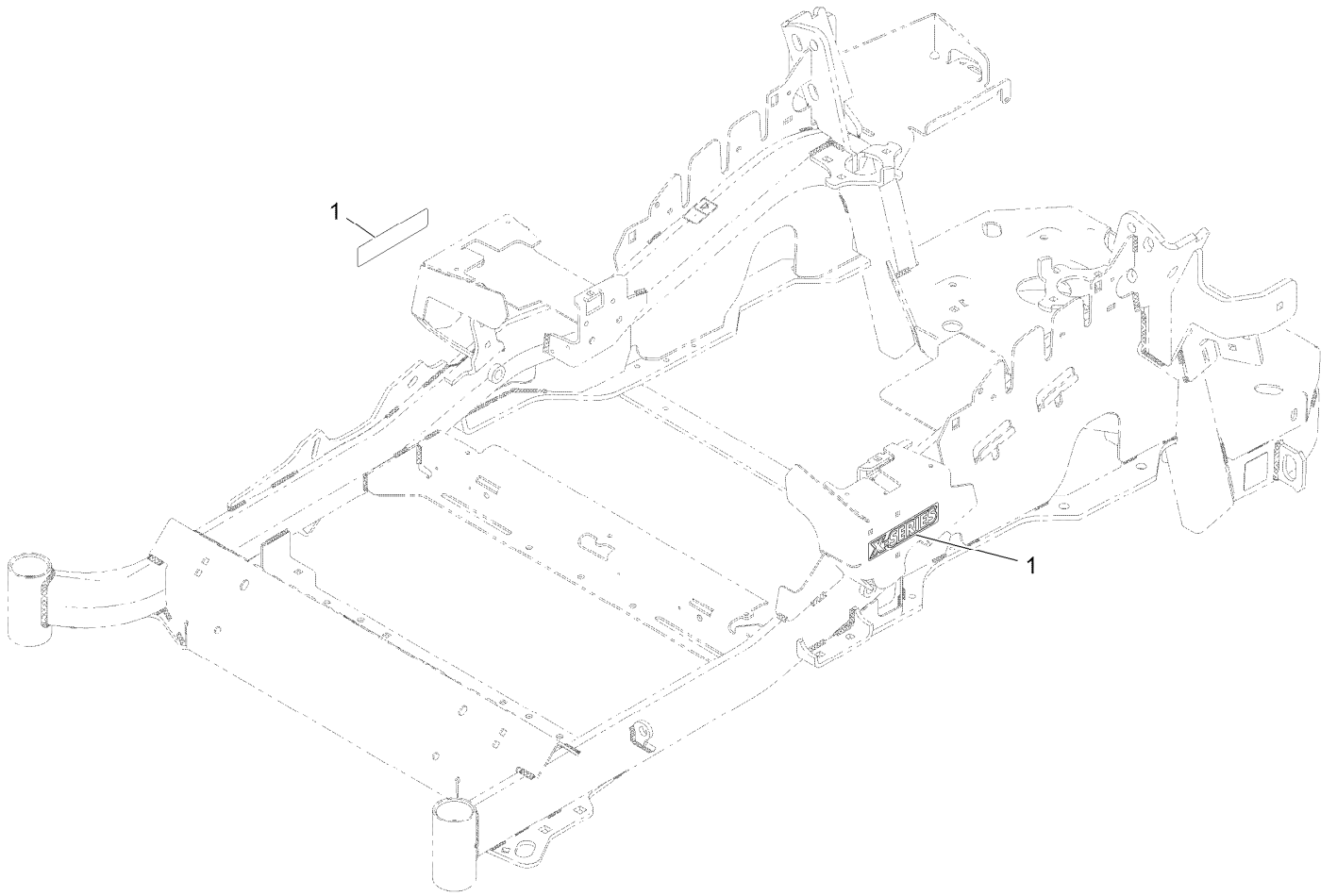

## X-Series Decal (continued)

| <i>Ref.</i> | <i>Part Number</i> | <i>Qty.</i> | <i>Description</i> |
|-------------|--------------------|-------------|--------------------|
| 1           | 126-6573           | 2           | Decal-X-Series     |

# Roll-Over Protection System

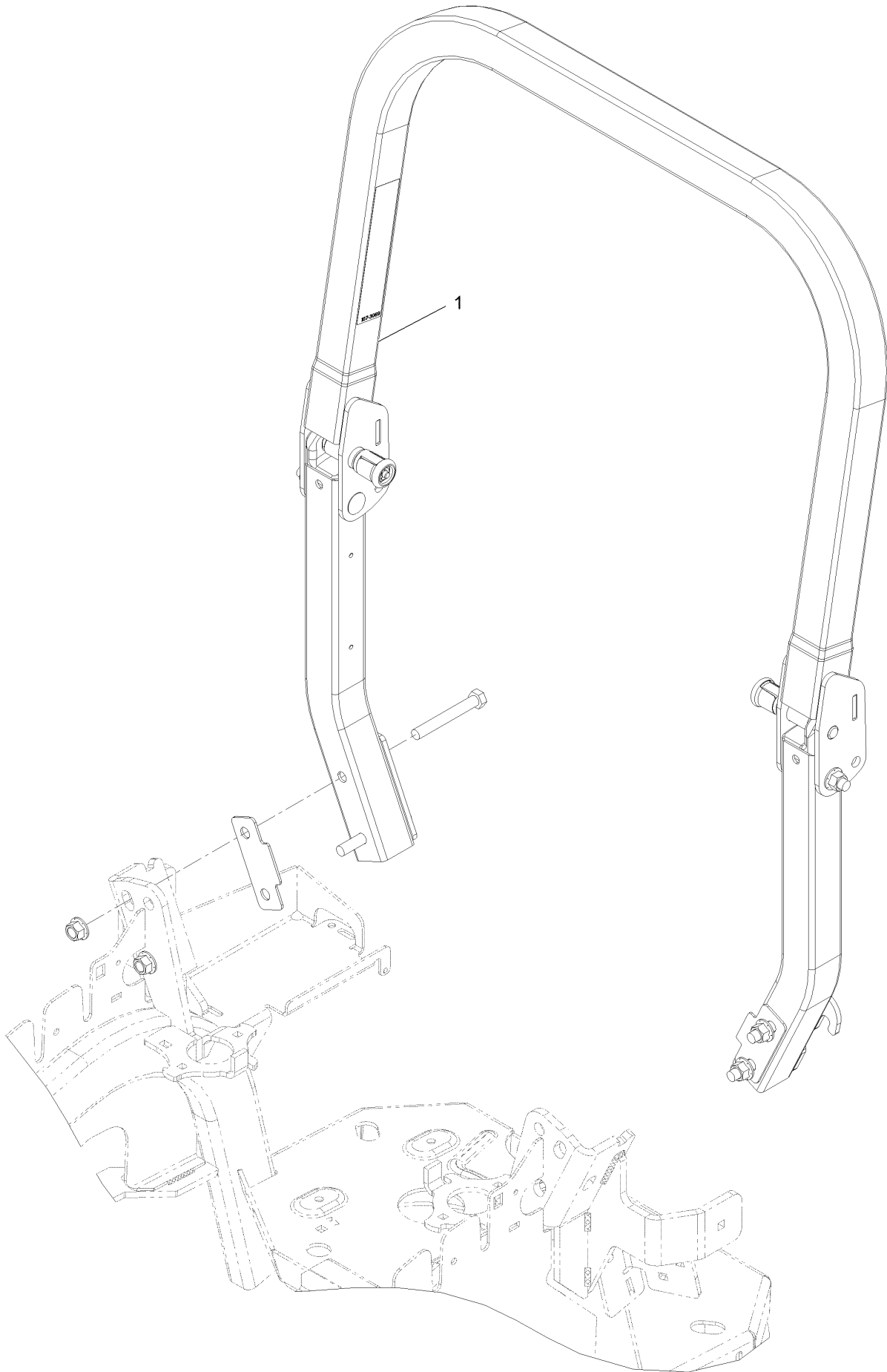

# Roll-Over Protection System (continued)

| <i>Ref.</i> | <i>Part Number</i> | <i>Qty.</i> | <i>Description</i>      |
|-------------|--------------------|-------------|-------------------------|
| 1           | 116-0230           | 1           | ASM,ROPS Service Exmark |

# Roll Over Protection System (cont.)

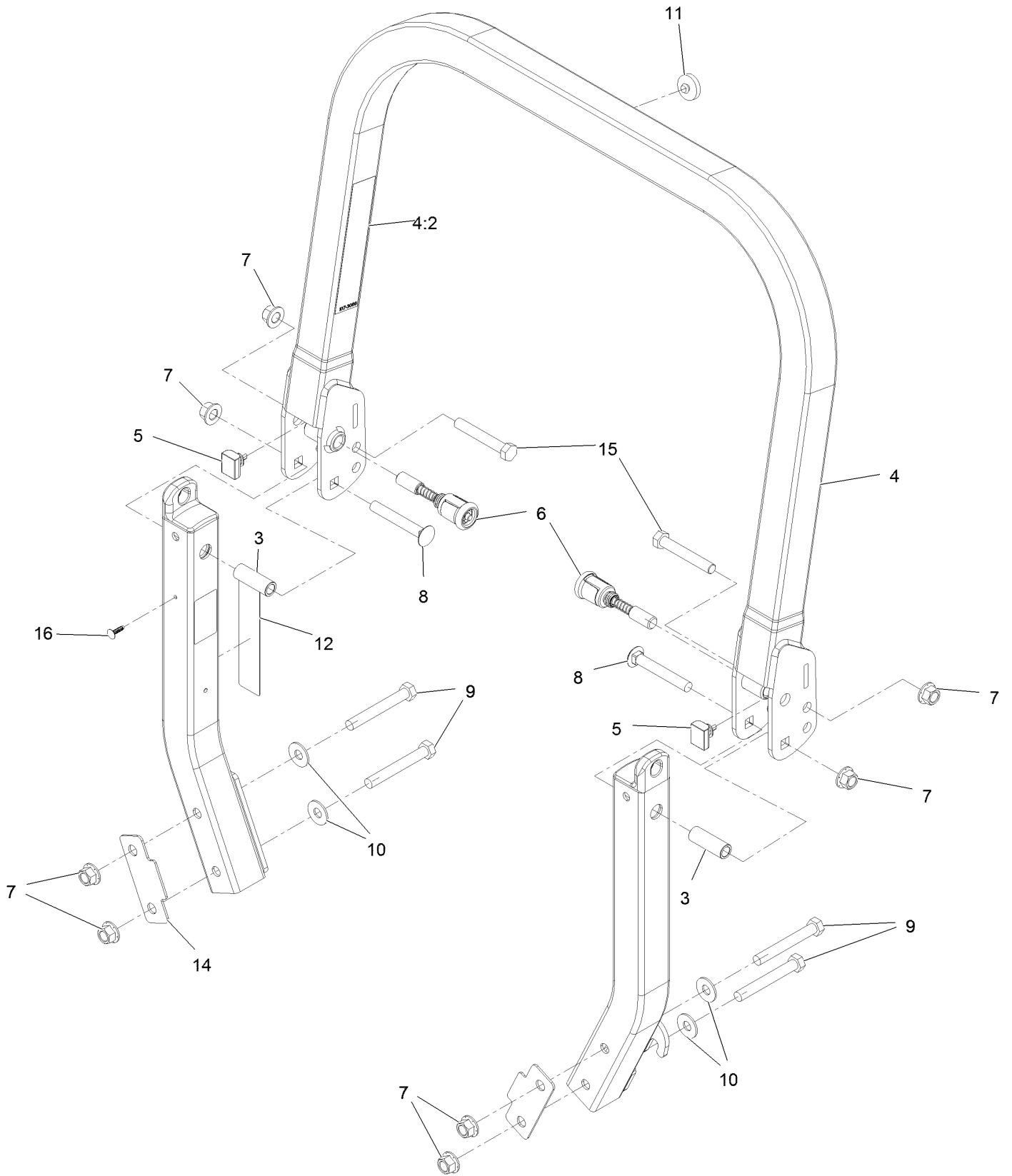

## Roll Over Protection System (cont.) (continued)

| <i>Ref.</i> | <i>Part Number</i> | <i>Qty.</i> | <i>Description</i>           | <i>Ref.</i> | <i>Part Number</i> | <i>Qty.</i> | <i>Description</i>       |
|-------------|--------------------|-------------|------------------------------|-------------|--------------------|-------------|--------------------------|
| 3           | 109-6653           | 2           | Spacer                       | 9           | 325-35             | 4           | Screw-HH                 |
| 4           | 116-0019           | 1           | Upper ROPS ASM               | 10          | 109-9505           | 4           | Washer, Spring Disc 1/2  |
| 4:2         | 107-3069           | 1           | Decal-Warning                | 11          | 109-9233           | 1           | Bumper-Push-In, Rubber   |
| 5           | 109-5337           | 2           | Bumper-ROPS                  | 12          | 117-0346           | 1           | Decal-Caution, Fuel Vent |
| 6           | 116-0104           | 2           | Pin-Spring                   | 14          | 116-0960           | 2           | Spacer                   |
| 7           | 99-5107            | 8           | Nut-Lock 1/2-13              | 15          | 325-13             | 2           | Screw-HH                 |
| 8           | 3233-10            | 2           | Bolt-Carriage 1/2-13 X 3 1/2 | 16          | 125-8067           | 1           | Plug-Plastic             |

# Front Caster and Fork Assembly

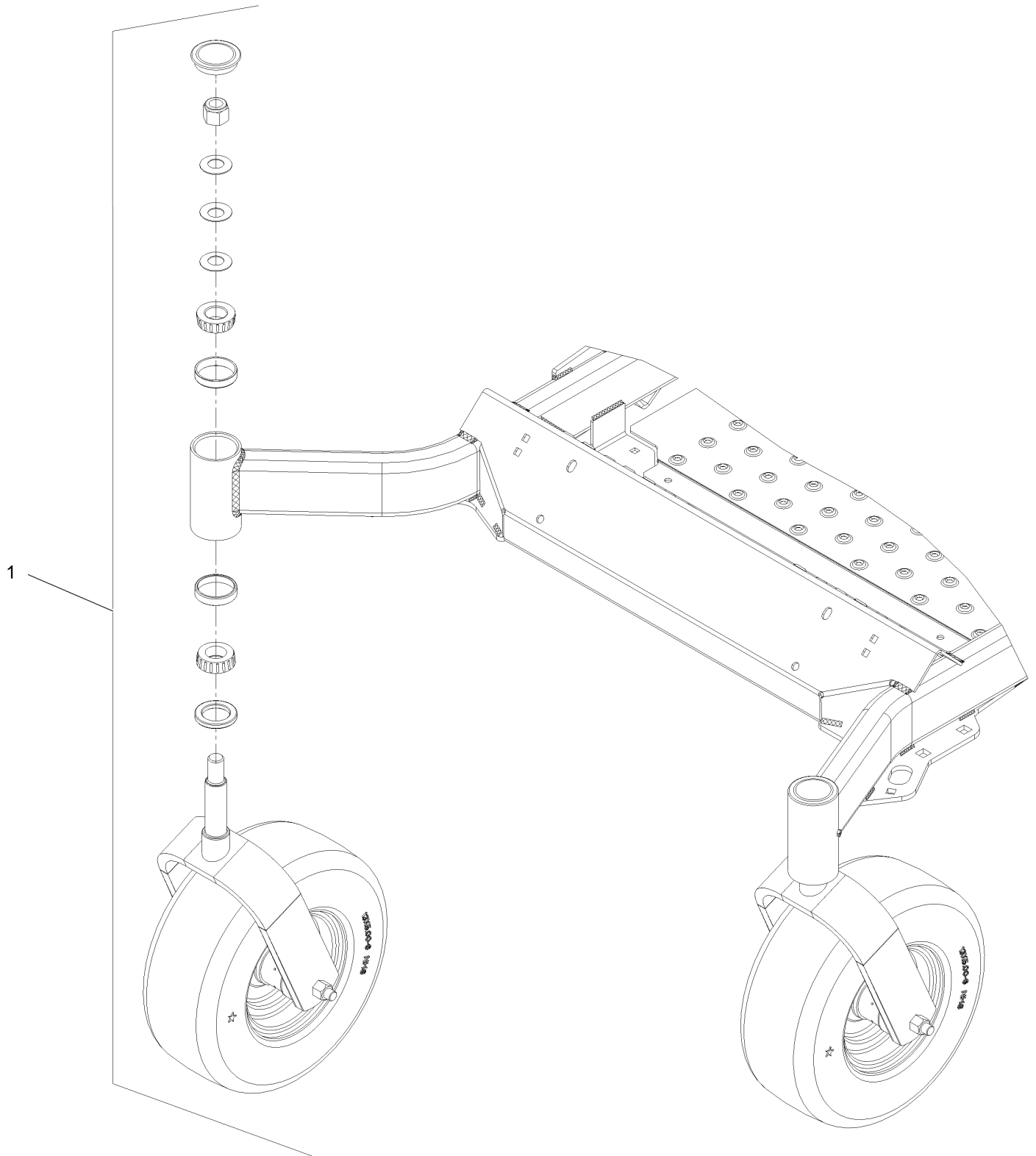



# Front Caster and Fork Assembly (continued)

| <i>Ref.</i> | <i>Part Number</i> | <i>Qty.</i> | <i>Description</i>        |
|-------------|--------------------|-------------|---------------------------|
| 1           |                    | 2           | Front Caster And Fork ASM |
|             |                    |             | ●                         |

● Not serviced separately

# Caster Wheel and Fork Assembly

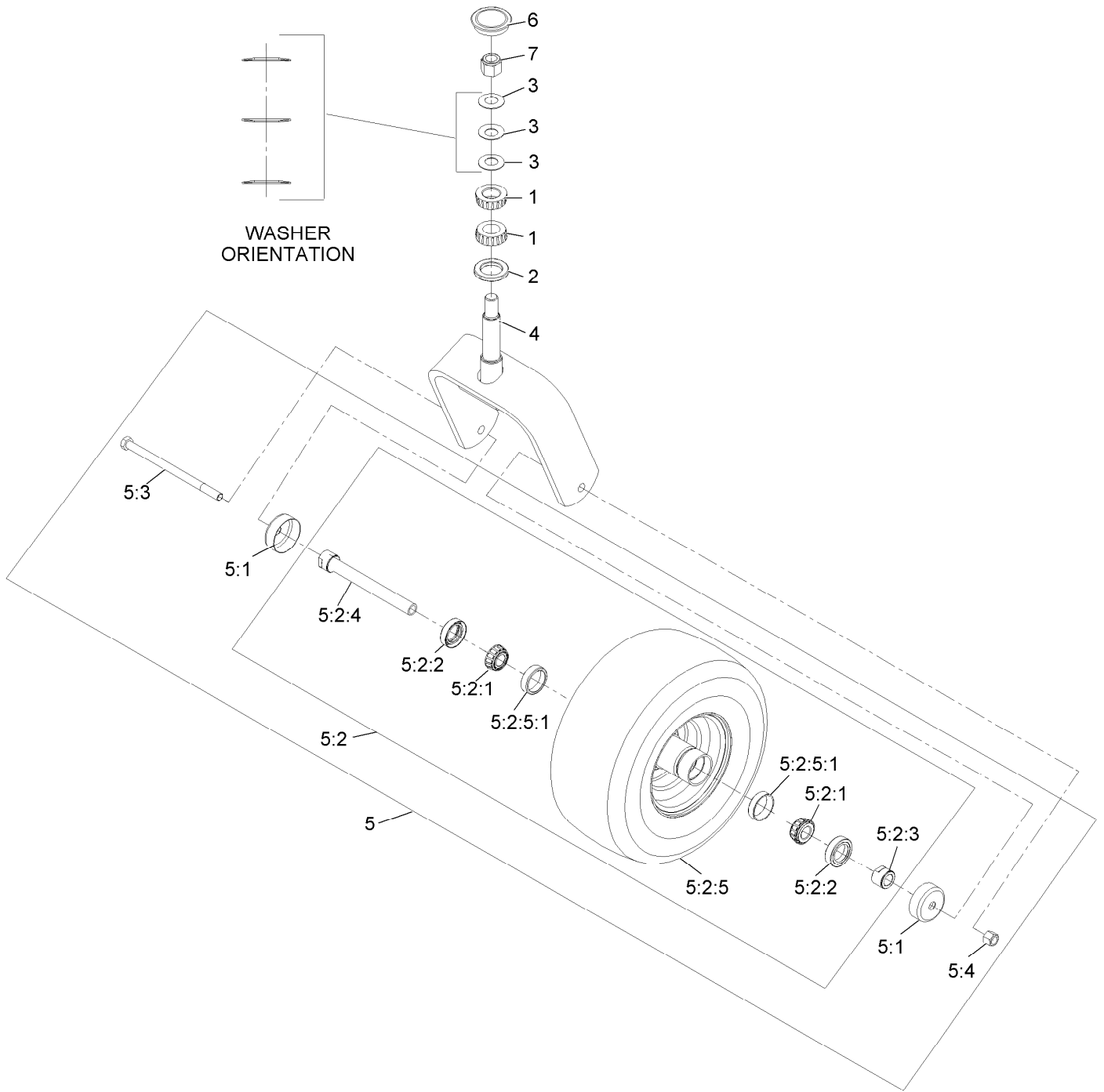

## Caster Wheel and Fork Assembly (continued)

| <i>Ref.</i> | <i>Part Number</i> | <i>Qty.</i> | <i>Description</i>      | <i>Ref.</i> | <i>Part Number</i> | <i>Qty.</i> | <i>Description</i>   |
|-------------|--------------------|-------------|-------------------------|-------------|--------------------|-------------|----------------------|
| 1           | 1-543509           | 2           | Bearing-Roller, Tapered | 5:2:3       | 103-3051           | 1           | Spacer-Nut ■         |
| 2           | 116-5647           | 1           | Seal-Grease             | 5:2:4       | 126-5361           | 1           | Axle Caster ASM      |
| 3           | 1-633508           | 3           | Washer-Bellville        | 5:2:5       |                    | 1           | Wheel And Tire ASM ● |
| 4           | 116-6707-01        | 1           | Caster                  | 5:2:5:1     | 1-633584           | 2           | Bearing-Cup          |
| 5           | 109-9127           | 1           | Wheel & Tire ASM        | 5:3         | 325-39             | 1           | Screw-HH             |
| 5:1         | 103-2768           | 2           | Guard-Seal              | 5:4         | 3296-23            | 1           | Nut-Lock, NI         |
| 5:2         |                    | 1           | Wheel And Tire ASM ●    | 6           | 103-4882           | 1           | Cap-Grease           |
| 5:2:1       | 1-633585           | 2           | Bearing-Cone, Taper     | 7           | 3296-51            | 1           | Nut-Lock, NI         |
| 5:2:2       | 103-0063           | 2           | Seal-Caster             |             |                    |             |                      |

● Not serviced separately

■ Use Pro-Lock, Nut Type (P/N 1-840022, .5ml tube) on threads.

# Deck Lift Assembly

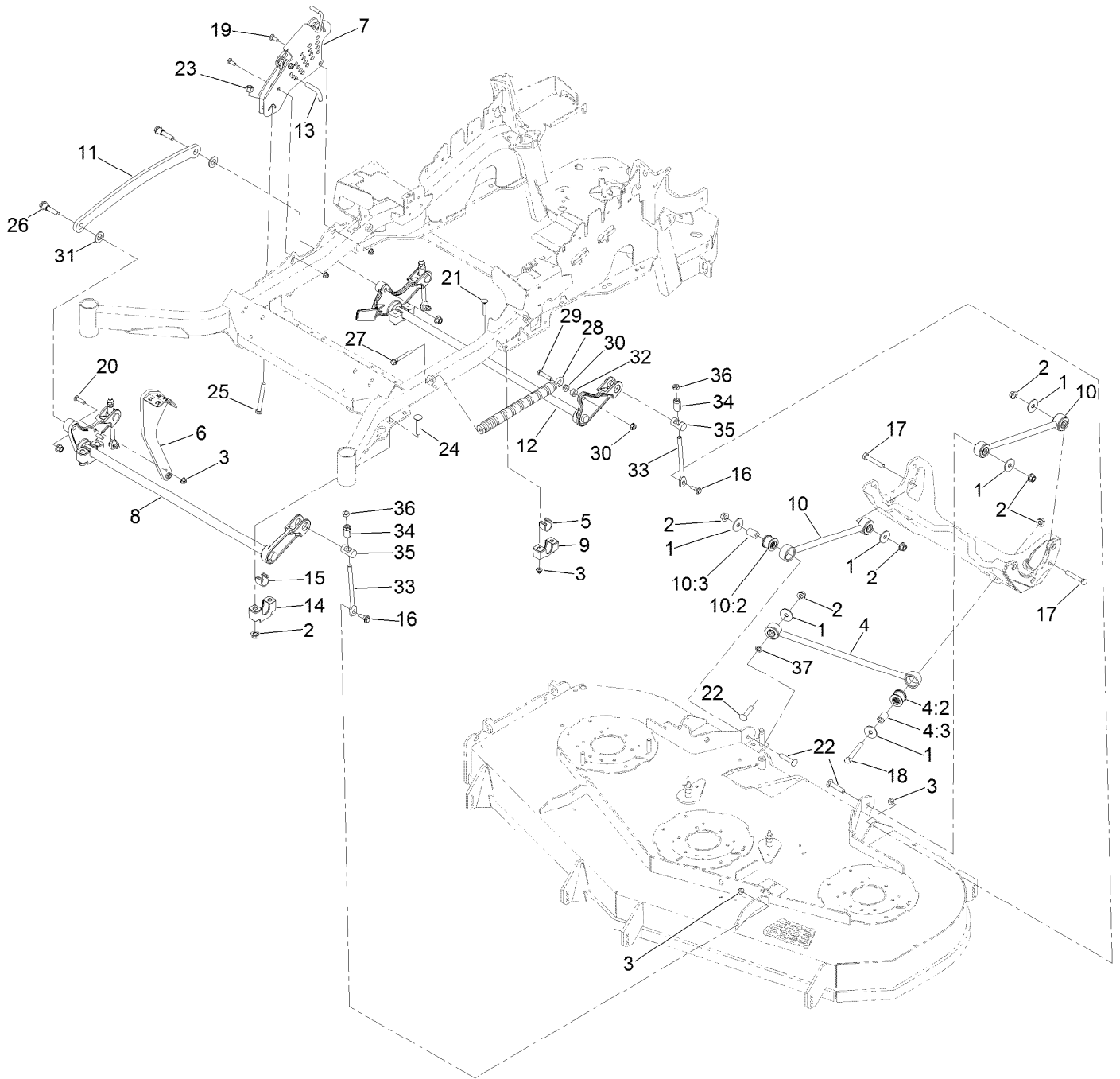

## Deck Lift Assembly (continued)

| <i>Ref.</i> | <i>Part Number</i> | <i>Qty.</i> | <i>Description</i>                      | <i>Ref.</i> | <i>Part Number</i> | <i>Qty.</i> | <i>Description</i>       |
|-------------|--------------------|-------------|---|-------------|--------------------|-------------|--------------------------|
| 1           | 86-1990            | 6           | Washer-Thrust                           | 16          | 109-9840           | 4           | Screw-Shoulder, HHF      |
| 2           | 99-5107            | 12          | Nut-Lock                                | 17          | 325-12             | 2           | Screw-HH                 |
| 3           | 104-8301           | 12          | Nut-HF, NI                              | 18          | 325-17             | 1           | Screw-HH                 |
| 4           | 109-5013           | 1           | Panhard Rod ASM                         | 19          | 3231-2             | 2           | Bolt-CARR                |
| 4:2         | 109-5009           | 2           | Bushing-Suspension,<br>Rubber           | 20          | 3231-4             | 2           | Screw-CARR               |
| 4:3         | 109-5010           | 2           | Spacer                                  | 21          | 3231-7             | 4           | Screw-CARR               |
| 5           | 109-7173           | 2           | Bearing-Cross Shaft, Rear               | 22          | 3233-34            | 3           | Screw-CARR               |
| 6           | 131-8812-01        | 1           | Lever-Foot                              | 23          | 3296-23            | 1           | Nut-Lock, NI             |
| 7           | 109-7438           | 1           | HOC ASM                                 | 24          | 116-1700           | 4           | Bolt-CARR                |
| 8           | 126-2477-03        | 1           | Decklift-Front                          | 25          | 116-0559           | 1           | Bolt-TAP                 |
| 9           | 127-0553           | 2           | Support-Bearing, Cross<br>Shaft (Rear)  | 26          | 116-2022           | 2           | Screw-HHF, Shoulder      |
| 10          | 109-7952           | 2           | Deck Strut ASM                          | 27          | 92-7674            | 1           | Bolt-Shoulder            |
| 10:2        | 109-5009           | 2           | Bushing-Suspension,<br>Rubber           | 28          | 116-0000           | 1           | Spring-Extension         |
| 10:3        | 109-5010           | 2           | Spacer                                  | 29          | 109-9065           | 1           | Screw-HH                 |
| 11          | 116-0797-03        | 1           | Link-Lift, Deck                         | 30          | 32128-37           | 2           | Nut-HF                   |
| 12          | 116-2645-03        | 1           | Lift-Deck, Rear                         | 31          | 3256-28            | 2           | Washer-Flat              |
| 13          | 116-5584           | 1           | Pin-HOC                                 | 32          | 116-2695           | 1           | Spacer                   |
| 14          | 109-9409           | 2           | Support-Bearing, Cross<br>Shaft (Front) | 33          | 109-8007           | 4           | Link-Adjuster, Deck Lift |
| 15          | 109-9410           | 2           | Bearing-Cross Shaft, Front              | 34          | 109-7840           | 4           | Adjuster-Lift, Deck      |
|             |                    |             |   | 35          | 109-8353           | 4           | Trunnion                 |
|             |                    |             |   | 36          | 3218-5             | 4           | Nut-Jam                  |
|             |                    |             |   | 37          | 126-2916           | 1           | Nut-Push                 |

# Height-of-Cut Assembly No. 109-7438

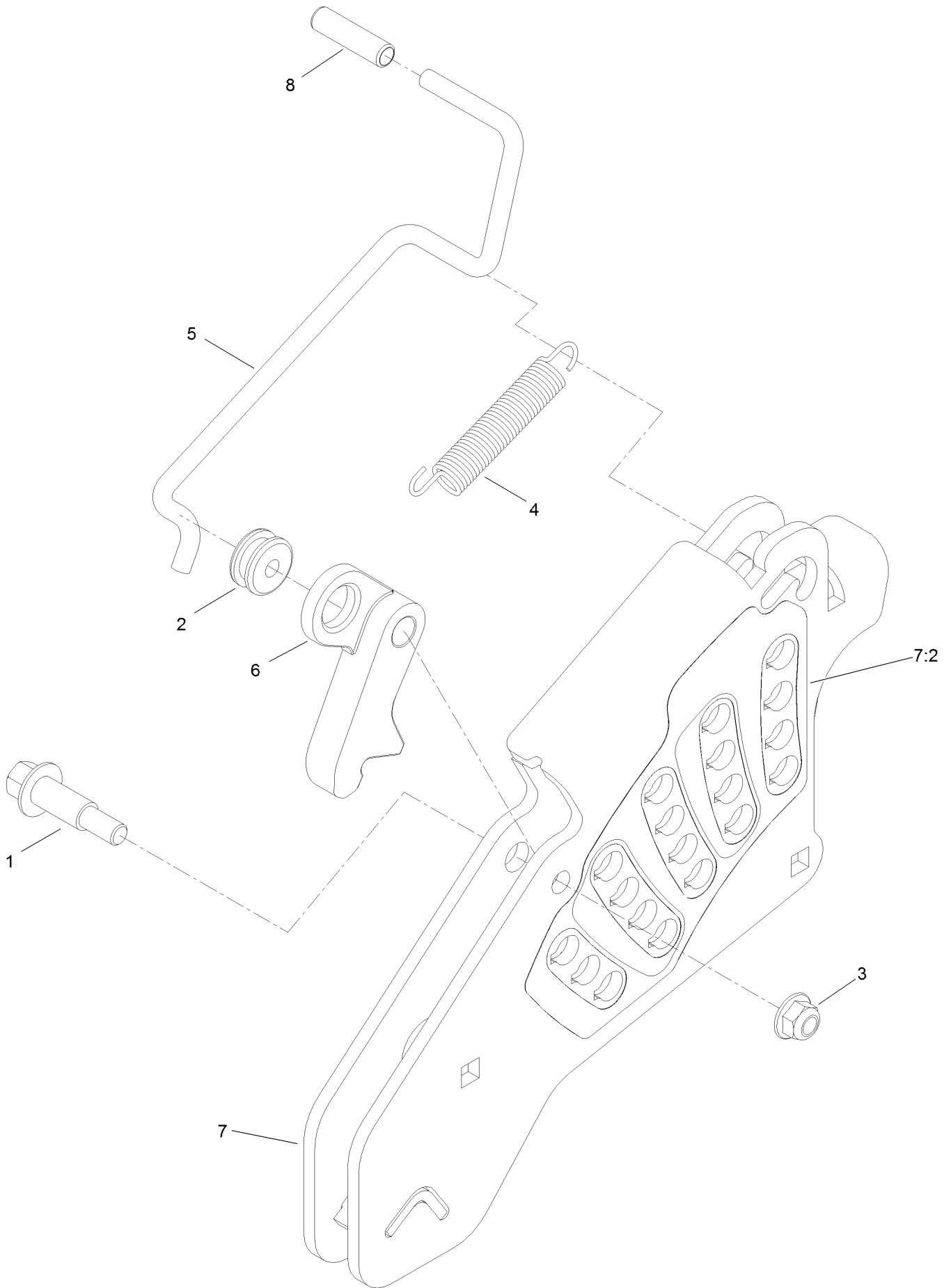

## Height-of-Cut Assembly No. 109-7438 (continued)

| <i>Ref.</i> | <i>Part Number</i> | <i>Qty.</i> | <i>Description</i>  | <i>Ref.</i> | <i>Part Number</i> | <i>Qty.</i> | <i>Description</i>  |
|-------------|--------------------|-------------|---------------------|-------------|--------------------|-------------|---------------------|
| 1           | 62-1330            | 1           | Bolt-Shoulder       | 6           | 116-0118           | 1           | Pawl-Transport, HOC |
| 2           | 109-7130           | 1           | Grommet             | 7           | 109-7335           | 1           | HOC Plate ASM       |
| 3           | 104-8301           | 1           | Nut-HF, NI          | 7:2         | 126-4398           | 1           | Decal-HOC           |
| 4           | 109-7124           | 1           | Spring-Extension    | 8           | 109-8250           | 1           | Grip-Lever          |
| 5           | 109-7128           | 1           | Rod-Lock, Transport |             |                    |             |                     |

# Controls Assembly

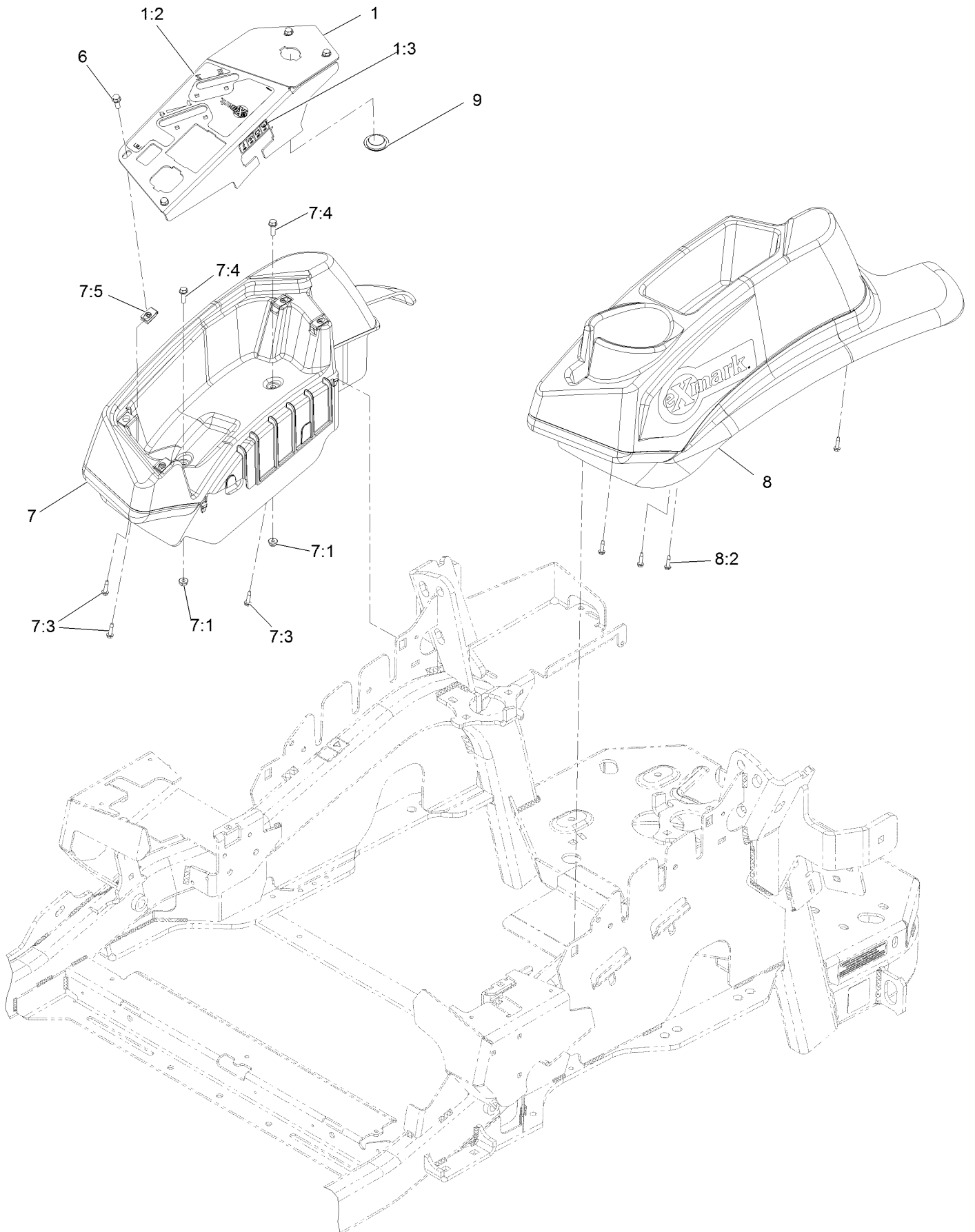



## Controls Assembly (continued)

| <i>Ref.</i> | <i>Part Number</i> | <i>Qty.</i> | <i>Description</i>             | <i>Ref.</i> | <i>Part Number</i> | <i>Qty.</i> | <i>Description</i>         |
|-------------|--------------------|-------------|--------------------------------|-------------|--------------------|-------------|----------------------------|
| 1           | 135-3146           | 1           | ASM-Panel, Control<br>W/Decal  | 7:1         | 104-7201           | 2           | Nut-Nyloc 1/4-20 Flg       |
| 1:2         | 116-8724           | 1           | Decal-Control Panel<br>Non-EFI | 7:3         | 109-9345           | 3           | Screw-HWH #10-14 X 3/4 Tf  |
| 1:3         | 114-4466           | 1           | Decal-Fuses                    | 7:4         | 32105-15           | 2           | Screw-Machine 1/4-20 X 3/4 |
| 6           | 32105-15           | 4           | Screw-Machine 1/4-20 X 3/4     | 7:5         | 107069             | 4           | Nut-Retainer-Panel 1/4-20  |
| 7           | 109-9341           | 1           | Console,RH Narrow ASM          | 8           | 109-9342           | 1           | Console.LH Narrow ASM      |
|             |                    |             |                                | 8:2         | 109-9345           | 4           | Screw-HWH #10-14 X 3/4 Tf  |
|             |                    |             |                                | 9           | 116-1875           | 1           | Plug-Plastic               |

# Motion Controls Assembly

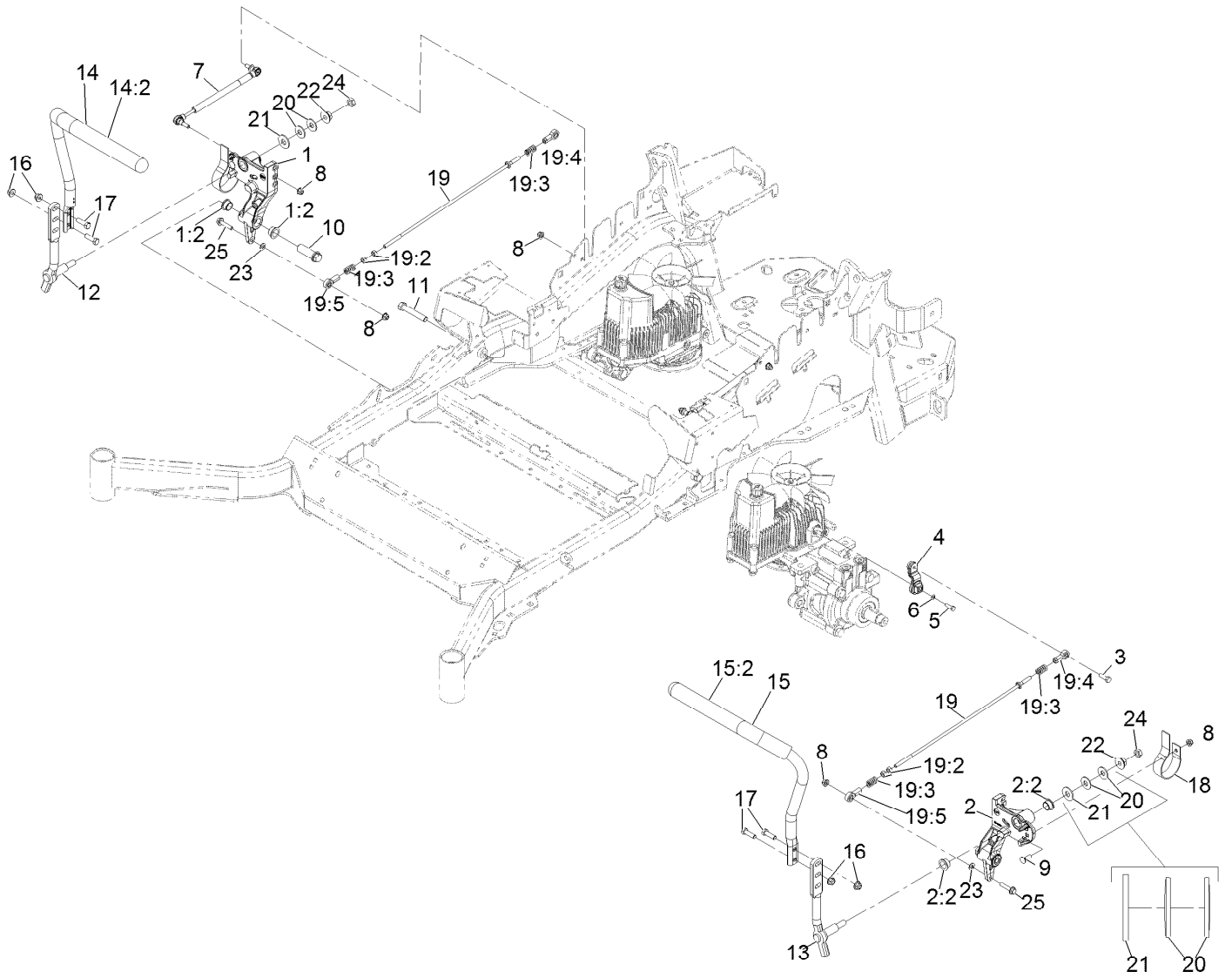

## Motion Controls Assembly (continued)

| <i>Ref.</i> | <i>Part Number</i> | <i>Qty.</i> | <i>Description</i>                | <i>Ref.</i> | <i>Part Number</i> | <i>Qty.</i> | <i>Description</i>               |
|-------------|--------------------|-------------|-----------------------------------|-------------|--------------------|-------------|----------------------------------|
| 1           | 116-0880           | 1           | RH Motion Control And Bushing ASM | 14:2        | 109-5668           | 1           | Grip-Lever, Control              |
| 1:2         | 109-8054           | 4           | Bushing-Flanged                   | 15          | 135-4476           | 1           | ASM-Handle-LH                    |
| 2           | 116-0881           | 1           | LH Motion Control And Bushing ASM | 15:2        | 109-5668           | 1           | Grip-Lever, Control              |
| 2:2         | 109-8054           | 4           | Bushing-Flanged                   | 16          | 104-8301           | 4           | Nut-Nyloc 3/8-16 Flg             |
| 3           | 116-0648           | 2           | Screw-HH 5/16-18 X 1 W/Patch ●    | 17          | 323-7              | 4           | Screw-HH 3/8-16 X 1 1/4          |
| 4           | 109-4581           | 2           | Arm-Control, Pump                 | 18          | 109-5575           | 2           | Spring-Leaf                      |
| 5           | 9080046            | 2           | Screw-HH 1/4-20 X 7/8 ●           | 19          | 109-8106           | 2           | Front Pump Linkage ASM           |
| 6           | 1-303435           | 2           | Washer-Spring Disc 1/4            | 19:2        | 3219-2             | 2           | Nut-Hex 5/16-24                  |
| 7           | 116-0027           | 2           | Damper-Control, Motion            | 19:3        | 1-323245           | 2           | Spring-Compression               |
| 8           | 104-8300           | 8           | Nut-Nyloc 5/16-18 Flg             | 19:4        | 1-633152           | 1           | Balljoint                        |
| 9           | 3230-2             | 2           | Bolt-Carriage 5/16-18 X 1         | 19:5        | 1-543017           | 1           | Balljoint                        |
| 10          | 109-5891           | 2           | Hub-Threaded                      | 20          | 109-9505           | 4           | Washer, Spring Disc 1/2          |
| 11          | 325-12             | 2           | Screw-HH 1/2-13 X 3               | 21          | 3256-6             | 2           | Washer                           |
| 12          | 116-0039           | 1           | Lever-Control Motion, RH          | 22          | 32128-56           | 2           | Nut-Hex 1/2-13 Flange            |
| 13          | 116-0040           | 1           | Lever-Control Motion, LH          | 23          | 3256-23            | 2           | Washer-5/16 SAE                  |
| 14          | 135-4727           | 1           | Handle- RH W/Grip                 | 24          | 3218-5             | 2           | Nut-Jam 1/2-13                   |
|             |                    |             |                                   | 25          | 115-1794           | 2           | Screw-Hex Flange 5/16-18 X 1 1/2 |

● Use Pro-Lock, Nut Type (P/N 1-840022, .5ml tube) on threads.

# Rear Wheel Assembly

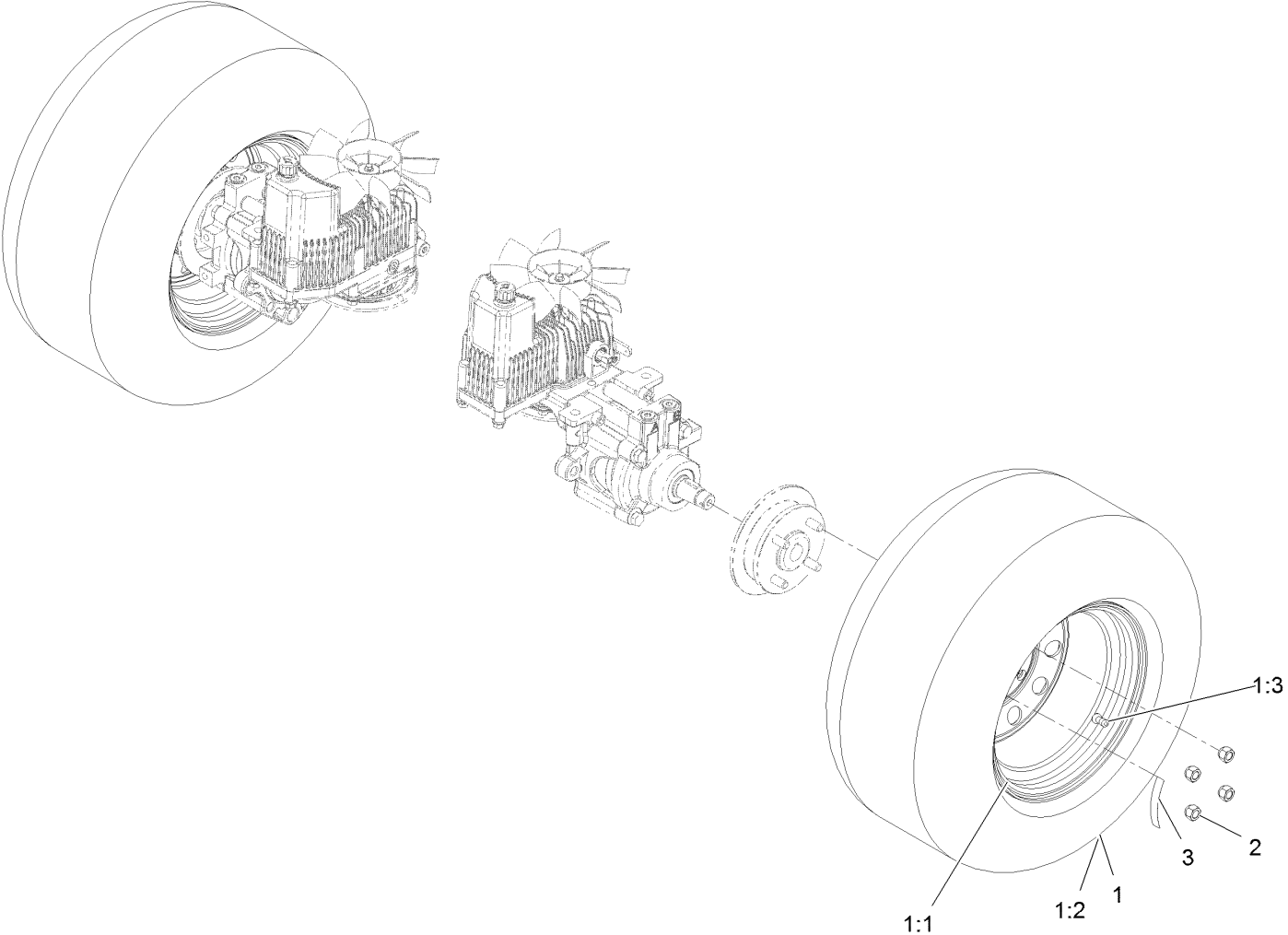

## Rear Wheel Assembly (continued)

| <i>Ref.</i> | <i>Part Number</i> | <i>Qty.</i> | <i>Description</i> | <i>Ref.</i> | <i>Part Number</i> | <i>Qty.</i> | <i>Description</i>             |
|-------------|--------------------|-------------|--------------------|-------------|--------------------|-------------|--------------------------------|
| 1           | 109-8972           | 2           | Wheel And Tire ASM | 2           | 242-50             | 8           | Nut-Lug 1/2-20                 |
| 1:1         | 1-633993           | 1           | Tire               | 3           | 126-2055           | 2           | Decal-Torque, Wheel Hub<br>Lug |
| 1:2         | 109-3156           | 1           | Rim                |             |                    |             |                                |
| 1:3         | 232-27             | 1           | Stem-Valve         |             |                    |             |                                |

# Park Brake Assembly

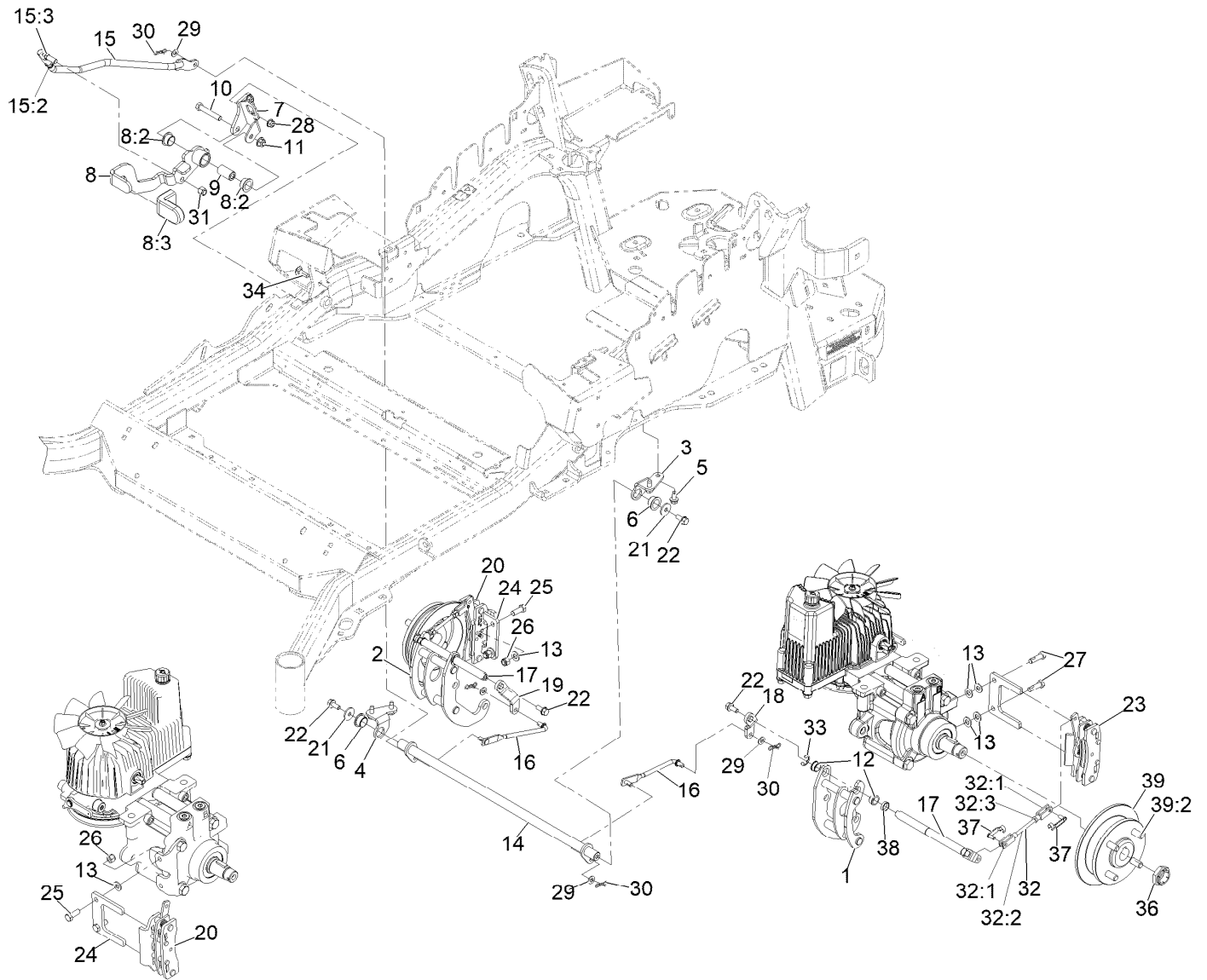

REAR VIEW OF  
RIGHT HAND HYDRO

## Park Brake Assembly (continued)

| <i>Ref.</i> | <i>Part Number</i> | <i>Qty.</i> | <i>Description</i>            | <i>Ref.</i> | <i>Part Number</i> | <i>Qty.</i> | <i>Description</i>        |
|-------------|--------------------|-------------|-------------------------------|-------------|--------------------|-------------|---------------------------|
| 1           | 126-4248           | 1           | Mount-Bellcrank, LH           | 19          | 126-3716           | 1           | Arm-Inner, RH             |
| 2           | 126-4249           | 1           | Mount-Bellcrank, RH           | 20          | 135-7440           | 1           | Caliper-Brake, RH         |
| 3           | 116-9681           | 1           | Mount-Pivot, LH               | 21          | 115-7109           | 2           | Washer-Flat               |
| 4           | 116-9682           | 1           | Mount-Pivot, RH               | 22          | 98-9940            | 4           | Screw-HHF                 |
| 5           | 32144-70           | 4           | Screw-HWH 5/16-18 X 3/4<br>Tf | 23          | 135-7441           | 1           | Caliper-Brake, LH         |
| 6           | 109-8054           | 2           | Bushing-Flanged               | 24          | 135-7828           | 2           | Plate-Mount, Brake        |
| 7           | 116-9096-01        | 1           | Bracket-Mount                 | 25          | 135-7915           | 2           | Screw-HH,                 |
| 8           | 135-7982           | 1           | Brake Lever ASM W/Grip<br>M-R | 26          | 112-0236           | 2           | Nut-Lock                  |
| 8:2         | 109-8054           | 2           | Bushing-Flanged               | 27          | 135-7890           | 2           | Screw-HH, Patch,          |
| 8:3         | 132-4749           | 1           | Grip-Lever                    | 28          | 104-8300           | 2           | Nut-Nyloc 5/16-18 Flg     |
| 9           | 116-9117           | 1           | Pivot-Handle, Brake           | 29          | 3256-23            | 4           | Washer-5/16 SAE           |
| 10          | 323-11             | 1           | Screw-HH 3/8-16 X 2 1/4       | 30          | 119-1415           | 4           | Pin-Cotter, Locking       |
| 11          | 104-8301           | 1           | Nut-Nyloc 3/8-16 Flg          | 31          | 3296-6             | 1           | Nut-Nyloc 3/8-24          |
| 12          | 126-6199           | 4           | Bushing                       | 32          | 126-7587           | 2           | Rear Linkage ASM          |
| 13          | 3256-24            | 6           | Washer-3/8 SAE                | 32:1        | 126-7588           | 2           | Yoke                      |
| 14          | 135-7800           | 1           | Shaft-Cross                   | 32:2        | 116-9069           | 1           | Linkage, Rear             |
| 15          | 135-7805           | 1           | ASM, Front Linkage            | 32:3        | 3220-1             | 1           | Nut-Jam 1/4-28            |
| 15:2        | 94-7572            | 1           | End-Tie Rod, RH               | 33          | 32120-19           | 2           | E-Ring                    |
| 15:3        | 3220-3             | 1           | Nut-Jam 3/8-24                | 34          | 3230-2             | 2           | Bolt-Carriage 5/16-18 X 1 |
| 16          | 142-6328           | 2           | Mid-Link, Short               | 36          | 116-1399           | 2           | Locknut                   |
| 17          | 126-4251           | 2           | Bellcrank                     | 37          | 126-6395           | 4           | Pin-Clevis, Spring        |
| 18          | 126-3715           | 1           | Arm-Inner, LH                 | 38          | 126-6200           | 2           | Spacer                    |
|             |                    |             |                               | 39          | 142-2701           | 2           | Wheel Hub ASM             |
|             |                    |             |                               | 39:2        | 116-1696           | 4           | Stud-Wheel                |

# Suspension Seat Assembly

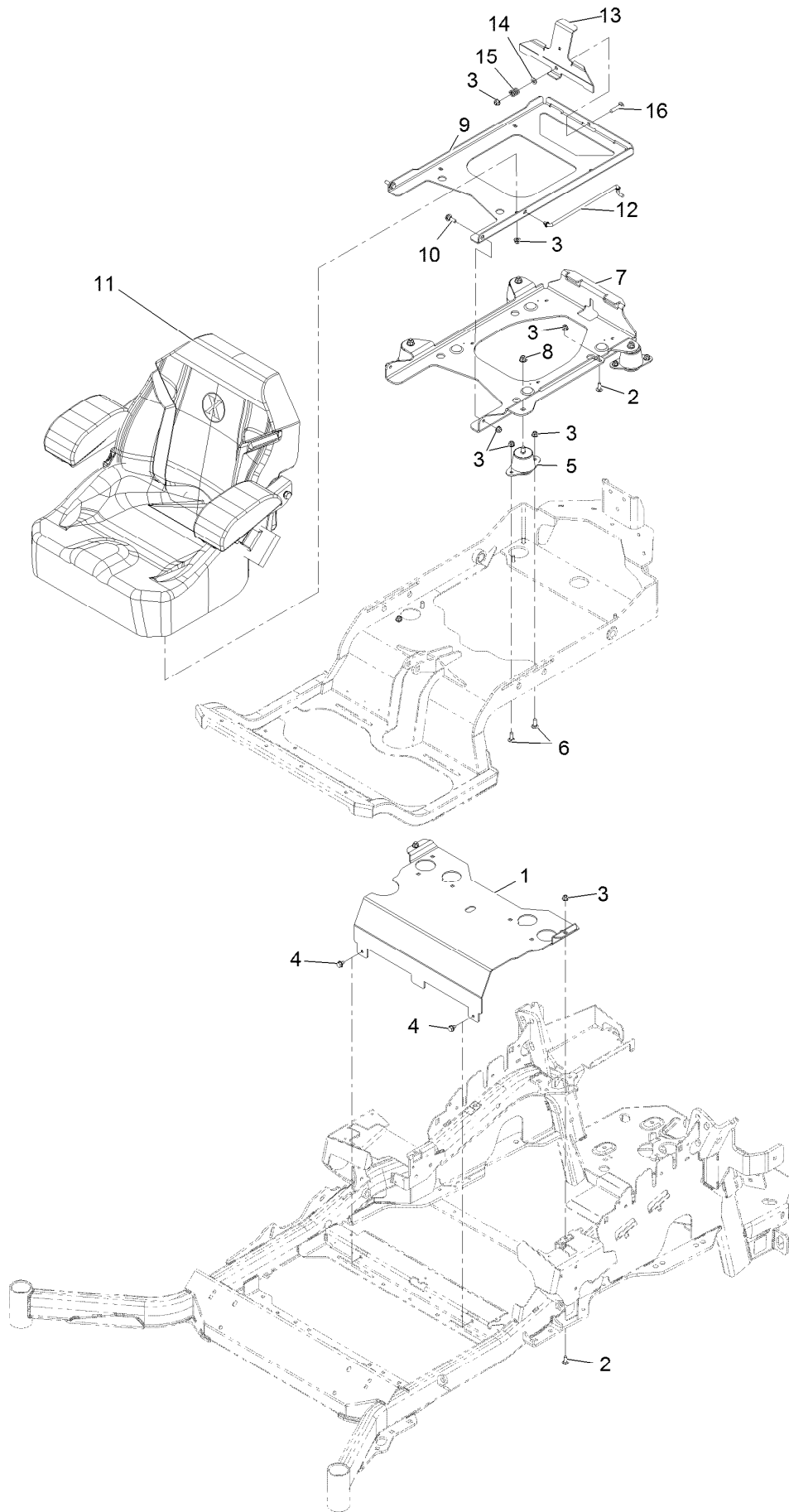



## Suspension Seat Assembly (continued)

| <i>Ref.</i> | <i>Part Number</i> | <i>Qty.</i> | <i>Description</i>                        | <i>Ref.</i> | <i>Part Number</i> | <i>Qty.</i> | <i>Description</i>               |
|-------------|--------------------|-------------|---|-------------|--------------------|-------------|----------------------------------|
| 1           | 116-2130-03        | 1           | Panel-Front, Seat Mount                   | 9           | 116-3859-03        | 1           | Plate-Frame, Seat                |
| 2           | 3230-23            | 3           | Bolt-Carriage 5/16-18 X 3/4<br>Short Neck | 10          | 116-1297           | 2           | Screw-Shoulder                   |
| 3           | 104-8300           | 18          | Nut-Nyloc 5/16-18 Flg                     | 11          | 126-5801           | 1           | Seat-Exmark Standard             |
| 4           | 9266934            | 2           | Screw-HWH 5/16 X 1/2 Tf                   | 12          | 116-0070           | 1           | Rod-Prop                         |
| 5           | 109-9034           | 4           | Isolator-Seat                             | 13          | 132-5088-03        | 1           | Plate-Latch, Seat                |
| 6           | 3230-10            | 8           | Bolt-Carriage 5/16-18 X 7/8               | 14          | 3256-23            | 1           | Washer-5/16 SAE                  |
| 7           | 131-6324-03        | 1           | Plate-Support, ISO Seat                   | 15          | 107-3017           | 1           | Spring-Compression               |
| 8           | 104-8301           | 4           | Nut-Nyloc 3/8-16 Flg                      | 16          | 3230-4             | 1           | Bolt-Carriage 5/16-18 X 1<br>1/2 |

# Seat W/Tracks Assembly No. 126-5801

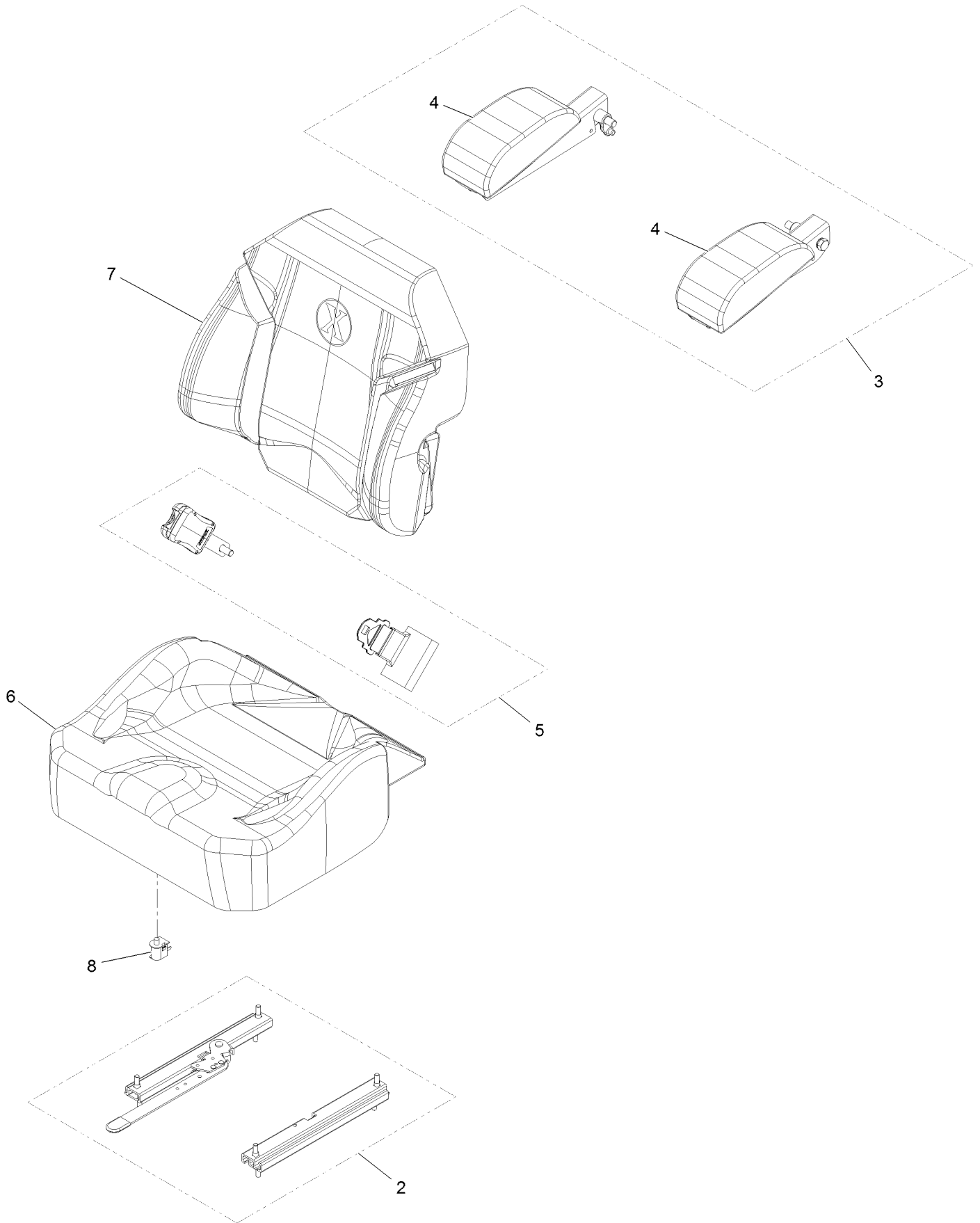

## Seat W/Tracks Assembly No. 126-5801 (continued)

| <i>Ref.</i> | <i>Part Number</i> | <i>Qty.</i> | <i>Description</i> | <i>Ref.</i> | <i>Part Number</i> | <i>Qty.</i> | <i>Description</i> |
|-------------|--------------------|-------------|--------------------|-------------|--------------------|-------------|--------------------|
| 2           | 109-9801           | 1           | Seat Track Set     | 6           | 126-6052           | 1           | Seat Cushion Cover |
| 3           | 116-8906           | 1           | Kit-Arm Rest Set   | 7           | 126-6051           | 1           | Seat Back Cover    |
| 4           | 116-8905           | 1           | Kit-Arm Rest Pads  | 8           | 82-2190            | 1           | Switch             |
| 5           | 109-9805           | 1           | Seat Belt Kit      |             |                    |             |                    |

# Fuel System Assembly

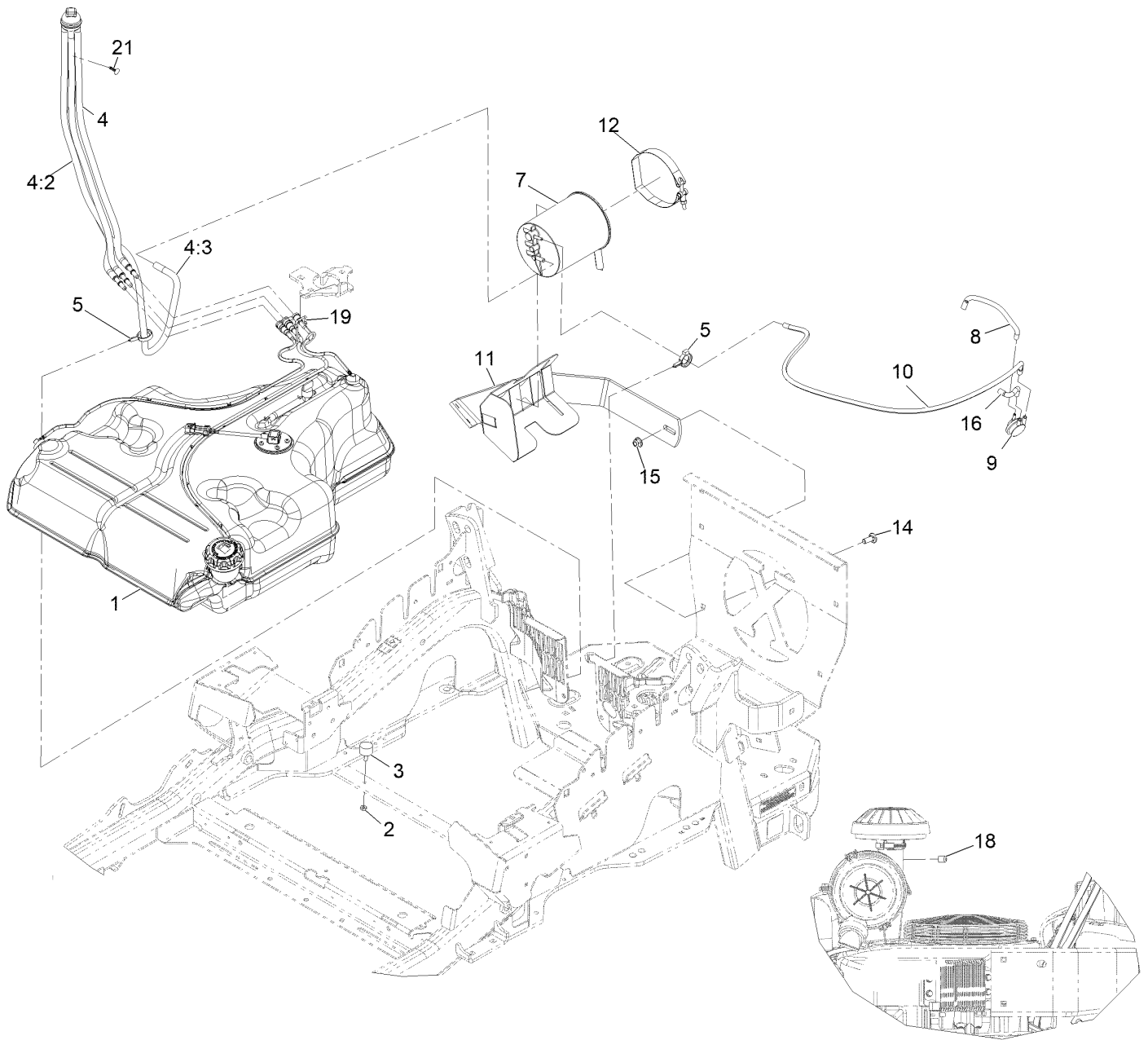

## Fuel System Assembly (continued)

| <i>Ref.</i> | <i>Part Number</i> | <i>Qty.</i> | <i>Description</i>      | <i>Ref.</i> | <i>Part Number</i> | <i>Qty.</i> | <i>Description</i>       |
|-------------|--------------------|-------------|-------------------------|-------------|--------------------|-------------|--------------------------|
| 1           | 135-0643           | 1           | Fuel Tank ASM           | 10          | 135-3417           | 1           | Hose,Vent,Formed         |
| 2           | 3218-1             | 2           | Nut-Jam 1/4-20          | 11          | 116-1433-03        | 1           | Mount-Canister           |
| 3           | 1-523420           | 2           | Bumper                  | 12          | 116-2228           | 1           | Clamp, T-Bolt            |
| 4           | 127-0583           | 1           | Fuel Manifold Vent ASM  | 14          | 3231-22            | 1           | Bolt-Carriage 3/8-16 X 1 |
| 4:2         | 109-0302           | 3           | Hose-Fuel Line 24"      | 15          | 104-8301           | 1           | Nut-Nyloc 3/8-16 Flg     |
| 4:3         | 108-5376           | 1           | Hose-Fuel               | 16          | 119-8502           | 1           | Hose-Vent, Formed        |
| 5           | 105-1853           | 2           | Clamp-Hose              | 18          | 116-4464           | 1           | Plug-Port                |
| 7           | 116-1442           | 1           | Canister-Carbon, 1200Cc | 19          | 116-6005           | 1           | Retainer-Line, Vapor     |
| 8           | 135-3415           | 1           | Hose-Vent,Formed        | 21          | 125-8067           | 1           | Plug-Plastic             |
| 9           | 116-2232           | 1           | Valve-Control, Vacuum   |             |                    |             |                          |

# Fuel Tank Assembly

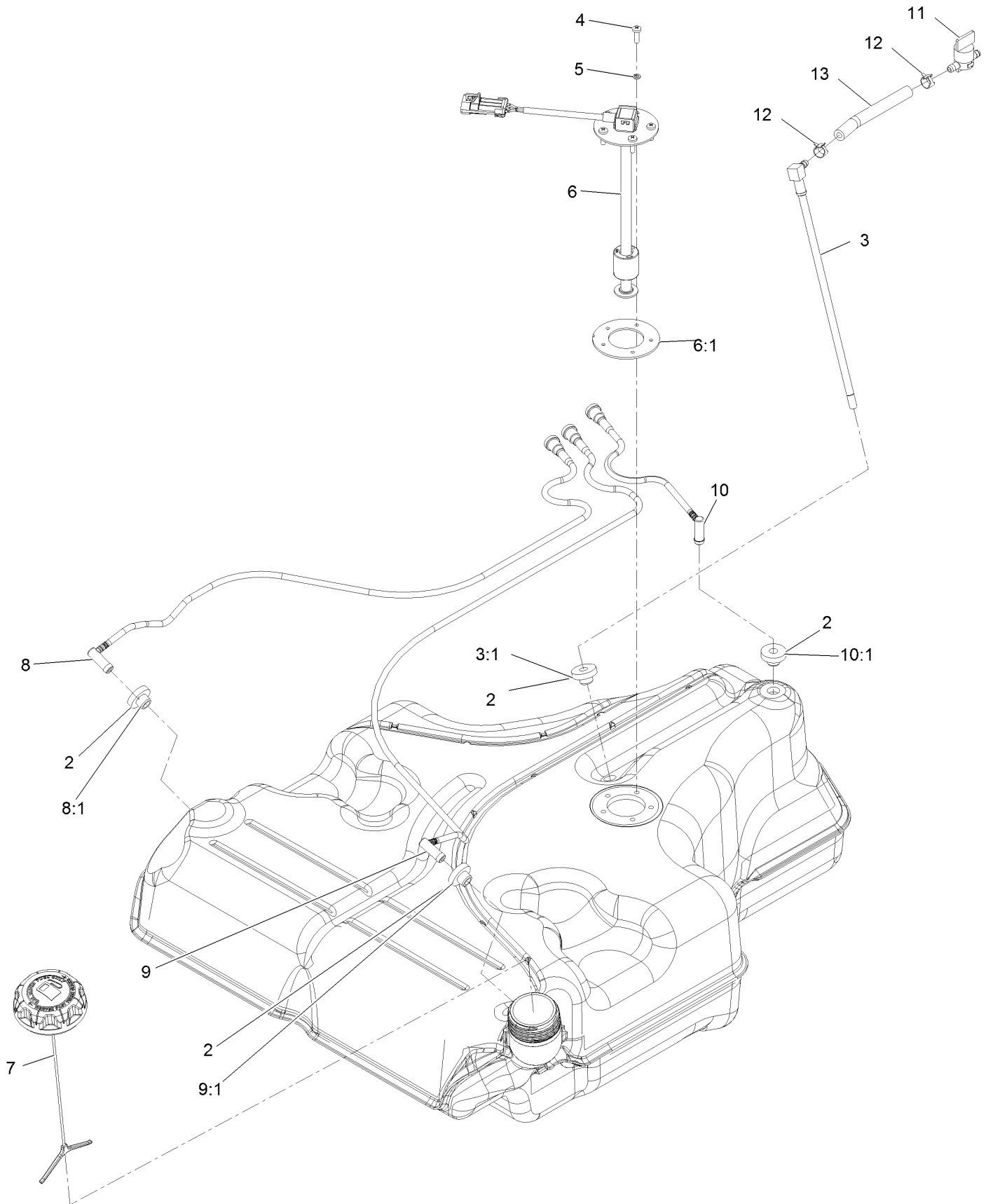

## Fuel Tank Assembly (continued)

| <i>Ref.</i> | <i>Part Number</i> | <i>Qty.</i> | <i>Description</i>              | <i>Ref.</i> | <i>Part Number</i> | <i>Qty.</i> | <i>Description</i>                |
|-------------|--------------------|-------------|---------------------------------|-------------|--------------------|-------------|-----------------------------------|
| 2           | 46-6560            | 4           | Bushing                         | 8:1         | 46-6560            | 1           | Bushing                           |
| 3           | 116-2459           | 1           | Fuel Line Kit (With Grommet)    | 9           | 116-2461           | 1           | LH Vent Line Kit (With Grommet)   |
| 3:1         | 46-6560            | 1           | Bushing                         | 9:1         | 46-6560            | 1           | Bushing                           |
| 4           | 3290-500           | 5           | Screw-PPH                       | 10          | 116-2462           | 1           | Rear Vent Line Kit (With Grommet) |
| 5           | 3253-17            | 5           | Washer-Lock                     | 10:1        | 46-6560            | 1           | Bushing                           |
| 6           | 126-3913           | 1           | Float-Sender, Fuel              | 11          | 1-603770           | 1           | Valve-Fuel                        |
| 6:1         | 126-3950           | 1           | Gasket-Sender                   | 12          | 2412-98            | 2           | Clamp-Hose                        |
| 7           | 126-1789           | 1           | Cap-Fuel, Ratcheting            | 13          | 109-0650           | 1           | Hose-Fuel                         |
| 8           | 116-2460           | 1           | RH Vent Line Kit (With Grommet) |             |                    |             |                                   |

# Engine Assembly

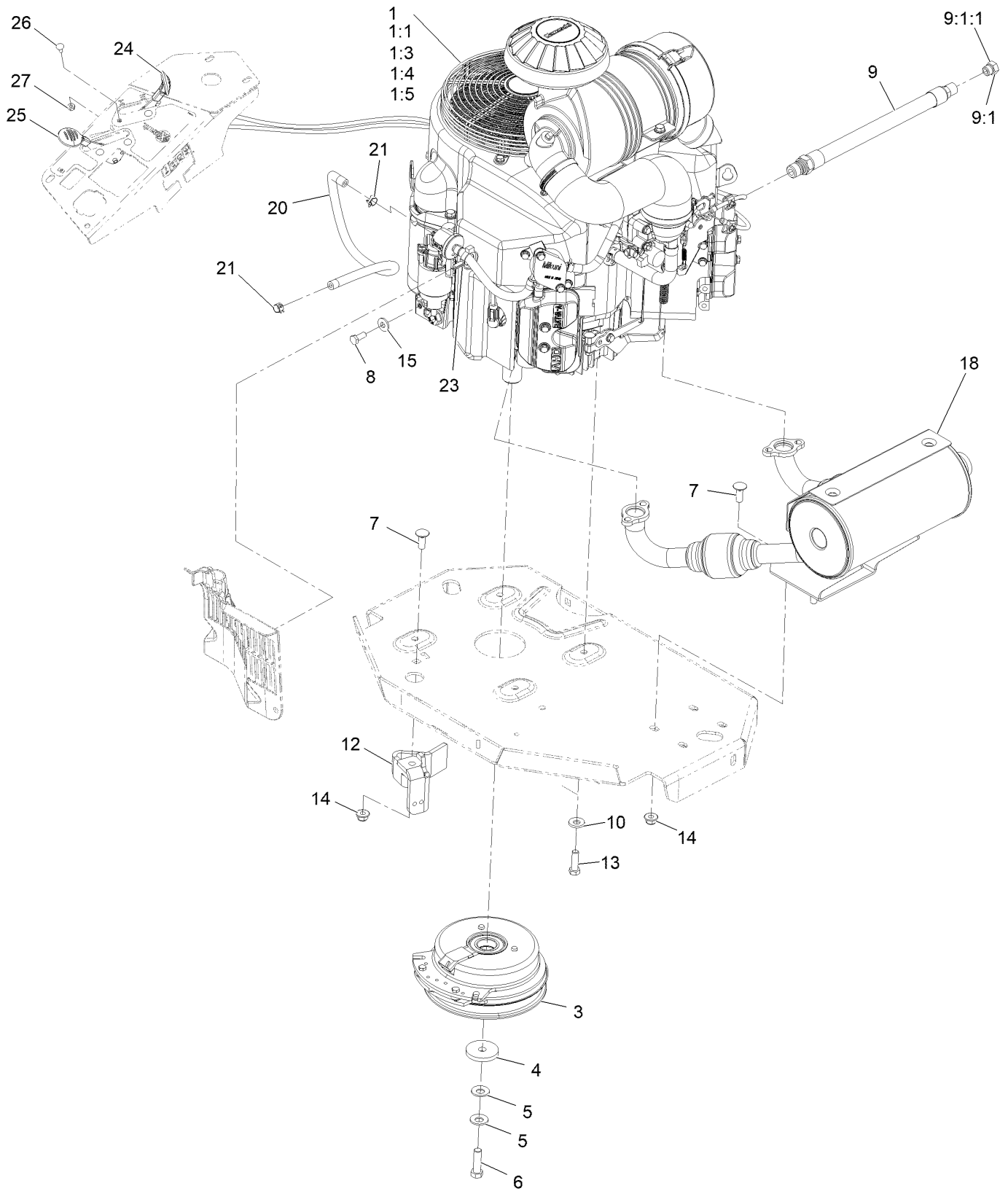



## Engine Assembly (continued)

| <i>Ref.</i> | <i>Part Number</i> | <i>Qty.</i> | <i>Description</i>                          | <i>Ref.</i> | <i>Part Number</i> | <i>Qty.</i> | <i>Description</i>         |
|-------------|--------------------|-------------|---|-------------|--------------------|-------------|----------------------------|
| 1           |                    | 1           | Engine-Kawasaki Fx801V ▲<br>◆               | 9:1         | 353-508            | 1           | Plug-W/O-Ring ●            |
| 1:1         |                    | 1           | Kawasaki 49065-2078<br>Engine Oil Filter ▲◆ | 9:1:1       | 237-42             | 1           | O-Ring                     |
| 1:3         |                    | 1           | Kawasaki 49019-0031 Fuel<br>Filter ▲◆       | 10          | 98-5975            | 4           | Washer-Spring Disc 3/8     |
| 1:4         |                    | 1           | Kawasaki 11013-7039<br>Safety Filter ▲◆     | 12          | 116-2612-01        | 1           | Clutch-Anchor              |
| 1:5         |                    | 1           | Kawasaki 11013-7038 Air<br>Filter ▲◆        | 13          | 323-7              | 4           | Screw-HH 3/8-16 X 1 1/4    |
| 3           | 116-1620           | 1           | Clutch Kit                                  | 14          | 104-8301           | 5           | Nut-Nyloc 3/8-16 Flg       |
| 4           | 109-6919           | 1           | Washer-Clutch                               | 15          | 1-303334           | 1           | Washer-Spring Disc 5/16    |
| 5           | 1-603610           | 2           | Washer-Spring Disc 7/16                     | 18          | 135-7562           | 1           | Kit, Muffler               |
| 6           | 109-9761           | 1           | Screw-HH 7/16-20 X 1 1/2<br>W/Loctite □     | 20          | 109-0298           | 1           | Line-Fuel                  |
| 7           | 3231-22            | 5           | Bolt-Carriage 3/8-16 X 1                    | 21          | 2412-98            | 2           | Clamp-Hose                 |
| 8           | 33114-020          | 1           | Screw-HH M8-1.25 X 20Mm                     | 23          | 105-1853           | 2           | Clamp-Hose                 |
| 9           | 116-4924           | 1           | Asm-Hose Oil Drain W/Plug<br>■              | 24          | 109-8167           | 1           | ASM, Choke Cable           |
|             |                    |             |   | 25          | 116-1972           | 1           | ASM,Throttle Cable         |
|             |                    |             |   | 26          | 1-807513           | 4           | Bolt-Carriage #10-24 X 1/2 |
|             |                    |             |   | 27          | 3296-2             | 4           | Nut-Nyloc #10-24           |

● Torque to 24-26 ft-lb

▲ Not serviced separately

□ Use Pro-Lock, Nut Type (P/N 1-840022, .5ml tube) on threads.

■ Torque to 23-29 ft-lb

◆ Obtain parts from [www.kawpower.com](http://www.kawpower.com)

# Hydraulic Assembly

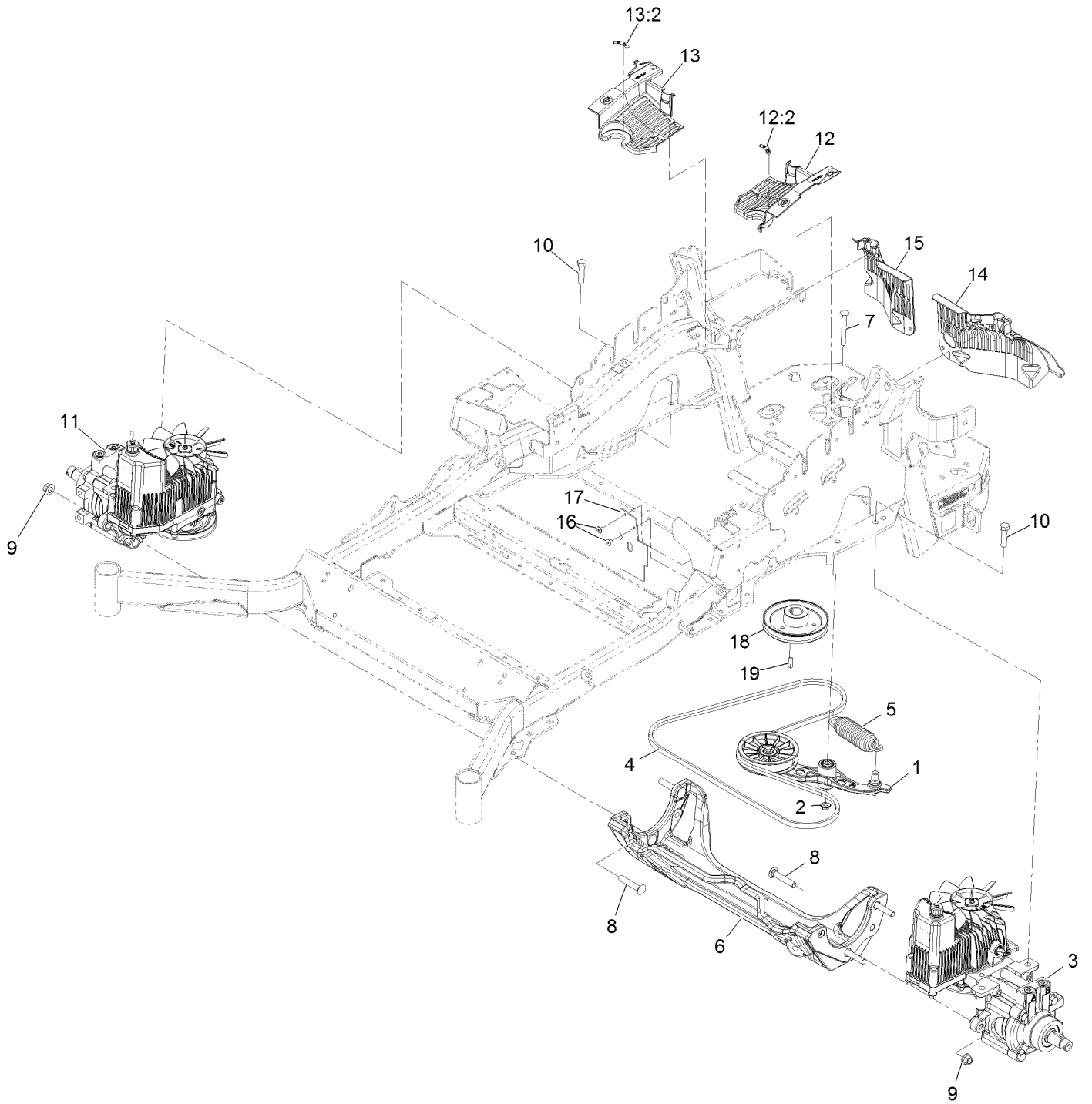

## Hydraulic Assembly (continued)

| <i>Ref.</i> | <i>Part Number</i> | <i>Qty.</i> | <i>Description</i>                       | <i>Ref.</i> | <i>Part Number</i> | <i>Qty.</i> | <i>Description</i>        |
|-------------|--------------------|-------------|--|-------------|--------------------|-------------|---------------------------|
| 1           | 116-1255           | 1           | Pump Idler ASM                           | 12:2        | 116-8726           | 1           | Decal-Oil, Hydro          |
| 2           | 109-6658           | 1           | Nut-Nyloc 3/8-16 Flg                     | 13          | 116-0171           | 1           | RH Hydro Guard ASM        |
| 3           | 135-7905           | 1           | Hydro-LH                                 | 13:2        | 116-8726           | 1           | Decal-Oil, Hydro          |
| 4           | 126-9835           | 1           | Belt-V                                   | 14          | 109-9057           | 1           | Guard-Hydro, Rear (LH)    |
| 5           | 116-6317           | 1           | Spring-Extension                         | 15          | 109-9058           | 1           | Guard-Hydro, Rear (RH)    |
| 6           | 116-7558           | 1           | Cradle-Hydro                             | 16          | 1-803035           | 2           | Rivet 3/16 X 1/4          |
| 7           | 116-1502           | 1           | Bolt-Carriage Shoulder<br>3/8-16 X 3 1/2 | 17          | 116-2362           | 1           | Deflector-Air Flow        |
| 8           | 126-0095           | 6           | Bolt-Carriage 1/2-13 X 2 3/4             | 18          | 109-9905           | 1           | Sheave                    |
| 9           | 99-5107            | 6           | Nut-Lock 1/2-13                          | 19          | 1-807259           | 1           | Key-Machine 1/4 X 1/4 X 1 |
| 10          | 325-8              | 4           | Screw-HH 1/2-13 X 1 1/4                  | 99          | 109-9828           | 1           | Oil-HYD, (Quart) ●        |
| 11          | 135-7906           | 1           | Hydro-RH                                 | 99          | 116-0164           | 1           | Filter-Hydro ●            |
| 12          | 116-0170           | 1           | LH Hydro Guard ASM                       | 99          | 116-1218           | 1           | Oil-HYD, 1 Gallon ●       |
|             |                    |             |  | 99          | 126-8103           | 1           | Kit, Hydro Service ●      |

● Not illustrated

# LH Hydro Assembly No. 135-7905

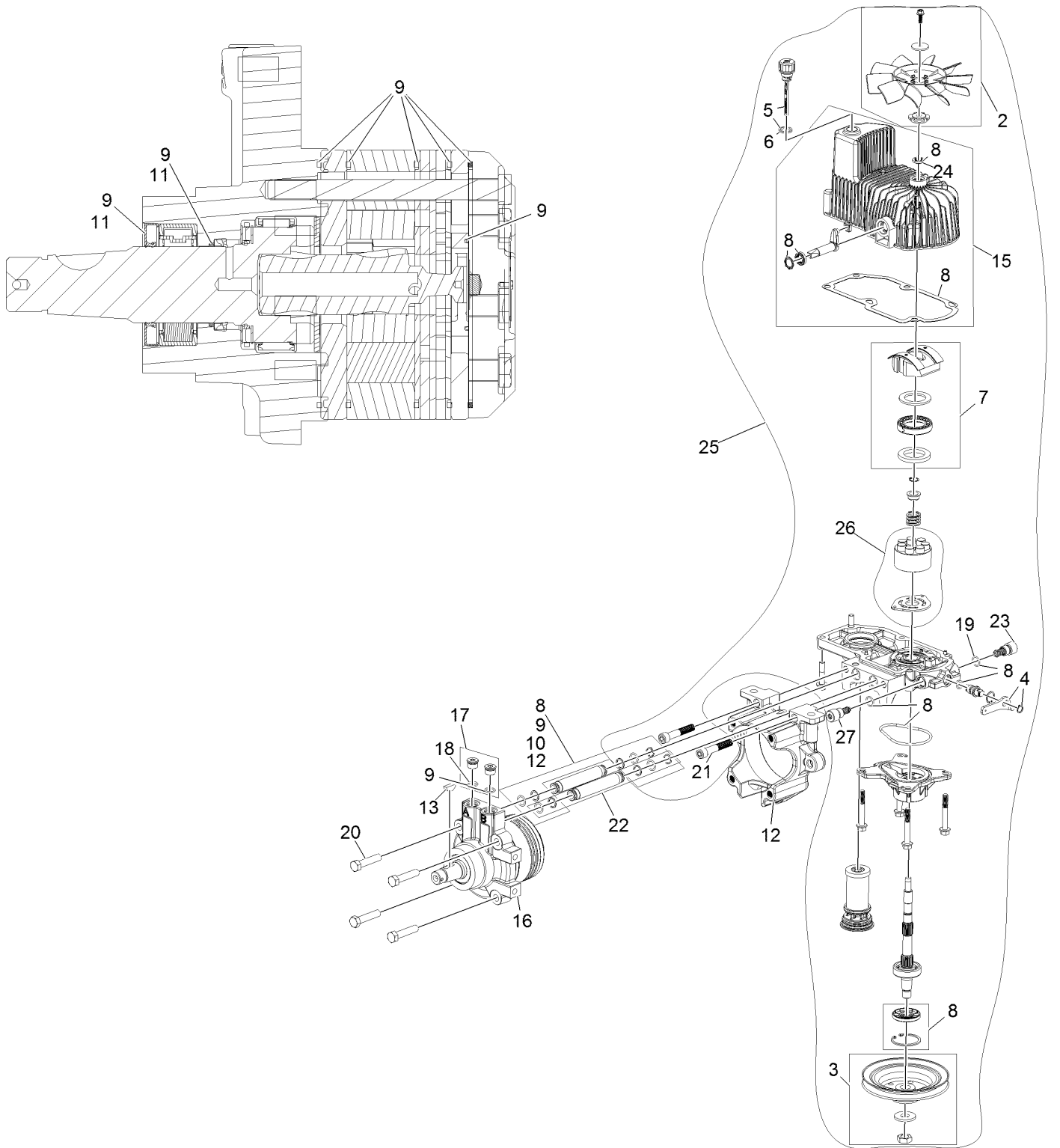

## LH Hydro Assembly No. 135-7905 (continued)

| <i>Ref.</i> | <i>Part Number</i> | <i>Qty.</i> | <i>Description</i>        | <i>Ref.</i> | <i>Part Number</i> | <i>Qty.</i> | <i>Description</i>                |
|-------------|--------------------|-------------|---------------------------|-------------|--------------------|-------------|-----------------------------------|
| 2           | 142-3603           | 1           | Kit, 7.8 In Fan           | 17          | 116-7901           | 1           | Magnetic Plugs Service Kit        |
| 3           | 116-0234           | 1           | Pulley Kit                | 18          | 76-1900            | 2           | O-Ring                            |
| 4           | 116-0235           | 1           | Handle                    | 19          | 116-8662           | 1           | O-Ring-Valve, Check               |
| 5           | 116-0236           | 1           | Dipstick                  | 20          | 116-8974           | 4           | Screw HH                          |
| 6           | 116-0237           | 1           | Gasket                    | 21          | 116-8975           | 2           | Screw-HSH                         |
| 7           | 116-1367           | 1           | Swash Block Kit           | 22          | 116-9922           | 2           | Hydraulic Tube Kit                |
| 8           | 142-3604           | 1           | Kit, Pump Seal            | 23          | 126-7467           | 1           | Shock Valve, 16Cc Hydro           |
| 9           | 116-1369           | 1           | Motor Seal Kit            | 24          | 126-7711           | 1           | Seal-Drive, Fan                   |
| 10          | 116-1370           | 1           | Tube Seal Kit             | 25          | 142-3607           | 1           | Kit, Pump Section 16Cc LH         |
| 11          | 116-1371           | 1           | Output Shaft Seal Kit     | 26          | 142-4501           | 1           | Kit - 16Cc Port Plate, Rotate Grp |
| 12          | 116-5469           | 1           | Cup-Nose                  |             |                    |             |                                   |
| 13          | 3257-42            | 1           | Key-Woodruff              | 27          | 142-4458           | 1           | Shock Valve Orificed 3300         |
| 15          | 142-4460           | 1           | Kit, Housing-Hydro LH     | 99          | 116-1373           | 1           | Flow Test Kit ●                   |
| 16          | 116-8917           | 1           | Motor-Hydraulic, LH 280Cc | 99          | 116-4245           | 1           | Puller-Pulley                     |

● Not illustrated

# RH Hydro Assembly No. 135-7906

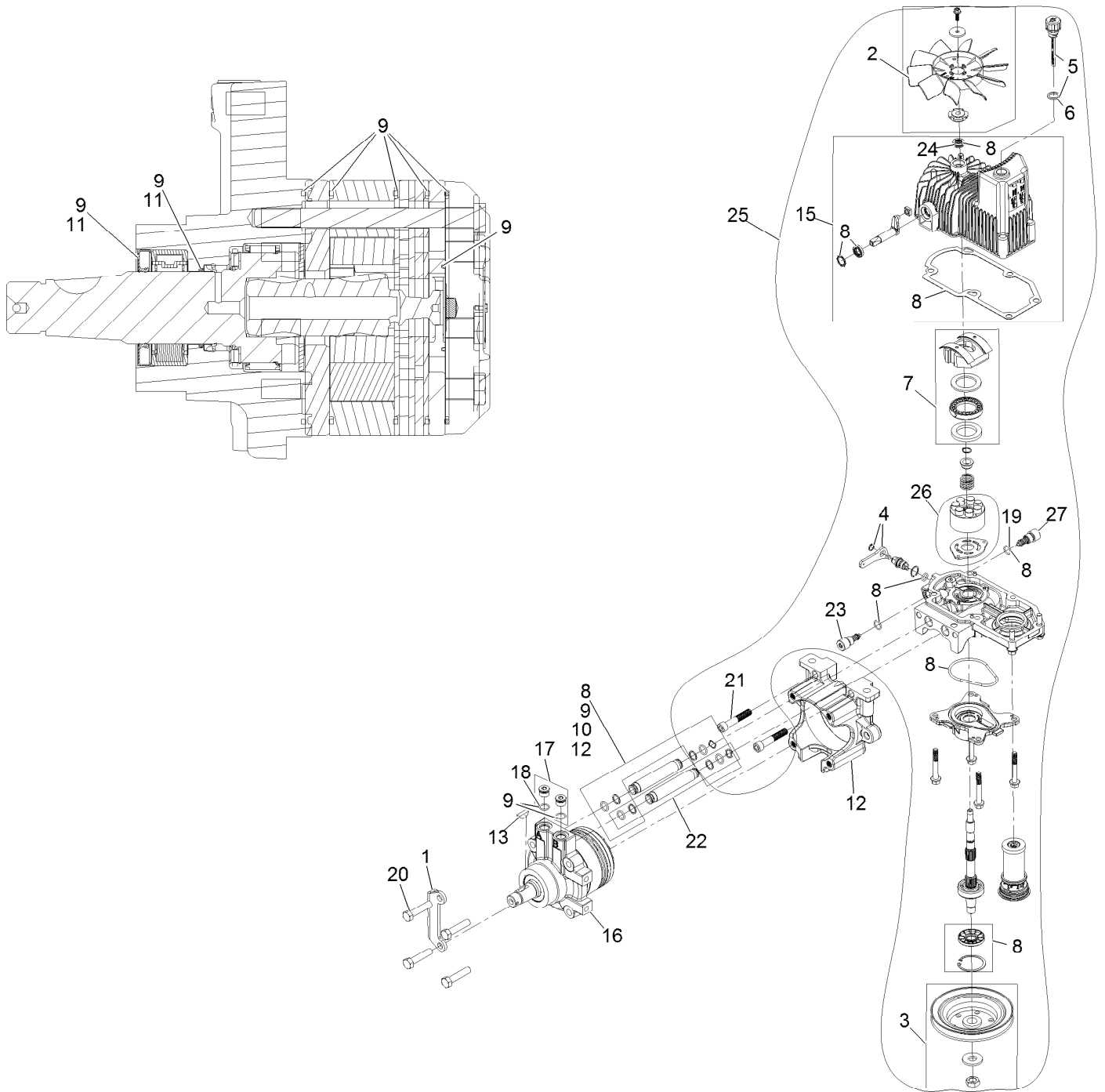

## RH Hydro Assembly No. 135-7906 (continued)

| <i>Ref.</i> | <i>Part Number</i> | <i>Qty.</i> | <i>Description</i>        | <i>Ref.</i> | <i>Part Number</i> | <i>Qty.</i> | <i>Description</i>                |
|-------------|--------------------|-------------|---------------------------|-------------|--------------------|-------------|-----------------------------------|
| 1           | 135-7827           | 1           | Plate, Horse Shoe Mount   | 17          | 116-7901           | 1           | Magnetic Plugs Service Kit        |
| 2           | 142-3603           | 1           | Kit, 7.8 In Fan           | 18          | 76-1900            | 2           | O-Ring                            |
| 3           | 116-0234           | 1           | Pulley Kit                | 19          | 116-8662           | 2           | O-Ring-Valve, Check               |
| 4           | 116-0235           | 1           | Handle                    | 20          | 116-8974           | 4           | Screw HH                          |
| 5           | 116-0236           | 1           | Dipstick                  | 21          | 116-8975           | 2           | Screw-HSH                         |
| 6           | 116-0237           | 1           | Gasket                    | 22          | 116-9922           | 2           | Hydraulic Tube Kit                |
| 7           | 116-1367           | 1           | Swash Block Kit           | 23          | 126-7467           | 1           | Shock Valve, 16Cc Hydro           |
| 8           | 142-3604           | 1           | Kit, Pump Seal            | 24          | 126-7711           | 1           | Seal-Drive, Fan                   |
| 9           | 116-1369           | 1           | Motor Seal Kit            | 25          | 142-3606           | 1           | Kit, Pump Section 16Cc RH         |
| 10          | 116-1370           | 1           | Tube Seal Kit             | 26          | 142-4501           | 1           | Kit - 16Cc Port Plate, Rotate Grp |
| 11          | 116-1371           | 1           | Output Shaft Seal Kit     |             |                    |             |                                   |
| 12          | 116-5469           | 1           | Cup-Nose                  | 27          | 142-4458           | 1           | Shock Valve Orificed 3300         |
| 13          | 3257-42            | 1           | Key-Woodruff              | 99          | 116-1373           | 1           | Flow Test Kit ●                   |
| 15          | 142-4461           | 1           | Kit, Housing-Hydro RH     | 99          | 116-4245           | 1           | Puller-Pulley                     |
| 16          | 116-8918           | 1           | Motor-Hydraulic, RH 280Cc |             |                    |             |                                   |

● Not illustrated

# Pump Idler Assembly No. 116-1255

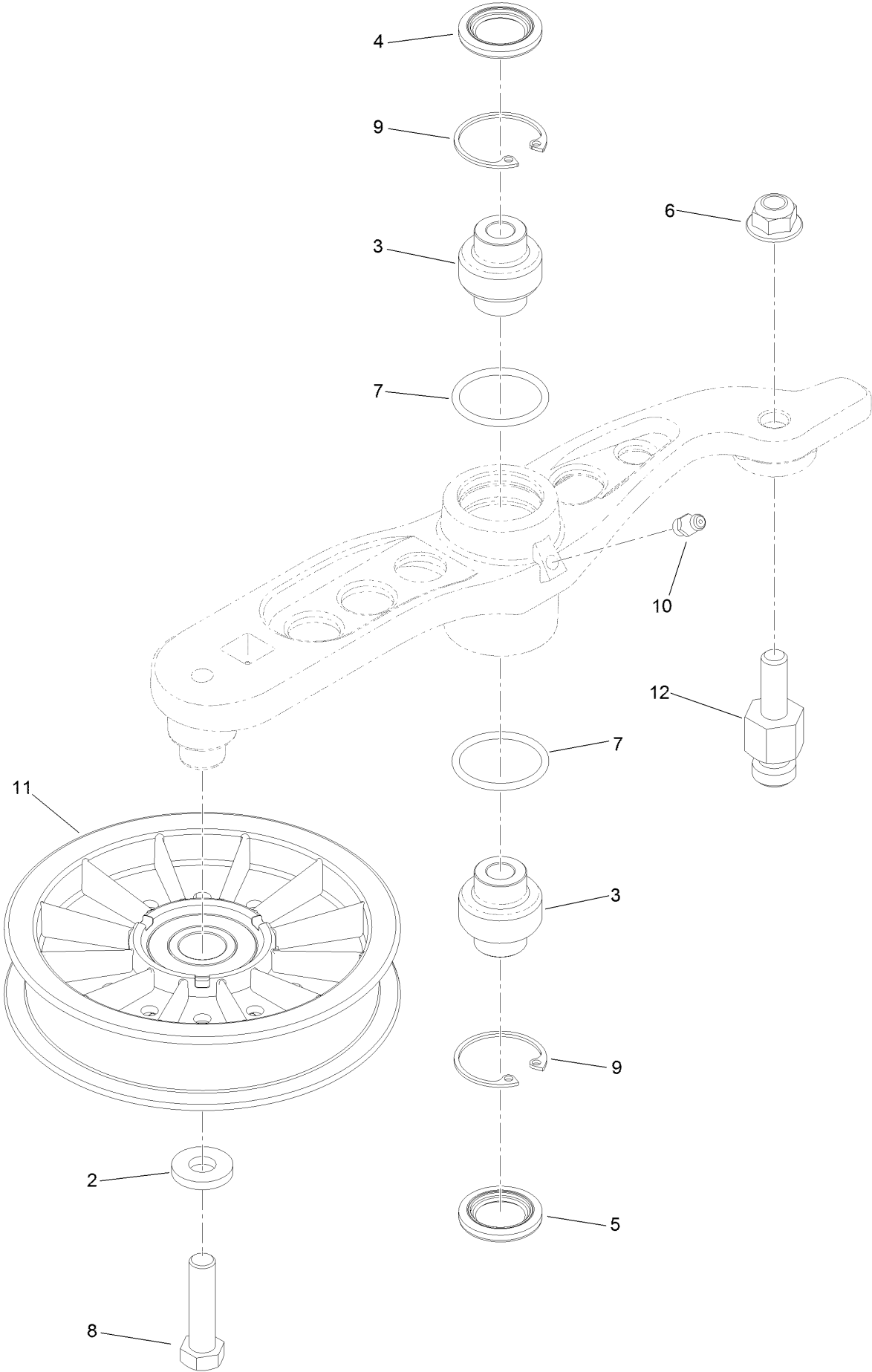



## Pump Idler Assembly No. 116-1255 (continued)

| <i>Ref.</i> | <i>Part Number</i> | <i>Qty.</i> | <i>Description</i> | <i>Ref.</i> | <i>Part Number</i> | <i>Qty.</i> | <i>Description</i> |
|-------------|--------------------|-------------|--------------------|-------------|--------------------|-------------|--------------------|
| 2           | 43-0940            | 1           | Spacer             | 8           | 323-8              | 1           | Screw-HH           |
| 3           | 103-3504           | 2           | Bearing-Spherical  | 9           | 32120-10           | 2           | Ring-Snap          |
| 4           | 103-3505           | 1           | Seal-Lip, Double   | 10          | 302-19             | 1           | Fitting-Grease     |
| 5           | 103-3506           | 1           | Seal-Lip, Single   | 11          | 109-8076           | 1           | Pulley-Idler       |
| 6           | 109-6658           | 1           | Nut-Flange, NI     | 12          | 132-4724           | 1           | Pin-Anchor, Spring |
| 7           | 106-7159           | 2           | O-Ring             |             |                    |             |                    |

# Electrical Assembly

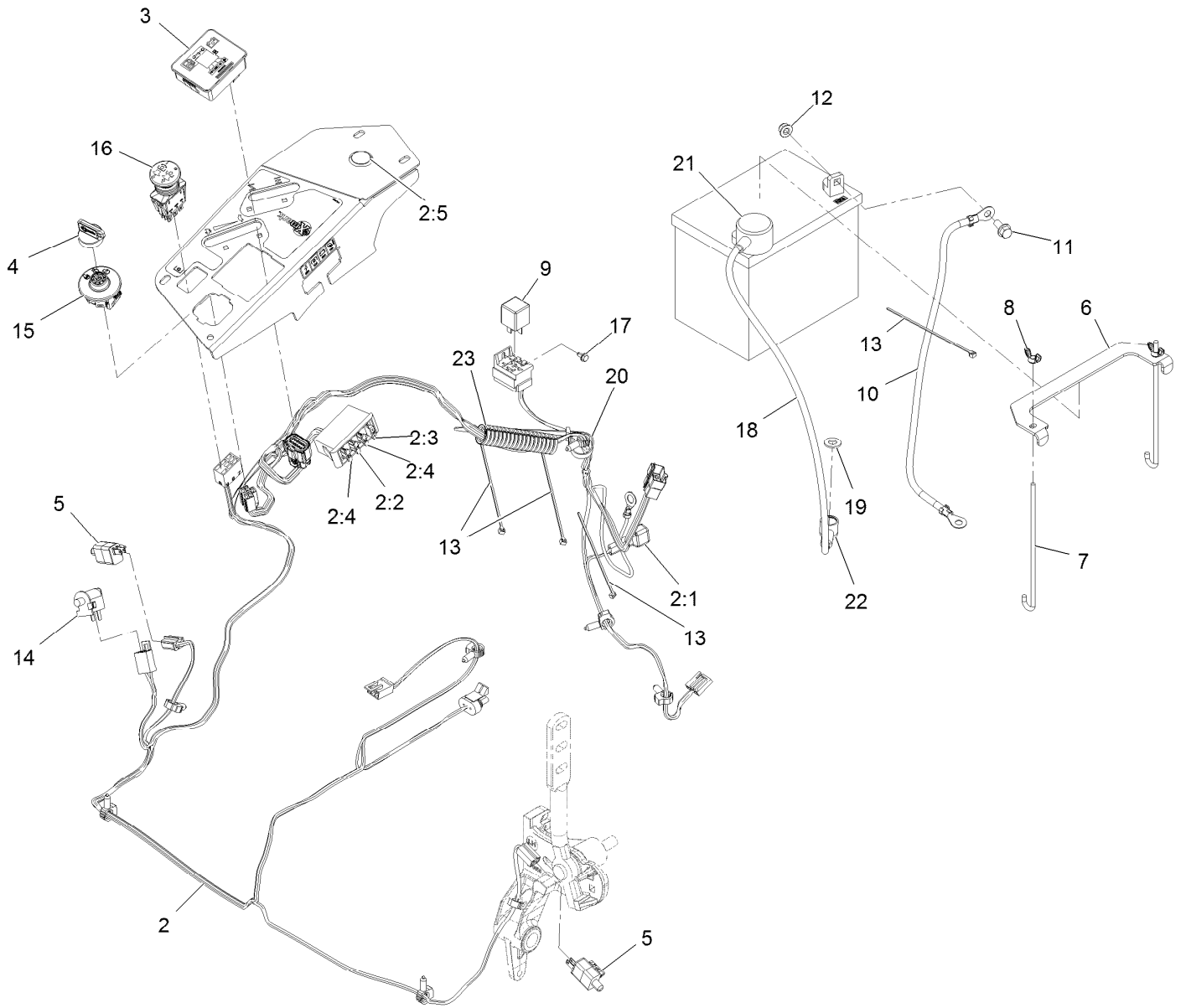

## Electrical Assembly (continued)

| <i>Ref.</i> | <i>Part Number</i> | <i>Qty.</i> | <i>Description</i>      | <i>Ref.</i> | <i>Part Number</i> | <i>Qty.</i> | <i>Description</i>         |
|-------------|--------------------|-------------|-------------------------|-------------|--------------------|-------------|----------------------------|
| 2           | 116-6009           | 1           | Harness-Wire, Main ●    | 10          | 114-1218           | 1           | Cable-Battery, Negative    |
| 2:1         | 103-3895           | 1           | Diode                   | 11          | 3234-5             | 2           | Screw-HH Flg 5/16-18 X 3/4 |
| 2:2         | 218-578            | 1           | Fuse-Blade, 10 Amp      | 12          | 104-8300           | 2           | Nut-Nyloc 5/16-18 Flg      |
| 2:3         | 109355             | 1           | Fuse-Blade, 15 Amp      | 13          | 1-303287           | 5           | Tie-Cable 5 1/2 (Small)    |
| 2:4         | 109102             | 2           | Fuse-Blade, 25 Amp      | 14          | 82-2190            | 1           | Switch                     |
| 2:5         | 116-0053           | 1           | Cap-Plug                | 15          | 137-4100           | 1           | Switch-Ignition            |
| 3           | 117-3882           | 1           | Fuel/Hour Meter ASM     | 16          | 135-3653           | 1           | Switch, PTO 10A            |
| 4           | 1-603511           | 1           | Key-Ignition            | 17          | 104-2065           | 1           | Screw-HWH #10-24 X 3/8     |
| 4           | 103-2106           | 1           | Key-Exmark Logo         | 18          | 115-3864           | 1           | Cable-Battery, Positive    |
| 5           | 110-6765           | 2           | Switch                  | 19          | 3256-24            | 1           | Washer-3/8 SAE             |
| 6           | 116-0042-03        | 1           | Strap-Tie Down, Battery | 20          | 3290-378           | 1           | Tie-Cable                  |
| 7           | 1-633651           | 2           | Bolt-Holddown           | 21          | 109-2407           | 1           | Insulator-Battery          |
| 8           | 1-543792           | 2           | Wingnut-Nyloc 1/4-20    | 22          | 1-543393           | 1           | Insulator-Solenoid         |
| 9           | 1-643275           | 1           | Relay-12Vdc 40 Amp      | 23          | 131-8846           | 1           | Cover-Hose                 |

● Use dielectric grease on all unsealed connectors and terminals only. Do not apply in sealed connectors.

**Notes:**

**Notes:**

**Notes:**



# MAXIMIZE THE PERFORMANCE OF YOUR EXMARK MACHINE.



## EXMARK® PREMIUM ENGINE OIL

Exmark now offers a family of engine oil viscosities to perform well in any environment. Each viscosity has the same synthetic formulation to give you what you need in punishing conditions. We designed each grade to the highest quality, making it ideal even for diesel applications. Coupled with Exmark Premium Fuel Treatment, we have the performance products to make your machine hum.

### EXMARK PREMIUM ENGINE OIL SAE 30/10W-30

- Meets zero shear requirements of a straight grade SAE 30 as well as the cold temp properties of a 10W-30.
- Most versatile oil in the industry.
- Superior corrosion protection over conventional oil - even in corrosive, humid environments.

### EXMARK PREMIUM ENGINE OIL SAE 20W-50

- Perfect for your big block engine, or any application in severe service.
- Same full synthetic formulation as all other Exmark Premium viscosities.
- Also effective for use in severe service small block engines.

### EXMARK PREMIUM ENGINE OIL SAE 10W-50

- Full synthetic formulation gives you peak performance. Don't settle for less.
- Wide span multi-grade combines easy starting in cold weather with maximum protection in high temperature operation.
- Reduce friction & wear over standard mineral formulations.

### EXMARK PREMIUM ENGINE OIL SAE 0W-40

- The perfect choice for when the weather turns cold or unpredictable, and your Exmark UTV has to perform.
- Commercial quality for severe service.
- Advanced additive package helps prevent corrosion from long-term storage.

### EXMARK PREMIUM ENGINE OIL UTV FORMULATION

- 4-cycle high-temp formulation.
- Heavier viscosity, full synthetic, perfect for your UTV.

### EXMARK PREMIUM UTV EXTREME CONDITIONS GEAR OIL

- SAE 80W-90, designed to keep your UTV performing at its peak.
- Shear stable, hypoid gear lube.
- Includes a premium additive system to combat wear, oxidation, rust & corrosion.

**Available from your local Exmark dealer. Find your closest dealer at [exmark.com](http://exmark.com)**

## EXMARK ACCESSORIES AND OPTIONS\*

### MID-MOUNT RIDING ACCESSORIES AND OPTIONS

|                                    |                                 |
|------------------------------------|---------------------------------|
| CUSTOM RIDE SEAT SUSPENSION SYSTEM | OPERATOR CONTROLLED DISCHARGE   |
| FULL SUSPENSION SEAT               | SUN SHADE                       |
| DECK LIFT ASSIST KIT               | TRASH CONTAINER                 |
| HITCH KIT                          | TURF STRIPER                    |
| LIGHT KIT                          | ULTRA VAC COLLECTION SYSTEM     |
| 12V POWER PORT                     | ULTRA VAC QUICK DISPOSAL SYSTEM |
| MICRO-MULCH SYSTEM                 |                                 |

### OUT-FRONT RIDING ACCESSORIES AND OPTIONS

|                                    |                                 |
|------------------------------------|---------------------------------|
| CUSTOM RIDE SEAT SUSPENSION SYSTEM | SNOW BLADE                      |
| DUAL-TAIL WHEEL                    | SNOWBLOWER                      |
| FLOOR PAN EXTENDER                 | SUN SHADE                       |
| HITCH KIT                          | TRASH CONTAINER                 |
| LIGHT KIT                          | ULTRA VAC COLLECTION SYSTEM     |
| MICRO-MULCH SYSTEM                 | ULTRA VAC QUICK DISPOSAL SYSTEM |
| ROLL OVER PROTECTION SYSTEM (ROPS) | WEATHER CAB                     |

### WALK-BEHIND ACCESSORIES AND OPTIONS

|                    |              |
|--------------------|--------------|
| GRASS CATCHER      | TURF STRIPER |
| MICRO-MULCH SYSTEM | STANDON      |

\*Some accessories and options not available for some models.

Place Model No. and Serial No.  
Label Here (Included in the Literature  
Pack) or Fill in Below

Model No. \_\_\_\_\_

Serial No. \_\_\_\_\_

Date Purchased \_\_\_\_\_

Engine Model No. and Spec. No. \_\_\_\_\_

Engine Serial No. (E/No) \_\_\_\_\_

© 2021 Exmark Mfg. Co., Inc.  
415 Industrial Row  
Beatrice, NE 68310  
All Rights Reserved

Part No. 4505-751 Rev. A  
(402) 223-6375  
Fax (402) 223-5489  
Printed in the USA.

