

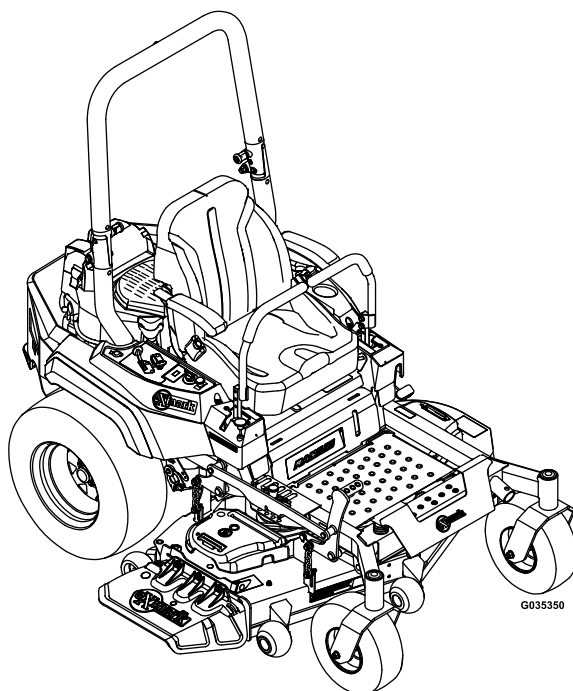

RADIUS® S-SERIES

Model No. RAS651GKA483A3—Serial No. 411294212 and Up

Picture below may not reflect actual product.



Parts Manual

Ordering Replacement Parts

To order replacement parts, please supply the part number, the quantity, and the description of each part desired.

Understanding Reference Numbers

Each identified part in an illustration has a reference number. The reference number for a part also appears in the parts list, along with other information about the part.

This catalog uses two special reference number formats, one to indicate parts in a service assembly and another to indicate the quantity of a given part in an illustration.

Service Assembly Reference Numbers

Parts in service assemblies have reference numbers in the form a:b. The a represents the reference number of the entire service assembly and the b represents a sequential number unique to each part within the service assembly.

For example, a wheel assembly might be identified by reference number 6, the tire by 6:1, the valve by 6:2, and the wheel by 6:3. When you order the assembly identified by reference number 6, you receive all parts identified by reference numbers 6:1, 6:2, and 6:3. However, you may also order any part individually. Reference numbers of this type appear in illustration and in parts lists.

Reference Numbers Indicating Quantity

In an illustration, if a reference number indicates more than one part, the reference number has the form nX y. The n represents the quantity of the part, the X is the multiplication symbol, and the y represents the reference number.

For example, in an illustration, the reference number 2X 37 means that two of the parts identified by reference number 37 are indicated.

Touch Up Paint

Exmark black touch up spray paint – gloss black.

Exmark red touch up paint (spray paint – P/N 1-850337 - .6 oz liquid bottle – P/N 103-9140).

Contents

Complete Deck Assembly	4
Deck Assembly	6
Deck W/Decals Assembly	8
Idler Arm Assembly No. 126-0976	10
Main Frame Assembly	12
Roll-Over Protection System Assembly	14
Deck Lift Assembly	16
Deck Strut Assembly	18
Control Panel Assembly	20
Motion Control Assembly	22
LH and RH Control Arm Assembly	24
Caster Tire Assembly	26
Caster Wheel Assembly	28
Rear Wheel Assembly	30
Seat Assembly	32
Seat Assembly (cont)	34
Fuel Assembly	36
Fuel Tank Assembly	38
Engine Assembly	40
Transaxle Assembly	42
LH Transaxle Assembly No. 135-0140	44
RH Transaxle Assembly No. 135-0139	46
Electrical Assembly	48
Harness Assembly No. 126-5803	50

Complete Deck Assembly

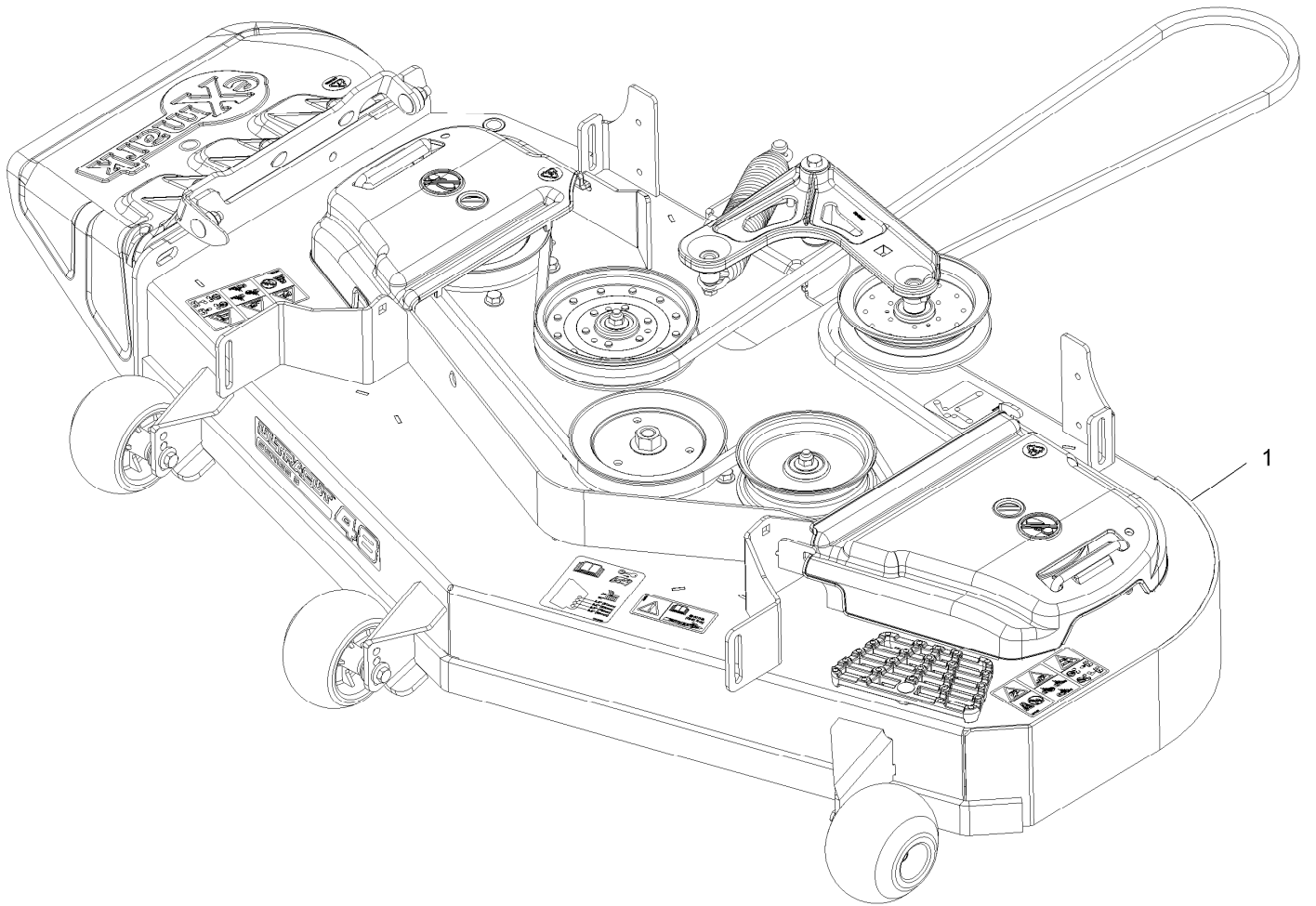

Complete Deck Assembly (continued)

<i>Ref.</i>	<i>Part Number</i>	<i>Qty.</i>	<i>Description</i>
1	126-8036	1	ASM-Deck Complete 483

Deck Assembly

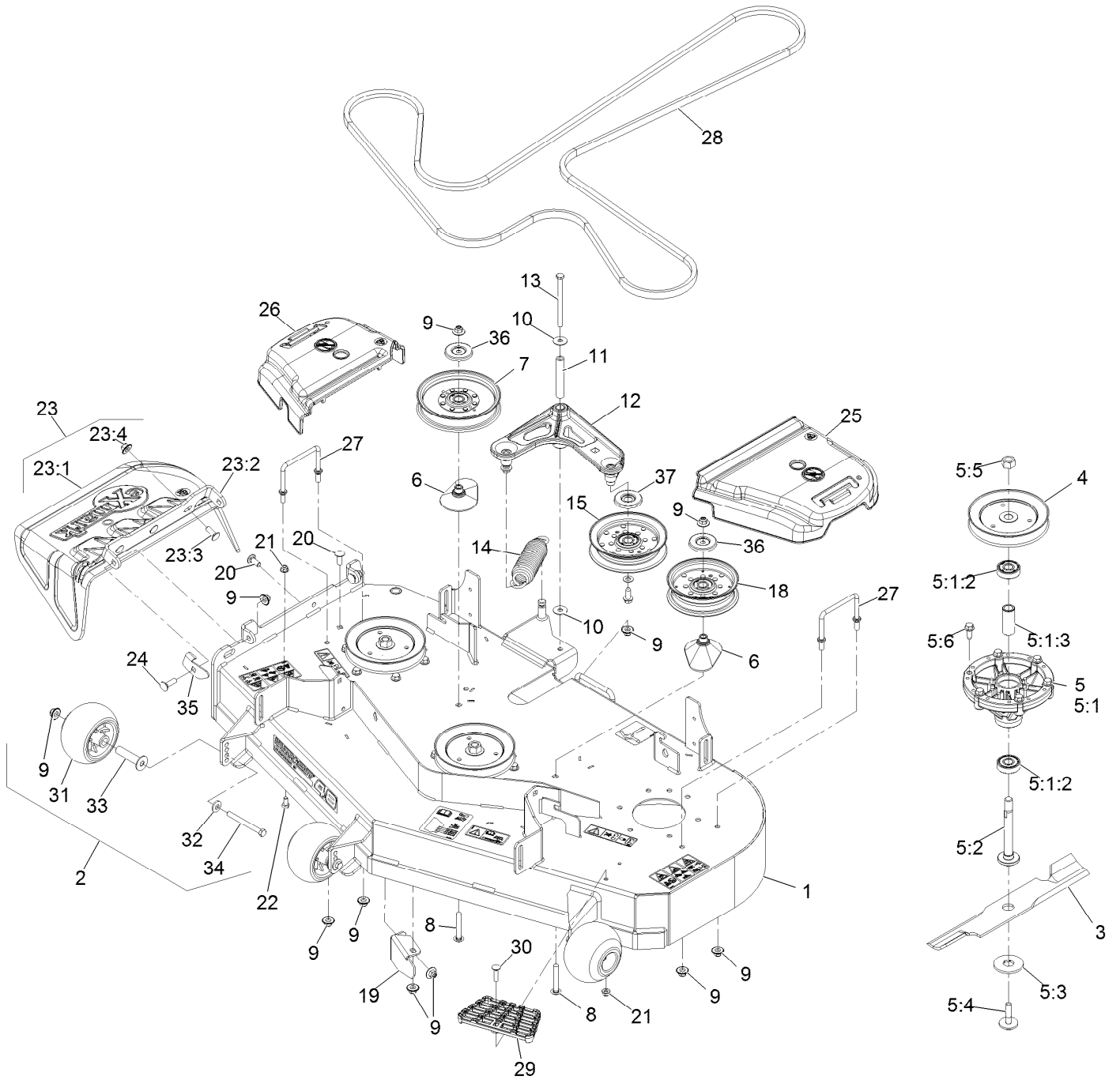

Deck Assembly (continued)

<i>Ref.</i>	<i>Part Number</i>	<i>Qty.</i>	<i>Description</i>	<i>Ref.</i>	<i>Part Number</i>	<i>Qty.</i>	<i>Description</i>
1	126-3575	1	ASM-Deck W/Decals 483	15	126-9196	1	Idler-Pulley, Flat
2	116-9981	3	Kit, Anti-Scalp Roller	18	126-9197	1	Idler-Pulley, Flat 5.00X1.31
3	103-6391	3	Blade, Mulching ◆	19	116-0680-01	1	Baffle, Discharge 483
3	103-6386	3	Blade, Low Lift ●	20	3231-22	2	Bolt-Carriage 3/8-16 X 1
3	103-6381	3	Blade, Solid ●	21	104-8300	2	Nut-Nyloc 5/16-18 Flg
3	103-6401	3	Blade-Notched	22	322-2	1	Screw-HH 5/16-18 X 5/8
3	116-5177	3	Blade-Extreme 2, 16.25" ●	23	109-7188	1	ASM, Discharge Chute
4	116-5043	3	Sheave, Blade Drive 5.90	23:1	109-2738	1	Chute, Discharge
5	126-4630	3	ASM, Cutter Housing Complete	23:2	109-8675-01	1	Bracket, Discharge Chute
5:1	126-4627	1	ASM-Cutter Housing	23:3	3231-22	3	Bolt-Carriage 3/8-16 X 1
5:1:2	116-4004	2	Bearing	23:4	109-6658	3	Nut-Nyloc 3/8-16 Flg
5:1:3	116-4876	1	Spacer-Bearing	24	3231-25	2	Bolt-Carriage 3/8-16 X 1 1/4
5:2	109-7431	1	Spindle-Hex Pilot □	25	109-6936	1	Cover-Belt, LH
5:3	126-4530	1	Washer-Hex Blade Drive	26	109-6935	1	Cover-Belt, RH
5:4	116-0005	1	Bolt-Blade, Sem ■ ○	27	109-6982	2	Wireform-Cover
5:5	3219-6	1	Nut-Hex 5/8-18 ▲	28	126-6626	1	Belt-V
5:6	126-1696	6	Screw-HWHTF	29	126-4781-03	1	Step-Deck
6	109-2872	2	Spacer-Pulley	30	3230-3	1	Bolt-Carriage 5/16-18 X 1 1/4
7	126-9189	1	Idler-Pulley, Flat 6.00X1.00	31	103-8415	3	Roller-Anti-Scalp
8	3231-44	2	Bolt-Carriage 3/8-16 X 2 1/2	32	98-5975	3	Washer-Spring Disc 3/8
9	109-6658	14	Nut-Nyloc 3/8-16 Flg	33	116-8131	3	Axle, Roller
10	52-2860	2	Washer	34	116-9362	3	Screw-HH 3/8-16 X 3 3/4 GR 8
11	116-5111	1	Bushing	35	135-0064	1	Stop-Discharge Chute
12	126-0976	1	Idler Arm ASM	36	126-8043	2	Shield-Dust
13	323-38	1	Screw-HH 3/8-16 X 4 3/4	37	126-9195	1	Shield-Guard, Dust
14	116-6317	1	Spring-Extension				

● Optional Equipment

▲ Torque to 75-85 ft-lb

◆ Requires installation of mulch kit for proper mulching. See your Exmark dealer for details.

□ Apply Mobil HTS grease (P/N 103-5217 1.5 oz packet) (or a food-grade anti-seize) to spindle shaft

○ Apply lubricant to threads as needed to prevent seizing. Copper based anti-seize preferable. Grease is an acceptable substitute.

■ Torque to 50-60 ft-lb

Deck W/Decals Assembly

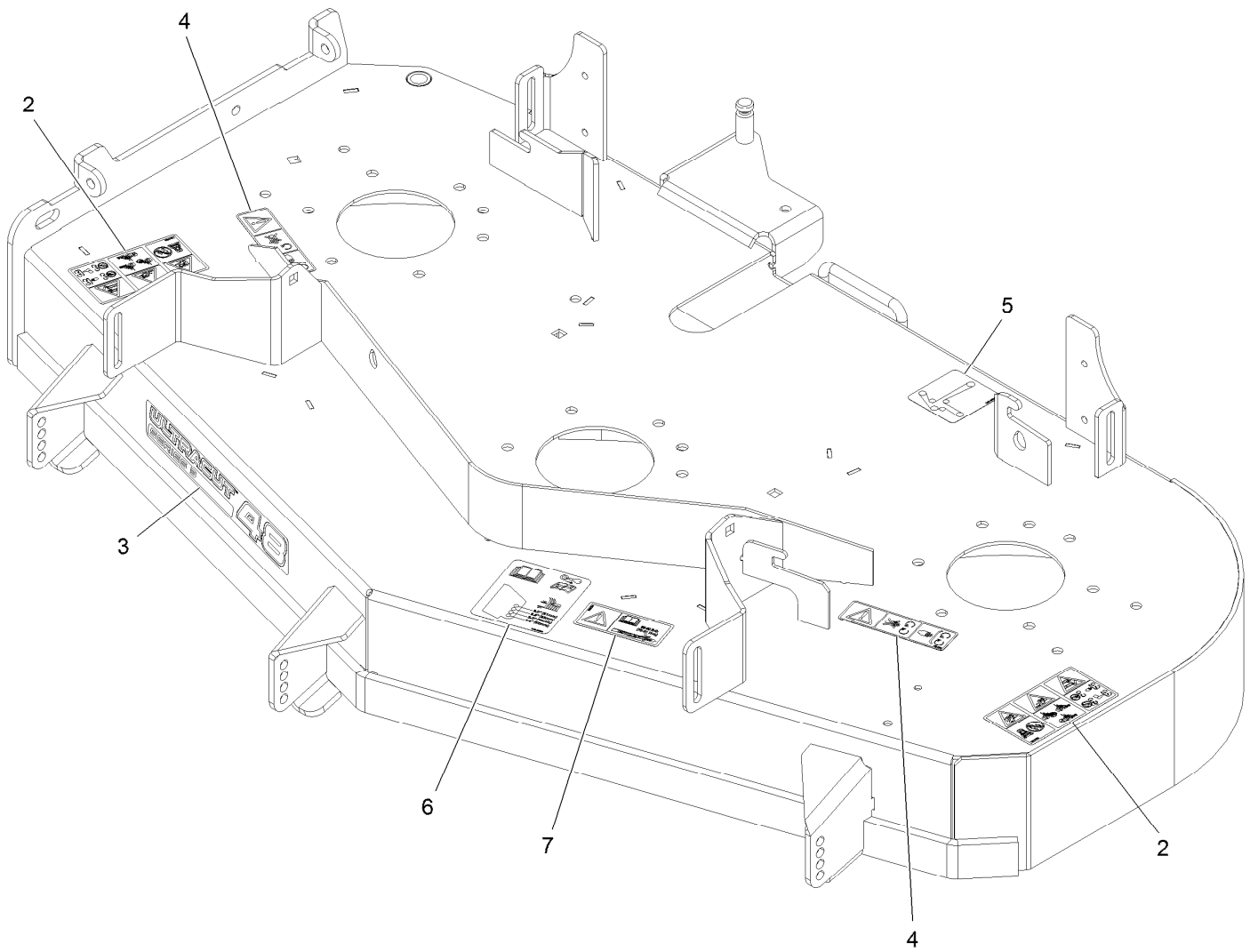

Deck W/Decals Assembly (continued)

<i>Ref.</i>	<i>Part Number</i>	<i>Qty.</i>	<i>Description</i>	<i>Ref.</i>	<i>Part Number</i>	<i>Qty.</i>	<i>Description</i>
2	126-6464	2	Decal-Danger Thrown Objects	5	109-6035	1	Decal-Routing, Belt
3	126-6746	1	Decal-Ultracut 48 Series 3	6	109-6036	1	Decal-Roller, Anti-Scalp
4	112-9028	2	Decal-Cover, Missing	7	116-8283	1	Decal-Torque, Bolt

Idler Arm Assembly No. 126-0976

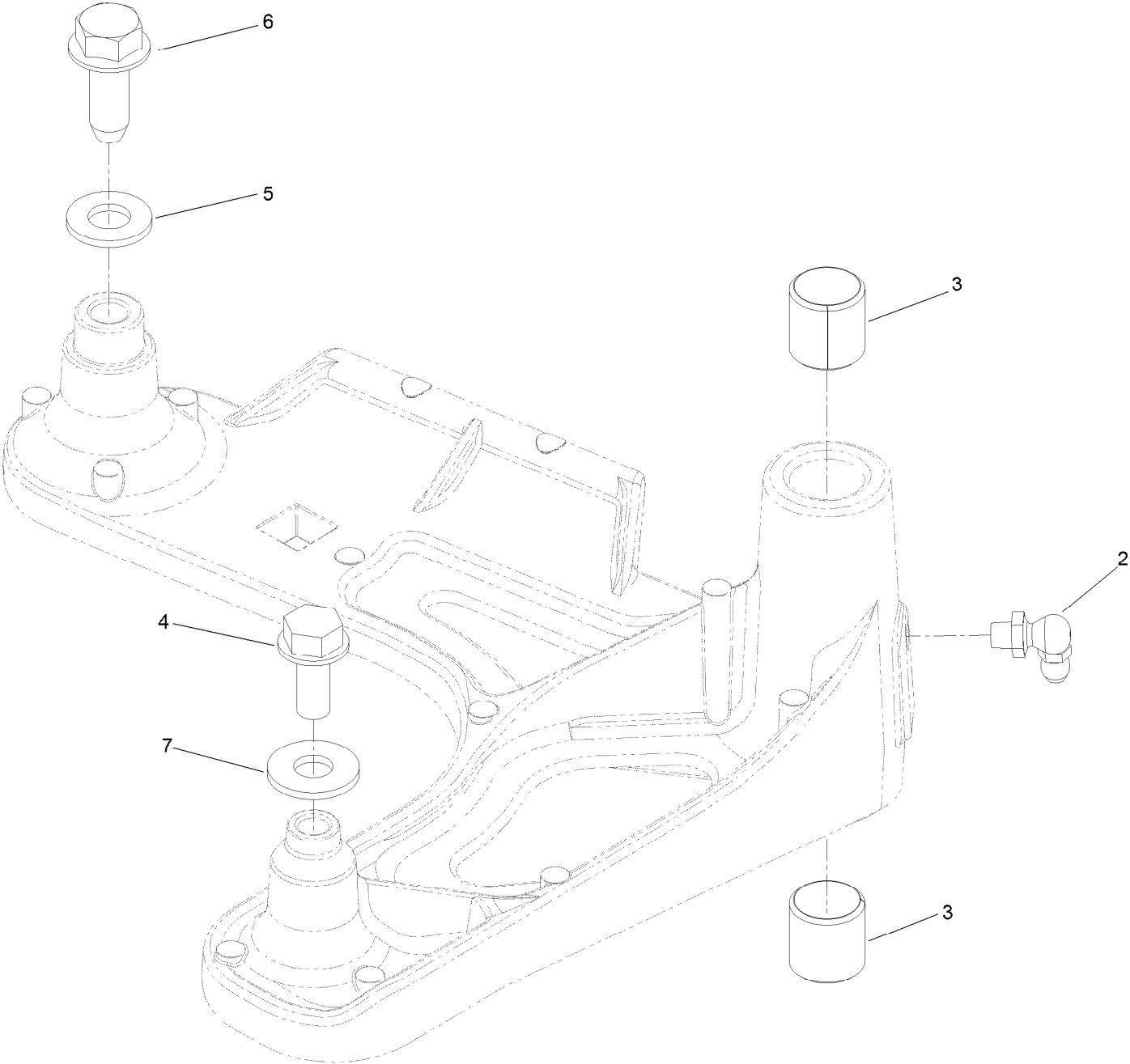

Idler Arm Assembly No. 126-0976 (continued)

<i>Ref.</i>	<i>Part Number</i>	<i>Qty.</i>	<i>Description</i>
2	302-40	1	Fitting-Grease, 90 DEG
3	1-513034	2	Sleeve-Bearing
4	32144-11	1	Screw-HWH

<i>Ref.</i>	<i>Part Number</i>	<i>Qty.</i>	<i>Description</i>
5	3256-24	1	Washer-Flat
6	126-1696	1	Screw-HWHTF
7	3256-3	1	Washer-Flat

Main Frame Assembly

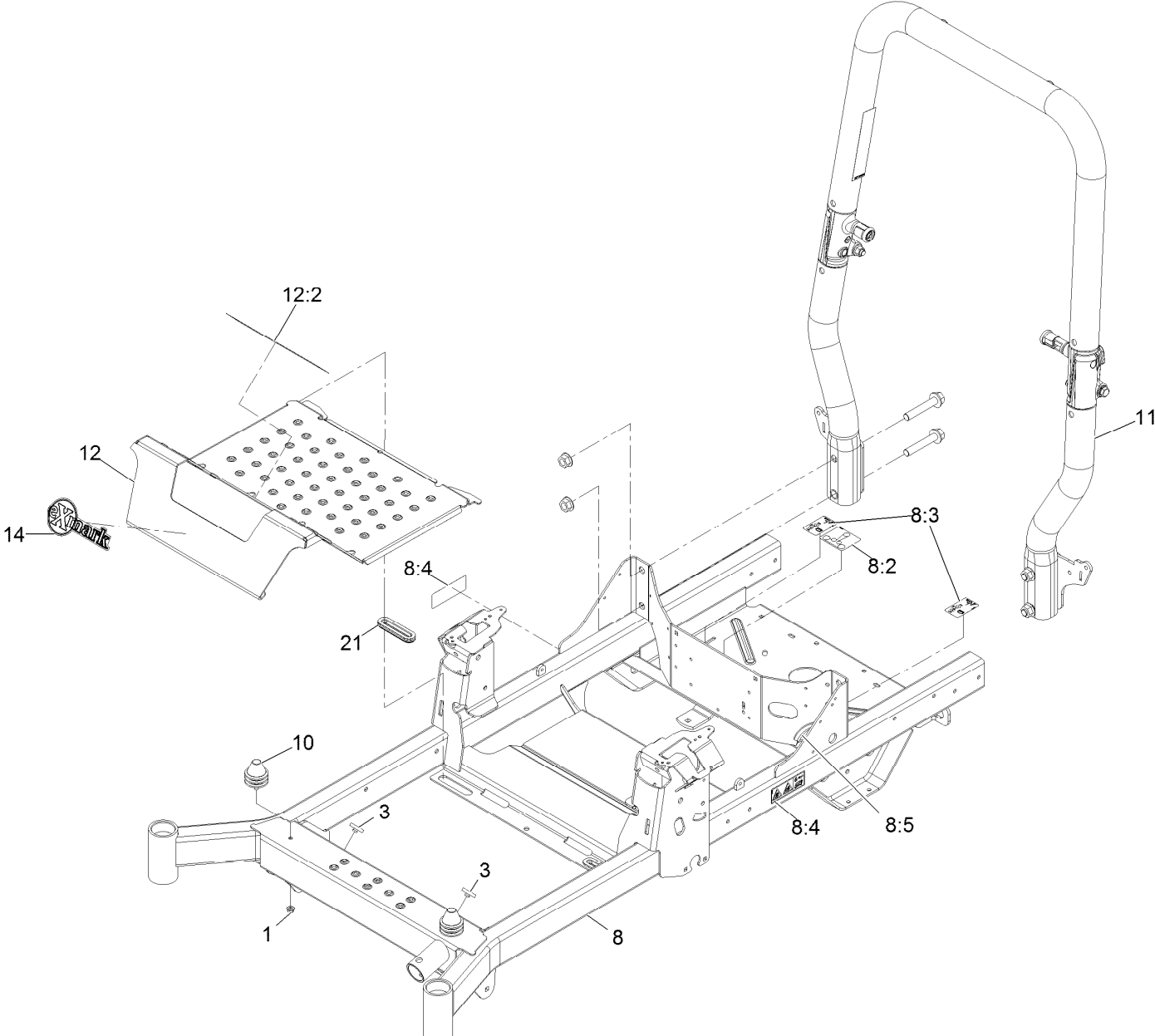

Main Frame Assembly (continued)

<i>Ref.</i>	<i>Part Number</i>	<i>Qty.</i>	<i>Description</i>	<i>Ref.</i>	<i>Part Number</i>	<i>Qty.</i>	<i>Description</i>
1	104-8300	2	Nut-Nyloc 5/16-18 Flg	10	126-5491	2	Isolator
3	109-9233	2	Bumper-Push-In, Rubber	11	126-9525	1	ASM-ROPS Tapered
8	126-4699	1	Frame ASM	12	126-5872	1	Pan-Floor
8:2	109-6014	1	Decal-Routing, Belt	12:2	126-8383	1	Decal-Danger
8:3	116-8588	2	Decal-Release, Drive	14	126-8819	1	Decal-Exmark Logo
8:4	126-4363	2	Decal-Warning	21	126-7065	2	Grommet-Rubber
8:5	127-6618	1	Strip-Seal				

Roll-Over Protection System Assembly

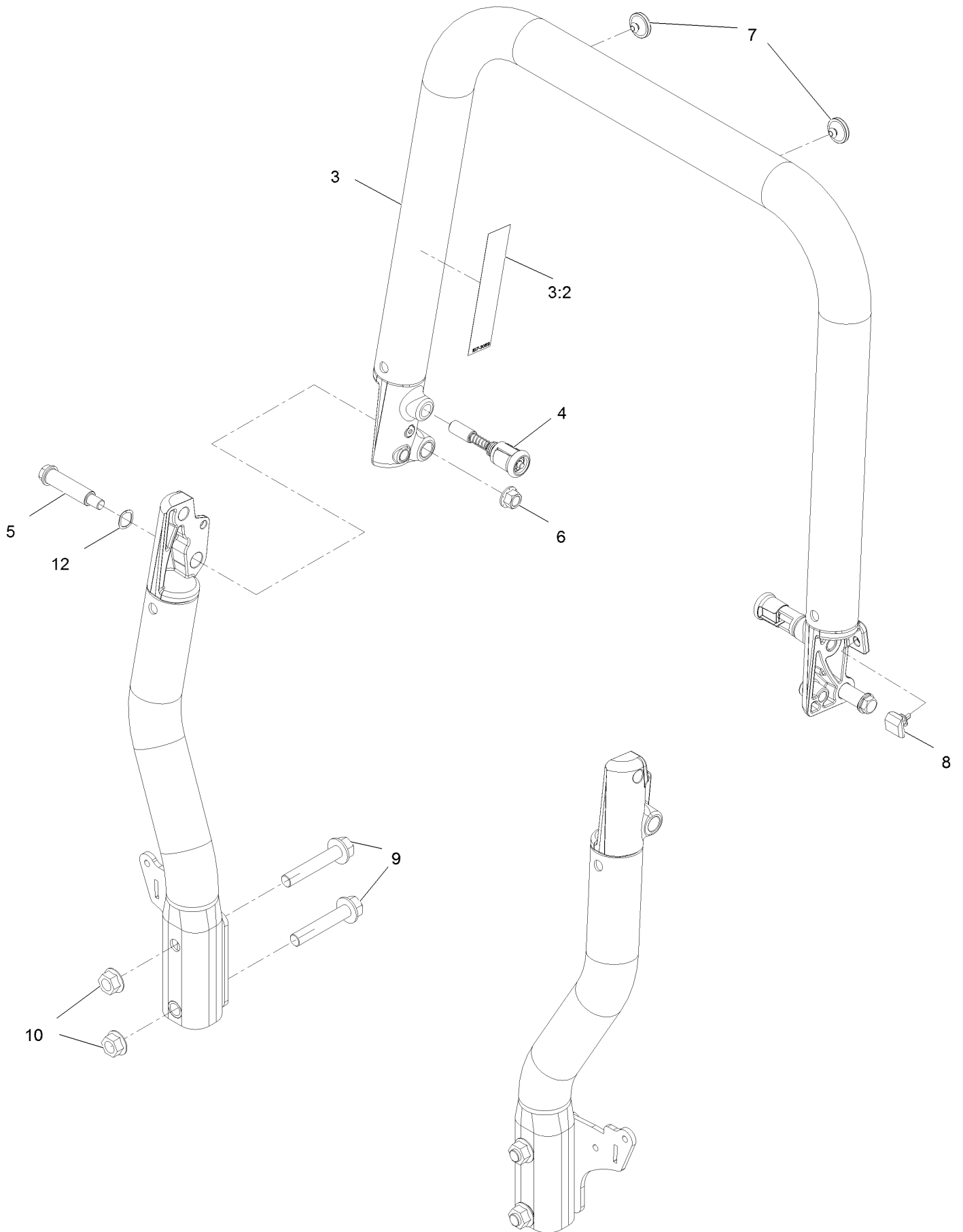

Roll-Over Protection System Assembly (continued)

<i>Ref.</i>	<i>Part Number</i>	<i>Qty.</i>	<i>Description</i>	<i>Ref.</i>	<i>Part Number</i>	<i>Qty.</i>	<i>Description</i>
3	126-7838	1	Top Tube ASM	7	135-0504	2	Bumper-ROPS
3:2	107-3069	1	Decal-Warning	8	126-9966	2	Bumper-ROPS
4	116-0104	2	Pin-Spring	9	126-9488	4	Screw-HHF
5	126-9209	2	Bolt-Shoulder	10	32128-50	4	Nut-Flange
6	99-5107	2	Nut-Lock	12	119-4164	2	Washer-Wave

Deck Lift Assembly

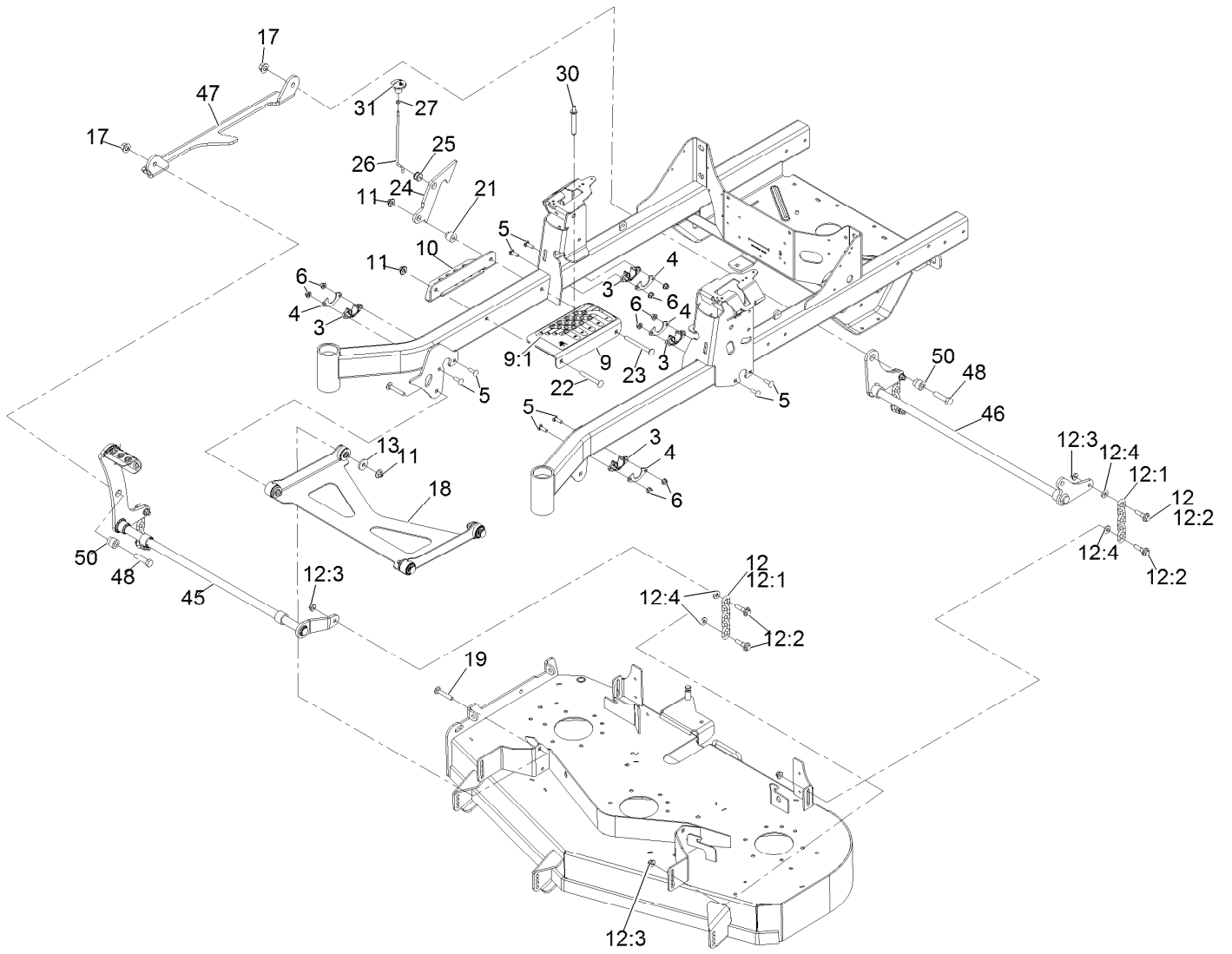

Deck Lift Assembly (continued)

<i>Ref.</i>	<i>Part Number</i>	<i>Qty.</i>	<i>Description</i>	<i>Ref.</i>	<i>Part Number</i>	<i>Qty.</i>	<i>Description</i>
3	115-5065	4	Bushing-Flange	18	126-8365	1	Deck Strut ASM
4	116-2887	4	Gusset-Lift, Deck	19	3231-7	2	Bolt-Carriage 3/8-16 X 2 1/4
5	3230-22	8	Bolt-Carriage 5/16-18 X 1 Sp	21	126-5221	1	Spacer-Stepped
6	104-8300	8	Nut-Nyloc 5/16-18 Flg	22	3231-42	1	Bolt-Carriage 3/8-16 X 3
9	126-4535	1	Bracket ASM	23	135-0313	1	Screw-CARR
9:1	126-4784	1	Decal-HOC	24	126-5222	1	Plate-Lock, Transport
10	126-4640-03	1	Angle-HOC, Lower	25	126-5593	1	Grommet
11	109-6658	4	Nut-Nyloc 3/8-16 Flg	26	126-5223	1	Rod-Lock, Transport
12	126-8877	4	Deck Chain ASM	27	3218-1	1	Nut-Jam 1/4-20
12:1	1-633447	1	Chain-Lift, Deck	30	126-5401	1	Pin-HOC
12:2	130-0742	2	Bolt-Shoulder	31	126-7019	1	Knob
12:3	104-8301	2	Nut-Nyloc 3/8-16 Flg	45	135-5083-03	1	Shaft-Decklift Front
12:4	43-0940	2	Spacer	46	135-5081-03	1	Shaft-Decklift Rear
13	1-373034	2	Washer	47	135-5079-03	1	Link-Decklift
17	99-5107	2	Nut-Lock 1/2-13	48	325-8	2	Screw-HH 1/2-13 X 1 1/4
				50	135-5617	2	Spacer-Stepped

Deck Strut Assembly

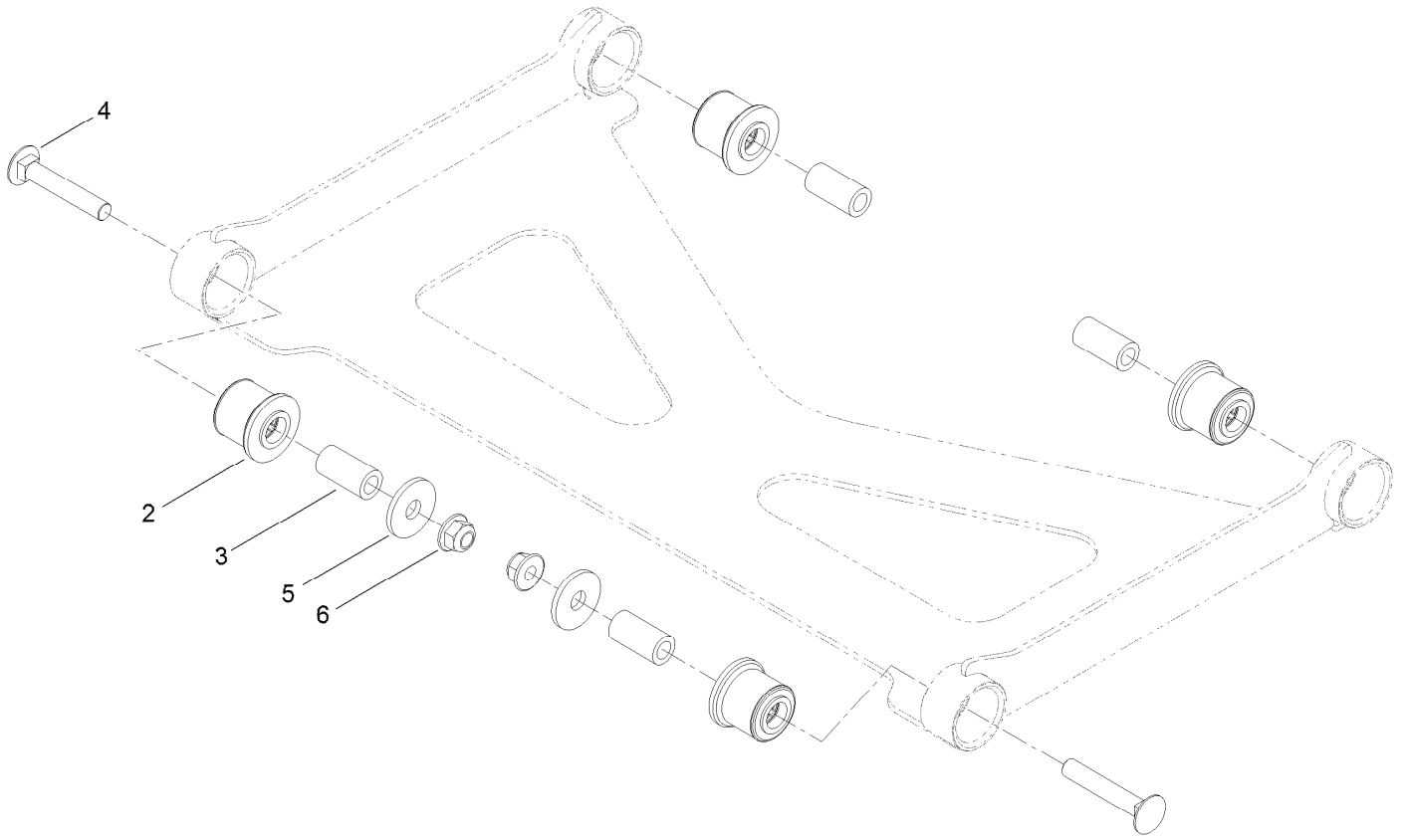

Deck Strut Assembly (continued)

<i>Ref.</i>	<i>Part Number</i>	<i>Qty.</i>	<i>Description</i>	<i>Ref.</i>	<i>Part Number</i>	<i>Qty.</i>	<i>Description</i>
2	126-8360	4	Bushing-Rubber, Suspension	4	3231-7	2	Bolt-Carriage 3/8-16 X 2 1/4
3	108-6544	4	Spacer	5	2844	2	Washer
				6	104-8301	2	Nut-Nyloc 3/8-16 Flg

Control Panel Assembly

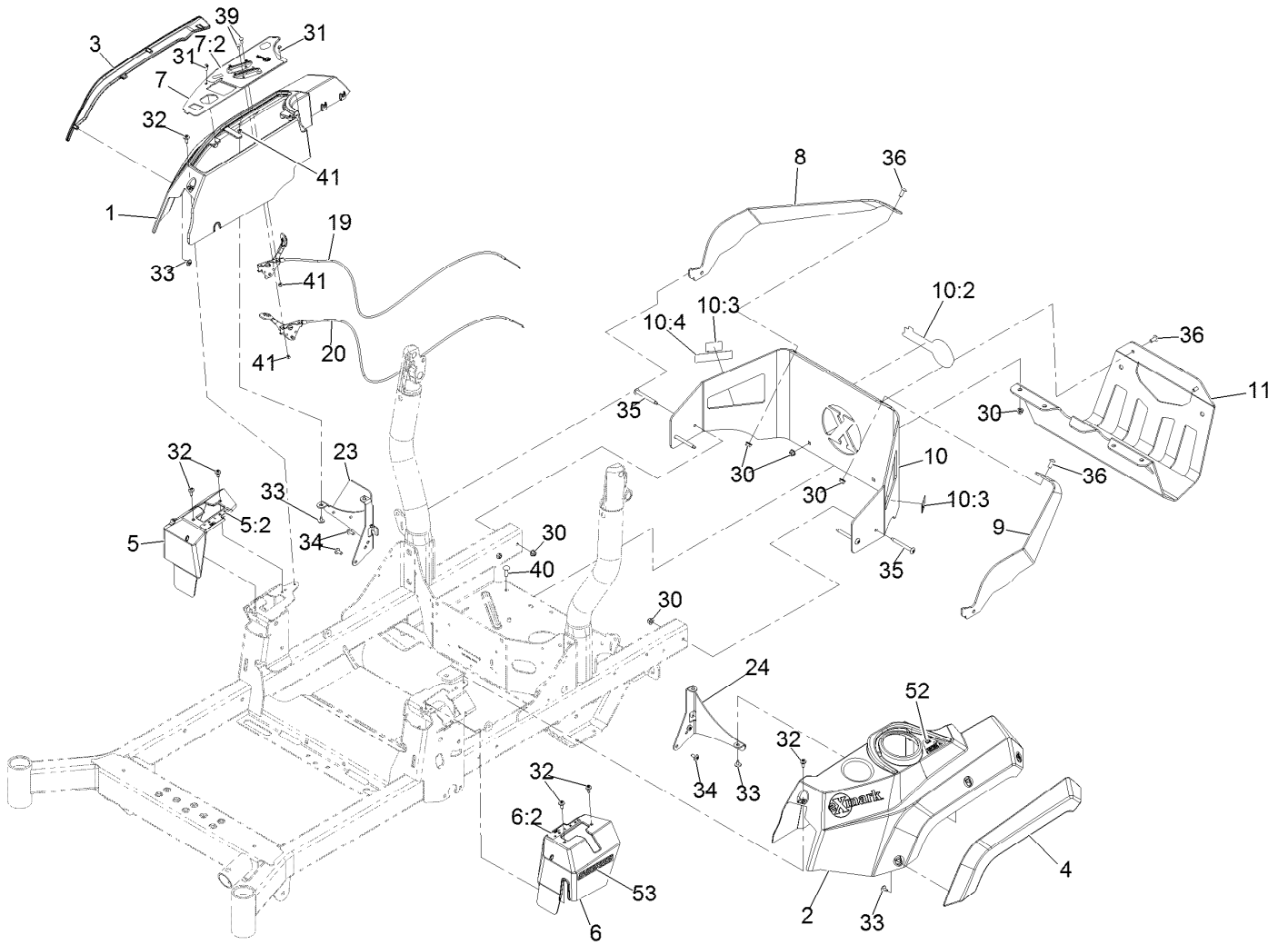

Control Panel Assembly (continued)

<i>Ref.</i>	<i>Part Number</i>	<i>Qty.</i>	<i>Description</i>	<i>Ref.</i>	<i>Part Number</i>	<i>Qty.</i>	<i>Description</i>
1	126-4959	1	Console-Exmark, RH	11	135-5084-03	1	Guard-Muffler [black]
2	126-4960	1	Console, LH	19	126-6945	1	Cable-Control, Choke
3	126-4741	1	Fender-RH	20	126-6944	1	Cable-Control, Throttle
4	126-4742	1	Fender-LH	23	126-9945	1	Support-Console, RH
5	126-7371	1	Cover-Control, Motion (RH)	24	126-5532-03	1	Bracket-Console, LH
5:2	126-6183	1	Decal-Control, Motion (RH)	30	104-8300	10	Nut-HF, NI
6	126-7372	1	Cover-Control, Motion (LH)	31	117-5036	2	Screw-Plastic, HWH
6:2	126-6194	1	Decal-Control, Motion (LH)	32	120-7950	6	Screw-Torx
7	135-7845	1	ASM-Control Panel W/Exmark Decal	33	126-5544	10	Screw-Torx
7:2	135-7816	1	Decal-Control Panel	34	126-6266	4	Screw-Tph
8	126-6015-03	1	Support-Upper, RH	35	126-6267	4	Screw-Torx
9	126-6016-03	1	Support-Upper, LH	36	126-6268	4	Screw-Torx
10	126-7802	1	Rear Guard ASM	39	1-807513	4	Bolt-CARR
10:2	126-6877	1	Decal, Exmark Logo	40	3230-22	2	Screw-CARR
10:3	106-5517	2	Decal-Warning	41	3296-2	4	Nut-Lock, NI
10:4	133-8062	1	Decal-Arrestor, Spark	52	126-9939	1	Decal-Fill, Fuel
				53	126-9296	2	Decal-S-Series

Motion Control Assembly

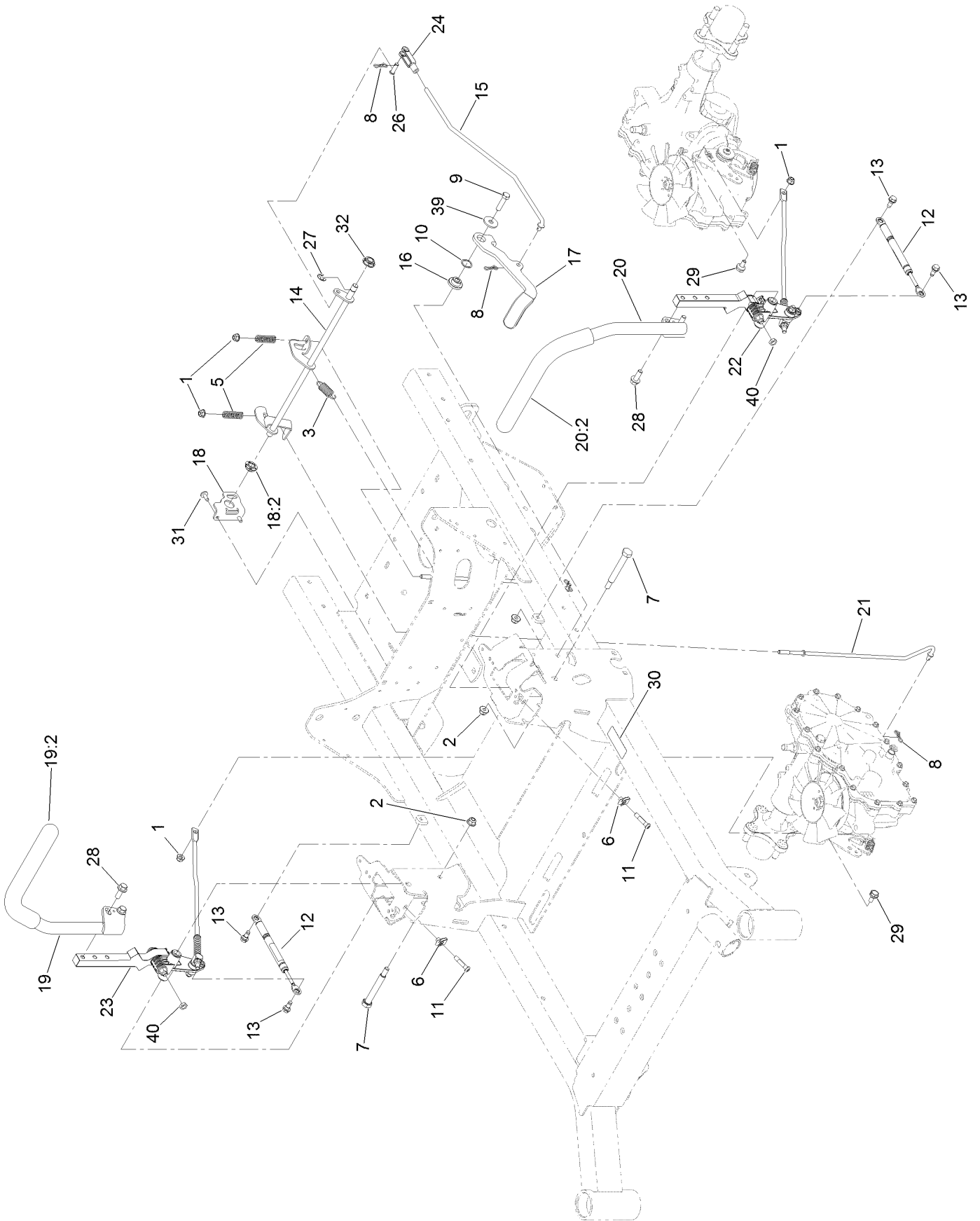

Motion Control Assembly (continued)

<i>Ref.</i>	<i>Part Number</i>	<i>Qty.</i>	<i>Description</i>	<i>Ref.</i>	<i>Part Number</i>	<i>Qty.</i>	<i>Description</i>
1	104-8300	4	Nut-HF, NI	19	126-9191	1	RH Control Handle ASM
2	104-8301	3	Nut-HF, NI	19:2	126-7359	1	Grip
3	107-1045	1	Spring-Extension	20	126-9192	1	LH Control Handle ASM
5	109-7694	2	Spring-Compression	20:2	126-7359	1	Grip
6	112-3306	2	Nut	21	126-7217	2	Linkage-Brake, Lower
7	115-5099	2	Bolt-Pivot	22		1	LH Motion Control ASM ●
8	119-1415	4	Pin-Cotter, Locking	23		1	RH Motion Control ASM ●
9	323-8	1	Screw-HH	24	1-303105	1	Yoke-Adjustable
10	119-4164	1	Washer-Wave	26	1-808280	1	Pin-Clevis
11	126-4299	2	Screw-HSBH	27	32120-47	1	Ring-Retaining, External
12	126-4322	2	Damper	28	3234-42	4	Screw-HHF
13	126-4424	4	Screw-Shoulder	29	37-8771	2	Bolt-Shoulder, HF
14	126-5813	1	Shaft-Brake	30	115-9625	1	Decal-Brake, Parking
15	126-5819	1	Linkage-Brake, Upper	31	126-6266	2	Screw-Tph
16	126-5989	1	Pivot-Flange	32	126-5820	1	Bearing-Spherical
17	126-9490	1	Lever-Brake (With Grip)	39	2844	1	Washer
18	126-6456	1	Bracket-Brake	40	3218-3	2	Nut-Jam
18:2	126-5820	1	Bearing-Spherical				

● Not serviced separately

LH and RH Control Arm Assembly

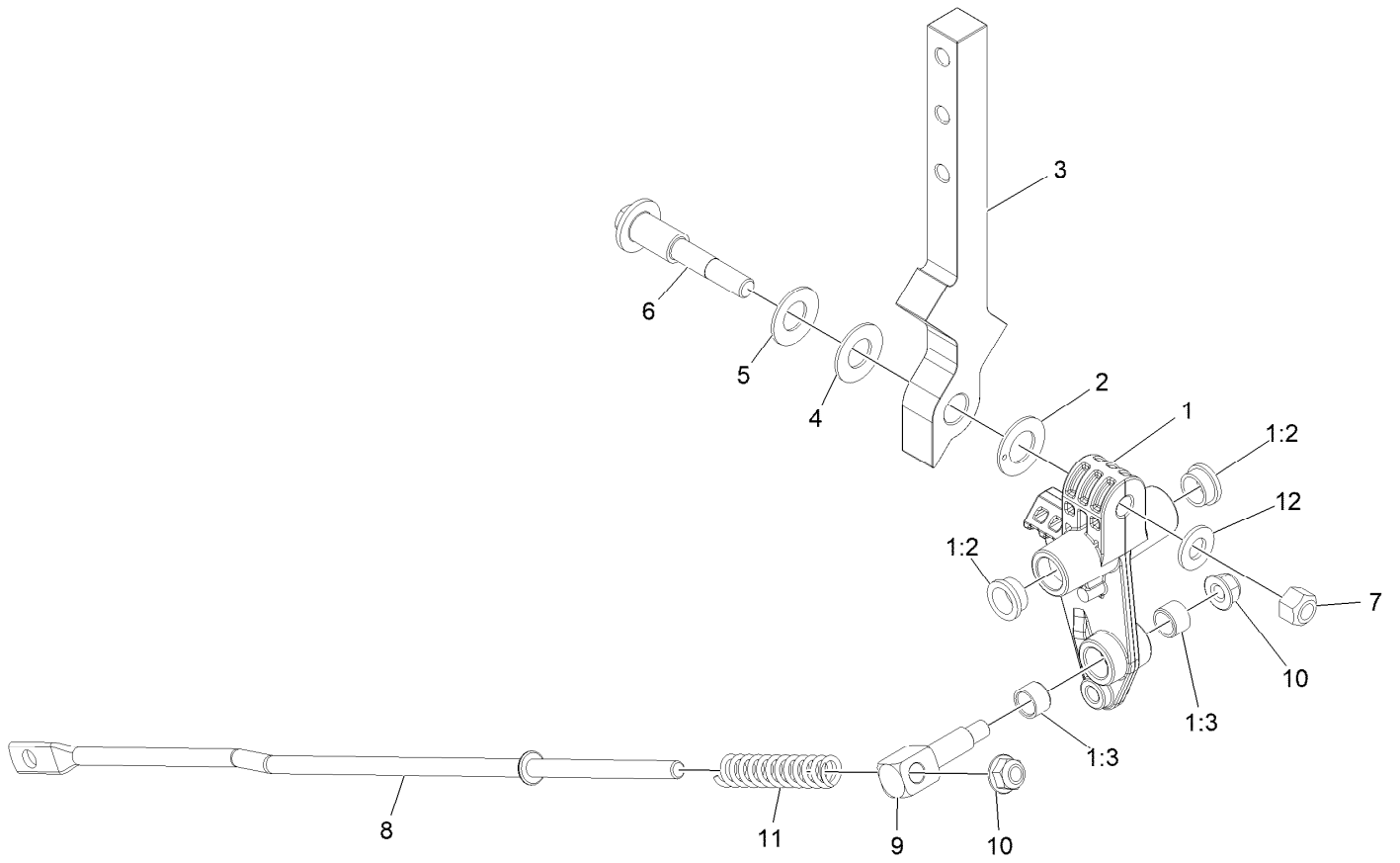

LH and RH Control Arm Assembly (continued)

<i>Ref.</i>	<i>Part Number</i>	<i>Qty.</i>	<i>Description</i>	<i>Ref.</i>	<i>Part Number</i>	<i>Qty.</i>	<i>Description</i>
1	126-3773	1	Control Arm ASM	6	117-1198	1	Bolt-Pivot
1:2	126-8909	2	Bushing	7	32152-2	1	Nut-Hex 3/8-16 Lock
1:3	1-413152	2	Bushing-Sleeve	8	126-5435	1	Link-Control
2	126-7296	1	Washer-Friction	9	126-5434	1	Swivel
3	126-8182	1	Arm-Control	10	104-8300	2	Nut-Nyloc 5/16-18 Flg
4	117-1240	1	Washer	11	126-8195	1	Spring-Return, Neutral
5	119-8925	1	Washer-Belleville	12	3256-24	1	Washer-3/8 SAE

Caster Tire Assembly

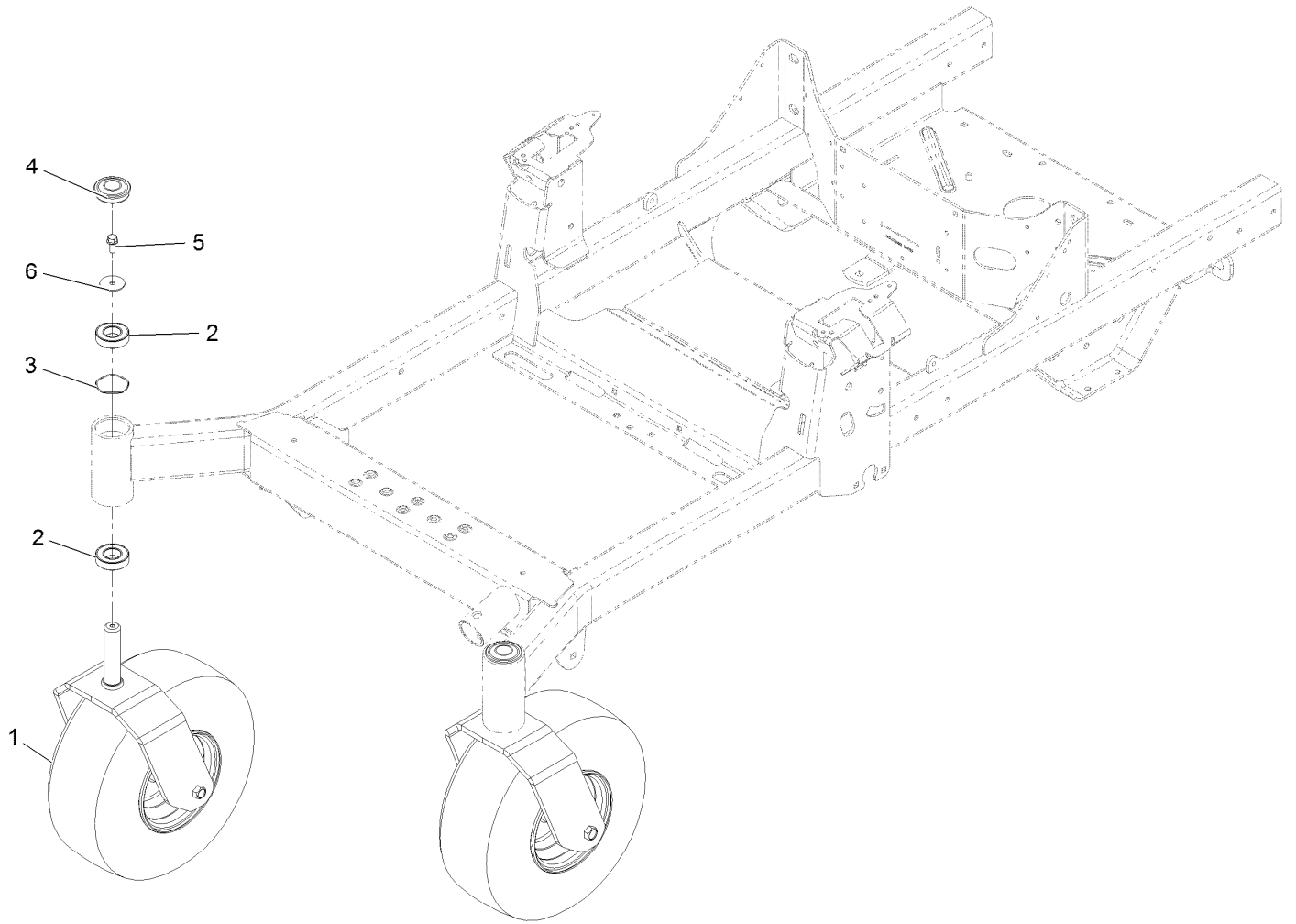

Caster Tire Assembly (continued)

<i>Ref.</i>	<i>Part Number</i>	<i>Qty.</i>	<i>Description</i>	<i>Ref.</i>	<i>Part Number</i>	<i>Qty.</i>	<i>Description</i>
1		2	ASM-Front Caster W/Fork ●	4	116-4348	2	Cap-Grease
2	109-3678	4	Bearing-Ball	5	3234-5	2	Screw-HHF
3	126-5897	2	Spring	6	3256-68	2	Washer-Flat

● Not serviced separately

Caster Wheel Assembly

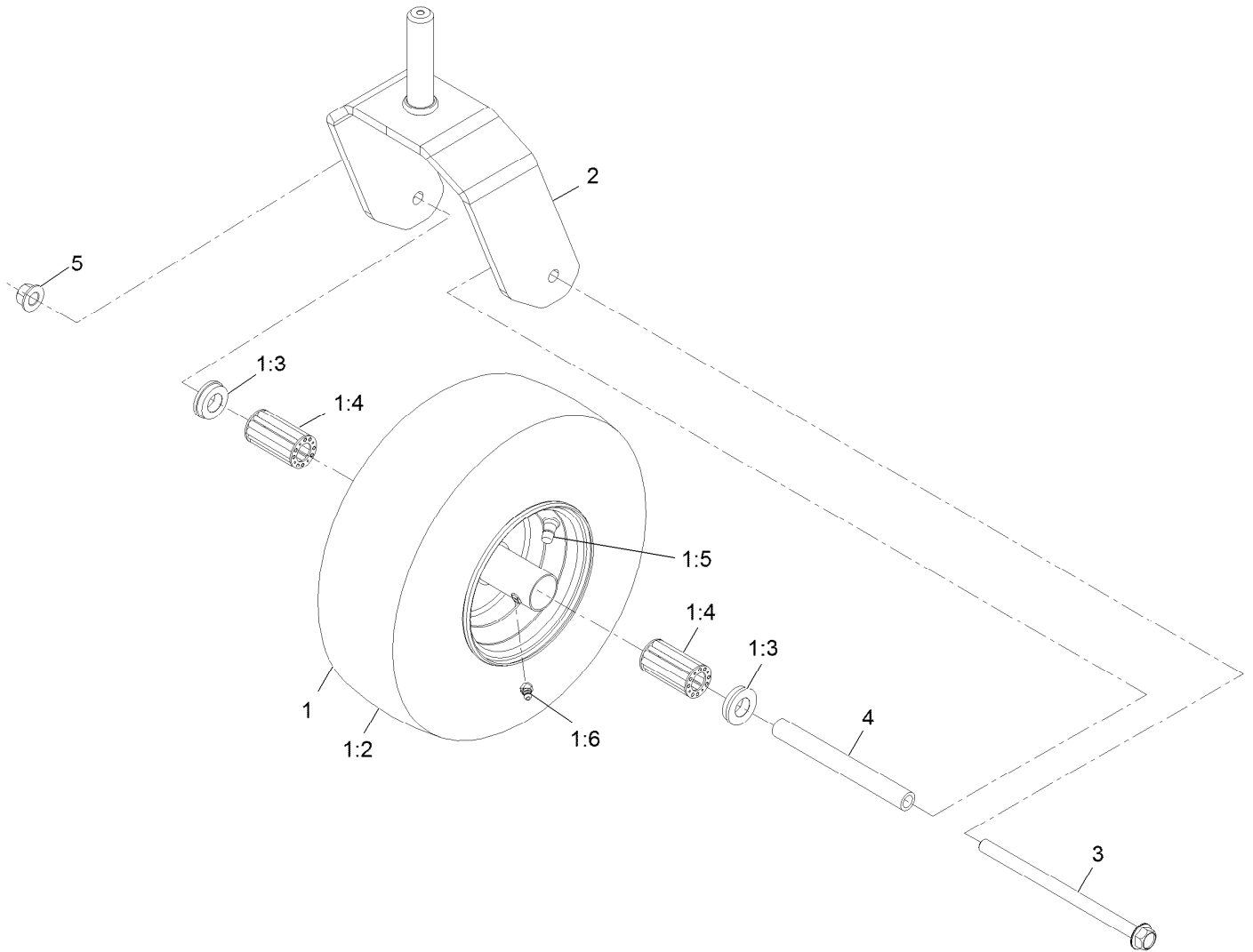

Caster Wheel Assembly (continued)

<i>Ref.</i>	<i>Part Number</i>	<i>Qty.</i>	<i>Description</i>	<i>Ref.</i>	<i>Part Number</i>	<i>Qty.</i>	<i>Description</i>
1	126-3289	1	ASM-Wheel And Tire 13X6.50-6	1:6	120-7125	1	Fitting-Zerk
1:2	126-5959	1	Tire	2	126-4312-01	1	Fork-Caster
1:3	130-0705	2	Bushing-Flange	3	126-5389	1	Screw-HHF
1:4	135-4489	2	Bearing-Roller, Wheel	4	127-0068	1	Spanner-Wheel, Caster
1:5	5108	1	Valve	5	99-5107	1	Nut-Lock 1/2-13

Rear Wheel Assembly

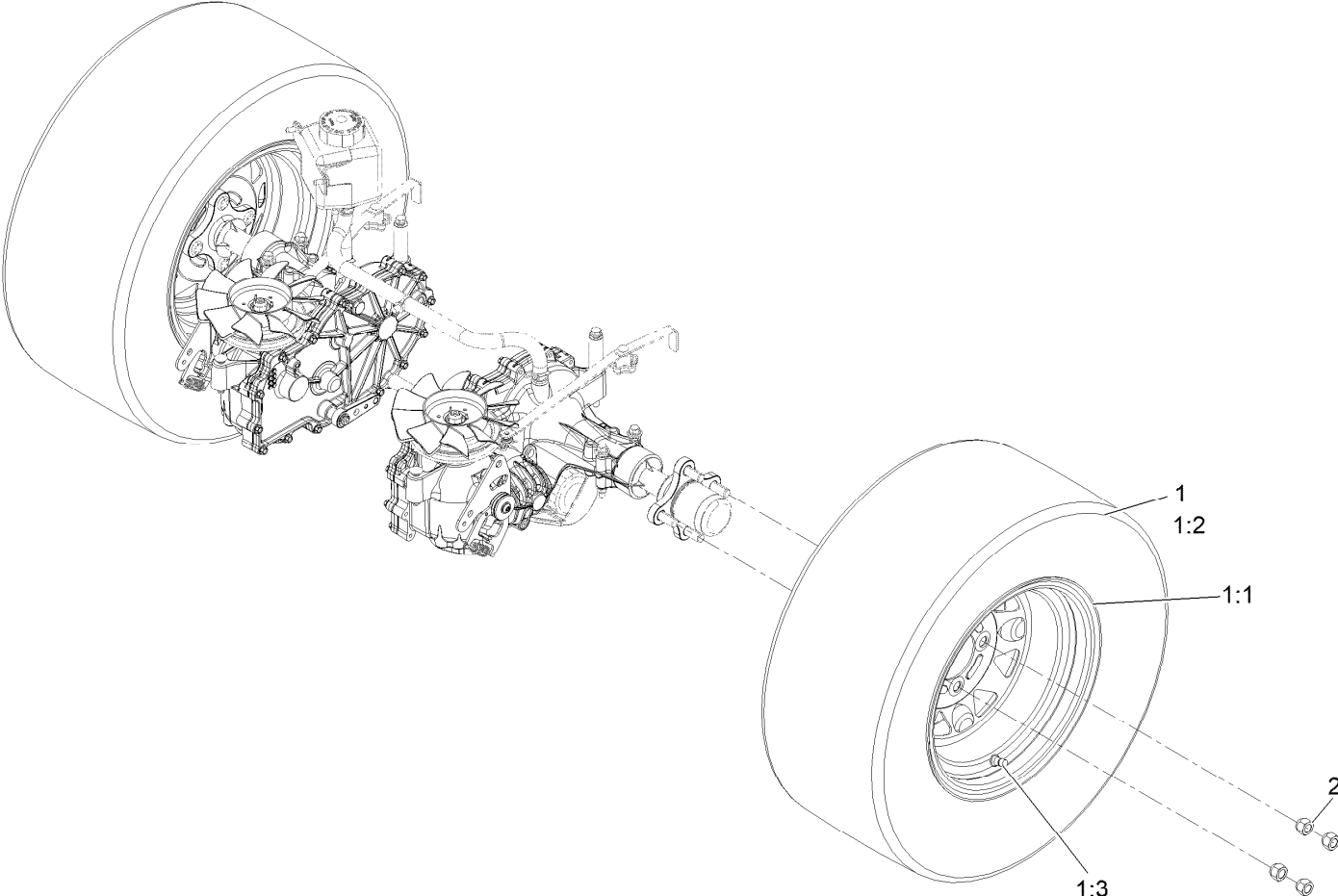

Rear Wheel Assembly (continued)

<i>Ref.</i>	<i>Part Number</i>	<i>Qty.</i>	<i>Description</i>
1	142-4264	2	Wheel And Tire ASM
1:1	142-4257	1	Wheel
1:2	142-4284	1	Tire

<i>Ref.</i>	<i>Part Number</i>	<i>Qty.</i>	<i>Description</i>
1:3	5108	1	Valve
2	242-50	8	Nut-Lug 1/2-20

Seat Assembly

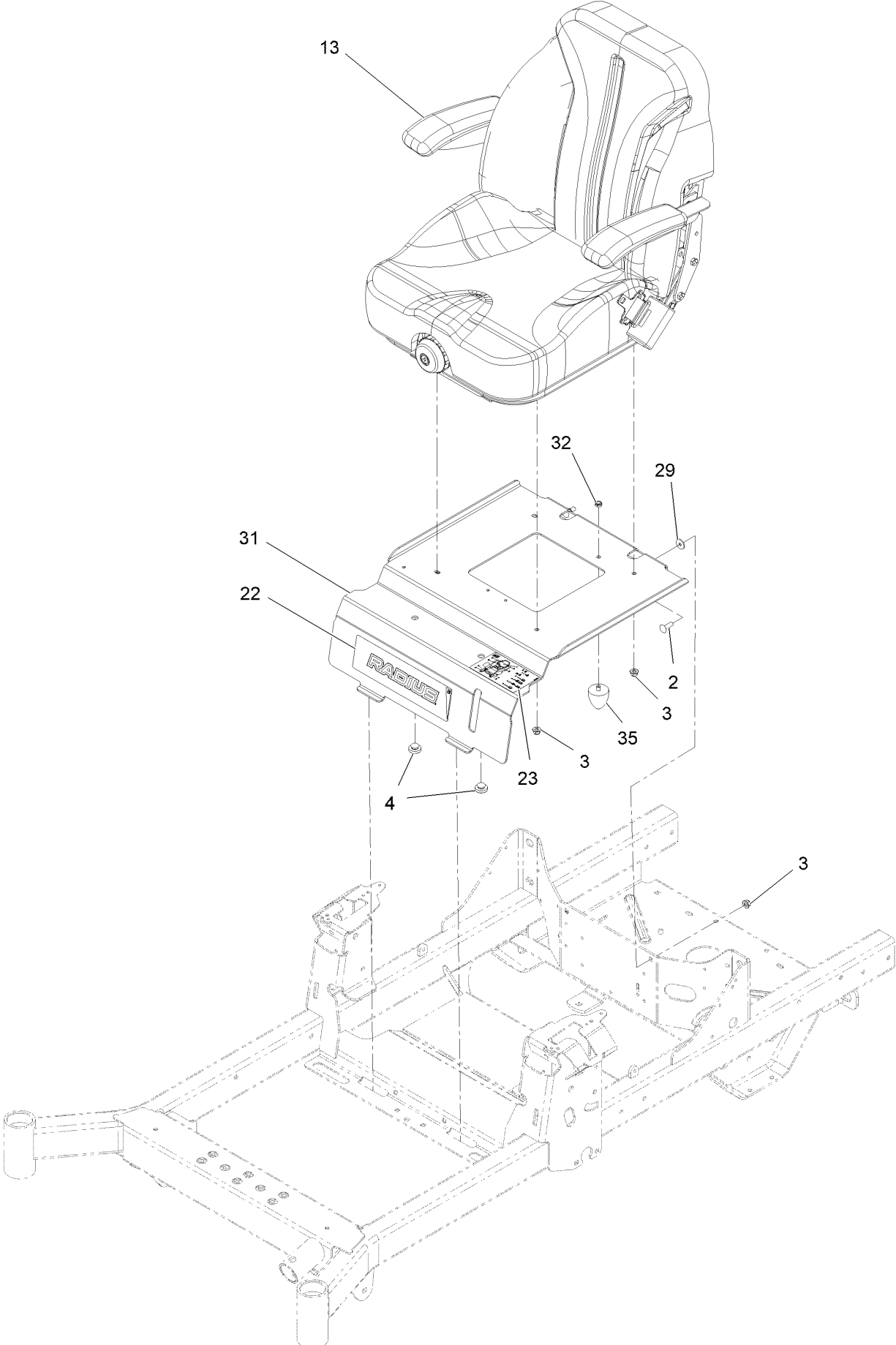

Seat Assembly (continued)

<i>Ref.</i>	<i>Part Number</i>	<i>Qty.</i>	<i>Description</i>	<i>Ref.</i>	<i>Part Number</i>	<i>Qty.</i>	<i>Description</i>
2	3230-22	4	Bolt-Carriage 5/16-18 X 1 Sp	23	126-8151	1	Decal-Aid, Service
3	104-8300	6	Nut-Nyloc 5/16-18 Flg	29	3256-67	2	Washer
4	135-0505	2	Bumper-Seat	31	135-6017-03	1	Plate-Fixed Seat [black]
13	126-8292	1	ASM-Susp Seat	32	3296-47	1	Nut-Nyloc 5/16-18 Thin
22	126-9082	1	Decal-Radius Logo	35	135-7047	1	Bumper-Rubber

Seat Assembly (cont)

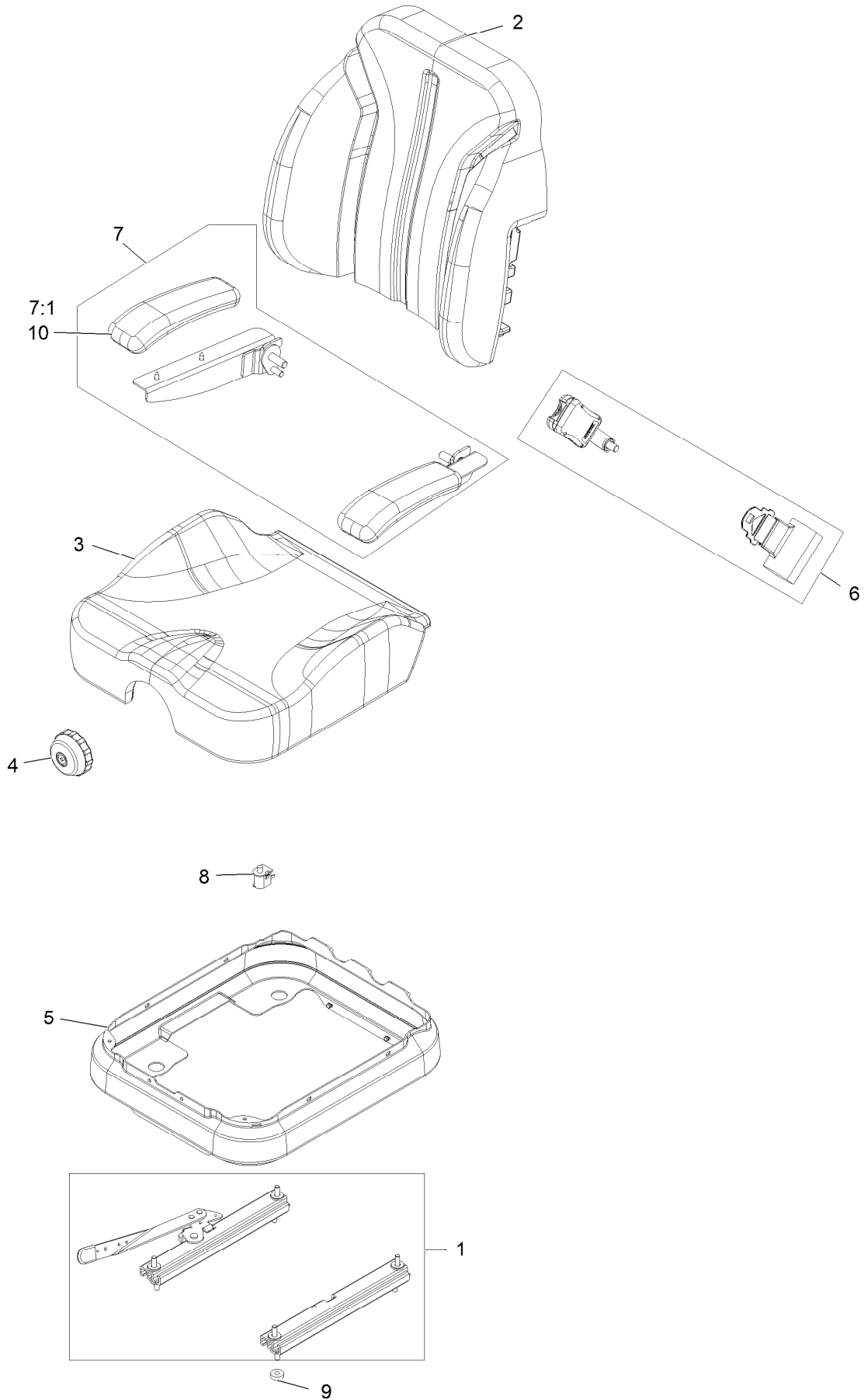

Seat Assembly (cont) (continued)

<i>Ref.</i>	<i>Part Number</i>	<i>Qty.</i>	<i>Description</i>	<i>Ref.</i>	<i>Part Number</i>	<i>Qty.</i>	<i>Description</i>
1	126-8558	1	Tracks-4" Travel	7	126-2058	1	Armrest Kit
2	126-8552	1	Cover-Seat Back Svc	7:1	110-4163	2	Cushion-Rest, Arm
3	126-8551	1	Cover-Seat Bottom Svc	8	82-2190	1	Switch
4	116-8911	1	Knob-Adjuster	9	26-4840	4	Spacer-Pin, Mounting
5	126-8559	1	Bellows-Seat	10	110-4163	2	Cushion-Rest, Arm
6	126-8560	1	Kit-Seat Belt				

Fuel Assembly

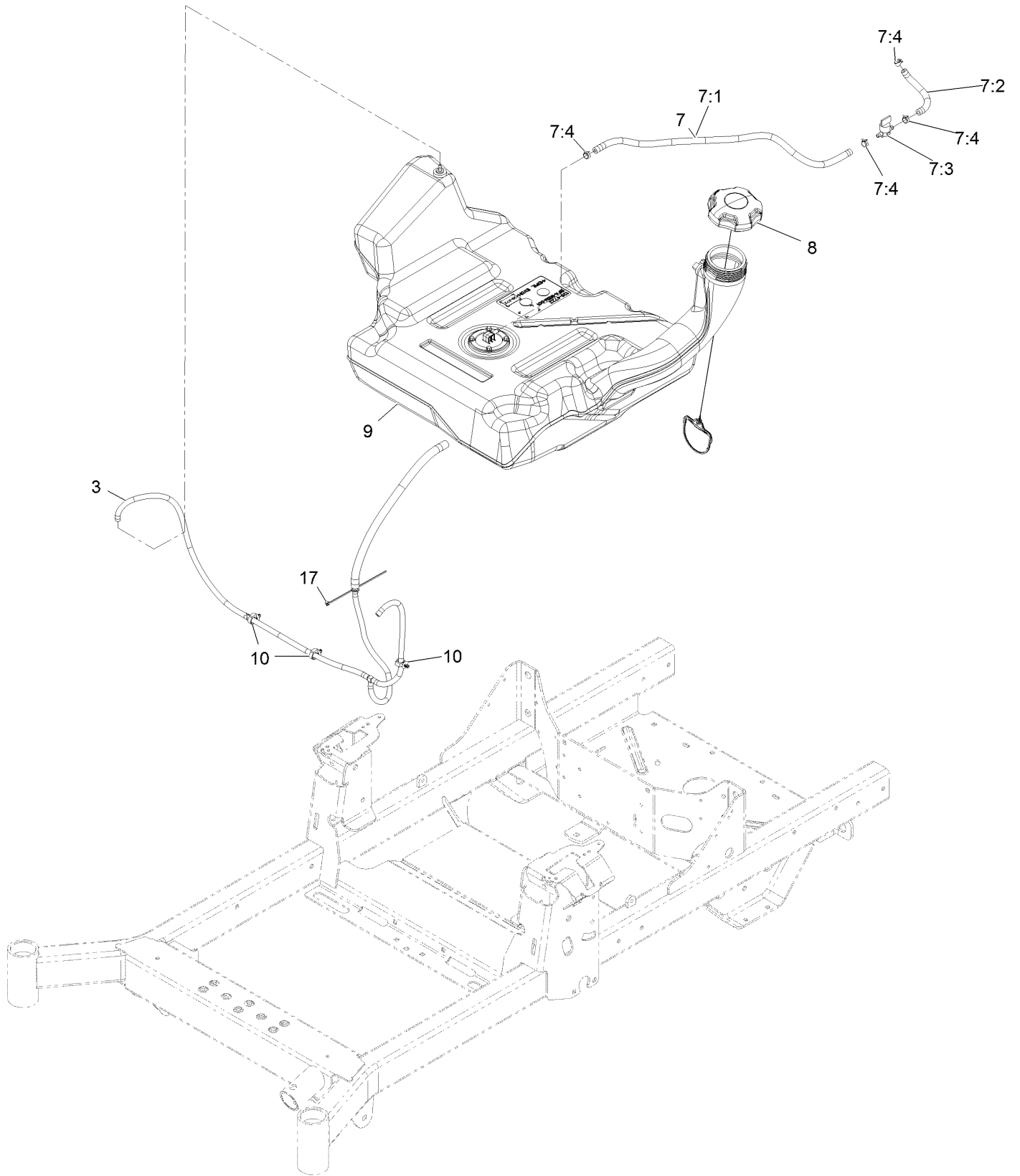

Fuel Assembly (continued)

<i>Ref.</i>	<i>Part Number</i>	<i>Qty.</i>	<i>Description</i>	<i>Ref.</i>	<i>Part Number</i>	<i>Qty.</i>	<i>Description</i>
3	126-8736	1	Vent Hose ASM	7:4	2412-98	4	Clamp-Hose
7	126-8740	1	Fuel Hose ASM	8	135-4801	1	Cap-Fuel, Ratcheting
7:1	109-0302	1	Hose-Fuel Line 24"	9	126-4724	1	Tank-Fuel
7:2	109-0678	1	Hose-Fuel	10	126-5523	3	Clip
7:3	1-603770	1	Valve-Fuel	17	1-303287	1	Tie-Cable 5 1/2 (Small)

Fuel Tank Assembly

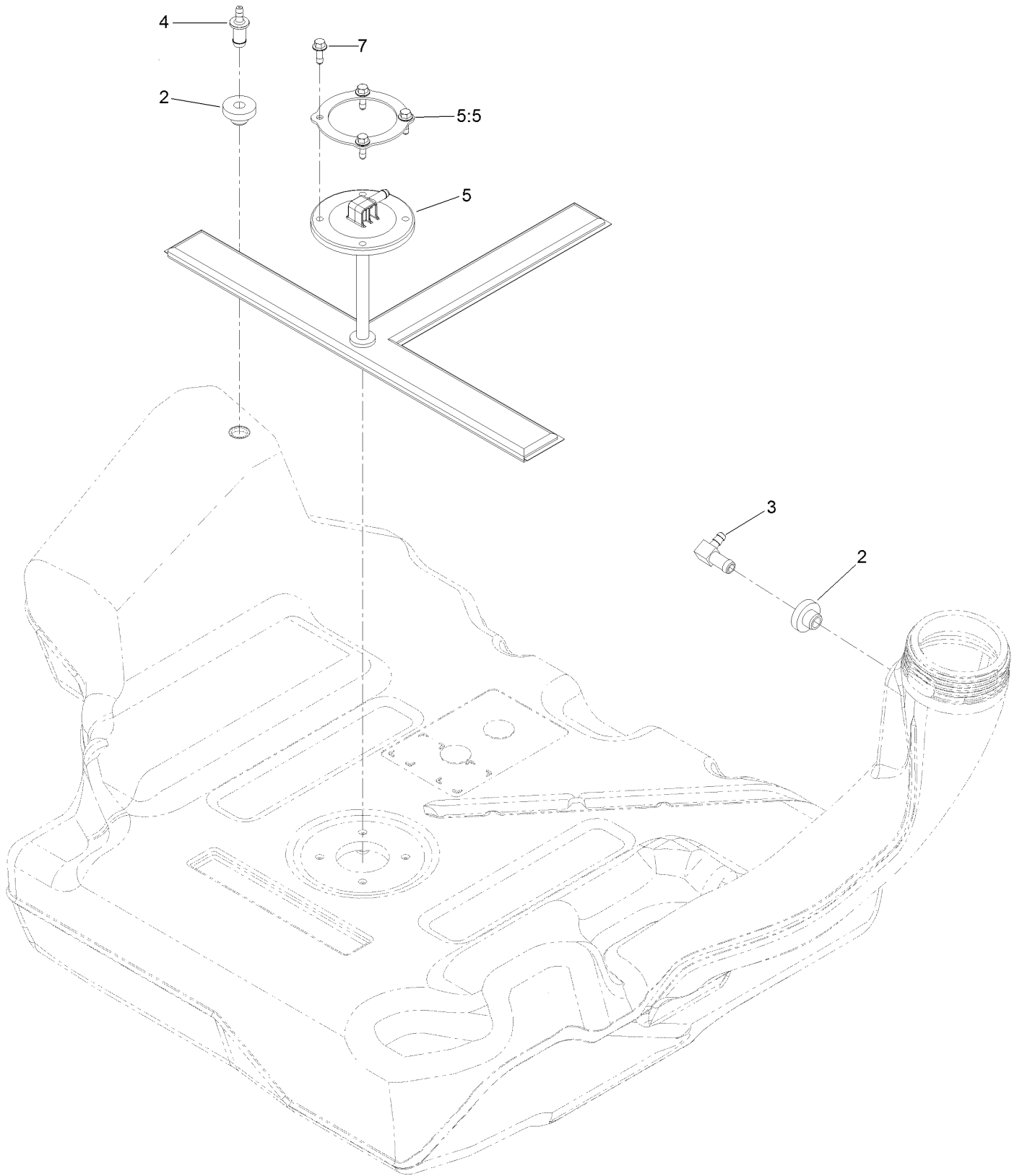

Fuel Tank Assembly (continued)

<i>Ref.</i>	<i>Part Number</i>	<i>Qty.</i>	<i>Description</i>	<i>Ref.</i>	<i>Part Number</i>	<i>Qty.</i>	<i>Description</i>
2	46-6560	2	Bushing	5	126-5528	1	Pickup-Fuel
3	126-9057	1	Fitting-90 DEG	5:5	126-5527	1	Ring-Retainer
4	116-4630	1	Fitting-Orifice, Straight	7	126-5525	4	Bolt

Engine Assembly

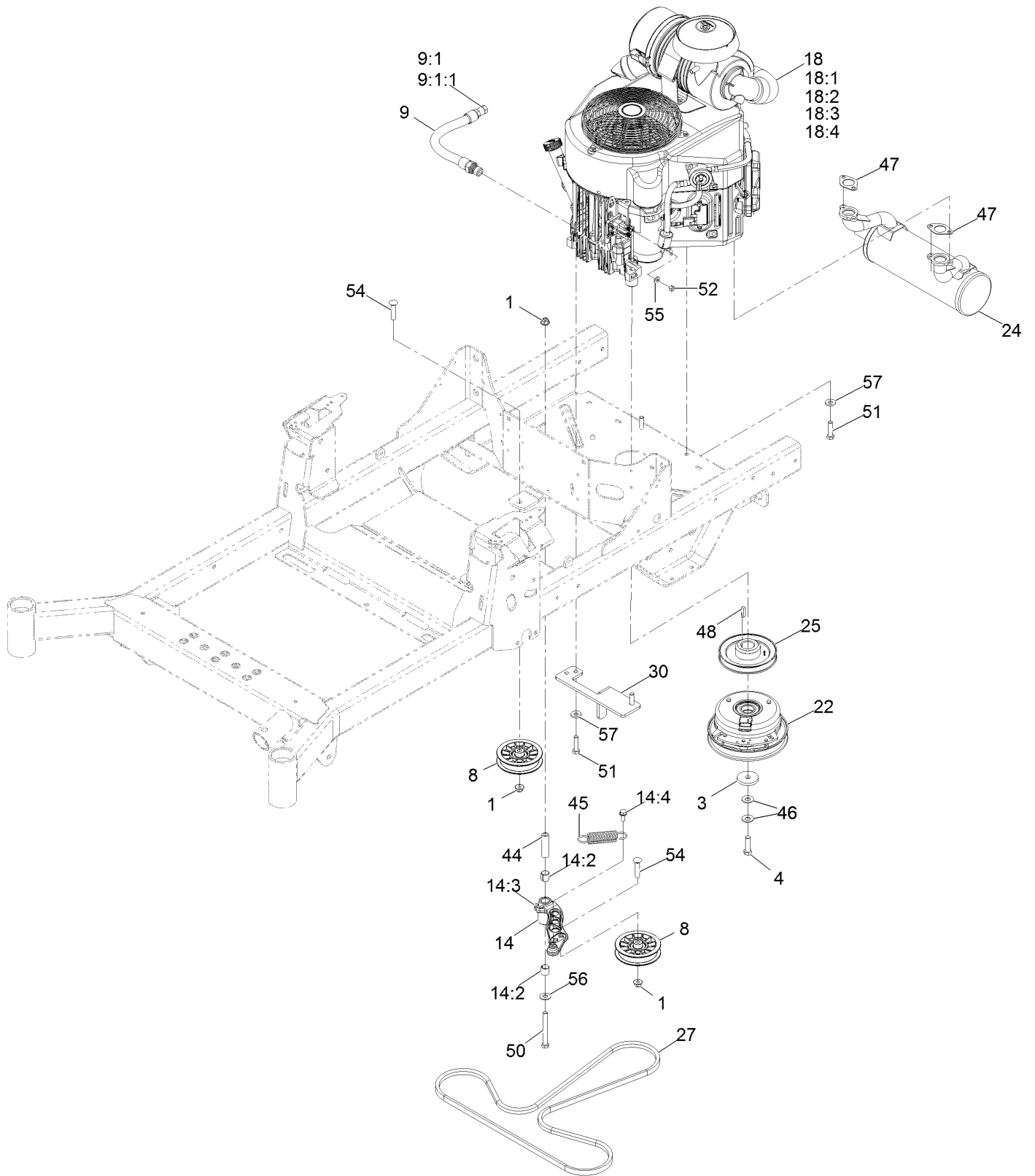

Engine Assembly (continued)

<i>Ref.</i>	<i>Part Number</i>	<i>Qty.</i>	<i>Description</i>	<i>Ref.</i>	<i>Part Number</i>	<i>Qty.</i>	<i>Description</i>
1	104-8301	3	Nut-Nyloc 3/8-16 Flg	18:4		1	Kawasaki 11013-7044
3	109-6919	1	Washer-Clutch				Engine Air Filter ▲◆
4	109-9761	1	Screw-HH 7/16-20 X 1 1/2 W/Loctite □	22	126-4324	1	Clutch
8	116-2456	2	Pulley-Flat Idler	24	126-4360	1	Muffler
9	116-4924	1	Asm-Hose Oil Drain W/Plug ■	25	126-5358	1	Sheave (W/Hub)
9:1	353-508	1	Plug-W/O-Ring ●	27	126-5993	1	Belt-V
9:1:1	237-42	1	O-Ring	30	126-6687-03	1	Anchor-Clutch
14	126-0973	1	Idler Arm ASM	44	1-603384	1	Bushing-Pivot, Idler
14:2	1-513034	2	Sleeve-Bearing	45	1-603402	1	Spring-Extension
14:3	302-40	1	Zerk-90° 1/4-28	46	1-603610	2	Washer-Spring Disc 7/16
14:4	32144-11	1	Screw-HWH 5/16-18 X 3/4 Tf	47	1-653313	2	Gasket-Exhaust
18		1	Engine-Kawasaki, Fx651V ▲◆	48	1-807259	1	Key-Machine 1/4 X 1/4 X 1
18:1		1	Kawasaki 49065-7007 Engine Oil Filter ▲◆	50	323-15	1	Screw-HH 3/8-16 X 3 1/2
18:2		1	Kawasaki 49019-7005 Fuel Filter ▲◆	51	323-8	4	Screw-HH 3/8-16 X 1 1/2
18:3		1	Kawasaki 11013-7045 Safety Filter ▲◆	52	3217-5	1	Nut-Hex 1/4-20
				54	3231-29	2	Bolt-Carriage 3/8-16 X 1 3/4
				55	3256-22	1	Washer-1/4 SAE
				56	3256-4	1	Washer-3/8 Std
				57	98-5975	4	Washer-Spring Disc 3/8

● Torque to 24-26 ft-lb

▲ Not serviced separately

□ Use Pro-Lock, Nut Type (P/N 1-840022, .5ml tube) on threads.

■ Torque to 23-29 ft-lb

◆ Obtain parts from www.kawpower.com

Transaxle Assembly

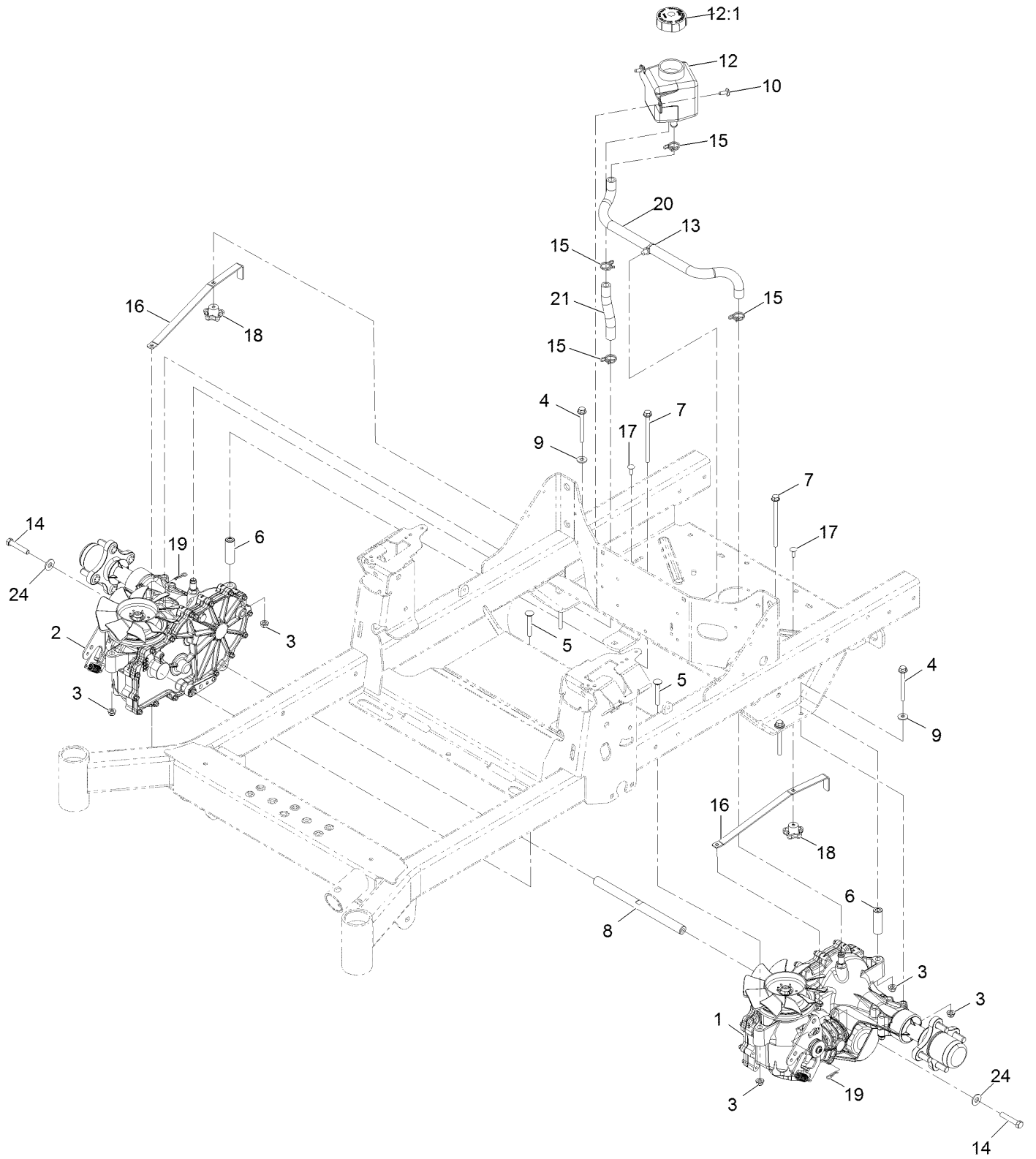

Transaxle Assembly (continued)

<i>Ref.</i>	<i>Part Number</i>	<i>Qty.</i>	<i>Description</i>	<i>Ref.</i>	<i>Part Number</i>	<i>Qty.</i>	<i>Description</i>
1	135-0140	1	LH Transaxle ASM	12	109-2250	1	Tank-HYD
2	135-0139	1	RH Transaxle ASM	12:1	109-3320	1	Cap-Reservoir, HYD
3	104-8300	8	Nut-Nyloc 5/16-18 Flg	13	32180-118	1	Clip-Tie
4	126-4687	4	Screw-HHF	14	94-7972	2	Screw-HH W/Loctite ●
5	3230-7	2	Bolt-Carriage 5/16-18 X 2 1/4	15	126-0327	4	Clamp-Hose
6	116-5809	2	Spacer-Hydro	16	109-5395	2	Arm-Bypass, Hydro
7	126-5896	2	Screw HHF	17	3229-1	2	Bolt-Carriage 1/4-20 X 3/4
8	116-6833	1	Shaft-Spacer	18	108-6402	2	Knob-Handle
9	1-303334	4	Washer-Spring Disc 5/16	19	1-806003	2	Hairpin-Cotter
10	126-6266	2	Screw-1/4-20 X .65 Torx Plus	20	126-5668	1	Hose-Hydraulic
				21	126-5669	1	Hose-Hydraulic
				24	3256-4	2	Washer-3/8 Std

● Use Pro-Lock, Nut Type (P/N 1-840022, .5ml tube) on threads.

LH Transaxle Assembly No. 135-0140

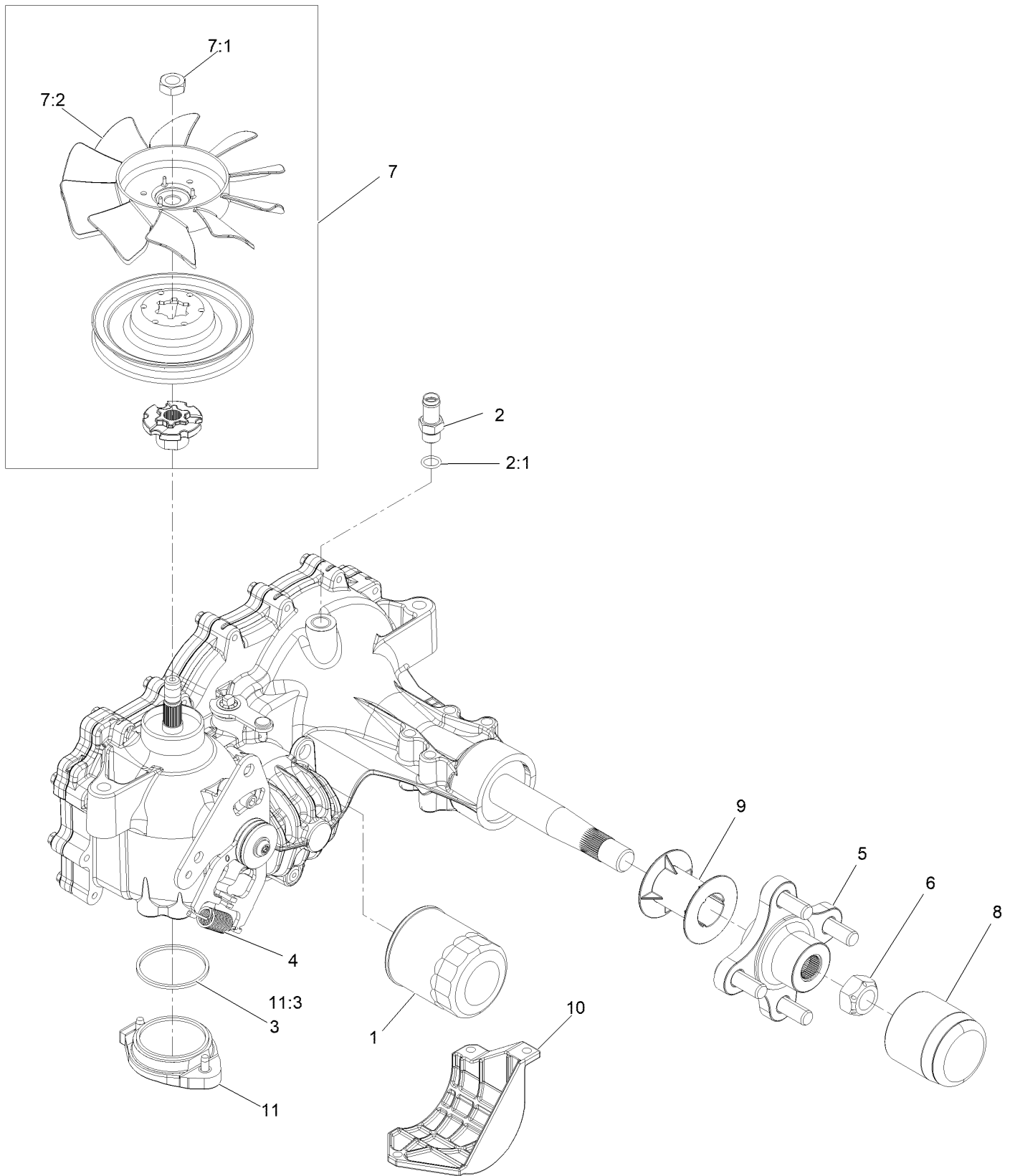

LH Transaxle Assembly No. 135-0140 (continued)

<i>Ref.</i>	<i>Part Number</i>	<i>Qty.</i>	<i>Description</i>	<i>Ref.</i>	<i>Part Number</i>	<i>Qty.</i>	<i>Description</i>
1	109-3321	1	Element-Oil Filter, HYD	7:2	126-0226	1	Fan
2	109-3278	1	Adapter-Straight	8	116-6214	1	Cap-Axle, Long
2:1	237-42	1	O-Ring	9	116-6213	1	Tube-Axle
3	109-3540	1	O Ring-Seal	10	120-7979	1	Guard-Filter, LH
4	109-5592	1	Spring-Extension	11	114-8465	1	Charge Kit
5	116-3872	1	Hub-Offset	11:3	109-3540	1	O Ring-Seal
6	109-3536	1	Nut-Hub	99	135-3604	1	Brake Shaft Seal Kit
7	135-7347	1	Fan And Pulley Kit	99	109-3537	1	Seal Kit ●
7:1	116-9714	1	Nut-HJ				

● Not illustrated

RH Transaxle Assembly No. 135-0139

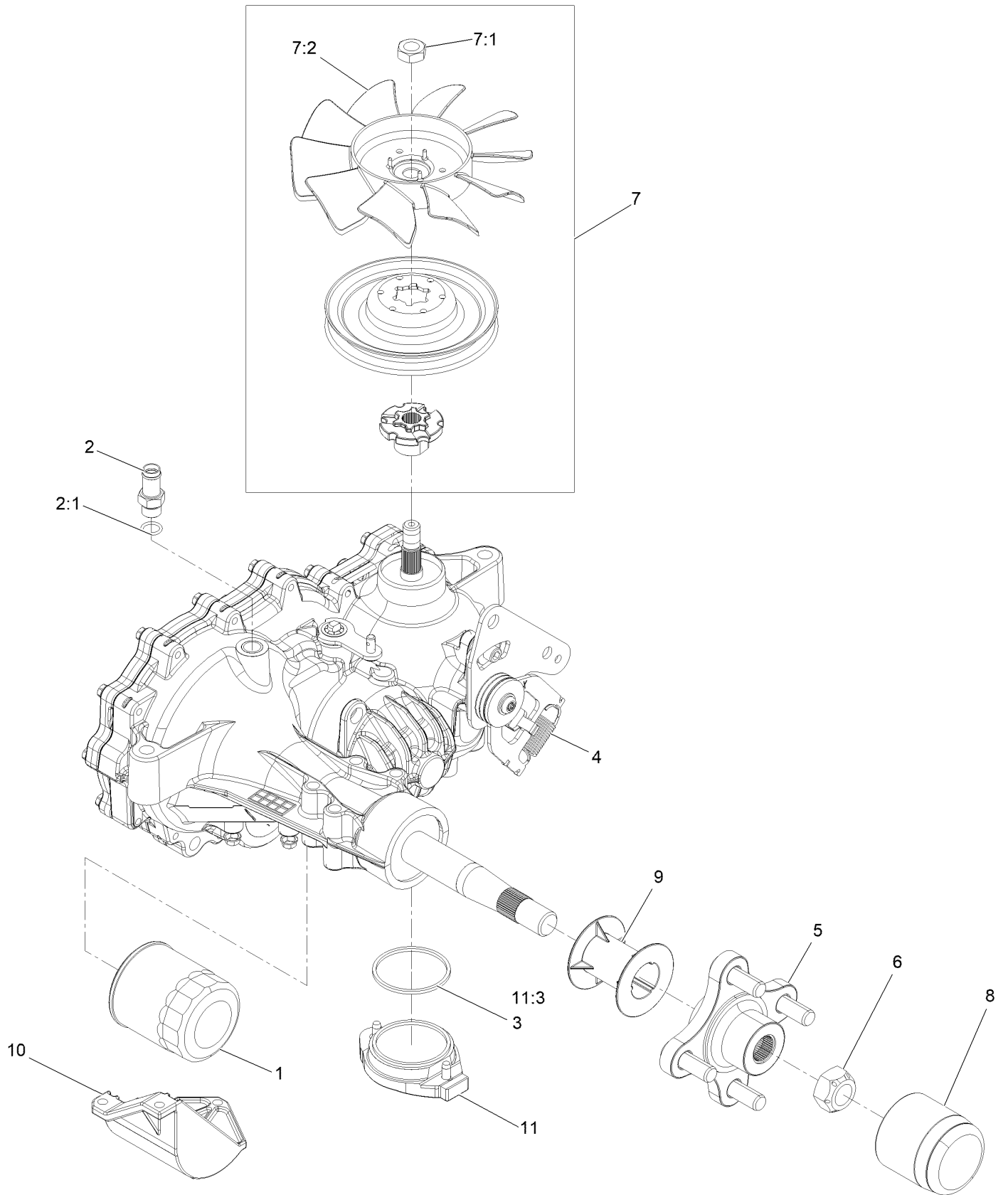

RH Transaxle Assembly No. 135-0139 (continued)

<i>Ref.</i>	<i>Part Number</i>	<i>Qty.</i>	<i>Description</i>	<i>Ref.</i>	<i>Part Number</i>	<i>Qty.</i>	<i>Description</i>
1	109-3321	1	Element-Oil Filter, HYD	7:2	126-0226	1	Fan
2	109-3278	1	Adapter-Straight	8	116-6214	1	Cap-Axle, Long
2:1	237-42	1	O-Ring	9	116-6213	1	Tube-Axle
3	109-3540	1	O Ring-Seal	10	120-7981	1	Guard-Filter, RH
4	109-5592	1	Spring-Extension	11	114-8465	1	Charge Kit
5	116-3872	1	Hub-Offset	11:3	109-3540	1	O Ring-Seal
6	109-3536	1	Nut-Hub	99	135-3604	1	Brake Shaft Seal Kit
7	135-7347	1	Fan And Pulley Kit	99	109-3537	1	Seal Kit ●
7:1	116-9714	1	Nut-HJ				

● Not illustrated

Electrical Assembly

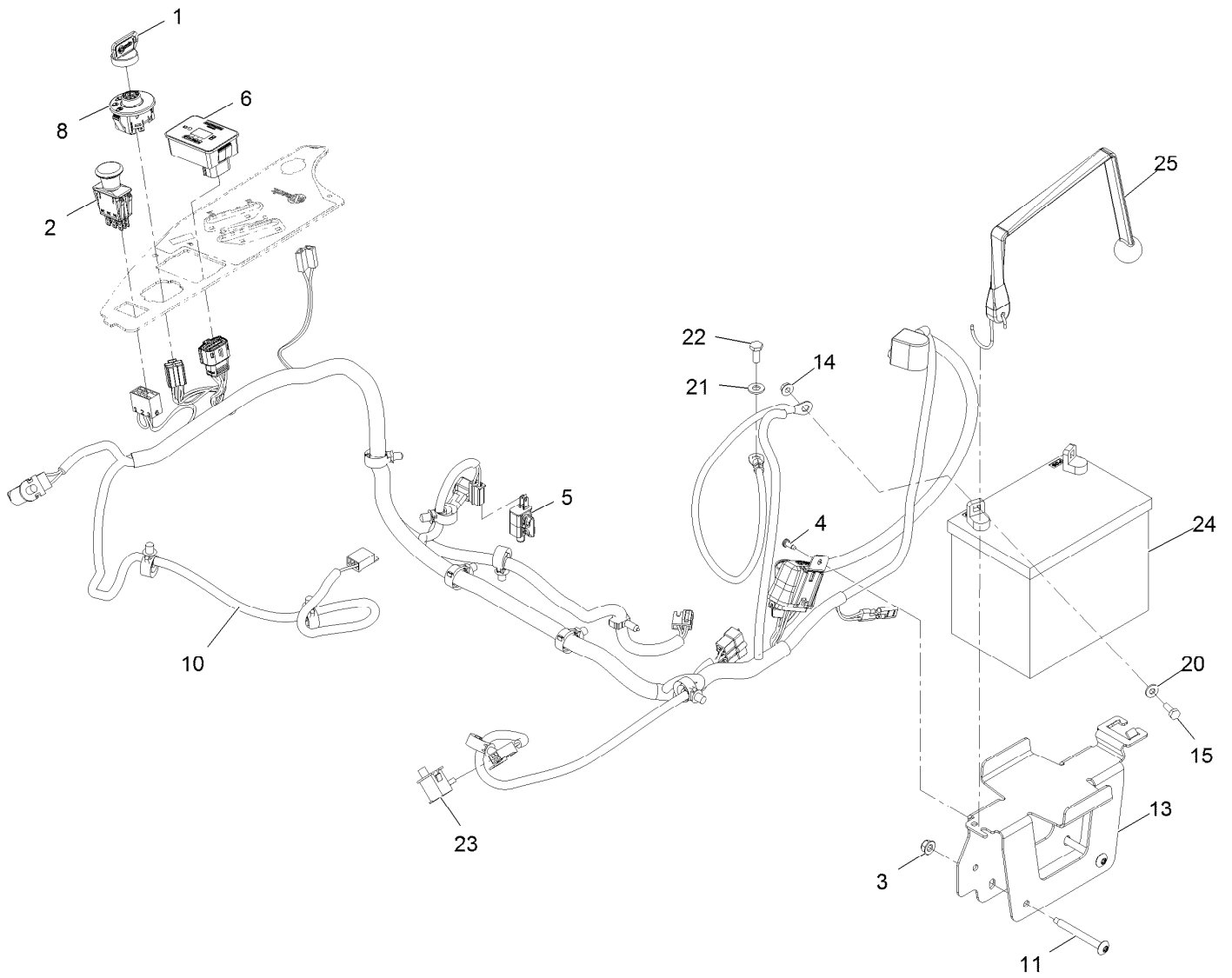

Electrical Assembly (continued)

<i>Ref.</i>	<i>Part Number</i>	<i>Qty.</i>	<i>Description</i>	<i>Ref.</i>	<i>Part Number</i>	<i>Qty.</i>	<i>Description</i>
1	1-603511	1	Key-Ignition	13	126-6725-03	1	Tray-Battery
1	103-2106	1	Key-Exmark Logo	14	32128-33	2	Nut-Whizlock 1/4-20
2	103-5221	1	Switch-PTO	15	321-4	2	Screw-HH 1/4-20 X 3/4
3	104-8300	2	Nut-Nyloc 5/16-18 Flg	20	3256-22	2	Washer-1/4 SAE
4	105-6849	1	Screw-Tph #10-24 X 1/2 Tf	21	33094-00	1	Washer
5	110-6765	1	Switch	22	33114-020	1	Screw-HH M8-1.25 X 20Mm
6	116-5609	1	Module ASM	23	82-2190	2	Switch
8	137-4100	1	Switch-Ignition	24		1	Battery ●■
10	126-5803	1	Harness-Wire ▲	25	126-7627	1	Strap-Bungee
11	126-6267	2	Screw-Truss HD 5/16-18 X 2 3/4 Torx Plus				

● Obtain locally.

■ Not serviced separately

▲ Use dielectric grease on all unsealed connectors and terminals only. Do not apply in sealed connectors.

Harness Assembly No. 126-5803

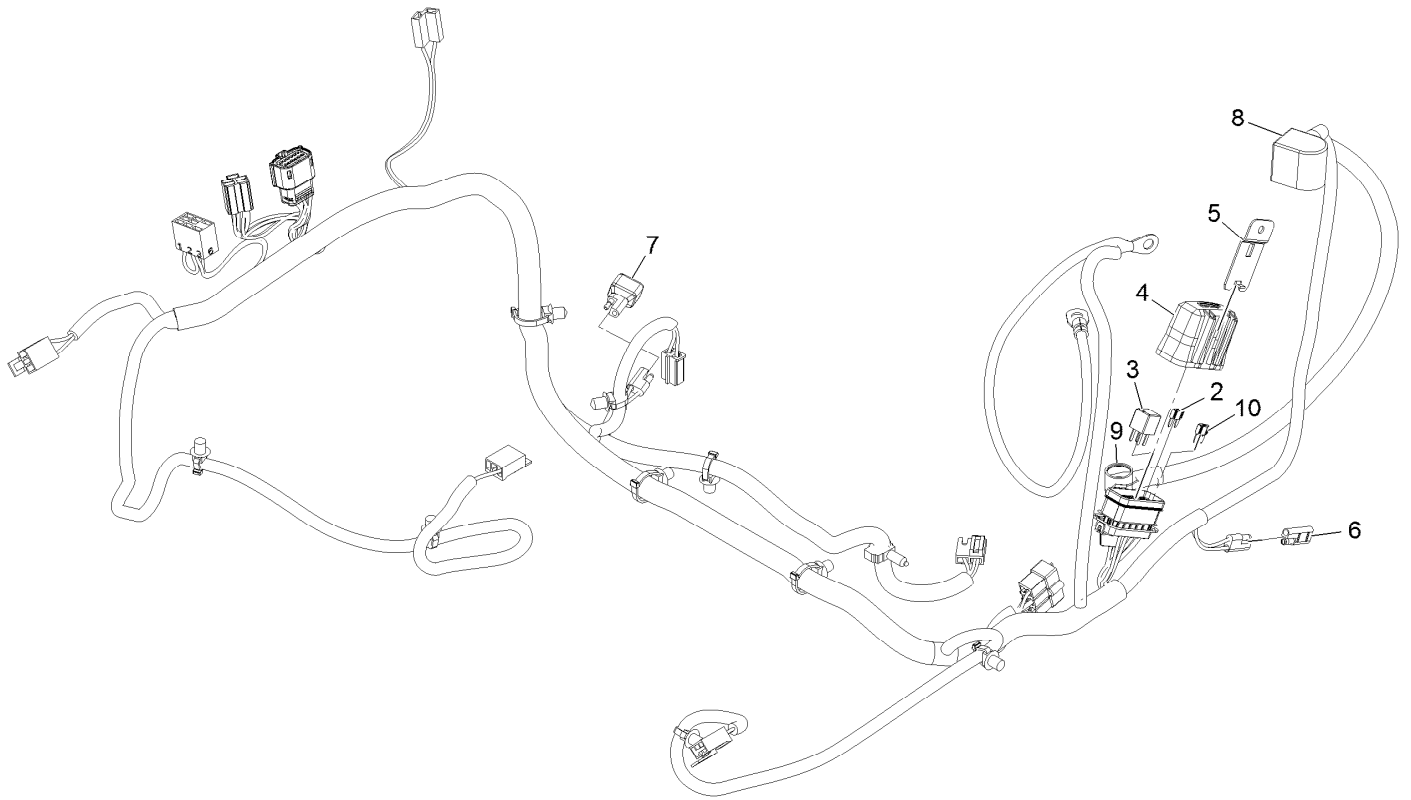

Harness Assembly No. 126-5803 (continued)

<i>Ref.</i>	<i>Part Number</i>	<i>Qty.</i>	<i>Description</i>
2	121-8868	1	Fuse-Mini Blade, 20 Amp
3	126-3991	1	Relay-Micro
4	32180-176	1	Cover-Block, Fuse
5	32180-177	1	Clip-Mounting
6	116-0053	1	Cap-Plug

<i>Ref.</i>	<i>Part Number</i>	<i>Qty.</i>	<i>Description</i>
7	103-3895	1	Diode
8	126-8876	1	Insulator-Battery
9	1-543393	1	Insulator-Solenoid
10	121-8867	1	Fuse-Mini Blade, 15 Amp

Notes:

Notes:

Notes:



MAXIMIZE THE PERFORMANCE OF YOUR EXMARK MACHINE.



EXMARK® PREMIUM ENGINE OIL

Exmark now offers a family of engine oil viscosities to perform well in any environment. Each viscosity has the same synthetic formulation to give you what you need in punishing conditions. We designed each grade to the highest quality, making it ideal even for diesel applications. Coupled with Exmark Premium Fuel Treatment, we have the performance products to make your machine hum.

EXMARK PREMIUM ENGINE OIL SAE 30/10W-30

- Meets zero shear requirements of a straight grade SAE 30 as well as the cold temp properties of a 10W-30.
- Most versatile oil in the industry.
- Superior corrosion protection over conventional oil - even in corrosive, humid environments.

EXMARK PREMIUM ENGINE OIL SAE 20W-50

- Perfect for your big block engine, or any application in severe service.
- Same full synthetic formulation as all other Exmark Premium viscosities.
- Also effective for use in severe service small block engines.

EXMARK PREMIUM ENGINE OIL SAE 10W-50

- Full synthetic formulation gives you peak performance. Don't settle for less.
- Wide span multi-grade combines easy starting in cold weather with maximum protection in high temperature operation.
- Reduce friction & wear over standard mineral formulations.

EXMARK PREMIUM ENGINE OIL SAE 0W-40

- The perfect choice for when the weather turns cold or unpredictable, and your Exmark UTV has to perform.
- Commercial quality for severe service.
- Advanced additive package helps prevent corrosion from long-term storage.

EXMARK PREMIUM ENGINE OIL UTV FORMULATION

- 4-cycle high-temp formulation.
- Heavier viscosity, full synthetic, perfect for your UTV.

EXMARK PREMIUM UTV EXTREME CONDITIONS GEAR OIL

- SAE 80W-90, designed to keep your UTV performing at its peak.
- Shear stable, hypoid gear lube.
- Includes a premium additive system to combat wear, oxidation, rust & corrosion.

Available from your local Exmark dealer. Find your closest dealer at exmark.com

EXMARK ACCESSORIES AND OPTIONS*

MID-MOUNT RIDING ACCESSORIES AND OPTIONS

CUSTOM RIDE SEAT SUSPENSION SYSTEM	OPERATOR CONTROLLED DISCHARGE
FULL SUSPENSION SEAT	SUN SHADE
DECK LIFT ASSIST KIT	TRASH CONTAINER
HITCH KIT	TURF STRIPER
LIGHT KIT	ULTRA VAC COLLECTION SYSTEM
12V POWER PORT	ULTRA VAC QUICK DISPOSAL SYSTEM
MICRO-MULCH SYSTEM	

OUT-FRONT RIDING ACCESSORIES AND OPTIONS

CUSTOM RIDE SEAT SUSPENSION SYSTEM	SNOW BLADE
DUAL-TAIL WHEEL	SNOWBLOWER
FLOOR PAN EXTENDER	SUN SHADE
HITCH KIT	TRASH CONTAINER
LIGHT KIT	ULTRA VAC COLLECTION SYSTEM
MICRO-MULCH SYSTEM	ULTRA VAC QUICK DISPOSAL SYSTEM
ROLL OVER PROTECTION SYSTEM (ROPS)	WEATHER CAB

WALK-BEHIND ACCESSORIES AND OPTIONS

GRASS CATCHER	TURF STRIPER
MICRO-MULCH SYSTEM	STANDON

*Some accessories and options not available for some models.

Place Model No. and Serial No.
Label Here (Included in the Literature
Pack) or Fill in Below

Model No. _____

Serial No. _____

Date Purchased _____

Engine Model No. and Spec. No. _____

Engine Serial No. (E/No) _____

© 2021 Exmark Mfg. Co., Inc.
415 Industrial Row
Beatrice, NE 68310
All Rights Reserved

Part No. 4505-743 Rev. B
(402) 223-6375
Fax (402) 223-5489
Printed in the USA.

