

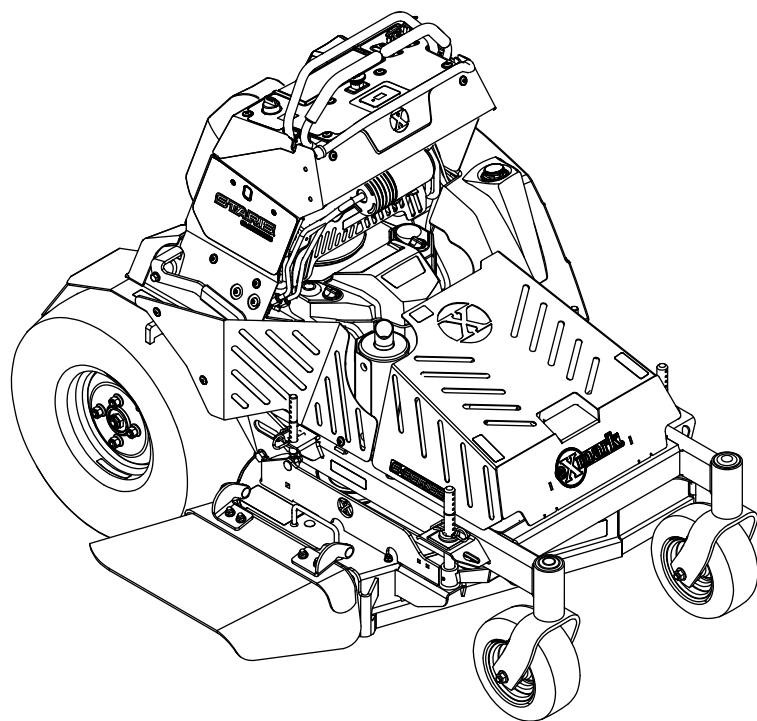

STARIS® E-SERIES

Model No. STE600CKA323H1—Serial No. 411294212 and Up

Picture below may not reflect actual product.



Parts Manual

Part No. 4505-665 Rev. A

Ordering Replacement Parts

To order replacement parts, please supply the part number, the quantity, and the description of each part desired.

Understanding Reference Numbers

Each identified part in an illustration has a reference number. The reference number for a part also appears in the parts list, along with other information about the part.

This catalog uses two special reference number formats, one to indicate parts in a service assembly and another to indicate the quantity of a given part in an illustration.

Service Assembly Reference Numbers

Parts in service assemblies have reference numbers in the form a:b. The a represents the reference number of the entire service assembly and the b represents a sequential number unique to each part within the service assembly.

For example, a wheel assembly might be identified by reference number 6, the tire by 6:1, the valve by 6:2, and the wheel by 6:3. When you order the assembly identified by reference number 6, you receive all parts identified by reference numbers 6:1, 6:2, and 6:3. However, you may also order any part individually. Reference numbers of this type appear in illustration and in parts lists.

Reference Numbers Indicating Quantity

In an illustration, if a reference number indicates more than one part, the reference number has the form nX y. The n represents the quantity of the part, the X is the multiplication symbol, and the y represents the reference number.

For example, in an illustration, the reference number 2X 37 means that two of the parts identified by reference number 37 are indicated.

Touch Up Paint

Exmark black touch up spray paint – gloss black.

Exmark red touch up paint (spray paint – P/N 1-850337 - .6 oz liquid bottle – P/N 103-9140).

Contents

Complete Deck Assembly	4
Deck Assembly	6
Deck W/Decals Assembly	8
Idler Assembly	10
Discharge Deflector Assembly	12
Main Frame Assembly	14
Control Assembly	16
Left Motion Control Assembly	18
Right Motion Control Assembly	20
Platform Assembly	22
Guarding Assembly	24
Caster Wheel Assembly	26
Deck Lift Assembly	28
Height of Cut Lever	30
Lift Rod Assembly	32
Park Brake Assembly	34
Tire and Wheel Assembly	36
Fuel Assembly	38
Fuel Tank Assembly-cont.	40
Fuel Line and Valve Assembly	42
Engine Assembly	44
Hydraulic Assembly	46
Idler Arm Assembly	48
Electrical Assembly	50
Harness Assembly	52

Complete Deck Assembly

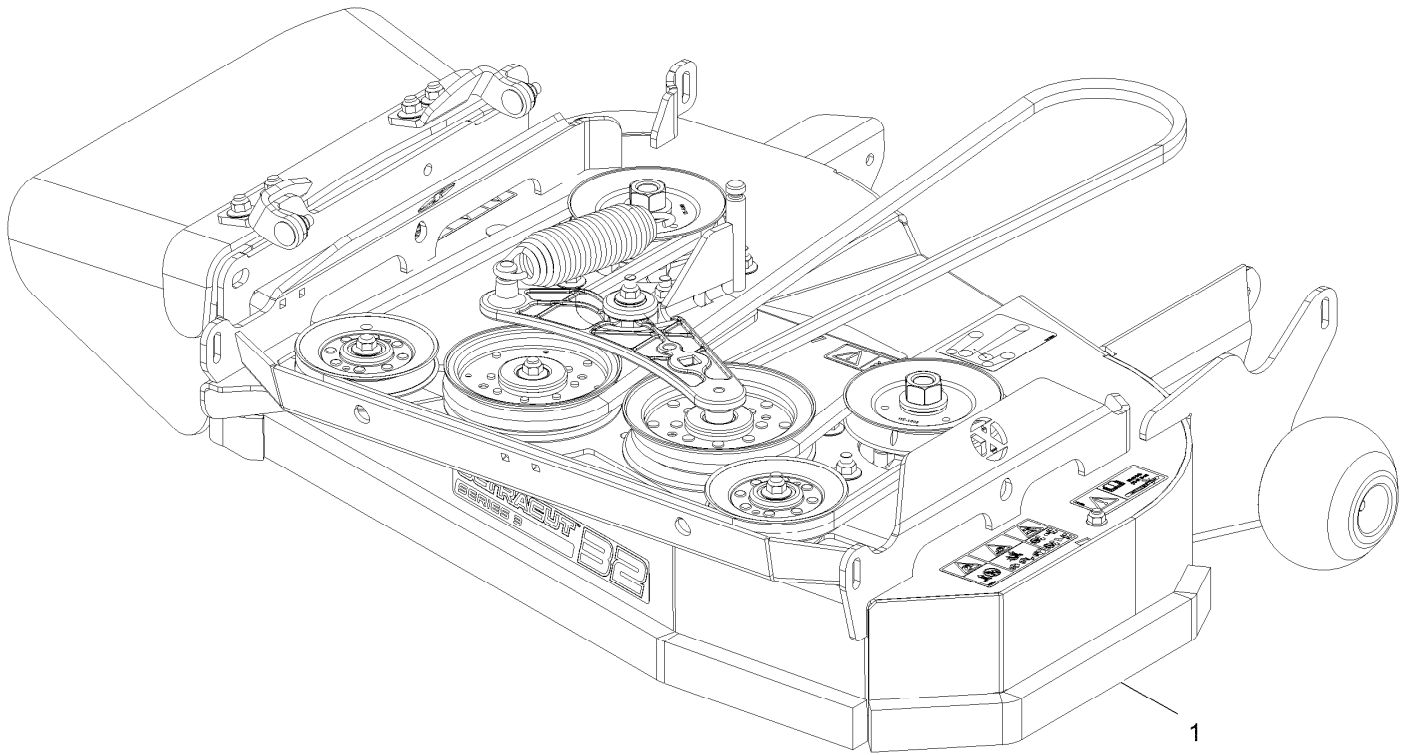

Complete Deck Assembly (continued)

<i>Ref.</i>	<i>Part Number</i>	<i>Qty.</i>	<i>Description</i>
1	142-6111	1	ASM, 32" Deck, Complete

Deck Assembly

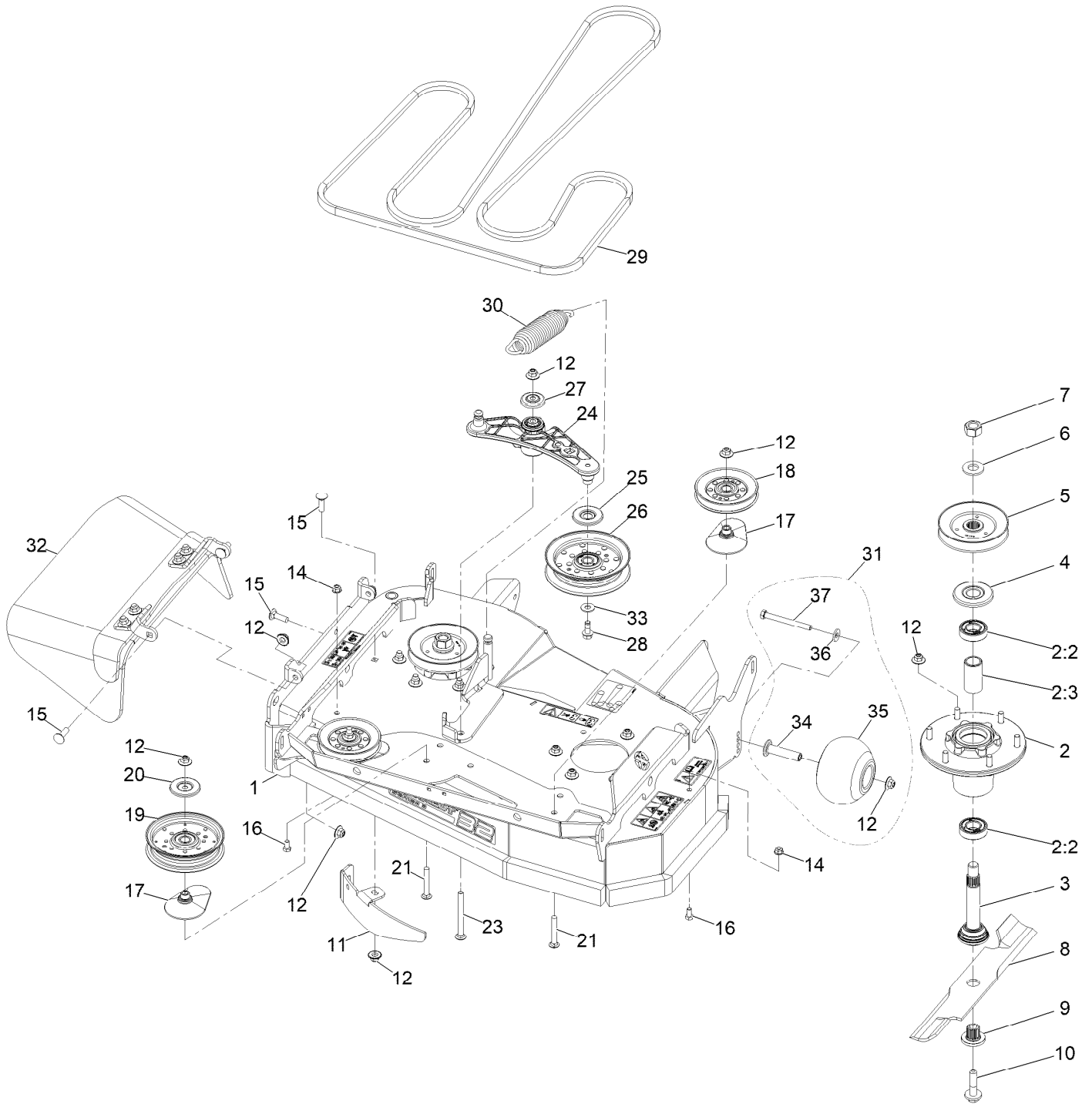

Deck Assembly (continued)

<i>Ref.</i>	<i>Part Number</i>	<i>Qty.</i>	<i>Description</i>	<i>Ref.</i>	<i>Part Number</i>	<i>Qty.</i>	<i>Description</i>
1	142-6073	1	ASM-Deck Decals 32	17	109-2872	3	Spacer-Pulley
2	116-3344	2	ASM-Cutter Hsg With Bearings	18	135-4398	2	Idler - V 4.13 Eod-A
2:2	116-0720	2	Bearing-Ball	19	126-9187	1	Pulley-Idler, Flat
2:3	116-3312	1	Spacer-Bearing	20	126-8043	1	Shield-Dust
3	116-3342	2	ASM-Spindle And Seal	21	3231-31	3	Bolt-Carriage 3/8-16 X 2 1/2
4	116-1286	2	Guard,Bearing Top .989	23	135-0313	1	Screw-CARR
5	135-4808	2	Sheave-Blade Drive	24	135-1679	1	ASM.-Arm, Idler
6	103-2802	2	Washer-Spring Disc 3/4	25	126-9195	1	Shield-Guard, Dust
7	116-7306	2	Nut-Hex	26	126-9196	1	Idler-Pulley, Flat
8	116-5177	2	Blade-Extreme 2, 16.25" ●	27	103-2916	1	Guard-Top
8	103-6401	2	Blade-Notched	28	126-1680	1	Screw-HHF
8	103-6391	2	Blade, Mulching ■	29	135-7353	1	Belt-V
8	103-6386	2	Blade, Low Lift ●	30	116-6317	1	Spring-Extension
8	103-6381	2	Blade, Solid ●	31	116-9981	1	Kit, Anti-Scalp Roller
9	103-3037	2	Bushing, Splined	32	142-6489	1	Rubber Deflector ASM
10	109-9220	2	Screw-Sems 1/2-20 X 2.19	33	3256-4	1	Washer-3/8 Std
11	126-2783-01	1	Baffle, Dogleg	34	116-8131	1	Axle, Roller
12	109-6658	21	Nut-Nyloc 3/8-16 Flg	35	103-8415	1	Roller-Anti-Scalp
14	104-8300	2	Nut-Nyloc 5/16-18 Flg	36	98-5975	1	Washer-Spring Disc 3/8
15	3231-25	4	Bolt-Carriage 3/8-16 X 1 1/4	37	116-9362	1	Screw-HH 3/8-16 X 3 3/4 GR 8
16	322-2	2	Screw-HH 5/16-18 X 5/8				

● Optional Equipment

■ Requires installation of mulch kit for proper mulching. See your Exmark dealer for details.

Deck W/Decals Assembly

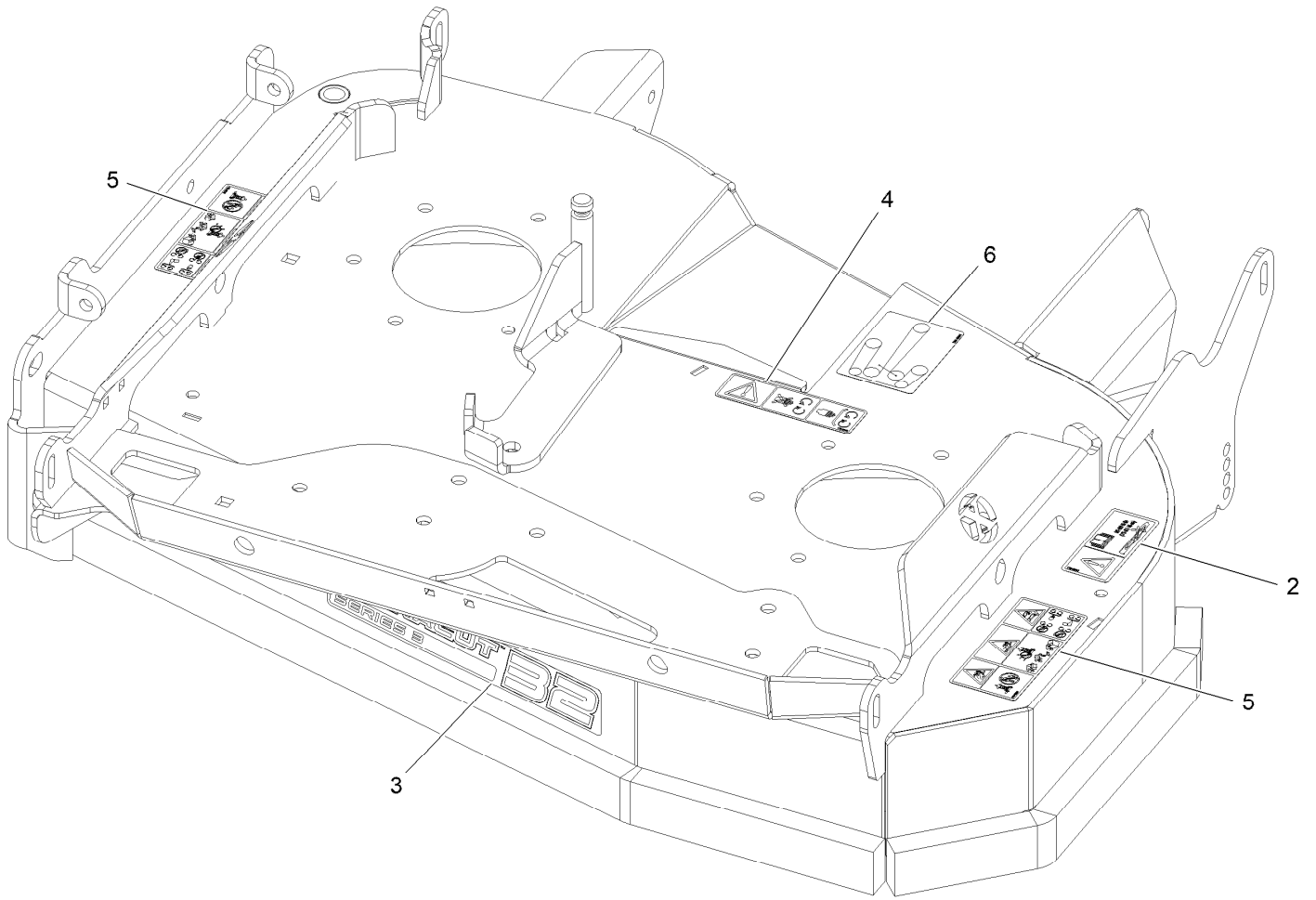

Deck W/Decals Assembly (continued)

<i>Ref.</i>	<i>Part Number</i>	<i>Qty.</i>	<i>Description</i>	<i>Ref.</i>	<i>Part Number</i>	<i>Qty.</i>	<i>Description</i>
2	116-8283	1	Decal-Torque, Bolt	5	142-6830	2	Decal-Warning Thrown Object
3	135-2283	1	Decal-Ultracut 32-Series 3				
4	112-9028	1	Decal-Cover, Missing	6	135-3004	1	Decal-Belt Routing

Idler Assembly

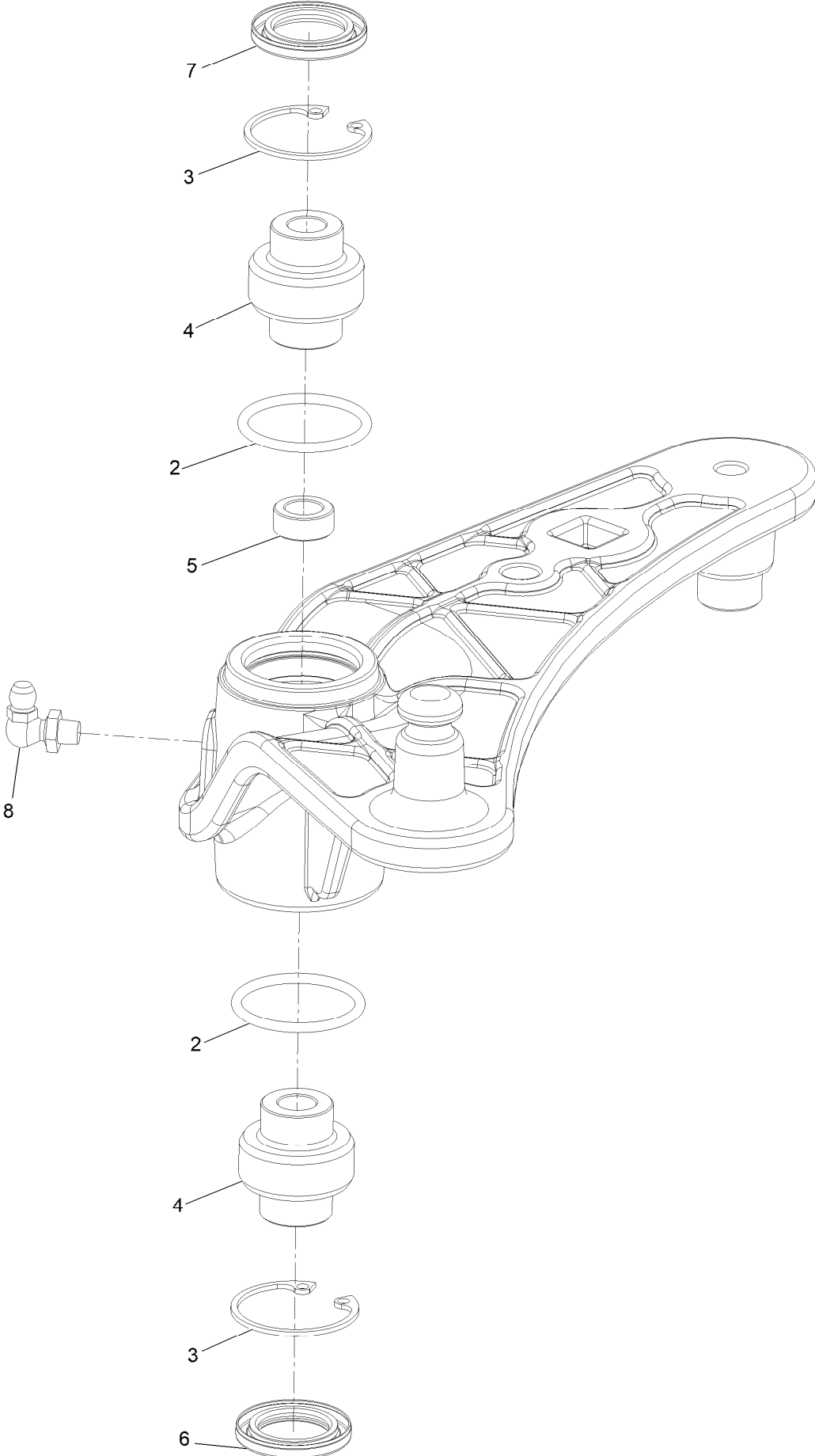

Idler Assembly (continued)

<i>Ref.</i>	<i>Part Number</i>	<i>Qty.</i>	<i>Description</i>	<i>Ref.</i>	<i>Part Number</i>	<i>Qty.</i>	<i>Description</i>
2	106-7159	2	O-Ring	6	103-3505	1	Seal-Lip, Double
3	32120-10	2	Ring-Retaining	7	103-3506	1	Seal-Single Lip
4	103-3504	2	Bearing-Spherical	8	302-40	1	Zerk-90° 1/4-28
5	103-5677	1	Spacer				

Discharge Deflector Assembly

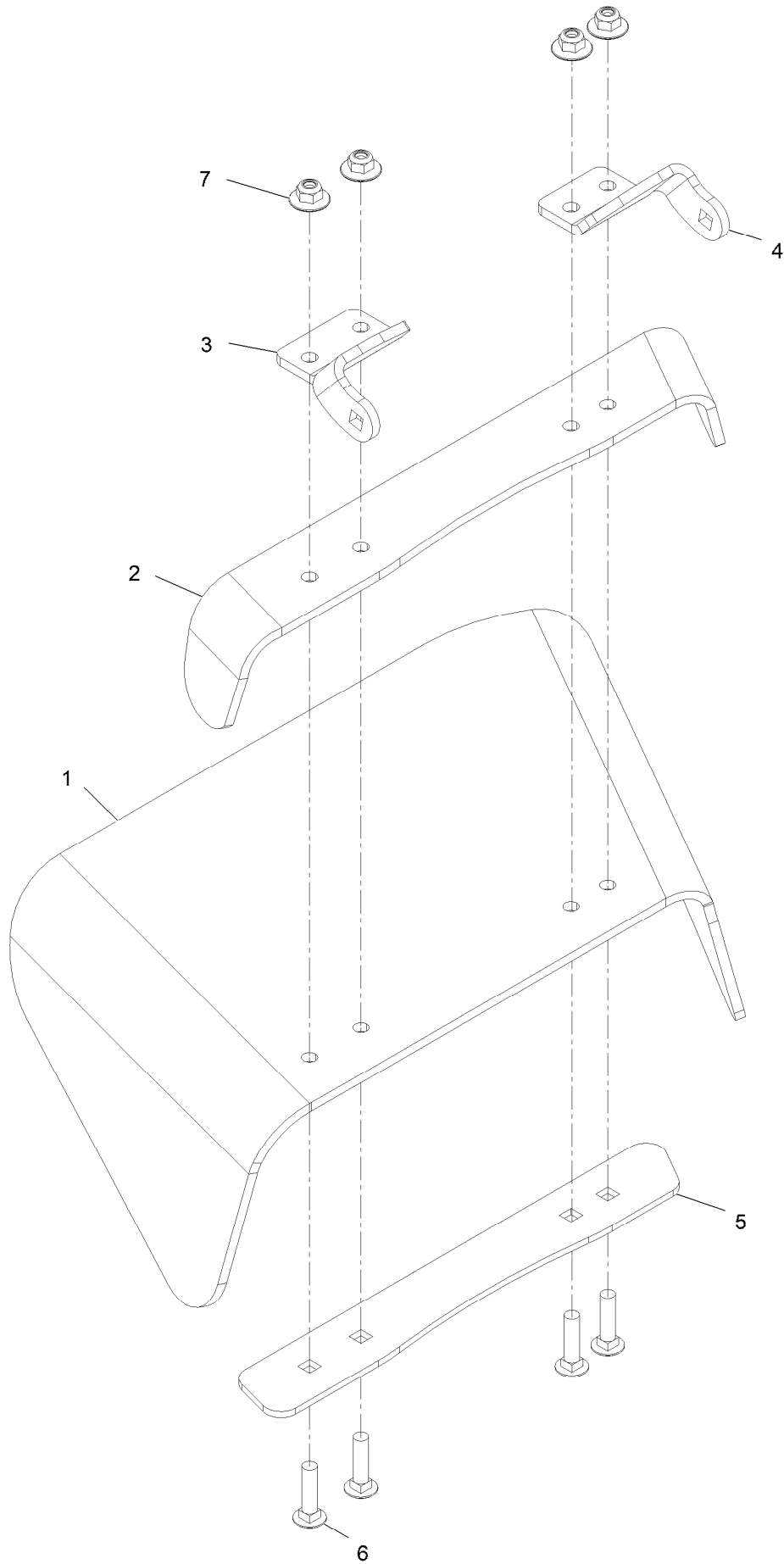

Discharge Deflector Assembly (continued)

<i>Ref.</i>	<i>Part Number</i>	<i>Qty.</i>	<i>Description</i>	<i>Ref.</i>	<i>Part Number</i>	<i>Qty.</i>	<i>Description</i>
1	135-2157	1	Deflector-Rubber	5	135-2156-03	1	Strap-Bottom Deflector
2	135-2155-01	1	Bracket-Top Deflector	6	3231-4	4	Bolt-Carriage 3/8-16 X 1 1/2
3	142-6487-01	1	Bracket-Deflector	7	109-6658	4	Nut-Nyloc 3/8-16 Flg
4	142-6488-01	1	Bracket-Deflector				

Main Frame Assembly

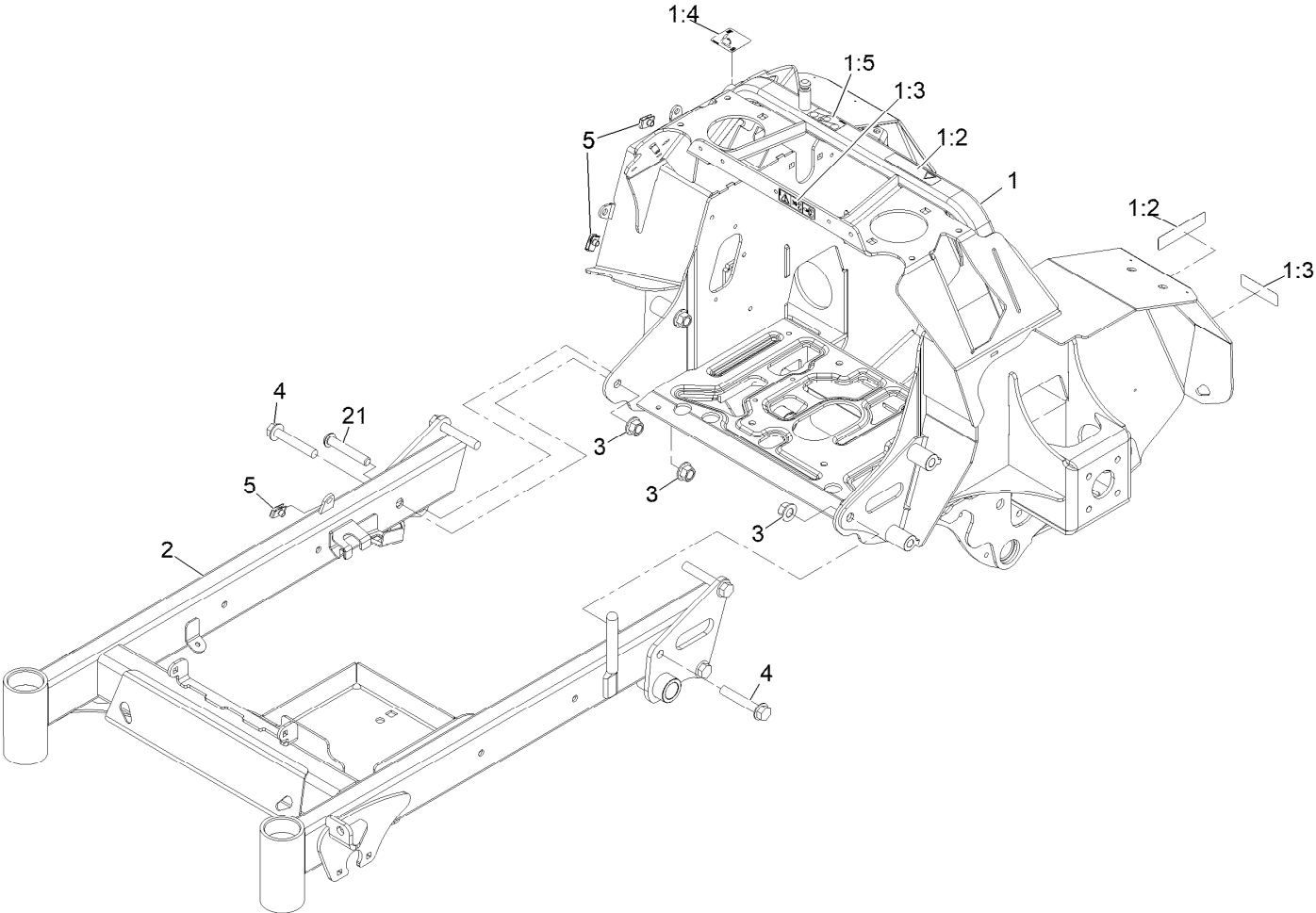

Main Frame Assembly (continued)

<i>Ref.</i>	<i>Part Number</i>	<i>Qty.</i>	<i>Description</i>	<i>Ref.</i>	<i>Part Number</i>	<i>Qty.</i>	<i>Description</i>
1	142-2557	1	ASM, Rear Frame W/ Decals	2	142-2538-01	1	Weld, Front Frame, 36
1:2	98-1977	2	Decal-Warning	3	99-5107	6	Nut-Lock 1/2-13
1:3	116-8559	2	Decal, Cover Missing	4	3234-40	5	Screw-HF
1:4	116-5988	1	Decal-Park Brake, CE	5	107069	3	Nut-Retainer-Panel 1/4-20
1:5	135-2267	1	Decal-Belt Routing HYD	21	142-3783	1	Screw, HSBH

Control Assembly (continued)

<i>Ref.</i>	<i>Part Number</i>	<i>Qty.</i>	<i>Description</i>	<i>Ref.</i>	<i>Part Number</i>	<i>Qty.</i>	<i>Description</i>
1	135-3683	1	ASM-Ctrl Tower	13:1		1	ASM, Motion Control Link ●
1:2	142-3077	1	Decal-HYD Fluid Warn	13:1:2	116-4755	1	Rod-Adjustment
1:4	138-2758	2	Nut-Clinch,Hex	13:1:3	3220-16	1	Nut-Jam 3/8-24 LH
2	107069	8	Nut-Retainer-Panel 1/4-20	13:1:4	135-1291	1	Link, Motion Control
3	135-2579	1	ASM, Control Panel W/ Decals	13:1:5	3220-3	1	Nut-Jam 3/8-24
3:2	135-6773	1	Decal-Control Panel Non-EFI	14	135-2168	1	Control, Choke
4	135-3432-05	1	Weld, Front Ref Bar	15	135-2169	1	Control, Throttle
5	135-3430-05	1	Weld, Rear Ref Bar	16	135-3176	4	Screw, BHCS
6	3296-59	4	Nut-Nyloc 3/8-16 Thin	17	3296-2	4	Nut-Nyloc #10-24
7	3231-21	4	Bolt-Carriage 3/8-16 X 3/4	18	1-513658	2	Bumper
8	3274-94	2	Screw-Button Head 3/8-16 X 1	19	322-8	4	Screw-HH
9	104-8301	2	Nut-Nyloc 3/8-16 Flg	20	104-8300	8	Nut-Nyloc 5/16-18 Flg
10	135-1277	2	Pin, Pivot	21	32144-10	4	Screw-HWH 1/4-20 X .62
11	135-1304	1	ASM, Motion Control, Lt	22	3230-16	4	Bolt-Carriage 5/16-18 X 7/8
12	135-1305	1	ASM, Motion Control, Rt	23	135-3494	6	Screw, Torx
13	135-7116	2	ASM, Linkage	24	126-1499	2	Cam
				25	3296-56	2	Nut-Nyloc 1/4-20 Thin
				26	1-633545	4	Spacer
				27	135-2281	1	Decal-Cover

● Not serviced separately

Left Motion Control Assembly

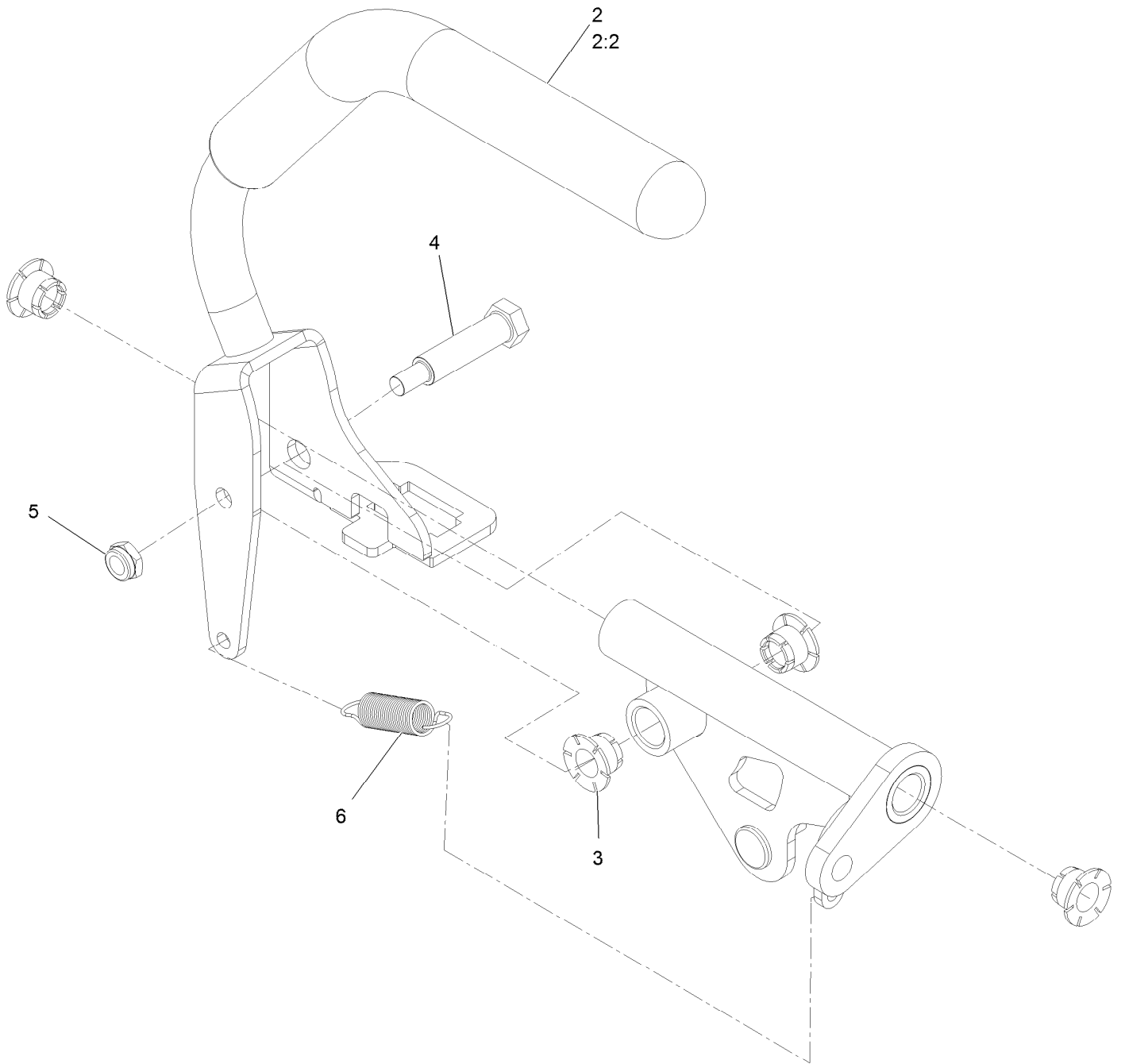

Left Motion Control Assembly (continued)

<i>Ref.</i>	<i>Part Number</i>	<i>Qty.</i>	<i>Description</i>	<i>Ref.</i>	<i>Part Number</i>	<i>Qty.</i>	<i>Description</i>
2	135-2546	1	ASM, Lt Control Lever W/ Grip	4	121-1229	1	Bolt-Shoulder
2:2	135-3301	1	Grip, Drive Lever	5	3296-56	1	Nut-Lock, NI
3	135-6412	4	Bearing, Igus	6	114-0249	1	Spring-Extension

Right Motion Control Assembly

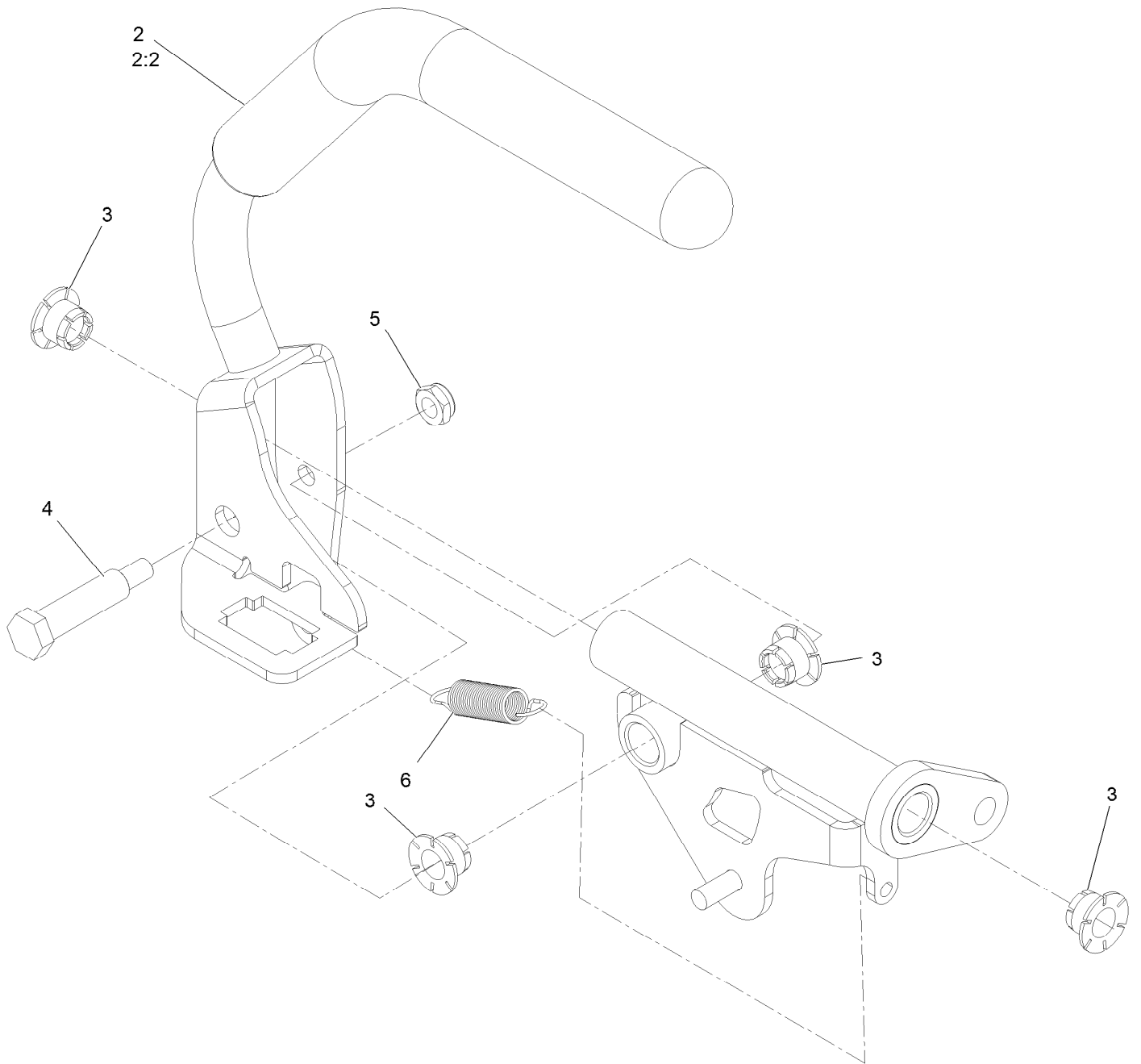

Right Motion Control Assembly (continued)

<i>Ref.</i>	<i>Part Number</i>	<i>Qty.</i>	<i>Description</i>	<i>Ref.</i>	<i>Part Number</i>	<i>Qty.</i>	<i>Description</i>
2	135-2547	1	ASM, Rt Control Lever W/ Grip	4	121-1229	1	Bolt-Shoulder
2:2	135-3301	1	Grip, Drive Lever	5	3296-56	1	Nut-Lock, NI
3	135-6412	4	Bearing, Igus	6	114-0249	1	Spring-Extension

Platform Assembly

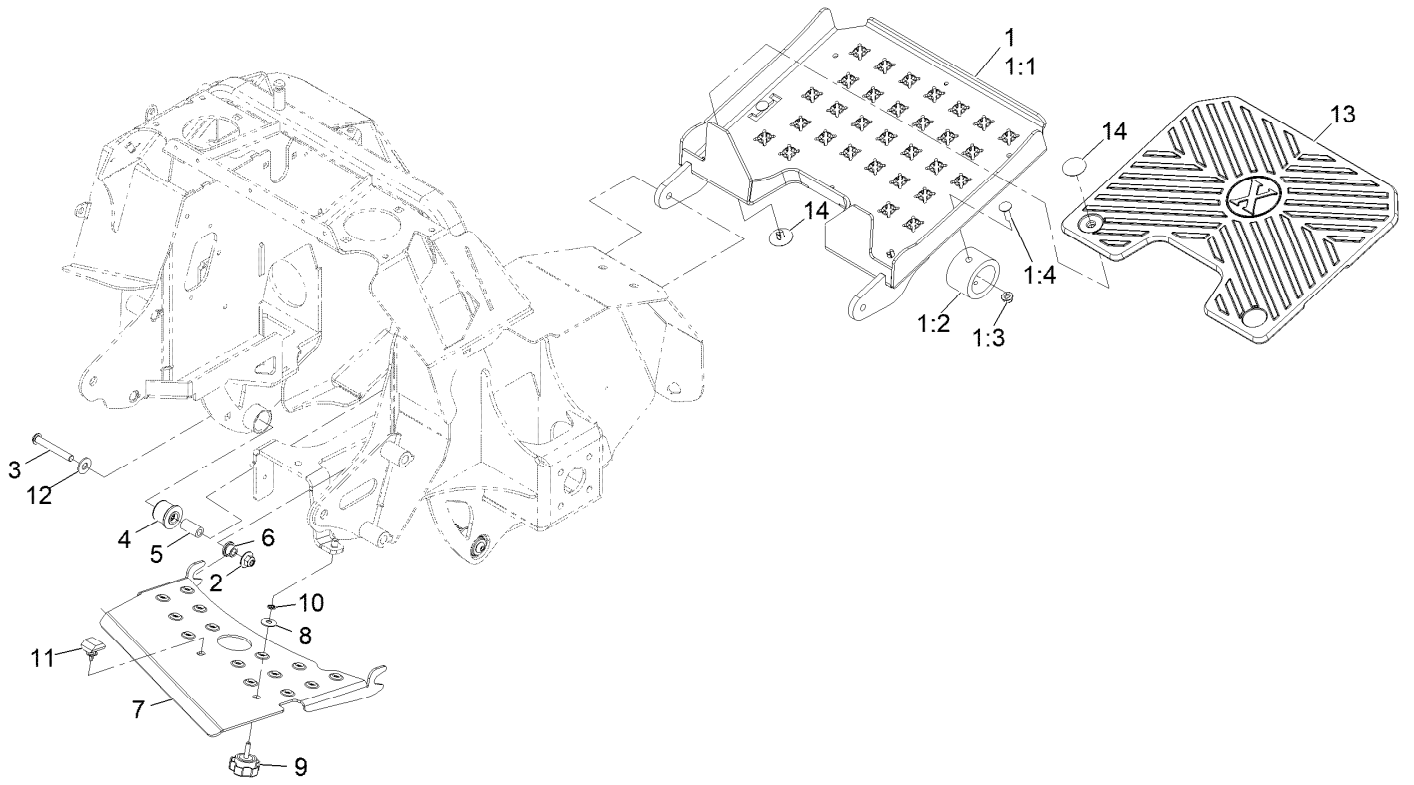

Platform Assembly (continued)

<i>Ref.</i>	<i>Part Number</i>	<i>Qty.</i>	<i>Description</i>	<i>Ref.</i>	<i>Part Number</i>	<i>Qty.</i>	<i>Description</i>
1	142-2710	1	ASM-Platform	6	109-8788	2	Bushing-Flanged
1:1	142-2470-05	1	Weld-Platform [blk-Txt]	7	142-6014-03	1	Deflector, Air, 32
1:2	135-2548	2	Bumper-Isolator	8	3290-456	1	Washer-Spring Disc
1:3	104-8300	2	Nut-Nyloc 5/16-18 Flg	9	135-7382	1	Knob
1:4	3230-2	2	Bolt-Carriage 5/16-18 X 1	10	1-803037	1	Nut-Retaining
2	109-6658	2	Nut-Nyloc 3/8-16 Flg	11	126-9966	1	Bumper-ROPS
3	135-7158	2	Screw-HSBH	12	3256-4	2	Washer-3/8 Std
4	126-8360	2	Bushing-Rubber, Suspension	13	142-3224	1	Pad-Platform
5	108-6544	2	Spacer	14	142-3247	4	Rivet-Ratchet

Guarding Assembly

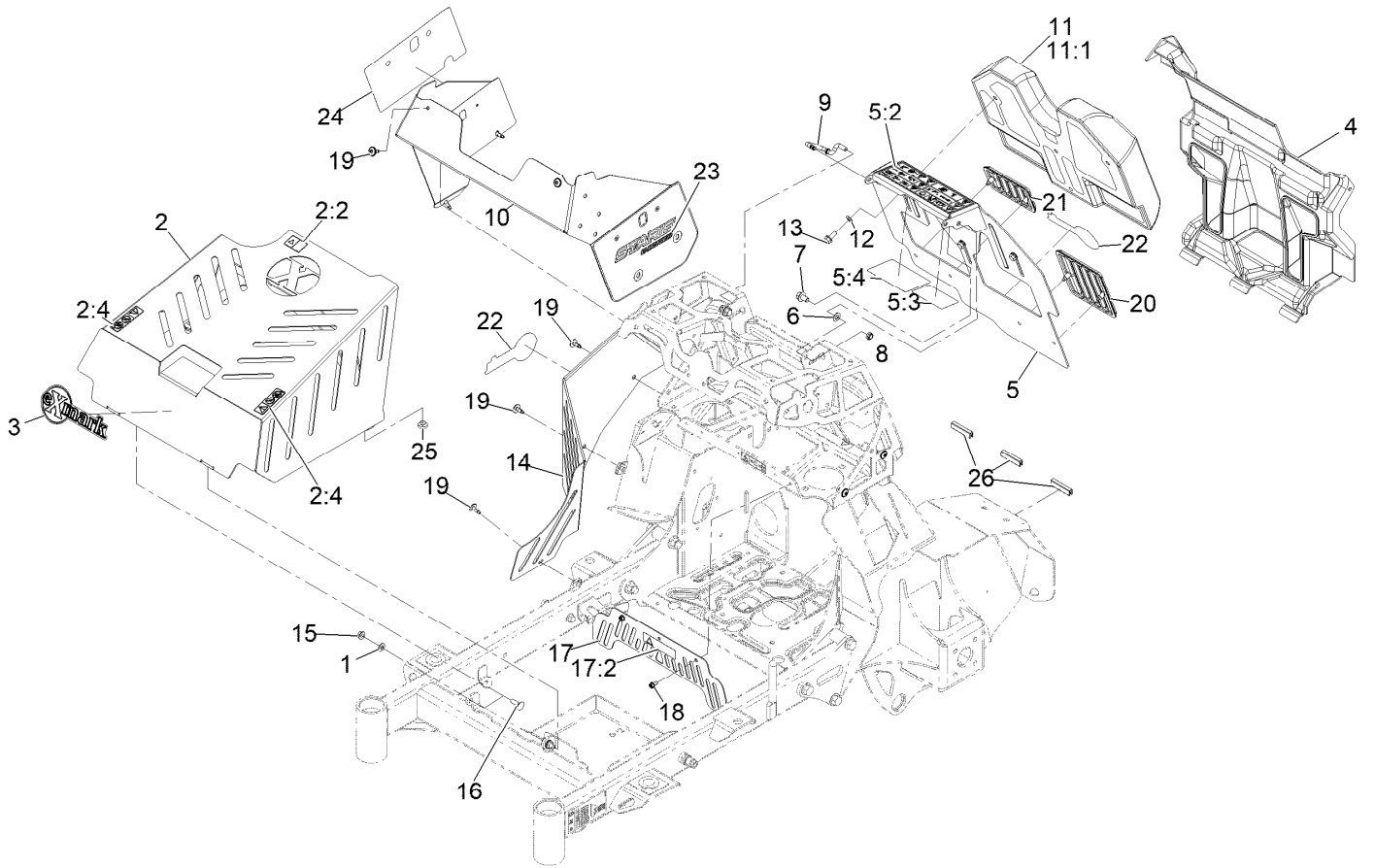

Guarding Assembly (continued)

<i>Ref.</i>	<i>Part Number</i>	<i>Qty.</i>	<i>Description</i>	<i>Ref.</i>	<i>Part Number</i>	<i>Qty.</i>	<i>Description</i>
1	93-6079	2	Spacer-Nylon	12	3290-475	3	Washer-Belleville
2	135-2190	1	ASM-Cover W Decals	13	100-1668	3	Screw-HHF
2:2	106-5517	1	Decal-Warning	14	142-3397-03	1	Cover, Rt Side
2:4	136-1672	2	Decal-No Step/Riders	15	32128-25	2	Nut-Hex 5/16-18 Side Lock
3	126-6877	1	Decal, Exmark Logo	16	3230-2	2	Bolt-Carriage 5/16-18 X 1
4	142-3523	1	Cover-Rear Ste	17	135-2204	1	ASM, Belt Guard W/ Decal
5	135-2601	1	ASM, Pad Backing W/ Decals	17:2	98-1977	1	Decal-Warning
5:2	135-2412	1	Decal-Warning	18	32104-17	2	Screw-HWH 1/4-20 X 1/2 Tap
5:3	116-8253	1	Decal-Drive Release	19	135-3494	9	Screw, Torx
5:4	135-2563	1	Decal-Service Aid Sm	20	135-5344	1	Pad, Knee, Lt
6	131-8667	2	Washer-Thrust	21	135-5345	1	Pad, Knee, Rt
7	3234-9	2	Screw-HHF	22	126-6575	2	Decal-Exmark Logo
8	3296-59	2	Nut-Nyloc 3/8-16 Thin	23	135-6807	1	Decal-Staris Logo Lt
9	135-1611	1	Rod, Prop	24	142-3088	1	Decal-Staris Logo Rt
10	142-2596-03	1	Skin, Tower	25	1-513658	2	Bumper
11	135-1972	1	Pad-Thigh	26	142-4759	3	Strip-Seal 2.13
11:1	135-6557	1	Cover, Pad				

Caster Wheel Assembly

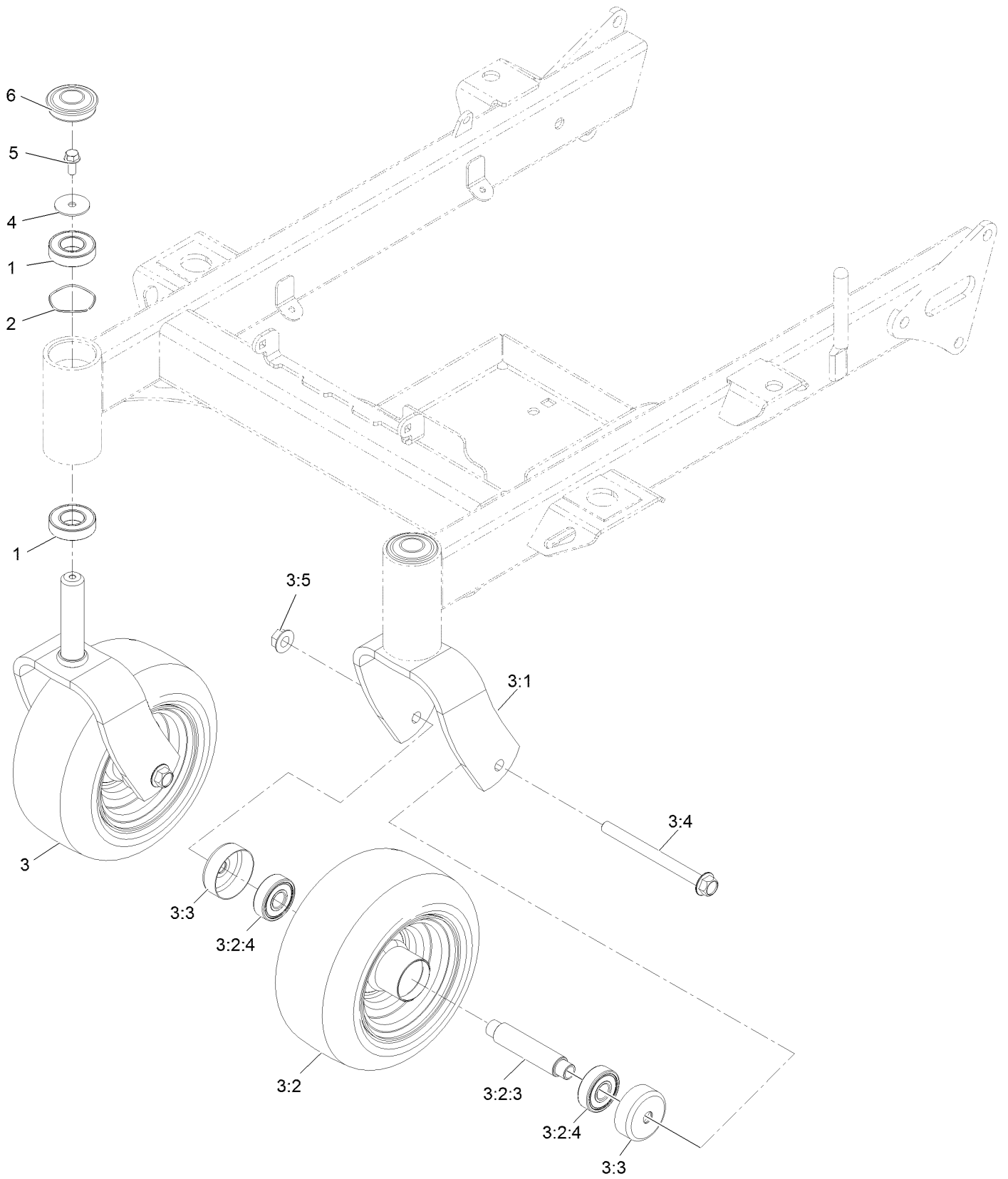

Caster Wheel Assembly (continued)

<i>Ref.</i>	<i>Part Number</i>	<i>Qty.</i>	<i>Description</i>	<i>Ref.</i>	<i>Part Number</i>	<i>Qty.</i>	<i>Description</i>
1	109-3678	4	Bearing-Ball	3:3	135-3218	2	Guard, Seal
2	126-5897	2	Spring	3:4	135-4633	1	Screw-HHF
3		2	ASM-Caster Fork W/Tire ●	3:5	32128-23	1	Nut-HF
3:1	135-1651-01	1	ASM-Caster Fork [red]	4	3256-68	2	Washer-Flat
3:2	135-4518	1	ASM-Tire&whl Sp 9X4.50-5	5	3234-5	2	Screw-HHF
3:2:3	126-7904	1	Axle-Caster	6	116-4348	2	Cap-Grease
3:2:4	116-4004	2	Bearing				

● Not serviced separately

Deck Lift Assembly

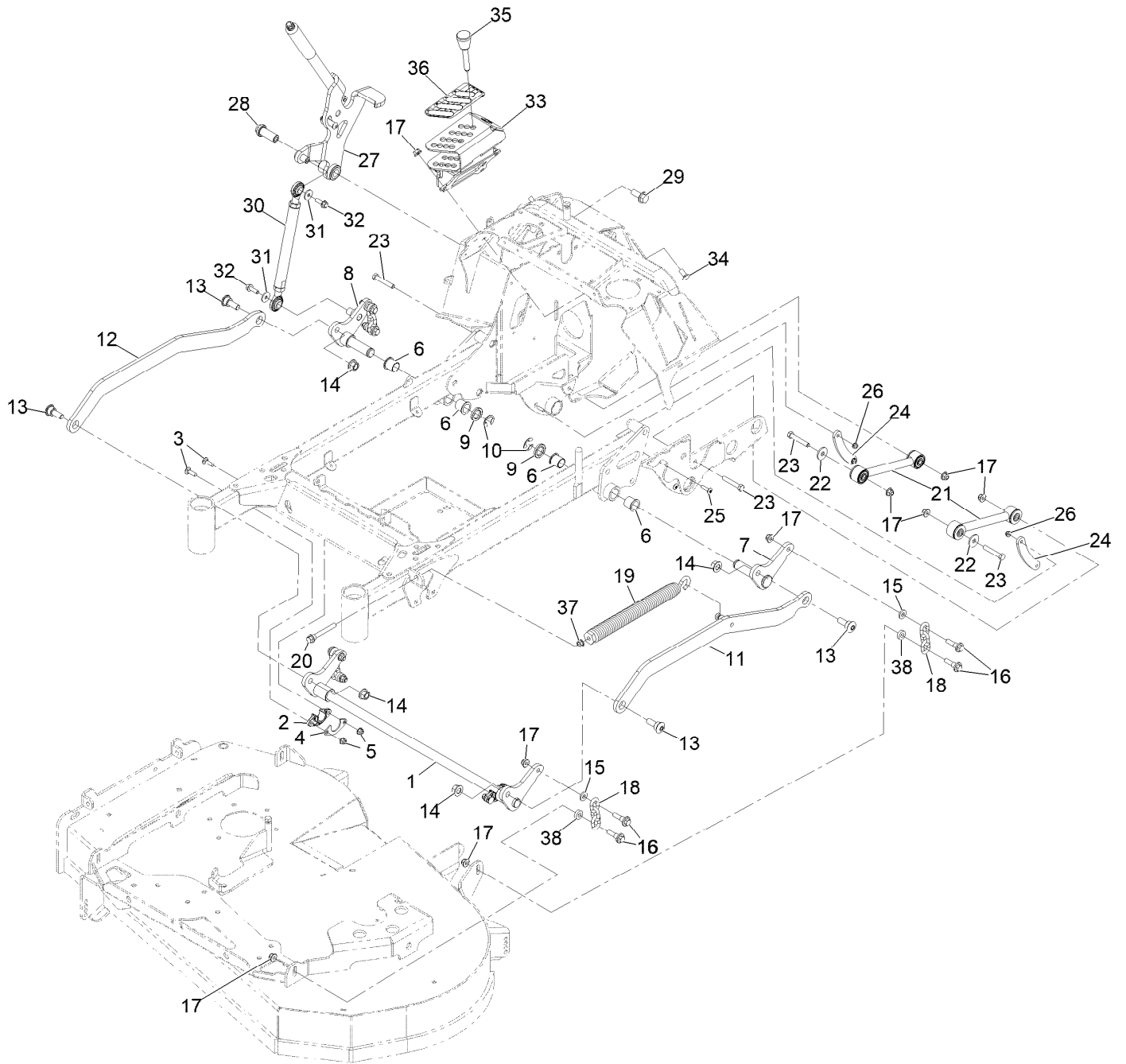

Deck Lift Assembly (continued)

<i>Ref.</i>	<i>Part Number</i>	<i>Qty.</i>	<i>Description</i>	<i>Ref.</i>	<i>Part Number</i>	<i>Qty.</i>	<i>Description</i>
1	142-2566-03	1	Weld, HOC Lift Shaft	20	92-7674	1	Screw-SHCS 3/8-16 X 2.212
2	115-5065	2	Bushing-Flange	21	142-2588	2	ASM, Strut W/ Bushings
3	3230-2	4	Bolt-Carriage 5/16-18 X 1	22	2844	2	Washer
4	116-2887	2	Gusset-Lift, Deck	23	104-3396	4	Screw-HH
5	104-8300	4	Nut-Nyloc 5/16-18 Flg	24	142-2772	2	Strip, Rub
6	135-1248	4	Bushing, Igus	25	32105-32	4	Screw-Truss HD 1/4-20 X 1
7	142-4524-03	1	Weld, Bellcrank, Lt Rr	26	104-7201	4	Nut-Nyloc 1/4-20 Flg
8	142-2570-03	1	Weld, Bellcrank, Rt Rr	27	142-2579	1	ASM, HOC Lever
9	142-3444	2	Spacer, HOC Pivot	28	142-2181	1	Pivot, HOC Lever
10	32151-103	2	E-Ring	29	3234-38	1	Screw-HHF 1/2-13 X 1 1/4
11	142-4521-03	1	Weld, Lift Strap, Lt	30	142-2581	1	ASM, Lift Rod
12	142-4522-03	1	Strap, Lift Rt	31	1-603716	2	Washer-Friction Disc
13	135-1259	4	Bolt, Shoulder	32	115-5142	2	Screw-HHF
14	99-5107	4	Nut-Lock 1/2-13	33	142-2585-03	1	Weld, HOC Index
15	43-0940	4	Spacer	34	3231-27	3	Bolt-Carriage 3/8-16 X 7/8
16	130-0742	8	Bolt-Shoulder	35	126-5401	1	Pin-HOC
17	104-8301	15	Nut-Nyloc 3/8-16 Flg	36	142-3087	1	Decal-Height Of Cut
18	103-9859	4	Chain-Decklift	37	3290-357	1	Nut-HHF, Whiz
19	116-0886	1	Spring-Extension	38	5-0652	4	Spacer

Height of Cut Lever

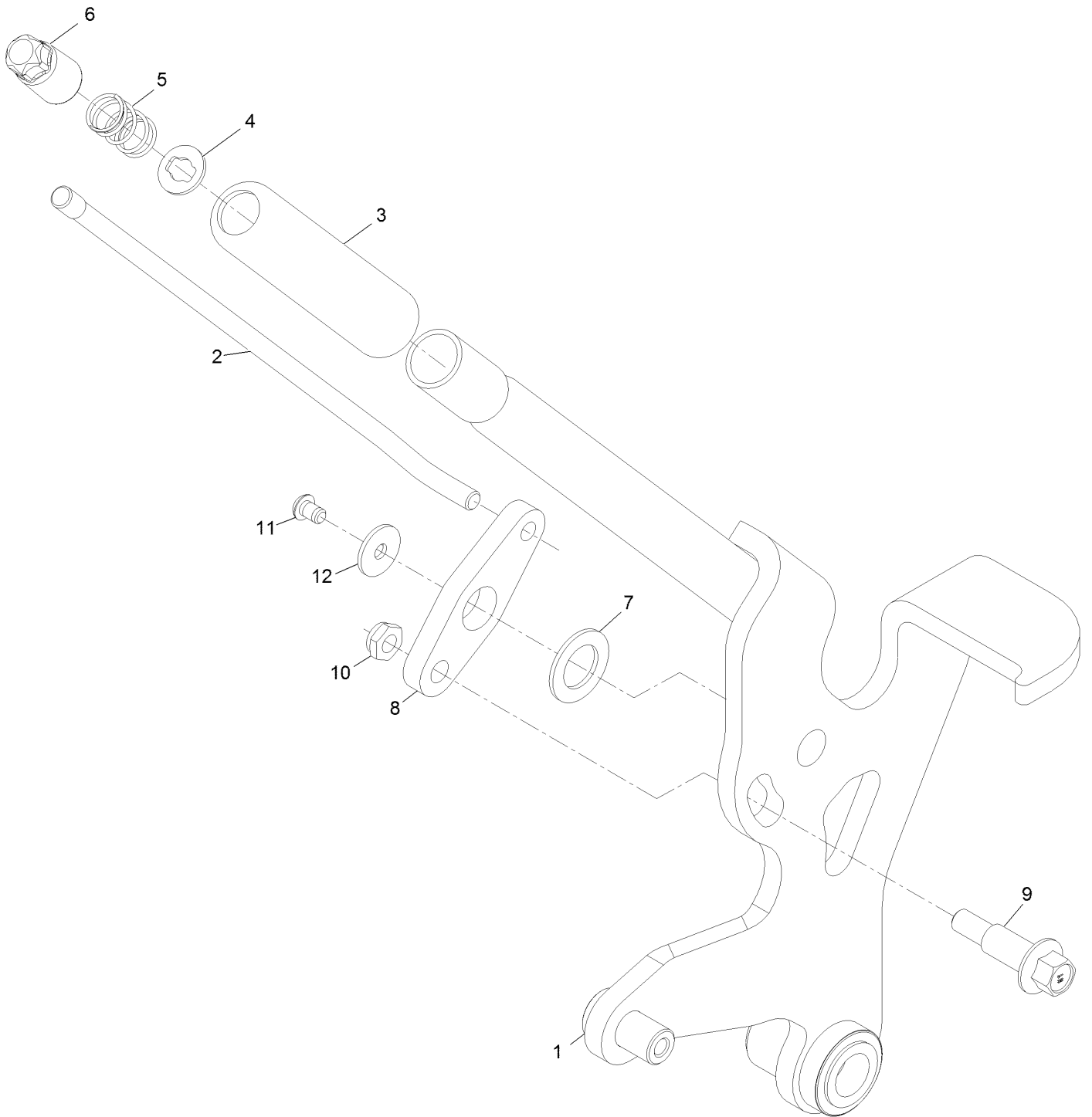

Height of Cut Lever (continued)

<i>Ref.</i>	<i>Part Number</i>	<i>Qty.</i>	<i>Description</i>	<i>Ref.</i>	<i>Part Number</i>	<i>Qty.</i>	<i>Description</i>
1	142-2577	1	ASM, Lever W/ Bushings	7	126-7888	1	Washer-Nylon
2	142-3358	1	Linkage, HOC Lever	8	142-2578	1	Arm, Transport
3	115-3592	1	Grip	9	142-4197	1	Screw-Bh
4	114-1207	1	Washer-Special	10	3296-59	1	Nut-Nyloc 3/8-16 Thin
5	114-8187	1	Spring-Compression	11	142-2216	1	Screw, 1/4-20 X 3/8 PH Torx
6	135-7809	1	Button, Push	12	3256-67	1	Washer

Lift Rod Assembly

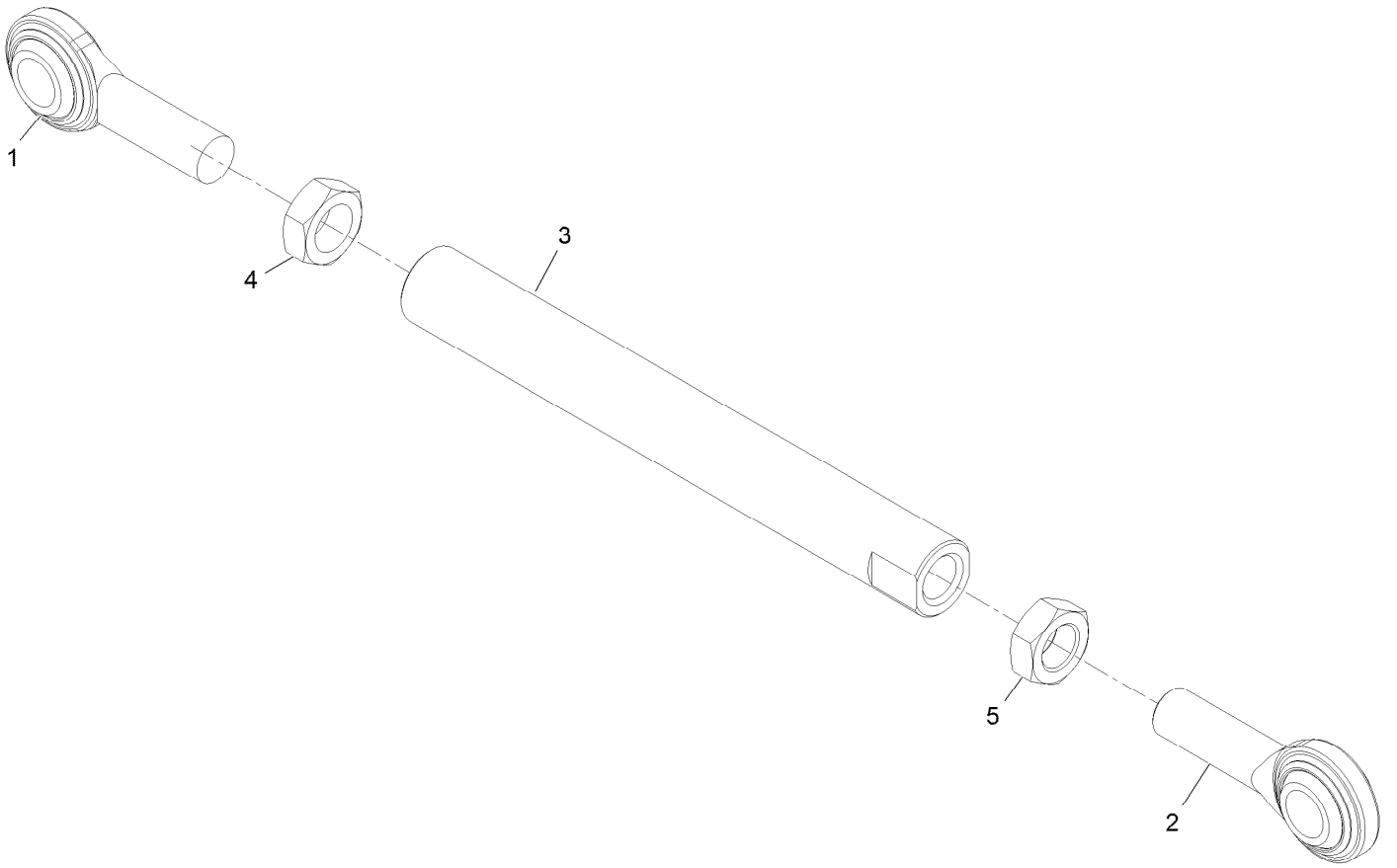

Lift Rod Assembly (continued)

<i>Ref.</i>	<i>Part Number</i>	<i>Qty.</i>	<i>Description</i>	<i>Ref.</i>	<i>Part Number</i>	<i>Qty.</i>	<i>Description</i>
1	1-633029	1	Balljoint	4	3220-6	1	Nut-Jam
2	117-5291	1	Balljoint-Spherical	5	117-5293	1	Nut-Jam
3	142-2580	1	Rod, Lift				

Park Brake Assembly

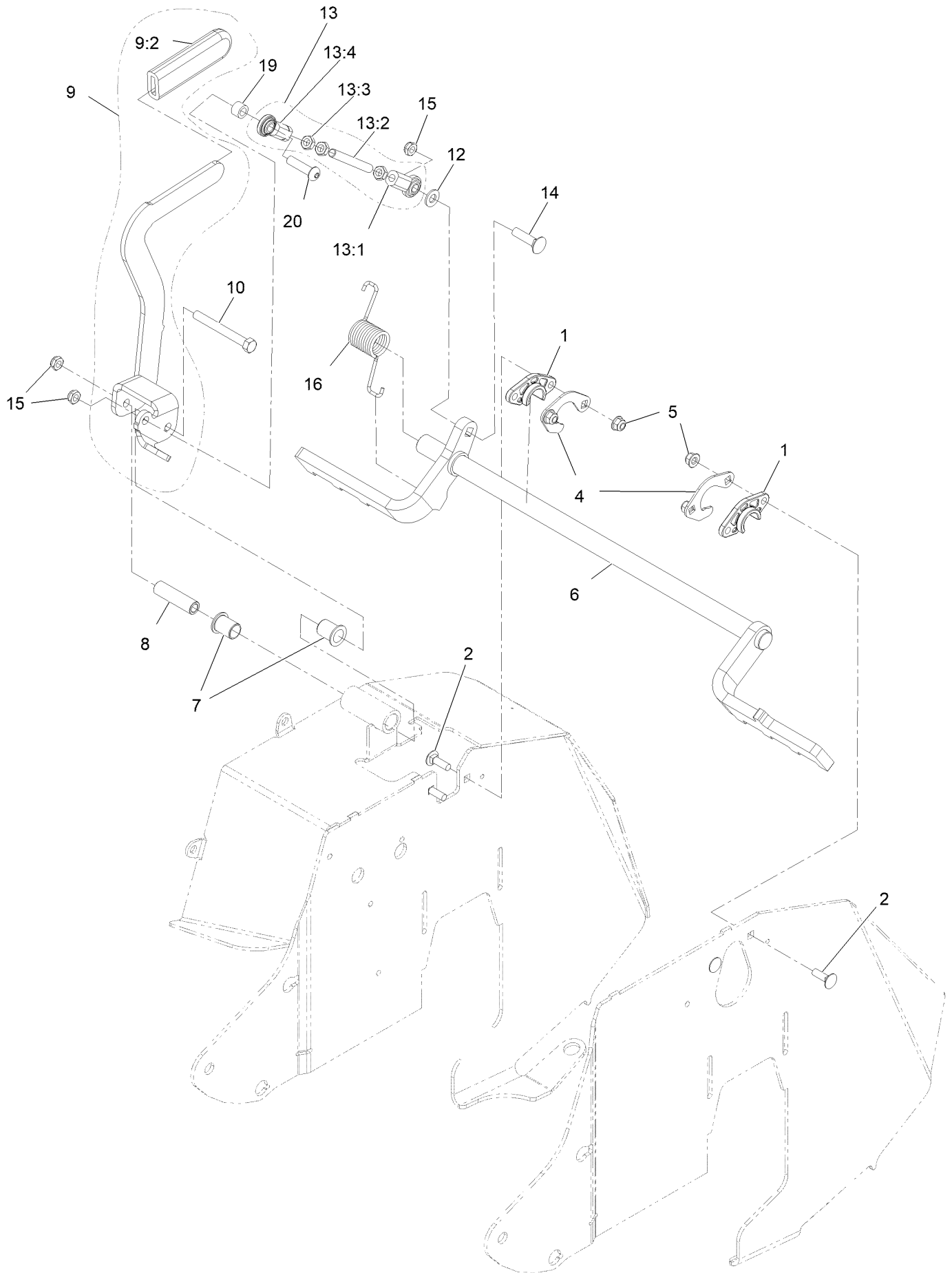

Park Brake Assembly (continued)

<i>Ref.</i>	<i>Part Number</i>	<i>Qty.</i>	<i>Description</i>	<i>Ref.</i>	<i>Part Number</i>	<i>Qty.</i>	<i>Description</i>
1	115-5065	2	Bushing-Flange	13	142-2562	1	ASM, Brake Link
2	3230-2	4	Bolt-Carriage 5/16-18 X 1	13:1	103-0608	1	Balljoint
4	135-7867	2	Support, Bearing	13:2	142-4034	1	Linkage, Brake
5	104-8300	4	Nut-Nyloc 5/16-18 Flg	13:3	3220-3	3	Nut-Jam 3/8-24
6	135-1950-03	1	Wld-Brake Shaft 32/36	13:4	103-1167	1	Joint-Ball End
7	138-2573	2	Bushing-Flange	14	3231-4	1	Bolt-Carriage 3/8-16 X 1 1/2
8	142-2558	1	Spacer, Brake Pivot	15	3296-59	3	Nut-Nyloc 3/8-16 Thin
9	142-2560	1	ASM, Lever W/ Grip	16	108-4052	1	Spring-Torsion
9:2	1-633268	1	Grip-Lever	19	142-4035	1	Spacer
10	112-7161	1	Screw-HH	20	95-3857	1	Screw-HSBH
12	3256-24	1	Washer-3/8 SAE				

Tire and Wheel Assembly

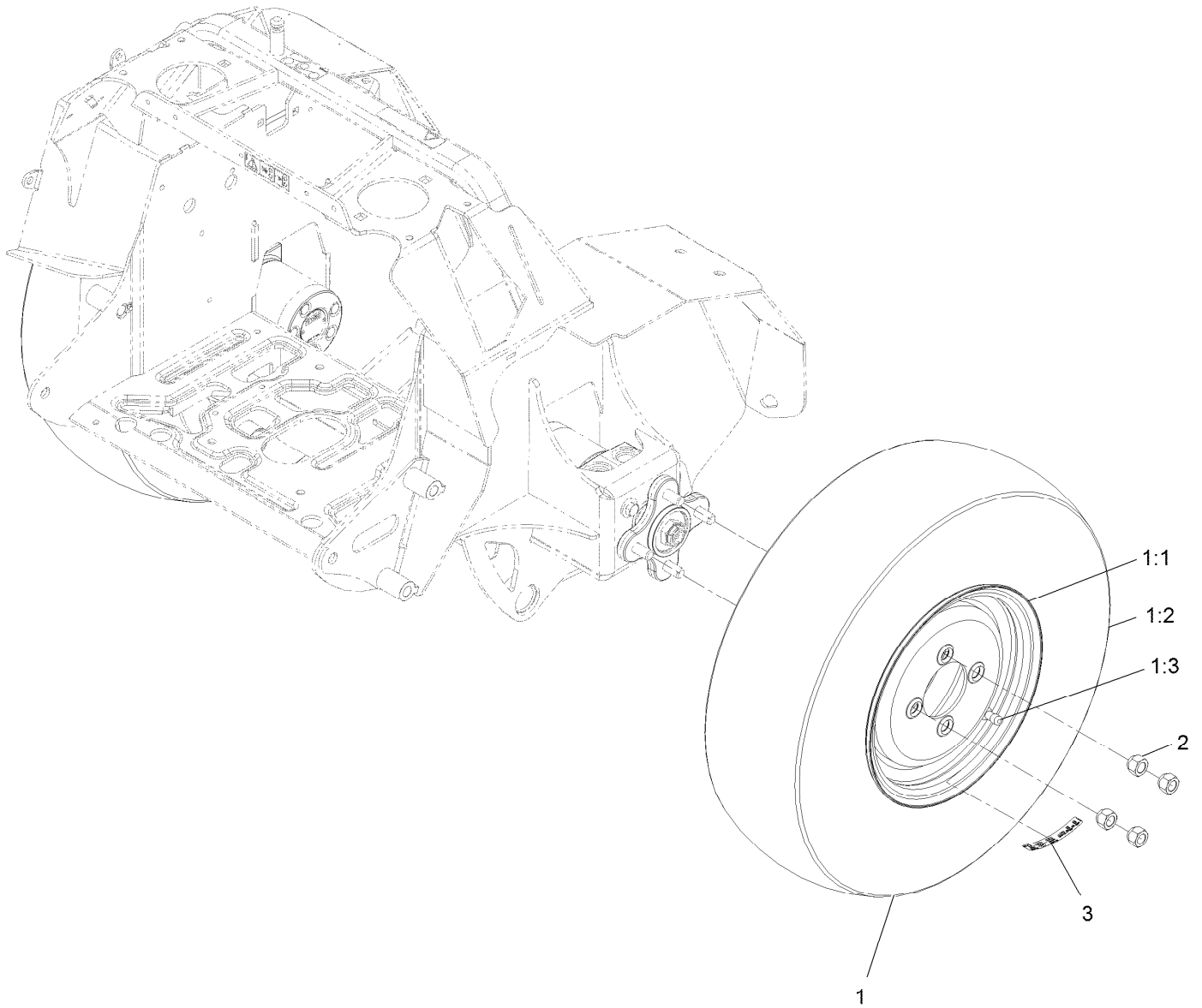

Tire and Wheel Assembly (continued)

<i>Ref.</i>	<i>Part Number</i>	<i>Qty.</i>	<i>Description</i>	<i>Ref.</i>	<i>Part Number</i>	<i>Qty.</i>	<i>Description</i>
1	135-1622	2	ASM-Whl Tire [+2.25 Os]	2	242-50	8	Nut-Lug
1:1	135-1624	1	Wheel 10 X 5.5 Wht	3	126-2056	2	Decal-Torque Wheel Lug-Hub
1:2	135-1623	1	Tire 21X7.00-10				
1:3	232-27	1	Stem-Valve				

Fuel Assembly

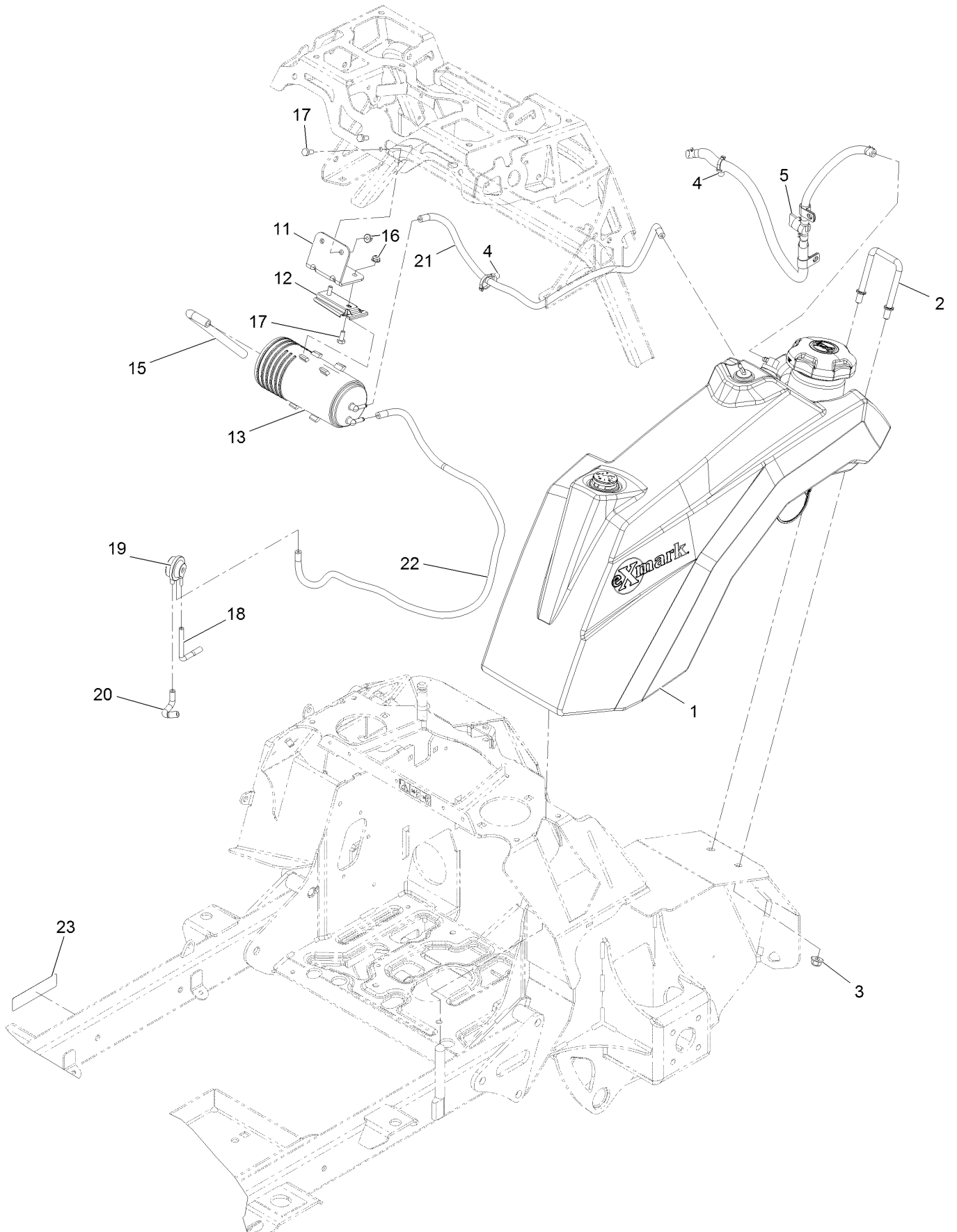

Fuel Assembly (continued)

<i>Ref.</i>	<i>Part Number</i>	<i>Qty.</i>	<i>Description</i>	<i>Ref.</i>	<i>Part Number</i>	<i>Qty.</i>	<i>Description</i>
1	135-1919	1	Assembly, Fuel Tank	16	104-7201	4	Nut-Nyloc 1/4-20 Flg
2	135-1921	1	Clamp, Tank	17	321-3	4	Screw-HH 1/4-20 X 5/8
3	104-8301	2	Nut-Nyloc 3/8-16 Flg	18	119-8501	1	Hose-Vent, Formed
4	32180-030	2	Clip-Tie	19	116-2232	1	Valve-Control, Vacuum
5	142-3596	1	ASM-Fuel Line & Valve	20	119-8502	1	Hose-Vent, Formed
11	135-4495-03	1	Bracket-Carbon Canister	21	119-6074	1	Hose-Fuel
12	114-0292	1	Bracket-Canister, Carbon	22	132-6854	1	Hose-Fuel
13	117-1221	1	Canister-Carbon, 800Cc	23	133-8062	1	Decal-Arrestor, Spark
15	115-0962	1	Hose-Vent, Canister				

Fuel Tank Assembly-cont.

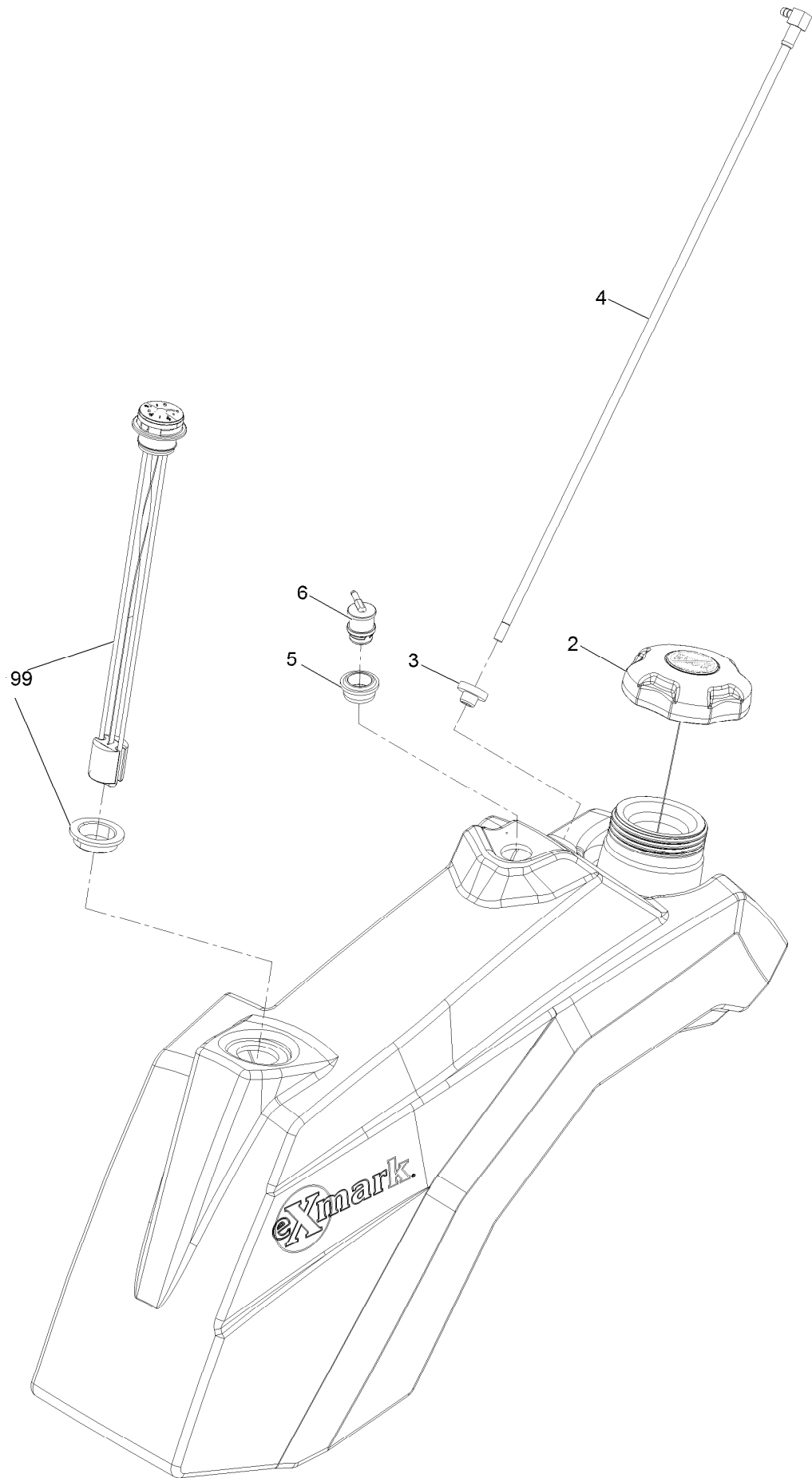

Fuel Tank Assembly-cont. (continued)

<i>Ref.</i>	<i>Part Number</i>	<i>Qty.</i>	<i>Description</i>	<i>Ref.</i>	<i>Part Number</i>	<i>Qty.</i>	<i>Description</i>
2	137-4119	1	Cap-Fuel, Ratcheting	6	119-3547	1	Valve-Vent, Fuel
3	46-6560	1	Bushing	99	135-3694	1	Kit-Fuel Gauge Replacement
4	135-1917	1	Straw, Fuel, Long				
5	114-0284	1	Grommet				

Fuel Line and Valve Assembly

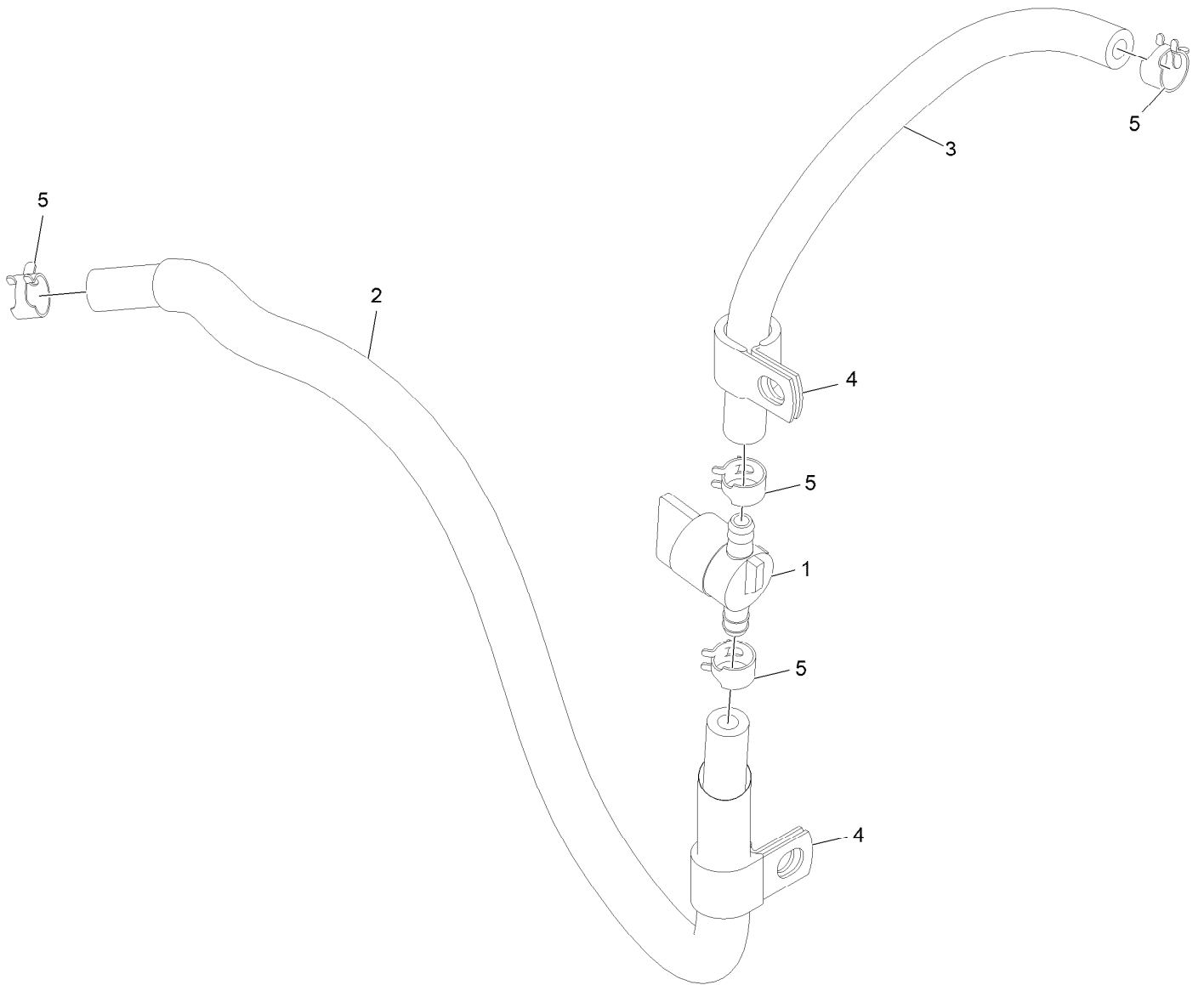

Fuel Line and Valve Assembly (continued)

<i>Ref.</i>	<i>Part Number</i>	<i>Qty.</i>	<i>Description</i>	<i>Ref.</i>	<i>Part Number</i>	<i>Qty.</i>	<i>Description</i>
1	1-603770	1	Valve-Fuel	4	92-6064	2	Clamp-R
2	109-0298	1	Line-Fuel	5	2412-98	4	Clamp-Hose
3	109-0293	1	Hose-Fuel				

Engine Assembly

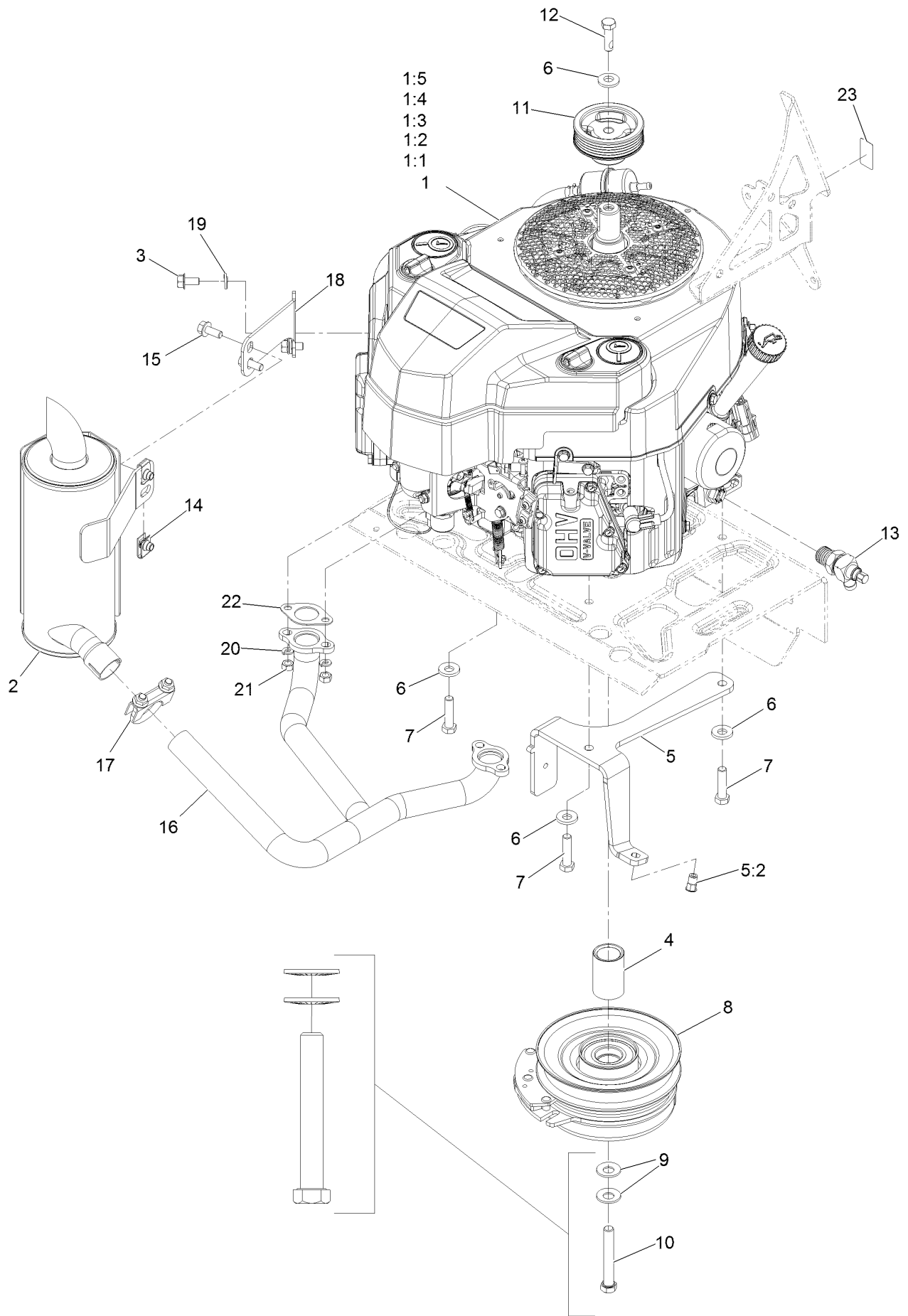

Engine Assembly (continued)

<i>Ref.</i>	<i>Part Number</i>	<i>Qty.</i>	<i>Description</i>	<i>Ref.</i>	<i>Part Number</i>	<i>Qty.</i>	<i>Description</i>
1		1	Engine-Kawasaki Fs600 ■▲	7	323-8	4	Screw-HH 3/8-16 X 1 1/2
1:1		1	Kawasaki 49065-7007 Engine Oil Filter ■▲	8	142-3586	1	Clutch 105
1:2		1	Kawasaki 49019-0031 Fuel Filter ■▲	9	1-603610	2	Washer-Spring Disc 7/16
1:3		1	Kawasaki 92070-7004 Plug-Spark Bpr4ES ■▲	10	126-7198	1	Screw-HH 7/16-20 X 3 W/Loctite ◆
1:4		1	Kawasaki 11013-7046 Foam Pre-Filter ■▲	11	135-1198	1	Pulley, Crank
1:5		1	Kawasaki 11013-0752 Air Filter ■▲	12	135-7890	1	Screw-HH, Patch,
2	135-5025	1	Muffler-Vertical Ka	13	135-2660	1	Drain-Oil Valve ●
3	33104-016	2	Screw-HHF	14	94-2413	2	Nut-U
4	135-5028	1	Spacer-Clutch	15	3234-5	2	Screw-HH Flg 5/16-18 X 3/4
5	135-6711	1	ASM-Clutch Anchor W/Insert	16	135-5026	1	Manifold-Vertical Ka Exh
5:2	138-2758	1	Nut-Clinch,Hex	17	104-4090	1	Clamp-Muffler
6	98-5975	5	Washer-Spring Disc 3/8	18	135-3828-03	1	Bracket-Muffler Vertical
				19	3253-21	2	Washer-Lock 3/8
				20	114-3550	4	Washer-Spring Lock M8
				21	114-3549	4	Nut-M8
				22	1-653313	2	Gasket-Exhaust
				23	135-6844	1	Decal-10W-50 Oil

● Torque to 23-29 ft-lb

▲ Obtain parts from www.kawpower.com

◆ Use Pro-Lock, Nut Type (P/N 1-840022, .5ml tube) on threads.

■ Not serviced separately

Hydraulic Assembly

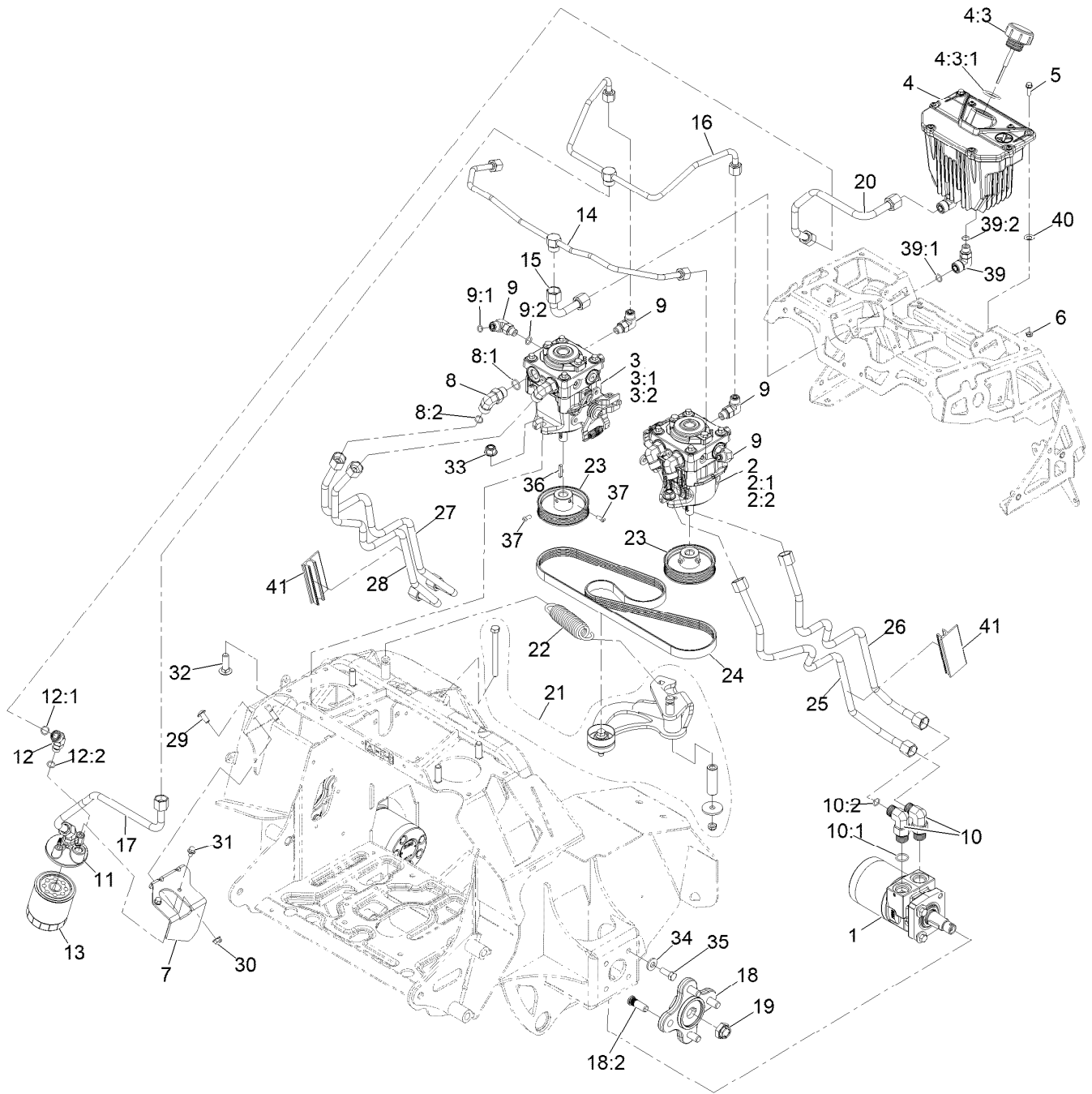

Hydraulic Assembly (continued)

<i>Ref.</i>	<i>Part Number</i>	<i>Qty.</i>	<i>Description</i>	<i>Ref.</i>	<i>Part Number</i>	<i>Qty.</i>	<i>Description</i>
1	135-1274	2	Motor-Wheel	19	116-2839	2	Nut-Lock
2	135-2212	1	Pump-Hydraulic 10Cc	20	142-2593	1	Line, HYD. Supply
2:1	126-2479	1	Kit, 10Cc/12Cc Pump Kit	21	135-1270	1	ASM, Idler Arm
2:2	105-6184	1	Seal Overhaul Kit	22	135-1272	1	Spring, Extension
3	135-2211	1	Pump-Hydraulic 10Cc	23	142-2968	2	Pulley, Pvk5
3:1	126-2479	1	Kit, 10Cc/12Cc Pump Kit	24	135-1196	1	Belt, Pvk5
3:2	105-6184	1	Seal Overhaul Kit	25	142-5632	1	Kit-Ste HYD Line Lt Rear B-A
4	135-3305	1	ASM, Hydraulic Reservoir	26	142-5633	1	Kit-Ste HYD Line Lt Frnt A-B
4:3	142-2793	1	Cap, Hydraulic	27	142-5634	1	Kit-Ste HYD Line Rt Rear B-B
4:3:1	142-2792	1	O-Ring	28	142-5635	1	Kit-Ste HYD Line Rt Frnt A-A
5	32105-15	2	Screw-Machine 1/4-20 X 3/4	29	126-6268	2	Screw-Truss HD 5/16-18 X 3/4 Torx Plus
6	3296-56	2	Nut-Nyloc 1/4-20 Thin	30	104-8300	2	Nut-Nyloc 5/16-18 Flg
7	142-2592-03	1	Mount, Filter	31	3234-13	2	Screw-HH Flg 1/4-20 X 1/2
8	340-98	4	Fitting-Elbow, 90 DEG	32	3232-3	4	Bolt-Carriage 7/16-14 X 1 1/2
8:1	237-79	1	O-Ring	33	114-8417	4	Nut-HF, NI
8:2	237-30	1	O-Ring	34	98-5975	8	Washer-Spring Disc 3/8
9	340-77	4	Fitting-Elbow, 90 DEG	35	323-6	8	Screw-HH 3/8-16 X 1
9:1	237-22	1	O-Ring	36	135-7971	2	Key, 5Mm X 5Mm X 29Mm
9:2	237-42	1	O-Ring	37	3241-7	4	Screw-SQH 1/4-20 X 1/2 ■
10	340-105	4	Fitting-Elbow, 90 DEG	39	340-99	2	Fitting-HYD, 90 DEG
10:1	237-80	1	O-Ring	39:1	237-30	1	O-Ring
10:2	237-30	1	O-Ring	39:2	237-42	1	O-Ring
11	103-2888	1	Head-Filter	40	73-0041	2	Washer-Thrust
12	340-96	2	Adapter	41	142-4399	2	Spacer-Hydraulic Tube
12:1	237-30	1	O-Ring	99	105-6184	1	Seal Overhaul Kit ●
12:2	237-42	1	O-Ring	99	126-2479	1	Kit, 10Cc/12Cc Pump Kit ●
13	109-4180	1	Element, Oil Filter	99	133-1779	1	Seal Kit ●
14	135-7056	1	Line, Hydraulic, Case Tee				
15	135-7054	1	Line, Hydraulic, Case				
16	135-7055	1	Line, Hydraulic, Charge Tee				
17	142-2594	1	Line, HYD. Charge				
18	135-1621	2	ASM-Hub And Studs				
18:2	116-1696	4	Stud-Wheel				

● Not illustrated

■ Use Pro-Lock, Nut Type (P/N 1-840022, .5ml tube) on threads.

Idler Arm Assembly

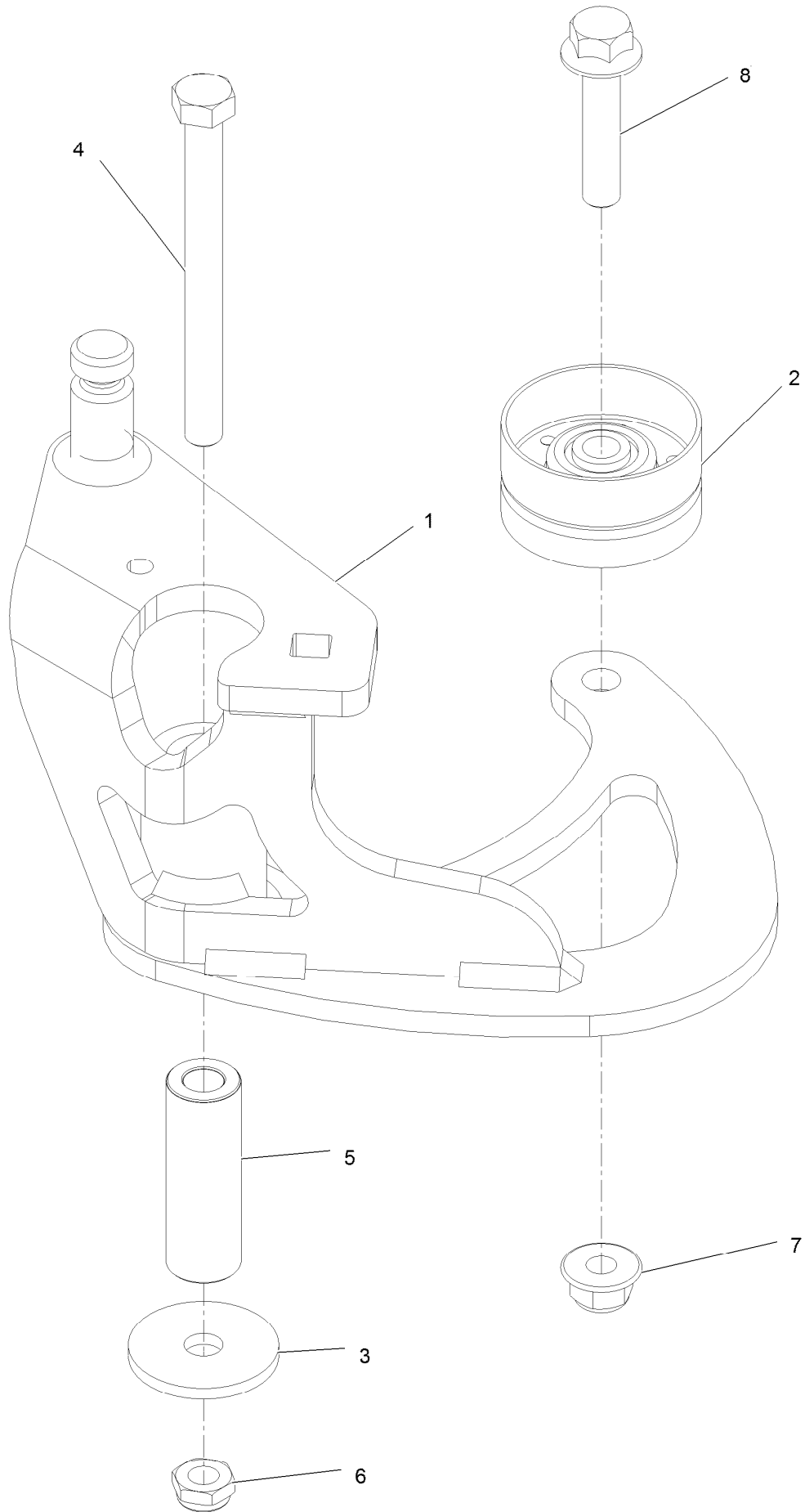

Idler Arm Assembly (continued)

<i>Ref.</i>	<i>Part Number</i>	<i>Qty.</i>	<i>Description</i>	<i>Ref.</i>	<i>Part Number</i>	<i>Qty.</i>	<i>Description</i>
1	135-2238	1	ASM, Idler Arm W/ Bushings	5	135-1273	1	Tube, Idler Pivot
2	135-1199	1	Idler, Flat	6	3296-59	1	Nut-Nyloc 3/8-16 Thin
3	1-213069	1	Washer	7	104-8301	2	Nut-Nyloc 3/8-16 Flg
4	323-16	1	Screw-HH 3/8-16 X 4	8	3234-19	1	Screw-HHF 3/8-16 X 1 3/4

Electrical Assembly

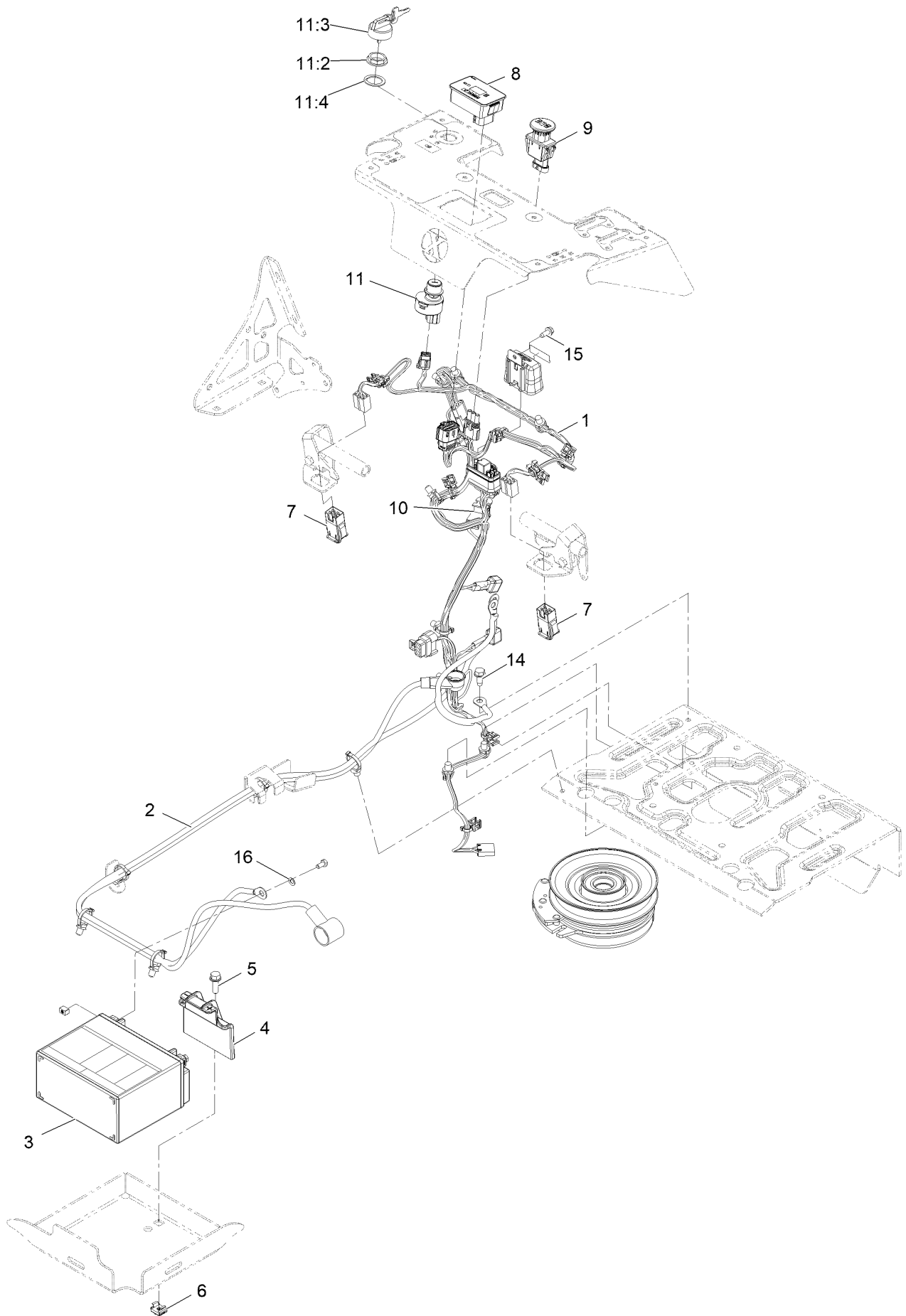

Electrical Assembly (continued)

<i>Ref.</i>	<i>Part Number</i>	<i>Qty.</i>	<i>Description</i>	<i>Ref.</i>	<i>Part Number</i>	<i>Qty.</i>	<i>Description</i>
1	142-2926	1	Harness-Wiring ■	11	126-6285	1	Ignition Switch ASM
2	135-2255	1	Harness-Battery	11:2	108-8660	1	Nut-Mounting
3	142-7427	1	Battery-Agm	11:3	106-5270	1	Ignition Key Set
4	135-4422	1	Hold Down, Battery	11:4	108-8659	1	Washer-Backup
5	3234-29	1	Screw-HH Flg 5/16-18 X 1	14	32144-11	1	Screw-HWH 5/16-18 X 3/4 Tf
6	135-4473	1	Nut, Snap	15	32144-10	1	Screw-HWH 1/4-20 X .62
7	104-3338	2	Switch-Delta	16	1-303435	2	Washer-Spring Disc 1/4
8	135-7189	1	Module-Hour Meter	99	142-7682	1	Hardware Kit, Battery ●
9	126-6187	1	Switch-PTO, Sealed				
10	82-2190	1	Switch				

● Not illustrated

■ Use dielectric grease on all unsealed connectors and terminals only. Do not apply in sealed connectors.

Harness Assembly

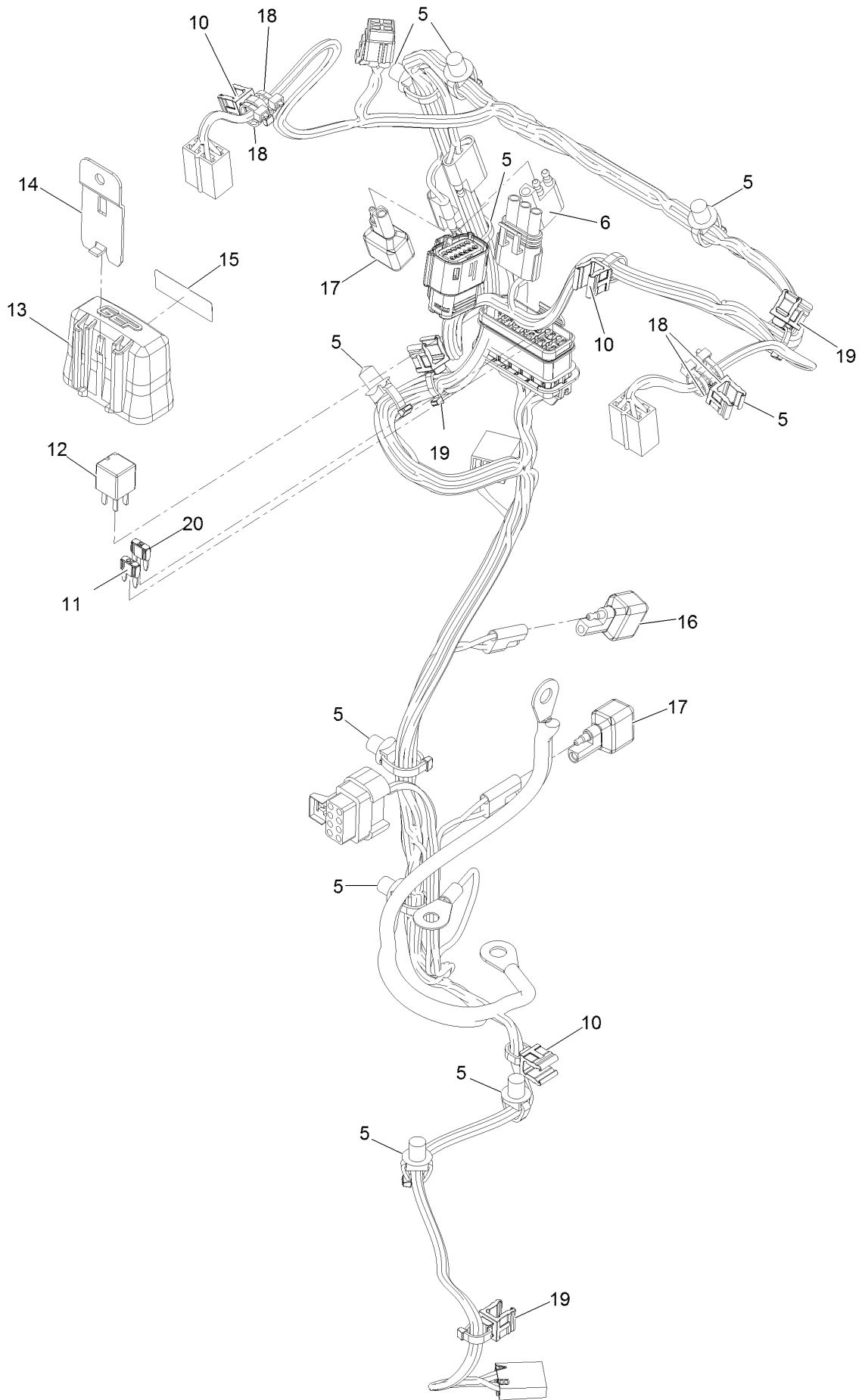

Harness Assembly (continued)

<i>Ref.</i>	<i>Part Number</i>	<i>Qty.</i>	<i>Description</i>	<i>Ref.</i>	<i>Part Number</i>	<i>Qty.</i>	<i>Description</i>
5	32180-030	9	Clip-Tie	15	126-7875	1	Decal-Fuse
6	32180-197	1	Cap-Plug	16	103-3895	1	Diode
10	32180-078	4	Clip-Edge	17	100-4918	2	Diode
11	121-8868	1	Fuse-Mini Blade, 20 Amp	18	1-303287	7	Tie-Cable
12	126-3991	1	Relay-Micro	19	32180-082	3	Clip-Edge W/Tie, Perpendicular
13	32180-176	1	Cover-Block, Fuse	20	121-8867	1	Fuse-Mini Blade, 15 Amp
14	32180-177	1	Clip-Mounting				

Notes:



MAXIMIZE THE PERFORMANCE OF YOUR EXMARK MACHINE.



EXMARK® PREMIUM ENGINE OIL

Exmark now offers a family of engine oil viscosities to perform well in any environment. Each viscosity has the same synthetic formulation to give you what you need in punishing conditions. We designed each grade to the highest quality, making it ideal even for diesel applications. Coupled with Exmark Premium Fuel Treatment, we have the performance products to make your machine hum.

EXMARK PREMIUM ENGINE OIL SAE 30/10W-30

- Meets zero shear requirements of a straight grade SAE 30 as well as the cold temp properties of a 10W-30.
- Most versatile oil in the industry.
- Superior corrosion protection over conventional oil - even in corrosive, humid environments.

EXMARK PREMIUM ENGINE OIL SAE 20W-50

- Perfect for your big block engine, or any application in severe service.
- Same full synthetic formulation as all other Exmark Premium viscosities.
- Also effective for use in severe service small block engines.

EXMARK PREMIUM ENGINE OIL SAE 10W-50

- Full synthetic formulation gives you peak performance. Don't settle for less.
- Wide span multi-grade combines easy starting in cold weather with maximum protection in high temperature operation.
- Reduce friction & wear over standard mineral formulations.

EXMARK PREMIUM ENGINE OIL SAE 0W-40

- The perfect choice for when the weather turns cold or unpredictable, and your Exmark UTV has to perform.
- Commercial quality for severe service.
- Advanced additive package helps prevent corrosion from long-term storage.

EXMARK PREMIUM ENGINE OIL UTV FORMULATION

- 4-cycle high-temp formulation.
- Heavier viscosity, full synthetic, perfect for your UTV.

EXMARK PREMIUM UTV EXTREME CONDITIONS GEAR OIL

- SAE 80W-90, designed to keep your UTV performing at its peak.
- Shear stable, hypoid gear lube.
- Includes a premium additive system to combat wear, oxidation, rust & corrosion.

Available from your local Exmark dealer. Find your closest dealer at exmark.com

EXMARK ACCESSORIES AND OPTIONS*

MID-MOUNT RIDING ACCESSORIES AND OPTIONS

CUSTOM RIDE SEAT SUSPENSION SYSTEM	OPERATOR CONTROLLED DISCHARGE
FULL SUSPENSION SEAT	SUN SHADE
DECK LIFT ASSIST KIT	TRASH CONTAINER
HITCH KIT	TURF STRIPER
LIGHT KIT	ULTRA VAC COLLECTION SYSTEM
12V POWER PORT	ULTRA VAC QUICK DISPOSAL SYSTEM
MICRO-MULCH SYSTEM	

OUT-FRONT RIDING ACCESSORIES AND OPTIONS

CUSTOM RIDE SEAT SUSPENSION SYSTEM	SNOW BLADE
DUAL-TAIL WHEEL	SNOWBLOWER
FLOOR PAN EXTENDER	SUN SHADE
HITCH KIT	TRASH CONTAINER
LIGHT KIT	ULTRA VAC COLLECTION SYSTEM
MICRO-MULCH SYSTEM	ULTRA VAC QUICK DISPOSAL SYSTEM
ROLL OVER PROTECTION SYSTEM (ROPS)	WEATHER CAB

WALK-BEHIND ACCESSORIES AND OPTIONS

GRASS CATCHER	TURF STRIPER
MICRO-MULCH SYSTEM	STANDON

*Some accessories and options not available for some models.

Place Model No. and Serial No.
Label Here (Included in the Literature
Pack) or Fill in Below

Model No. _____

Serial No. _____

Date Purchased _____

Engine Model No. and Spec. No. _____

Engine Serial No. (E/No) _____

© 2021 Exmark Mfg. Co., Inc.
415 Industrial Row
Beatrice, NE 68310
All Rights Reserved

Part No. 4505-665 Rev. A
(402) 223-6375
Fax (402) 223-5489
Printed in the USA.

