

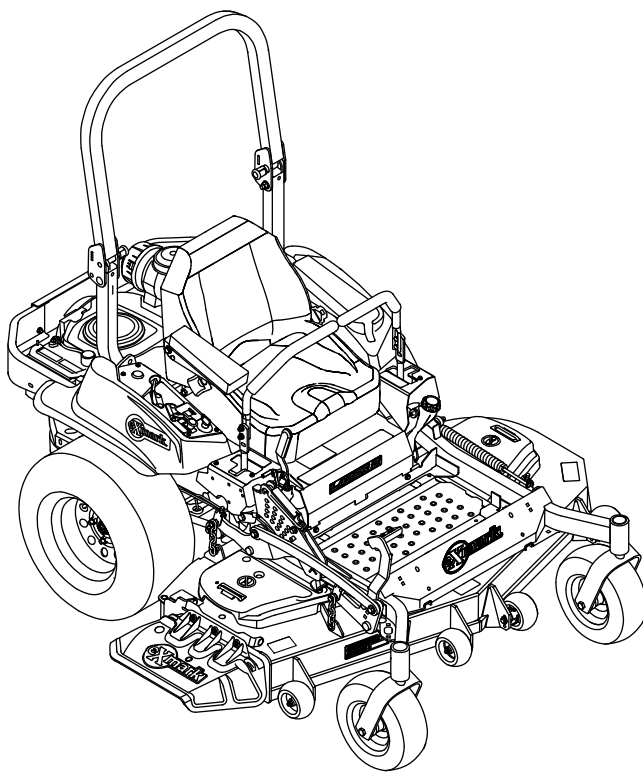

LAZER E-SERIES

Model No. LZE801GKA724A1—Serial No. 408644346 and Up

Picture below may not reflect actual product.



Parts Manual

Part No. 4505-441 Rev. A

Ordering Replacement Parts

To order replacement parts, please supply the part number, the quantity, and the description of each part desired.

Understanding Reference Numbers

Each identified part in an illustration has a reference number. The reference number for a part also appears in the parts list, along with other information about the part.

This catalog uses two special reference number formats, one to indicate parts in a service assembly and another to indicate the quantity of a given part in an illustration.

Service Assembly Reference Numbers

Parts in service assemblies have reference numbers in the form a:b. The a represents the reference number of the entire service assembly and the b represents a sequential number unique to each part within the service assembly.

For example, a wheel assembly might be identified by reference number 6, the tire by 6:1, the valve by 6:2, and the wheel by 6:3. When you order the assembly identified by reference number 6, you receive all parts identified by reference numbers 6:1, 6:2, and 6:3. However, you may also order any part individually. Reference numbers of this type appear in illustration and in parts lists.

Reference Numbers Indicating Quantity

In an illustration, if a reference number indicates more than one part, the reference number has the form nX y. The n represents the quantity of the part, the X is the multiplication symbol, and the y represents the reference number.

For example, in an illustration, the reference number 2X 37 means that two of the parts identified by reference number 37 are indicated.

Touch Up Paint

Exmark black touch up spray paint – gloss black.

Exmark red touch up paint (spray paint – P/N 1-850337 - .6 oz liquid bottle – P/N 103-9140).



If your Exmark dealer does not have the Exmark part in stock, Exmark will get the parts to the dealer the next business day or the part will be FREE Guaranteed!! (Some restrictions apply. See your participating Exmark Dealer for details.)

Contents

Complete Deck Assembly	4
Deck Assembly	6
Deck W/Decals Assembly No. 116-1665	8
Idler Assembly	10
Main Frame Assembly	12
E-Series Decal	14
Roll-Over Protection System	16
Roll-Over Protection System Assembly	18
Front Caster and Fork Assembly	20
Caster Wheel and Fork Assembly	22
Deck Lift Assembly	24
Height-of-Cut Assembly No. 109-7438	26
Console Assembly	28
Motion Control Assembly	30
Rear Wheel Assembly	32
Park Brake Assembly	34
Seat Assembly	36
Seat Assembly (cont.)	38
Fuel System Assembly	40
Fuel Tank Assembly	42
Engine Assembly	44
Hydraulic Assembly	46
LH Hydro Assembly No. 135-7903	48
RH Hydro Assembly No. 135-7904	50
Pump Idler Assembly No. 116-1255	52
Electrical Assembly	54

Complete Deck Assembly

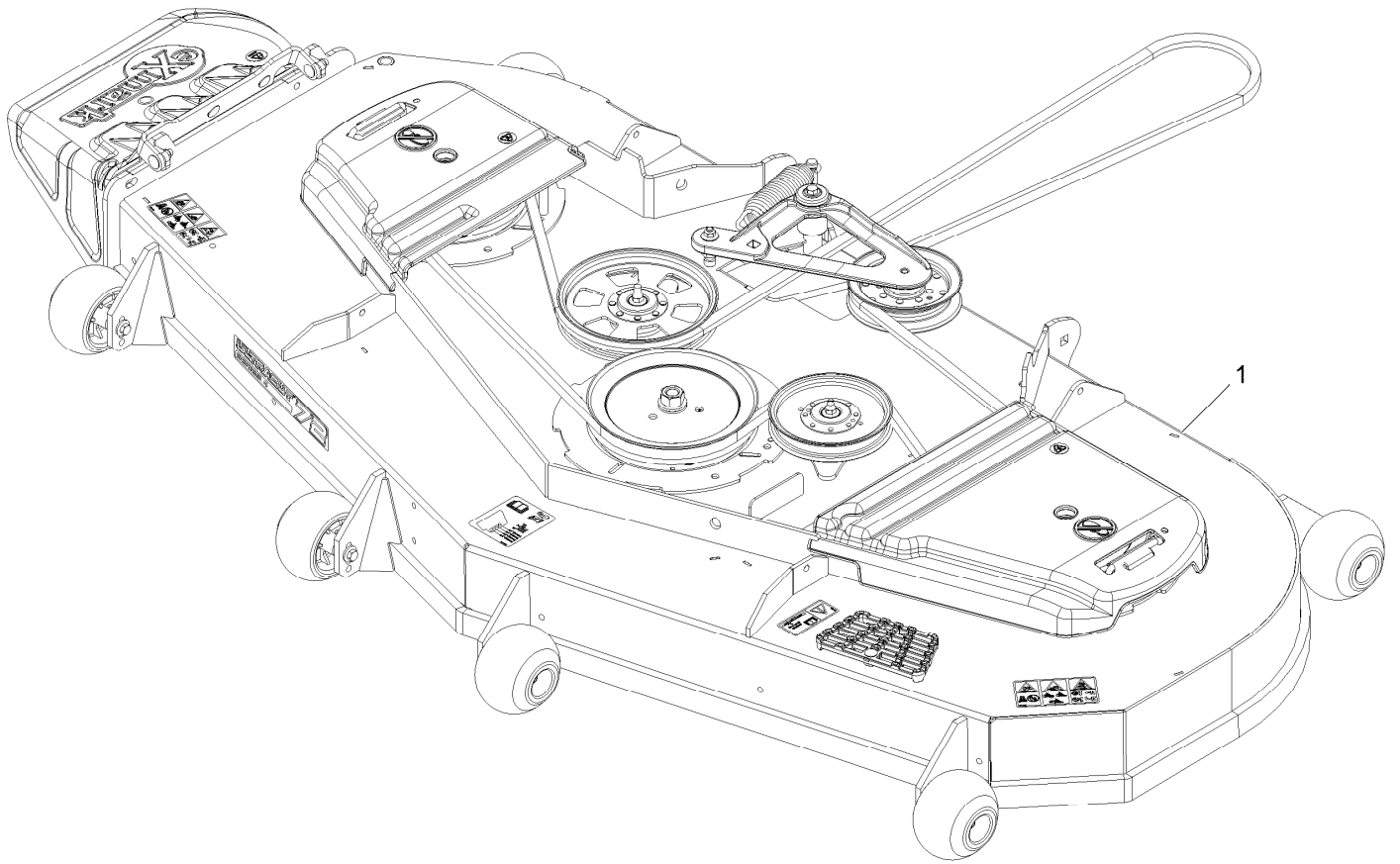

Complete Deck Assembly (continued)

<i>Ref.</i>	<i>Part Number</i>	<i>Qty.</i>	<i>Description</i>
1	116-3600	1	ASM,724 Deck Complete

Deck Assembly

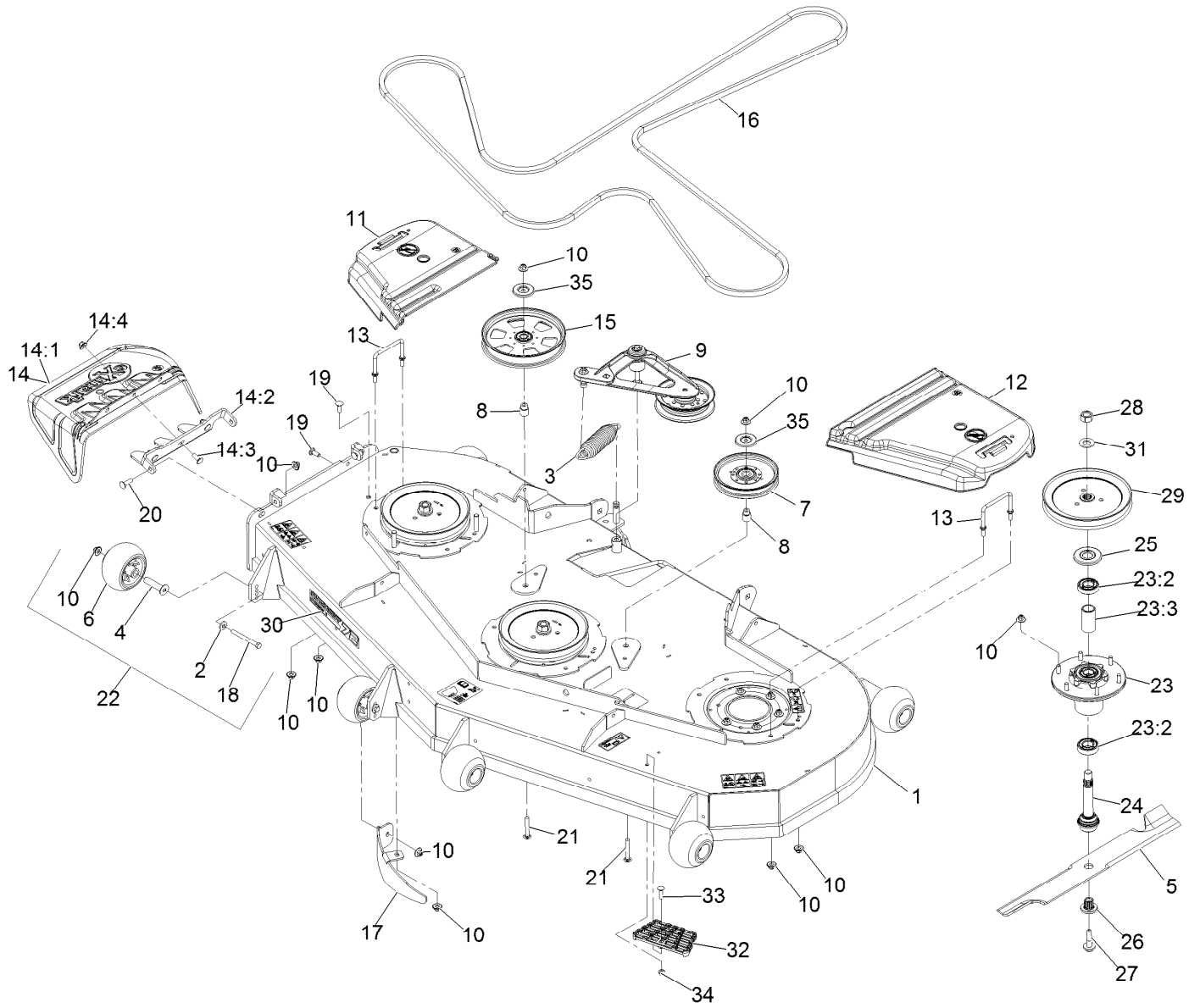

Deck Assembly (continued)

<i>Ref.</i>	<i>Part Number</i>	<i>Qty.</i>	<i>Description</i>	<i>Ref.</i>	<i>Part Number</i>	<i>Qty.</i>	<i>Description</i>
1	116-1665	1	ASM,Deck W/Decals 724	18	116-9362	6	Screw-HH 3/8-16 X 3 3/4 GR 8
2	98-5975	6	Washer-Spring Disc 3/8	19	3231-22	2	Bolt-Carriage 3/8-16 X 1
3	116-6317	1	Spring-Extension	20	3231-28	2	Bolt-Carriage 3/8-16 X 1 1/4
4	116-8131	6	Axle, Roller	21	3231-44	2	Bolt-Carriage 3/8-16 X 2 1/2
5	103-6384	3	Blade, Solid (72")	22	116-9981	6	Kit, Anti-Scalp Roller
5	103-6389	3	Blade, Low Lift (72")	23	116-3344	3	ASM-Cutter Hsg With Bearings
5	103-6394	3	Blade, Mulching ▲	23:2	116-0720	2	Bearing-Ball
5	103-6404	3	Blade, Notched (72")	23:3	116-3312	1	Spacer-Bearing
5	116-5171	3	Blade-Extreme 2, 24.50"	24	116-3341	3	ASM-Spindle And Seal ◆
6	103-8415	6	Roller-Anti-Scalp	25	116-1286	3	Guard,Bearing Top .989
7	126-7685	1	Idler-Pulley	26	103-3037	3	Bushing, Splined
8	1-633456	2	Bushing, Idler	27	109-9220	3	Screw-Sems 1/2-20 X 2.19 ● □
9	116-3755	1	Deck Idler ASM	28	116-7306	3	Nut-Hex ■
10	109-6658	34	Nut-Nyloc 3/8-16 Flg	29	116-1377	3	Sheave,Blade Drive 8.74
11	116-0094	1	Cover-Belt, RH	30	126-6590	1	Decal, 724
12	109-6938	1	Cover-Belt, LH	31	103-2802	3	Washer-Spring Disc 3/4
13	109-6982	2	Wireform-Cover	32	126-4781-03	1	Step-Deck
14	109-7188	1	ASM,Discharge Chute	33	3230-3	1	Bolt-Carriage 5/16-18 X 1 1/4
14:1	109-2738	1	Chute, Discharge	34	104-8300	1	Nut-Nyloc 5/16-18 Flg
14:2	109-8675-01	1	Bracket,Discharge Chute	35	126-8043	2	Shield-Dust
14:3	3231-22	3	Bolt-Carriage 3/8-16 X 1				
14:4	109-6658	3	Nut-Nyloc 3/8-16 Flg				
15	116-9639	1	Pulley-Idler, Flat				
16	135-5777	1	Belt-V				
17	116-5834-01	1	Baffle-Dogleg, Lz72				

● Torque to 50-60 ft-lb

■ Torque to 130-160 ft-lb

▲ Requires installation of mulch kit for proper mulching. See your Exmark dealer for details.

◆ Apply Mobil HTS grease (P/N 103-5217 1.5 oz packet) (or a food-grade anti-seize) to spindle shaft

□ Apply lubricant to threads as needed to prevent seizing. Copper based anti-seize preferable. Grease is an acceptable substitute.

Deck W/Decals Assembly No. 116-1665

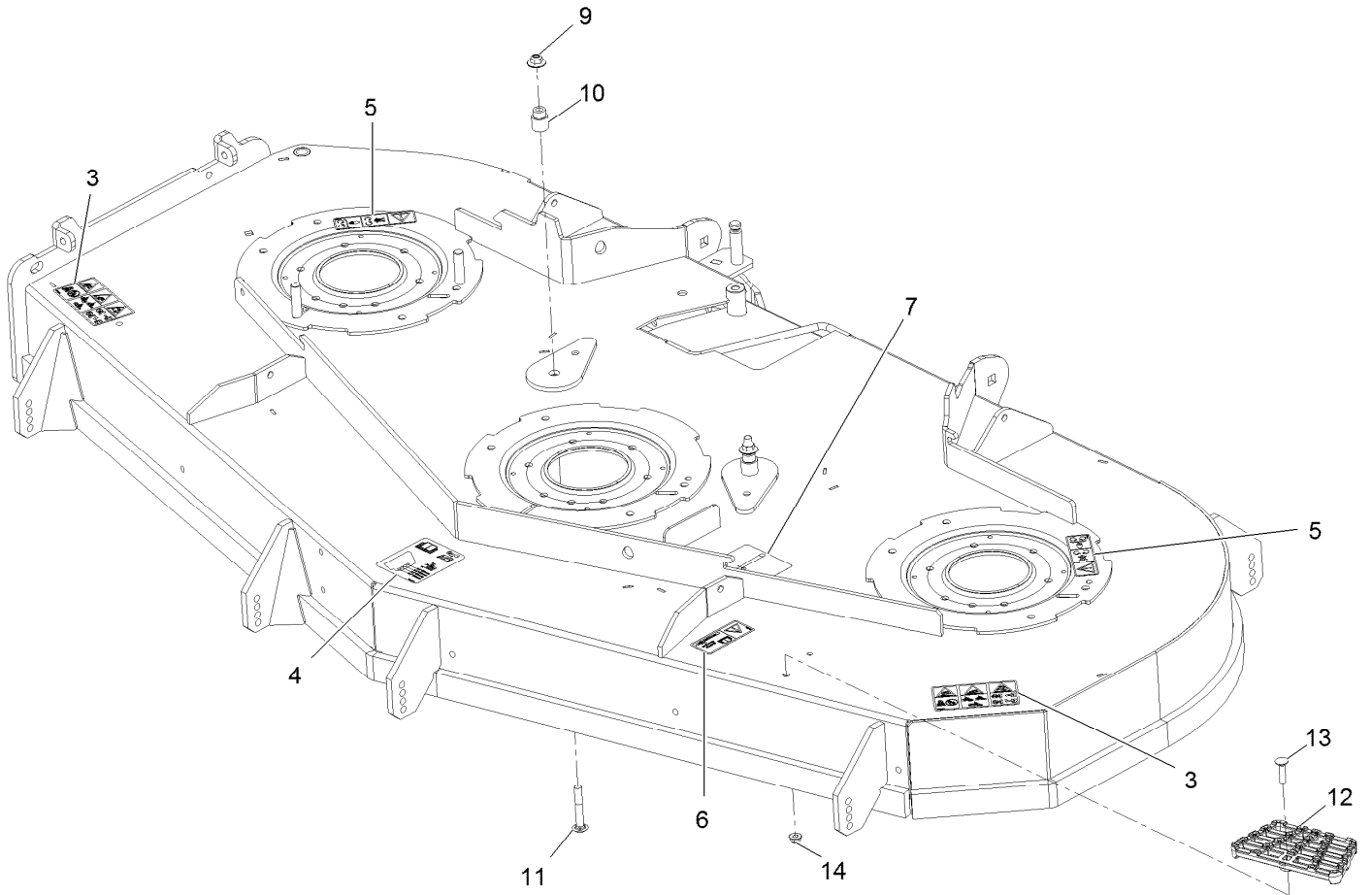

Deck W/Decals Assembly No. 116-1665 (continued)

<i>Ref.</i>	<i>Part Number</i>	<i>Qty.</i>	<i>Description</i>	<i>Ref.</i>	<i>Part Number</i>	<i>Qty.</i>	<i>Description</i>
3	126-6464	2	Decal-Danger Thrown Objects	9	109-6658	2	Nut-Flange, NI
4	109-6036	1	Decal-Roller, Anti-Scalp	10	1-633456	2	Bushing, Idler
5	112-9028	2	Decal-Cover, Missing	11	3231-44	2	Screw-CARR
6	116-8283	1	Decal-Torque, Bolt	12	126-4781-03	1	Step-Deck
7	116-8727	1	Decal-Belt Routing	13	3230-3	1	Screw-CARR
				14	104-8300	1	Nut-HF, NI

Idler Assembly



Idler Assembly (continued)

<i>Ref.</i>	<i>Part Number</i>	<i>Qty.</i>	<i>Description</i>	<i>Ref.</i>	<i>Part Number</i>	<i>Qty.</i>	<i>Description</i>
1	43-0940	1	Spacer	9	126-0423	1	Pin-Spring, Anchor
2	103-2916	1	Guard-Top	10	109-6658	2	Nut-Flange, NI
3	103-3504	2	Bearing-Spherical	11	109-7409	1	Screw-Shoulder, HH
4	103-3505	1	Seal-Lip, Double	12	323-8	1	Screw-HH
5	103-3506	1	Seal-Lip, Single	13	32120-10	2	Ring-Snap
6	126-9196	1	Idler-Pulley, Flat	14	302-19	1	Fitting-Grease
7	106-7159	2	O-Ring	15	126-9195	1	Shield-Guard, Dust

Main Frame Assembly

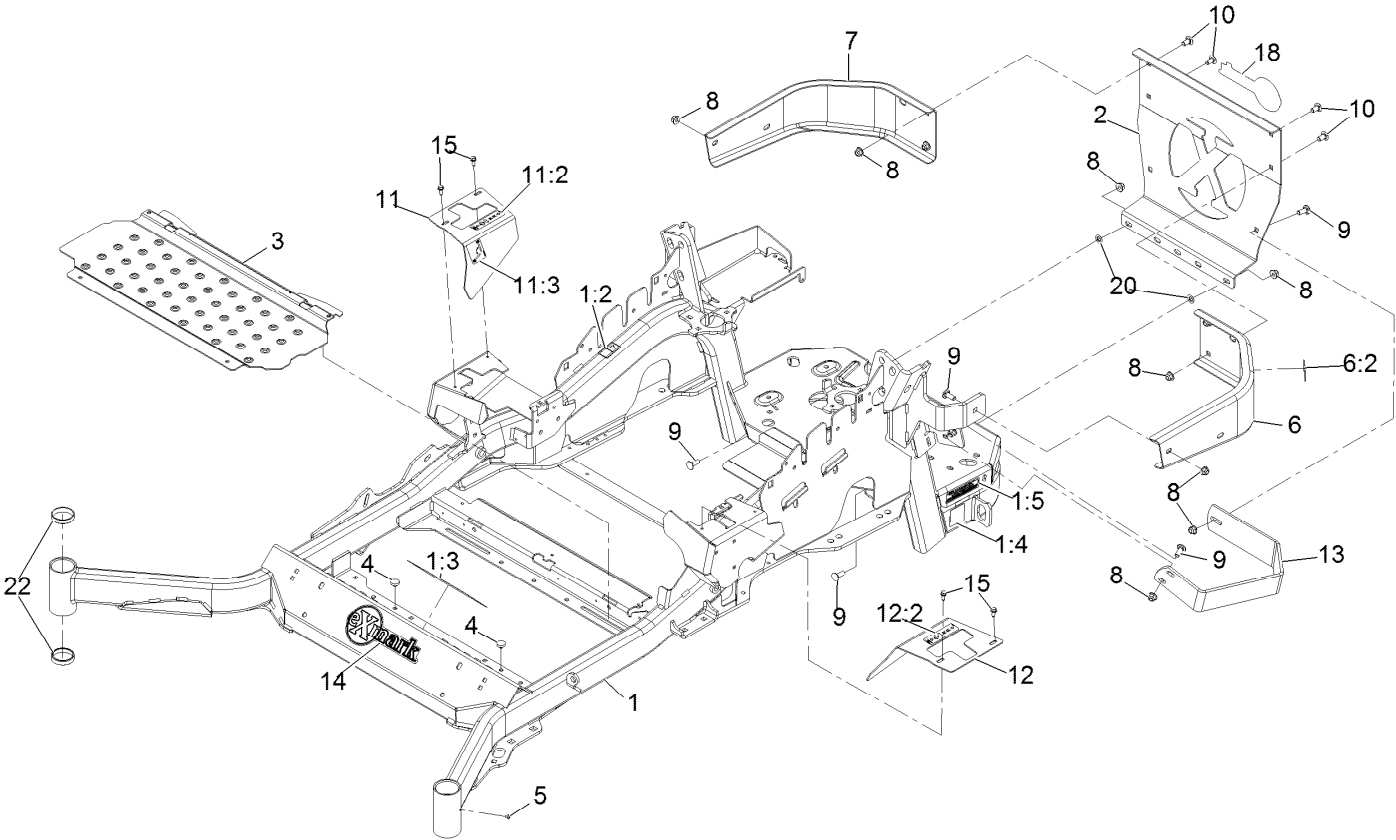

Main Frame Assembly (continued)

<i>Ref.</i>	<i>Part Number</i>	<i>Qty.</i>	<i>Description</i>	<i>Ref.</i>	<i>Part Number</i>	<i>Qty.</i>	<i>Description</i>
1	116-5904	1	Mainframe ASM	10	3231-21	4	Bolt-Carriage 3/8-16 X 3/4
1:2	106-5517	2	Decal-Warning	11	116-5899	1	RH Motion Control Cover ASM
1:3	132-0871	1	Decal-Danger	11:2	99-8936	1	Decal-Control, Motion
1:4	106-2655	2	Decal-Hazard, Pinched Finger	11:3	116-5988	1	Decal-Park Brake, CE
1:5	133-8062	1	Decal-Arrestor, Spark	12	116-0580	1	LH Motion Control Cover ASM
2	109-8863-03	1	Plate,Rear Guard	12:2	99-8936	1	Decal-Control, Motion
3	116-8898-01	1	Floorpan	13	126-2067-03	1	Guard-Muffler
4	1-513658	2	Bumper	14	135-2274	1	Decal-Exmark
5	1-811010	2	Plug	15	32144-10	4	Screw-HWH 1/4-20 X .62
6	116-0180	1	LH Bumper ASM	18	126-6877	1	Decal, Exmark Logo
6:2	106-5517	1	Decal-Warning	20	107-3154	2	Nut-Push 3/8-16
7	116-0057-03	1	Bumper-RH	22	1-543508	4	Cup-Bearing Tapered Roller
8	104-8301	11	Nut-Nyloc 3/8-16 Flg				
9	3231-22	7	Bolt-Carriage 3/8-16 X 1				

E-Series Decal

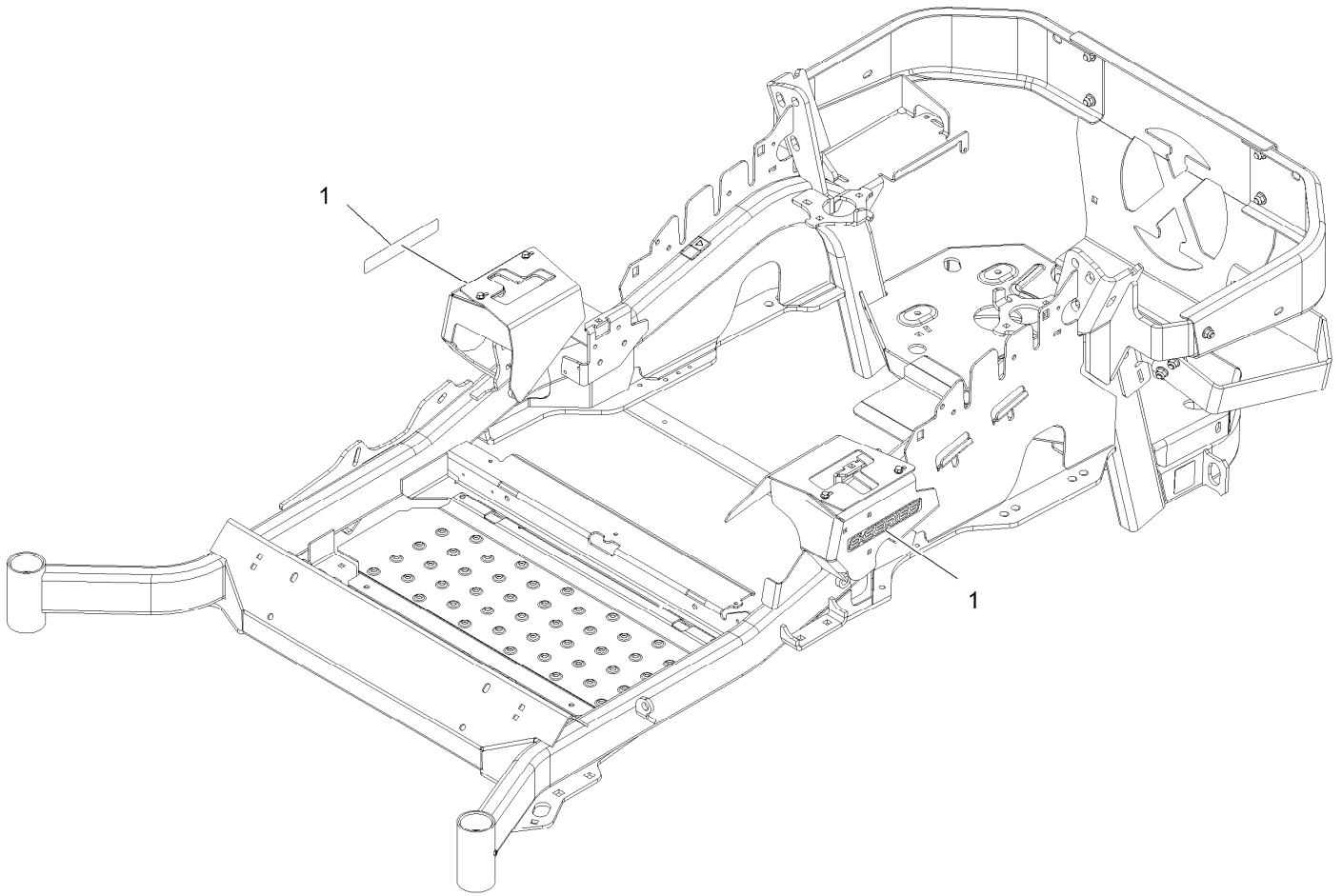

E-Series Decal (continued)

<i>Ref.</i>	<i>Part Number</i>	<i>Qty.</i>	<i>Description</i>
1	126-6571	2	Decal-E-Series

Roll-Over Protection System

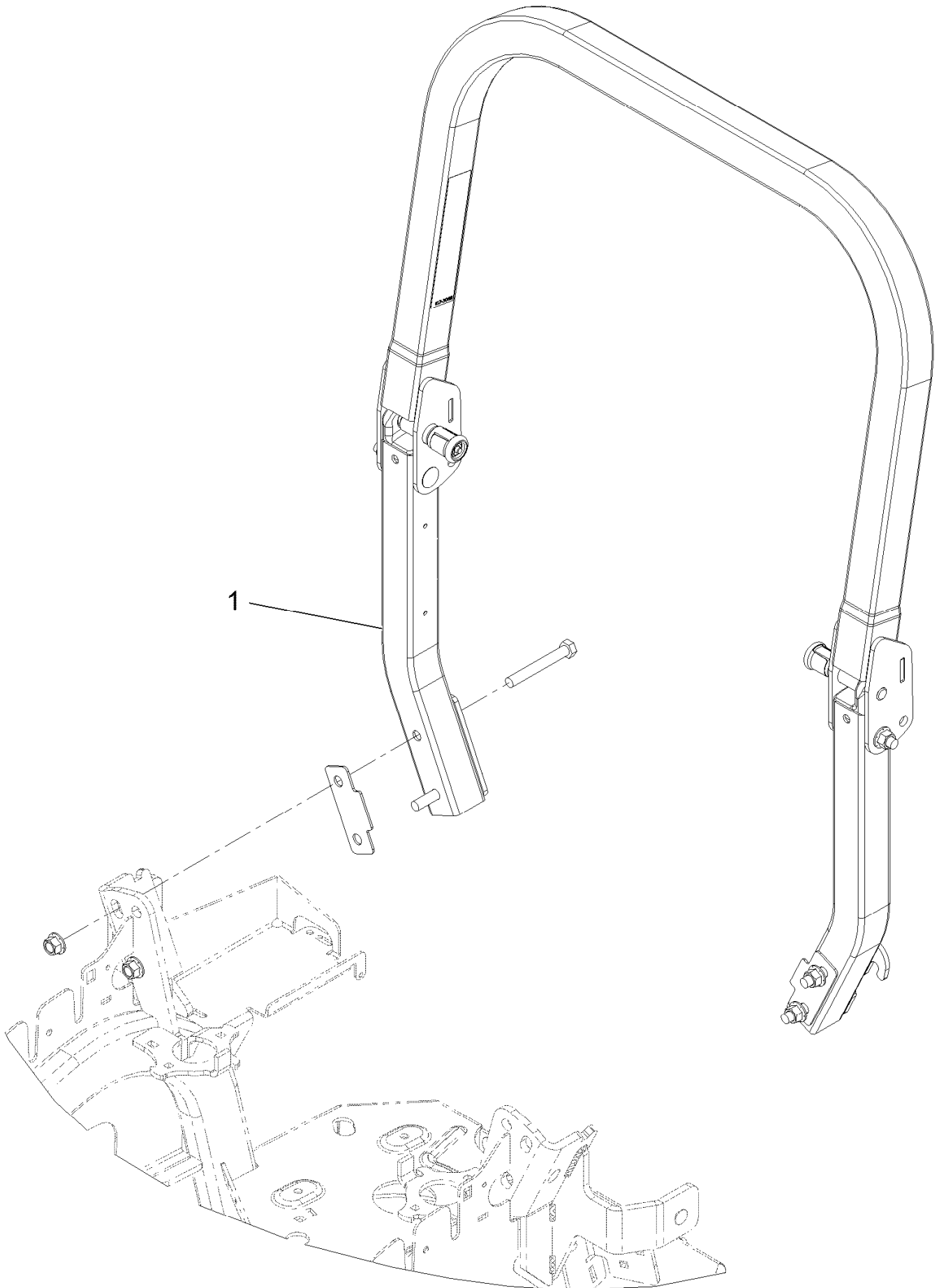

Roll-Over Protection System (continued)

<i>Ref.</i>	<i>Part Number</i>	<i>Qty.</i>	<i>Description</i>
1	116-2882	1	ROPS ASM

Roll-Over Protection System Assembly

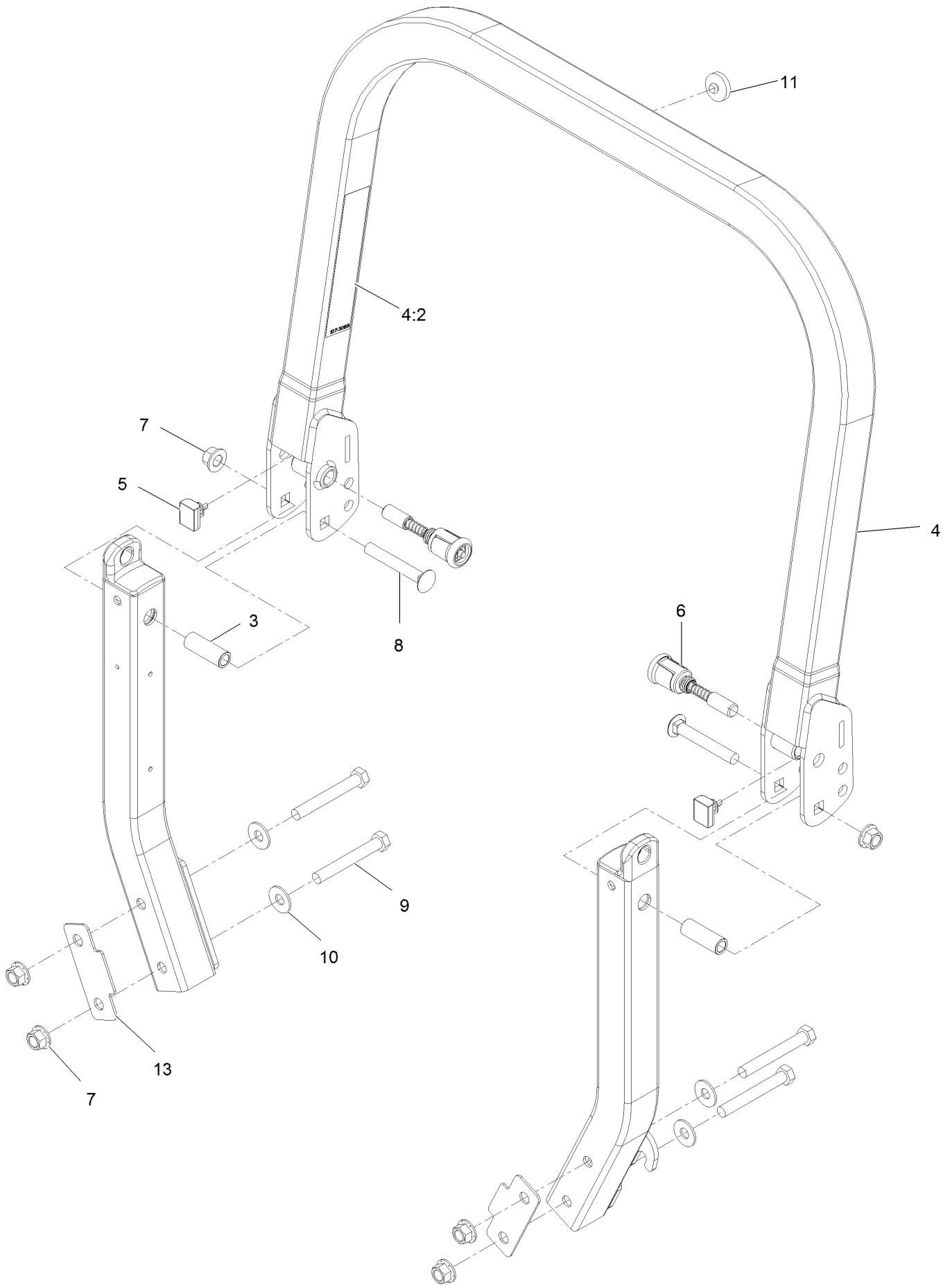

Roll-Over Protection System Assembly (continued)

<i>Ref.</i>	<i>Part Number</i>	<i>Qty.</i>	<i>Description</i>	<i>Ref.</i>	<i>Part Number</i>	<i>Qty.</i>	<i>Description</i>
3	109-6653	2	Spacer	8	3233-10	2	Bolt-Carriage 1/2-13 X 3 1/2
4	116-0019	1	Upper ROPS ASM	9	325-35	4	Screw-HH
4:2	107-3069	1	Decal-Warning	10	109-9505	4	Washer, Spring Disc 1/2
5	109-5337	2	Bumper-ROPS	11	109-9233	1	Bumper-Push-In, Rubber
6	116-0104	2	Pin-Spring	13	116-0960	2	Spacer
7	99-5107	8	Nut-Lock 1/2-13				

Front Caster and Fork Assembly

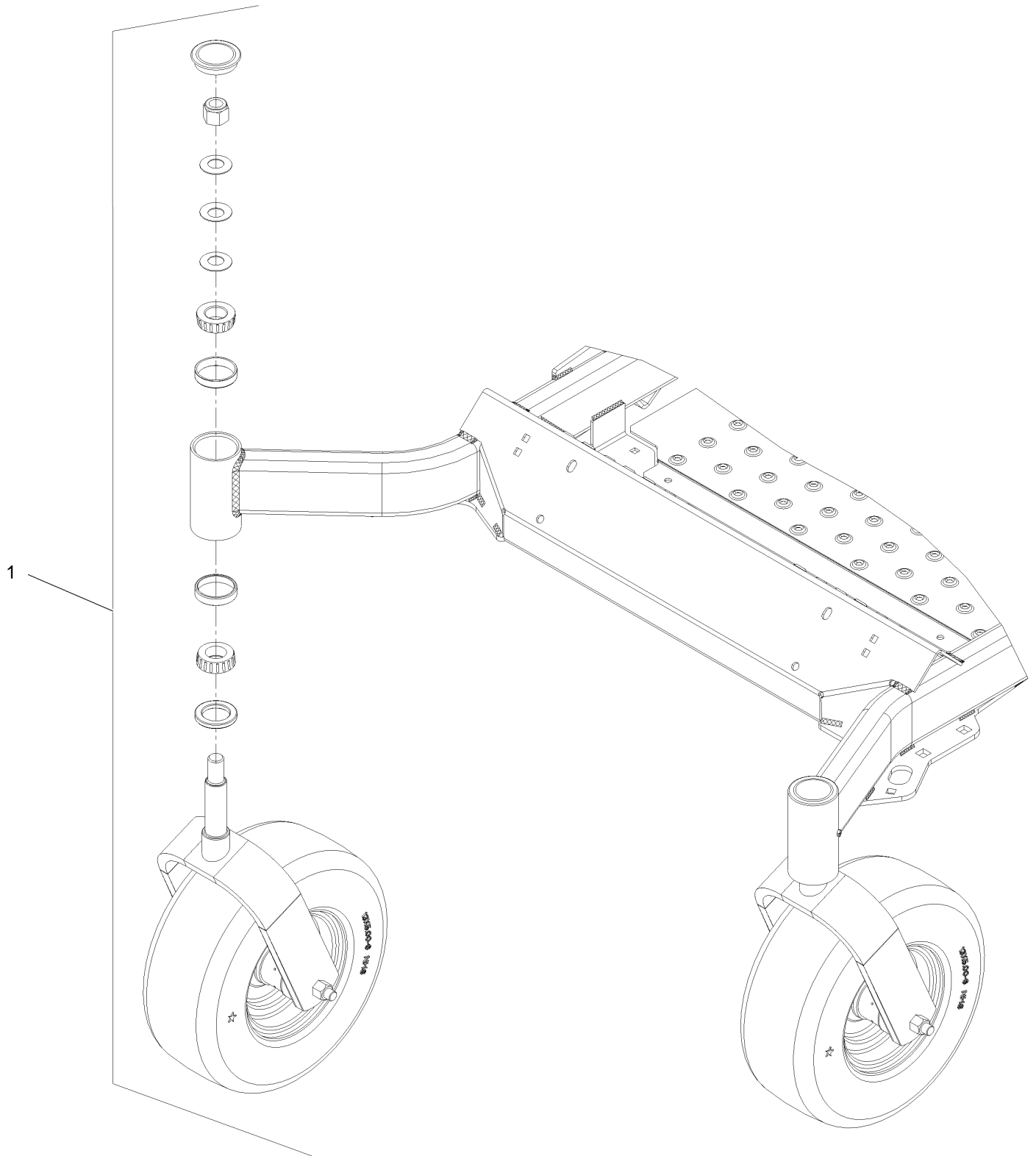

Front Caster and Fork Assembly (continued)

<i>Ref.</i>	<i>Part Number</i>	<i>Qty.</i>	<i>Description</i>
1		2	Front Caster And Fork ASM ●

● Not serviced separately

Caster Wheel and Fork Assembly

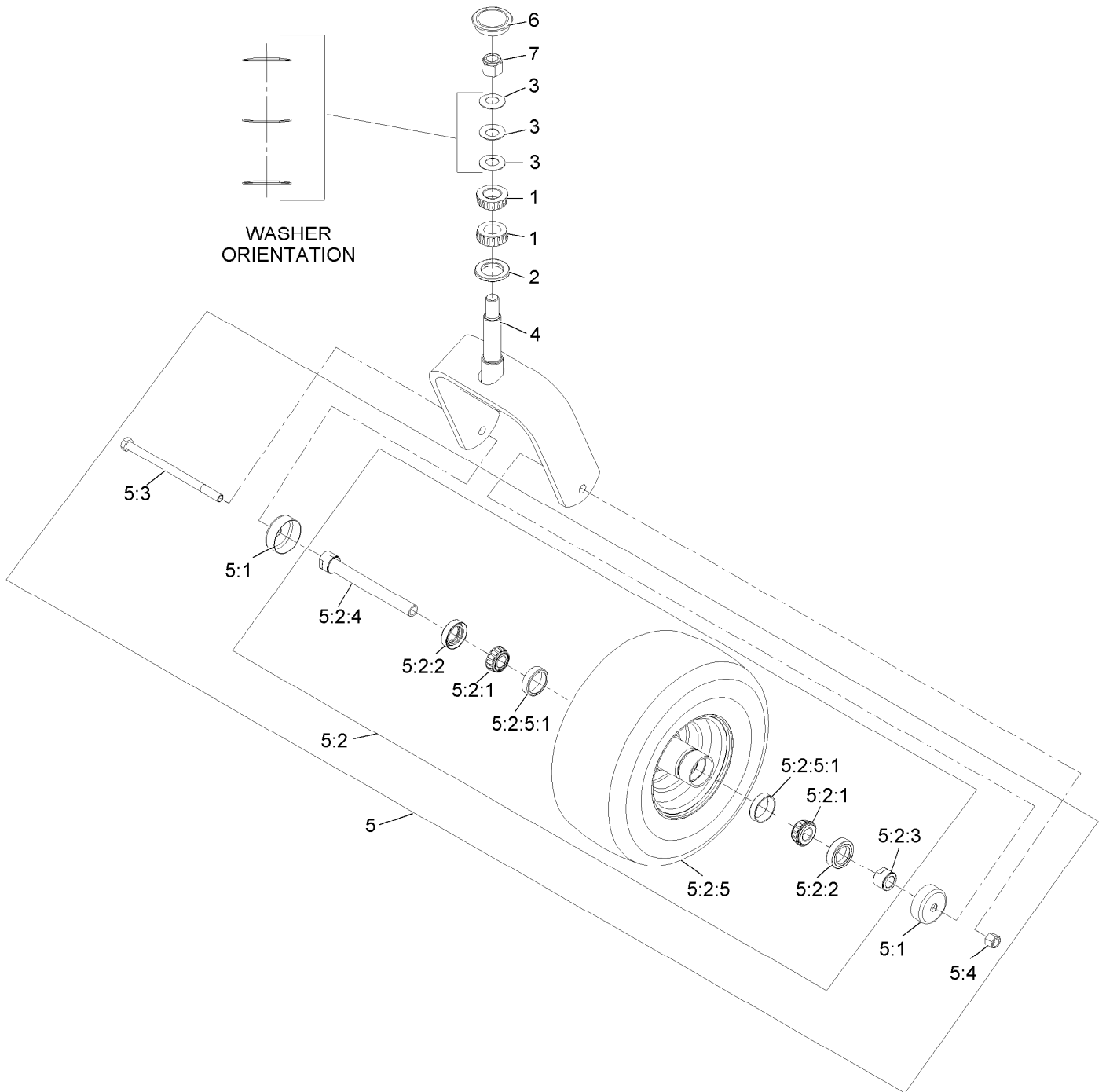

Caster Wheel and Fork Assembly (continued)

<i>Ref.</i>	<i>Part Number</i>	<i>Qty.</i>	<i>Description</i>	<i>Ref.</i>	<i>Part Number</i>	<i>Qty.</i>	<i>Description</i>
1	1-543509	2	Bearing-Roller, Tapered	5:2:3	103-3051	1	Spacer-Nut ■
2	116-5647	1	Seal-Grease	5:2:4	126-5361	1	Axle Caster ASM
3	1-633508	3	Washer-Bellville	5:2:5		1	Wheel And Tire ASM ●
4	116-6707-01	1	Caster	5:2:5:1	1-633584	2	Bearing-Cup
5	109-9127	1	Wheel & Tire ASM	5:3	325-39	1	Screw-HH
5:1	103-2768	2	Guard-Seal	5:4	3296-23	1	Nut-Lock, NI
5:2		1	Wheel And Tire ASM ●	6	103-4882	1	Cap-Grease
5:2:1	1-633585	2	Bearing-Cone, Taper	7	3296-51	1	Nut-Lock, NI
5:2:2	103-0063	2	Seal-Caster				

● Not serviced separately

■ Use Pro-Lock, Nut Type (P/N 1-840022, .5ml tube) on threads.

Deck Lift Assembly

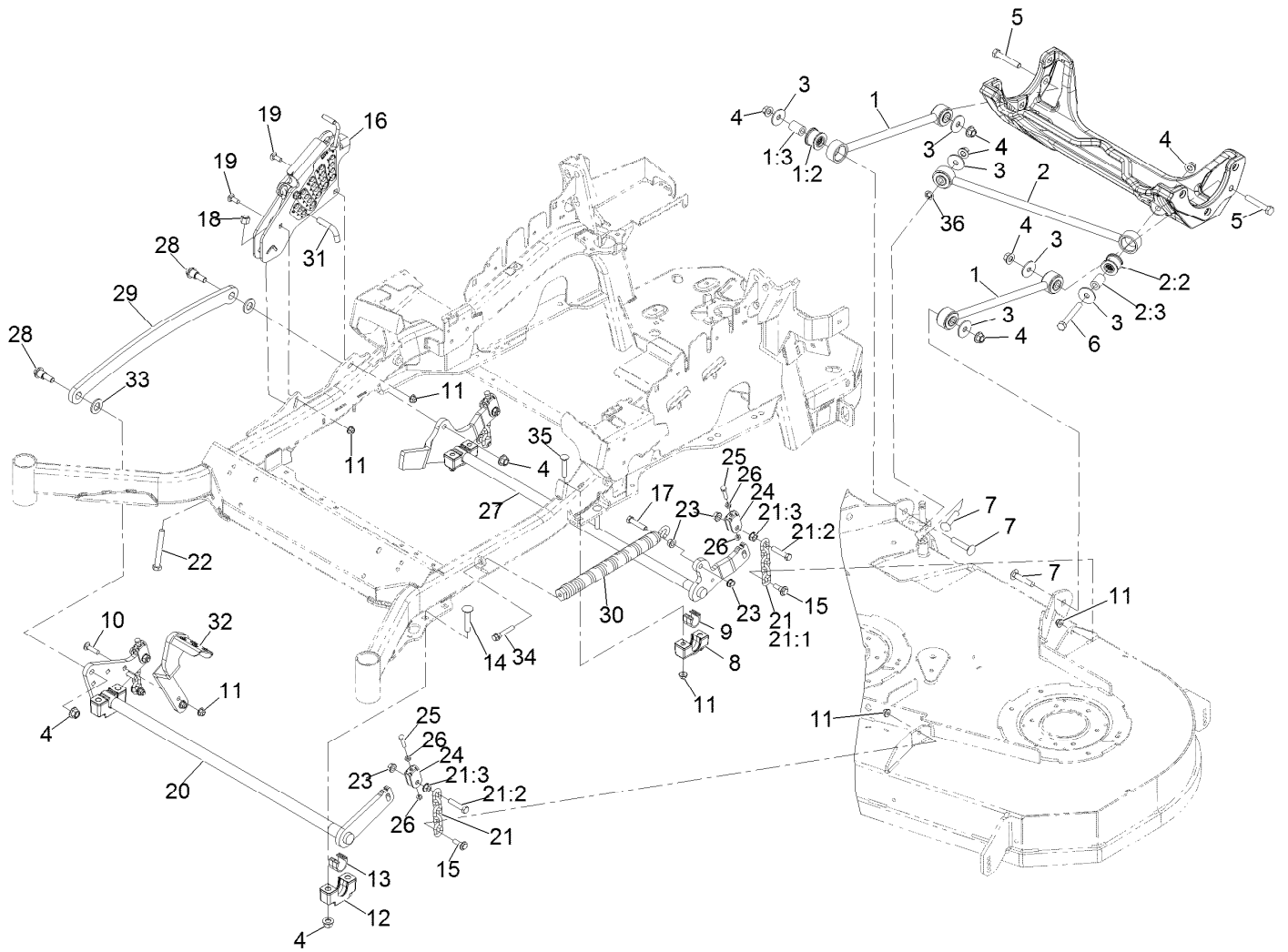

Deck Lift Assembly (continued)

<i>Ref.</i>	<i>Part Number</i>	<i>Qty.</i>	<i>Description</i>	<i>Ref.</i>	<i>Part Number</i>	<i>Qty.</i>	<i>Description</i>
1	109-7952	2	Deck Strut ASM	16	109-7438	1	HOC ASM
1:2	109-5009	2	Bushing-Suspension, Rubber	17	109-9065	1	Screw-HH 7/16-14 X 2
1:3	109-5010	2	Spacer	18	3296-23	1	Nut-Nyloc 1/2-13
2	109-5013	1	Panhard Rod ASM	19	3231-2	2	Bolt-Carriage 3/8-16 X 1
2:2	109-5009	2	Bushing-Suspension, Rubber	20	126-2475-03	1	Decklift-Front
2:3	109-5010	2	Spacer	21	116-0756	4	Deck Lift Chain ASM
3	86-1990	6	Washer	21:1	1-633447	1	Chain-Lift, Deck
4	99-5107	12	Nut-Lock 1/2-13	21:2	109-9065	1	Screw-HH 7/16-14 X 2
5	325-12	2	Screw-HH 1/2-13 X 3	21:3	32128-37	1	Nut-Whizlock 7/16-14
6	325-17	1	Screw-HH 1/2-13 X 4	22	116-0559	1	Bolt-HH 1/2-13 X 4 Tap
7	3233-34	3	Bolt-Carriage 1/2-13 X 2 1/2	23	32128-37	6	Nut-Whizlock 7/16-14
8	127-0553	2	Support-Bearing, Cross Shaft (Rear)	24	109-9066	4	Yoke-Adjust, Deck
9	109-7173	2	Bearing-Cross Shaft, Rear	25	322-47	4	Screw-HH 5/16-18 X 1 1/4
10	3231-4	2	Bolt-Carriage 3/8-16 X 1 1/2	26	3218-2	8	Nut-Jam 5/16-18
11	104-8301	12	Nut-Nyloc 3/8-16 Flg	27	116-0459-03	1	Lift-Deck, Rear
12	109-9409	2	Support-Bearing, Cross Shaft (Front)	28	116-0780	2	Screw-Shoulder HHF 1/2-13 X 1.12
13	109-9410	2	Bearing-Cross Shaft, Front	29	116-0797-03	1	Link-Lift, Deck
14	116-1700	4	Bolt-Carriage 1/2-13 X 2 1/2 Spl Neck	30	116-0000	1	Spring-Extension
15	109-9840	4	Screw-Hex Flange 3/8-16 X .80	31	116-5584	1	Pin-HOC
				32	116-1919-01	1	Lever-Foot
				33	3256-28	2	Washer-3/4 SAE
				34	92-7674	1	Screw-Shcs 3/8-16 X 2.212
				35	3231-7	4	Bolt-Carriage 3/8-16 X 2 1/4
				36	126-2916	1	Nut-Push

Height-of-Cut Assembly No. 109-7438

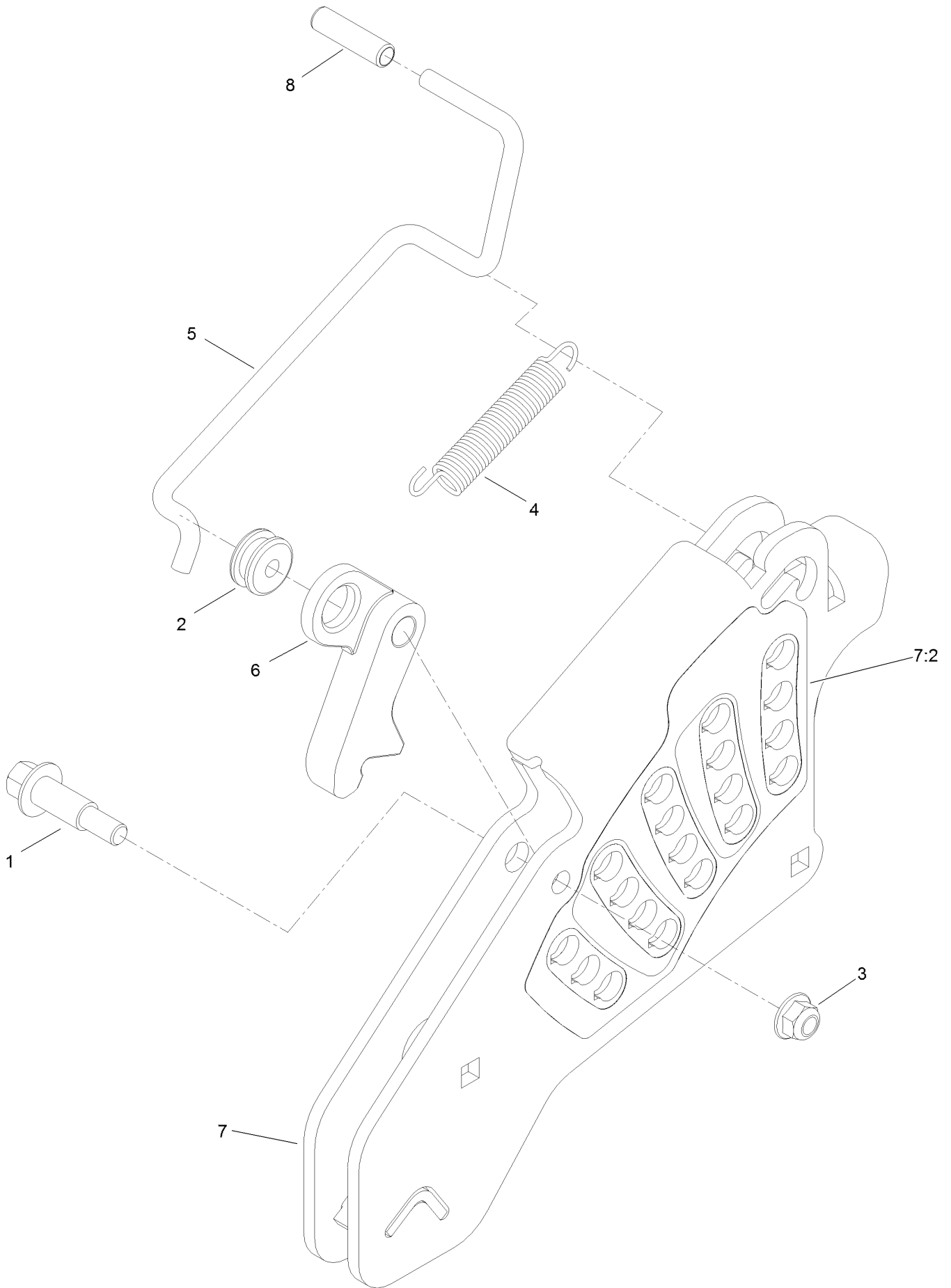

Height-of-Cut Assembly No. 109-7438 (continued)

<i>Ref.</i>	<i>Part Number</i>	<i>Qty.</i>	<i>Description</i>	<i>Ref.</i>	<i>Part Number</i>	<i>Qty.</i>	<i>Description</i>
1	62-1330	1	Bolt-Shoulder	6	116-0118	1	Pawl-Transport, HOC
2	109-7130	1	Grommet	7	109-7335	1	HOC Plate ASM
3	104-8301	1	Nut-HF, NI	7:2	126-4398	1	Decal-HOC
4	109-7124	1	Spring-Extension	8	109-8250	1	Grip-Lever
5	109-7128	1	Rod-Lock, Transport				

Console Assembly

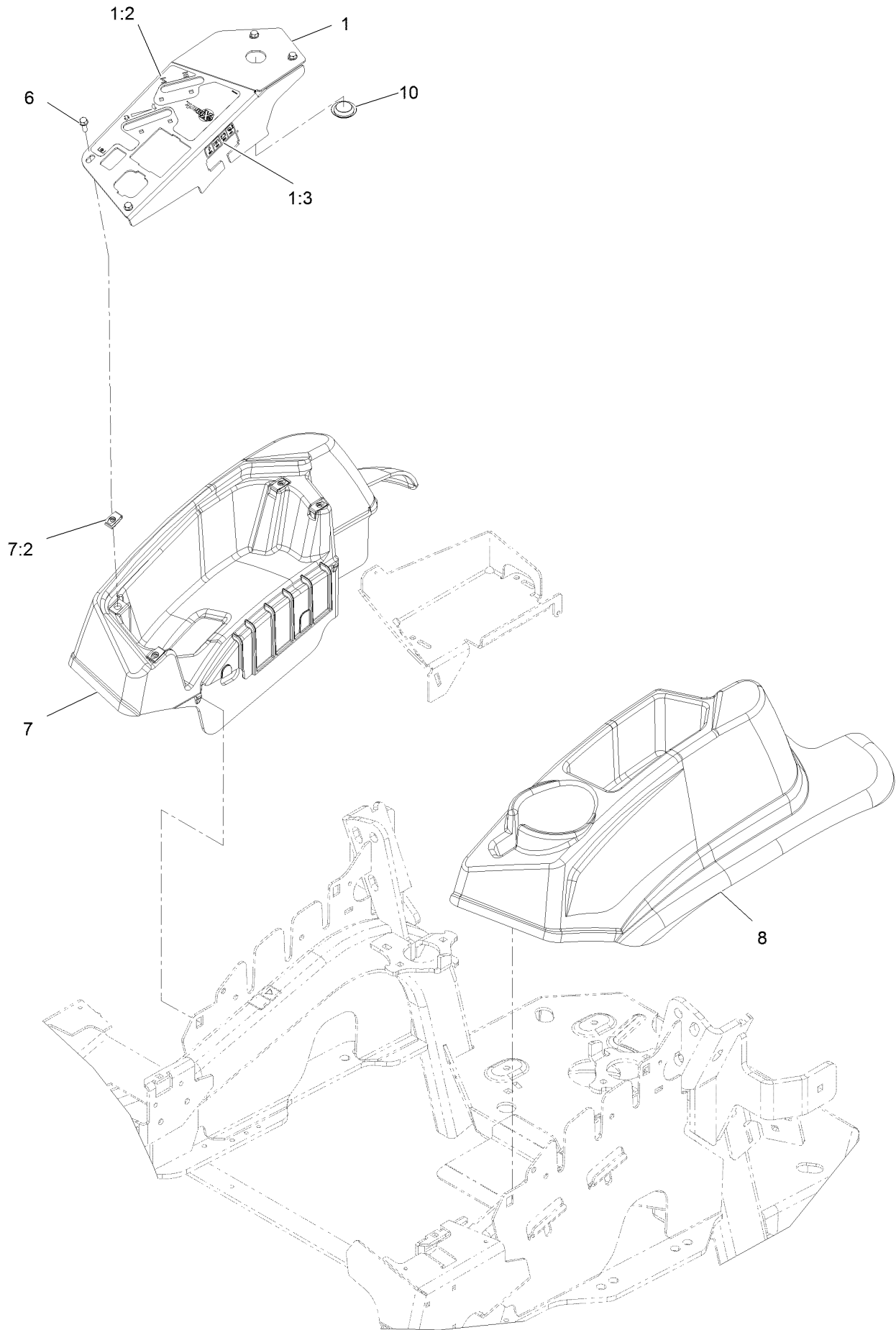

Console Assembly (continued)

<i>Ref.</i>	<i>Part Number</i>	<i>Qty.</i>	<i>Description</i>	<i>Ref.</i>	<i>Part Number</i>	<i>Qty.</i>	<i>Description</i>
1	109-8484	1	Console,Panel W/Decal	7	116-1278	1	Console,RH As ASM
1:2	116-8724	1	Decal-Control Panel Non-EFI	7:2	107069	4	Nut-Retainer-Panel 1/4-20
1:3	114-4466	1	Decal-Fuses	8	109-9457	1	Console, LH As
6	32105-15	4	Screw-Machine 1/4-20 X 3/4	10	116-1875	1	Plug-Plastic

Motion Control Assembly

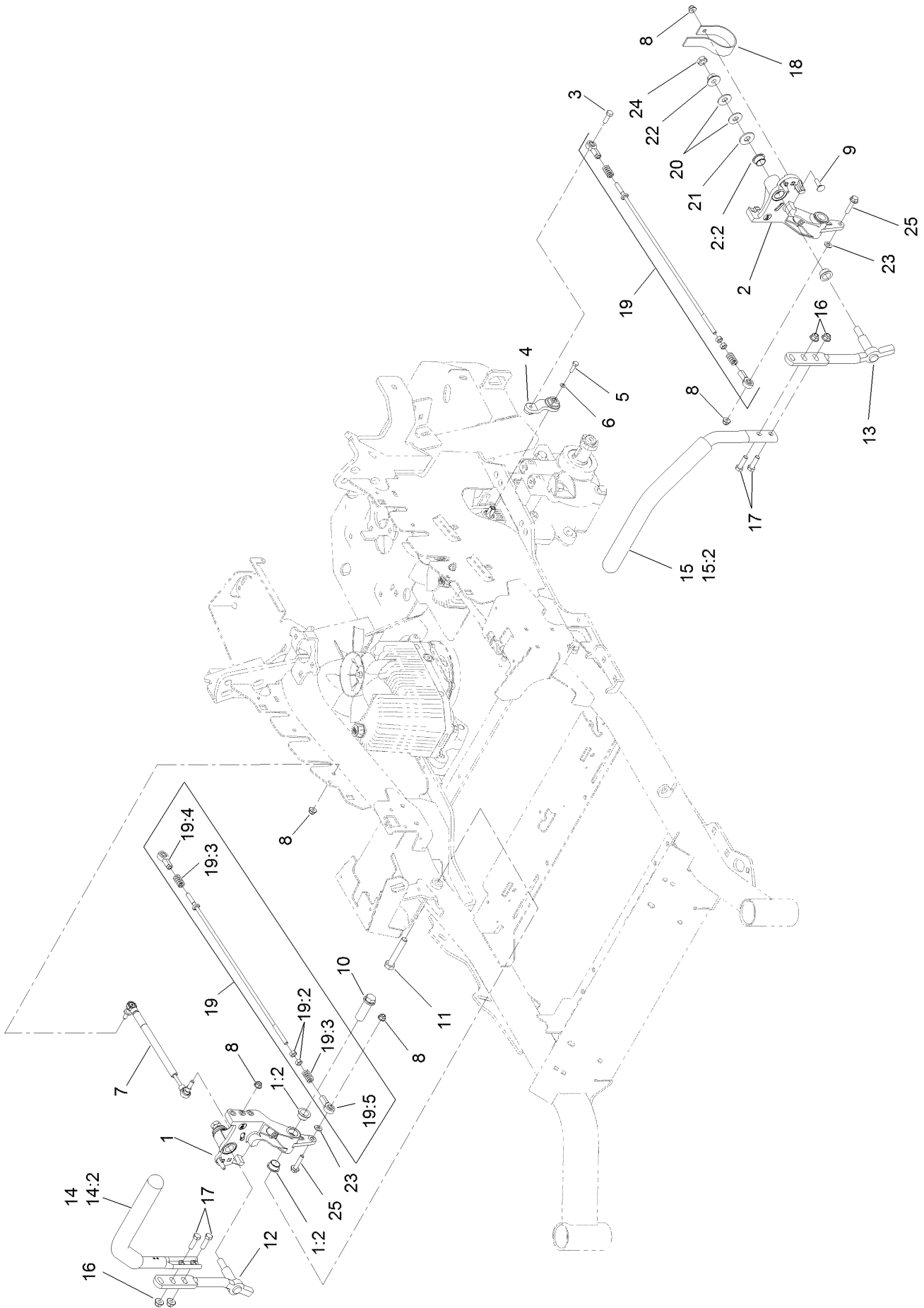

Motion Control Assembly (continued)

<i>Ref.</i>	<i>Part Number</i>	<i>Qty.</i>	<i>Description</i>	<i>Ref.</i>	<i>Part Number</i>	<i>Qty.</i>	<i>Description</i>
1	116-0880	1	RH Motion Control And Bushing ASM	14	135-4371	1	RH Handle ASM
1:2	109-8054	4	Bushing-Flange	14:2	109-5668	1	Grip-Lever, Control
2	116-0881	1	LH Motion Control And Bushing ASM	15	135-4373	1	LH Handle ASM
2:2	109-8054	4	Bushing-Flange	15:2	109-5668	1	Grip-Lever, Control
3	116-0648	2	Screw-HH, Thread Locking ●	16	104-8301	4	Nut-HF, NI
4	109-4581	2	Arm-Control, Pump	17	323-7	4	Screw-HH
5	9080046	2	Screw-HH ●	18	109-5575	2	Spring-Leaf
6	1-303435	2	Washer-Spring	19	109-8106	2	Front Pump Linkage ASM
7	116-0027	2	Damper-Control, Motion	19:2	3219-2	2	Nut-Hex
8	104-8300	8	Nut-HF, NI	19:3	1-323245	2	Spring-Compression
9	3230-2	2	Bolt-CARR	19:4	1-633152	1	Balljoint-LH
10	109-5891	2	Hub-Threaded	19:5	1-543017	1	Balljoint-RH
11	325-12	2	Screw-HH	20	109-9505	4	Washer-Spring
12	116-0039	1	Lever-Control Motion, RH	21	3256-6	2	Washer-Flat
13	116-0040	1	Lever-Control Motion, LH	22	32128-56	2	Nut-HF
				23	3256-23	2	Washer-Plain
				24	3218-5	2	Nut-Jam
				25	115-1794	2	Screw-HHF

● Use Pro-Lock, Nut Type (P/N 1-840022, .5ml tube) on threads.

Rear Wheel Assembly

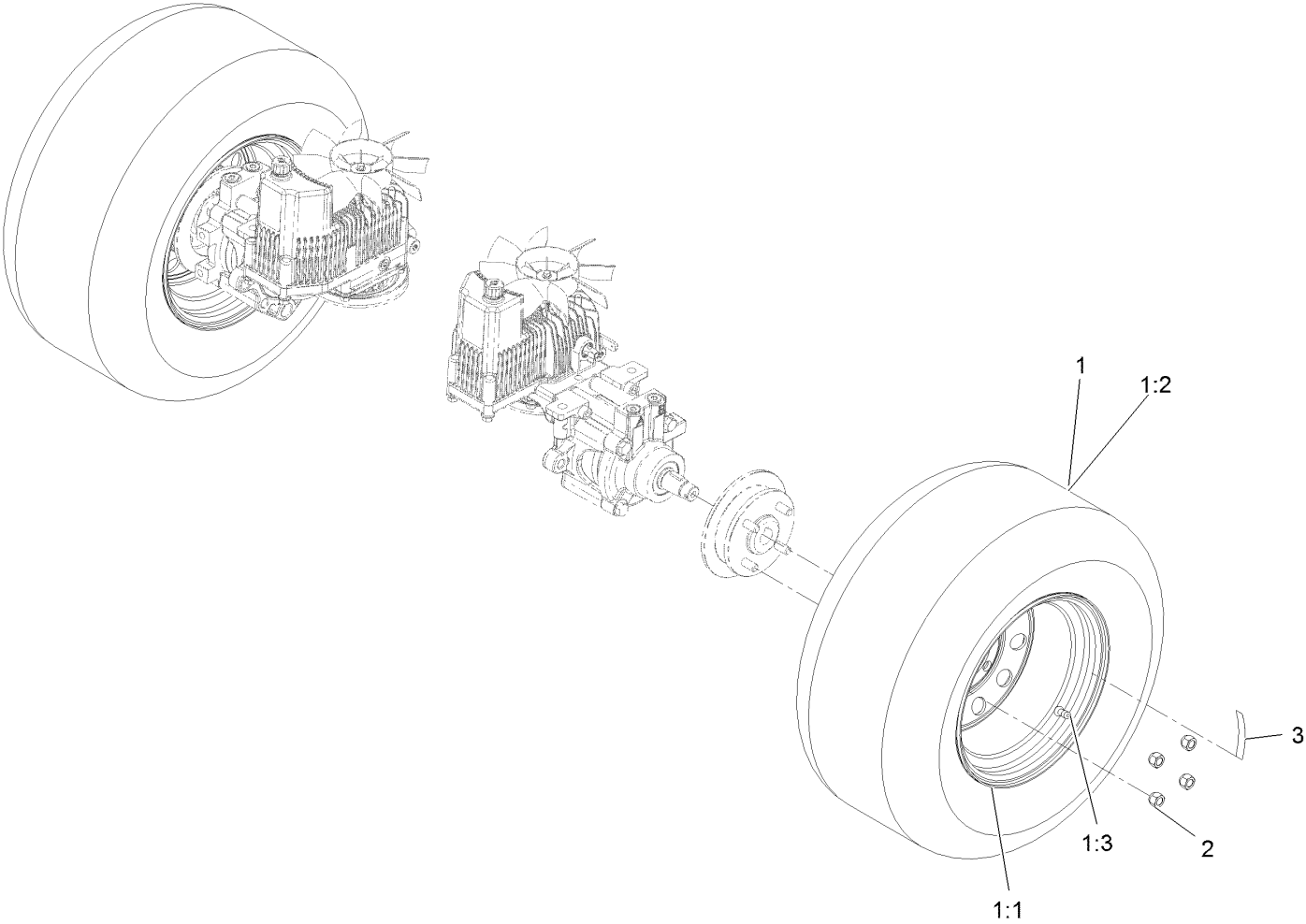

Rear Wheel Assembly (continued)

<i>Ref.</i>	<i>Part Number</i>	<i>Qty.</i>	<i>Description</i>	<i>Ref.</i>	<i>Part Number</i>	<i>Qty.</i>	<i>Description</i>
1	126-4182	2	ASM-Wheel And Tire	2	242-50	8	Nut-Lug 1/2-20
1:1	126-4181	1	ASM-Rim 72	3	126-2055	2	Decal-Torque, Wheel Hub Lug
1:2	116-8296	1	Tire-Drive				
1:3	232-27	1	Stem-Valve				

Park Brake Assembly

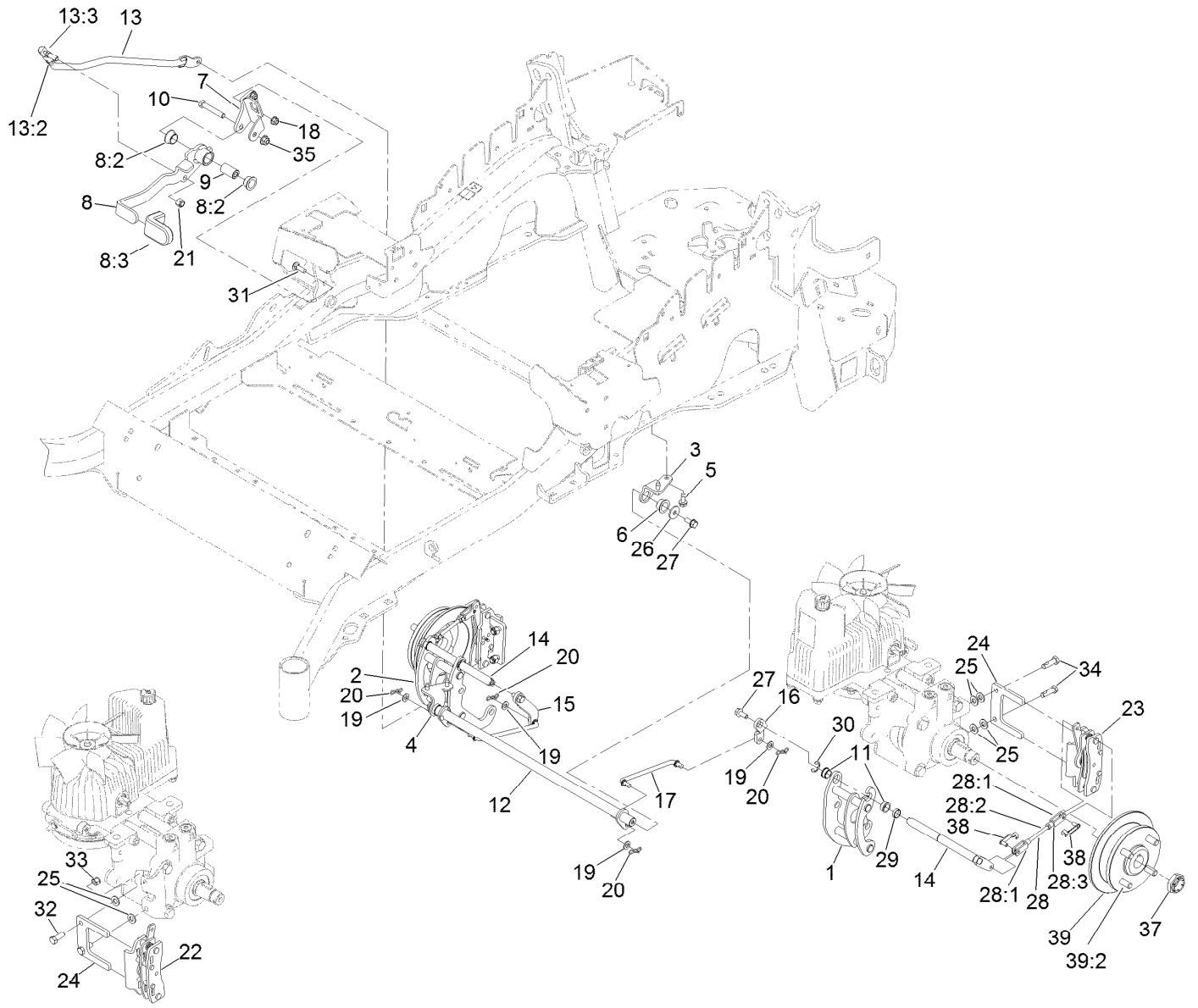

Park Brake Assembly (continued)

<i>Ref.</i>	<i>Part Number</i>	<i>Qty.</i>	<i>Description</i>	<i>Ref.</i>	<i>Part Number</i>	<i>Qty.</i>	<i>Description</i>
1	126-4248	1	Mount-Bellcrank, LH	20	119-1415	4	Pin-Cotter, Locking
2	126-4249	1	Mount-Bellcrank, RH	21	3296-6	1	Nut-Nyloc 3/8-24
3	116-9681	1	Mount-Pivot, LH	22	135-7440	1	Caliper-Brake, RH
4	116-9682	1	Mount-Pivot, RH	23	135-7441	1	Caliper-Brake, LH
5	32144-70	4	Screw-HWH 5/16-18 X 3/4 Tf	24	135-7828	2	Plate-Mount, Brake
6	109-8054	2	Bushing-Flanged	25	3256-24	6	Washer-3/8 SAE
7	116-9096-01	1	Bracket-Mount	26	115-7109	2	Washer-Flat
8	135-7565	1	Brake Lever ASM	27	98-9940	4	Screw-HHF
8:2	109-8054	2	Bushing-Flanged	28	126-7587	2	Rear Linkage ASM
8:3	132-4749	1	Grip-Lever	28:1	126-7588	2	Yoke
9	116-9117	1	Pivot-Handle, Brake	28:2	116-9069	1	Linkage, Rear
10	323-11	1	Screw-HH 3/8-16 X 2 1/4	28:3	3220-1	1	Nut-Jam 1/4-28
11	126-6199	4	Bushing	29	126-6200	2	Spacer
12	135-7800	1	Shaft-Cross	30	32120-19	2	E-Ring
13	135-7805	1	ASM, Front Linkage	31	3230-2	2	Bolt-Carriage 5/16-18 X 1
13:2	94-7572	1	End-Tie Rod, RH	32	135-7915	2	Screw-HH,
13:3	3220-3	1	Nut-Jam 3/8-24	33	112-0236	2	Nut-Lock
14	126-4251	2	Bellcrank	34	135-7890	2	Screw-HH, Patch,
15	126-3716	1	Arm-Inner, RH	35	104-8301	1	Nut-Nyloc 3/8-16 Flg
16	126-3715	1	Arm-Inner, LH	37	116-1399	2	Locknut
17	135-7583	2	Link-Mid	38	126-6395	4	Pin-Clevis, Spring
18	104-8300	2	Nut-Nyloc 5/16-18 Flg	39	142-2701	2	Wheel Hub ASM
19	3256-23	4	Washer-5/16 SAE	39:2	116-1696	4	Stud-Wheel

Seat Assembly

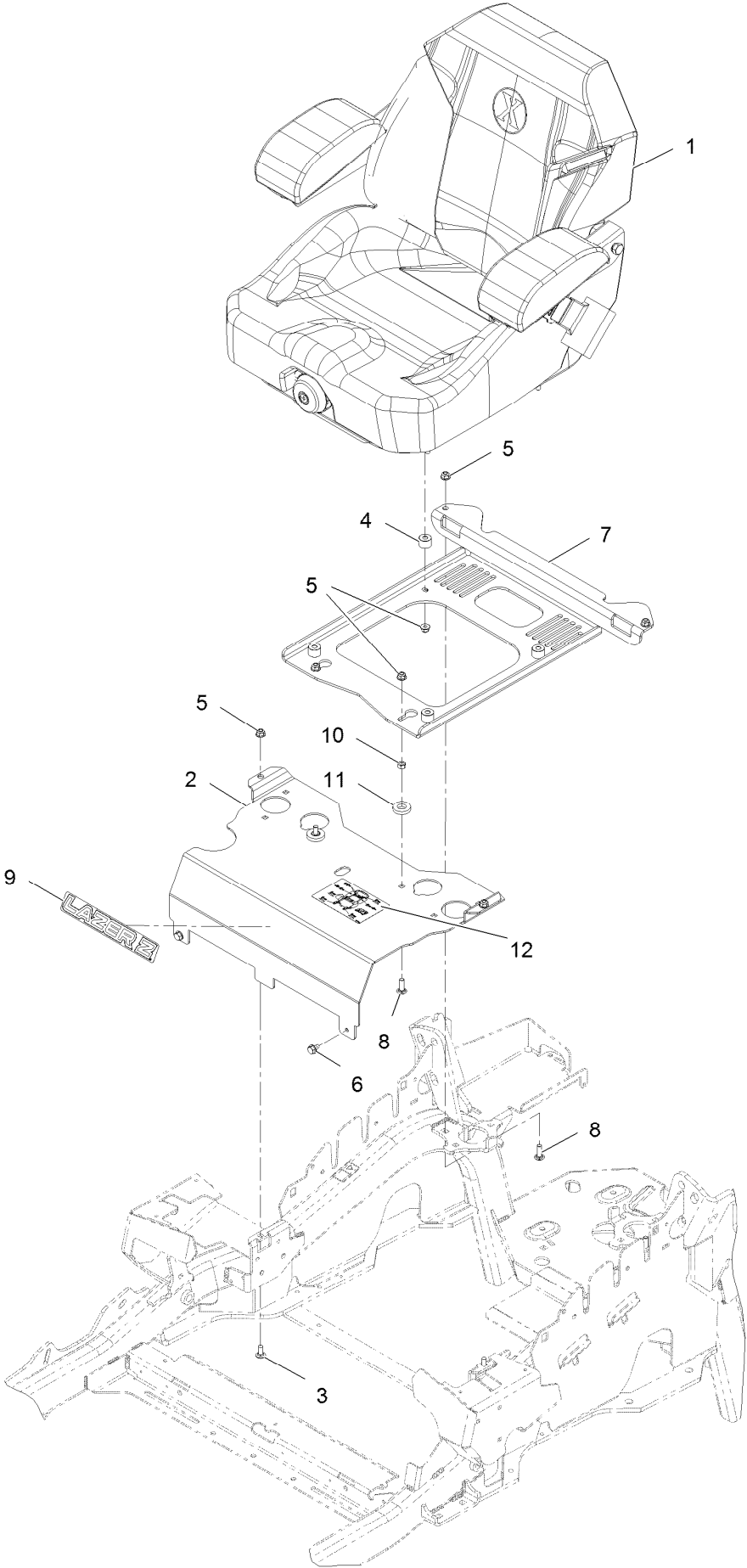

Seat Assembly (continued)

<i>Ref.</i>	<i>Part Number</i>	<i>Qty.</i>	<i>Description</i>	<i>Ref.</i>	<i>Part Number</i>	<i>Qty.</i>	<i>Description</i>
1	116-8912	1	Kit-Suspension Seat	7	116-0192-03	1	Plate-Support, Seat
2	116-2130-03	1	Panel-Front, Seat Mount	8	3230-22	4	Bolt-Carriage 5/16-18 X 1 Sp
3	3230-23	2	Bolt-Carriage 5/16-18 X 3/4 Short Neck	9	126-6574	1	Decal, Lazer Model
4	116-9329	4	Spacer	10	3217-6	2	Nut-Hex 5/16-18
5	104-8300	10	Nut-Nyloc 5/16-18 Flg	11	1-323539	2	Spacer-Blade Drive
6	9266934	2	Screw-HWH 5/16 X 1/2 Tf	12	114-4465	1	Decal-Service Aid

Seat Assembly (cont.)

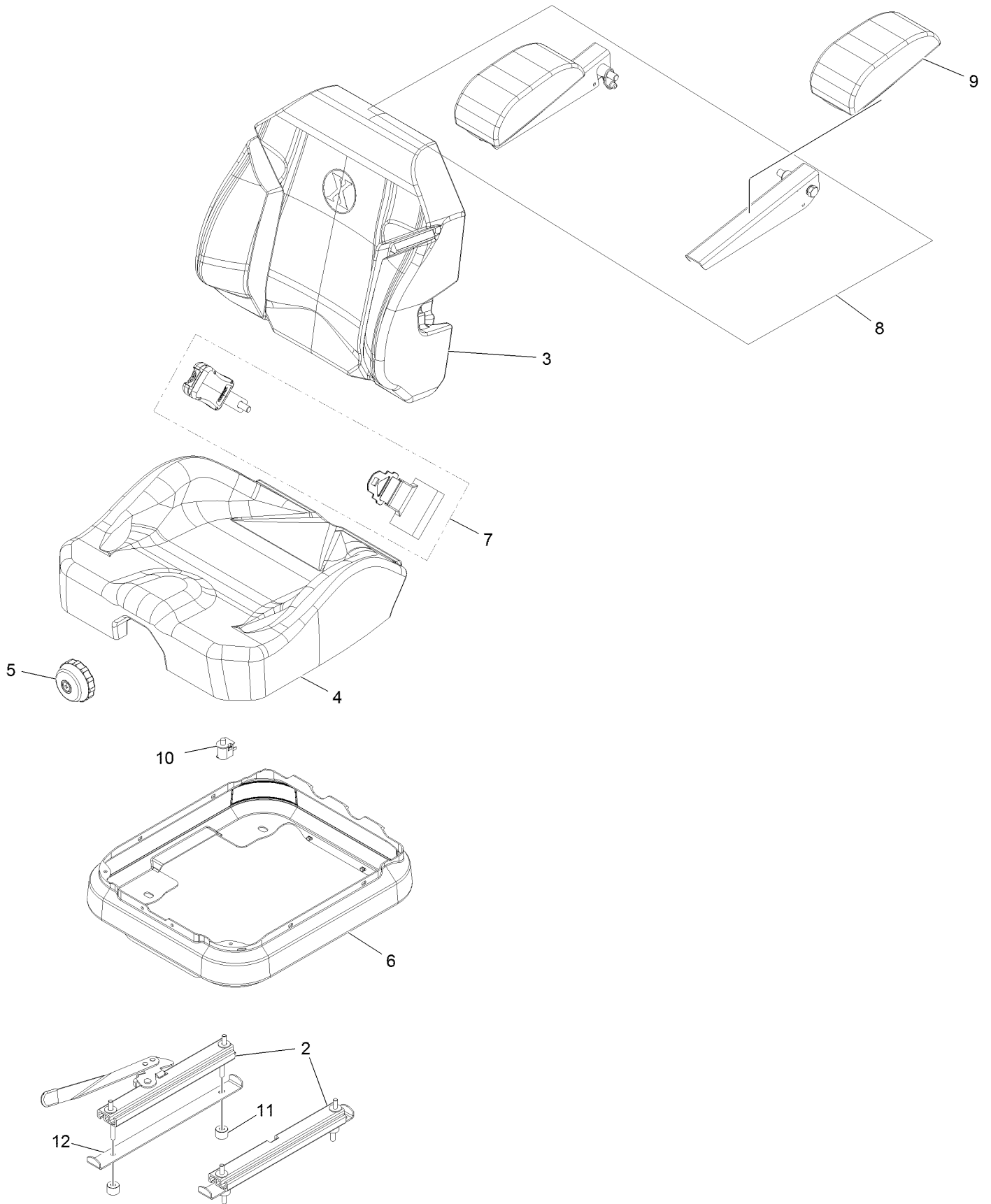

Seat Assembly (cont.) (continued)

<i>Ref.</i>	<i>Part Number</i>	<i>Qty.</i>	<i>Description</i>	<i>Ref.</i>	<i>Part Number</i>	<i>Qty.</i>	<i>Description</i>
2	116-8910	1	Seat Track Set	7	126-2061	1	Seat Belt Service Kit
3	116-8908	1	Cover-Back 311463Vn500	8	116-8906	1	Kit-Arm Rest Set
4	116-8909	1	Cover-Cushion 311464Vn500	9	116-8905	1	Kit-Arm Rest Pads
5	116-8911	1	Knob-Adjuster	10	82-2190	1	Switch
6	116-5659	1	Cover-Suspension Bellows	11	116-9329	4	Spacer
				12	126-9918-03	2	Stop, Seat ●

● Used on Diesel models only

Fuel System Assembly

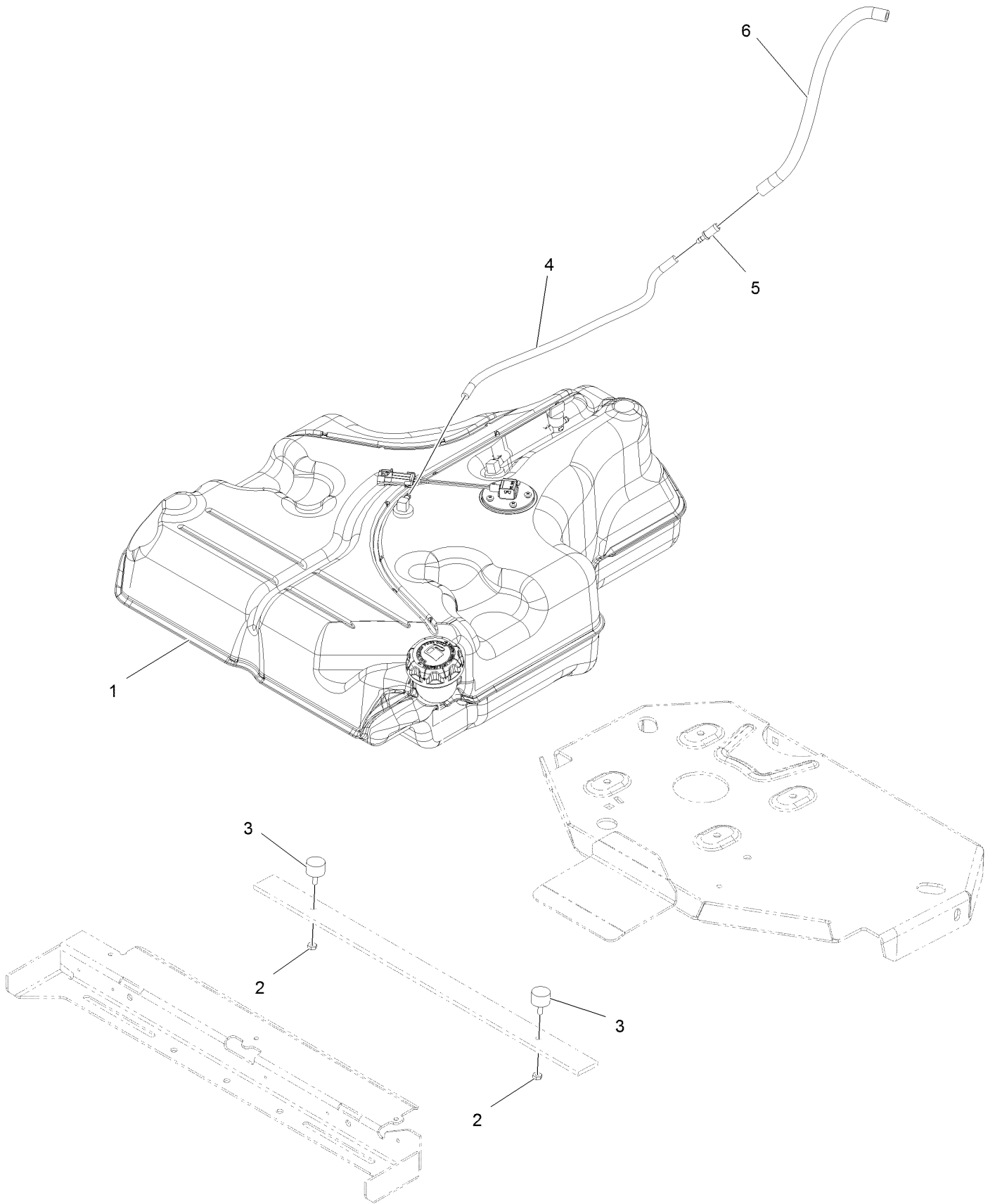

Fuel System Assembly (continued)

<i>Ref.</i>	<i>Part Number</i>	<i>Qty.</i>	<i>Description</i>	<i>Ref.</i>	<i>Part Number</i>	<i>Qty.</i>	<i>Description</i>
1	135-0645	1	Fuel Tank ASM	4	110-8751	1	Hose-Fuel
2	3218-1	2	Nut-Jam 1/4-20	5	98-2952	1	Fitting-Straight
3	1-523420	2	Bumper	6	116-4344	1	Hose-Fuel

Fuel Tank Assembly

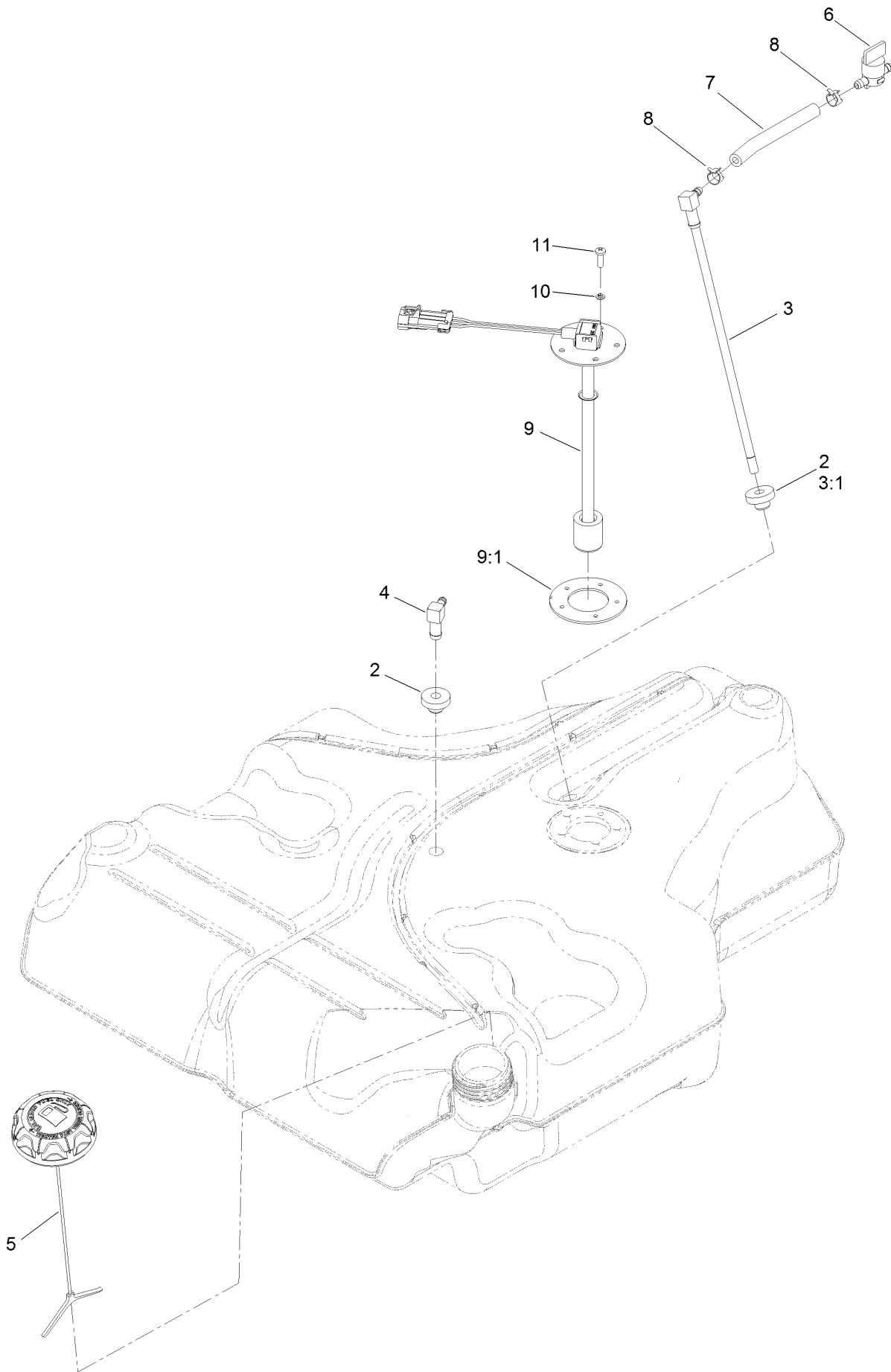

Fuel Tank Assembly (continued)

<i>Ref.</i>	<i>Part Number</i>	<i>Qty.</i>	<i>Description</i>	<i>Ref.</i>	<i>Part Number</i>	<i>Qty.</i>	<i>Description</i>
2	46-6560	2	Bushing	7	109-0650	1	Hose-Fuel
3	116-2459	1	Fuel Line Kit (With Grommet)	8	2412-98	2	Clamp-Hose
3:1	46-6560	1	Bushing	9	126-3949	1	Sender-Level, Fuel (W/Gasket)
4	116-2288	1	Fitting-Elbow, 90 DEG	9:1	126-3950	1	Gasket-Sender
5	126-1789	1	Cap-Fuel, Ratcheting	10	3253-17	5	Washer-Lock
6	1-603770	1	Valve-Fuel	11	3290-500	5	Screw-PPH

Engine Assembly

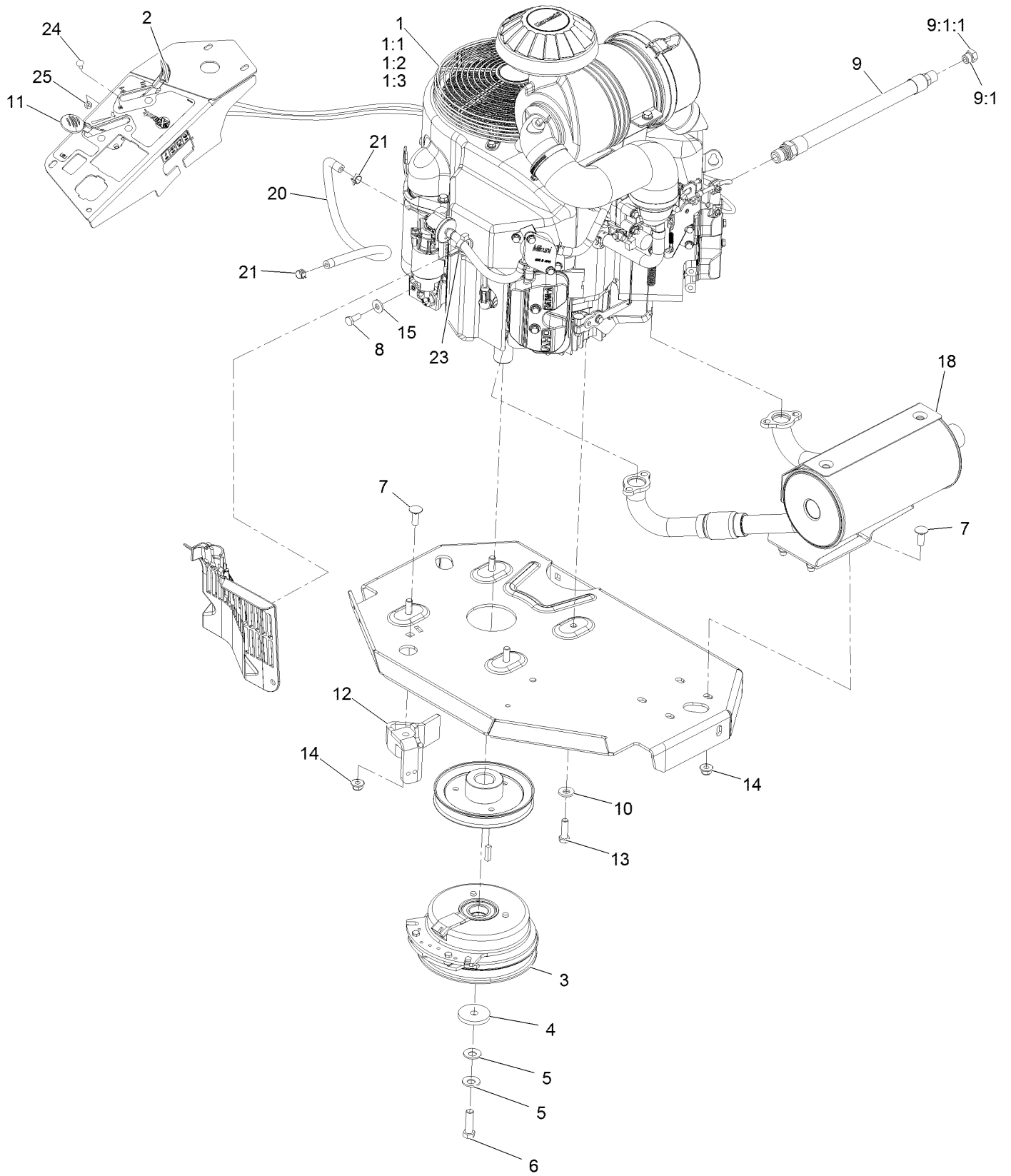

Engine Assembly (continued)

<i>Ref.</i>	<i>Part Number</i>	<i>Qty.</i>	<i>Description</i>	<i>Ref.</i>	<i>Part Number</i>	<i>Qty.</i>	<i>Description</i>
1		1	Engine-Kawasaki, Fx801V-S04-R ▲◆	9:1	353-508	1	Plug-W/O-Ring ●
1:1		1	Kawasaki 49065-7010 Engine Oil Filter ▲◆	9:1:1	237-42	1	O-Ring
1:2		1	Kawasaki 11013-7044 Engine Air Filter ▲◆	10	98-5975	4	Washer-Spring Disc 3/8
1:3		1	Kawasaki 11013-7045 Safety Filter ▲◆	11	116-1972	1	ASM,Throttle Cable
2	109-8167	1	ASM, Choke Cable	12	116-2612-01	1	Clutch-Anchor
3	116-1620	1	Clutch Kit	13	323-7	4	Screw-HH 3/8-16 X 1 1/4
4	109-6919	1	Washer-Clutch	14	104-8301	5	Nut-Nyloc 3/8-16 Flg
5	1-603610	2	Washer-Spring Disc 7/16	15	1-303334	1	Washer-Spring Disc 5/16
6	109-9761	1	Screw-HH 7/16-20 X 1 1/2 W/Loctite □	18	135-5500	1	Muffler, Fx850/801 Flex
7	3231-22	5	Bolt-Carriage 3/8-16 X 1	20	109-0298	1	Line-Fuel
8	33114-020	1	Screw-HH M8-1.25 X 20Mm	21	2412-98	2	Clamp-Hose
9	116-4924	1	Asm-Hose Oil Drain W/Plug ■	23	105-1853	2	Clamp-Hose
				24	1-807513	4	Bolt-Carriage #10-24 X 1/2
				25	3296-2	4	Nut-Nyloc #10-24

● Torque to 24-26 ft-lb

▲ Not serviced separately

□ Use Pro-Lock, Nut Type (P/N 1-840022, .5ml tube) on threads.

■ Torque to 23-29 ft-lb

◆ Obtain parts from www.kawpower.com

Hydraulic Assembly

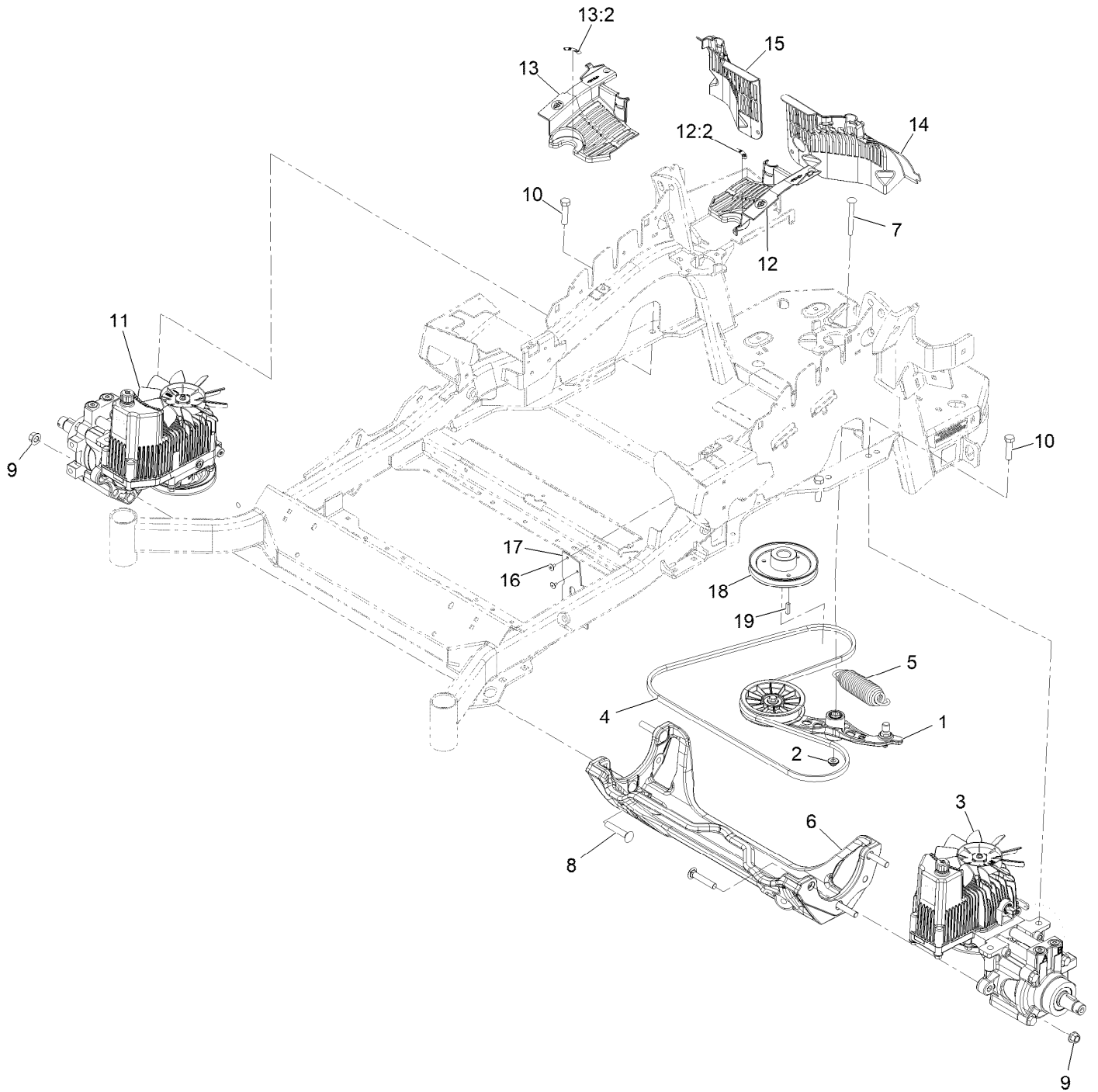

Hydraulic Assembly (continued)

<i>Ref.</i>	<i>Part Number</i>	<i>Qty.</i>	<i>Description</i>	<i>Ref.</i>	<i>Part Number</i>	<i>Qty.</i>	<i>Description</i>
1	116-1255	1	Pump Idler ASM	13	116-0171	1	RH Hydro Guard ASM
2	109-6658	1	Nut-Nyloc 3/8-16 Flg	13:2	116-8726	1	Decal-Oil, Hydro
3	135-7903	1	Hydro-LH	14	109-9057	1	Guard-Hydro, Rear (LH)
4	126-9835	1	Belt-V	15	109-9058	1	Guard-Hydro, Rear (RH)
5	116-6317	1	Spring-Extension	16	1-803035	2	Rivet 3/16 X 1/4
6	116-7558	1	Cradle-Hydro	17	116-2362	1	Deflector-Air Flow
7	116-1502	1	Bolt-Shoulder, Carriage	18	109-9905	1	Sheave
8	126-0095	6	Screw-CARR	19	1-807259	1	Key-Machine 1/4 X 1/4 X 1
9	99-5107	6	Nut-Lock	99	109-9828	1	Oil-HYD, (Quart) ●
10	325-8	4	Screw-HH	99	116-0164	1	Filter-Hydro ●
11	135-7904	1	Hydro-RH	99	116-1218	1	Oil-HYD, 1 Gallon ●
12	116-0170	1	LH Hydro Guard ASM	99	126-8103	1	Kit, Hydro Service ●
12:2	116-8726	1	Decal-Oil, Hydro				

● Not illustrated

LH Hydro Assembly No. 135-7903

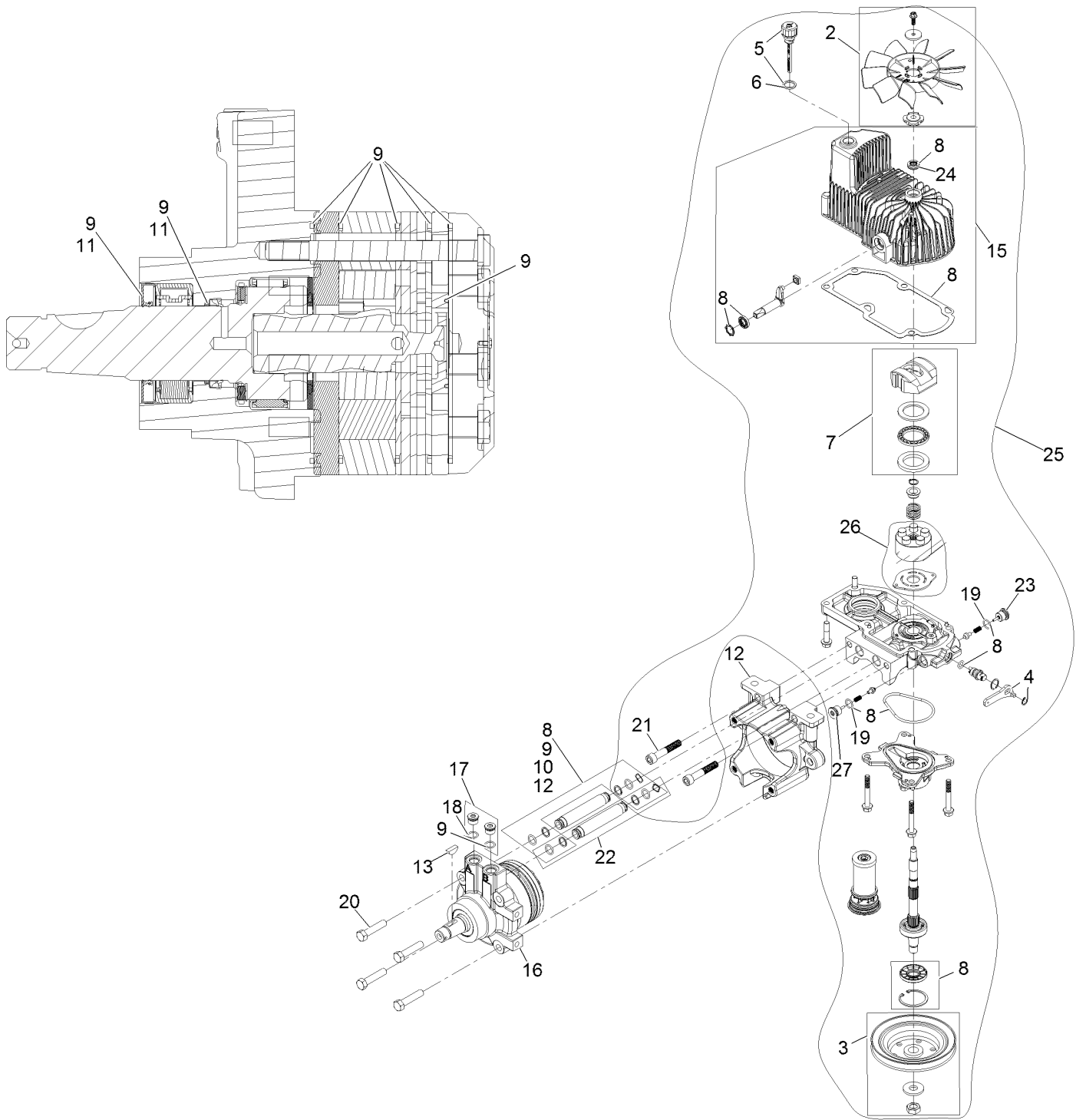

LH Hydro Assembly No. 135-7903 (continued)

<i>Ref.</i>	<i>Part Number</i>	<i>Qty.</i>	<i>Description</i>	<i>Ref.</i>	<i>Part Number</i>	<i>Qty.</i>	<i>Description</i>
2	142-3603	1	Kit, 7.8 In Fan	17	116-7901	1	Magnetic Plugs Service Kit
3	116-0234	1	Pulley Kit	18	76-1900	2	O-Ring
4	116-0235	1	Handle	19	116-8662	2	O-Ring-Valve, Check
5	116-0236	1	Dipstick	20	116-8974	4	Screw-HH 1/2-20 X 2 1/4
6	116-0237	1	Gasket	21	116-8975	2	Screw-HSH 1/2-20 X 2 3/4
7	116-1367	1	Swash Block Kit	22	116-9922	2	Hydraulic Tube Kit
8	142-3604	1	Kit, Pump Seal	23	126-7466	1	Valve-Shock
9	116-1369	1	Motor Seal Kit	24	126-7711	1	Seal-Drive, Fan
10	116-1370	1	Tube Seal Kit	25	142-3609	1	Kit, Pump Section 12Cc LH
11	116-1371	1	Output Shaft Seal Kit	26	142-4500	1	Kit - 12Cc Port Plate, Rotate Grp
12	116-5469	1	Cup-Nose				
13	3257-42	1	Key-Woodruff 5/16 X 1	27	142-4459	1	Shock Valve Orificed 3800
15	142-4460	1	Kit, Housing-Hydro LH	99	116-1373	1	Flow Test Kit ●
16	116-8915	1	Motor-Hydraulic	99	116-4245	1	Puller-Pulley ●

● Not illustrated

RH Hydro Assembly No. 135-7904

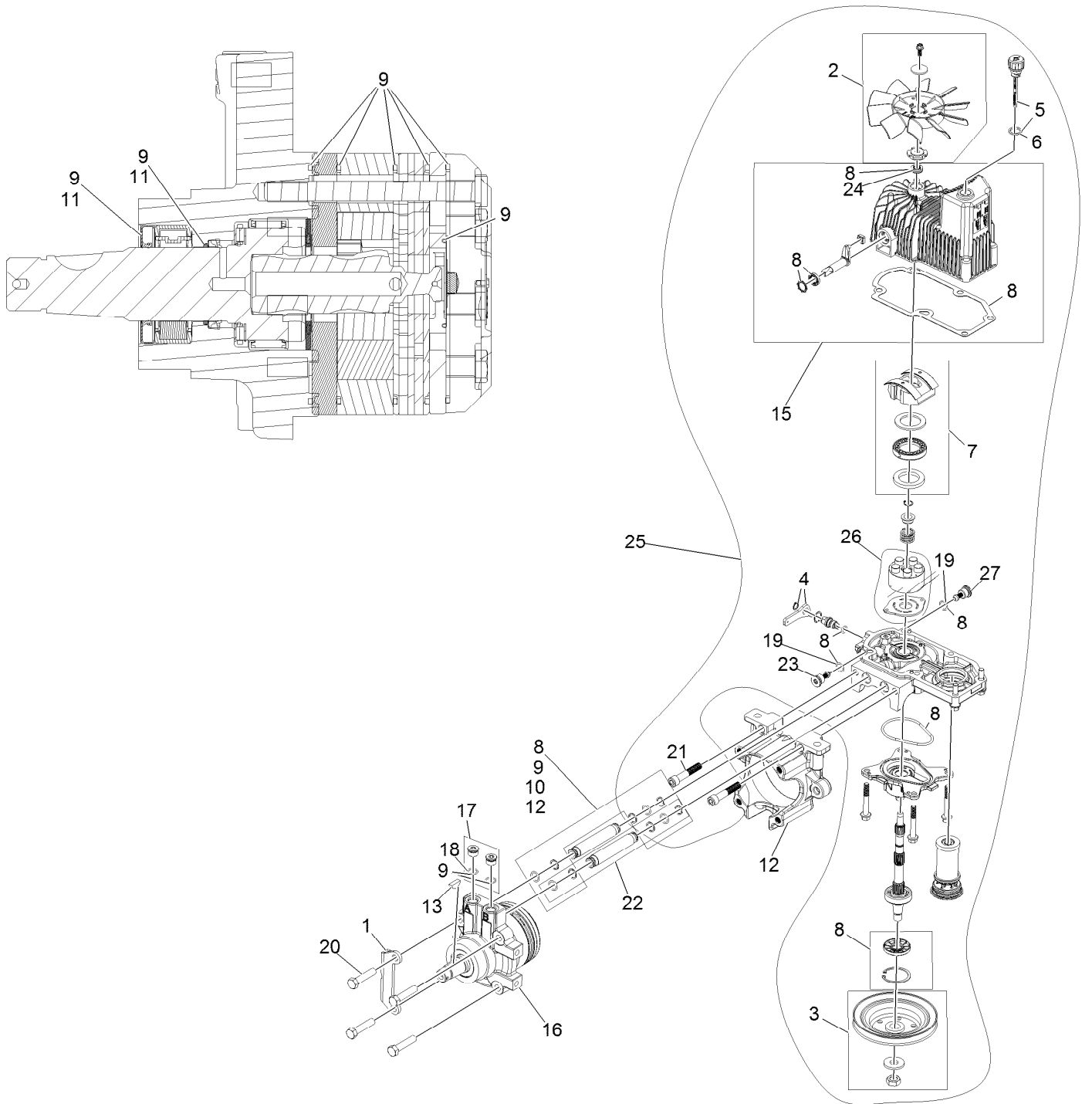

RH Hydro Assembly No. 135-7904 (continued)

<i>Ref.</i>	<i>Part Number</i>	<i>Qty.</i>	<i>Description</i>	<i>Ref.</i>	<i>Part Number</i>	<i>Qty.</i>	<i>Description</i>
1	135-7827	1	Plate, Horse Shoe Mount	17	116-7901	1	Magnetic Plugs Service Kit
2	142-3603	1	Kit, 7.8 In Fan	18	76-1900	2	O-Ring
3	116-0234	1	Pulley Kit	19	116-8662	2	O-Ring-Valve, Check
4	116-0235	1	Handle	20	116-8974	4	Screw-HH 1/2-20 X 2 1/4
5	116-0236	1	Dipstick	21	116-8975	2	Screw-HSH 1/2-20 X 2 3/4
6	116-0237	1	Gasket	22	116-9922	2	Hydraulic Tube Kit
7	116-1367	1	Swash Block Kit	23	126-7466	1	Valve-Shock
8	142-3604	1	Kit, Pump Seal	24	126-7711	1	Seal-Drive, Fan
9	116-1369	1	Motor Seal Kit	25	142-3608	1	Kit, Pump Section 12Cc RH
10	116-1370	1	Tube Seal Kit	26	142-4500	1	Kit - 12Cc Port Plate, Rotate Grp
11	116-1371	1	Output Shaft Seal Kit				
12	116-5469	1	Cup-Nose	27	142-4459	1	Shock Valve Orificed 3800
13	3257-42	1	Key-Woodruff 5/16 X 1	99	116-1373	1	Flow Test Kit ●
15	142-4461	1	Kit, Housing-Hydro RH	99	116-4245	1	Puller-Pulley ●
16	116-8916	1	Motor-Hydraulic RH 240Cc				

● Not illustrated

Pump Idler Assembly No. 116-1255



Pump Idler Assembly No. 116-1255 (continued)

<i>Ref.</i>	<i>Part Number</i>	<i>Qty.</i>	<i>Description</i>	<i>Ref.</i>	<i>Part Number</i>	<i>Qty.</i>	<i>Description</i>
2	43-0940	1	Spacer	8	323-8	1	Screw-HH
3	103-3504	2	Bearing-Spherical	9	32120-10	2	Ring-Snap
4	103-3505	1	Seal-Lip, Double	10	302-19	1	Fitting-Grease
5	103-3506	1	Seal-Lip, Single	11	109-8076	1	Pulley-Idler
6	109-6658	1	Nut-Flange, NI	12	132-4724	1	Pin-Anchor, Spring
7	106-7159	2	O-Ring				

Electrical Assembly

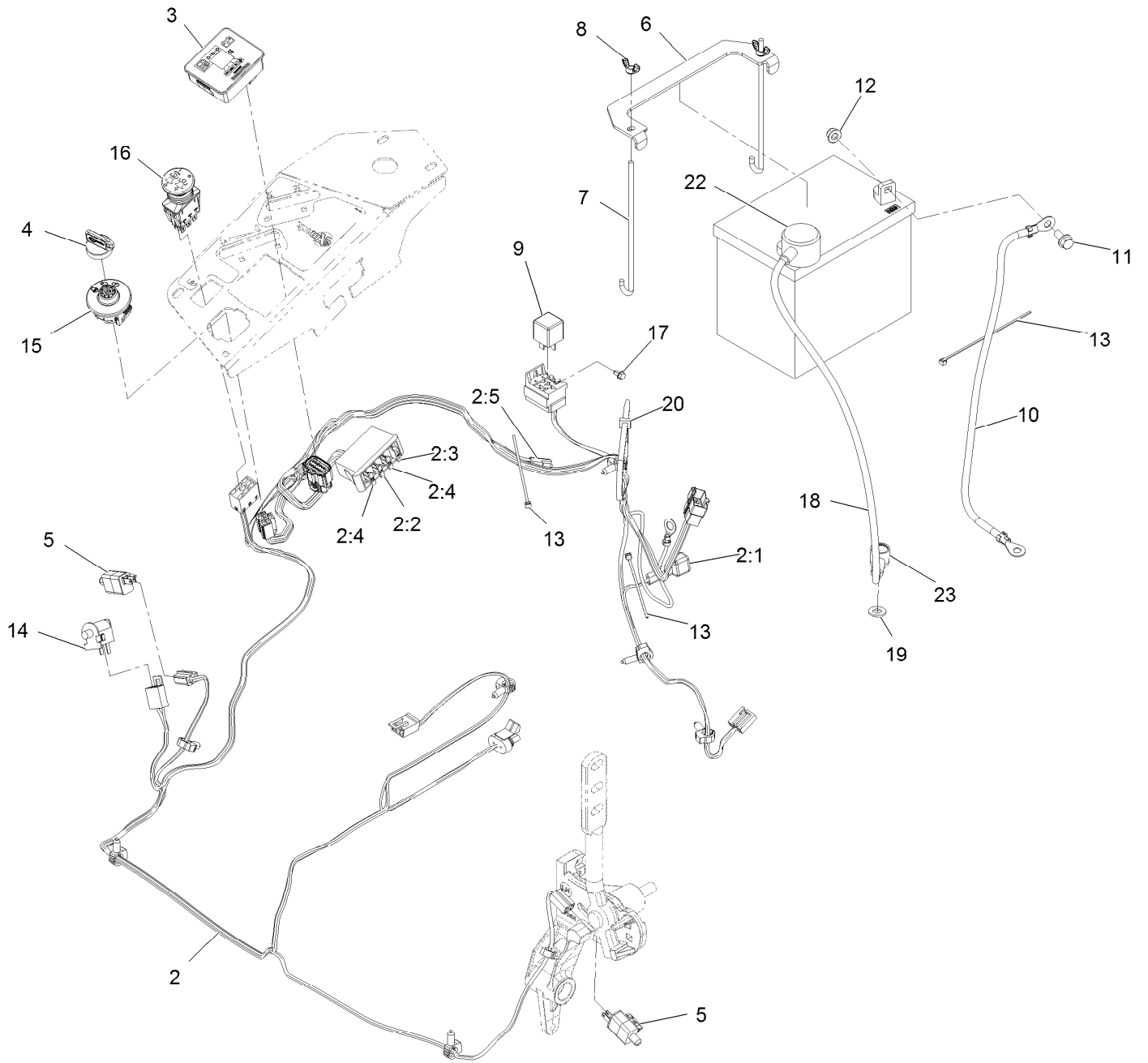

Electrical Assembly (continued)

<i>Ref.</i>	<i>Part Number</i>	<i>Qty.</i>	<i>Description</i>	<i>Ref.</i>	<i>Part Number</i>	<i>Qty.</i>	<i>Description</i>
2	116-6009	1	Harness-Wire, Main ●	10	114-1218	1	Cable-Battery, Negative
2:1	103-3895	1	Diode	11	3234-5	2	Screw-HHF
2:2	218-578	1	Fuse-Blade, 10 Amp	12	104-8300	2	Nut-HF, NI
2:3	109355	1	Fuse-Blade, 15 Amp	13	1-303287	3	Tie-Cable
2:4	109102	2	Fuse-Blade, 25 Amp	14	82-2190	1	Switch-Bail
2:5	116-0053	1	Cap-Plug	15	137-4100	1	Switch-Ignition
3	117-3882	1	Fuel/Hour Meter ASM	16	116-0124	1	Switch-PTO, 10 Amp
4	1-603511	1	Keys-Ignition (Spare Pair)	17	104-2065	1	Screw-HWH
4	103-2106	1	Key,Exmark Logo	18	115-3864	1	Cable-Battery, Positive
5	110-6765	2	Switch	19	3256-24	1	Washer-Flat
6	116-0042-03	1	Strap-Tie Down, Battery	20	3290-378	1	Tie-Cable
7	1-633651	2	Bolt-Holddown	22	109-2407	1	Insulator-Battery
8	1-543792	2	Wingnut	23	1-543393	1	Insulator-Solenoid
9	1-643275	1	Relay				

● Use dielectric grease on all unsealed connectors and terminals only. Do not apply in sealed connectors.

Notes:

Notes:

Notes:



MAXIMIZE THE PERFORMANCE OF YOUR EXMARK MACHINE.



EXMARK® PREMIUM ENGINE OIL

Exmark now offers a family of engine oil viscosities to perform well in any environment. Each viscosity has the same synthetic formulation to give you what you need in punishing conditions. We designed each grade to the highest quality, making it ideal even for diesel applications. Coupled with Exmark Premium Fuel Treatment, we have the performance products to make your machine hum.

EXMARK PREMIUM ENGINE OIL SAE 30/10W-30

- Meets zero shear requirements of a straight grade SAE 30 as well as the cold temp properties of a 10W-30.
- Most versatile oil in the industry.
- Superior corrosion protection over conventional oil - even in corrosive, humid environments.

EXMARK PREMIUM ENGINE OIL SAE 20W-50

- Perfect for your big block engine, or any application in severe service.
- Same full synthetic formulation as all other Exmark Premium viscosities.
- Also effective for use in severe service small block engines.

EXMARK PREMIUM ENGINE OIL SAE 10W-50

- Full synthetic formulation gives you peak performance. Don't settle for less.
- Wide span multi-grade combines easy starting in cold weather with maximum protection in high temperature operation.
- Reduce friction & wear over standard mineral formulations.

EXMARK PREMIUM ENGINE OIL SAE 0W-40

- The perfect choice for when the weather turns cold or unpredictable, and your Exmark UTV has to perform.
- Commercial quality for severe service.
- Advanced additive package helps prevent corrosion from long-term storage.

EXMARK PREMIUM ENGINE OIL UTV FORMULATION

- 4-cycle high-temp formulation.
- Heavier viscosity, full synthetic, perfect for your UTV.

EXMARK PREMIUM UTV EXTREME CONDITIONS GEAR OIL

- SAE 80W-90, designed to keep your UTV performing at its peak.
- Shear stable, hypoid gear lube.
- Includes a premium additive system to combat wear, oxidation, rust & corrosion.

Available from your local Exmark dealer. Find your closest dealer at exmark.com

EXMARK ACCESSORIES AND OPTIONS*

MID-MOUNT RIDING ACCESSORIES AND OPTIONS

CUSTOM RIDE SEAT SUSPENSION SYSTEM	OPERATOR CONTROLLED DISCHARGE
FULL SUSPENSION SEAT	SUN SHADE
DECK LIFT ASSIST KIT	TRASH CONTAINER
HITCH KIT	TURF STRIPER
LIGHT KIT	ULTRA VAC COLLECTION SYSTEM
12V POWER PORT	ULTRA VAC QUICK DISPOSAL SYSTEM
MICRO-MULCH SYSTEM	

OUT-FRONT RIDING ACCESSORIES AND OPTIONS

CUSTOM RIDE SEAT SUSPENSION SYSTEM	SNOW BLADE
DUAL-TAIL WHEEL	SNOWBLOWER
FLOOR PAN EXTENDER	SUN SHADE
HITCH KIT	TRASH CONTAINER
LIGHT KIT	ULTRA VAC COLLECTION SYSTEM
MICRO-MULCH SYSTEM	ULTRA VAC QUICK DISPOSAL SYSTEM
ROLL OVER PROTECTION SYSTEM (ROPS)	WEATHER CAB

WALK-BEHIND ACCESSORIES AND OPTIONS

GRASS CATCHER	TURF STRIPER
MICRO-MULCH SYSTEM	STANDON

*Some accessories and options not available for some models.

Place Model No. and Serial No.
Label Here (Included in the Literature
Pack) or Fill in Below

Model No. _____

Serial No. _____

Date Purchased _____

Engine Model No. and Spec. No. _____

Engine Serial No. (E/No) _____

© 2020 Exmark Mfg. Co., Inc.
415 Industrial Row
Beatrice, NE 68310
All Rights Reserved

Part No. 4505-441 Rev. A
(402) 223-6375
Fax (402) 223-5489
Printed in the USA.

