

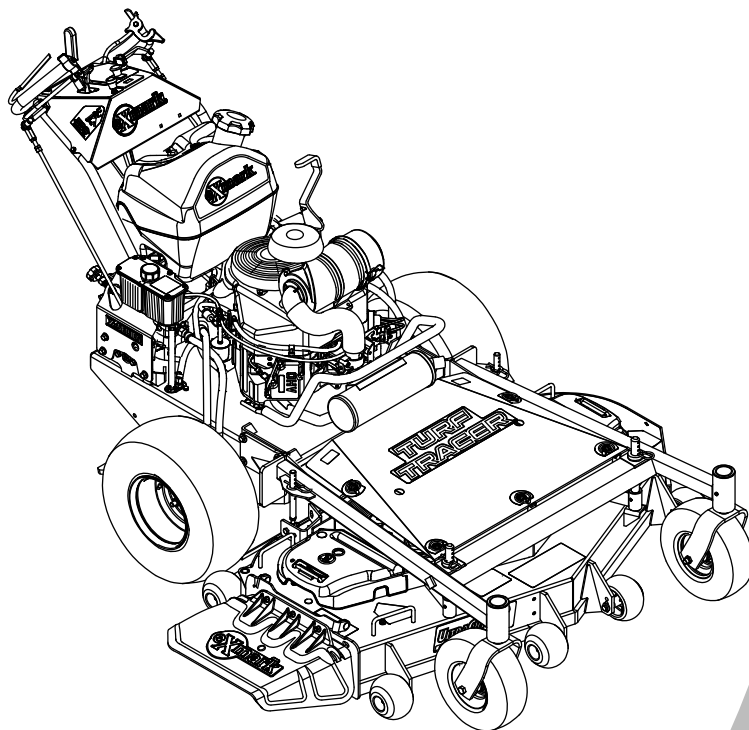

# **TURF TRACER® X-SERIES**

Model No. TTX691CKA52400—Serial No. 408644346 and Up

Picture below may not reflect actual product.



# Parts Manual

Part No. 4505-412 Rev. A

# Ordering Replacement Parts

To order replacement parts, please supply the part number, the quantity, and the description of each part desired.

## Understanding Reference Numbers

Each identified part in an illustration has a reference number. The reference number for a part also appears in the parts list, along with other information about the part.

This catalog uses two special reference number formats, one to indicate parts in a service assembly and another to indicate the quantity of a given part in an illustration.

## Service Assembly Reference Numbers

Parts in service assemblies have reference numbers in the form a:b. The a represents the reference number of the entire service assembly and the b represents a sequential number unique to each part within the service assembly.

For example, a wheel assembly might be identified by reference number 6, the tire by 6:1, the valve by 6:2, and the wheel by 6:3. When you order the assembly identified by reference number 6, you receive all parts identified by reference numbers 6:1, 6:2, and 6:3. However, you may also order any part individually. Reference numbers of this type appear in illustration and in parts lists.

## Reference Numbers Indicating Quantity

In an illustration, if a reference number indicates more than one part, the reference number has the form nX y. The n represents the quantity of the part, the X is the multiplication symbol, and the y represents the reference number.

For example, in an illustration, the reference number 2X 37 means that two of the parts identified by reference number 37 are indicated.

# Touch Up Paint

Exmark black touch up spray paint – gloss black.

Exmark red touch up paint (spray paint – P/N 1-850337 - .6 oz liquid bottle – P/N 103-9140).



If your Exmark dealer does not have the Exmark part in stock, Exmark will get the parts to the dealer the next business day or the part will be FREE Guaranteed!! (Some restrictions apply. See your participating Exmark Dealer for details.)

## Contents

Complete Deck Assembly.....	4
Deck Assembly.....	6
Deck W/Decals.....	8
Deck Idler Assembly No. 126-2314.....	10
Frame Assembly.....	12
Front Frame Assembly.....	14
Handle Assembly.....	16
Controls Assembly.....	18
Engine Deck Assembly.....	20
Engine Assembly.....	22
Fuel Assembly.....	24
Hydro Assembly.....	26
Electrical Assembly.....	28

# Complete Deck Assembly

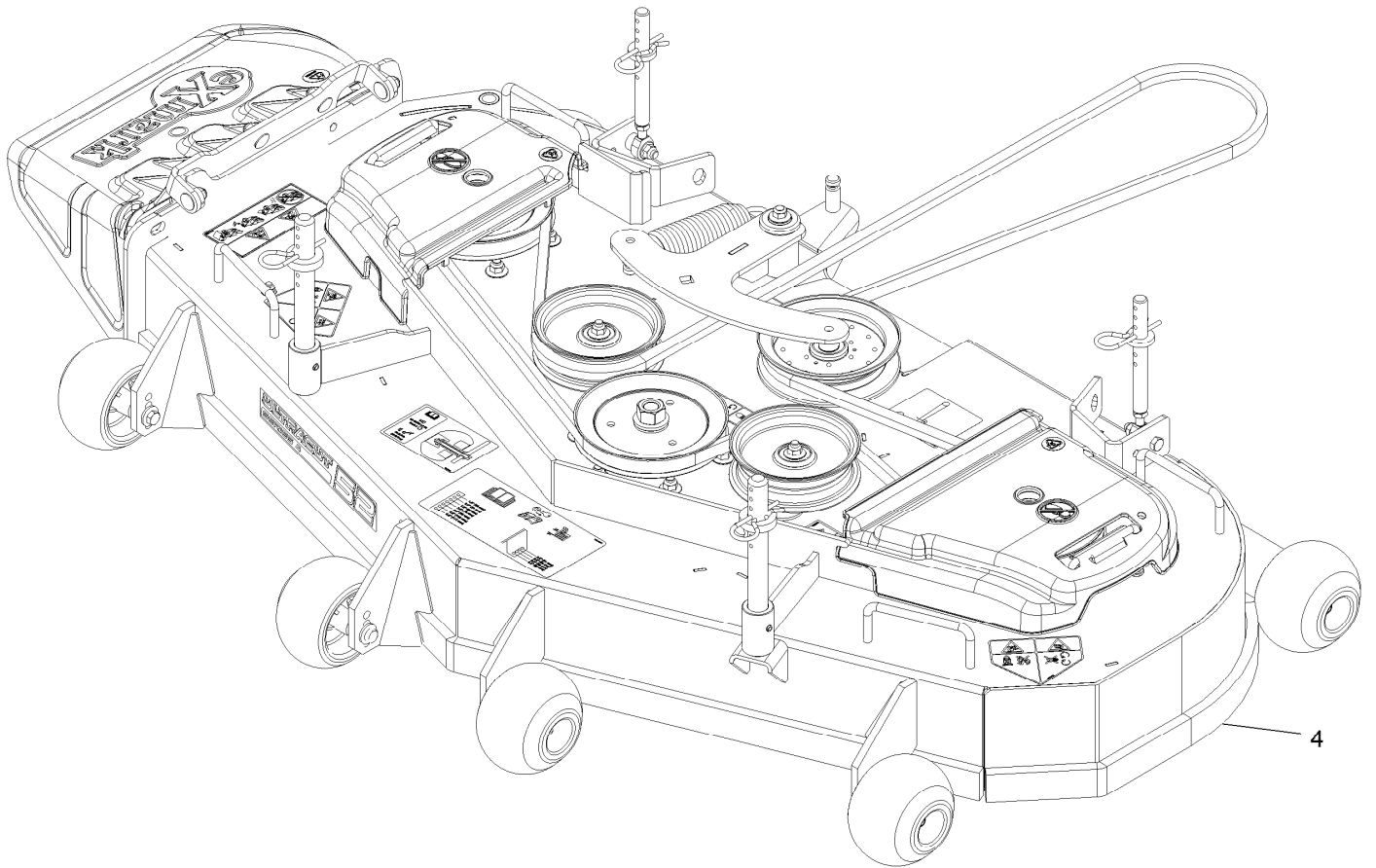

# Complete Deck Assembly (continued)

<i>Ref.</i>	<i>Part Number</i>	<i>Qty.</i>	<i>Description</i>
4	126-2536	1	ASM, Complete Deck, 52

# Deck Assembly

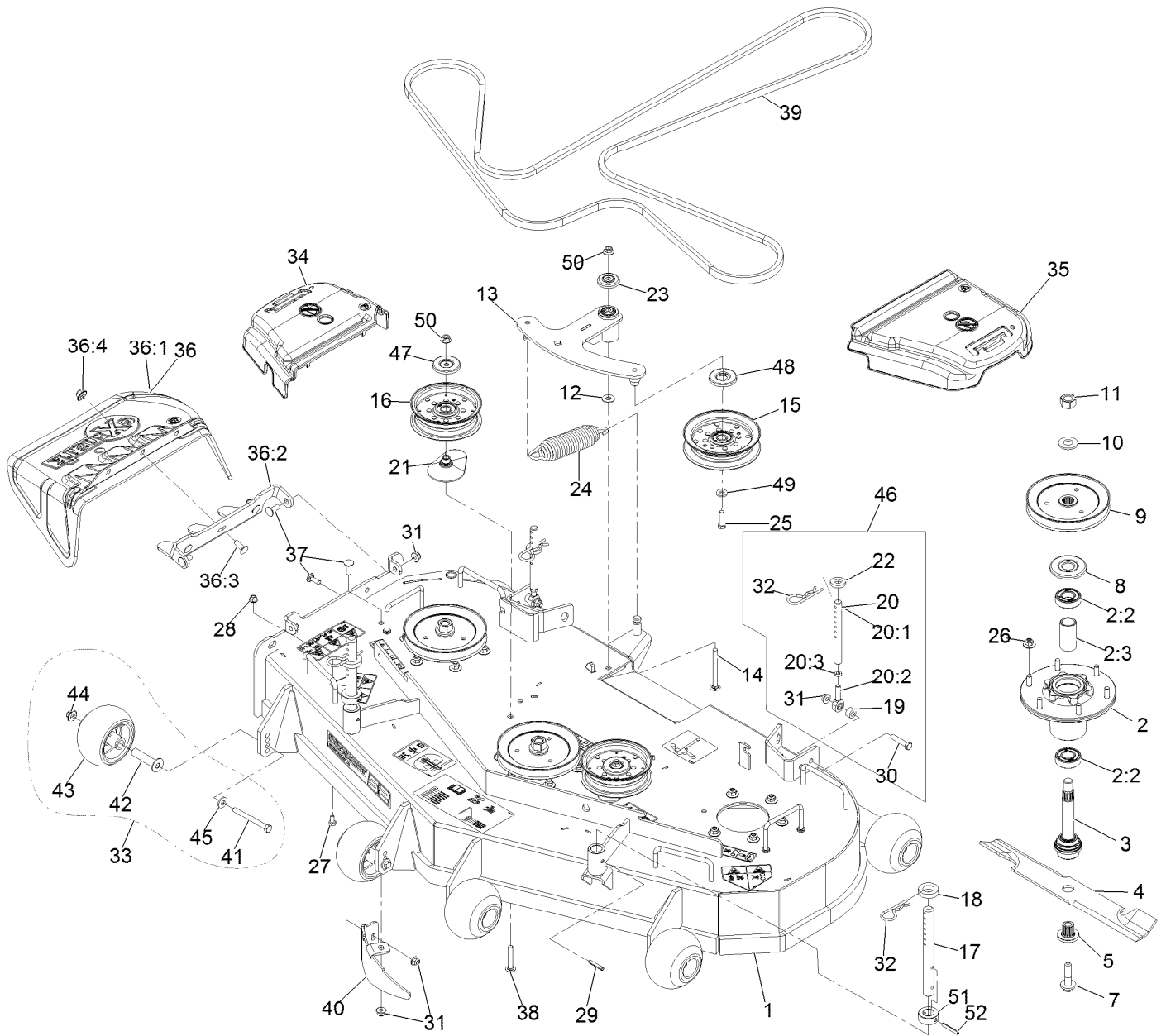

## Deck Assembly (continued)

Ref.	Part Number	Qty.	Description	Ref.	Part Number	Qty.	Description
1	126-2472	1	ASM, Deck W/ Decals, 52"	25	323-7	1	Screw-HH
2	116-3344	3	ASM-Cutter Hsg With Bearings	26	109-6658	18	Nut-Flange, NI
2:2	116-0720	2	Bearing-Ball	27	322-2	1	Screw-HH
2:3	116-3312	1	Spacer-Bearing	28	104-8300	1	Nut-HF, NI
3	116-3341	3	ASM-Spindle And Seal □	29	1-806332	2	Roll Pin, 1/4 X 1-1/2
4	116-5175	3	Blade-Extreme 2, 18.00" ●	30	323-9	2	Screw-HH
4	103-6402	3	Blade-Notched	31	104-8301	6	Nut-HF, NI
4	103-6392	3	Blade, Mulching ◆	32	1-806009	4	Hairpin, .177
4	103-6387	3	Blade, Low Lift ●	33	116-9981	6	Kit, Anti-Scalp Roller
4	103-6382	3	Blade, Solid ●	34	109-6935	1	Cover-Belt, RH
5	103-3037	3	Bushing, Splined	35	109-6936	1	Cover-Belt, LH
7	109-9220	3	Screw-Sems ■ ○	36	109-7188	1	ASM,Discharge Chute
8	116-1286	3	Guard,Bearing Top .989	36:1	109-2738	1	Chute, Discharge
9	116-0675	3	Sheave,Blade Drive 6.50	36:2	109-8675-01	1	Bracket,Discharge Chute
10	103-2802	3	Washer	36:3	3231-22	3	Screw-CARR
11	116-7306	3	Nut-Hex ▲	36:4	109-6658	3	Nut-Flange, NI
12	3256-4	1	Washer-Flat	37	3231-22	4	Screw-CARR
13	126-2314	1	ASM, Deck Idler	38	3231-40	2	Bolt-CARR
14	3231-24	1	Screw-CARR	39	126-2538	1	Belt-Drive, Deck
15	126-9196	1	Idler-Pulley, Flat	40	116-5814-01	1	Baffle-Dogleg, Lz-Vt52
16	126-9197	2	Idler-Pulley, Flat 5.00X1.31	41	116-9362	6	Screw-HH
17	135-4829	2	Rod, Deck Support	42	116-8131	6	Axle, Roller
18	1-413425	2	Spacer-Deck Support	43	103-8415	6	Roller-Anti-Scalp
19	1-603050	2	Spacer	44	109-6658	6	Nut-Flange, NI
20	1-414521	2	Link Assy	45	98-5975	6	Washer-Belleville
20:1	1-413525	1	Link, Rear Deck Support	46	1-411532	2	Kit, Support Link W/Pin
20:2	1-613204	1	Balljoint	47	126-8043	2	Shield-Dust
20:3	3220-3	1	Nut-HJ	48	126-9195	1	Shield-Guard, Dust
21	109-2872	2	Spacer-Pulley	49	43-0940	1	Spacer
22	1-323539	2	Spacer	50	32128-19	3	Nut-HF Lock, Large Flg
23	103-2916	1	Guard-Top	51	135-4828	2	Collar, Deck Height Pin
24	116-6317	1	Spring-Extension	52	32121-32	2	Pin-Roll

● Optional Equipment

▲ Torque to 130-160 ft-lb

◆ Requires installation of mulch kit for proper mulching. See your Exmark dealer for details.

□ Apply Mobil HTS grease (P/N 103-5217 1.5 oz packet) (or a food-grade anti-seize). See operator s manual for locations.

○ Apply lubricant to threads as needed to prevent seizing. Copper based anti-seize preferable. Grease is an acceptable substitute.

■ Torque to 50-60 ft-lb

# Deck W/Decals

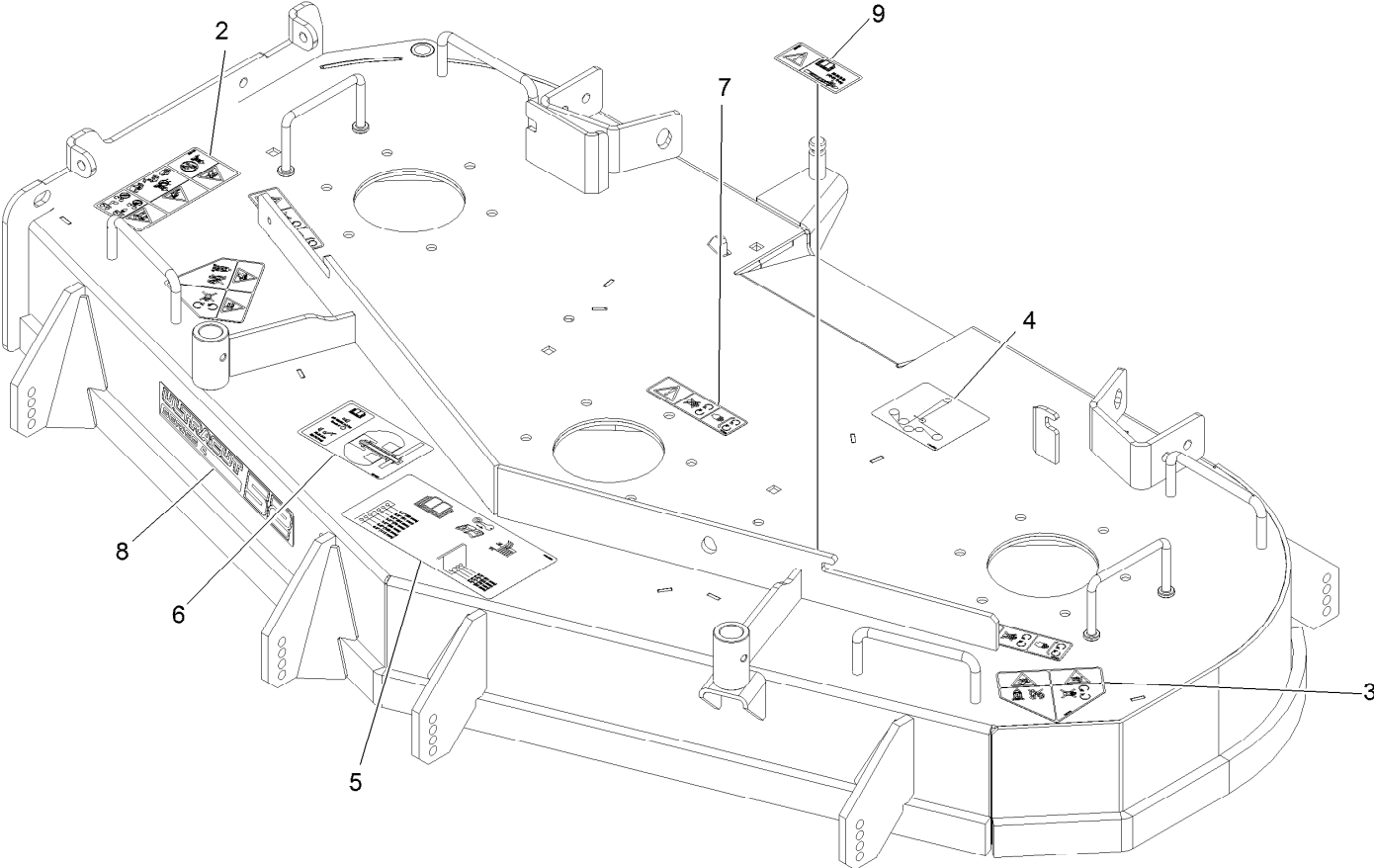



## Deck W/Decals (continued)

<i>Ref.</i>	<i>Part Number</i>	<i>Qty.</i>	<i>Description</i>	<i>Ref.</i>	<i>Part Number</i>	<i>Qty.</i>	<i>Description</i>
2	135-5210	1	Decal-Warning Thrown Obj	6	126-0898	1	Decal-Roller Mounting
3	112-8760	2	Decal-Danger	7	112-9028	3	Decal-Cover, Missing
4	116-8727	1	Decal-Belt Routing	8	126-6588	1	Decal, 524
5	116-8278	1	Decal-Anti-Scalp	9	116-8283	1	Decal-Torque, Bolt

# Deck Idler Assembly No. 126-2314

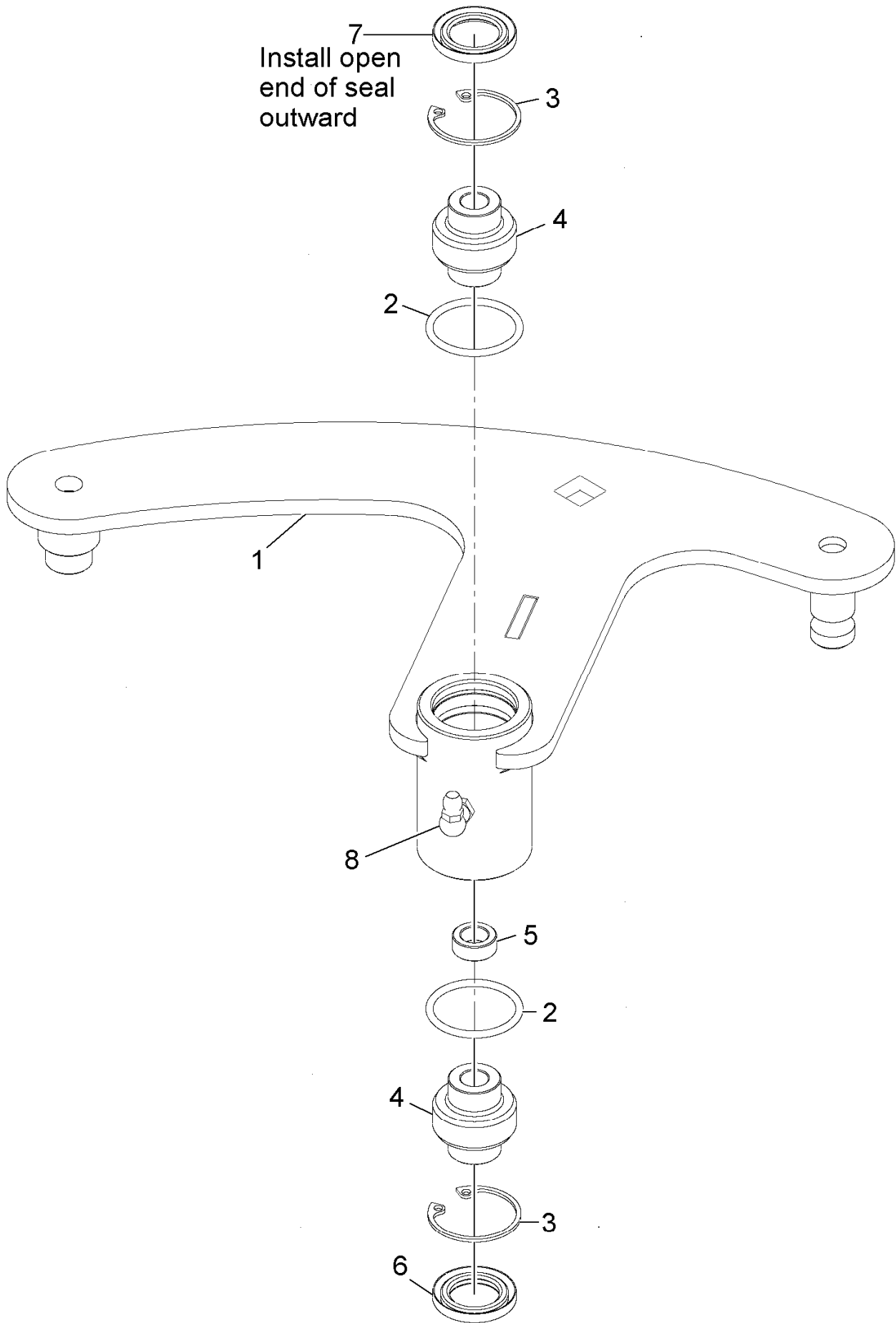

## Deck Idler Assembly No. 126-2314 (continued)

<i>Ref.</i>	<i>Part Number</i>	<i>Qty.</i>	<i>Description</i>	<i>Ref.</i>	<i>Part Number</i>	<i>Qty.</i>	<i>Description</i>
1		1	Weld, Idler Arm ●	5	103-5677	1	Spacer
2	106-7159	2	O-Ring	6	103-3505	1	Seal-Lip, Double
3	32120-10	2	Ring-Snap	7	103-3506	1	Seal-Lip, Single
4	103-3504	2	Bearing-Spherical	8	302-40	1	Fitting-Grease, 90 DEG

● Not serviced separately

# Frame Assembly

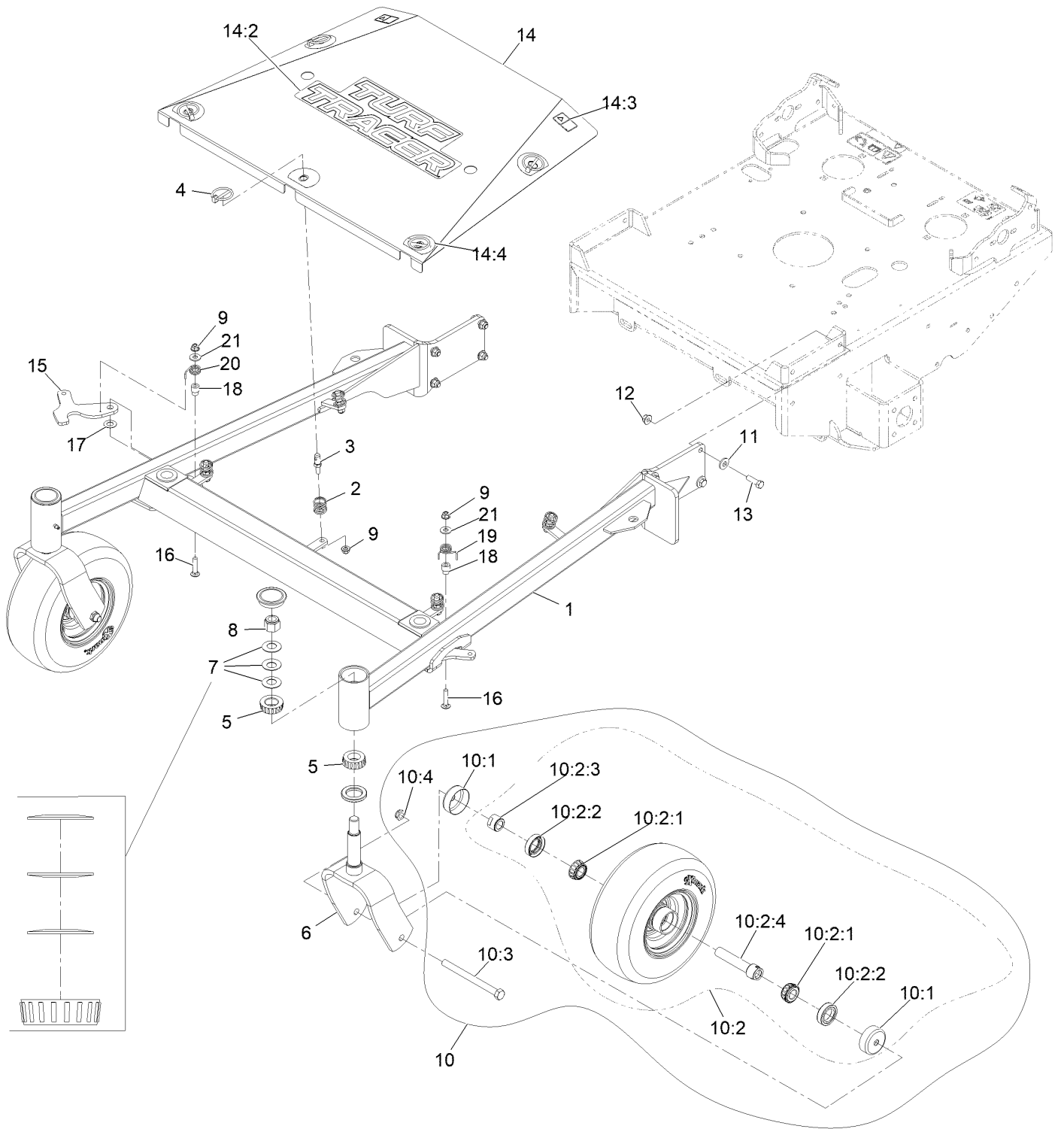

## Frame Assembly (continued)

<i>Ref.</i>	<i>Part Number</i>	<i>Qty.</i>	<i>Description</i>	<i>Ref.</i>	<i>Part Number</i>	<i>Qty.</i>	<i>Description</i>
1	126-2540	1	ASM, Front Frame W/ Bearings, 52	10:3	325-20	1	Screw-HH 1/2-13 X 6
2	126-1503	5	Spring	10:4	3296-45	1	Nut-Nyloc 1/2-13 Thin
3	135-7455	5	Pin, Spring	11	98-5975	8	Washer-Spring Disc 3/8
4	92-1298	5	Pin-Lynch	12	104-8301	8	Nut-Nyloc 3/8-16 Flg
5	1-543509	4	Cone-Bearing Tapered Roller	13	323-7	8	Screw-HH 3/8-16 X 1 1/4
6	103-1891-01	2	Wld, Caster Fork	14	126-2544	1	ASM, Center Shield W/ Decals, 52
7	1-633508	6	Washer-Spring Disc	14:2	126-6892	1	Decal-Turf Tracer
8	3296-51	2	Nut-Nyloc 3/4-10	14:3	106-5517	2	Decal-Warning
9	104-8300	7	Nut-Nyloc 5/16-18 Flg	14:4	126-1692	5	Decal-Scratch Cover
10	109-3524	2	Asm, Wheel And Bearings	15	135-4827-01	2	Latch, Deck Height
10:1	103-2768	2	Guard-Seal	16	3230-4	2	Bolt-Carriage 5/16-18 X 1 1/2
10:2		1	Wheel And Bearing ASM ●	17	110-4068	2	Washer-Plastic
10:2:1	1-633585	2	Bearing-Cone Tapered Roller	18	108-9087	2	Collar-Basket
10:2:2	103-0063	2	Seal-Double Lip	19	75-3960	1	Spring-Torsion, LH (Yellow)
10:2:3	103-3051	1	Spacer-Nut	20	75-3970	1	Spring-Torsion, RH
10:2:4	126-5359	1	Caster Axle ASM	21	3256-3	2	Washer-5/16 Std

● Not serviced separately

# Front Frame Assembly

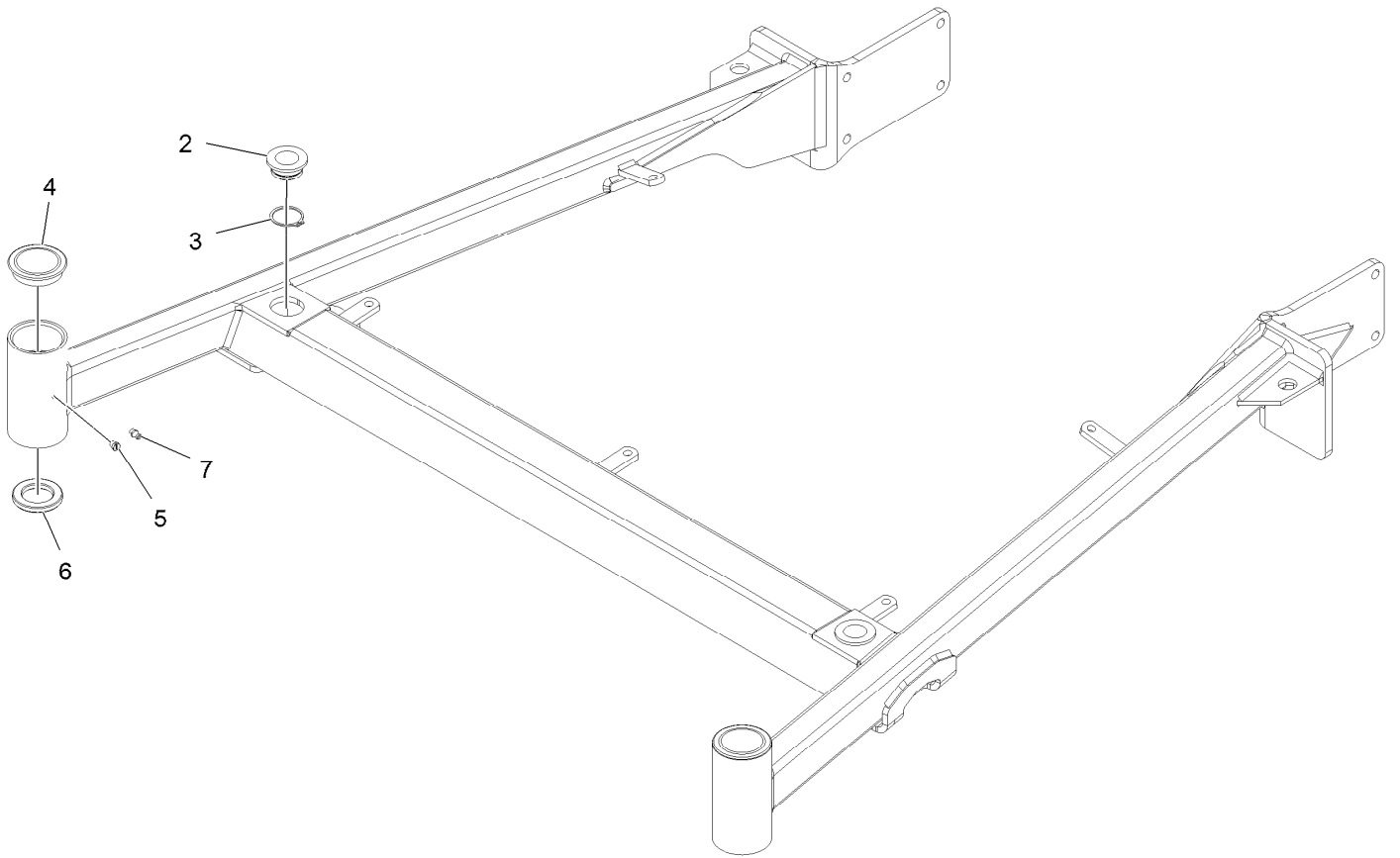

## Front Frame Assembly (continued)

<i>Ref.</i>	<i>Part Number</i>	<i>Qty.</i>	<i>Description</i>	<i>Ref.</i>	<i>Part Number</i>	<i>Qty.</i>	<i>Description</i>
2	1-513336	2	Bushing-Deck	5	1-811010	2	Plug
3	32120-33	2	Ring-Retaining	6	1-543511	2	Seal-Grease
4	103-4882	2	Cap-Grease	7	302-19	1	Zerk-1/4-28 Str

# Handle Assembly

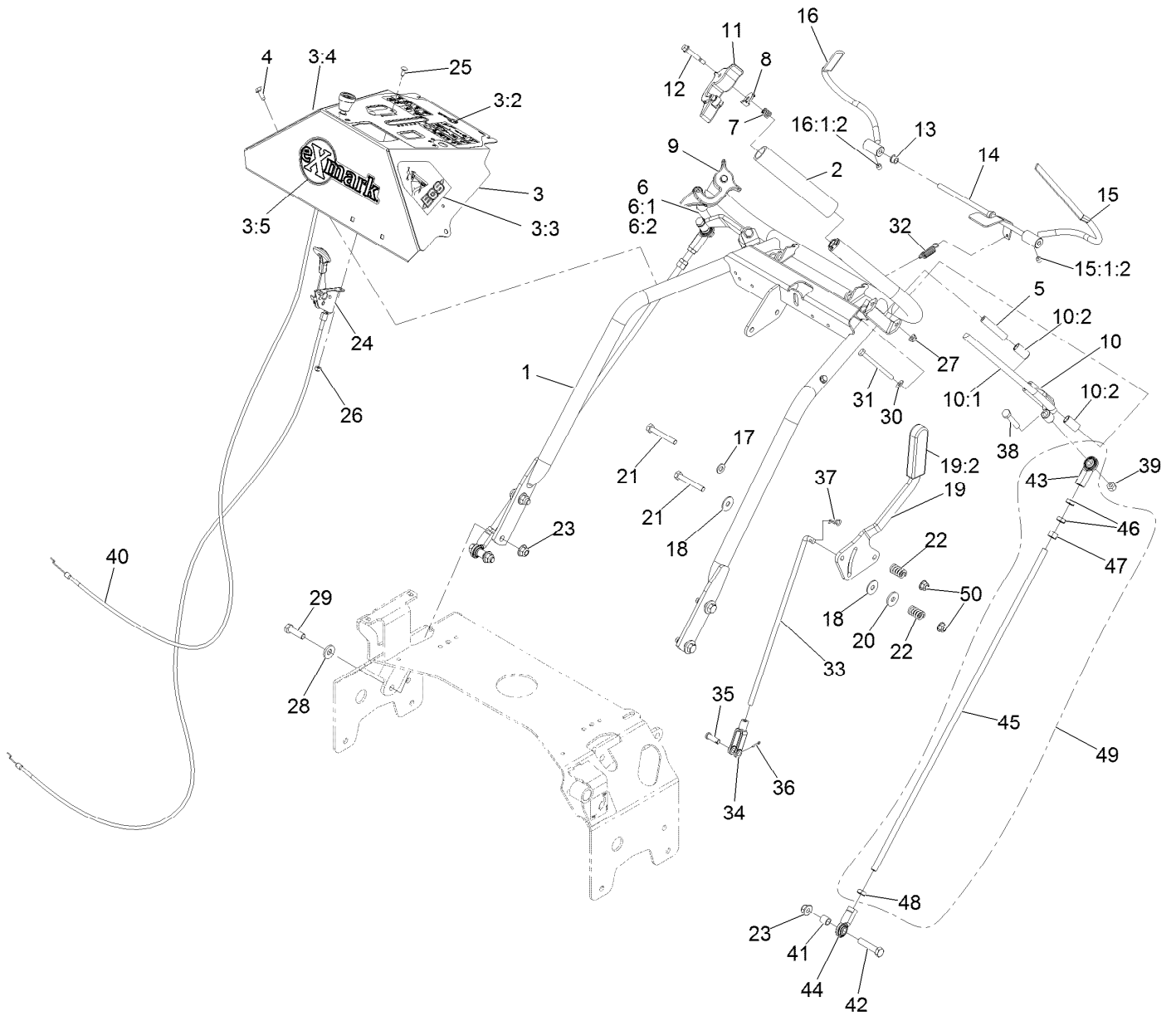



## Handle Assembly (continued)

<i>Ref.</i>	<i>Part Number</i>	<i>Qty.</i>	<i>Description</i>	<i>Ref.</i>	<i>Part Number</i>	<i>Qty.</i>	<i>Description</i>
1	126-2642-03	1	Weld, Handle	21	322-11	2	Screw-HH 5/16-18 X 2 1/4
2	103-0815	2	Grip-Bar, Handle	22	1-323245	2	Spring-Compression
3	126-3541	1	ASM, Console W/ Decals	23	104-8301	6	Nut-Nyloc 3/8-16 Flg
3:2	135-2863	1	Decal-Console	24	109-3958	1	Control-Throttle
3:3	103-2242	1	Decal, Ecs Instruction LH	25	1-807513	2	Bolt-Carriage #10-24 X 1/2
3:4	103-2243	1	Decal, Ecs Instruction RH	26	3296-2	2	Nut-Nyloc #10-24
3:5	126-6877	1	Decal, Exmark Logo	27	104-7201	2	Nut-Nyloc 1/4-20 Flg
4	32144-10	2	Screw-HWH 1/4-20 X .62	28	98-5975	4	Washer-Spring Disc 3/8
5	103-0027	2	Bushing-Lever, Drive	29	323-7	4	Screw-HH 3/8-16 X 1 1/4
6	103-2513	1	Asm, Drive Lever RH	30	3256-22	2	Washer-1/4 SAE
6:1	116-4082	1	Wld,RH Drive Lever	31	321-14	2	Screw-HH 1/4-20 X 2 3/4
6:2	126-9366	2	Bushing, Sleeve	32	1-303363	1	Spring-Extension
7	1-633349	2	Spring-Compression	33	1-413225	1	Rod, Speed Control
8	126-2921	2	Latch, Ecs	34	1-303105	1	Yoke-Adjustable
9	103-1371	1	Thumb Latch Asm RH	35	1-808280	1	Pin-Clevis 5/16 X 1 49/64
10	103-2514	1	Asm, Drive Lever LH	36	3272-5	1	Pin-Cotter 3/32 X 1/2
10:1	116-4081	1	Wld,LH Drive Lever	37	1-806003	1	Hairpin-Cotter
10:2	126-9366	2	Bushing, Sleeve	38	322-9	2	Screw-HH 5/16-18 X 1 3/4
11	103-1372	1	Thumb Latch Asm LH	39	3296-29	2	Nut-Nyloc 5/16-18
12	126-2931	2	Screw-Shoulder	40	126-2107	1	Cable, Choke
13	1-303365	2	Bushing-Nylon	41	103-1166	2	Spacer-Tube, Pump Link
14	103-0769-03	1	Rod Weldment, OPC	42	323-9	2	Screw-HH 3/8-16 X 1 3/4
15	116-4079	1	Wld,LH OPC Lever ■	43	103-2463	4	Balljoint
15:1:2	1-803322	1	Setscrew-5/16-24 X 5/16 ●	44	103-1167	2	Joint-Ball End
16	116-4080	1	Wld,RH OPC Lever ■	45	103-1148	2	Rod,Drive Lever
16:1:2	1-803322	1	Setscrew-5/16-24 X 5/16 ●	46	3220-3	4	Nut-Jam 3/8-24
17	3256-23	1	Washer-5/16 SAE	47	3219-3	2	Nut-Hex 3/8-24
18	1-323244	2	Washer-Friction	48	3220-16	2	Nut-Jam 3/8-24 LH
19	126-0148	1	Lever, Shift W/Grip	49	116-3414	2	Drive Link ASM
19:2	103-5994	1	Grip-Handle, Steering	50	104-8300	2	Nut-Nyloc 5/16-18 Flg
20	1-603716	1	Washer-Friction Disc				

● Use Pro-Lock, Nut Type (P/N 1-840022, .5ml tube) on threads.

■ Use Pro-Lock retaining type, Part no. 1-840023 (.5cc tube) on inside of bore of OPC hub.

# Controls Assembly

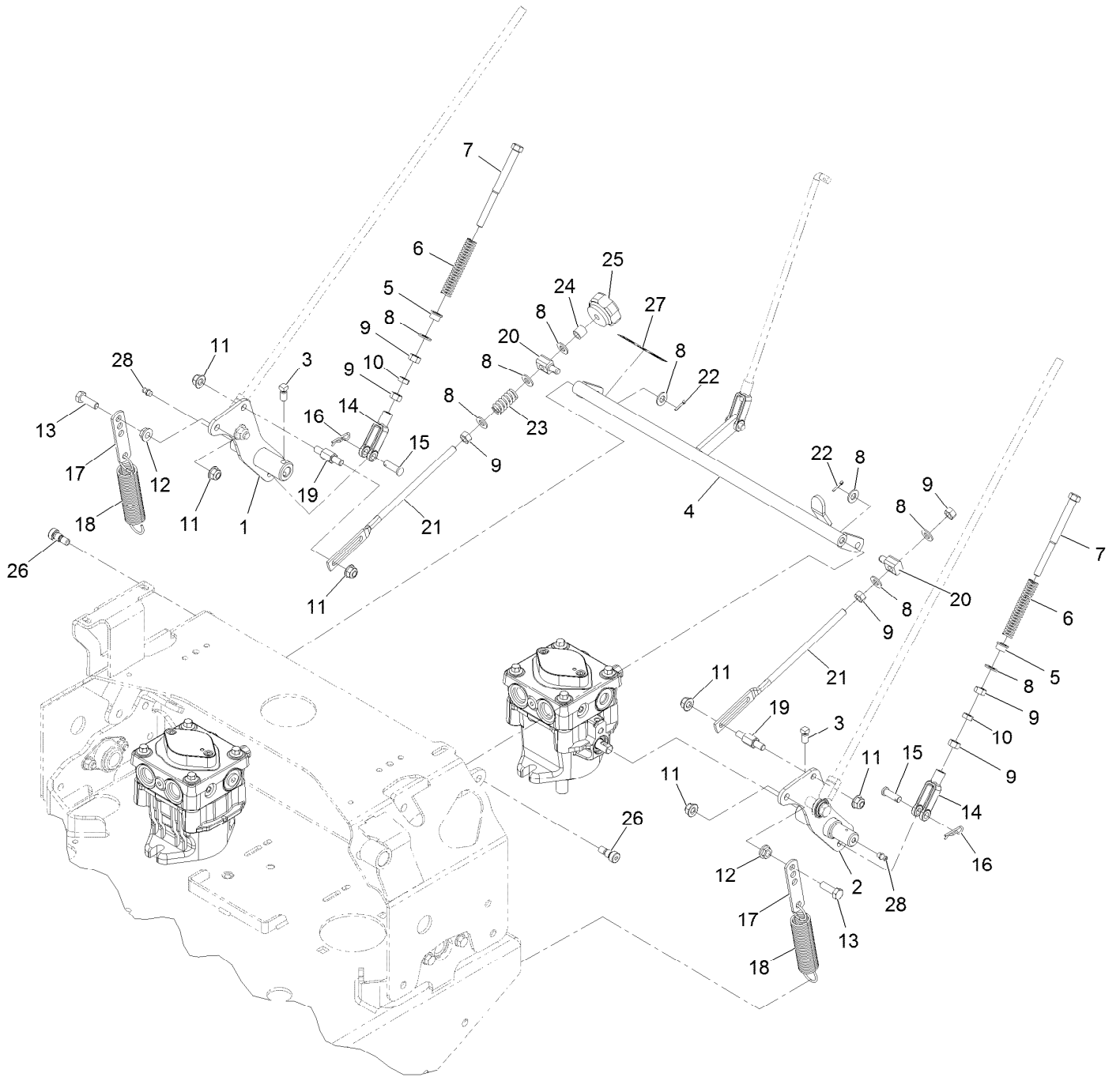

## Controls Assembly (continued)

<i>Ref.</i>	<i>Part Number</i>	<i>Qty.</i>	<i>Description</i>	<i>Ref.</i>	<i>Part Number</i>	<i>Qty.</i>	<i>Description</i>
1	116-9975	1	Weld, Motion Control, Rt	15	1-808280	2	Pin-Clevis 5/16 X 1 49/64
2	116-9974	1	Weld, Motion Control, Lt	16	1-806003	2	Hairpin-Cotter
3	1-803022	2	Setscrew-5/16-18 X 5/8	17	1-613089	2	Tab-Spring, Extension
4	126-2982-01	1	Weld, Speed Control	18	1-603693	2	Spring
5	1-603735	2	Bushing-Flanged	19	126-0610	2	Pin, Motion Control
6	103-0265	2	Spring, Neutral Return	20	126-8571	2	Swivel-Adjustable, Short
7	1-603737	2	Bolt-Neutral Return	21	1-413350	2	Link-Control, Speed
8	3256-23	9	Washer-5/16 SAE	22	3272-5	2	Pin-Cotter 3/32 X 1/2
9	3219-2	7	Nut-Hex 5/16-24	23	1-323245	1	Spring-Compression
10	3220-2	2	Nut-Jam 5/16-24	24	1-603903	1	Spacer
11	104-8300	6	Nut-Nyloc 5/16-18 Flg	25	103-3060	1	Knob-Tracking
12	32128-20	2	Nut-Whizlock 5/16-18	26	1-809056	2	Screw-Sh 5/16-18 X 1 3/8
13	322-5	2	Screw-HH 5/16-18 X 1	27	116-7918	1	Decal-Tracking Adjustment
14	1-303105	2	Yoke-Adjustable	28	302-19	2	Zerk-1/4-28 Str

# Engine Deck Assembly

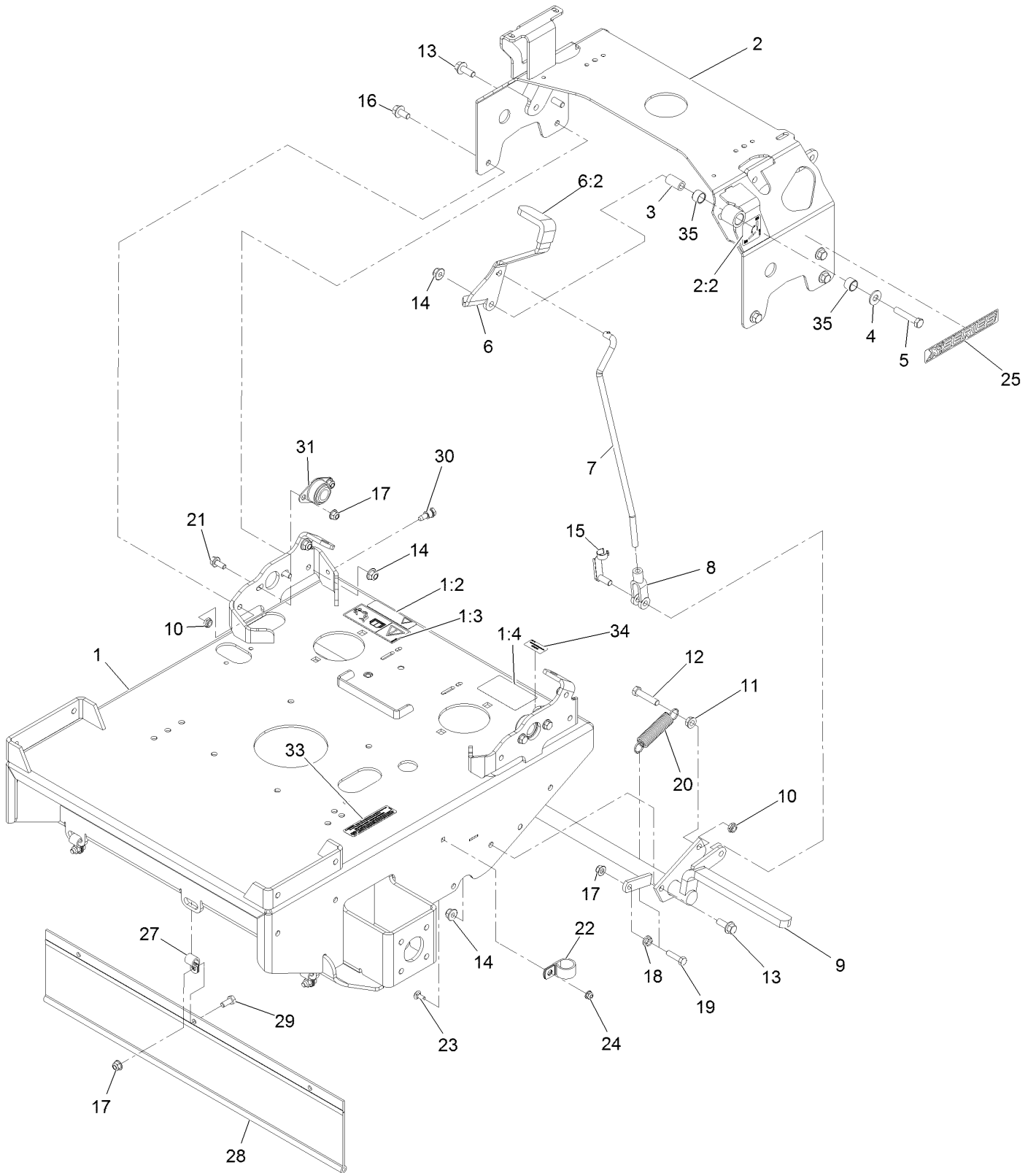

## Engine Deck Assembly (continued)

<i>Ref.</i>	<i>Part Number</i>	<i>Qty.</i>	<i>Description</i>	<i>Ref.</i>	<i>Part Number</i>	<i>Qty.</i>	<i>Description</i>
1	126-2521	1	ASM, Engine Deck W/ Decals	15	103-2399	1	Pin-Clevis Spring 3/8
1:2	98-1977	1	Decal-Warning	16	3234-12	2	Screw-HH Flg 3/8-16 X 3/4
1:3	126-1400	1	Decal-Warning, Sulky	17	104-8300	8	Nut-Nyloc 5/16-18 Flg
1:4	116-8253	1	Decal-Drive Release	18	32128-20	1	Nut-Whizlock 5/16-18
2	126-2181	1	ASM, Tank Support W/ Decal	19	322-6	1	Screw-HH 5/16-18 X 1 1/4
2:2	116-5988	1	Decal-Park Brake, CE	20	1-323161	1	Spring
3	1-413344	1	Bushing-Pivot	21	3234-47	4	Screw-HH Flg 5/16-18 X 3/4
4	3256-4	1	Washer-3/8 Std	22	1-643312	1	Clip-Loom
5	323-10	1	Screw-HH 3/8-16 X 2	23	3229-11	1	Bolt-Carriage 1/4-20 X 5/8
6	126-2180	1	ASM, Brake Lever W/ Grip	24	104-7201	1	Nut-Nyloc 1/4-20 Flg
6:2	1-303020	1	Grip-Lever	25	126-6573	2	Decal-X-Series
7	116-9960	1	Linkage-Brake	27	1-413510	3	Clip-Loom
8	1-633131	1	Yoke-Linkage, Brake	28	103-2224	1	Shield, Drag
9	116-9159	1	Wld,Brake Ttx	29	322-3	3	Screw-HH 5/16-18 X 3/4
10	3296-59	3	Nut-Nyloc 3/8-16 Thin	30	115-1958	1	Bolt-Shoulder
11	3290-357	1	Nut-Whizlock 3/8-16	31	1-633102	2	Bearing-Flanged
12	323-9	1	Screw-HH 3/8-16 X 1 3/4	33	133-8062	1	Decal-Arrestor, Spark
13	3234-42	7	Screw HHF 3/8-16 X 1	34	126-4345	1	Decal-Patent
14	104-8301	8	Nut-Nyloc 3/8-16 Flg	35	1-413347	2	Sleeve-Bushing

# Engine Assembly

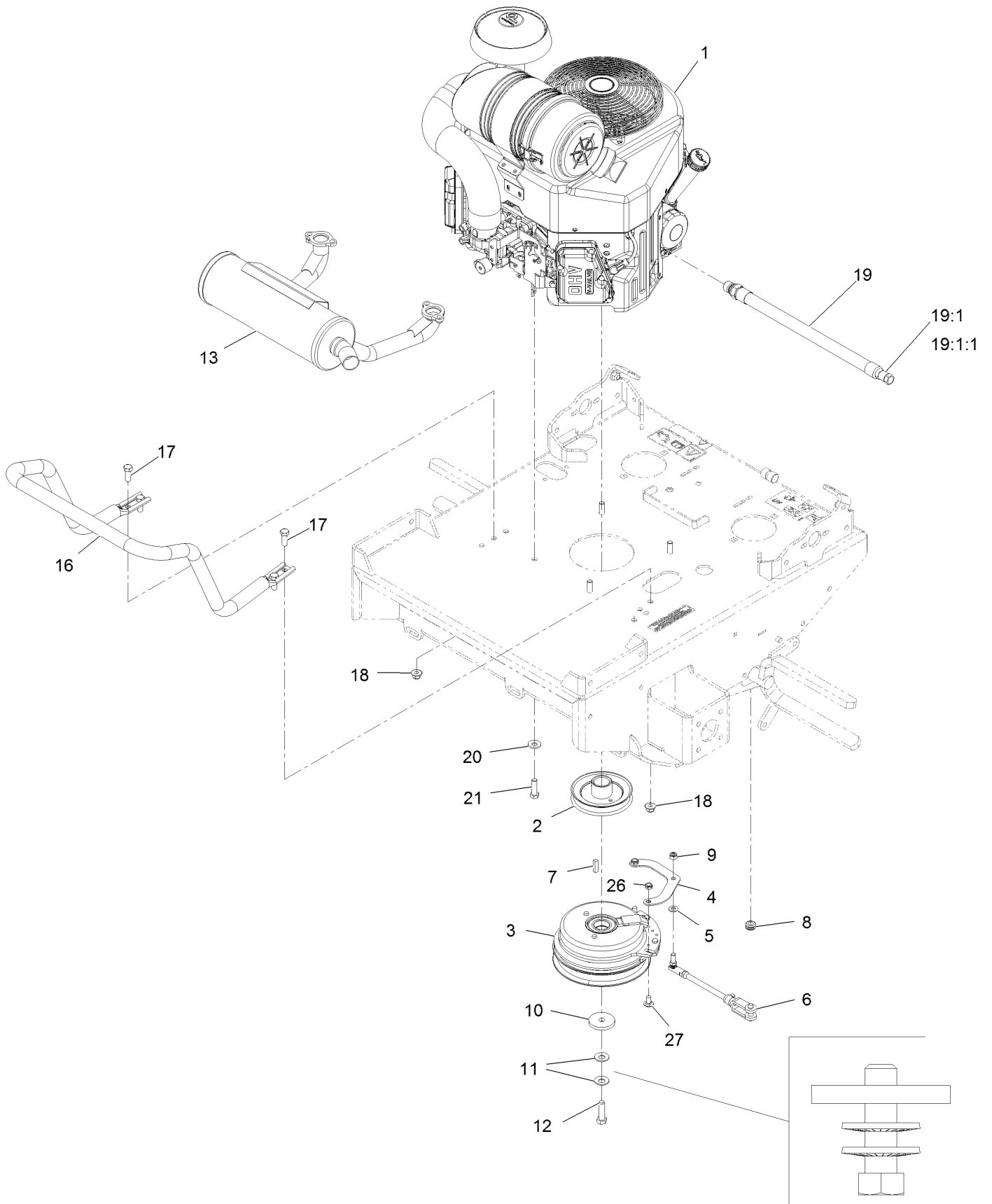

## Engine Assembly (continued)

<i>Ref.</i>	<i>Part Number</i>	<i>Qty.</i>	<i>Description</i>	<i>Ref.</i>	<i>Part Number</i>	<i>Qty.</i>	<i>Description</i>
1		1	Engine, Kaw Fx691 ▲◆	13	116-3736	1	Muffler,Horizontal
2	126-2605	1	Sheave W/ Hub	16	135-4729-03	1	Tube-Guard Muffler
3	126-2601	1	Clutch, 200 Ft/Lbs, 1.13	17	323-6	4	Screw-HH 3/8-16 X 1
4	126-2602	1	Strap, Clutch	18	104-8301	4	Nut-Nyloc 3/8-16 Flg
5	3256-23	1	Washer-5/16 SAE	19	116-5052	1	Asm-Oil Drain Hose W/Plug □●
6	126-0620	1	ASM, Clutch Anchor	19:1	353-508	1	Plug-W/O-Ring ■
7	1-807259	1	Key-Machine 1/4 X 1/4 X 1 ▶	19:1:1	237-42	1	O-Ring
8	237-136	1	Grommet	20	98-5975	4	Washer-Spring Disc 3/8
9	3296-4	1	Nut-Lock 5/16-24	21	323-7	4	Screw-HH 3/8-16 X 1 1/4
10	109-6919	1	Washer-Clutch	26	3296-47	2	Nut-Nyloc 5/16-18 Thin
11	1-603610	2	Washer-Spring Disc 7/16	27	3230-18	2	Bolt-Carriage 5/16-18 X 5/8
12	87-2080	1	Bolt-Hex, TAP ○				

● Torque to 23-29 ft-lb

▲ Not serviced separately

□ Use a Teflon Pipe Sealant or equivalent on threads.

○ Use Pro-Lock, Nut Type (P/N 1-840022, .5ml tube) on threads.

▶ Apply anti-seize compound to engine crankshaft, pulley hub I.D., clutch bore I.D. and square key.

■ Torque to 20-24 ft-lb

◆ Obtain parts from [www.kawpower.com](http://www.kawpower.com)

# Fuel Assembly

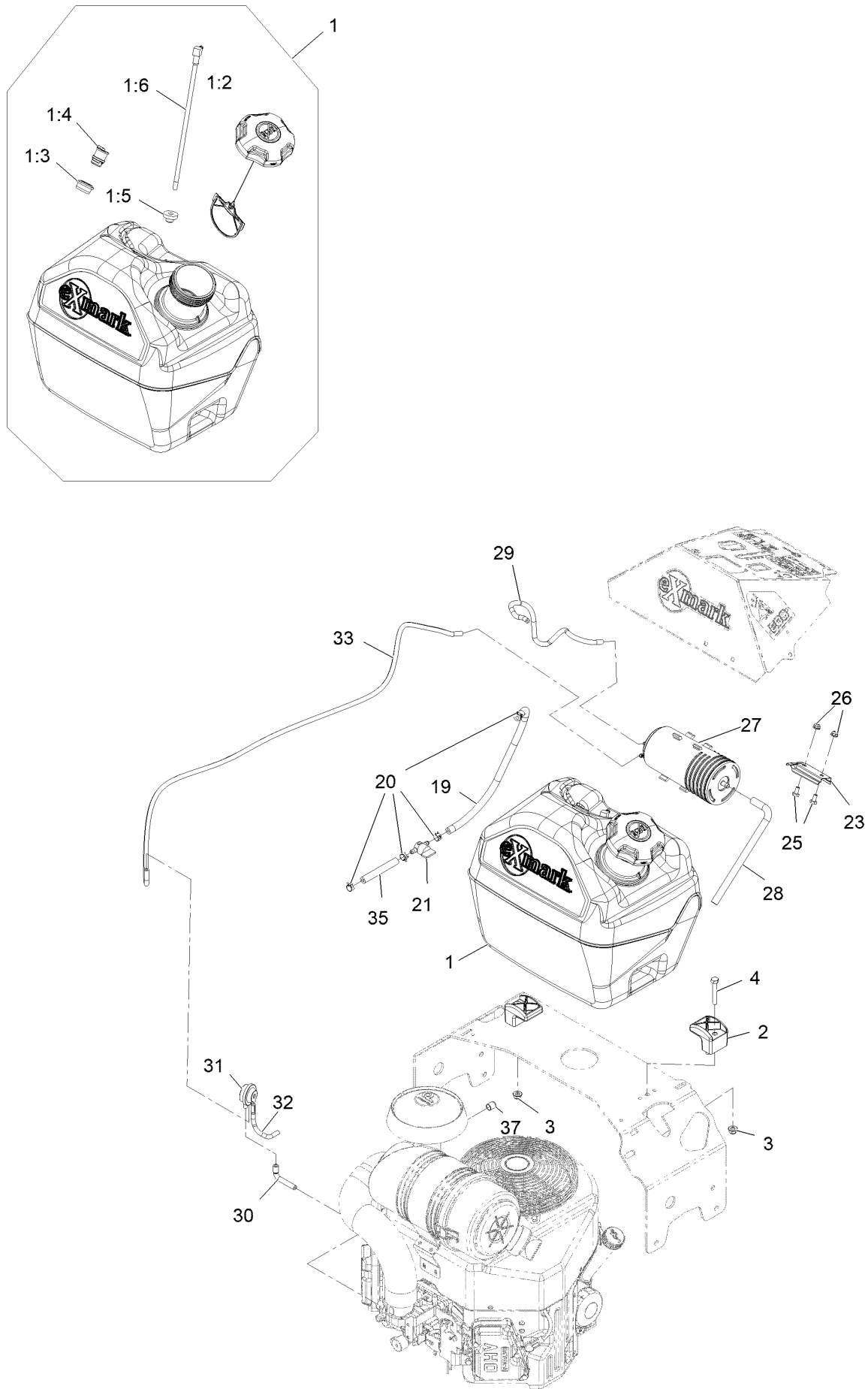



## Fuel Assembly (continued)

<i>Ref.</i>	<i>Part Number</i>	<i>Qty.</i>	<i>Description</i>	<i>Ref.</i>	<i>Part Number</i>	<i>Qty.</i>	<i>Description</i>
1	135-2855	1	ASM, Fuel Tank 5 Gal	23	114-0292	1	Bracket-Canister, Carbon
1:2	137-4119	1	Cap-Fuel, Ratcheting	25	321-2	2	Screw-HH
1:3	114-0284	1	Grommet	26	104-7201	2	Nut-HF
1:4	119-3547	1	Valve-Vent, Fuel	27	117-1221	1	Canister-Carbon, 800Cc
1:5	46-6560	1	Bushing	28	115-0962	1	Hose-Vent, Canister
1:6	109-9364	1	Fitting-Fuel (W/Line And Screen)	29	116-4801	1	Hose-Emissions
2	107-4543	2	Clamp	30	116-2233	1	Hose-Vent, Formed
3	104-8300	2	Nut-HF, NI	31	116-2232	1	Valve-Control, Vacuum
4	322-10	2	Screw-HH	32	116-2394	1	Hose-Vent, Formed
19	114-4428	1	Hose-Fuel	33	116-3116	1	Hose-Vent, Formed
20	2412-98	4	Clamp-Hose	35	105-8342	1	Hose-Fuel
21	1-603770	1	Valve-Fuel	37	116-4464	1	Plug-Port

# Hydro Assembly

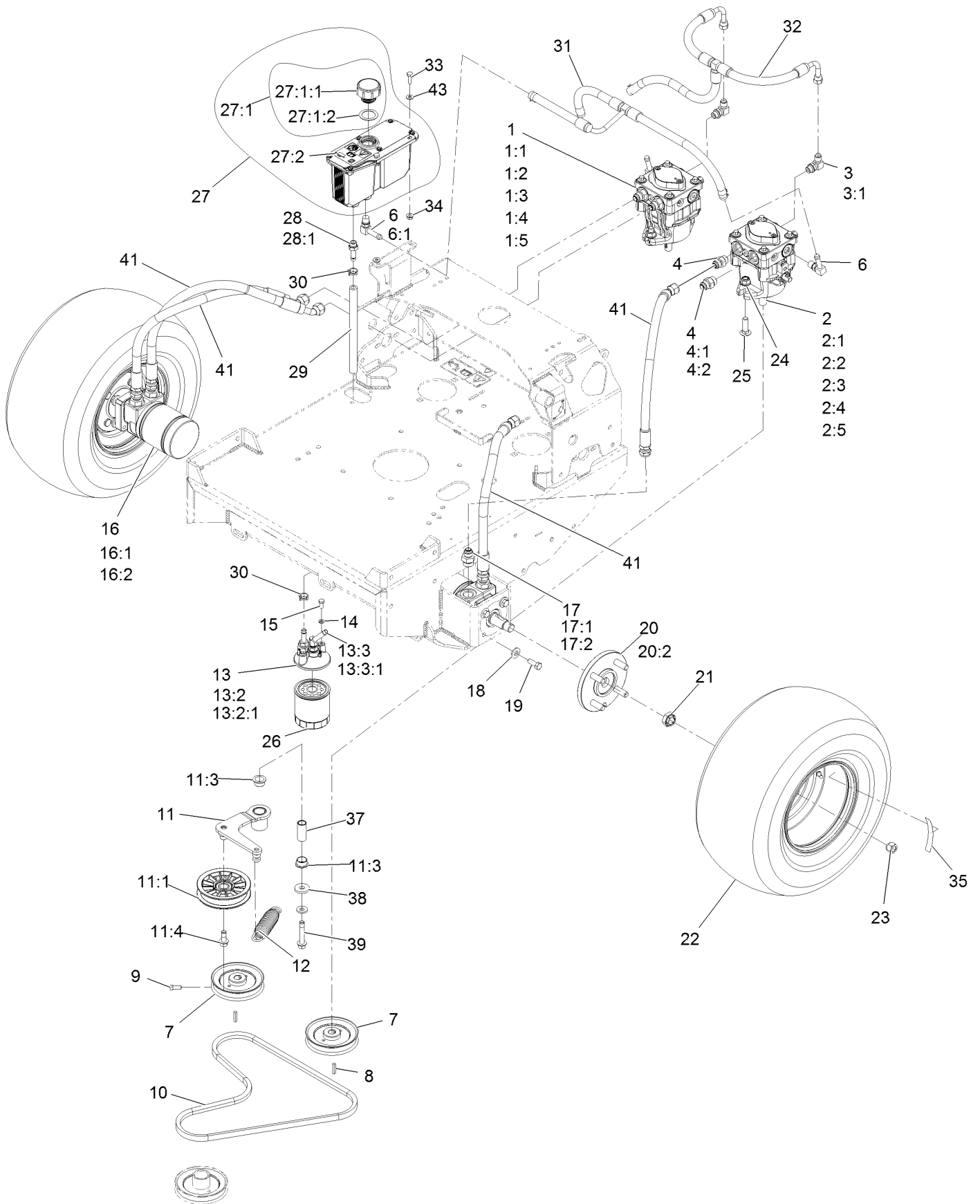

## Hydro Assembly (continued)

<i>Ref.</i>	<i>Part Number</i>	<i>Qty.</i>	<i>Description</i>	<i>Ref.</i>	<i>Part Number</i>	<i>Qty.</i>	<i>Description</i>
1	116-2495	1	Pump-HYD Pe RH TTH	16:1	1-000119	1	Seal Kit
1:1	103-2664	1	Input Shaft Kit	16:2	1-000138	1	Bearing And Seal Kit
1:2	94-6922	1	Bearing-Thrust	17	1-603991	4	Fitting-Straight
1:3	103-2666	1	Cylinder Block Kit	17:1	237-80	1	O-Ring
1:4	105-6184	1	Seal Overhaul Kit	17:2	1-603992	1	O-Ring
1:5	126-2479	1	Kit, 10Cc/12Cc Pump Kit	18	98-5975	9	Washer-Belleville
2	116-2494	1	Pump-HYD Pe LH TTH	19	323-6	8	Screw-HH
2:1	103-2664	1	Input Shaft Kit	20	112-9049	2	Wheel Hub ASM
2:2	94-6922	1	Bearing-Thrust	20:2	1-633926	4	Stud-Wheel
2:3	103-2666	1	Cylinder Block Kit	21	116-2839	2	Nut-Lock
2:4	105-6184	1	Seal Overhaul Kit	22	103-1715	2	Tire And Wheel Assy
2:5	126-2479	1	Kit, 10Cc/12Cc Pump Kit	23	242-50	8	Nut-Lug
3	103-1802	2	Fitting-Elbow, 90 DEG	24	114-8417	4	Nut-HF, NI
3:1	237-42	1	O-Ring	25	3232-3	4	Bolt-CARR
4	1-603990	4	Fitting-Straight	26	109-4180	1	Element, Oil Filter
4:1	1-603920	1	O-Ring	27	126-1248	1	ASM, HYD Reservoir ■
4:2	1-603992	1	O-Ring	27:1		1	Reservoir-HYD ●
6	100-4887	3	Fitting-Elbow, 90	27:1:1	103-1948	1	Cap-Reservoir, HYD
6:1	237-42	1	O-Ring	27:1:2	103-1949	1	Gasket-Cap
7	1-413010	2	Sheave ASM	27:2	115-4212	1	Decal-Warning
8	1-807272	2	Key	28	103-1912	1	Adapter-Straight
9	120-6474	4	Screw-Set, SQH	28:1	237-42	1	O-Ring
10	103-4761	1	Belt	29	103-2959	1	Hose-Charge
11	126-2531	1	ASM, Pump Idler	30	103-1988	6	Clamp-Hose
11:1	109-4077	1	Pulley-Idler, Flat	31	126-2550	1	Hose, Case
11:3	109-8054	2	Bushing-Flange	32	126-2555	1	Hose, Charge
11:4	126-1680	1	Screw-Hfh	33	321-5	2	Screw-HH
12	116-6316	1	Spring-Extension	34	32128-32	2	Nut-HHF
13	126-0621	1	ASM, Filter Head	35	126-2056	2	Decal-Torque Wheel Lug-Hub
13:2	103-1912	1	Adapter-Straight	37	126-2954	1	Pivot, Idler
13:2:1	237-42	1	O-Ring	38	1-373034	1	Washer
13:3	103-1807	1	Fitting-Barbed, 45 DEG	39	126-2956	1	Screw-HHF
13:3:1	237-42	1	O-Ring	41	116-8646	4	Hose,Hydraulic W/Cover
14	1-805004	2	Washer-Lock	43	3256-22	2	Washer-Flat
15	321-3	2	Screw-HH				
16	1-603718	2	HYD Motor ASM				

● Not serviced separately

■ Use Exmark Premium Hydro Oil P/N 109-9828 (32oz)

# Electrical Assembly

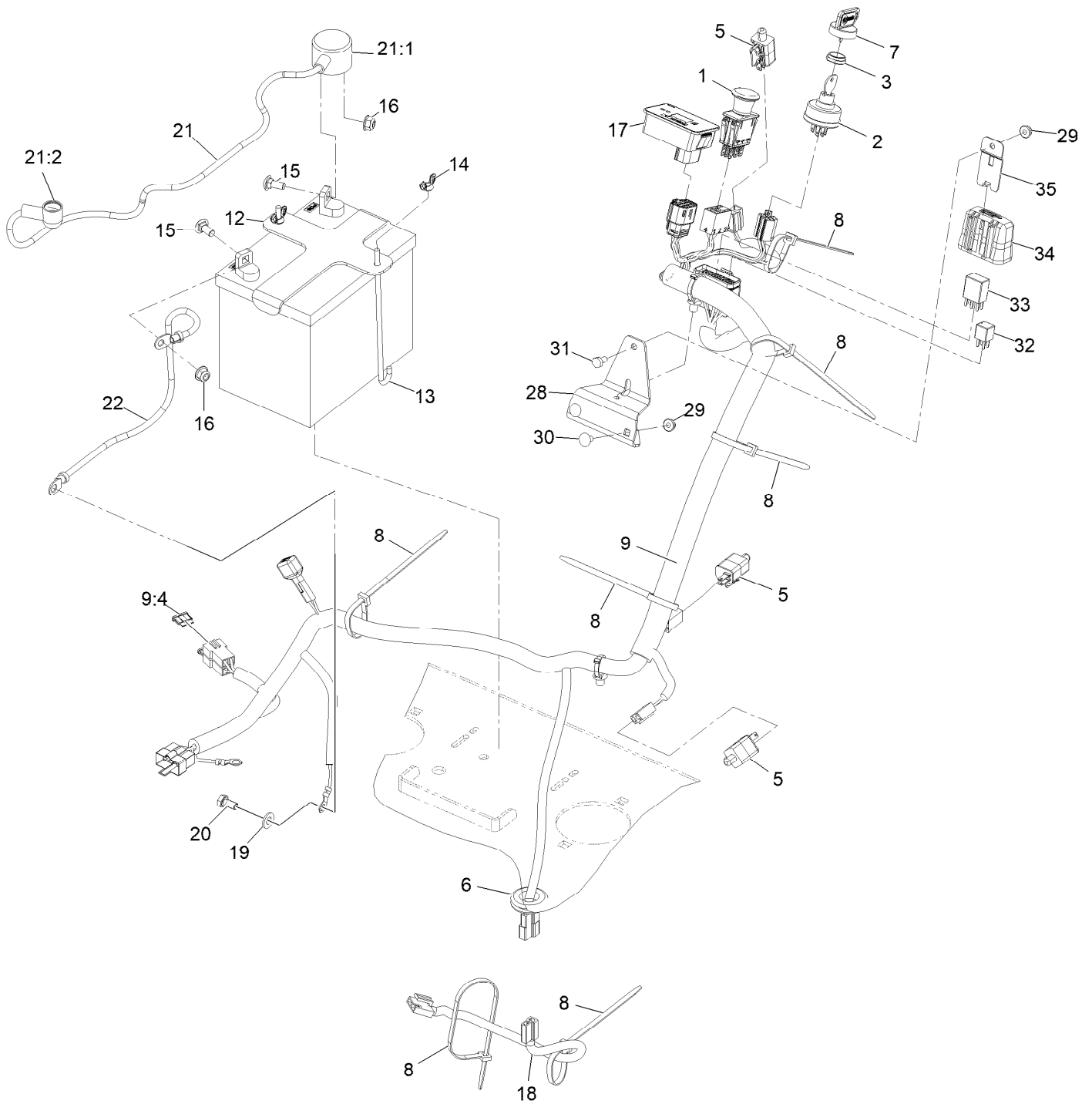

## Electrical Assembly (continued)

<i>Ref.</i>	<i>Part Number</i>	<i>Qty.</i>	<i>Description</i>	<i>Ref.</i>	<i>Part Number</i>	<i>Qty.</i>	<i>Description</i>
1	103-5221	1	Switch-PTO	18	126-0624	1	Harness-Clutch Pigtail
2	135-2253	1	Switch, Key Start	19	33094-00	1	Washer
3	103-0498	1	Nut-Ignition	20	33114-016	1	Screw-HH M8-1.25 X 16Mm
5	110-6765	3	Switch	21	109-7621	1	Positive Battery Cable ASM
6	1-543286	1	Grommet	21:1	1-543393	1	Insulator-Solenoid
7	103-2106	1	Key-Exmark Logo	21:2	109-2407	1	Insulator-Battery
8	3290-378	7	Tie-Cable	22	1-413540	1	Cable-Battery, Negative ●
9	135-1870	1	Harness-Wiring ■	28	135-2564-03	1	Bracket, Mounting Pdm
9:4	1-816001	2	Fuse-Blade Type, 20 Amp	29	104-7201	3	Nut-Nyloc 1/4-20 Flg
12	135-2056	1	Bracket, Battery Hold Down	30	3229-10	2	Bolt-Carriage 1/4-20 X 1/2
13	1-633651	2	Bolt-Holddown	31	321-2	1	Screw-HH 1/4-20 X 1/2
14	1-543792	2	Wingnut-Nyloc 1/4-20	32	126-3991	1	Relay-Micro
15	3230-1	2	Bolt-Carriage 5/16-18 X 3/4	33	126-6157	1	Relay-Micro 280, Spdt
16	104-8300	2	Nut-Nyloc 5/16-18 Flg	34	32180-176	1	Cover-Block, Fuse
17	142-2440	1	Module-Hour Meter	35	32180-177	1	Clip-Mounting

● Not illustrated

■ Use dielectric grease on all unsealed connectors and terminals only. Do not apply in sealed connectors.

**Notes:**



# MAXIMIZE THE PERFORMANCE OF YOUR EXMARK MACHINE.



## EXMARK® PREMIUM ENGINE OIL

Exmark now offers a family of engine oil viscosities to perform well in any environment. Each viscosity has the same synthetic formulation to give you what you need in punishing conditions. We designed each grade to the highest quality, making it ideal even for diesel applications. Coupled with Exmark Premium Fuel Treatment, we have the performance products to make your machine hum.

### EXMARK PREMIUM ENGINE OIL SAE 30/10W-30

- Meets zero shear requirements of a straight grade SAE 30 as well as the cold temp properties of a 10W-30.
- Most versatile oil in the industry.
- Superior corrosion protection over conventional oil - even in corrosive, humid environments.

### EXMARK PREMIUM ENGINE OIL SAE 20W-50

- Perfect for your big block engine, or any application in severe service.
- Same full synthetic formulation as all other Exmark Premium viscosities.
- Also effective for use in severe service small block engines.

### EXMARK PREMIUM ENGINE OIL SAE 10W-50

- Full synthetic formulation gives you peak performance. Don't settle for less.
- Wide span multi-grade combines easy starting in cold weather with maximum protection in high temperature operation.
- Reduce friction & wear over standard mineral formulations.

### EXMARK PREMIUM ENGINE OIL SAE 0W-40

- The perfect choice for when the weather turns cold or unpredictable, and your Exmark UTV has to perform.
- Commercial quality for severe service.
- Advanced additive package helps prevent corrosion from long-term storage.

### EXMARK PREMIUM ENGINE OIL UTV FORMULATION

- 4-cycle high-temp formulation.
- Heavier viscosity, full synthetic, perfect for your UTV.

### EXMARK PREMIUM UTV EXTREME CONDITIONS GEAR OIL

- SAE 80W-90, designed to keep your UTV performing at its peak.
- Shear stable, hypoid gear lube.
- Includes a premium additive system to combat wear, oxidation, rust & corrosion.

**Available from your local Exmark dealer. Find your closest dealer at [exmark.com](http://exmark.com)**

## EXMARK ACCESSORIES AND OPTIONS\*

### MID-MOUNT RIDING ACCESSORIES AND OPTIONS

CUSTOM RIDE SEAT SUSPENSION SYSTEM	OPERATOR CONTROLLED DISCHARGE
FULL SUSPENSION SEAT	SUN SHADE
DECK LIFT ASSIST KIT	TRASH CONTAINER
HITCH KIT	TURF STRIPER
LIGHT KIT	ULTRA VAC COLLECTION SYSTEM
12V POWER PORT	ULTRA VAC QUICK DISPOSAL SYSTEM
MICRO-MULCH SYSTEM	

### OUT-FRONT RIDING ACCESSORIES AND OPTIONS

CUSTOM RIDE SEAT SUSPENSION SYSTEM	SNOW BLADE
DUAL-TAIL WHEEL	SNOWBLOWER
FLOOR PAN EXTENDER	SUN SHADE
HITCH KIT	TRASH CONTAINER
LIGHT KIT	ULTRA VAC COLLECTION SYSTEM
MICRO-MULCH SYSTEM	ULTRA VAC QUICK DISPOSAL SYSTEM
ROLL OVER PROTECTION SYSTEM (ROPS)	WEATHER CAB

### WALK-BEHIND ACCESSORIES AND OPTIONS

GRASS CATCHER	TURF STRIPER
MICRO-MULCH SYSTEM	STANDON

\*Some accessories and options not available for some models.

Place Model No. and Serial No.  
Label Here (Included in the Literature  
Pack) or Fill in Below

Model No. \_\_\_\_\_

Serial No. \_\_\_\_\_

Date Purchased \_\_\_\_\_

Engine Model No. and Spec. No. \_\_\_\_\_

Engine Serial No. (E/No) \_\_\_\_\_

© 2020 Exmark Mfg. Co., Inc.  
415 Industrial Row  
Beatrice, NE 68310  
All Rights Reserved

Part No. 4505-412 Rev. A  
(402) 223-6375  
Fax (402) 223-5489  
Printed in the USA.

