

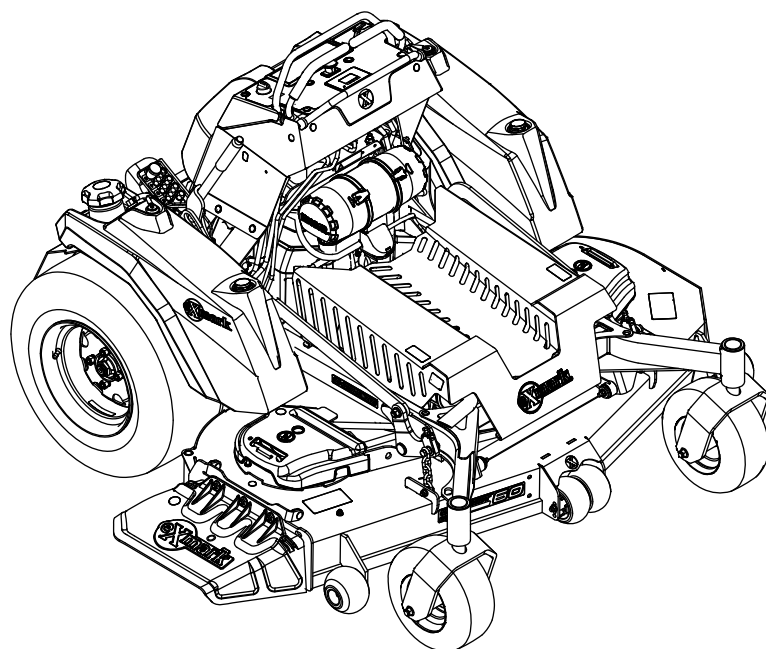

STARIS S-SERIES

Model No. STS730AKC52400—Serial No. 408644346 and Up

Picture below may not reflect actual product.



Parts Manual

Part No. 4505-323 Rev. A

Ordering Replacement Parts

To order replacement parts, please supply the part number, the quantity, and the description of each part desired.

Understanding Reference Numbers

Each identified part in an illustration has a reference number. The reference number for a part also appears in the parts list, along with other information about the part.

This catalog uses two special reference number formats, one to indicate parts in a service assembly and another to indicate the quantity of a given part in an illustration.

Service Assembly Reference Numbers

Parts in service assemblies have reference numbers in the form a:b. The a represents the reference number of the entire service assembly and the b represents a sequential number unique to each part within the service assembly.

For example, a wheel assembly might be identified by reference number 6, the tire by 6:1, the valve by 6:2, and the wheel by 6:3. When you order the assembly identified by reference number 6, you receive all parts identified by reference numbers 6:1, 6:2, and 6:3. However, you may also order any part individually. Reference numbers of this type appear in illustration and in parts lists.

Reference Numbers Indicating Quantity

In an illustration, if a reference number indicates more than one part, the reference number has the form nX y. The n represents the quantity of the part, the X is the multiplication symbol, and the y represents the reference number.

For example, in an illustration, the reference number 2X 37 means that two of the parts identified by reference number 37 are indicated.

Touch Up Paint

Exmark black touch up spray paint – gloss black.

Exmark red touch up paint (spray paint – P/N 1-850337 - .6 oz liquid bottle – P/N 103-9140).



If your Exmark dealer does not have the Exmark part in stock, Exmark will get the parts to the dealer the next business day or the part will be FREE Guaranteed!! (Some restrictions apply. See your participating Exmark Dealer for details.)

Contents

Complete Deck Assembly	4
Deck Assembly	6
Deck W/Decals Assembly	8
Deck Idler Assembly	10
Main Frame Assembly	12
Controls Assembly	14
Deck Lift Assembly	16
Deck Strut Assembly	18
Height of Cut Lever Assembly	20
Platform Assembly	22
Guarding Assembly	24
Park Brake Assembly	26
Drive Wheel Assembly	28
Caster Wheel Assembly	30
Engine Assembly	32
Fuel Assembly	34
Left Fuel Tank Assembly	36
Left Fuel Line Assembly	38
Right Fuel Tank Assembly	40
Right Fuel Line Assembly	42
Fuel Line Assembly	44
Hydraulic Assembly	46
Idler Arm Assembly	48
Electrical Assembly	50
Harness Assembly	52

Complete Deck Assembly

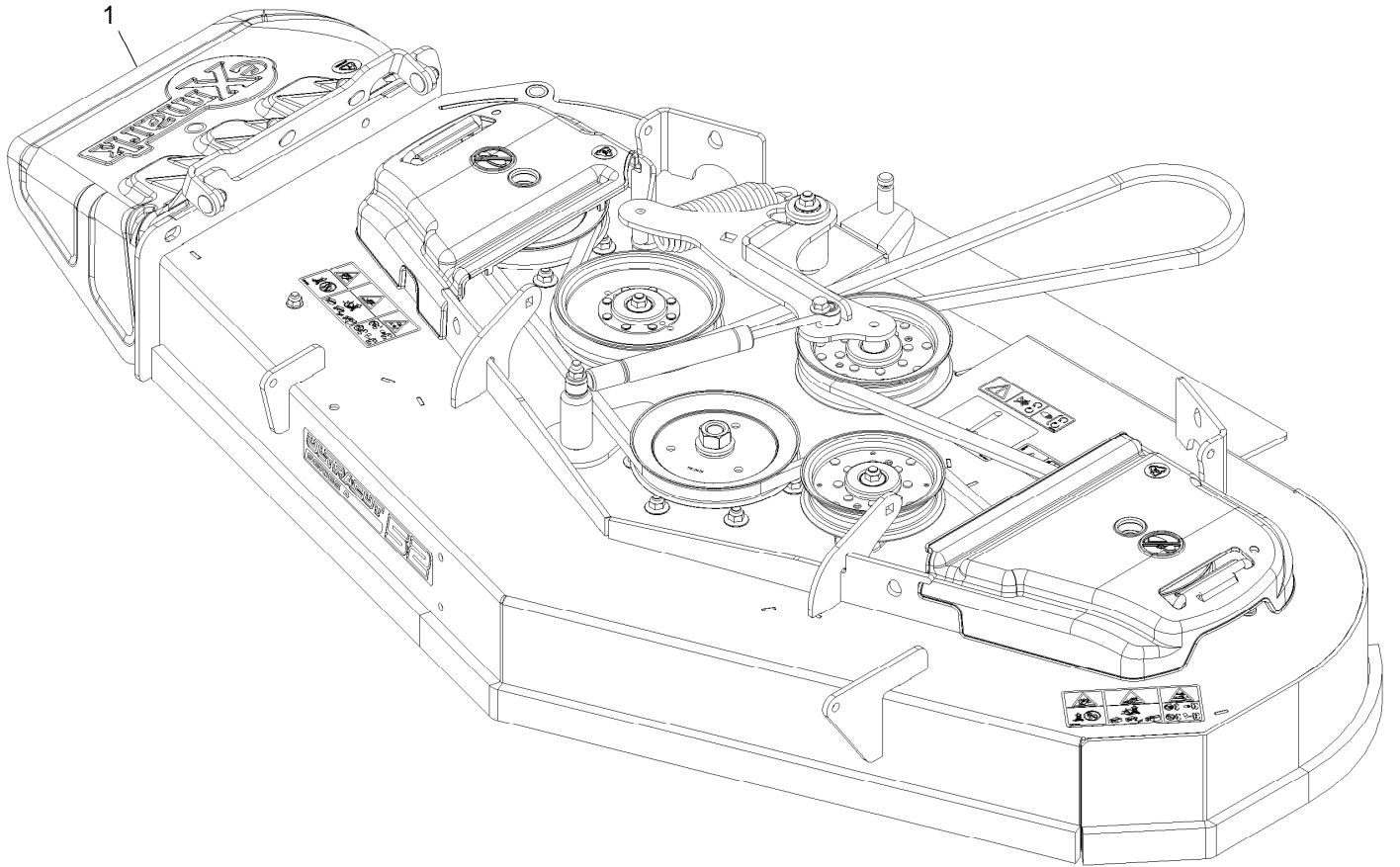

Complete Deck Assembly (continued)

<i>Ref.</i>	<i>Part Number</i>	<i>Qty.</i>	<i>Description</i>
1	135-6669	1	ASM, Complete Deck, 524

Deck Assembly

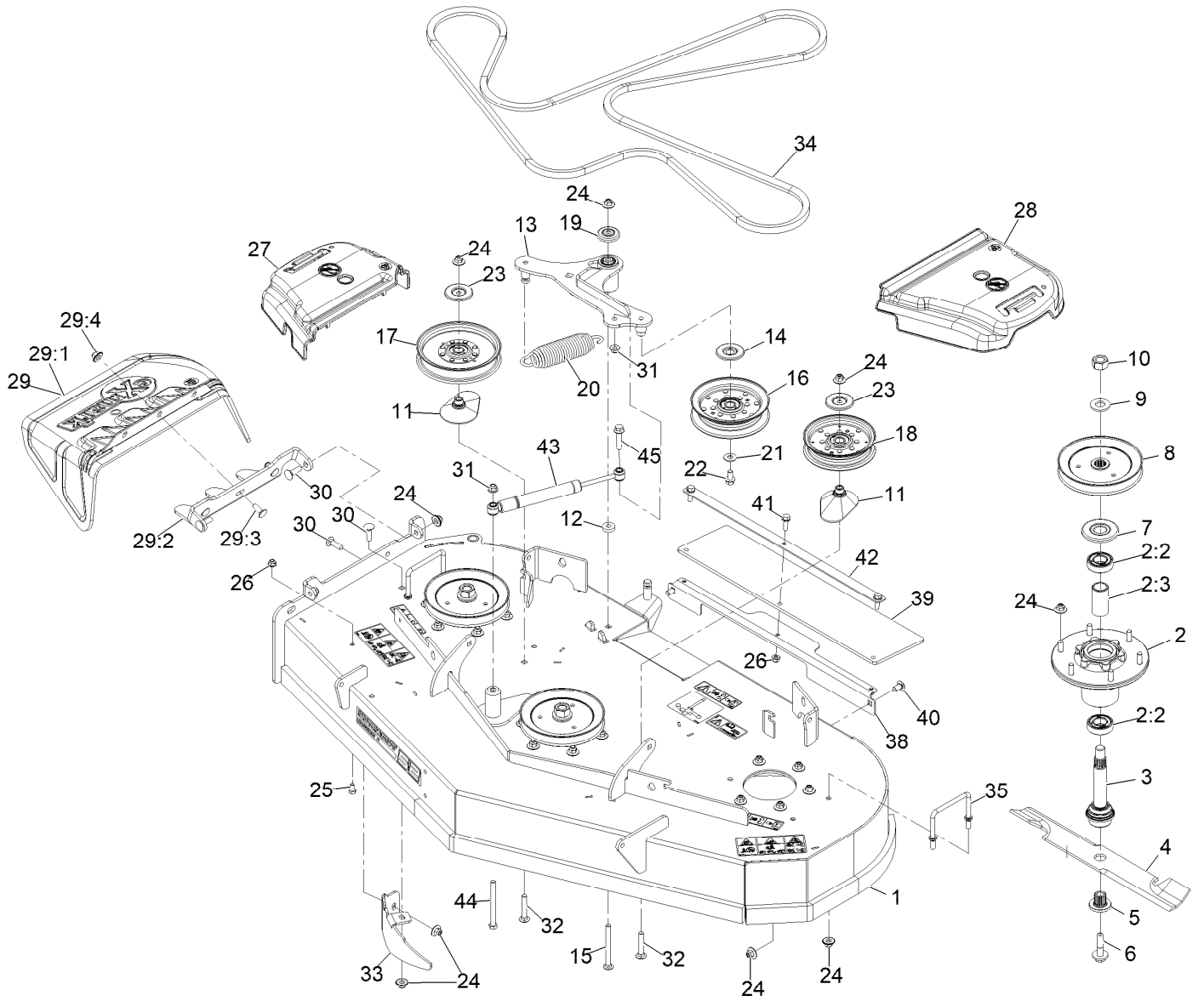

Deck Assembly (continued)

<i>Ref.</i>	<i>Part Number</i>	<i>Qty.</i>	<i>Description</i>	<i>Ref.</i>	<i>Part Number</i>	<i>Qty.</i>	<i>Description</i>
1	135-1908	1	ASM, Deck W/ Decals, 52"	22	110-1718	1	Screw-Hex Flange 3/8-16 X 3/4
2	116-3344	3	ASM-Cutter Hsg With Bearings	23	126-8043	2	Shield-Dust
2:2	116-0720	2	Bearing-Ball	24	109-6658	31	Nut-Nyloc 3/8-16 Flg
2:3	116-3312	1	Spacer-Bearing	25	322-2	1	Screw-HH 5/16-18 X 5/8
3	116-3341	3	ASM-Spindle And Seal	26	104-8300	4	Nut-Nyloc 5/16-18 Flg
4	116-5175	3	Blade-Extreme 2, 18.00" ●	27	109-6935	1	Cover-Belt, RH
4	103-6402	3	Blade-Notched	28	109-6936	1	Cover-Belt, LH
4	103-6392	3	Blade, Mulching ■	29	109-7188	1	ASM,Discharge Chute
4	103-6387	3	Blade, Low Lift ●	29:1	109-2738	1	Chute, Discharge
4	103-6382	3	Blade, Solid ●	29:2	109-8675-01	1	Bracket,Discharge Chute
5	103-3037	3	Bushing, Splined	29:3	3231-22	3	Bolt-Carriage 3/8-16 X 1
6	109-9220	3	Screw-Sems 1/2-20 X 2.19	29:4	109-6658	3	Nut-Nyloc 3/8-16 Flg
7	116-1286	3	Guard,Bearing Top .989	30	3231-25	4	Bolt-Carriage 3/8-16 X 1 1/4
8	116-0675	3	Sheave,Blade Drive 6.50	31	104-8301	2	Nut-HF, NI
9	103-2802	3	Washer-Spring Disc 3/4	32	3231-7	2	Bolt-Carriage 3/8-16 X 2 1/4
10	116-7306	3	Nut-Hex	33	116-5814-01	1	Baffle-Dogleg, Lz-Vt52
11	109-2872	2	Spacer-Pulley	34	135-5078	1	Belt, 5V
12	62-6660	1	Spacer	35	109-6982	2	Wireform-Cover
13	135-7394	1	ASM-Deck Idler	38	135-6287-03	1	Brkt, Heat Deflector
14	126-9195	1	Shield-Guard, Dust	39	135-6358	1	Shield, Heat
15	3231-37	1	Bolt-Carriage 3/8-16 X 4	40	3231-21	2	Bolt-Carriage 3/8-16 X 3/4
16	126-9196	1	Idler-Pulley, Flat	41	3234-29	3	Screw-HH Flg 5/16-18 X 1
17	126-9189	1	Idler-Pulley, Flat 6.00X1.00	42	135-7122-03	1	Brkt-Heat Deflector, Top
18	126-9187	1	Pulley-Idler, Flat	43	135-7252	1	Damper
19	103-2916	1	Guard-Top	44	323-17	1	Screw-HH 3/8-16 X 4 1/4
20	116-6317	1	Spring-Extension	45	3234-19	1	Screw-HHF 3/8-16 X 1 3/4
21	3256-4	1	Washer-3/8 Std				

● Optional Equipment

■ Requires installation of mulch kit for proper mulching. See your Exmark dealer for details.

Deck W/Decals Assembly

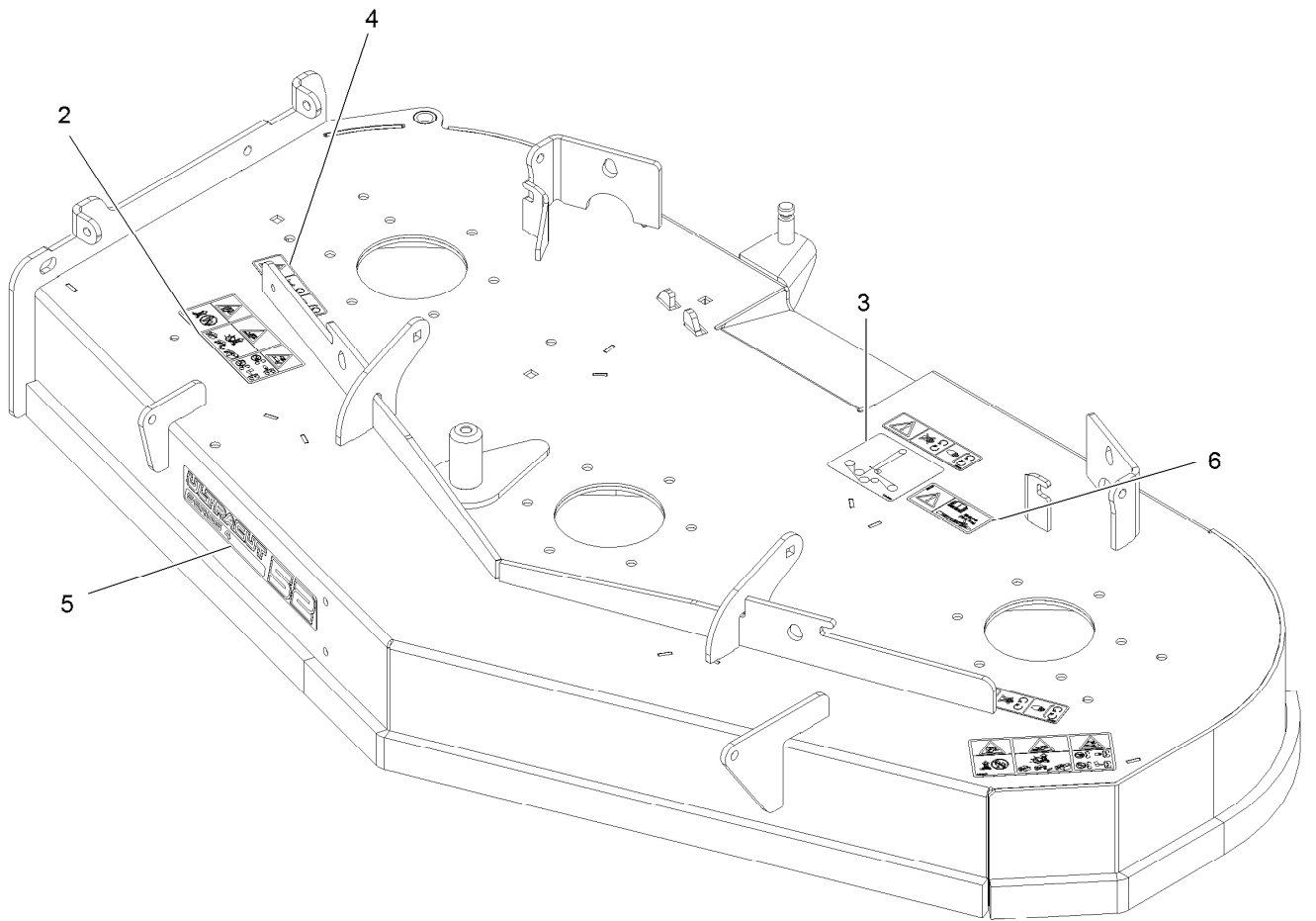

Deck W/Decals Assembly (continued)

<i>Ref.</i>	<i>Part Number</i>	<i>Qty.</i>	<i>Description</i>	<i>Ref.</i>	<i>Part Number</i>	<i>Qty.</i>	<i>Description</i>
2	135-5210	2	Decal-Warning Thrown Obj	5	126-6588	1	Decal, 524
3	116-8727	1	Decal-Belt Routing	6	116-8283	1	Decal-Torque, Bolt
4	112-9028	3	Decal-Cover, Missing				

Deck Idler Assembly

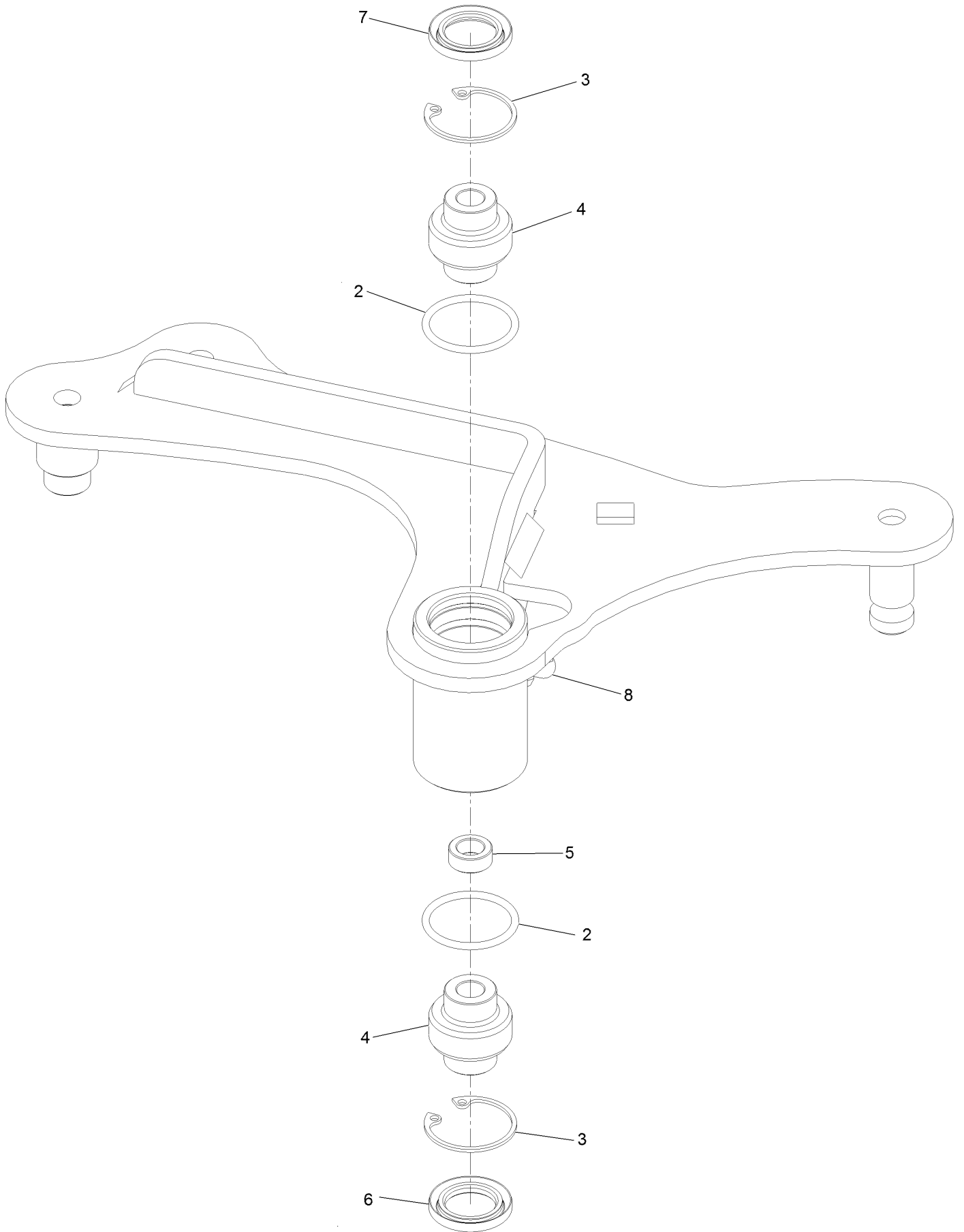

Deck Idler Assembly (continued)

<i>Ref.</i>	<i>Part Number</i>	<i>Qty.</i>	<i>Description</i>	<i>Ref.</i>	<i>Part Number</i>	<i>Qty.</i>	<i>Description</i>
2	106-7159	2	O-Ring	6	103-3505	1	Seal-Lip, Double
3	32120-10	2	Ring-Retaining	7	103-3506	1	Seal-Single Lip
4	103-3504	2	Bearing-Spherical	8	302-40	1	Zerk-90° 1/4-28
5	103-5677	1	Spacer				

Main Frame Assembly

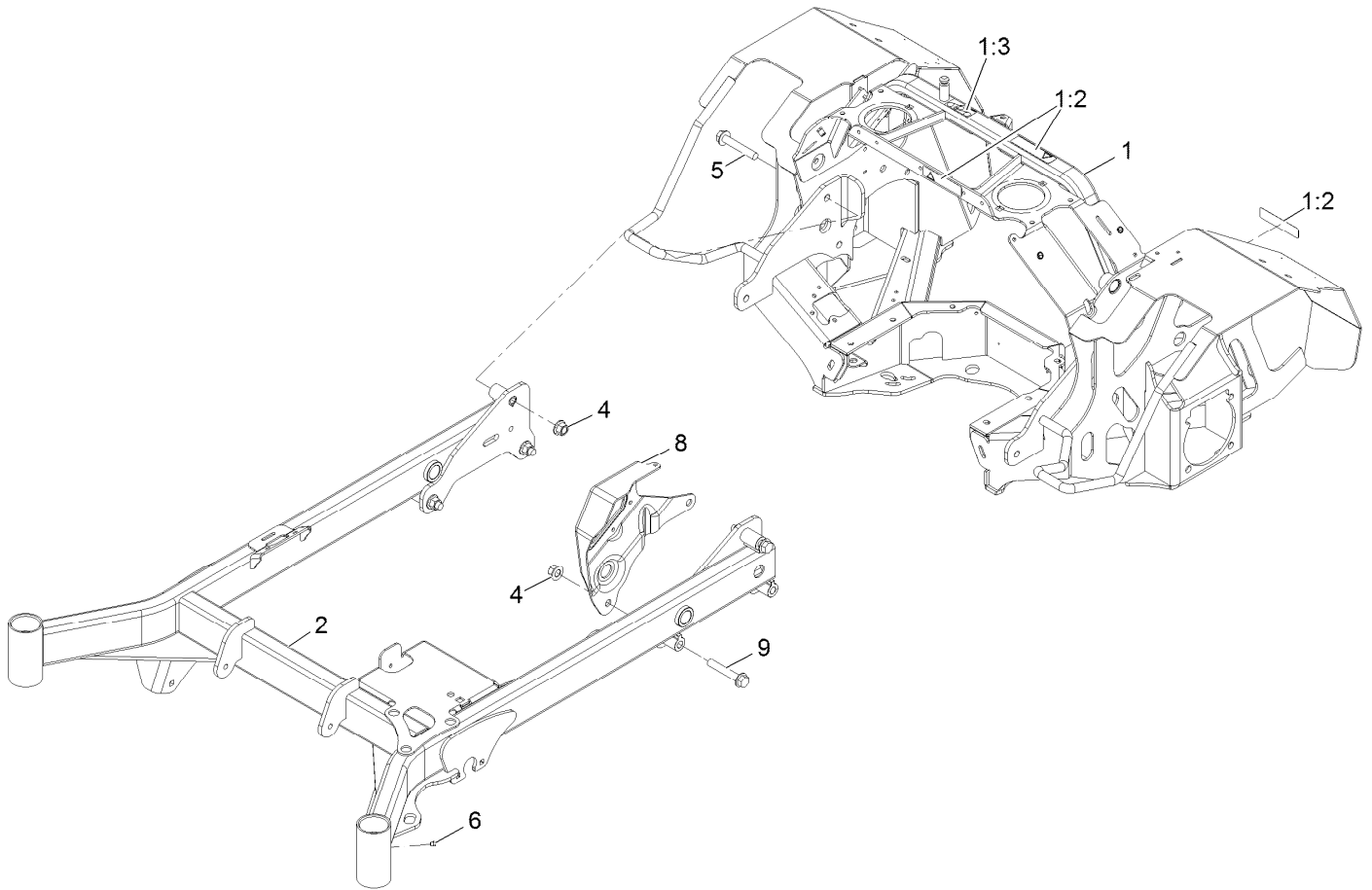

Main Frame Assembly (continued)

<i>Ref.</i>	<i>Part Number</i>	<i>Qty.</i>	<i>Description</i>	<i>Ref.</i>	<i>Part Number</i>	<i>Qty.</i>	<i>Description</i>
1	142-2409	1	ASM, Rear Frame W/ Decals	4	99-5107	6	Nut-Lock 1/2-13
1:2	98-1977	3	Decal-Warning	5	3234-40	4	Screw-HF
1:3	135-2267	1	Decal-Belt Routing HYD	6	1-811010	2	Plug
2	135-1176-01	1	Weld, Front Frame, 48/52	8	135-6756-03	1	Weld, Fuel Module
				9	135-7112	2	Screw-HHF

Controls Assembly

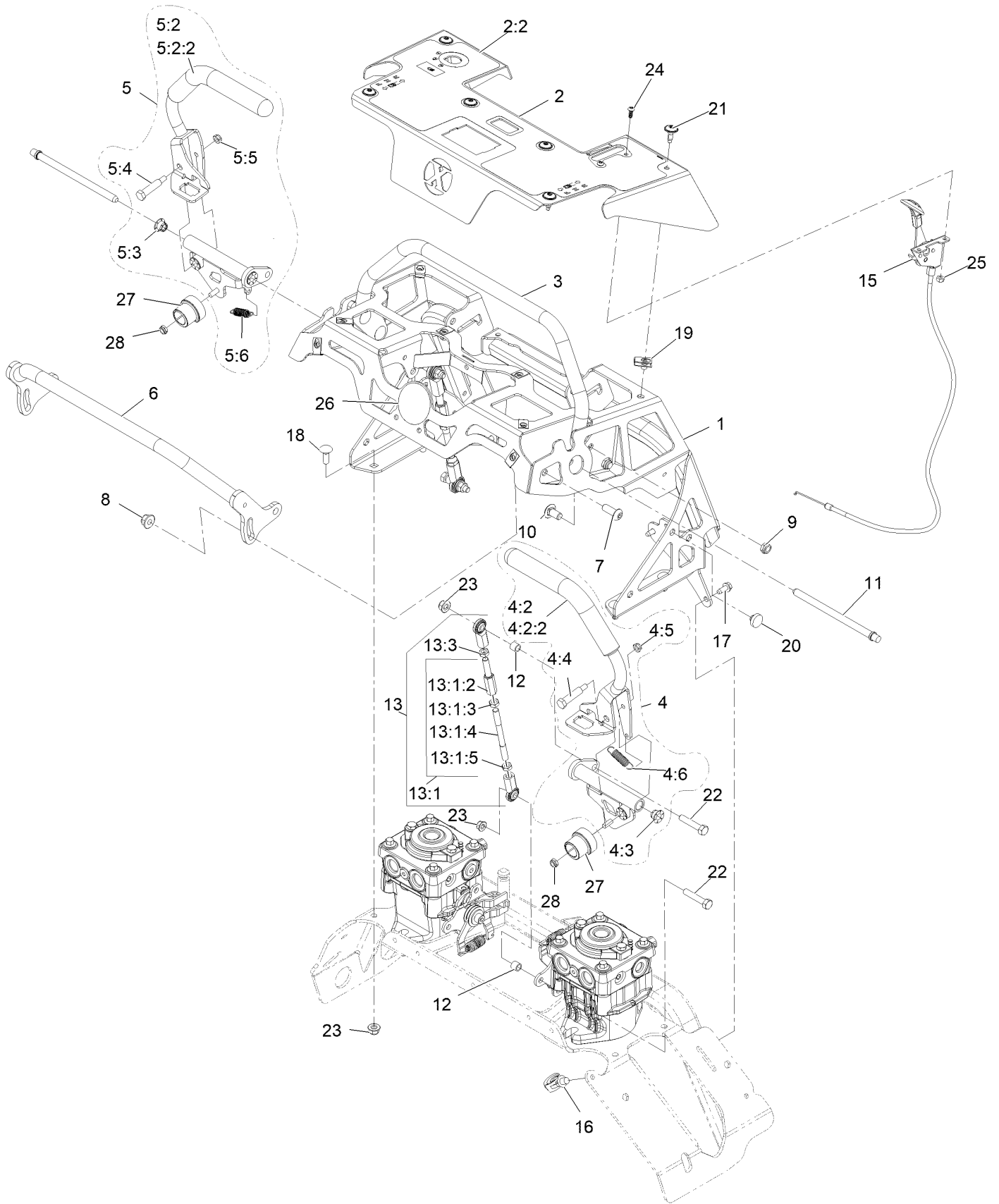

Controls Assembly (continued)

<i>Ref.</i>	<i>Part Number</i>	<i>Qty.</i>	<i>Description</i>	<i>Ref.</i>	<i>Part Number</i>	<i>Qty.</i>	<i>Description</i>
1	135-4142	1	ASM, Control Tower W/ Decal	9	3296-59	4	Nut-Nyloc 3/8-16 Thin
2	142-2418	1	ASM, Control Panel W/ Decal	10	3231-21	4	Bolt-Carriage 3/8-16 X 3/4
2:2	135-6772	1	Decal-Control Panel EFI	11	135-1277	2	Pin, Pivot
3	135-3430-05	1	Weld, Rear Ref Bar	12	1-633545	4	Spacer
4	135-1304	1	ASM, Motion Control, Lt	13	135-7116	2	ASM, Linkage
4:2	135-2546	1	ASM, Lt Control Lever W/ Grip	13:1		1	ASM, Motion Control Link ●
4:2:2	135-3301	1	Grip, Drive Lever	13:1:2	116-4755	1	Rod-Adjustment
4:3	135-6412	4	Bearing, Igus	13:1:3	3220-16	1	Nut-Jam 3/8-24 LH
4:4	121-1229	1	Bolt-Shoulder	13:1:4	135-1291	1	Link, Motion Control
4:5	3296-56	1	Nut-Nyloc 1/4-20 Thin	13:1:5	3220-3	1	Nut-Jam 3/8-24
4:6	114-0249	1	Spring-Extension	13:3	3220-3	1	Nut-Jam 3/8-24
5	135-1305	1	ASM, Motion Control, Rt	15	135-4352	1	Cable, Throttle
5:2	135-2547	1	ASM, Rt Control Lever W/ Grip	16	32180-030	1	Clip-Tie
5:2:2	135-3301	1	Grip, Drive Lever	17	32144-10	4	Screw-HWH 1/4-20 X .62
5:3	135-6412	4	Bearing, Igus	18	3230-16	4	Bolt-Carriage 5/16-18 X 7/8
5:4	121-1229	1	Bolt-Shoulder	19	107069	8	Nut-Retainer-Panel 1/4-20
5:5	3296-56	1	Nut-Nyloc 1/4-20 Thin	20	1-513658	2	Bumper
5:6	114-0249	1	Spring-Extension	21	135-3494	6	Screw, Torx
6	135-3432-05	1	Weld, Front Ref Bar	22	322-8	4	Screw-HH
7	3274-94	2	Screw-Button Head 3/8-16 X 1	23	104-8300	8	Nut-Nyloc 5/16-18 Flg
8	104-8301	2	Nut-Nyloc 3/8-16 Flg	24	135-3176	2	Screw, BHCS
				25	3296-2	2	Nut-Nyloc #10-24
				26	135-2281	1	Decal-Cover
				27	126-1499	2	Cam
				28	3296-56	2	Nut-Nyloc 1/4-20 Thin

● Not serviced separately

Deck Lift Assembly

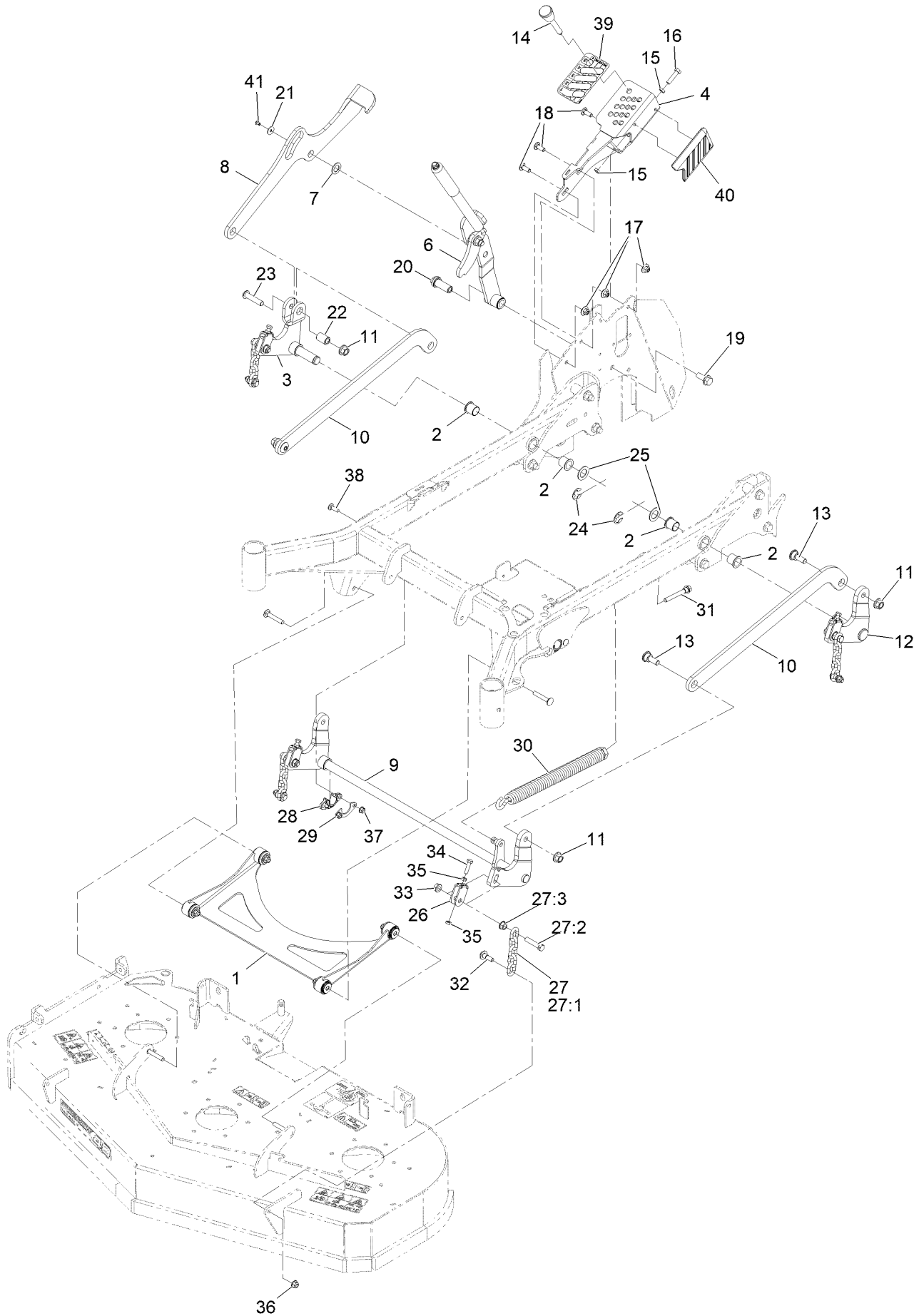

Deck Lift Assembly (continued)

<i>Ref.</i>	<i>Part Number</i>	<i>Qty.</i>	<i>Description</i>	<i>Ref.</i>	<i>Part Number</i>	<i>Qty.</i>	<i>Description</i>
1	142-4364	1	ASM, Deck Strut	24	32151-103	2	E-Ring
2	135-1248	4	Bushing, Igus	25	119-2332	2	Washer-Flat
3	135-4586-03	1	Weld, Bellcrank, Rt	26	109-9066	4	Yoke-Adjust, Deck
4	142-2300-03	1	Weld, HOC Index	27	116-0756	4	Deck Lift Chain ASM
6	142-6677	1	ASM- Lever HOC	27:1	1-633447	1	Chain-Lift, Deck
7	119-7640	1	Washer-Thrust	27:2	109-9065	1	Screw-HH 7/16-14 X 2
8	142-3040-03	1	Strap, HOC Index	27:3	32128-37	1	Nut-Whizlock 7/16-14
9	135-4585-03	1	Weld, HOC Cross Shaft	28	115-5065	2	Bushing-Flange
10	135-1253-03	2	Strap, HOC Lift	29	116-2887	2	Gusset-Lift, Deck
11	99-5107	4	Nut-Lock 1/2-13	30	116-0886	1	Spring-Extension
12	135-4587-03	1	Weld, Bellcrank	31	92-7674	1	Screw-Shcs 3/8-16 X 2.212
13	135-1259	3	Bolt, Shoulder	32	109-9840	4	Screw-Hex Flange 3/8-16 X .80
14	126-5401	1	Pin-HOC	33	32128-37	4	Nut-Whizlock 7/16-14
15	3218-3	2	Nut-Jam 3/8-16	34	322-47	4	Screw-HH 5/16-18 X 1 1/4
16	323-50	1	Bolt-HH	35	3218-2	8	Nut-Jam 5/16-18
17	109-6658	3	Nut-Nyloc 3/8-16 Flg	36	104-8301	4	Nut-Nyloc 3/8-16 Flg
18	3231-22	3	Bolt-Carriage 3/8-16 X 1	37	104-8300	4	Nut-Nyloc 5/16-18 Flg
19	3234-38	1	Screw-HHF 1/2-13 X 1 1/4	38	3230-2	4	Bolt-Carriage 5/16-18 X 1
20	142-2181	1	Pivot, HOC Lever	39	135-2280	1	Decal-Height Of Cut
21	3256-67	1	Washer	40	135-5337	1	Pad, Knee
22	135-3944	1	Spacer, HOC	41	142-2216	1	Screw, 1/4-20 X 3/8 PH Torx
23	135-3945	1	Screw-HSBH				

Deck Strut Assembly

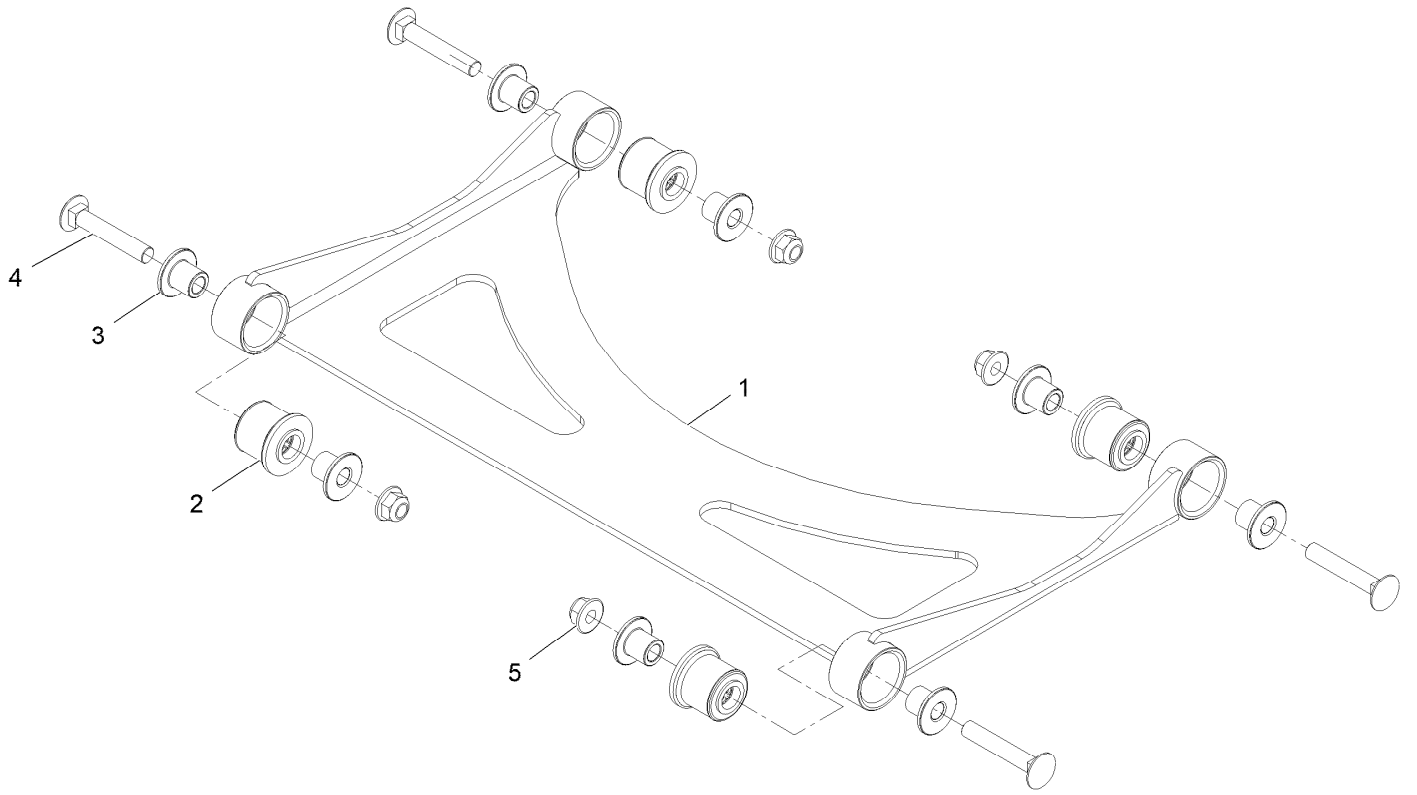

Deck Strut Assembly (continued)

<i>Ref.</i>	<i>Part Number</i>	<i>Qty.</i>	<i>Description</i>	<i>Ref.</i>	<i>Part Number</i>	<i>Qty.</i>	<i>Description</i>
1	142-4363-03	1	Weld, Deck Strut	4	3231-7	4	Bolt-Carriage 3/8-16 X 2 1/4
2	137-4108	4	Bushing-Rubber	5	104-8301	4	Nut-Nyloc 3/8-16 Flg
3	142-4319	8	Spacer, Strut				

Height of Cut Lever Assembly

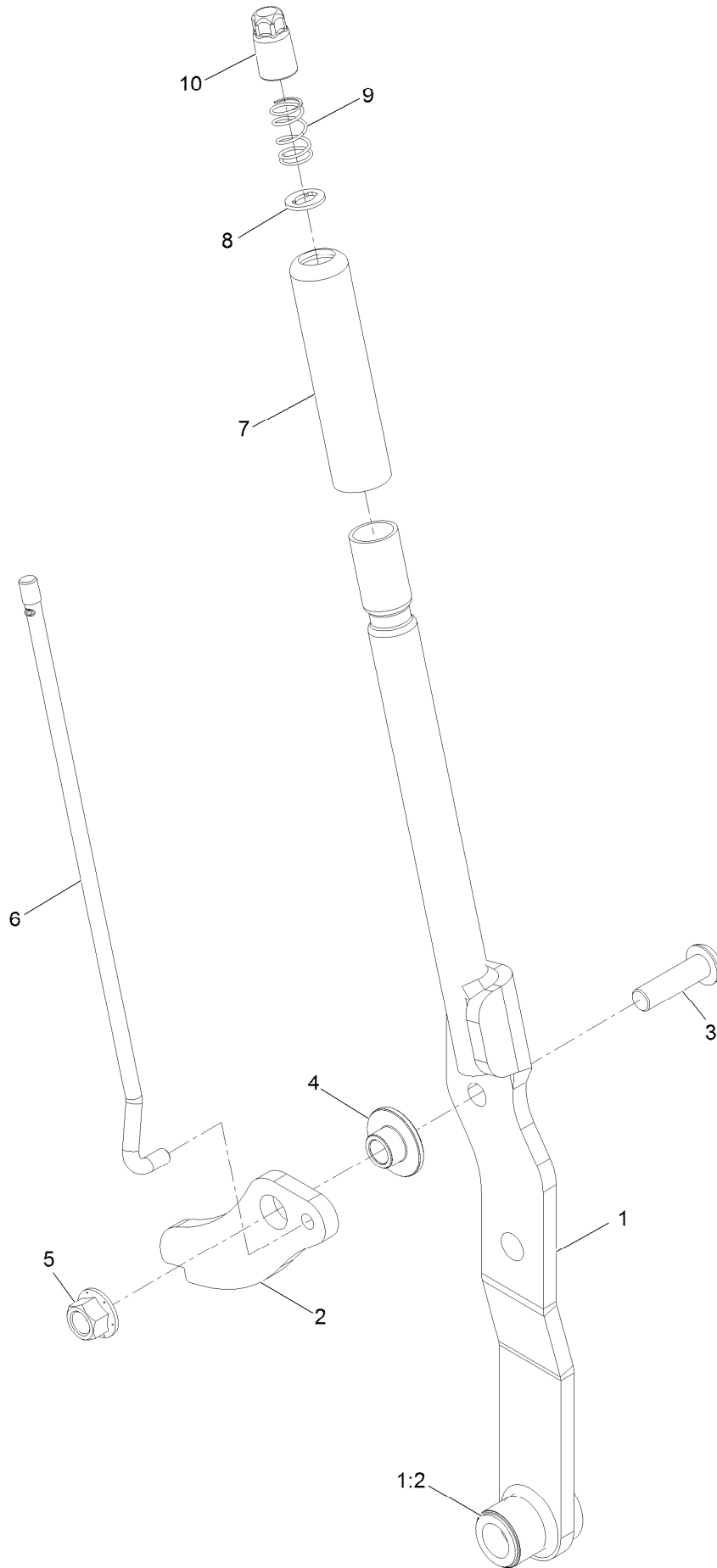

Height of Cut Lever Assembly (continued)

<i>Ref.</i>	<i>Part Number</i>	<i>Qty.</i>	<i>Description</i>	<i>Ref.</i>	<i>Part Number</i>	<i>Qty.</i>	<i>Description</i>
1		1	ASM, HOC Lever ●	5	99-5107	1	Nut-Lock 1/2-13
1	135-7939	1	ASM, HOC Lever W/ Bushings	6	135-1260	1	Linc, HOC
1:2	109-8054	2	Bushing-Flanged	7	115-3592	1	Grip
2	135-1209	1	Arm, Transport Lock	8	114-1207	1	Washer-Special
3	108-1993	1	Screw-HSBH	9	114-8187	1	Spring-Compression
4	135-3954	1	Spacer	10	135-7809	1	Button, Push

● Not serviced separately

Platform Assembly

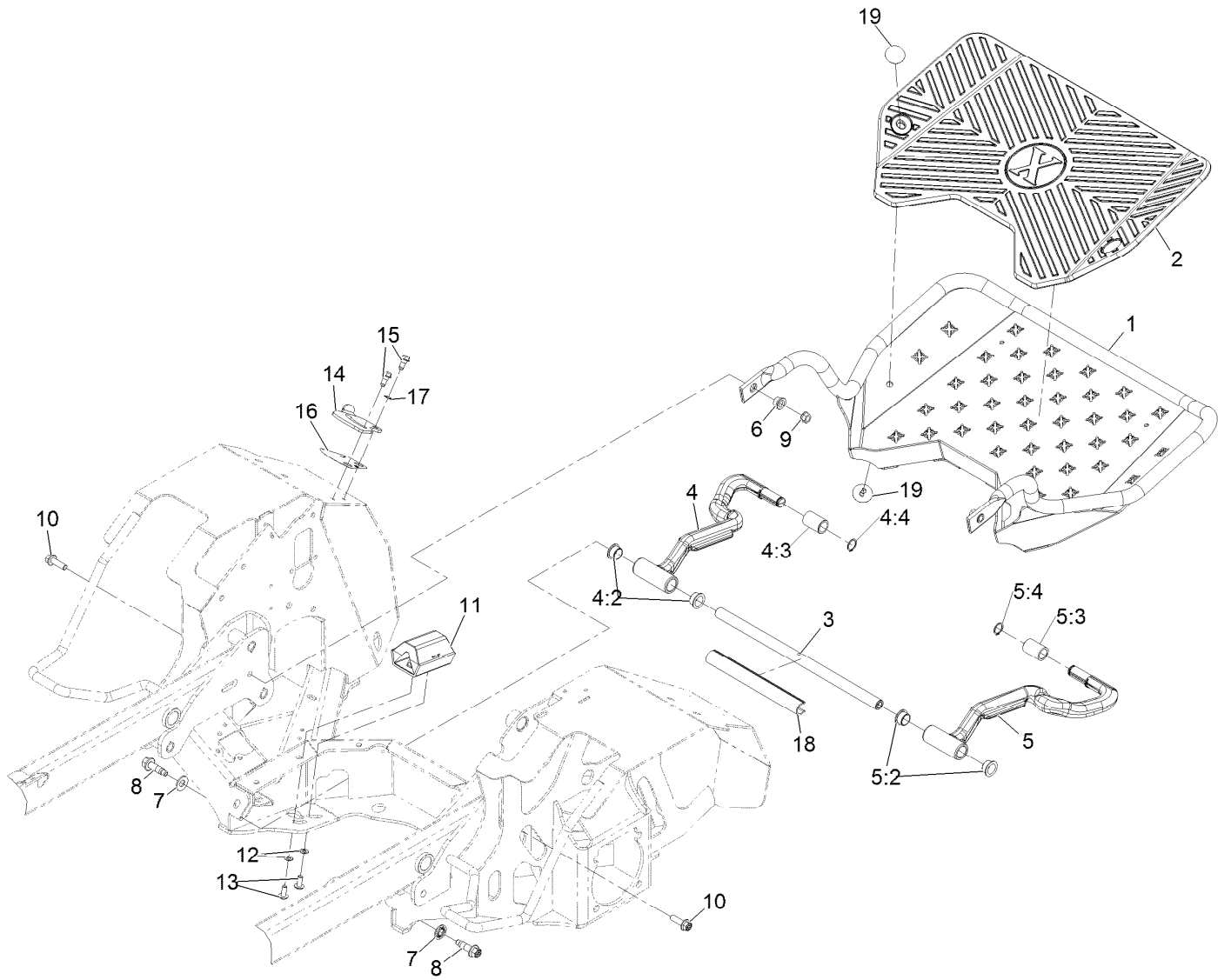

Platform Assembly (continued)

<i>Ref.</i>	<i>Part Number</i>	<i>Qty.</i>	<i>Description</i>	<i>Ref.</i>	<i>Part Number</i>	<i>Qty.</i>	<i>Description</i>
1	142-2748-05	1	Weld, Platform	9	32128-21	2	Nut-3/8-16 Flanged Side Lock
2	142-3129	1	Mat, Platform	10	135-4712	2	Screw, HHF
3	135-1336	1	Shaft, Cross	11	135-3993	2	Bumper
4	135-2237	1	ASM, Rt Arm W/ Bushings	12	3255-8	4	Washer-Lock 5/16 (Ext-Tooth)
4:2	109-8054	2	Bushing-Flanged	13	126-6268	4	Screw-Truss HD 5/16-18 X 3/4 Torx Plus
4:3	135-6438	1	Bushing, Sleeve	14	142-2492-03	1	Latch, Platform
4:4	32120-72	1	Ring-Snap	15	126-4424	2	Screw-Shoulder
5	135-2236	1	ASM, Lt Arm W/ Bushings	16	135-5206	1	Decal-Latch Lock
5:2	109-8054	2	Bushing-Flanged	17	142-2432	1	Washer, Wave
5:3	135-6438	1	Bushing, Sleeve	18	135-7563	1	Keeper
5:4	32120-72	1	Ring-Snap	19	142-3247	4	Rivet-Ratchet
6	109-8788	2	Bushing-Flanged				
7	1-603610	2	Washer-Spring Disc 7/16				
8	135-7001	2	Screw-HHF				

Guarding Assembly

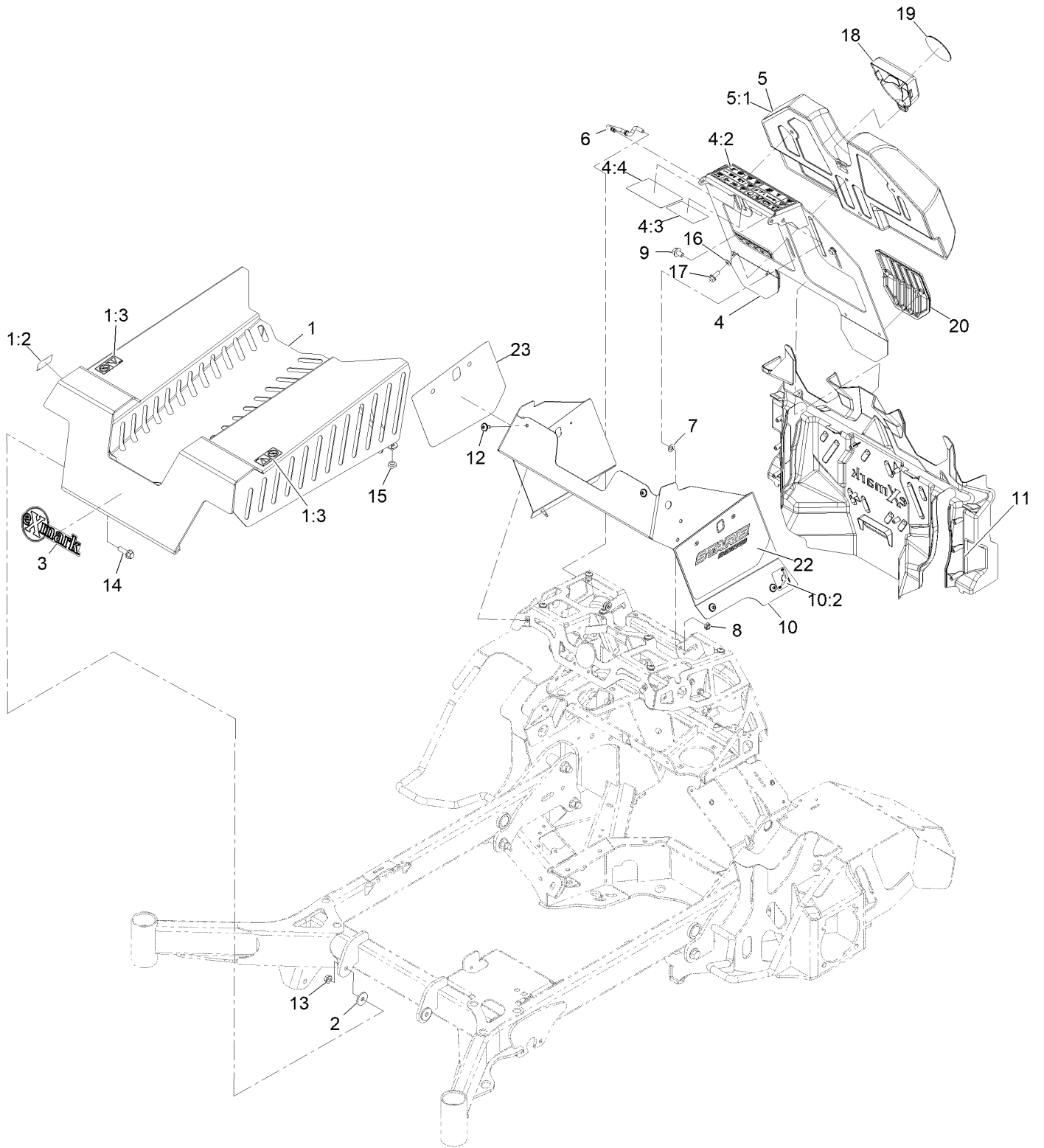

Guarding Assembly (continued)

<i>Ref.</i>	<i>Part Number</i>	<i>Qty.</i>	<i>Description</i>	<i>Ref.</i>	<i>Part Number</i>	<i>Qty.</i>	<i>Description</i>
1	135-2163	1	ASM, Front Cover W/ Decals	10	135-2164	1	ASM, Tower Skin W/ Decals
1:2	106-5517	1	Decal-Warning	10:2	116-5988	1	Decal-Park Brake, CE
1:3	119-6807	2	Decal-Warning	11	142-2752	1	Panel, Heat Deflector
2	107675	2	Washer	12	135-3494	6	Screw, Torx
3	126-6877	1	Decal, Exmark Logo	13	32128-21	2	Nut-3/8-16 Flanged Side Lock
4	135-2162	1	ASM, Pad Backing W/ Decals	14	119-4061	2	Screw-HHF 3/8-16 X 1 1/4
4:2	135-2412	1	Decal-Warning	15	1-513658	2	Bumper
4:3	116-8253	1	Decal-Drive Release	16	3290-475	3	Washer-Belleville
4:4	135-2266	1	Decal-Service Aid	17	100-1668	3	Screw-HHF
5	135-1320	1	Pad, Thigh	18	135-2596	1	Insert, Pad
5:1	135-6556	1	Cover, Pad	19	135-2714	1	Decal-X Logo Badge 3 In
6	135-1611	1	Rod, Prop	20	135-5107	2	Pad, Knee
7	131-8667	2	Washer-Thrust	22	135-6809	1	Decal-Staris Logo Lt
8	3296-59	2	Nut-Nyloc 3/8-16 Thin	23	135-6810	1	Decal-Staris Logo Rt
9	3234-9	2	Screw-HHF				

Park Brake Assembly

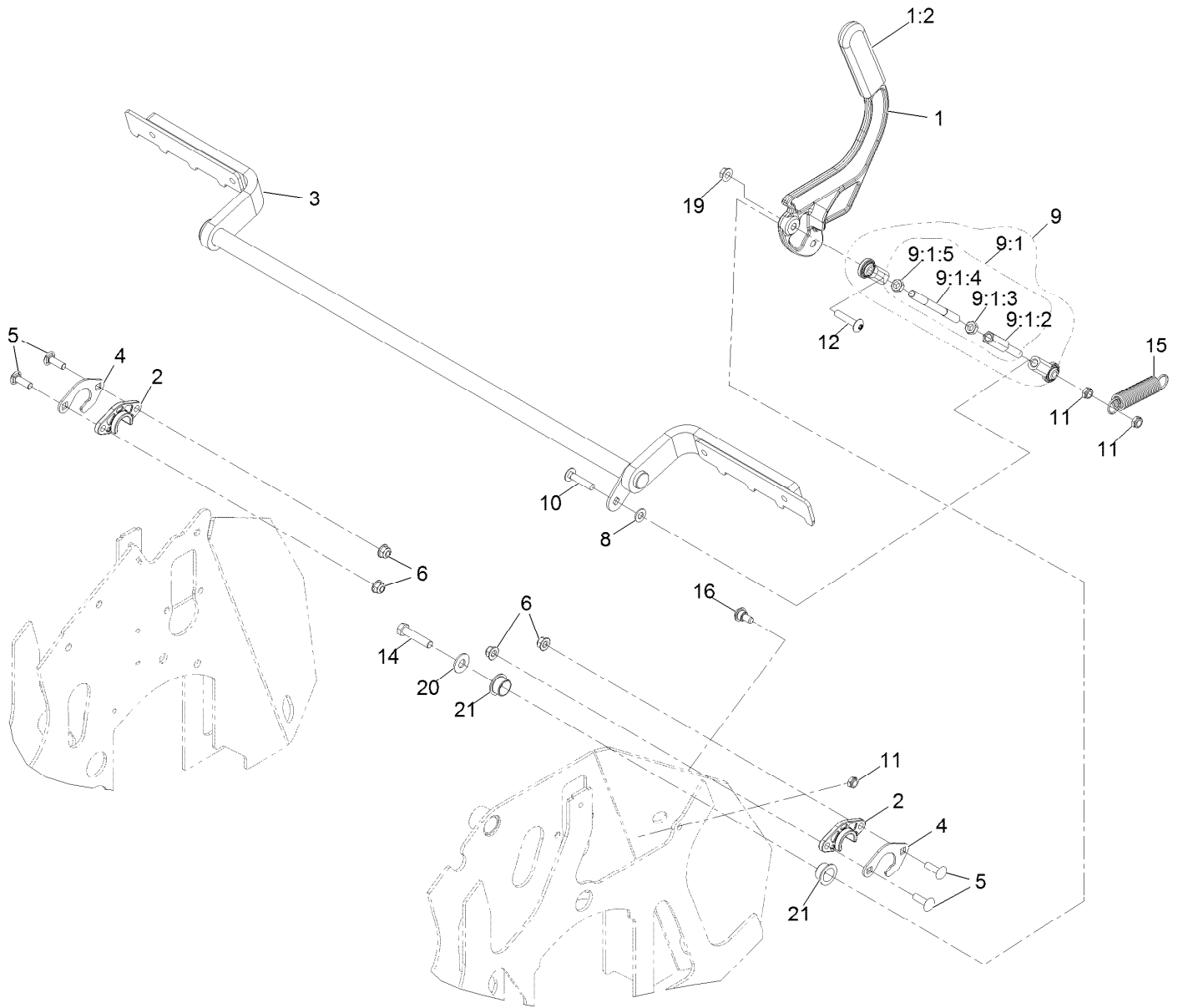

Park Brake Assembly (continued)

<i>Ref.</i>	<i>Part Number</i>	<i>Qty.</i>	<i>Description</i>	<i>Ref.</i>	<i>Part Number</i>	<i>Qty.</i>	<i>Description</i>
1	142-2413	1	ASM, Brake Lever W/ Grip	9:1:5	3220-3	1	Nut-Jam 3/8-24
1:2	1-633268	1	Grip-Lever	10	3230-4	1	Bolt-Carriage 5/16-18 X 1 1/2
2	115-5065	2	Bushing-Flange	11	3296-47	3	Nut-Nyloc 5/16-18 Thin
3	142-3739-03	1	Weld-Brake Shaft	12	126-7439	1	Screw-Truss HD 5-16-18 X 1 1/2 Torx Plus
4	135-7867	2	Support, Bearing	14	323-52	1	Screw-HH 3/8-16 X 1 3/4
5	3230-22	4	Bolt-Carriage 5/16-18 X 1 Sp	15	1-323161	1	Spring
6	104-8300	4	Nut-Nyloc 5/16-18 Flg	16	120-9471	1	Screw-Shoulder Bh 5/16-18 X 1/2 Tf Torx
8	3256-23	1	Washer-5/16 SAE	19	32128-25	1	Nut-Hex 5/16-18 Side Lock
9	135-7116	1	ASM, Linkage	20	3256-4	1	Washer-3/8 Std
9:1		1	ASM, Motion Control Link ●	21	135-7091	2	Bushing, Igus
9:1:2	116-4755	1	Rod-Adjustment				
9:1:3	3220-16	1	Nut-Jam 3/8-24 LH				
9:1:4	135-1291	1	Link, Motion Control				

● Not serviced separately

Drive Wheel Assembly

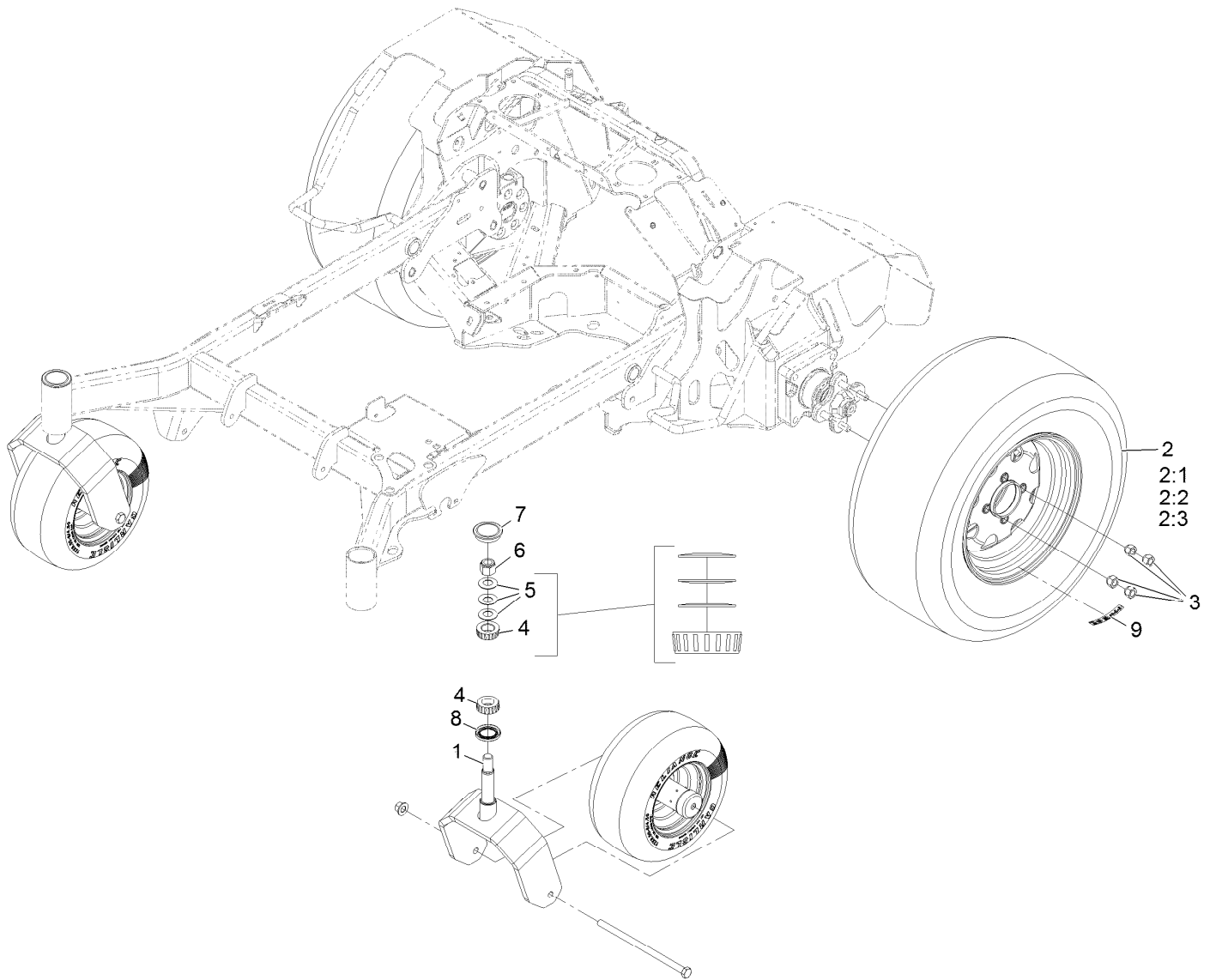

Drive Wheel Assembly (continued)

<i>Ref.</i>	<i>Part Number</i>	<i>Qty.</i>	<i>Description</i>	<i>Ref.</i>	<i>Part Number</i>	<i>Qty.</i>	<i>Description</i>
1		2	ASM, Caster, 12X6-6●	5	1-633508	6	Washer-Bellville
2	135-2215	2	ASM, Wheel And Tire	6	3296-51	2	Nut-Lock, NI
2:1	135-2216	1	Tire, 23 X 9.50-12	7	103-4882	2	Cap-Grease
2:2	135-2170	1	Rim, 12 X 7	8	116-5647	2	Seal-Grease
2:3	232-27	1	Stem-Valve	9	126-2055	2	Decal-Torque, Wheel Hub Lug
3	242-50	8	Nut-Lug				
4	1-543509	4	Bearing-Roller, Tapered				

● Not serviced separately

Caster Wheel Assembly

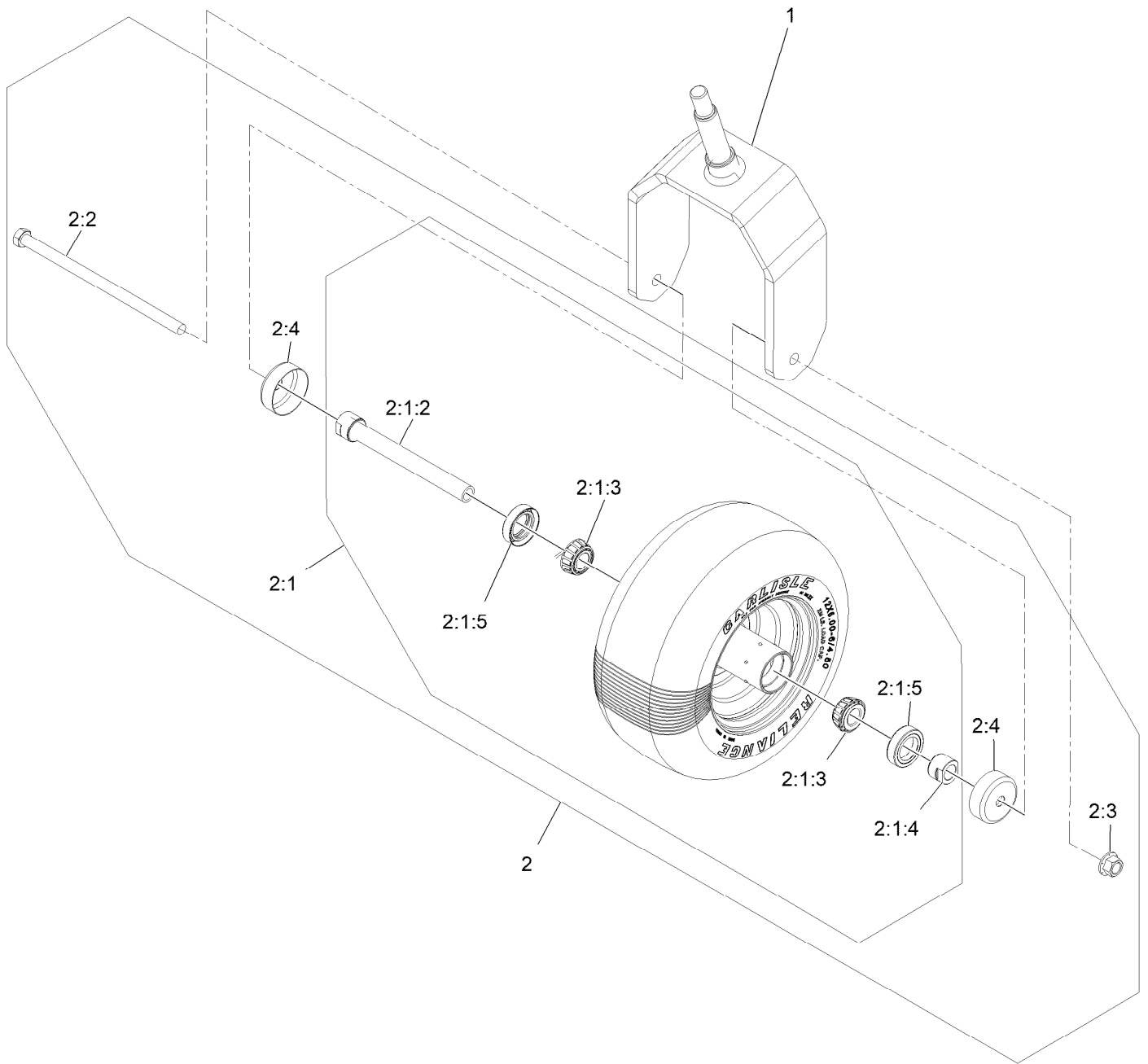

Caster Wheel Assembly (continued)

<i>Ref.</i>	<i>Part Number</i>	<i>Qty.</i>	<i>Description</i>	<i>Ref.</i>	<i>Part Number</i>	<i>Qty.</i>	<i>Description</i>
1	142-4254-01	1	Weld, Caster Fork	2:1:4	103-3051	1	Spacer-Nut
2	135-2148	1	ASM, Caster W/ Axle	2:1:5	103-0063	2	Seal-Double Lip
2:1		1	ASM, Caster W/ Bearings ●	2:2	325-39	1	Screw-HH 1/2-13 X 9 1/2
2:1:2	126-5361	1	Axle Caster ASM	2:3	99-5107	1	Nut-Lock 1/2-13
2:1:3	1-633585	2	Bearing-Cone Tapered Roller	2:4	103-2768	2	Guard-Seal

● Not serviced separately

Engine Assembly

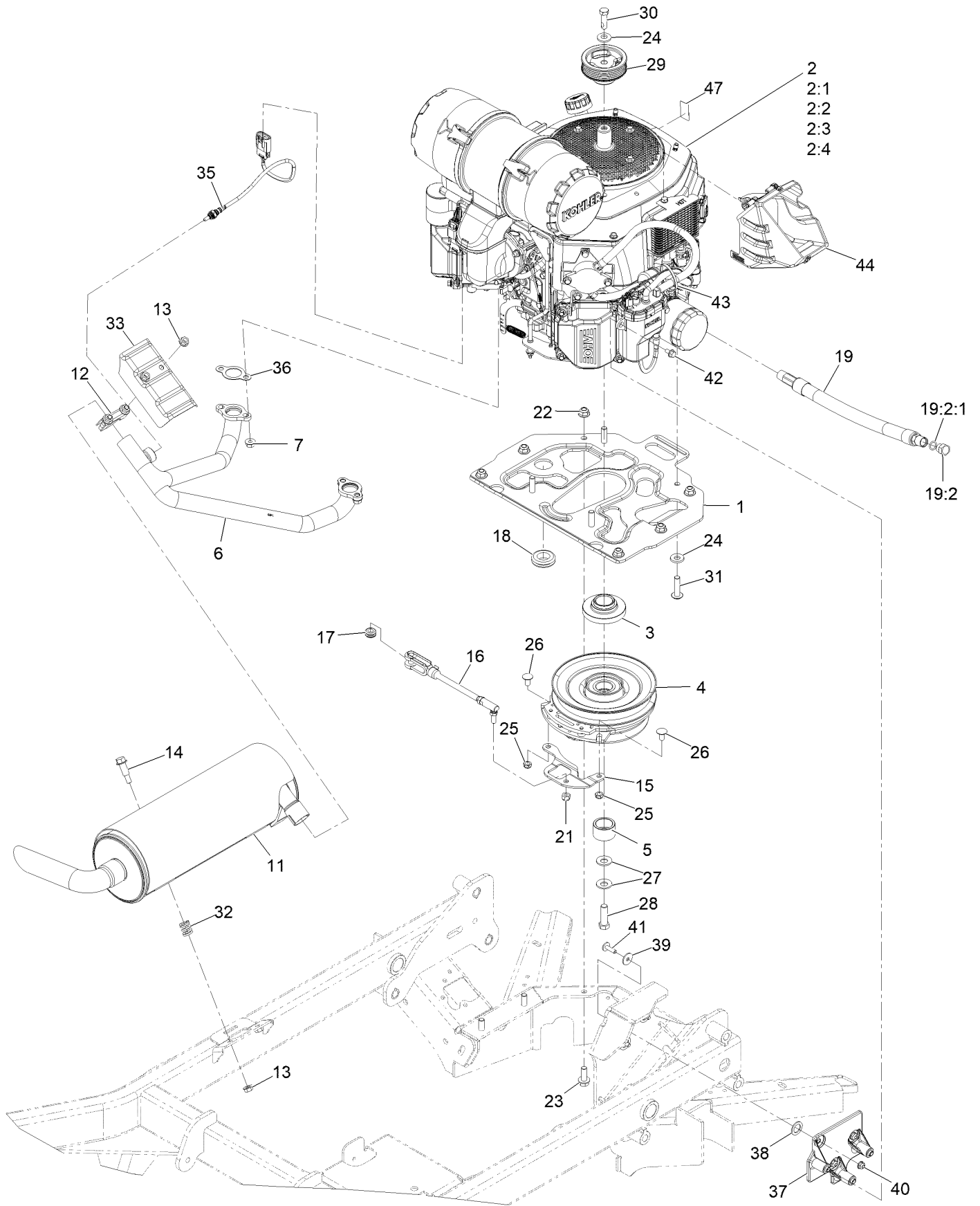

Engine Assembly (continued)

<i>Ref.</i>	<i>Part Number</i>	<i>Qty.</i>	<i>Description</i>	<i>Ref.</i>	<i>Part Number</i>	<i>Qty.</i>	<i>Description</i>
1	135-1615-03	1	Plate, Engine	21	3296-4	1	Nut-Lock 5/16-24
2		1	Engine, Kohler Cv730 EFI ▲◆	22	104-8301	6	Nut-Nyloc 3/8-16 Flg
2:1		1	Kohler 52 050 02-S Engine Oil Filter ▲◆	23	3234-42	6	Screw HHF 3/8-16 X 1
2:2		1	Kohler 25 083 01-S Engine Air Filter ▲◆	24	98-5975	5	Washer-Spring Disc 3/8
2:3		1	Kohler 25 083 04-S Safety Filter ▲◆	25	3296-47	2	Nut-Nyloc 5/16-18 Thin
2:4		1	Kohler 25 050 42-S Fuel Filter ▲◆	26	3230-18	2	Bolt-Carriage 5/16-18 X 5/8
3	142-3593	1	Spacer, Clutch 1.13	27	1-603610	2	Washer-Spring Disc 7/16
4	142-3587	1	Clutch	28	109-9761	1	Screw-HH 7/16-20 X 1 1/2 W/Loctite
5	135-1308	1	Spacer, Clutch	29	135-1198	1	Pulley, Crank
6	135-5095	1	Header, Kohler	30	135-7890	1	Screw-HH, Patch,
7	68-9400	4	Nut-Flange	31	126-0983	4	Screw-BHTF
11	142-3577	1	Muffler, 5"	32	135-6667	2	Spring, Compression
12	104-4090	1	Clamp-Muffler	33	135-7527	1	Shield, Heat
13	32128-25	4	Nut-Hex 5/16-18 Side Lock	35	135-6594	1	Sensor, Mini O2
14	130-2344	2	Bolt-Shoulder	36	110-6697	2	Gasket-Exhaust
15	135-1589	1	Strap, Clutch	37	136-6346	1	Bracket-Pump, Fuel
16	126-0620	1	ASM, Clutch Anchor	38	121-6840	3	Washer-Rubber
17	237-136	1	Grommet	39	3256-67	3	Washer
18	1-543286	1	Grommet	40	104-7201	3	Nut-Nyloc 1/4-20 Flg
19	116-5108	1	Oil Drain Hose ASM	41	126-6269	3	Screw-Truss
19:2	353-508	1	Plug-W/O-Ring ■	42	33103-012	3	Screw-HHF
19:2:1	237-42	1	O-Ring	43	3290-378	2	Tie-Cable ●
				44	135-6621	1	Duct, Air
				47	135-6844	1	Decal-10W-50 Oil

● Not illustrated
▲ Not serviced separately

■ Torque to 24-26 ft-lb
◆ Obtain parts from www.kohlerplus.com

Fuel Assembly (continued)

<i>Ref.</i>	<i>Part Number</i>	<i>Qty.</i>	<i>Description</i>	<i>Ref.</i>	<i>Part Number</i>	<i>Qty.</i>	<i>Description</i>
1	135-2227	1	ASM, Rt Fuel Tank	15	104-7201	3	Nut-Nyloc 1/4-20 Flg
2	135-7299	2	Clamp, Tank	16	135-2219	1	Line, Vent, Main
3	3296-59	4	Nut-Nyloc 3/8-16 Thin	17	135-2221	1	Line, Vent, Right
4	135-2225	1	ASM, Lt Fuel Tank	18	135-7097	1	Line, Vent, Left
5	142-3597	1	ASM, Left Fuel Line	19	51-3216	5	Hose-Fuel
6	142-3598	1	ASM, Right Fuel Line	20	135-2222	1	Fitting, 3/16" Y
7	135-2203	1	Fitting, 2603-4-4-4	21	32180-030	4	Clip-Tie
9	142-3600	1	ASM, Koh Fuel Line	22	133-8062	1	Decal-Arrestor, Spark
10	32144-10	5	Screw-HWH 1/4-20 X .62	23	135-3950	1	Hose, Vent
11	135-1928-03	1	Bracket, Carbon Canister	29	106-8150	1	Fitting-Straight
12	116-1442	1	Canister-Carbon, 1200Cc	30	105-8342	1	Hose-Fuel
13	116-2228	1	Clamp, T-Bolt	33	119-4235	2	Hose-Vent, Formed
14	321-39	3	Screw-HH	34	133-8499	1	Valve-Check, Vacuum

Left Fuel Tank Assembly

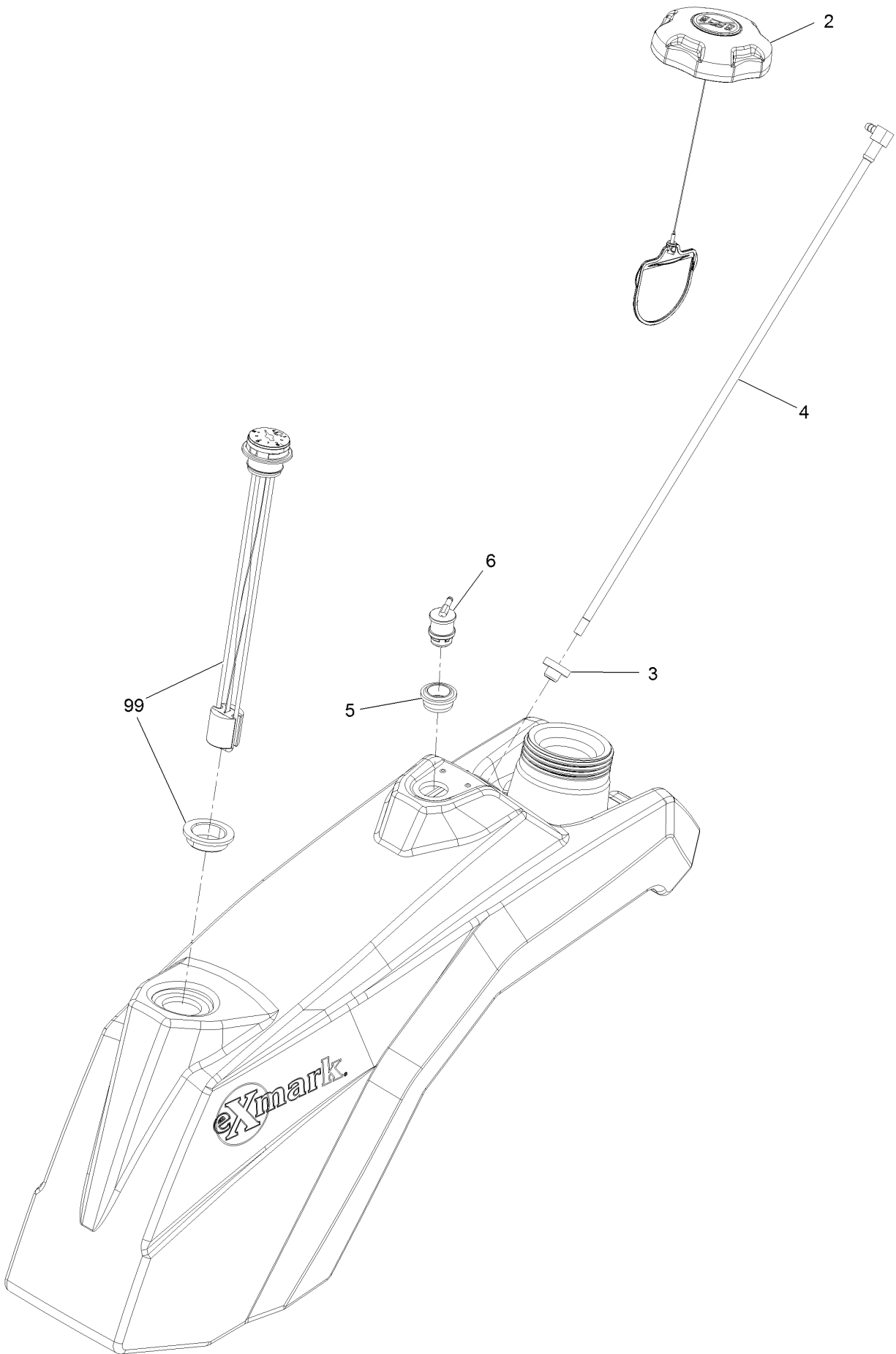

Left Fuel Tank Assembly (continued)

<i>Ref.</i>	<i>Part Number</i>	<i>Qty.</i>	<i>Description</i>	<i>Ref.</i>	<i>Part Number</i>	<i>Qty.</i>	<i>Description</i>
2	137-4119	1	Cap-Fuel, Ratcheting	5	114-0284	1	Grommet
3	46-6560	1	Bushing	6	119-3547	1	Valve-Vent, Fuel
4	135-1916	1	Straw, Fuel, Short	99	135-3987	1	Kit, Fuel Gauge

Left Fuel Line Assembly

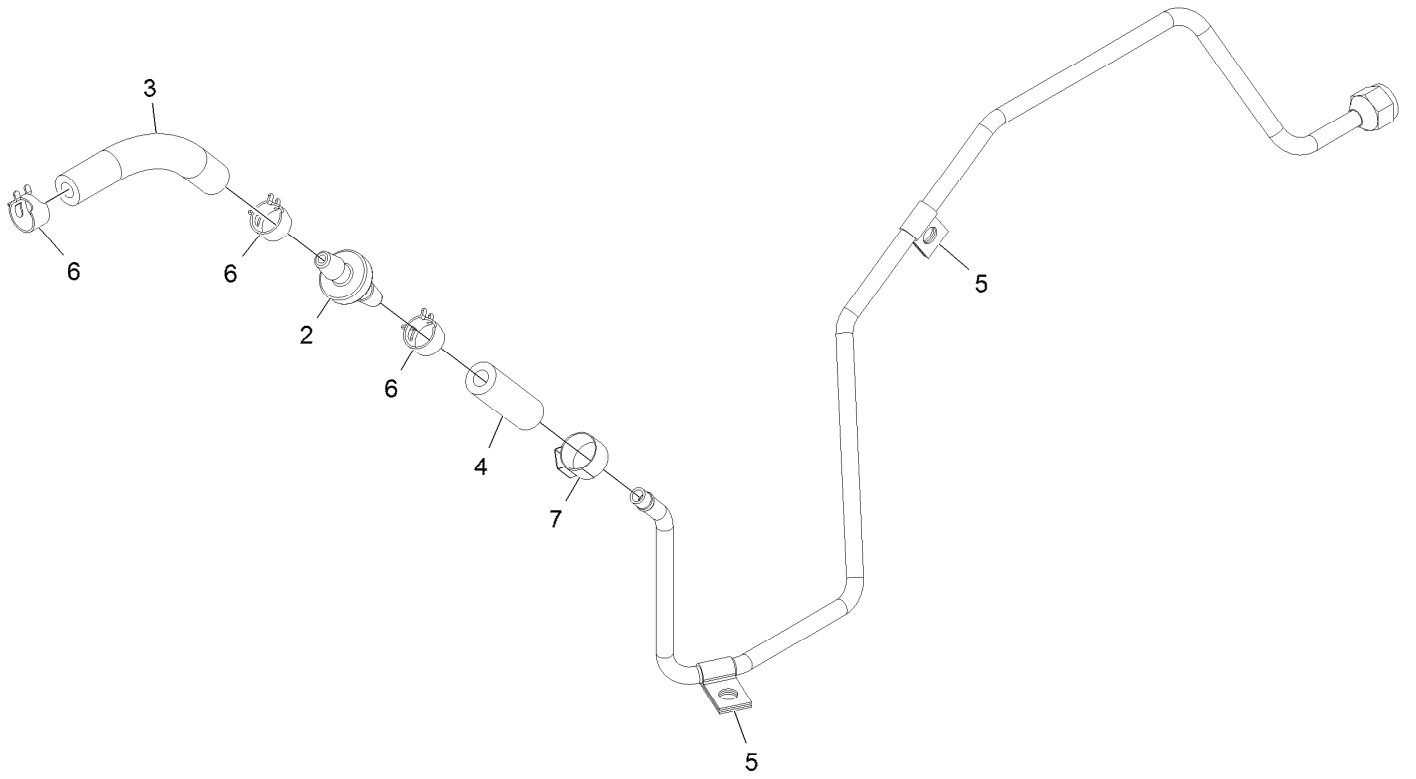

Left Fuel Line Assembly (continued)

<i>Ref.</i>	<i>Part Number</i>	<i>Qty.</i>	<i>Description</i>	<i>Ref.</i>	<i>Part Number</i>	<i>Qty.</i>	<i>Description</i>
2	99-5000	1	Valve-Check, Fuel	5	2412-72	2	Clip-Closed, Insulated
3	105-8342	1	Hose-Fuel	6	2412-98	3	Clamp-Hose
4		1	Hose-Fuel ●	7		1	Clamp-Hose, Fuel ●

● Not serviced separately

Right Fuel Tank Assembly

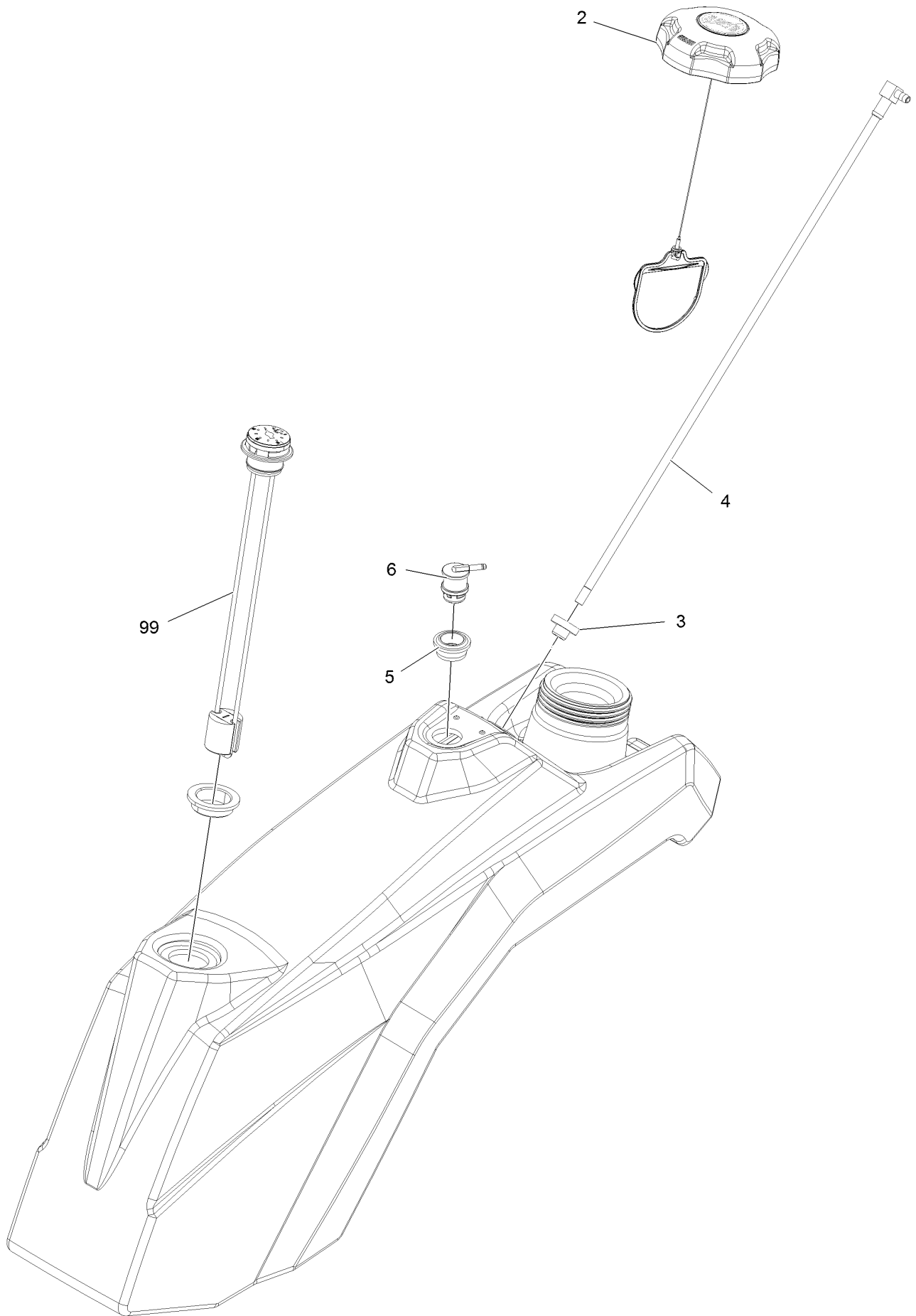

Right Fuel Tank Assembly (continued)

<i>Ref.</i>	<i>Part Number</i>	<i>Qty.</i>	<i>Description</i>	<i>Ref.</i>	<i>Part Number</i>	<i>Qty.</i>	<i>Description</i>
2	137-4119	1	Cap-Fuel, Ratcheting	5	114-0284	1	Grommet
3	46-6560	1	Bushing	6	119-3547	1	Valve-Vent, Fuel
4	135-1916	1	Straw, Fuel, Short	99	135-3987	1	Kit, Fuel Gauge

Right Fuel Line Assembly

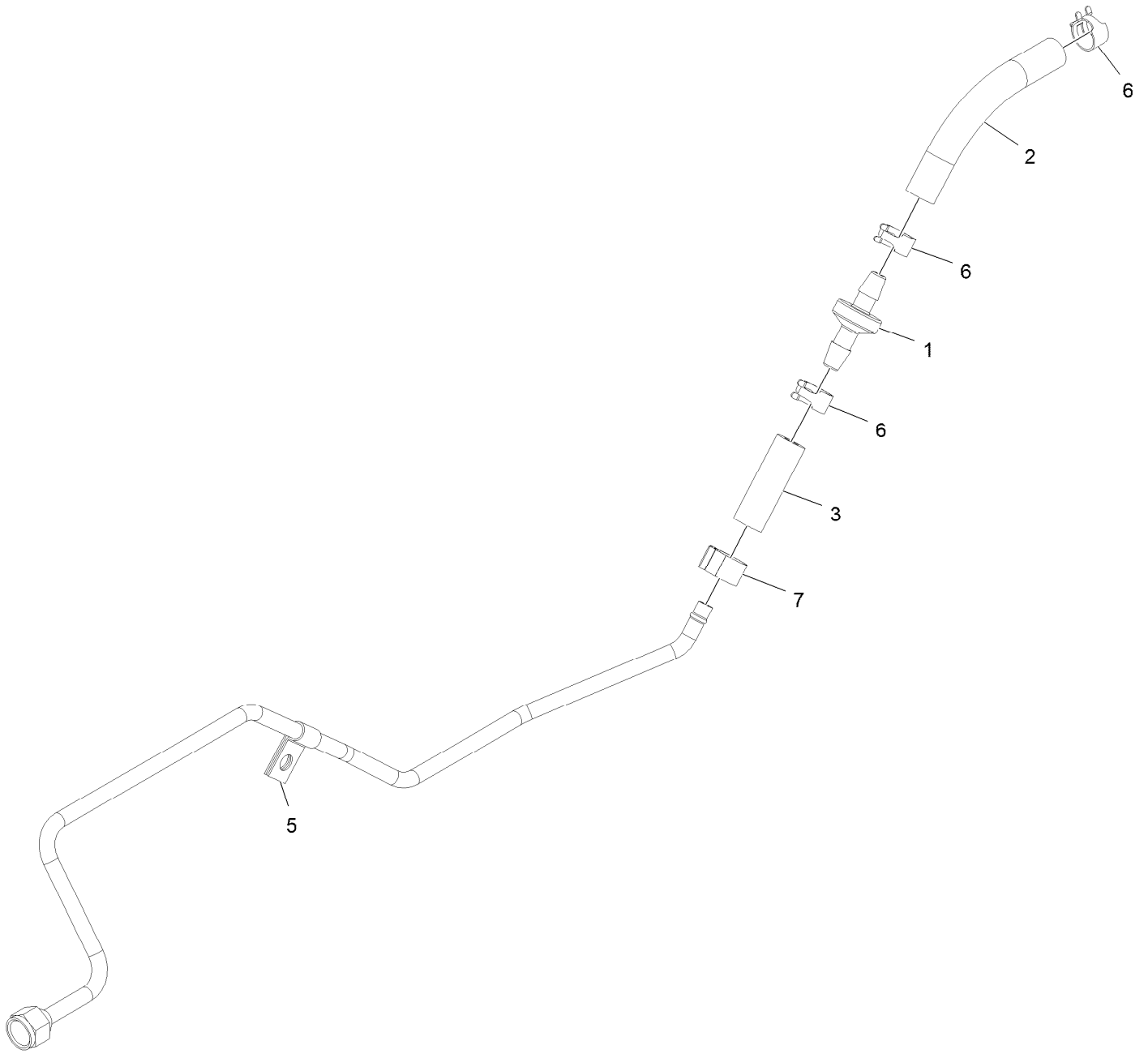

Right Fuel Line Assembly (continued)

<i>Ref.</i>	<i>Part Number</i>	<i>Qty.</i>	<i>Description</i>	<i>Ref.</i>	<i>Part Number</i>	<i>Qty.</i>	<i>Description</i>
1	99-5000	1	Valve-Check, Fuel	5	2412-72	1	Clip-Closed, Insulated
2	105-8342	1	Hose-Fuel	6	2412-98	3	Clamp-Hose
3		1	Hose-Fuel ●	7		1	Clamp-Hose, Fuel ●

● Not serviced separately

Fuel Line Assembly

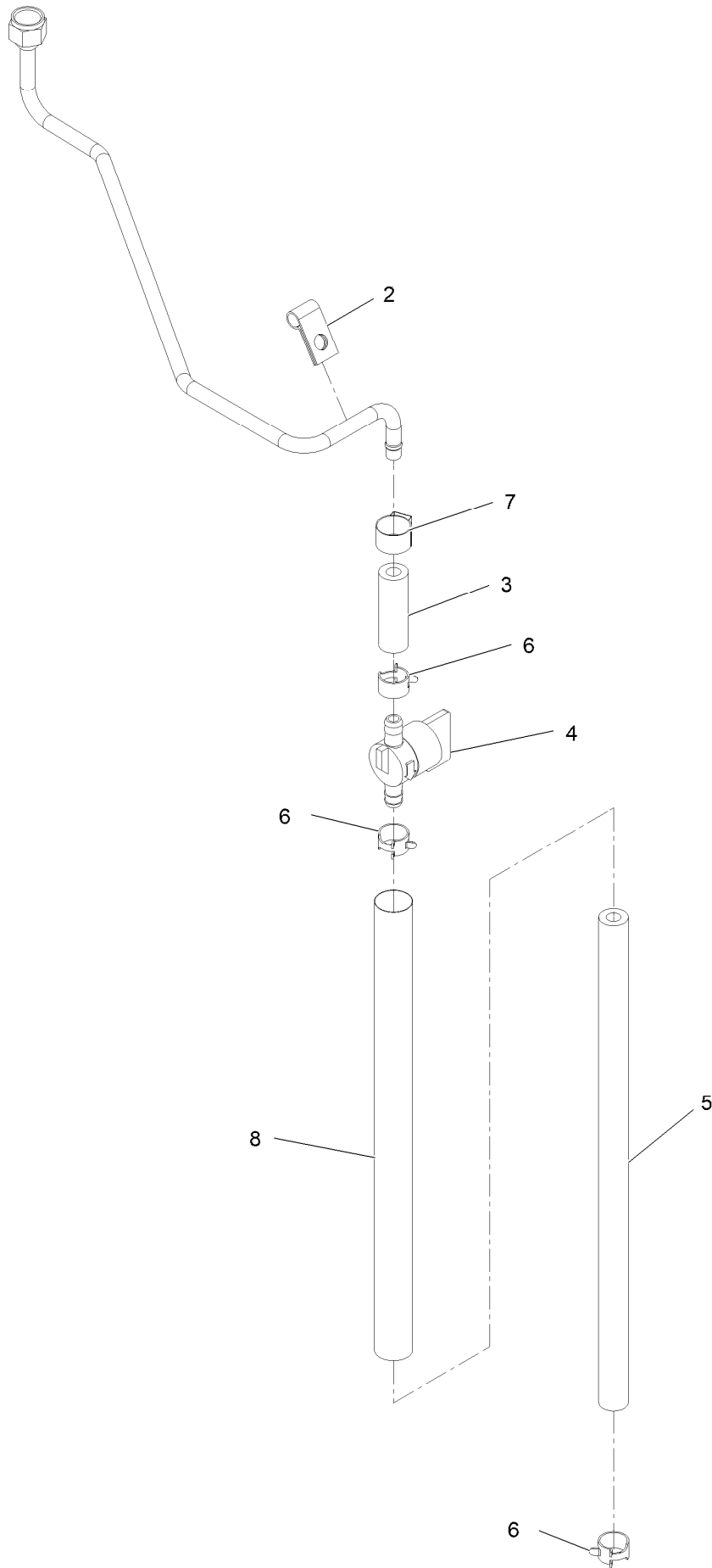

Fuel Line Assembly (continued)

<i>Ref.</i>	<i>Part Number</i>	<i>Qty.</i>	<i>Description</i>	<i>Ref.</i>	<i>Part Number</i>	<i>Qty.</i>	<i>Description</i>
2	2412-72	1	Clip-Closed, Insulated	6	2412-98	3	Clamp-Hose
3		1	Hose-Fuel ●	7		1	Clamp-Hose, Fuel ●
4	1-603770	1	Valve-Fuel	8	135-6549	1	Sleeve, Thermal
5	109-0282	1	Hose-Fuel				

● Not serviced separately

Hydraulic Assembly (continued)

<i>Ref.</i>	<i>Part Number</i>	<i>Qty.</i>	<i>Description</i>	<i>Ref.</i>	<i>Part Number</i>	<i>Qty.</i>	<i>Description</i>
1	135-1162	1	Motor, TI195	15	135-1270	1	ASM, Idler Arm
2	142-2933	1	Pump, 12Cc	16	135-1272	1	Spring, Extension
2:1	126-2479	1	Kit, 10Cc/12Cc Pump Kit	17	142-2968	2	Pulley, Pvk5
2:2	105-6184	1	Seal Overhaul Kit	18	135-1196	1	Belt, Pvk5
3	142-2934	1	Pump, 12Cc	19	142-6813	2	Kit-Sts Hose- HYD
3:1	126-2479	1	Kit, 10Cc/12Cc Pump Kit	20	142-6814	2	Kit-Sts Hose- HYD
3:2	105-6184	1	Seal Overhaul Kit	23	116-1399	2	Locknut
4	135-3305	1	ASM, Hydraulic Reservoir	24	119-1065	2	Screw-HWH
4:3	142-2793	1	Cap, Hydraulic	25	3232-3	4	Bolt-Carriage 7/16-14 X 1 1/2
4:3:1	142-2792	1	O-Ring	26	114-8417	4	Nut-HF, NI
5	340-98	4	Fitting-Elbow, 90 DEG	27	1-513435	8	Washer-Spring Disc 1/2
5:1	237-79	1	O-Ring	28	325-10	8	Screw-HH 1/2-13 X 2 1/2
5:2	237-30	1	O-Ring	29	3290-510	8	Nut-Square
6	340-77	4	Fitting-Elbow, 90 DEG	30	135-7971	2	Key, 5Mm X 5Mm X 29Mm
6:1	237-22	1	O-Ring	31	3241-7	4	Screw-SQH 1/4-20 X 1/2
6:2	237-42	1	O-Ring	32	3296-56	2	Nut-Nyloc 1/4-20 Thin
7	340-89	4	Fitting-HYD, 45 DEG	33	32105-15	2	Screw-Machine 1/4-20 X 3/4
7:1	237-30	1	O-Ring	35	340-99	2	Fitting-HYD, 90 DEG
7:2	237-80	1	O-Ring	35:1	237-30	1	O-Ring
8	142-2951	1	ASM, Filter Head	35:2	237-42	1	O-Ring
8:2	109-4180	1	Element, Oil Filter	36	73-0041	2	Washer-Thrust
8:3	340-96	2	Adapter	37	142-2840	1	Motor, TI195
8:3:1	237-30	1	O-Ring	99	105-6184	1	Seal Overhaul Kit ●
8:3:2	237-42	1	O-Ring	99	126-2479	1	Kit, 10Cc/12Cc Pump Kit ●
9	135-7056	1	Line, Hydraulic, Case Tee	99	130-1788	1	Seal Kit ●
10	135-7054	1	Line, Hydraulic, Case	99:1		5	Seal-Ring, Viton ●■
11	135-7055	1	Line, Hydraulic, Charge Tee	99:2		1	Seal-Commutator ●■
12	135-7053	1	Line, Hydraulic, Charge	99:3		1	Seal-Dirt/Water, Hi Temp ●■
13	135-2214	2	ASM, Hub W/ Studs	99:4		1	Seal-Shaft ●■
13:2	116-1696	4	Stud-Wheel				
14	135-7052	1	Line, Hydraulic, Supply				

● Not illustrated

■ Not serviced separately

Idler Arm Assembly

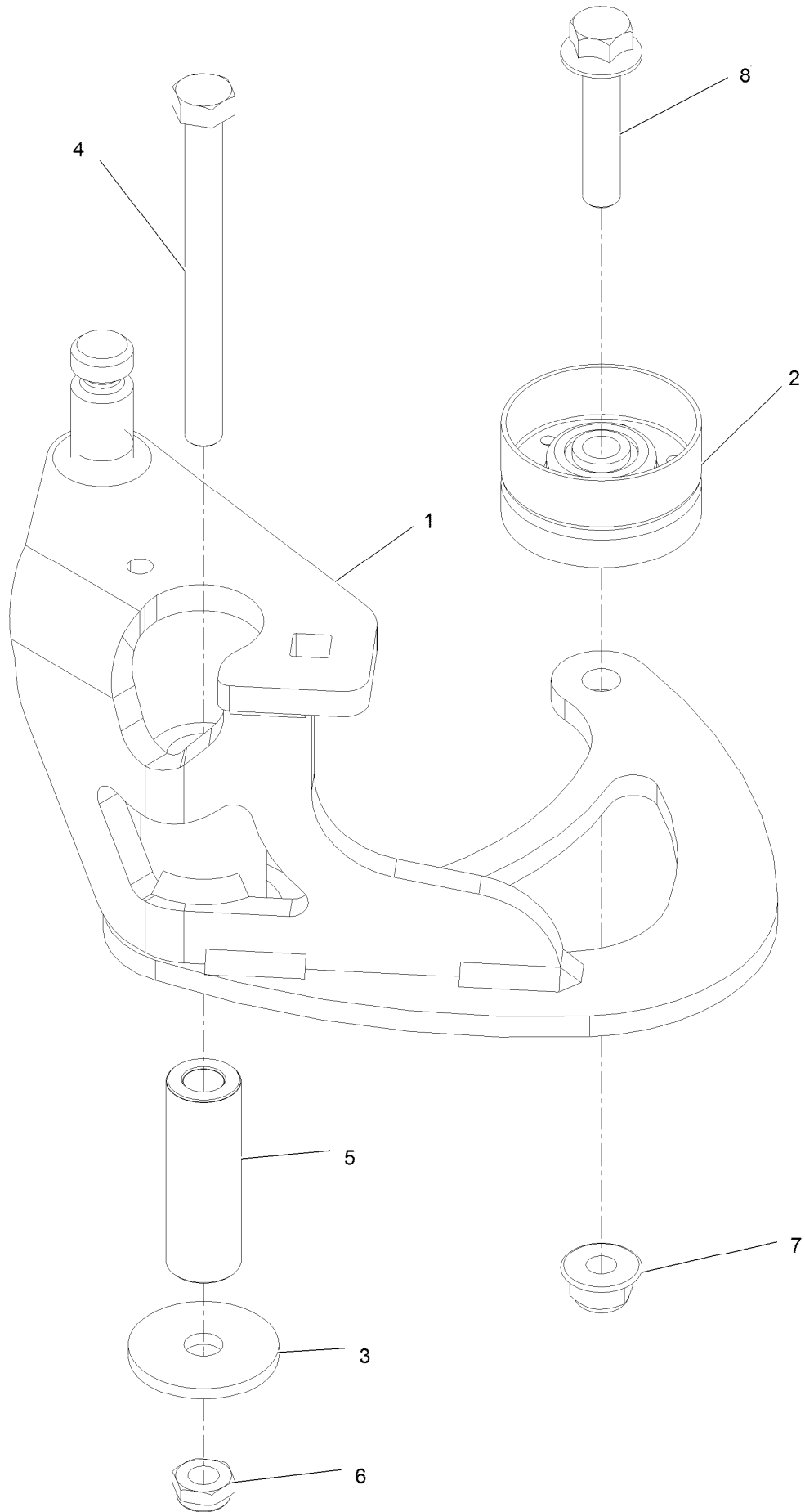

Idler Arm Assembly (continued)

<i>Ref.</i>	<i>Part Number</i>	<i>Qty.</i>	<i>Description</i>	<i>Ref.</i>	<i>Part Number</i>	<i>Qty.</i>	<i>Description</i>
1	135-2238	1	ASM, Idler Arm W/ Bushings	5	135-1273	1	Tube, Idler Pivot
2	135-1199	1	Idler, Flat	6	3296-59	1	Nut-Nyloc 3/8-16 Thin
3	1-213069	1	Washer	7	104-8301	2	Nut-Nyloc 3/8-16 Flg
4	323-16	1	Screw-HH 3/8-16 X 4	8	3234-19	1	Screw-HHF 3/8-16 X 1 3/4

Electrical Assembly

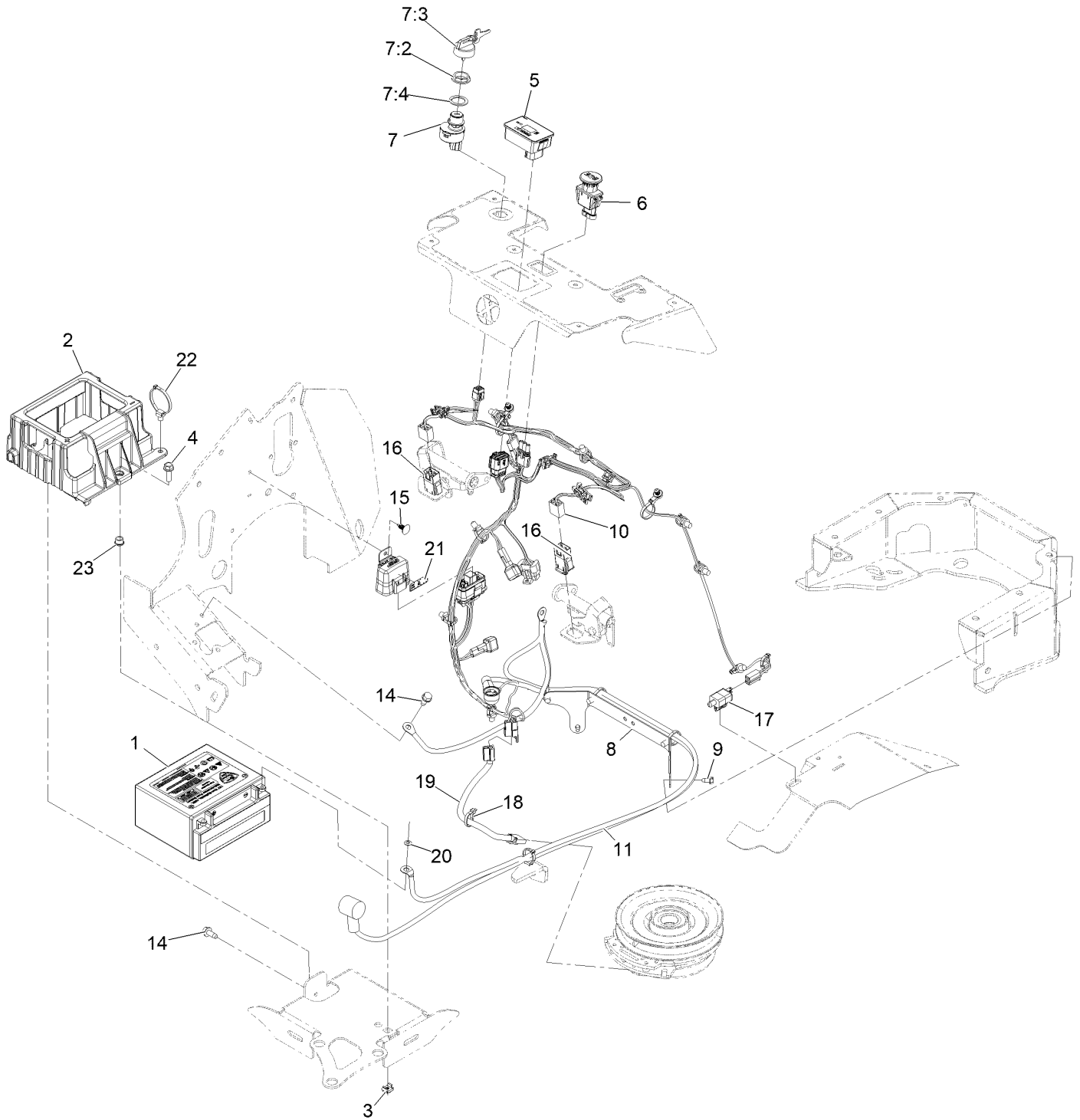

Electrical Assembly (continued)

<i>Ref.</i>	<i>Part Number</i>	<i>Qty.</i>	<i>Description</i>	<i>Ref.</i>	<i>Part Number</i>	<i>Qty.</i>	<i>Description</i>
1	135-4421	1	Battery, Agm, Non-Spillable	11	135-2126	1	Harness-Battery
2	142-2450	1	Box, Battery	14	32144-11	2	Screw-HWH 5/16-18 X 3/4 Tf
3	135-4473	1	Nut, Snap	15	117-2382	1	Plug-Plastic
4	115-5142	1	Screw-HHF	16	104-3338	2	Switch-Delta
5	135-7189	1	Module-Hour Meter	17	110-6765	1	Switch
6	126-6187	1	Switch-PTO, Sealed	18	3290-378	1	Tie-Cable
7	126-6285	1	Ignition Switch ASM	19	109-9274	1	Harness-Clutch
7:2	108-8660	1	Nut-Mounting	20	1-303435	2	Washer-Spring Disc 1/4
7:3	106-5270	1	Ignition Key Set	21	126-7875	1	Decal-Fuse
7:4	108-8659	1	Washer-Backup	22	32180-030	1	Clip-Tie
8	135-1924-03	1	Support, Battery Cable	23	256-116	1	Bushing-Flange
9	32104-17	2	Screw-HWH 1/4-20 X 1/2 Tap	99	135-7732	1	Hardware Kit, Battery ●
10	142-2406	1	Harness-Wire ■				

● Not illustrated

■ Use dielectric grease on all unsealed connectors and terminals only. Do not apply in sealed connectors.

Harness Assembly

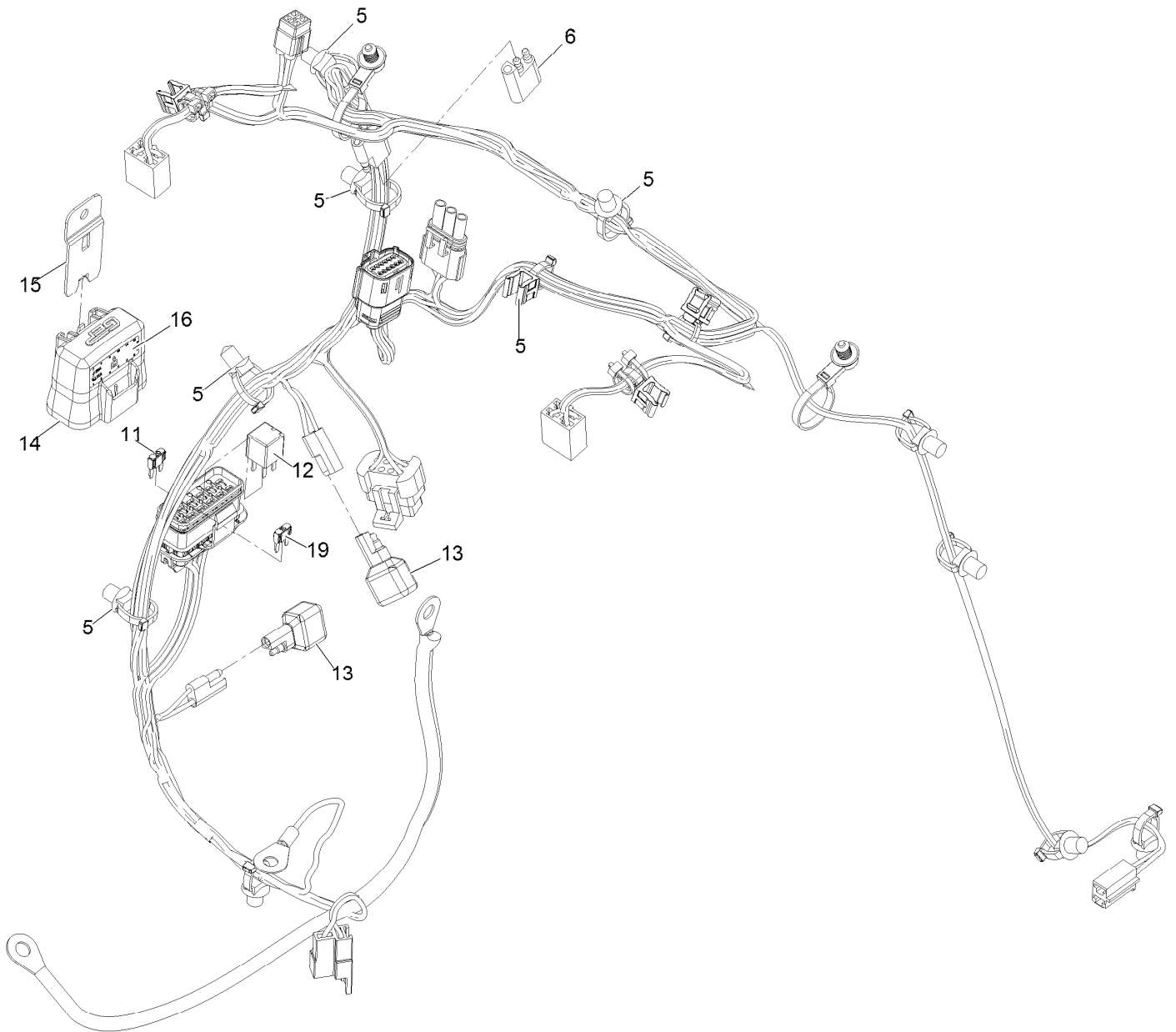

Harness Assembly (continued)

<i>Ref.</i>	<i>Part Number</i>	<i>Qty.</i>	<i>Description</i>	<i>Ref.</i>	<i>Part Number</i>	<i>Qty.</i>	<i>Description</i>
5	32180-030	10	Clip-Tie	14	32180-176	1	Cover-Block, Fuse
6	32180-197	1	Cap-Plug	15	32180-177	1	Clip-Mounting
11	121-8868	1	Fuse-Mini Blade, 20 Amp	16	126-7875	1	Decal-Fuse
12	126-3991	1	Relay-Micro	19	121-8867	1	Fuse-Mini Blade, 15 Amp
13	100-4918	2	Diode				

Notes:



MAXIMIZE THE PERFORMANCE OF YOUR EXMARK MACHINE.



EXMARK® PREMIUM ENGINE OIL

Exmark now offers a family of engine oil viscosities to perform well in any environment. Each viscosity has the same synthetic formulation to give you what you need in punishing conditions. We designed each grade to the highest quality, making it ideal even for diesel applications. Coupled with Exmark Premium Fuel Treatment, we have the performance products to make your machine hum.

EXMARK PREMIUM ENGINE OIL SAE 30/10W-30

- Meets zero shear requirements of a straight grade SAE 30 as well as the cold temp properties of a 10W-30.
- Most versatile oil in the industry.
- Superior corrosion protection over conventional oil - even in corrosive, humid environments.

EXMARK PREMIUM ENGINE OIL SAE 20W-50

- Perfect for your big block engine, or any application in severe service.
- Same full synthetic formulation as all other Exmark Premium viscosities.
- Also effective for use in severe service small block engines.

EXMARK PREMIUM ENGINE OIL SAE 10W-50

- Full synthetic formulation gives you peak performance. Don't settle for less.
- Wide span multi-grade combines easy starting in cold weather with maximum protection in high temperature operation.
- Reduce friction & wear over standard mineral formulations.

EXMARK PREMIUM ENGINE OIL SAE 0W-40

- The perfect choice for when the weather turns cold or unpredictable, and your Exmark UTV has to perform.
- Commercial quality for severe service.
- Advanced additive package helps prevent corrosion from long-term storage.

EXMARK PREMIUM ENGINE OIL UTV FORMULATION

- 4-cycle high-temp formulation.
- Heavier viscosity, full synthetic, perfect for your UTV.

EXMARK PREMIUM UTV EXTREME CONDITIONS GEAR OIL

- SAE 80W-90, designed to keep your UTV performing at its peak.
- Shear stable, hypoid gear lube.
- Includes a premium additive system to combat wear, oxidation, rust & corrosion.

Available from your local Exmark dealer. Find your closest dealer at exmark.com

EXMARK ACCESSORIES AND OPTIONS*

MID-MOUNT RIDING ACCESSORIES AND OPTIONS

CUSTOM RIDE SEAT SUSPENSION SYSTEM	OPERATOR CONTROLLED DISCHARGE
FULL SUSPENSION SEAT	SUN SHADE
DECK LIFT ASSIST KIT	TRASH CONTAINER
HITCH KIT	TURF STRIPER
LIGHT KIT	ULTRA VAC COLLECTION SYSTEM
12V POWER PORT	ULTRA VAC QUICK DISPOSAL SYSTEM
MICRO-MULCH SYSTEM	

OUT-FRONT RIDING ACCESSORIES AND OPTIONS

CUSTOM RIDE SEAT SUSPENSION SYSTEM	SNOW BLADE
DUAL-TAIL WHEEL	SNOWBLOWER
FLOOR PAN EXTENDER	SUN SHADE
HITCH KIT	TRASH CONTAINER
LIGHT KIT	ULTRA VAC COLLECTION SYSTEM
MICRO-MULCH SYSTEM	ULTRA VAC QUICK DISPOSAL SYSTEM
ROLL OVER PROTECTION SYSTEM (ROPS)	WEATHER CAB

WALK-BEHIND ACCESSORIES AND OPTIONS

GRASS CATCHER	TURF STRIPER
MICRO-MULCH SYSTEM	STANDON

*Some accessories and options not available for some models.

Place Model No. and Serial No.
Label Here (Included in the Literature
Pack) or Fill in Below

Model No. _____

Serial No. _____

Date Purchased _____

Engine Model No. and Spec. No. _____

Engine Serial No. (E/No) _____

© 2021 Exmark Mfg. Co., Inc.
415 Industrial Row
Beatrice, NE 68310
All Rights Reserved

Part No. 4505-323 Rev. A
(402) 223-6375
Fax (402) 223-5489
Printed in the USA.

