

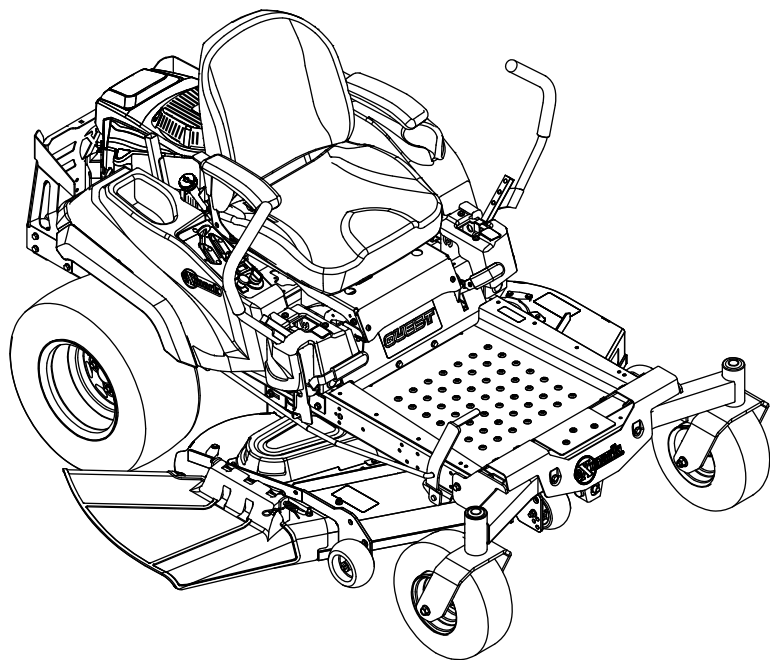

QUEST®

Model No. QZS708GEM50200—Serial No. 406294345 and Up

Picture below may not reflect actual product.



Parts Manual

Part No. 4504-746 Rev. A

Ordering Replacement Parts

To order replacement parts, please supply the part number, the quantity, and the description of each part desired.

Understanding Reference Numbers

Each identified part in an illustration has a reference number. The reference number for a part also appears in the parts list, along with other information about the part.

This catalog uses two special reference number formats, one to indicate parts in a service assembly and another to indicate the quantity of a given part in an illustration.

Service Assembly Reference Numbers

Parts in service assemblies have reference numbers in the form a:b. The a represents the reference number of the entire service assembly and the b represents a sequential number unique to each part within the service assembly.

For example, a wheel assembly might be identified by reference number 6, the tire by 6:1, the valve by 6:2, and the wheel by 6:3. When you order the assembly identified by reference number 6, you receive all parts identified by reference numbers 6:1, 6:2, and 6:3. However, you may also order any part individually. Reference numbers of this type appear in illustration and in parts lists.

Reference Numbers Indicating Quantity

In an illustration, if a reference number indicates more than one part, the reference number has the form nX y. The n represents the quantity of the part, the X is the multiplication symbol, and the y represents the reference number.

For example, in an illustration, the reference number 2X 37 means that two of the parts identified by reference number 37 are indicated.

Touch Up Paint

Exmark black touch up spray paint – gloss black.

Exmark red touch up paint (spray paint – P/N 1-850337 - .6 oz liquid bottle – P/N 103-9140).



If your Exmark dealer does not have the Exmark part in stock, Exmark will get the parts to the dealer the next business day or the part will be FREE Guaranteed!! (Some restrictions apply. See your participating Exmark Dealer for details.)

Contents

Deck Assembly	4
50 Inch Deck and Decal Assembly	6
Main Frame Assembly	8
Main Frame Assembly W/Decals	10
Deck Lift Assembly	12
Tire and Wheel Assembly	14
Park Brake Assembly	16
Rear Tire Assembly	18
Seat Assembly	20
Seat Assembly (cont)	22
Motion Control Assembly	24
Fuel Assembly	26
Engine Assembly	28
Engine W/Decal Assembly	30
Clutch Assembly	32
Fuel System Assembly with Non-Canister Style Air Filter	34
Carburetor Assembly	36
Air Intake and Filtration Assembly	38
Ignition and Cooling Fan	40
Crankcase and Crankshaft Assembly	42
Governor Control Assembly	44
Piston and Cylinder Head Assembly	46
Blower Housing Assembly	48
Gasket and Seal Kit	50
Transaxle Drive	52
Left Hand Hydro Transaxle Assembly	54
Right Hand Hydro Transaxle Assembly	56
Electrical Assembly	58

Deck Assembly

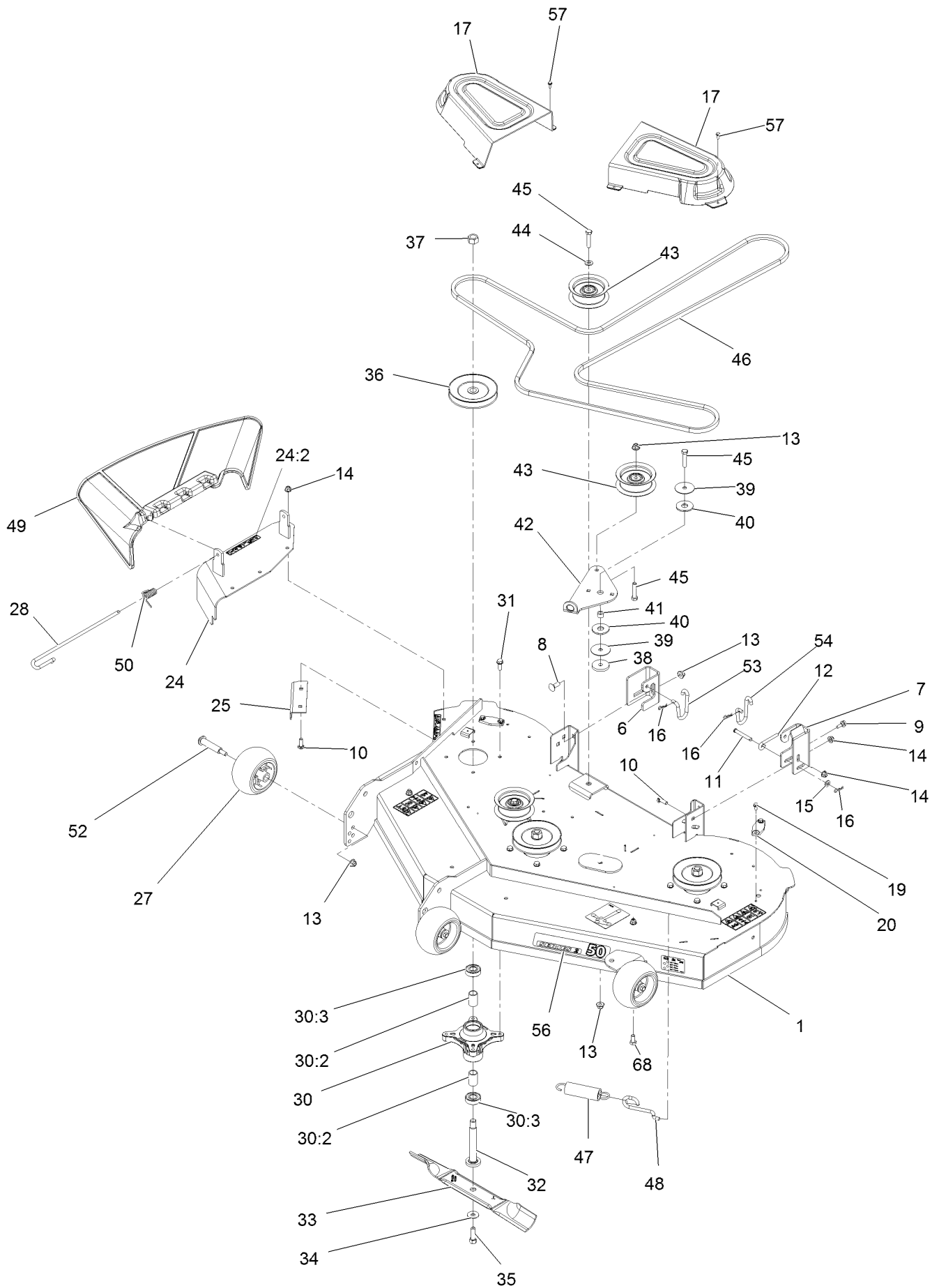

Deck Assembly (continued)

<i>Ref.</i>	<i>Part Number</i>	<i>Qty.</i>	<i>Description</i>	<i>Ref.</i>	<i>Part Number</i>	<i>Qty.</i>	<i>Description</i>
1	135-1073	1	Deck-50 W/Decals	32	117-7268	3	Shaft-Spindle
6	138-7253	1	Bracket-Hanger, Right Rear	33	115-5059-03	3	Blade-Hi Lift
7	131-3935	1	Bracket-Hanger, LH	34	3290-465	3	Washer-Spring Disc
8	3231-2	2	Bolt-Carriage 3/8-16 X 1	35	26-0671	3	Screw-HH 7/16-20 X 1.36 Gr8
9	120-7024	1	Screw-HH Flg 1/4-20 X 3/4 Tf	36	125-5575	3	Pulley
10	3230-22	5	Bolt-Carriage 5/16-18 X 1 Sp	37	3219-6	3	Nut-Hex 5/8-18
11	110-0618	1	Pin-Clevis	38	110-9981	1	Washer-Plain
12	138-7255	1	Rod-Level, Deck	39	120-2229	2	Washer
13	104-8301	7	Nut-Nyloc 3/8-16 Flg	40	114-0463	2	Washer-Friction, Composite
14	104-8300	8	Nut-Nyloc 5/16-18 Flg	41	115-4986	1	Spacer
15	3256-23	1	Washer-5/16 SAE	42	138-7262	1	Arm-Idler
16	1-806003	3	Hairpin-Cotter	43	132-9420	3	Pulley-Idler, Flat
17	108-7890	2	Cover-Belt	44	3256-24	2	Washer-3/8 SAE
19	32144-4	4	Screw-HWH 1/4-20 X 1/2 Taptite	45	323-9	4	Screw-HH 3/8-16 X 1 3/4
20	136-4171	2	Cover-Washout Port	46	119-8820	1	V-Belt
24	131-3962	1	Cover ASM W/Decal	47	1-603414	1	Spring-Extension
24:2	93-7009	1	Decal-Danger	48	138-7266	1	Spring-Return, Hook
25	120-7951-03	1	Baffle-Cutoff	49	121-0739	1	Deflector-Discharge
27	1-603299	3	Roller-Scalp, Anti	50	138-7232	1	Spring-Torsion
28	138-7231	1	Pin-Chute	52	112-3977	3	Bolt-HH Shoulder 3/8-16 X 3.79
30	121-0751	3	Spindle ASM	53	131-8734	1	Link-Retention, Deck (RH)
30:2	120-7935	2	Spacer	54	131-4131	1	Link-Retention, Deck (LH)
30:3	136-5441	2	Bearing-Ball	56	126-7156	1	Decal-50 Series 2
31	32144-41	12	Screw-HWH 3/8-16 X 7/8 Taptite	57	32144-1	6	Screw-HWH #10-24 X 1/2 Taptite
				68	322-2	2	Screw-HH 5/16-18 X 5/8

50 Inch Deck and Decal Assembly

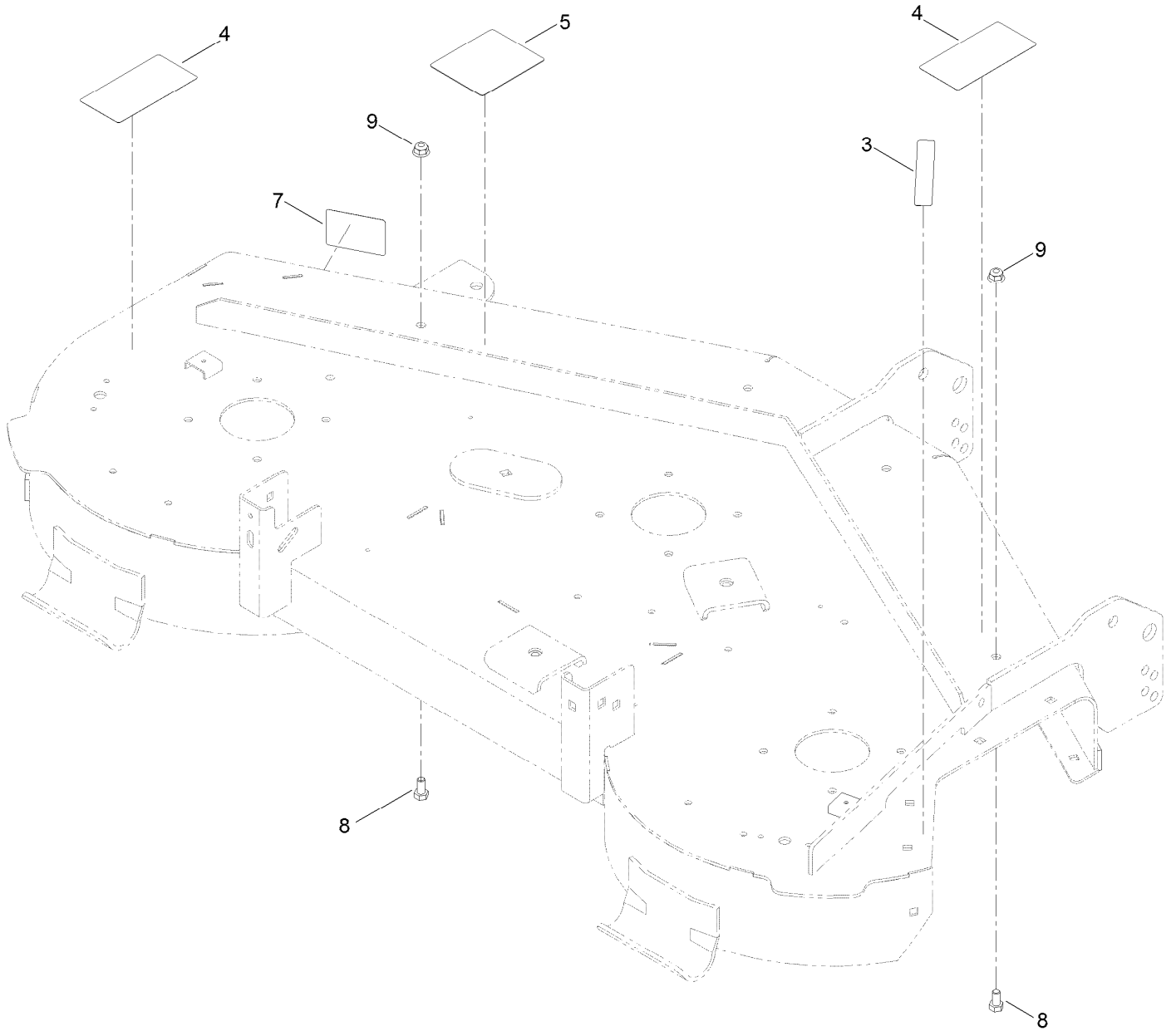

50 Inch Deck and Decal Assembly (continued)

<i>Ref.</i>	<i>Part Number</i>	<i>Qty.</i>	<i>Description</i>	<i>Ref.</i>	<i>Part Number</i>	<i>Qty.</i>	<i>Description</i>
3	93-7009	1	Decal-Danger	7	112-9840	1	Decal-Scalp, Anti
4	132-0872	2	Decal-Danger, Deck	8	322-2	2	Screw-HH
5	99-3943	1	Decal-Routing, Belt	9	104-8300	2	Nut-HF, NI

Main Frame Assembly

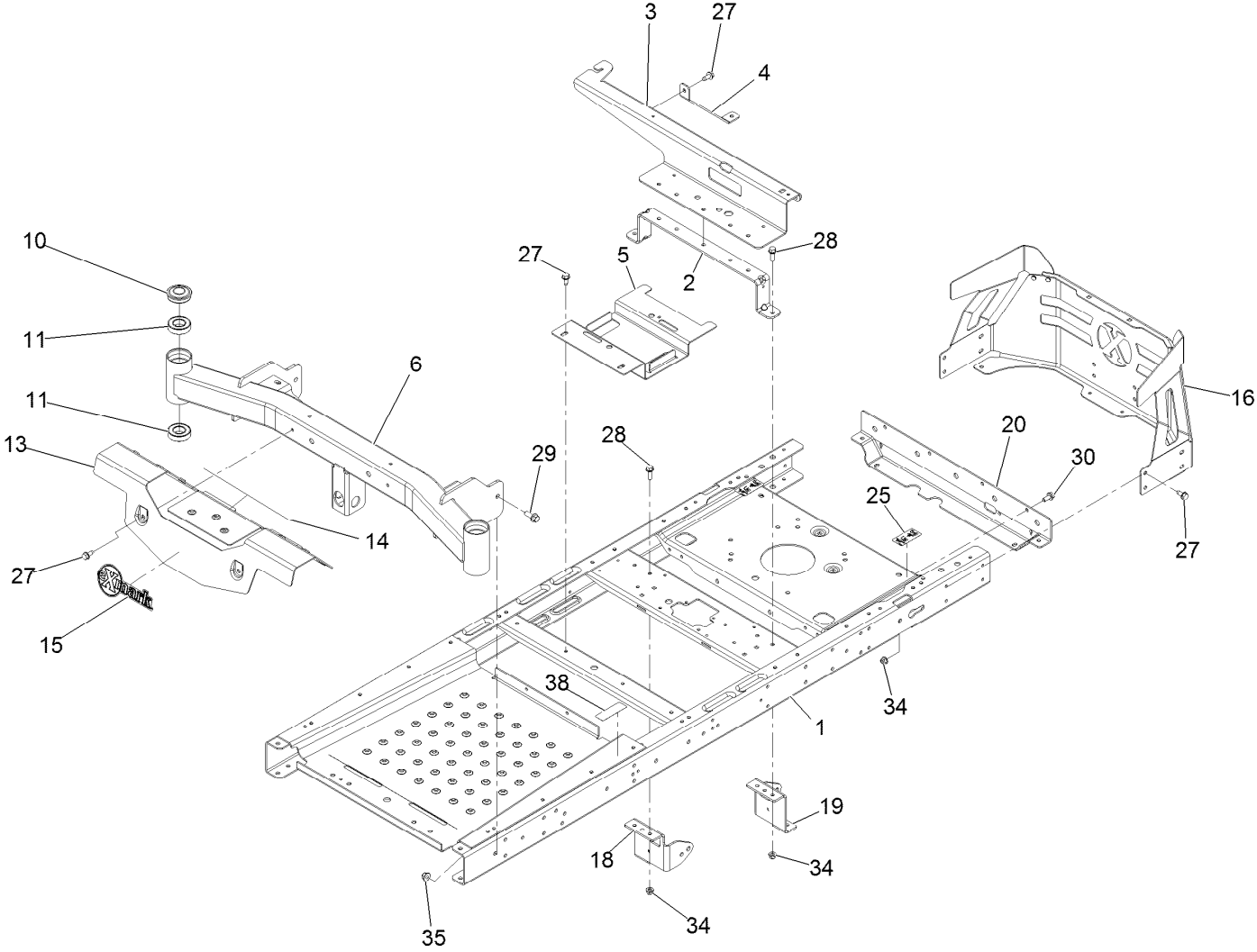

Main Frame Assembly (continued)

<i>Ref.</i>	<i>Part Number</i>	<i>Qty.</i>	<i>Description</i>	<i>Ref.</i>	<i>Part Number</i>	<i>Qty.</i>	<i>Description</i>
1	135-0508-01	1	Riveted Frame ASM (Wide Lever)	18	137-7020-01	1	Mount-Hydro, Front (Right)
2	135-0687-03	1	Brace-Seat, Rear (Wide)	19	139-3211-01	1	Mount-Hydro, Front (Left)
3	135-0867-03	1	Support-Pod [black]	20	130-6946-01	1	Crossmember-Rear, Wide
4	119-3431-03	1	Support-Tank, Rear	25	121-2989	2	Decal-Bypass
5	135-0507-03	1	Bracket-Battery	27	32144-70	16	Screw-HWH 5/16-18 X 3/4 Tf
6	135-2664-01	1	Axle-Front 50	28	3234-29	4	Screw-HH Flg 5/16-18 X 1
10	138-7200	2	Cap-Grease	29	3234-42	6	Screw HHF 3/8-16 X 1
11	109-3678	4	Bearing-Ball	30	3234-47	6	Screw-HH Flg 5/16-18 X 3/4
13	135-3363	1	Footrest ASM	34	104-8300	10	Nut-Nyloc 5/16-18 Flg
14	135-3295	1	Decal-Warning	35	104-8301	6	Nut-Nyloc 3/8-16 Flg
15	126-6598	1	Decal, Exmark Logo	38	115-9625	1	Decal-Brake, Parking
16	135-2821-03	1	Guard-Engine, ASM Wide [black]				

Main Frame Assembly W/Decals

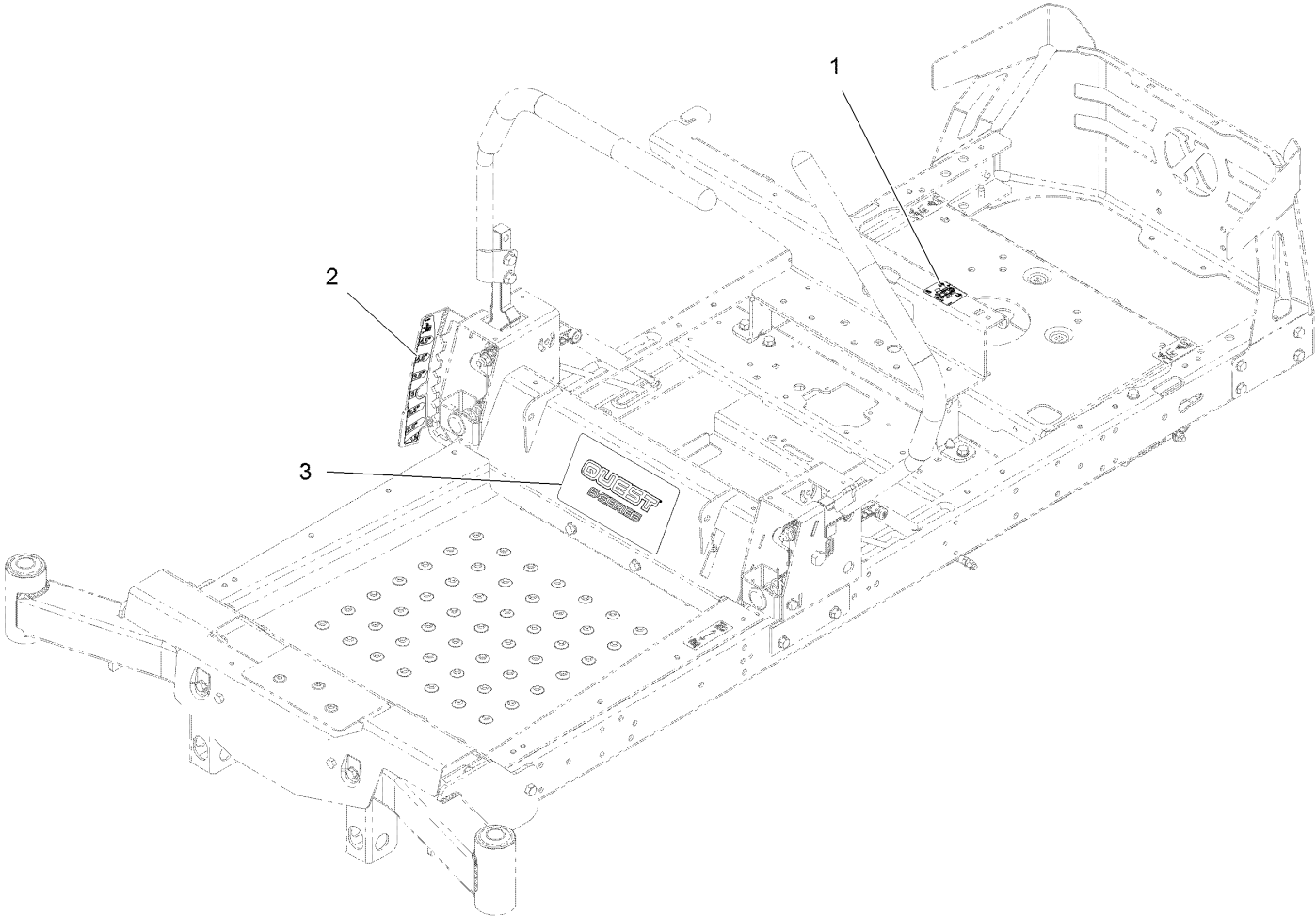

Main Frame Assembly W/Decals (continued)

<i>Ref.</i>	<i>Part Number</i>	<i>Qty.</i>	<i>Description</i>
1	106-8717	1	Decal-Service, CE
2	119-8870	1	Decal-HOC
3	135-3148	1	Decal, Quest S Series

Deck Lift Assembly

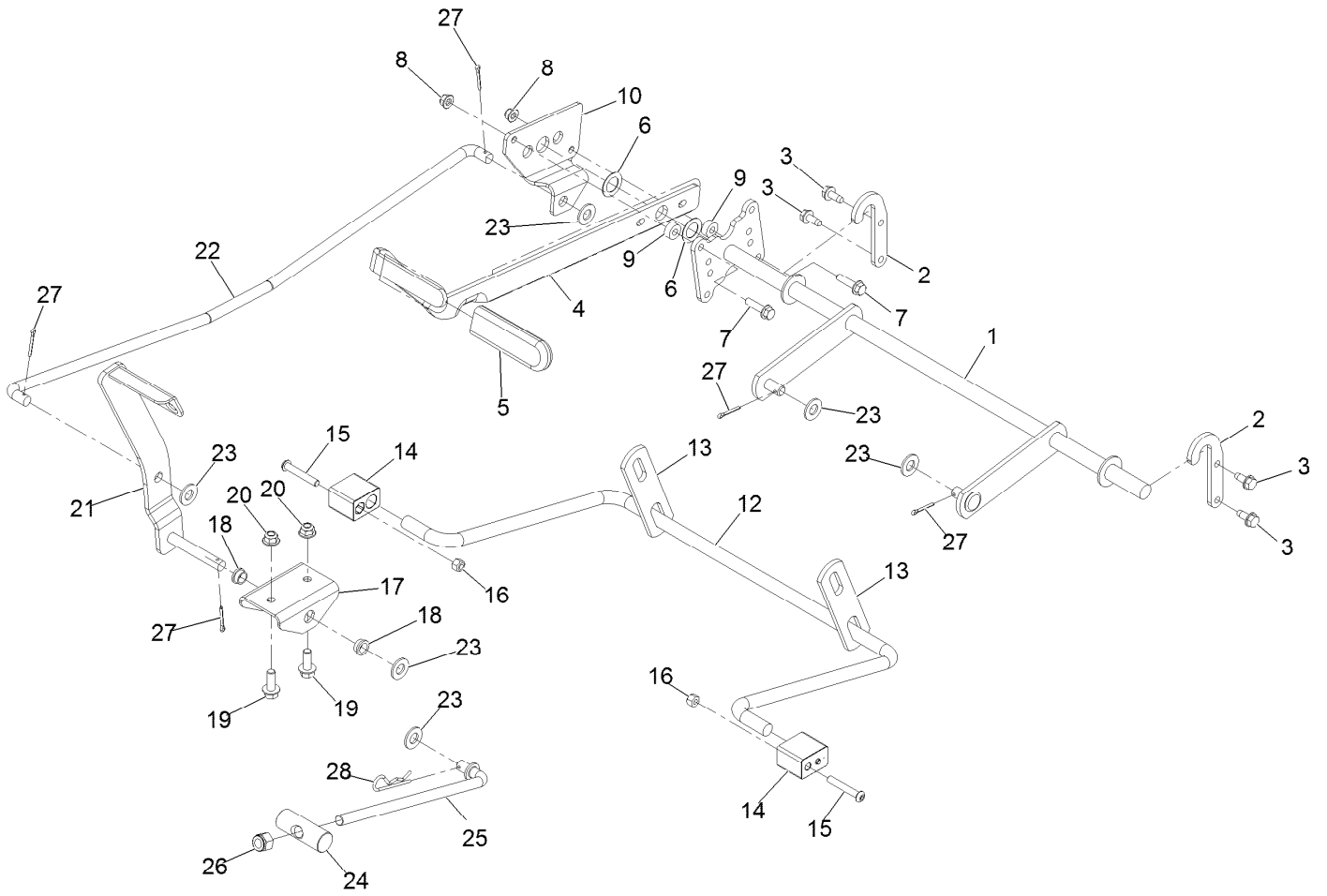

Deck Lift Assembly (continued)

<i>Ref.</i>	<i>Part Number</i>	<i>Qty.</i>	<i>Description</i>	<i>Ref.</i>	<i>Part Number</i>	<i>Qty.</i>	<i>Description</i>
1	132-6878-03	1	Lift-Deck (Wide)	15	120-5499	2	Screw-Button Head 5/16-18 X 2.00
2	138-7233	2	Bracket-Lift	16	3296-29	2	Nut-Nyloc 5/16-18
3	32144-70	4	Screw-HWH 5/16-18 X 3/4 Tf	17	120-2294-03	1	Bracket-Footlift
4	135-2284-03	1	Handle-Deck Lift	18	256-156	2	Bushing-Flange
5	1-633268	1	Grip-Lever	19	3234-42	2	Screw HHF 3/8-16 X 1
6	3-6498	2	Washer-Thrust	20	104-8301	2	Nut-Nyloc 3/8-16 Flg
7	3234-36	2	Screw-HH Flg 5/16-18 X 1 1/4	21	132-6939-03	1	Pedal ASM
8	104-8300	2	Nut-Nyloc 5/16-18 Flg	22	120-2242	1	Rod-Footlift
9	121-1759	2	Spacer	23	3256-26	6	Washer-1/2 SAE
10	131-3933	1	Plate-Footlift	24	119-8810	1	Pin-Pivot
12	138-7239	1	Arm-Lift, Rear (Wide)	25	133-4319	1	Rod-Mount, Deck
13	138-7235	2	Link-Lift	26	3296-19	1	Nut-Nyloc 1/2-20
14	108-7845	2	Block-Pivot	27	3272-11	5	Pin-Cotter 1/8 X 1
				28	1-806005	1	Hairpin-Cotter

Tire and Wheel Assembly

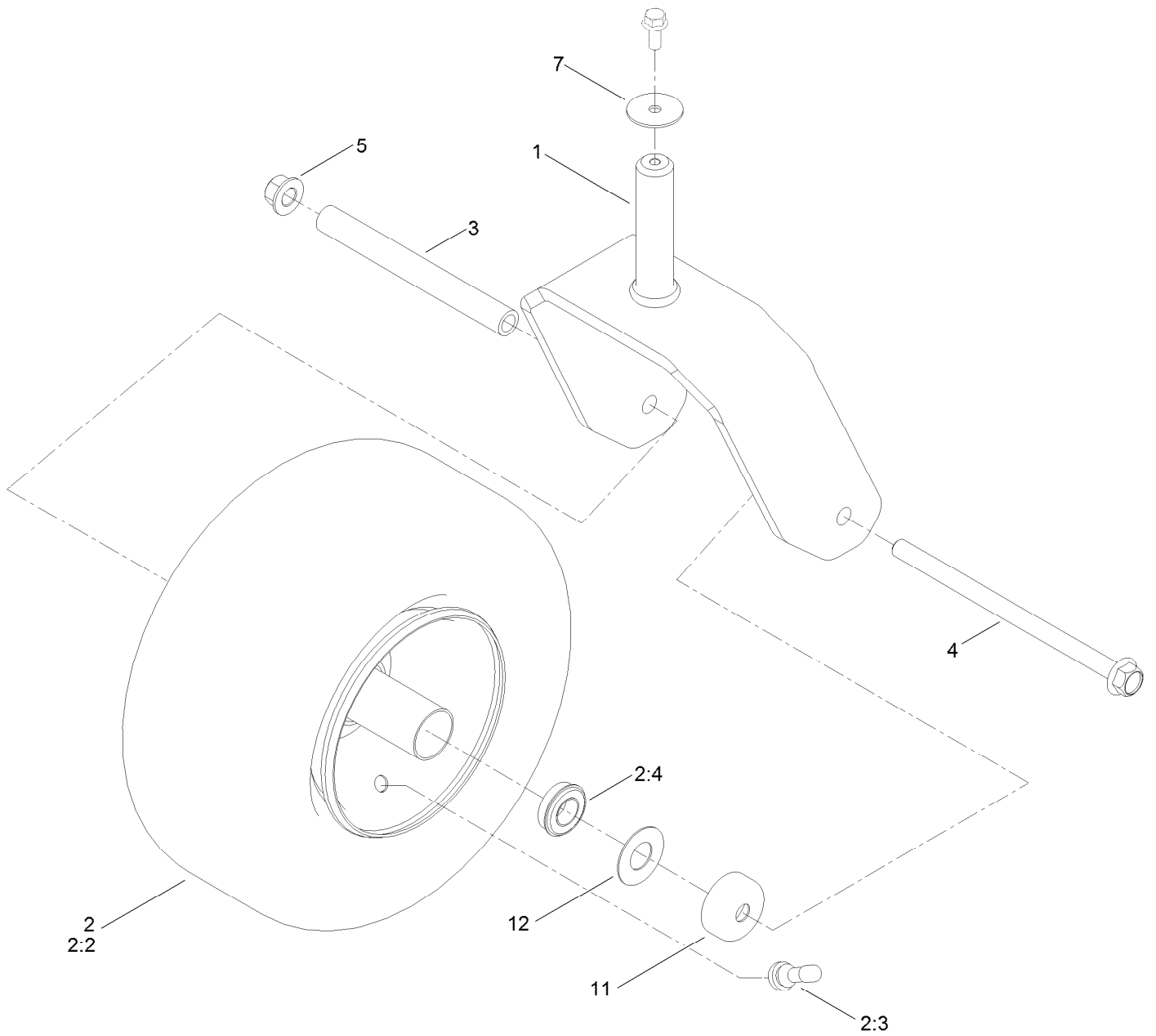

Tire and Wheel Assembly (continued)

<i>Ref.</i>	<i>Part Number</i>	<i>Qty.</i>	<i>Description</i>	<i>Ref.</i>	<i>Part Number</i>	<i>Qty.</i>	<i>Description</i>
1	133-4375-01	2	Fork ASM	3	133-4487	2	Spanner-Wheel
2	133-4427	2	Tire And Wheel ASM	4	126-5389	2	Screw-HHF
2:2	125-5581	1	Tire	5	99-5107	2	Nut-Lock
2:3	232-27	1	Stem-Valve	7	3256-68	2	Washer-Flat
2:4	136-4190	2	Bearing	11	133-7088	4	Guard-Seal
2:99	232-46	1	Tube-Inner ●	12	136-5590	4	Washer

● Not illustrated

Park Brake Assembly

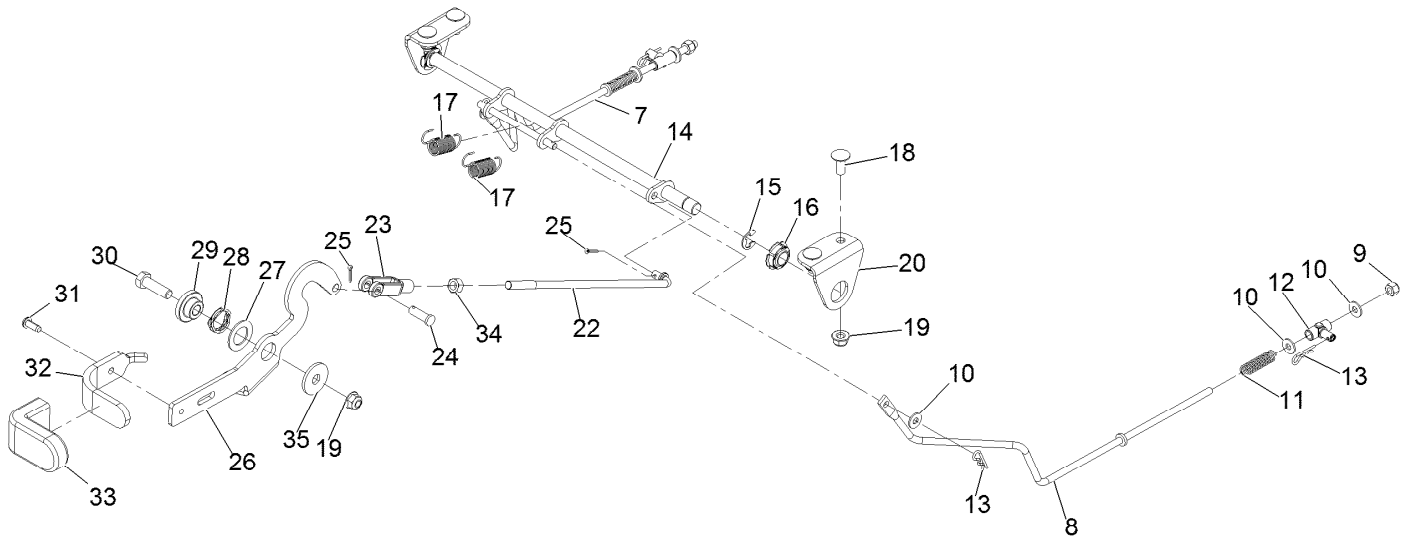

Park Brake Assembly (continued)

<i>Ref.</i>	<i>Part Number</i>	<i>Qty.</i>	<i>Description</i>	<i>Ref.</i>	<i>Part Number</i>	<i>Qty.</i>	<i>Description</i>
7	119-8811	1	Rod-Brake, RH	22	135-0164	1	Rod-Link Handle
8	119-8812	1	Rod-Brake, LH	23	1-303105	1	Yoke-Adjustable
9	3296-42	2	Nut-Nyloc 1/4-20	24	1-808280	1	Pin-Clevis 5/16 X 1 49/64
10	119-8952	6	Washer	25	3272-5	2	Pin-Cotter 3/32 X 1/2
11	121-5654	4	Spring-Compression	26	135-0165-03	1	Lever-Brake
12	119-8857	2	Mount-Pivot	27	119-7640	1	Washer-Thrust
13	3290-307	4	Pin-Cotter	28	121-4517	1	Washer-Wave
14	135-0148	1	Pivot-Brake	29	126-5989	1	Pivot-Flange
15	32120-47	2	Ring-Retaining	30	323-7	1	Screw-HH 3/8-16 X 1 1/4
16	136-7469	2	Bearing-Spherical	31	63-8590	1	Screw-Button Head 1/4-20 X .62 Tf
17	55-9280	2	Spring-Extension	32	135-0190-03	1	Handle-Brake
18	3230-23	4	Bolt-Carriage 5/16-18 X 3/4 Short Neck	33	132-4749	1	Grip-Lever
19	104-8300	5	Nut-Nyloc 5/16-18 Flg	34	3219-2	1	Nut-Hex 5/16-24
20	135-0147-03	2	Angle-Mount Pivot	35	2844	1	Washer

Rear Tire Assembly

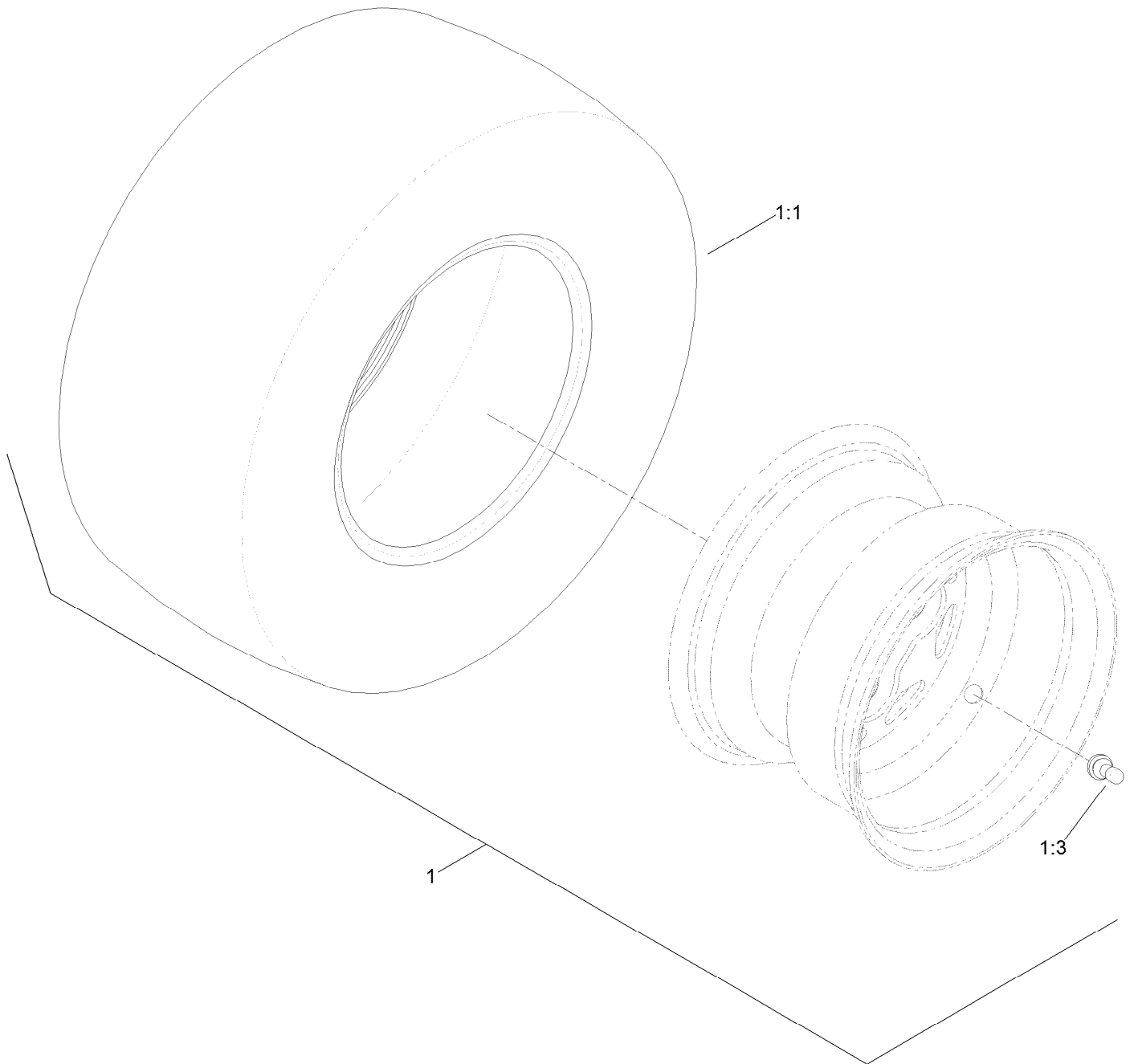

Rear Tire Assembly (continued)

<i>Ref.</i>	<i>Part Number</i>	<i>Qty.</i>	<i>Description</i>
1	133-9278	2	Tire And Wheel ASM
1:1	133-9293	1	Tire

<i>Ref.</i>	<i>Part Number</i>	<i>Qty.</i>	<i>Description</i>
1:3	232-27	1	Stem-Valve
1:99	105-4070	1	Tube-Inner ●

● Not illustrated

Seat Assembly

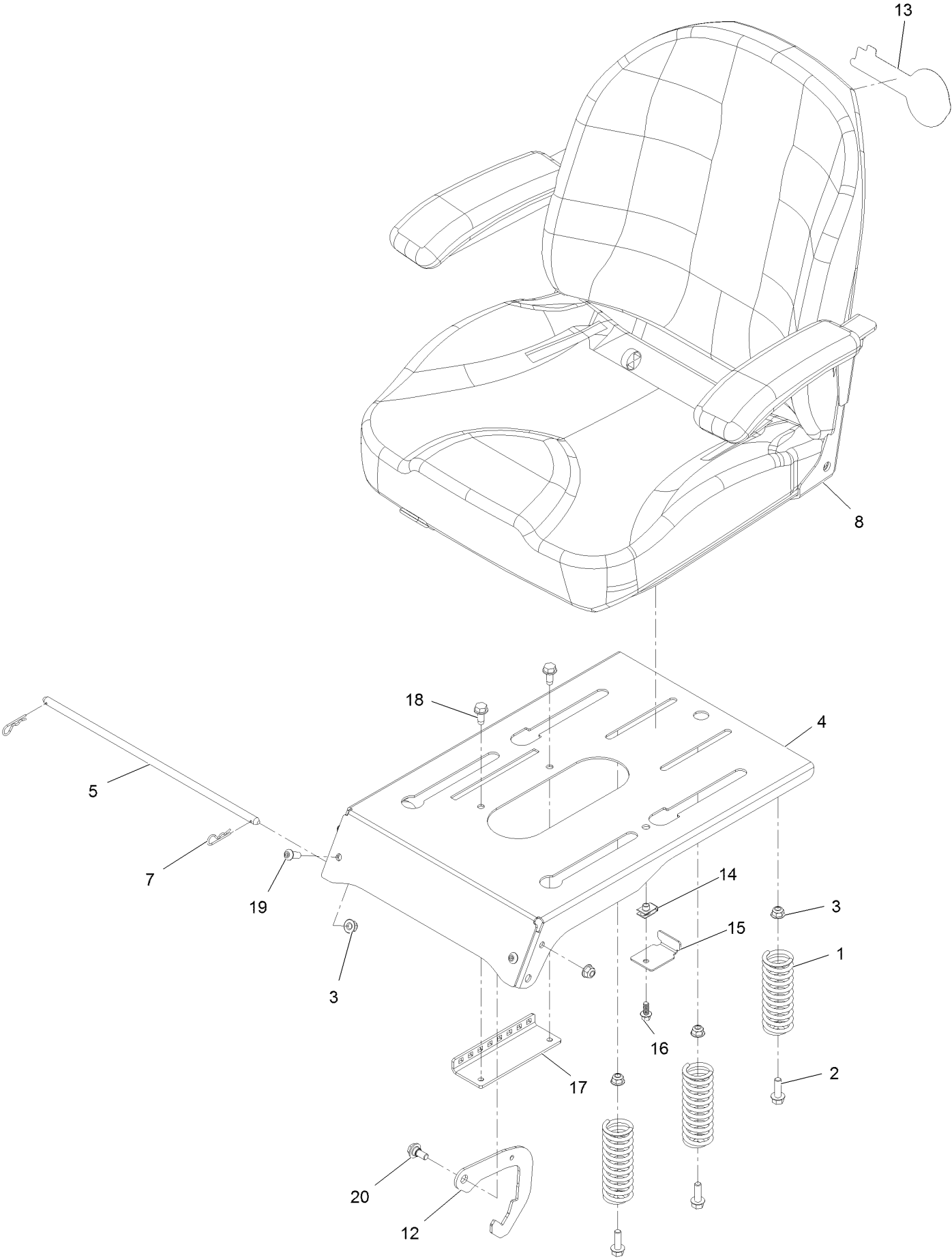

Seat Assembly (continued)

<i>Ref.</i>	<i>Part Number</i>	<i>Qty.</i>	<i>Description</i>	<i>Ref.</i>	<i>Part Number</i>	<i>Qty.</i>	<i>Description</i>
1	92-7054	3	Spring-Compression	14	107069	1	Nut-Retainer-Panel 1/4-20
2	3234-29	3	Screw-HH Flg 5/16-18 X 1	15	138-7214	1	Bracket-Stop, Seat
3	104-8300	7	Nut-Nyloc 5/16-18 Flg	16	99-6810	1	Screw-HH 1/4-20 X 5/8
4	136-5571-03	1	Pan-Seat, Deluxe	17	131-4008-03	1	Bracket-Latch, Seat
5	138-7213	1	Rod-Pivot, Narrow	18	32144-70	2	Screw-HWH 5/16-18 X 3/4 Tf
7	3290-250	2	Pin-Cotter	19	3274-55	2	Screw-Button Head 5/16-18 X 3/4
8	131-4148	1	Seat ASM, Exmark	20	19-1470	2	Screw-Shoulder
12	138-7250	2	Seat Latch				
13	135-3747	1	Decal, Exmark Logo				

Seat Assembly (cont)

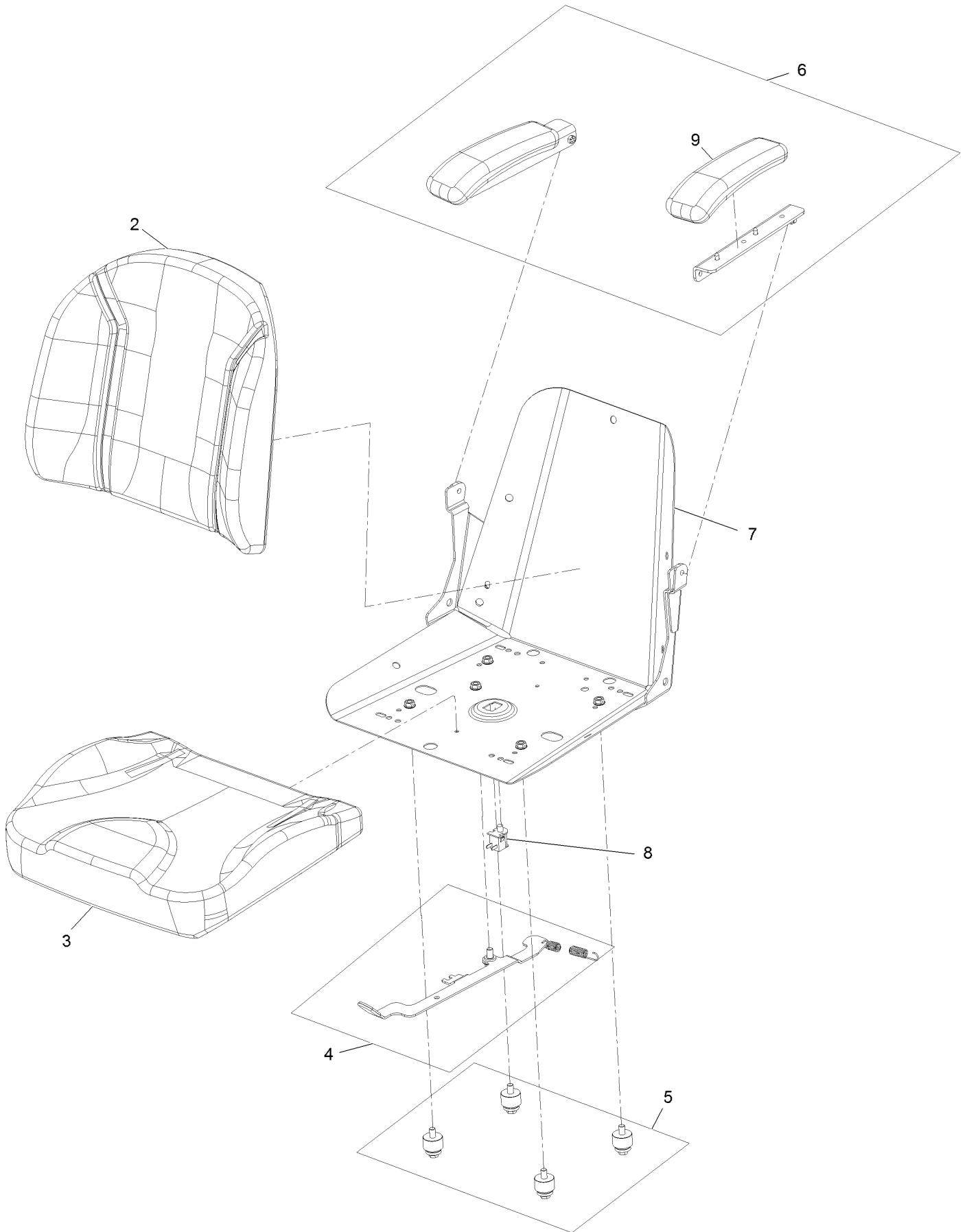

Seat Assembly (cont) (continued)

<i>Ref.</i>	<i>Part Number</i>	<i>Qty.</i>	<i>Description</i>	<i>Ref.</i>	<i>Part Number</i>	<i>Qty.</i>	<i>Description</i>
2	131-4150	1	Cushion-Seat, Back	6	131-4155	1	Armrest Kit
3	131-4152	1	Cushion-Seat, Bottom	7	131-4156	1	Shell
4	131-4153	1	Track ASM	8	82-2190	1	Switch-Bail
5	131-4154	1	Bushing ASM	9	110-4163	2	Cushion-Rest, Arm

Motion Control Assembly

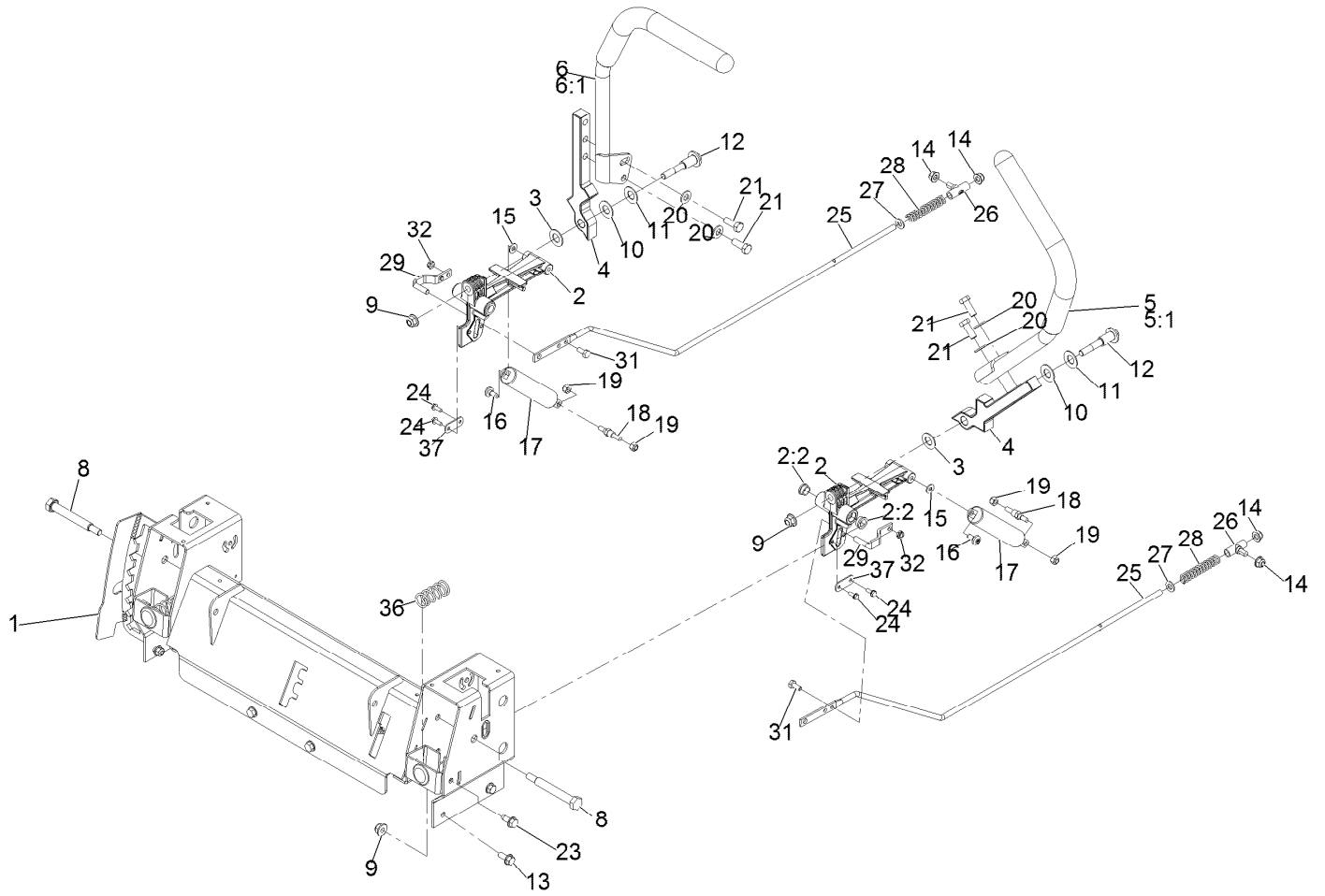

Motion Control Assembly (continued)

<i>Ref.</i>	<i>Part Number</i>	<i>Qty.</i>	<i>Description</i>	<i>Ref.</i>	<i>Part Number</i>	<i>Qty.</i>	<i>Description</i>
1	135-0183-03	1	Control-Box [black]	17	132-6853	2	Damper-Non Cavitating
2	119-3470	2	Actuator Arm ASM	18	110-6810	2	Stud-Damper
2:2	256-156	2	Bushing-Flange	19	3296-42	4	Nut-Nyloc 1/4-20
3	120-2273	2	Washer-Nylon	20	3256-24	4	Washer-3/8 SAE
4	133-9299-05	2	Arm-Control	21	323-6	4	Screw-HH 3/8-16 X 1
5	133-7055	1	Handle-Control, LH	23	32144-70	4	Screw-HWH 5/16-18 X 3/4 Tf
5:1	121-0726	1	Grip	24	32144-1	4	Screw-HWH #10-24 X 1/2 Taptite
6	133-7057	1	Handle-Control, RH	25	138-7217	2	Rod-Hydro
6:1	121-0726	1	Grip	26	138-7218	2	Mount-Rod, Hydro
8	115-5099	2	Bolt-Pivot	27	3256-23	2	Washer-5/16 SAE
9	104-8301	4	Nut-Nyloc 3/8-16 Flg	28	1-603807	2	Spring
10	117-1240	2	Washer	29	121-1753	2	Pin-Rod, Hydro
11	119-8925	2	Washer-Belleville	31	321-3	2	Screw-HH 1/4-20 X 5/8
12	139-2556	2	Bolt-Pivot	32	3296-56	2	Nut-Nyloc 1/4-20 Thin
13	3234-47	6	Screw-HH Flg 5/16-18 X 3/4	36	119-8876	2	Spring-Return
14	104-8300	10	Nut-Nyloc 5/16-18 Flg	37	119-8948	2	Plate-Stop, Hydro
15	119-8952	2	Washer				
16	120-7950	2	Screw-1/4-20 X 1/2 Tf Torx Plus				

Fuel Assembly

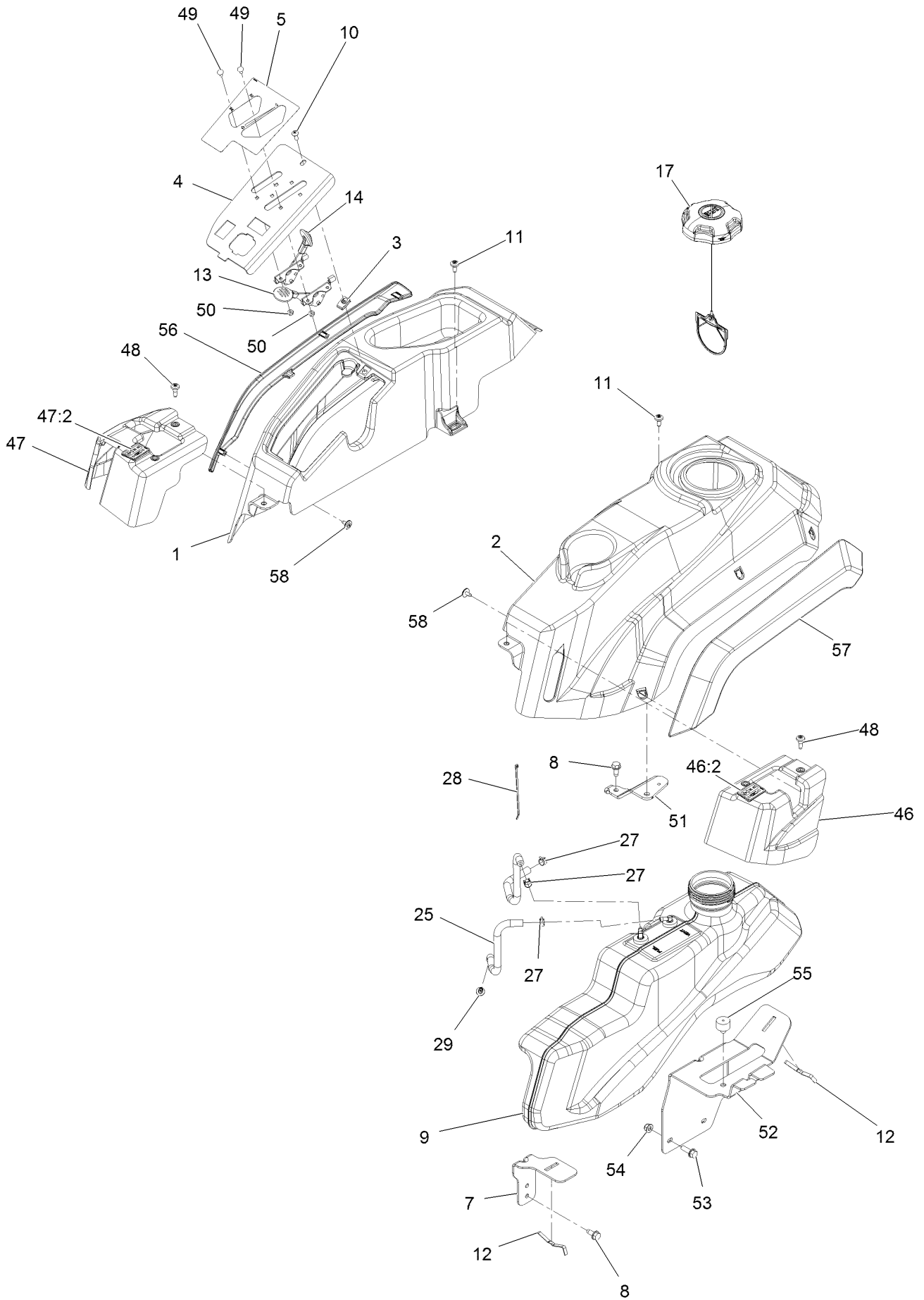

Fuel Assembly (continued)

<i>Ref.</i>	<i>Part Number</i>	<i>Qty.</i>	<i>Description</i>	<i>Ref.</i>	<i>Part Number</i>	<i>Qty.</i>	<i>Description</i>
1	135-1392	1	Pod-RH, Narrow	28	614249	1	Tie-Cable
2	135-1138	1	Pod-LH, Narrow	29	117-5399	1	Adaptor-Orifice
3	107069	1	Nut-Retainer-Panel 1/4-20	46	135-3162	1	ASM, Pod Mc W/Decal LH
4	135-1402-03	1	Panel-Control, Narrow	46:2	135-2310	1	Decal-Motion Control
5	135-2470	1	Decal-Control	47	135-3163	1	ASM, Pod Mc W/Decal RH
7	135-1564-03	1	Support-Tank [black]	47:2	135-2310	1	Decal-Motion Control
8	32144-70	4	Screw-HWH 5/16-18 X 3/4 Tf	48	135-2015	2	Screw-Shoulder
9	135-4520	1	Tank, Fuel	49	1-807513	4	Bolt-Carriage #10-24 X 1/2
10	3258-166	1	Screw-PPH 1/4-20 X 3/4	50	3296-2	4	Nut-Nyloc #10-24
11	120-7950	5	Screw-1/4-20 X 1/2 Tf Torx Plus	51	135-0868-03	1	Bracket-Clamp
12	609830	4	Spring	52	135-1563-03	1	Bracket-Support Tank
13	126-6944	1	Cable-Control, Throttle	53	3234-29	2	Screw-HH Flg 5/16-18 X 1
14	126-6945	1	Cable-Control, Choke	54	104-8300	2	Nut-Nyloc 5/16-18 Flg
17	137-4119	1	Cap-Fuel, Ratcheting	55	120-7893	2	Bumper-Grommet
25	109-0294	1	Hose-Fuel Line 10 1/2"	56	126-4741	1	Fender-RH
25	109-0297	1	Hose-Fuel	57	126-4742	1	Fender-LH
27	2412-98	3	Clamp-Hose	58	126-5544	6	Screw-HWH #10-14 X 1/2 Torx

Engine Assembly

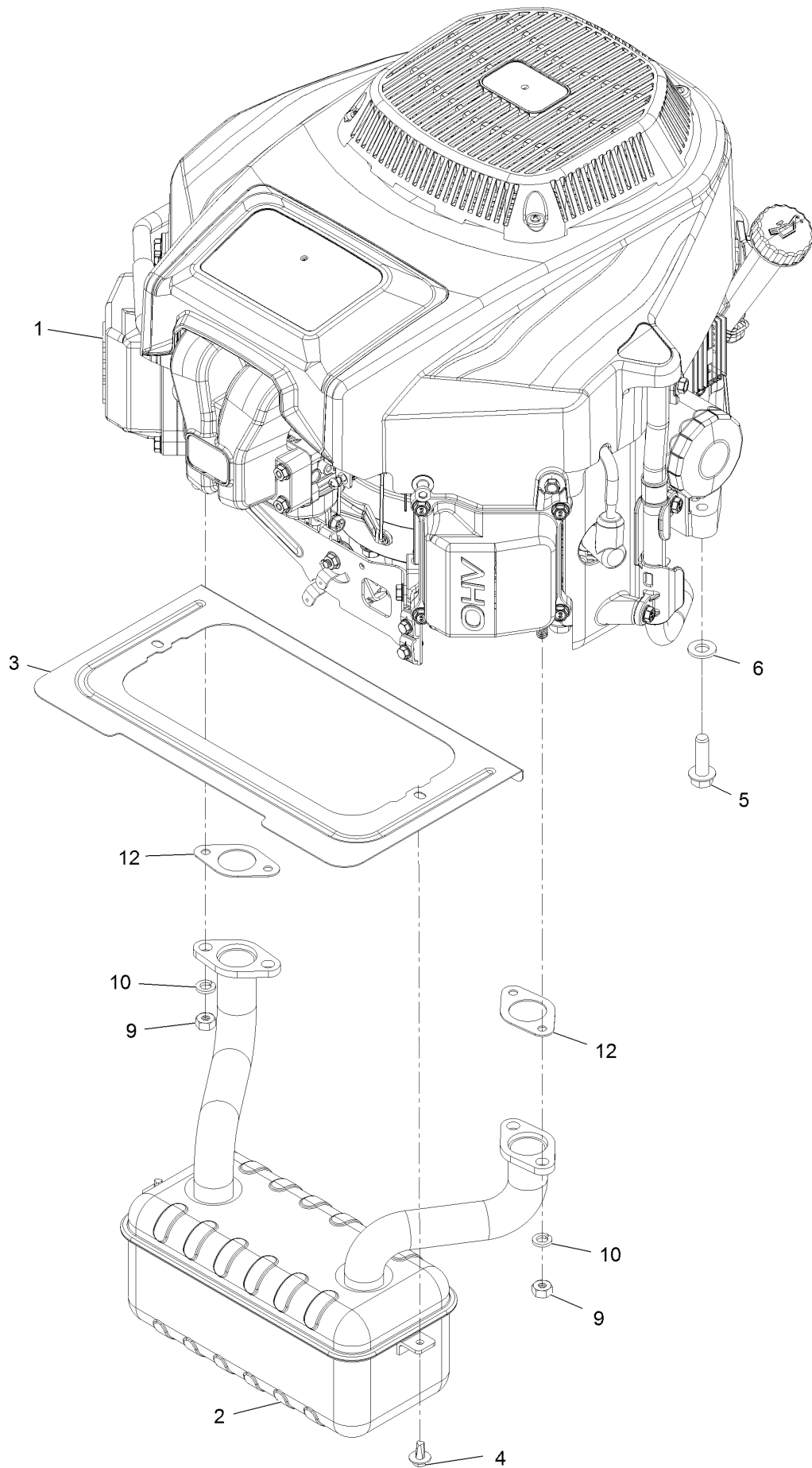

Engine Assembly (continued)

<i>Ref.</i>	<i>Part Number</i>	<i>Qty.</i>	<i>Description</i>	<i>Ref.</i>	<i>Part Number</i>	<i>Qty.</i>	<i>Description</i>
1	139-0603	1	Engine-2P77F	6	3256-24	3	Washer-3/8 SAE
2	130-6851	1	Muffler	9	121-0199	4	Nut-Hex M8
3	131-1071-03	1	Shield-Heat	10	127-9279	4	Washer-Lock, Split
4	46-8560	2	Screw-HHF 1/4-20 X 1/2	12	120-4317	2	Gasket-Exhaust
5	32144-109	4	Screw-HWH 3/8-16 X 1 1/4 Taptite				

Engine W/Decal Assembly

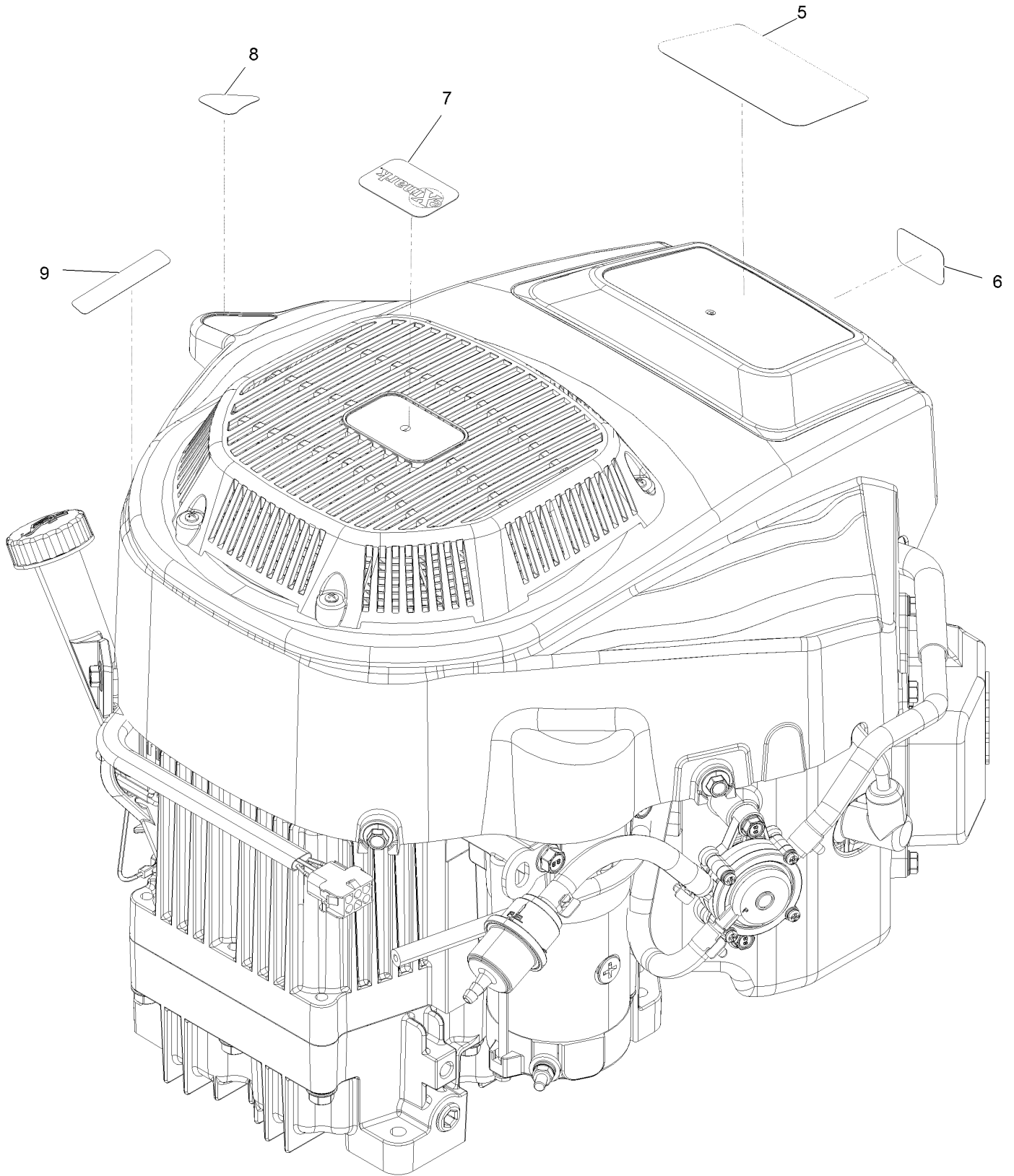

Engine W/Decal Assembly (continued)

<i>Ref.</i>	<i>Part Number</i>	<i>Qty.</i>	<i>Description</i>	<i>Ref.</i>	<i>Part Number</i>	<i>Qty.</i>	<i>Description</i>
5	142-2632	1	Decal-Engine 708 V-Twin Exmark	7	131-1078	1	Decal
6	127-9077	1	Placard-Intake, Exmark	8	131-1097	1	Decal-Drain, Oil
				9	132-0904	1	Decal-Shutdown

Clutch Assembly

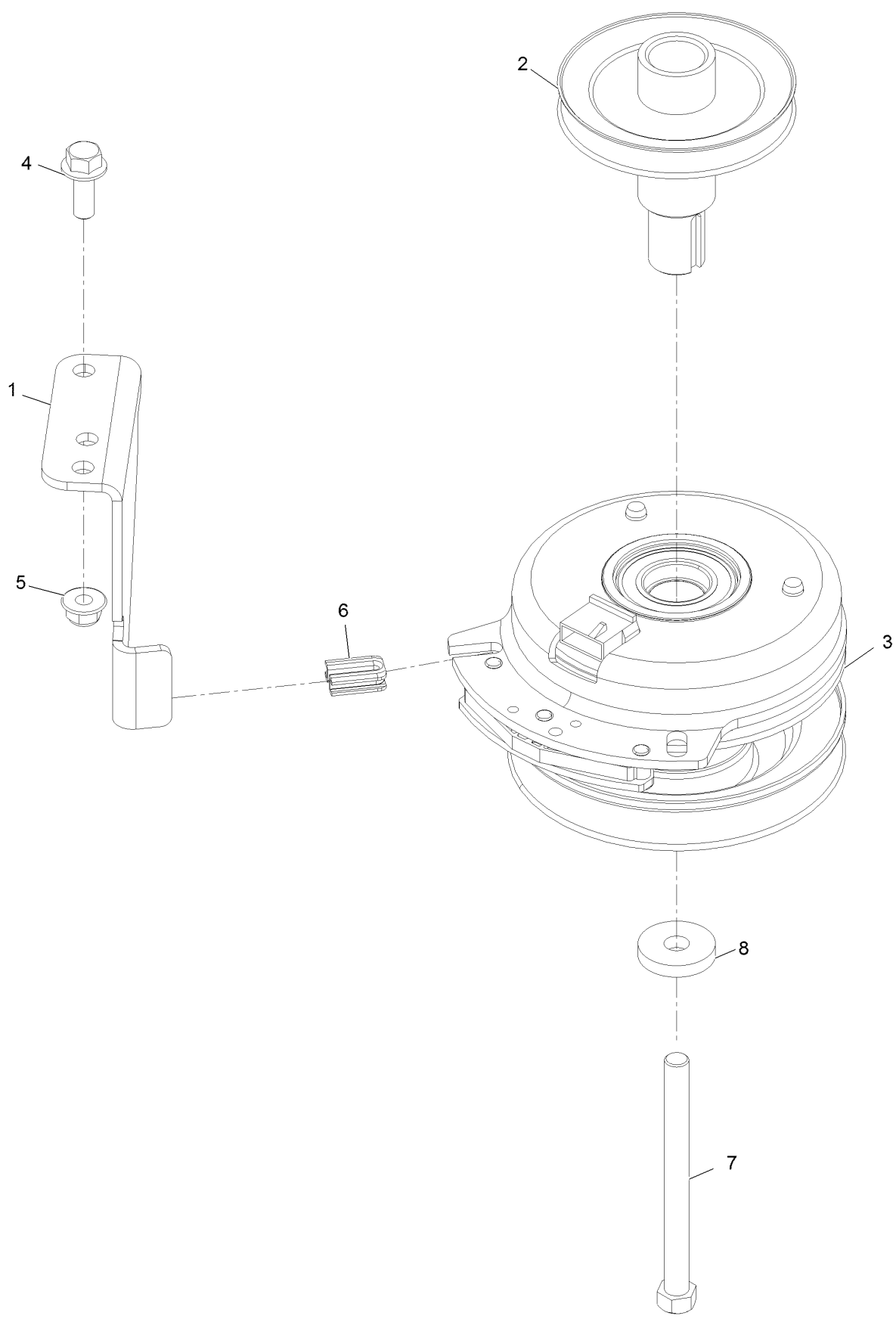

Clutch Assembly (continued)

<i>Ref.</i>	<i>Part Number</i>	<i>Qty.</i>	<i>Description</i>	<i>Ref.</i>	<i>Part Number</i>	<i>Qty.</i>	<i>Description</i>
1	137-7000	1	Stop-Clutch (Wide)	5	104-8301	1	Nut-HF, NI
2	138-9792	1	Pulley-Engine	6	120-2217	1	Isolator-Clutch
3	127-3410	1	Clutch-PTO	7	3212-19	1	Screw-HH
4	3234-42	1	Screw-HHF	8	112843	1	Washer

Fuel System Assembly with Non-Canister Style Air Filter

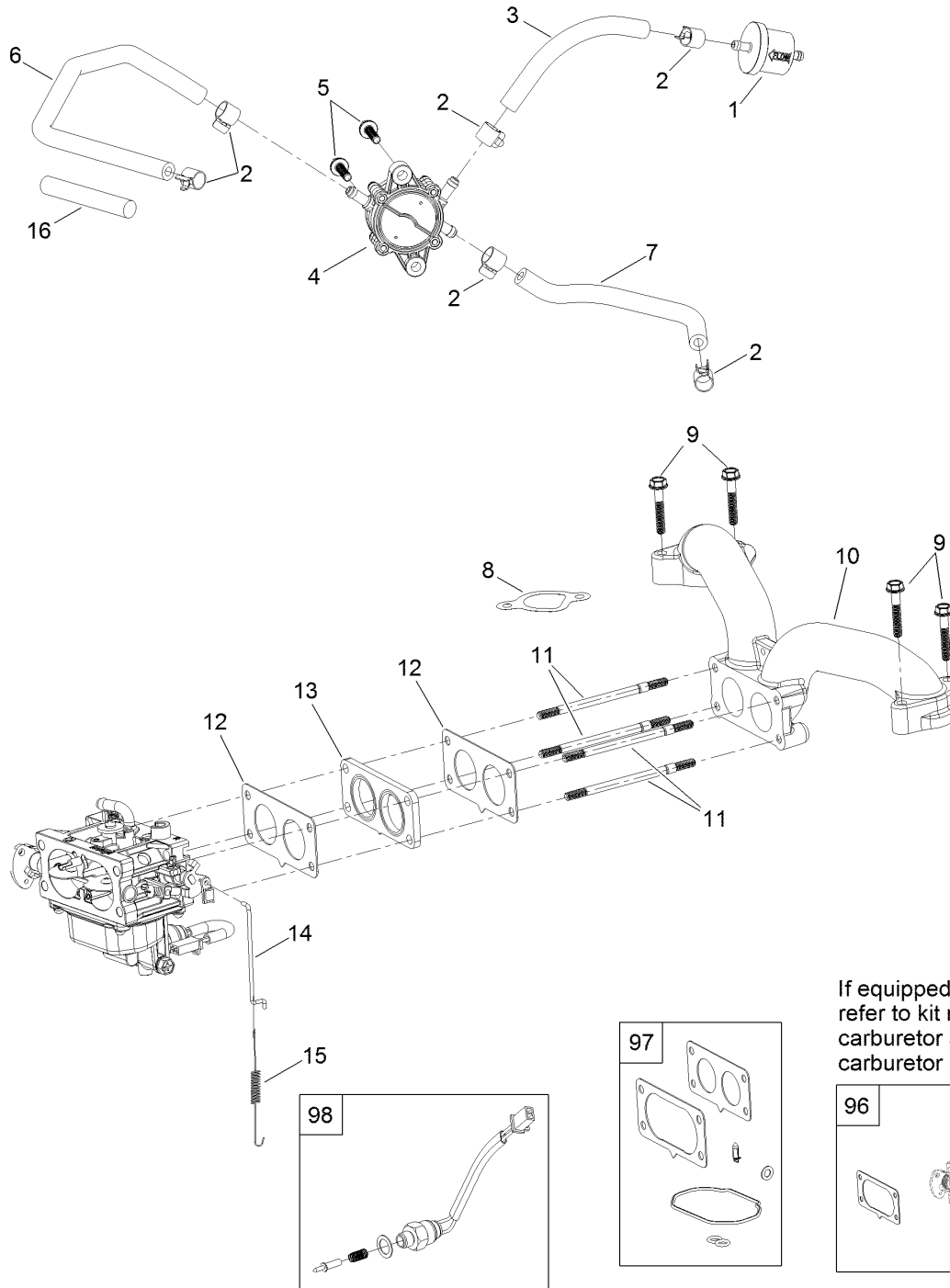

Fuel System Assembly with Non-Canister Style Air Filter (continued)

<i>Ref.</i>	<i>Part Number</i>	<i>Qty.</i>	<i>Description</i>	<i>Ref.</i>	<i>Part Number</i>	<i>Qty.</i>	<i>Description</i>
1	133-1563	1	Filter-Fuel	11	127-9245	4	Stud
2	120-4251	6	Clamp-Fuel Line	12	127-9246	2	Gasket-Carburetor
3	120-4371	1	Line-Fuel	13	127-9247	1	Insulator-Carburetor
4	127-9206	1	Pump-Fuel	14	133-9963	1	Linkage-Throttle
5	120-4225	2	Screw-HHF	15	133-9964	1	Spring-Return, Throttle
6	127-9205	1	Hose-Fuel	16	127-9355	1	Sleeve-Fuel Line Protector
7	127-9207	1	Hose-Fuel	96	136-7840	1	Carburetor Replacement Kit
8	127-9230	2	Gasket-Intake	97	127-9290	1	Carburetor Repair Kit
9	120-4284	4	Screw-HHF	98	127-9292	1	Solenoid Kit
10	127-9244	1	Manifold-Intake	99	136-7837	1	High Altitude Kit ●

● Not illustrated

Carburetor Assembly

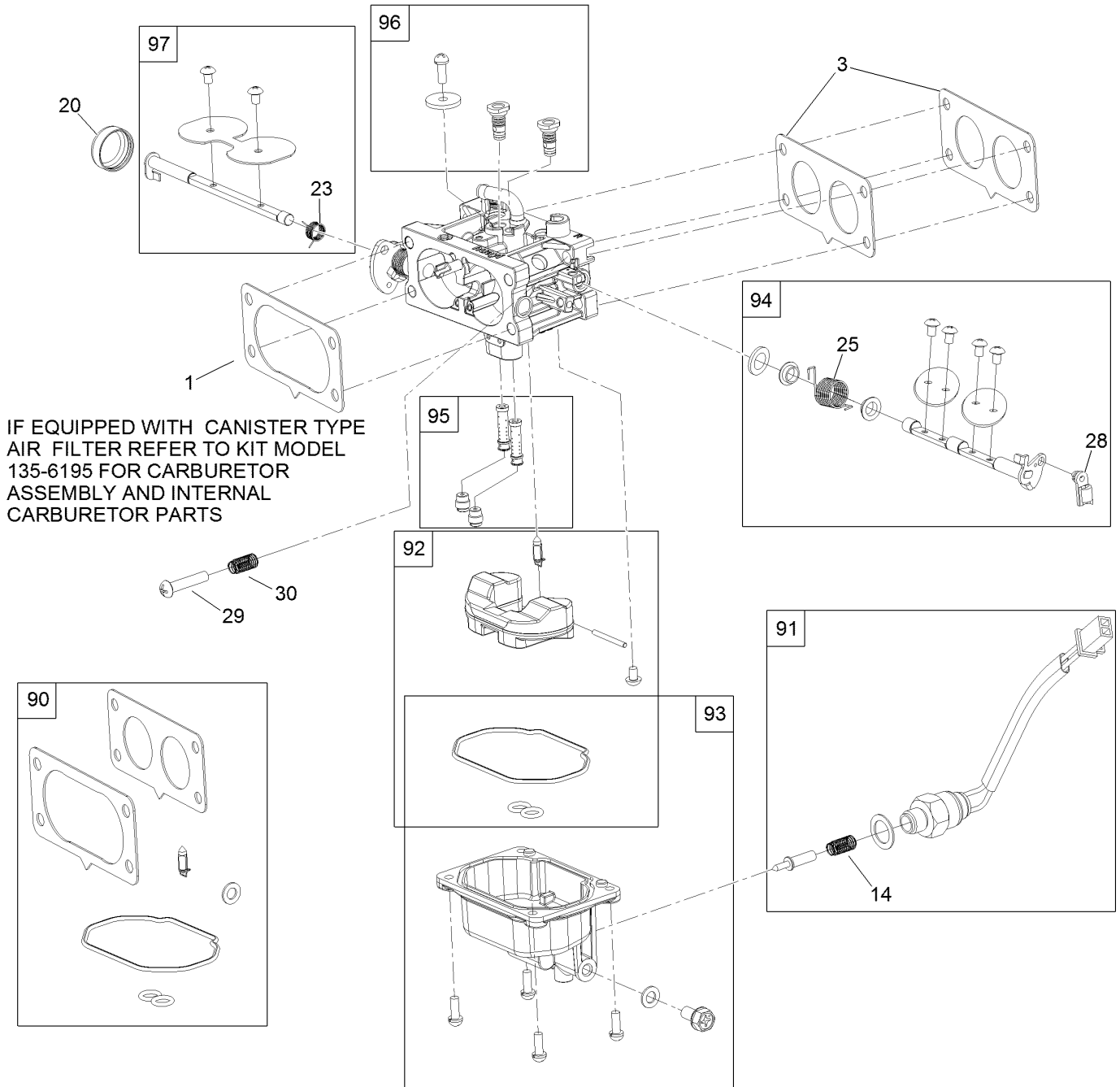

Carburetor Assembly (continued)

<i>Ref.</i>	<i>Part Number</i>	<i>Qty.</i>	<i>Description</i>	<i>Ref.</i>	<i>Part Number</i>	<i>Qty.</i>	<i>Description</i>
1	127-9251	1	Gasket-Carburetor	90	127-9290	1	Carburetor Repair Kit
3	127-9246	2	Gasket-Carburetor	91	127-9292	1	Solenoid Kit
14	127-9319	1	Spring	92	127-9340	1	Float Kit
20	127-9325	1	Cover-Shaft, Choke	93	127-9341	1	Bowl Kit
23	127-9328	1	Spring	94	133-9817	1	Throttle Shaft Kit
25	127-9330	1	Spring	95	136-7844	1	Nozzle And Jet Kit
28	127-9333	1	Clamp-Lock	96	136-7899	1	Idle Jet Kit
29	127-9334	1	Screw-PPH	97	127-9345	1	Choke Shaft Kit
30	127-9335	1	Spring				

Air Intake and Filtration Assembly

IF EQUIPPED WITH CANISTER TYPE AIR FILTER
REFER TO KIT MODEL 135-6195 TO LOOK UP PARTS

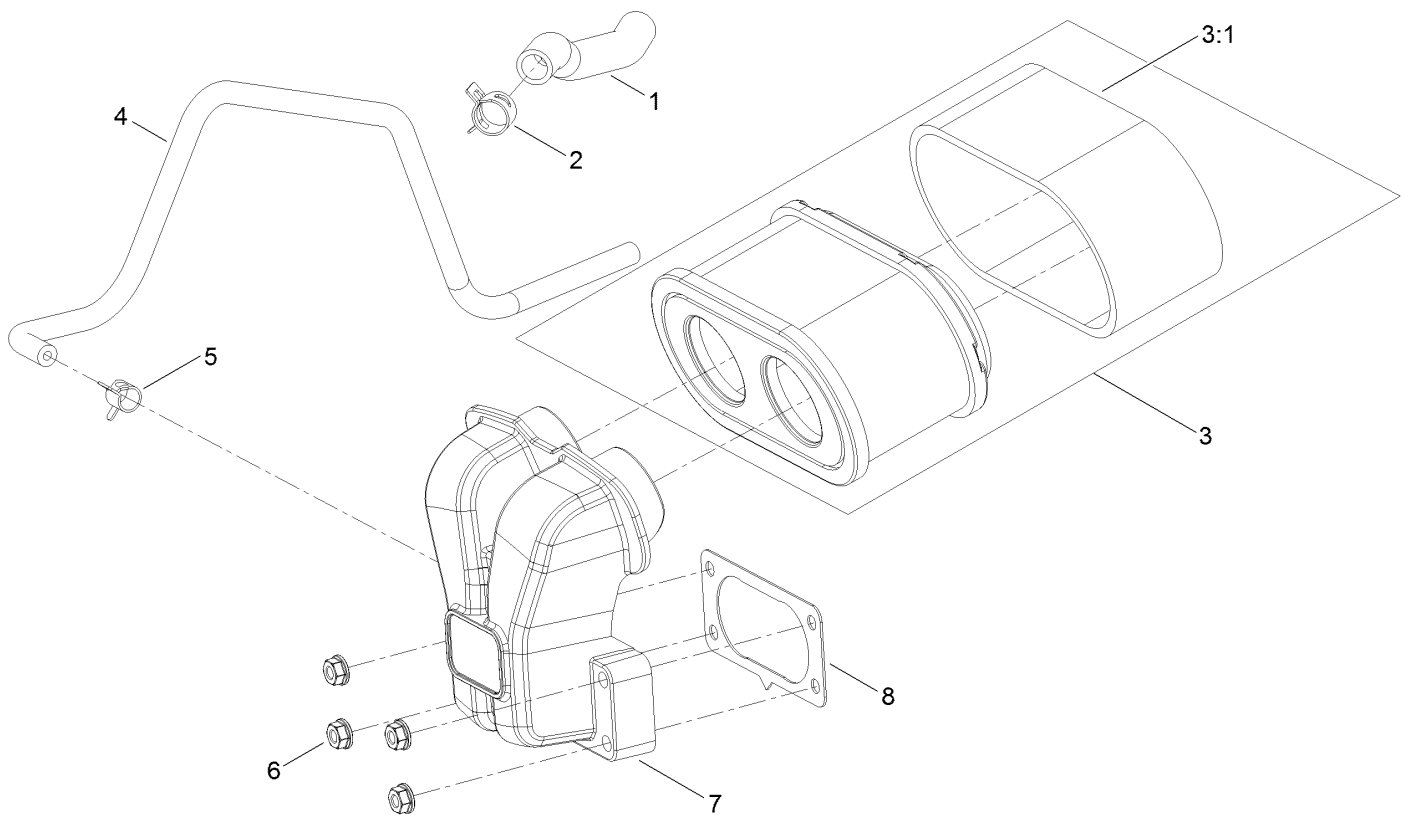

Air Intake and Filtration Assembly (continued)

<i>Ref.</i>	<i>Part Number</i>	<i>Qty.</i>	<i>Description</i>	<i>Ref.</i>	<i>Part Number</i>	<i>Qty.</i>	<i>Description</i>
1	127-9235	1	Tube-Breather	5	127-9187	1	Clamp-Hose
2	127-9234	2	Clamp-Hose	6	120-4236	4	Nut-Flange
3	136-7806	1	Air Filter Kit	7	127-9047	1	Manifold-Filter, Air
3:1	136-7804	1	Prefilter	8	127-9251	1	Gasket-Carburetor
4	127-9253	1	Hose-Fuel				

Ignition and Cooling Fan

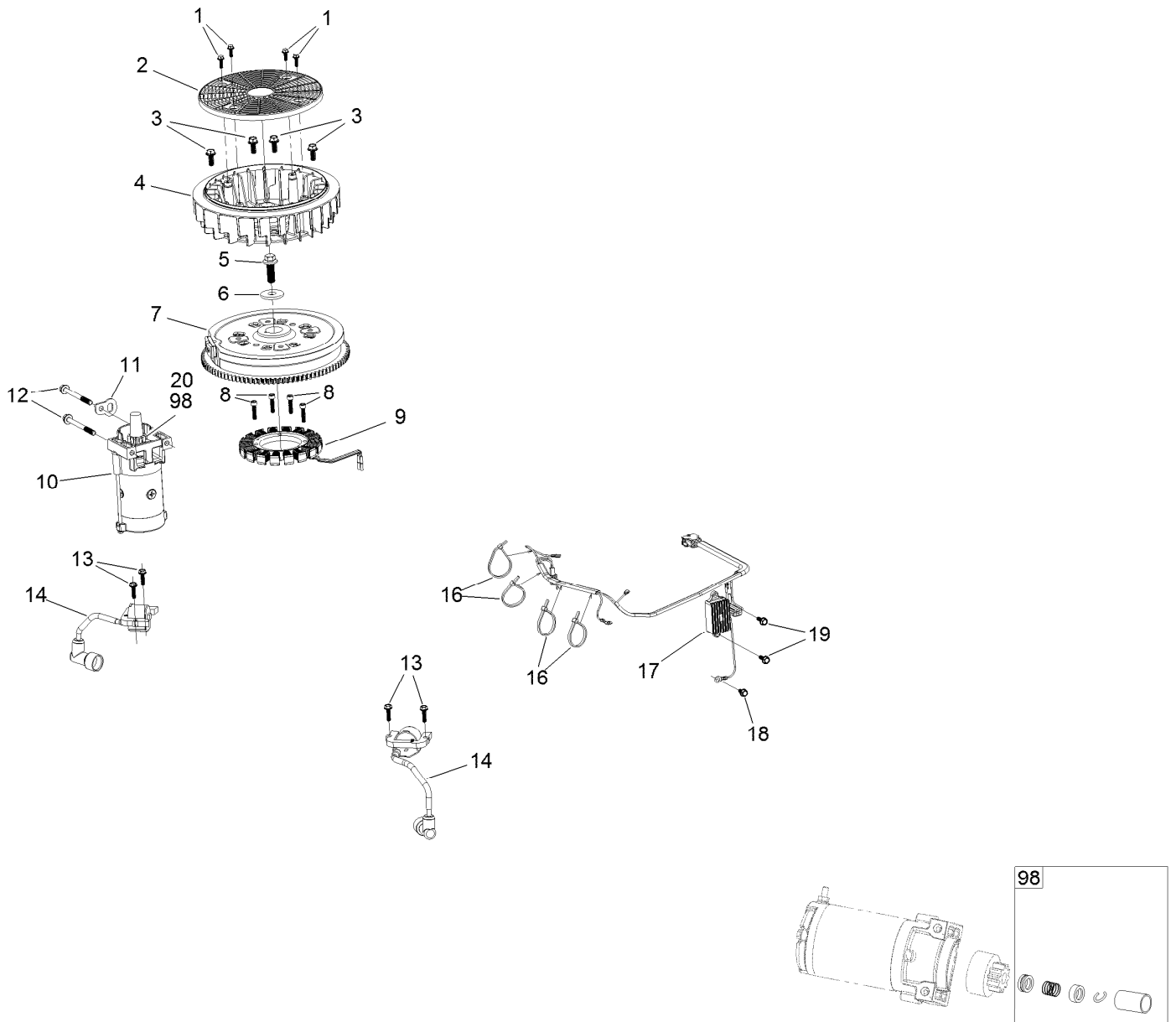

Ignition and Cooling Fan (continued)

<i>Ref.</i>	<i>Part Number</i>	<i>Qty.</i>	<i>Description</i>	<i>Ref.</i>	<i>Part Number</i>	<i>Qty.</i>	<i>Description</i>
1	127-9197	4	Screw-HWH	12	120-4231	2	Screw-HHF
2	127-9198	1	Screen-Rotating	13	121-0007	4	Bolt-Flange
3	127-9199	4	Screw-HWH	14	136-7883	2	Ignition Coil ASM
4	127-9200	1	Fan-Cooling	16	127-9220	4	Tie-Zip
5	127-9201	1	Screw-HWH	17	136-7879	1	Regulator-Voltage, W/Harness
6	127-9202	1	Washer-Spring	18	120-4216	1	Screw-HHF
7	127-9306	1	Flywheel	19	120-4232	2	Screw-HHF
8	127-9210	4	Screw-HSH	20	133-1562	1	Pinion-Starter
9	136-7876	1	Alternator	98	133-1566	1	Starter Repair Kit
10	136-7880	1	Motor-Starter				
11	127-9208	1	Bracket-Lift				

Crankcase and Crankshaft Assembly

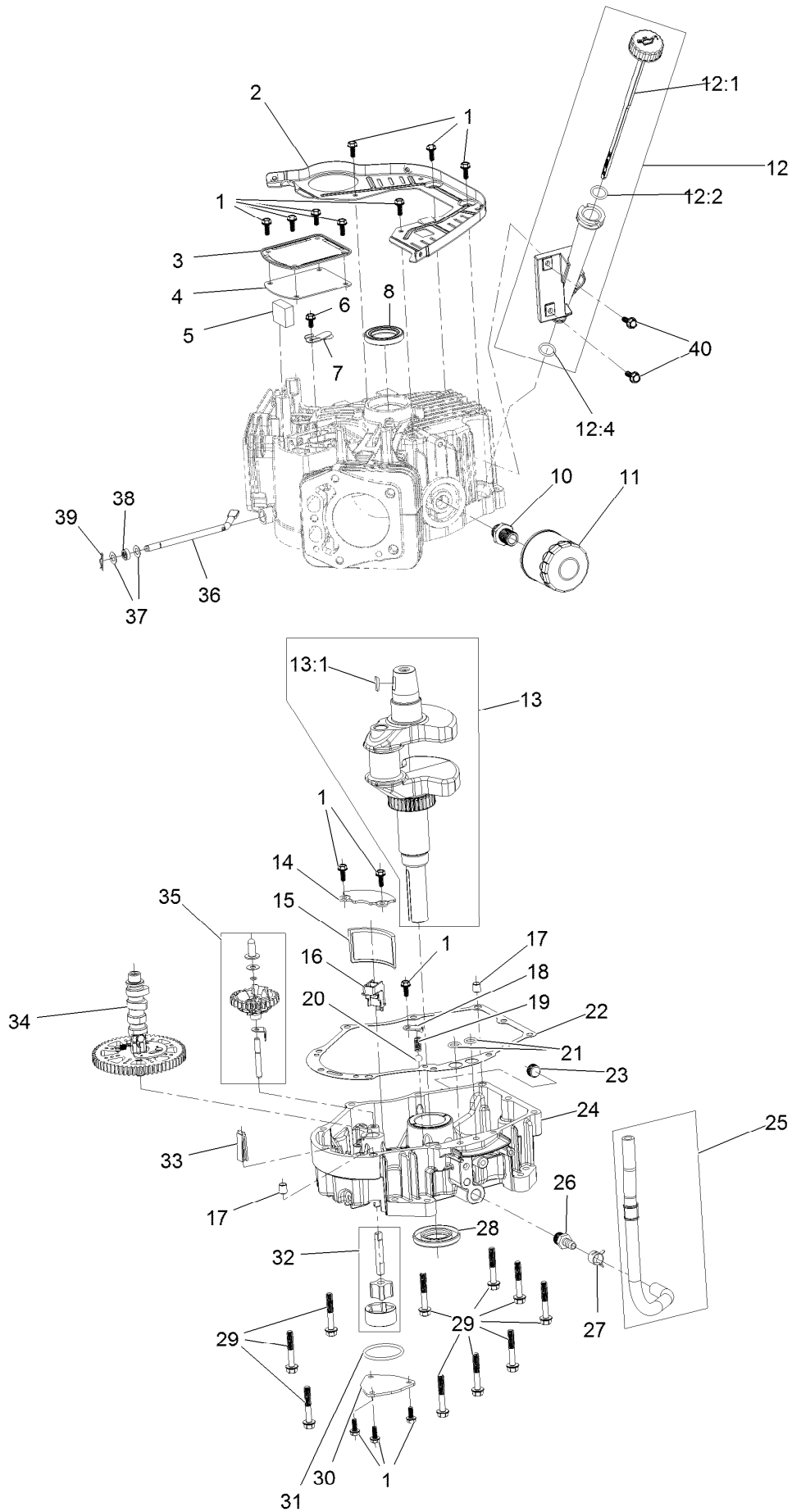

Crankcase and Crankshaft Assembly (continued)

<i>Ref.</i>	<i>Part Number</i>	<i>Qty.</i>	<i>Description</i>	<i>Ref.</i>	<i>Part Number</i>	<i>Qty.</i>	<i>Description</i>
1	120-4232	14	Screw-HHF	20	127-9266	1	Valve-Ball
2	127-9212	1	Baffle	21	120-4262	2	O-Ring
3	127-9213	1	Cover-Breather	22	127-9267	1	Gasket-Cover, Crankcase
4	127-9214	1	Gasket-Breather	23	133-9805	1	Plug-Drain
5	127-9215	1	Filter-Breather	24	133-9806	1	Cover-Crankcase
6	120-4216	1	Screw-HHF	25	127-9293	1	Oil Drain Hose ASM
7	127-9217	1	Valve-Breather	26	127-9275	1	Fitting-Hose
8	120-4267	1	Seal-Oil	27	127-9276	1	Clamp-Hose
10	136-7884	1	Adaptor-Filter, Oil	28	127-9271	1	Seal
11	136-7848	1	Filter-Oil	29	121-0473	10	Screw-HHF
12	127-9218	1	Oil Tube ASM	30	127-9274	1	Cover-Oil Pump
12:1	127-9283	1	Dipstick	31	127-9273	1	O-Ring
12:2	127-9284	1	O-Ring	32	127-9272	1	Oil Pump ASM
12:4	127-9286	1	O-Ring	33	120-4275	1	Deflector-Oil, Rubber
13	127-9255	1	Crankshaft	34	133-1568	1	Camshaft
13:1	120-4320	1	Key-Woodruff	35	136-7882	1	Governor ASM
14	127-9261	1	Cover-Screen, Oil	36	127-9238	1	Shaft-Governor
15	127-9262	1	Screen-Oil	37	120-4258	2	Washer-Plain
16	127-9263	1	Retainer-Screen	38	120-4257	1	Seal-Oil
17	120-4274	2	Pin-Dowel	39	120-4256	1	Pin-Hair
18	127-9264	1	Plate-Retainer	40	120-4232	2	Screw-HHF
19	127-9265	1	Spring				

Governor Control Assembly

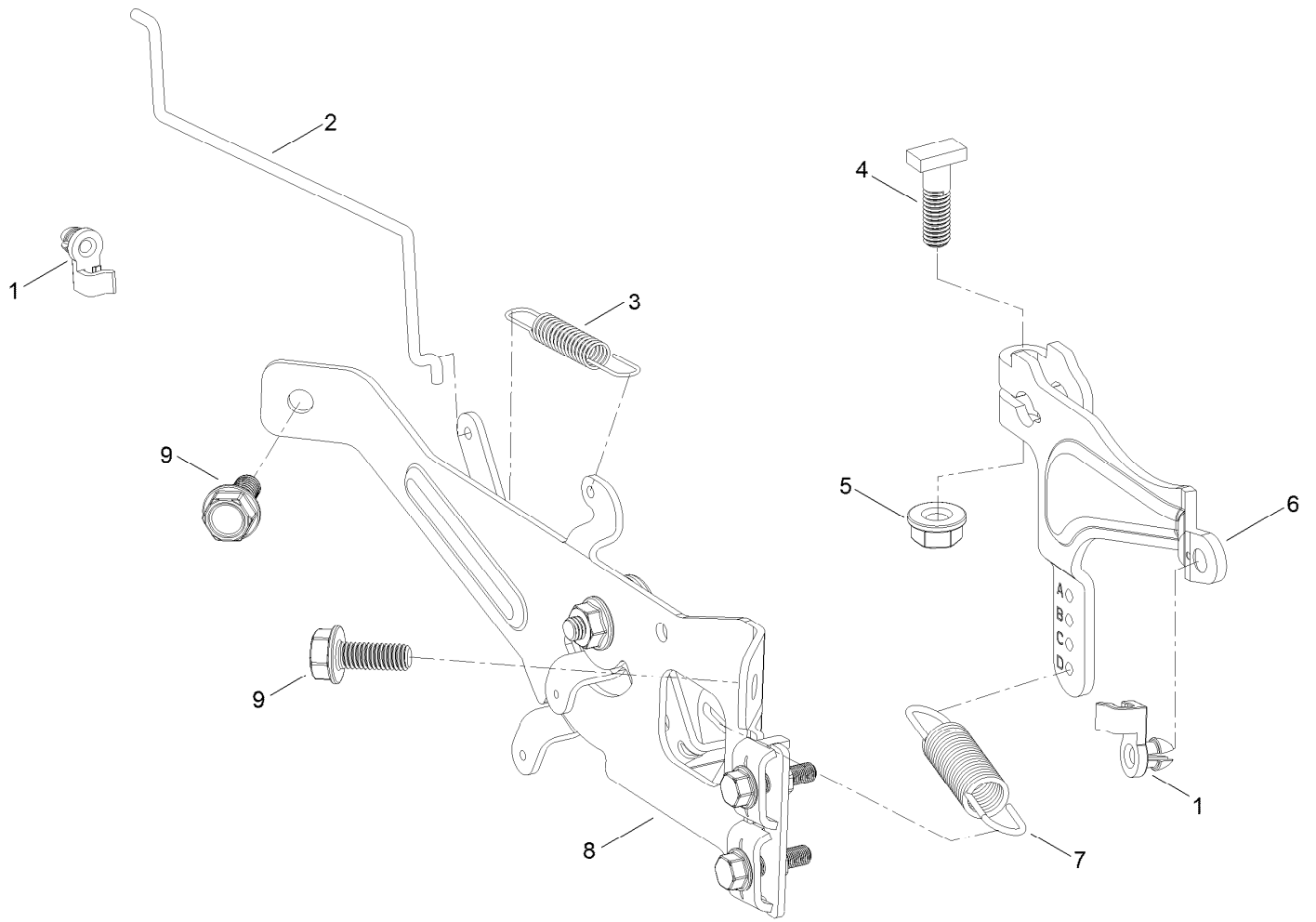

Governor Control Assembly (continued)

<i>Ref.</i>	<i>Part Number</i>	<i>Qty.</i>	<i>Description</i>	<i>Ref.</i>	<i>Part Number</i>	<i>Qty.</i>	<i>Description</i>
1	127-9250	2	Clip-Linkage	6	133-9961	1	Arm-Governor
2	127-9242	1	Linkage-Choke	7	133-9962	1	Spring-Governor
3	127-9241	1	Spring-Governor	8	133-1570	1	Control Plate ASM
4	120-4238	1	Bolt-Arm, Governor	9	120-4232	2	Screw-HHF
5	120-4236	1	Nut-Flange				

Piston and Cylinder Head Assembly

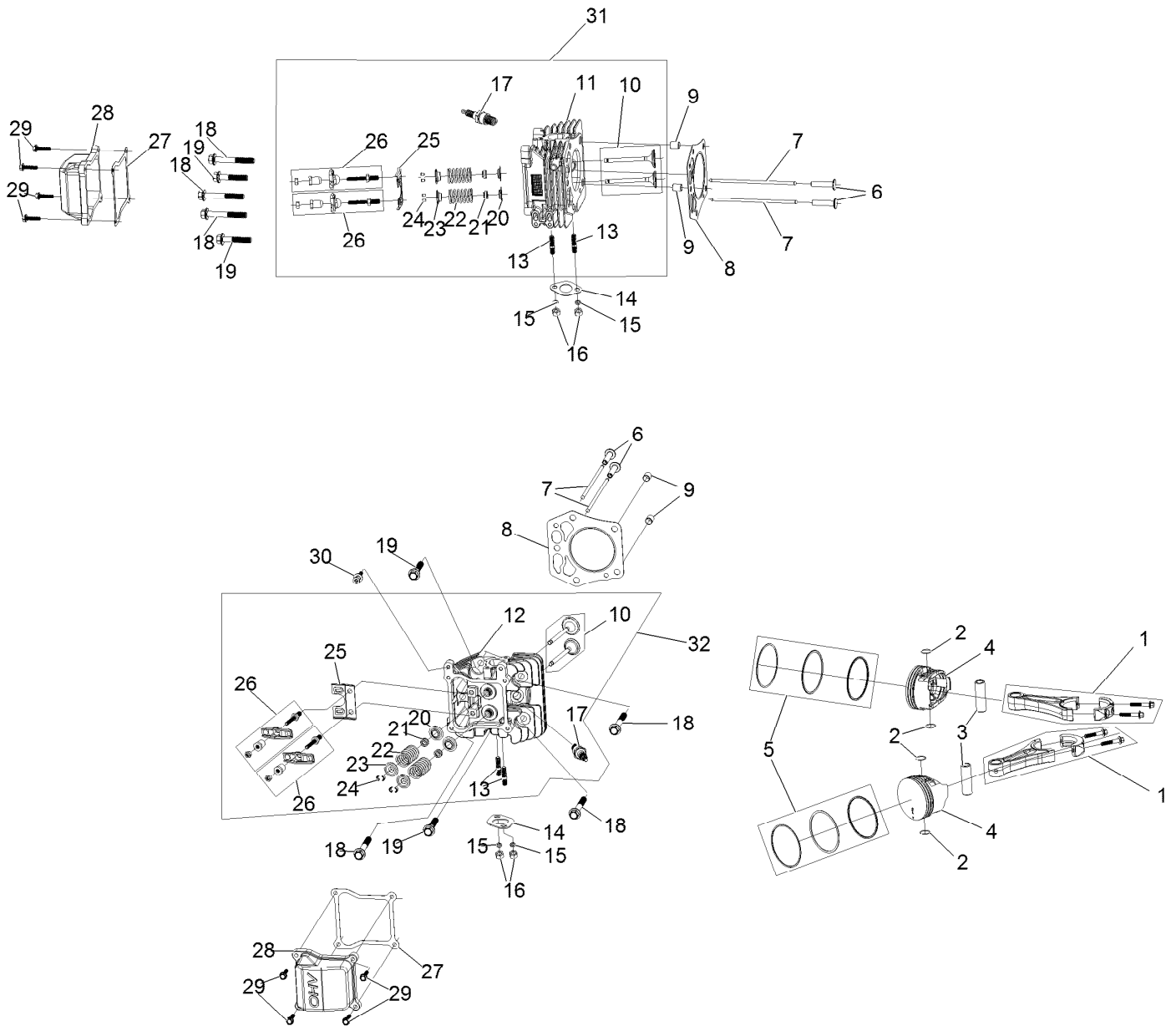

Piston and Cylinder Head Assembly (continued)

<i>Ref.</i>	<i>Part Number</i>	<i>Qty.</i>	<i>Description</i>	<i>Ref.</i>	<i>Part Number</i>	<i>Qty.</i>	<i>Description</i>
1	127-9256	2	Connecting Rod ASM	17	81-3250	2	Spark Plug
2	127-9258	4	Clip-Pin, Piston	18	127-9231	6	Screw-HWH
3	127-9257	2	Pin-Piston	19	127-9232	4	Screw-HWH
4	127-9259	2	Piston	20	120-4303	4	Seat-Spring, Valve
5	127-9260	2	Piston Ring Set	21	120-4304	4	Seal-Stem, Valve
6	127-9224	4	Lifter-Valve	22	120-4305	4	Spring-Valve
7	127-9225	4	Rod-Push	23	120-4306	4	Retainer-Spring, Valve
8	127-9226	2	Gasket-Head, Cylinder	24	120-4307	8	Keeper-Valve
9	127-9227	4	Pin-Dowel	25	127-9233	2	Plate-Guide, Push Rod
10	127-9228	2	Valve Set	26	136-7881	4	Rocker Arm ASM
11	133-9802	1	Head-Cylinder, Right	27	127-9295	2	Gasket-Valve Cover
12	133-9804	1	Head-Cylinder, Left	28	127-9050	2	Cover-Valve
13	121-0464	4	Stud-Exhaust	29	120-4225	8	Screw-HHF
14	120-4317	2	Gasket-Exhaust	30	120-4214	1	Screw-Shoulder, HH
15	127-9279	4	Washer-Lock, Split	31	136-7891	1	Complete Right Head ASM
16	121-0199	4	Nut-HH	32	136-7892	1	Complete Left Head ASM

Blower Housing Assembly

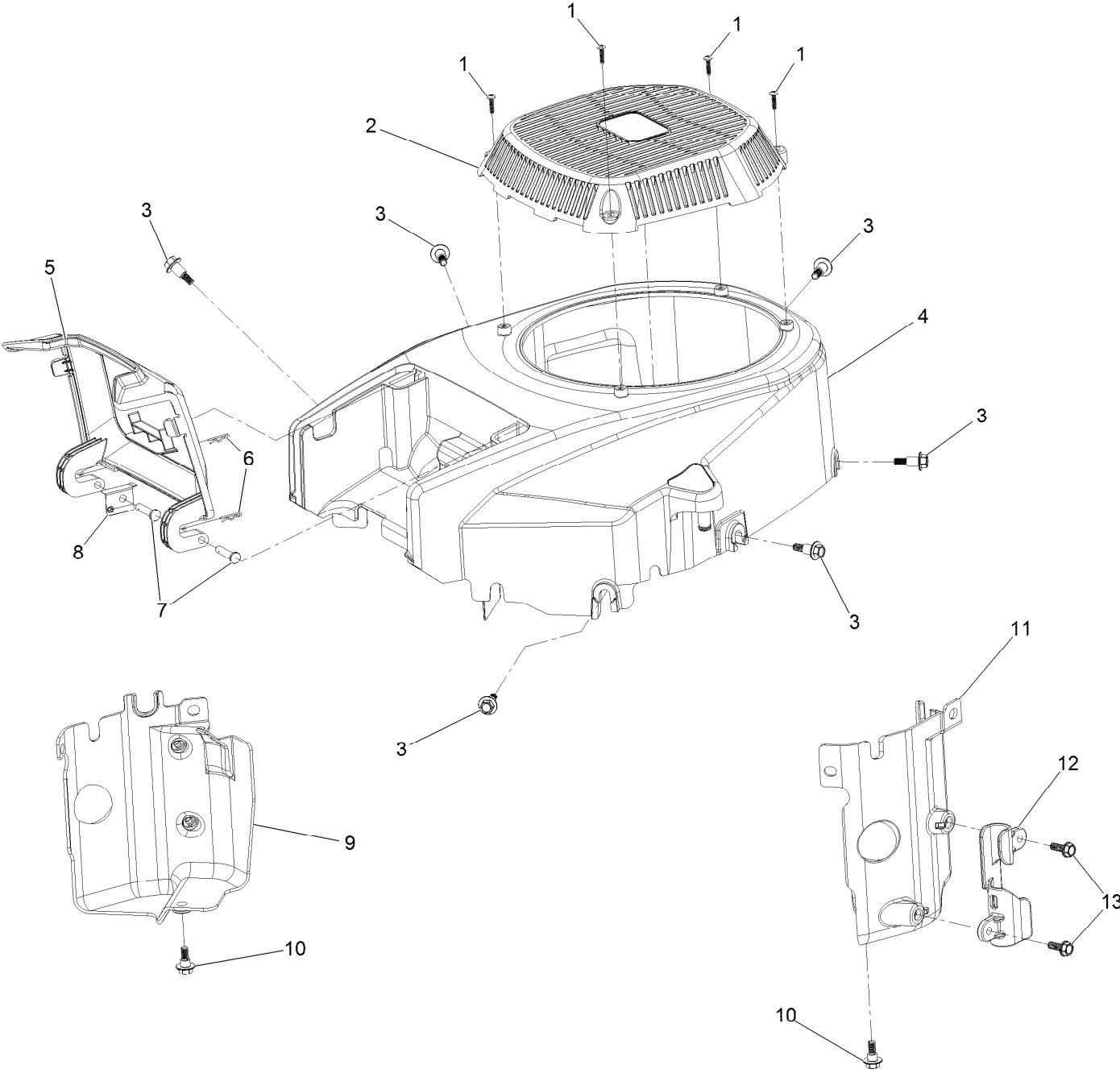

Blower Housing Assembly (continued)

<i>Ref.</i>	<i>Part Number</i>	<i>Qty.</i>	<i>Description</i>	<i>Ref.</i>	<i>Part Number</i>	<i>Qty.</i>	<i>Description</i>
1	133-1571	4	Screw-PPH, Plastic	8	127-9281	1	Plate-Spring
2	127-9045	1	Cover-Fan	9	136-7877	1	Baffle-Air, Left
3	127-9196	6	Screw-Shoulder, HWH	10	120-4210	2	Screw-Shoulder, HHF
4	133-1572	1	Shroud-Engine	11	136-7878	1	Baffle-Air, Right
5	127-9046	1	Door-Filter, Air	12	127-9287	1	Cleat-Hose
6	127-9280	2	Pin-Hair	13	120-4232	2	Screw-HHF
7	127-9282	2	Pin				

Gasket and Seal Kit

1

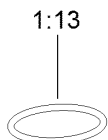
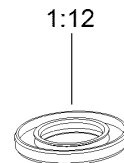
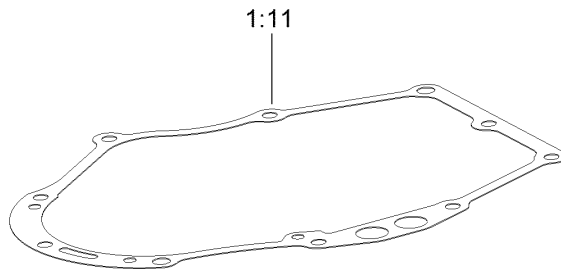
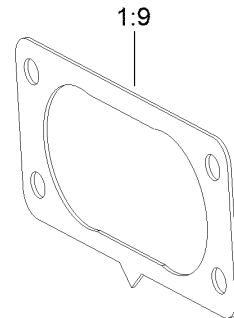
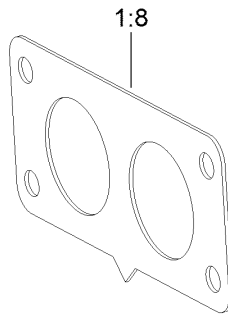
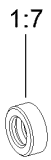
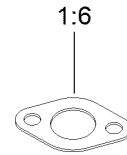
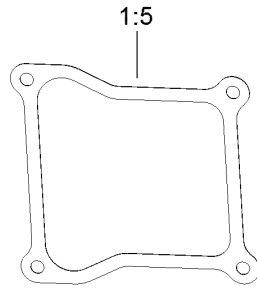
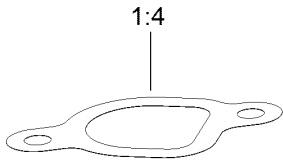
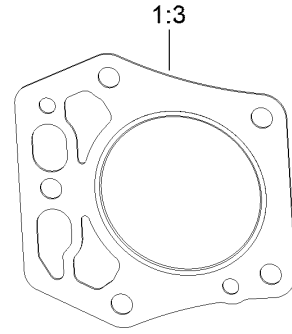
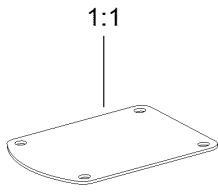

Gasket and Seal Kit (continued)

<i>Ref.</i>	<i>Part Number</i>	<i>Qty.</i>	<i>Description</i>	<i>Ref.</i>	<i>Part Number</i>	<i>Qty.</i>	<i>Description</i>
1	127-9296	1	Gasket And Seal Kit	1:8	127-9246	2	Gasket-Carburetor
1:1	127-9214	1	Gasket-Breather	1:9	127-9251	1	Gasket-Carburetor
1:2	120-4267	1	Seal-Oil	1:10	120-4262	2	O-Ring
1:3	127-9226	2	Gasket-Head, Cylinder	1:11	127-9267	1	Gasket-Cover, Crankcase
1:4	127-9230	2	Gasket-Intake	1:12	127-9271	1	Seal
1:5	127-9295	2	Gasket-Valve Cover	1:13	127-9273	1	O-Ring
1:6	120-4317	2	Gasket-Exhaust	1:14	127-9284	1	O-Ring
1:7	120-4257	1	Seal-Oil	1:15	127-9286	1	O-Ring

Transaxle Drive

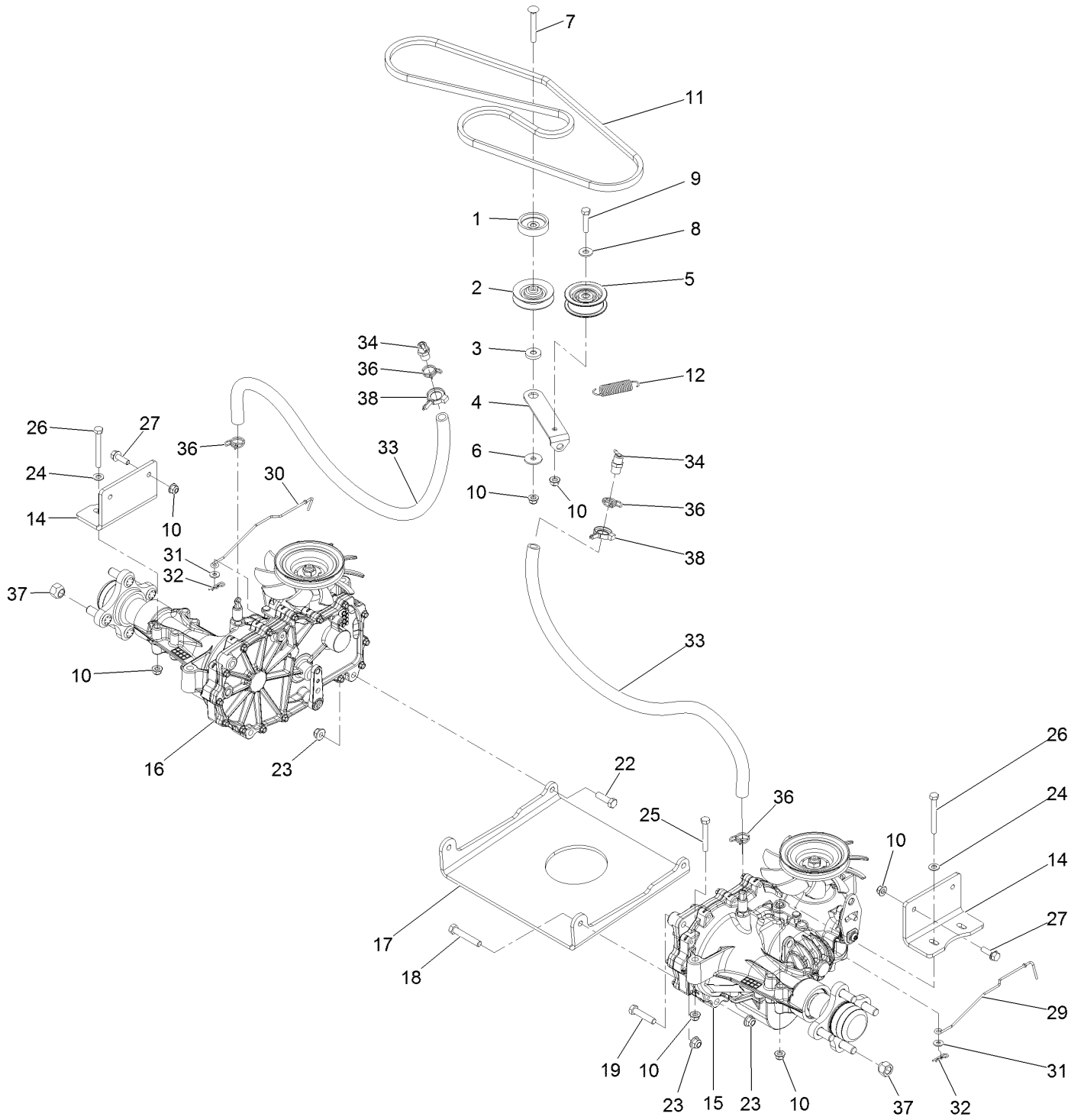

Transaxle Drive (continued)

<i>Ref.</i>	<i>Part Number</i>	<i>Qty.</i>	<i>Description</i>	<i>Ref.</i>	<i>Part Number</i>	<i>Qty.</i>	<i>Description</i>
1	119-3353	1	Spacer	17	130-0718-01	1	Plate-Cross, Hydro
2	119-8822	1	Pulley-Idler	18	323-11	2	Screw-HH 3/8-16 X 2 1/4
3	119-3327	1	Spacer-Arm, Idler	19	323-9	2	Screw-HH 3/8-16 X 1 3/4
4	138-7276	1	Arm-Idler	22	323-7	2	Screw-HH 3/8-16 X 1 1/4
5	138-7597	1	Pulley-Idler, Flat	23	104-8301	6	Nut-Nyloc 3/8-16 Flg
6	5-4460	1	Washer-Pivot	24	3256-23	6	Washer-5/16 SAE
7	3230-8	1	Bolt-Carriage 5/16-18 X 2 1/2	25	322-11	4	Screw-HH 5/16-18 X 2 1/4
8	3256-3	1	Washer-5/16 Std	26	322-13	4	Screw-HH 5/16-18 X 2 3/4
9	322-7	1	Screw-HH 5/16-18 X 1 1/2	27	3234-29	4	Screw-HH Flg 5/16-18 X 1
10	104-8300	14	Nut-Nyloc 5/16-18 Flg	29	130-7048	1	Rod-Bypass, LH
11	130-6976	1	V-Belt	30	130-7047	1	Rod-Bypass, RH
12	137-7040	1	Spring-Return, Pedal	31	119-8952	2	Washer
14	121-0745-01	2	Mount-Hydro	32	3290-307	2	Pin-Cotter
15	130-6960	1	LH Hydro Transmission ASM	33	136-4182	2	Hose-Hydro
16	130-6961	1	RH Hydro Transmission ASM	34	136-4183	2	Breather Kit
				36	117-1193	4	Clamp-Hose
				37	242-50	8	Nut-Lug 1/2-20
				38	105-1853	2	Clamp-Hose

Left Hand Hydro Transaxle Assembly

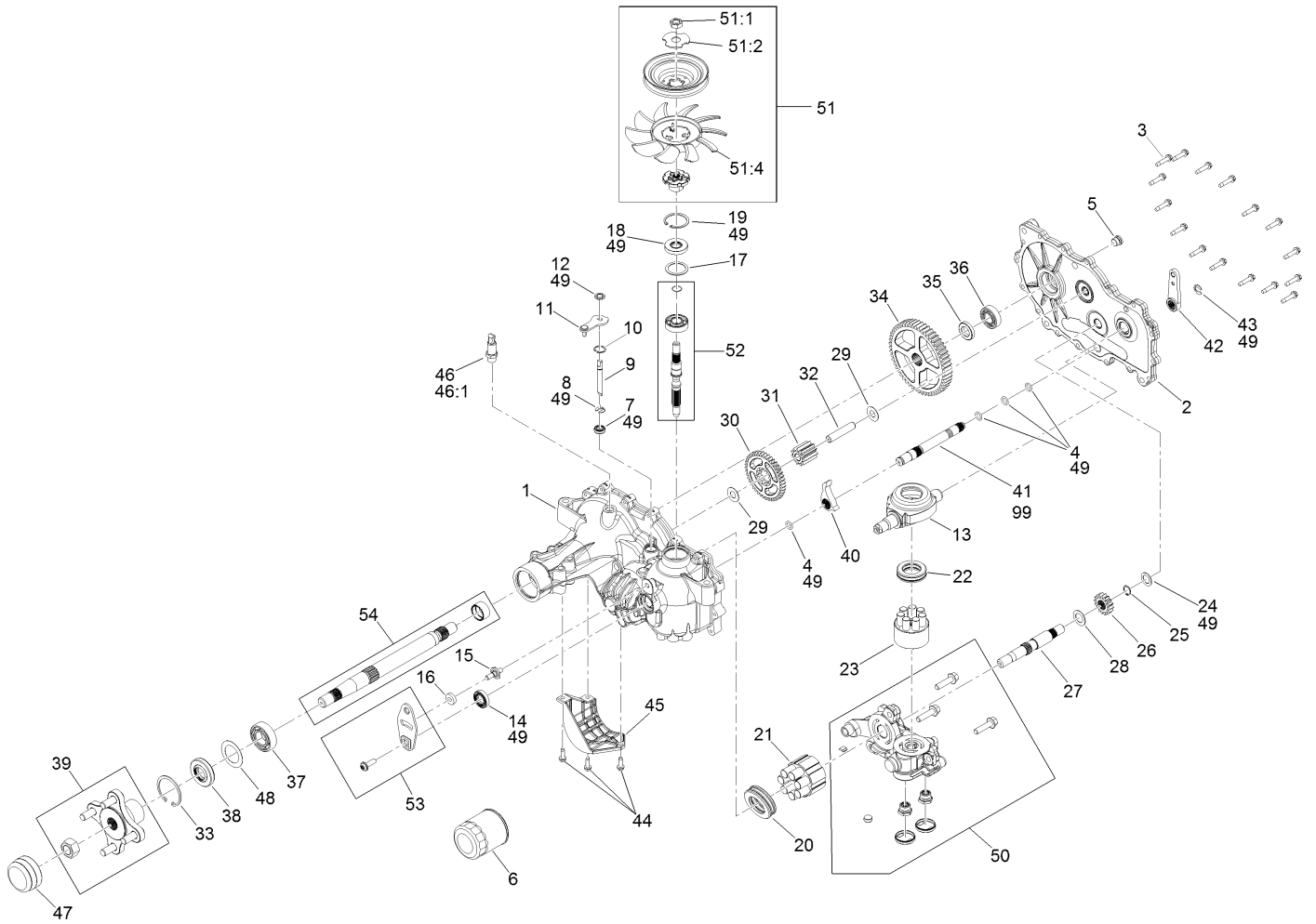

Left Hand Hydro Transaxle Assembly (continued)

<i>Ref.</i>	<i>Part Number</i>	<i>Qty.</i>	<i>Description</i>	<i>Ref.</i>	<i>Part Number</i>	<i>Qty.</i>	<i>Description</i>
1	125-0037	1	Main Housing Kit	31	114-1693	1	Gear-11T
2	132-0939	1	RH Side Cover Kit	32	104-5329	1	Pin-Jackshaft
3	117-5359	16	Screw-HHF	33	104-2169	1	Ring-Retaining
4	114-1678	4	O-Ring	34	114-1694	1	Gear-54T
5	104-2189	1	Plug-Thread, Straight	35	120-7975	1	Spacer
6	109-3321	1	Filter-Hydraulic	36	126-0789	1	Bearing-Ball
7	106-8676	1	Seal-Lip	37	120-7976	1	Bearing-Ball
8	106-8677	1	Ring-Retaining, External	38	104-2144	1	Seal
9	114-1685	1	Rod-Bypass	39	109-5939	1	Hub Kit
10	106-8679	1	Ring-Retaining, Internal	40	114-1697	1	Pawl-Brake
11	112-9852	1	Arm-Bypass	41	114-1698	1	Shaft-Brake, Inboard
12	106-8681	1	Ring-Retaining, External	42	125-0021	1	Handle-Brake
13	104-5304	1	Swashplate-Trunnion	43	131-0906	1	Ring-Retaining, EXT
14	104-5313	1	Seal-Lip	44	104-2120	3	Screw
15	104-2116	1	Stud	45	120-7981	1	Guard-Filter, RH
16	112-9853	1	Puck-Friction	46	109-3278	1	Adapter-Straight
17	104-5308	1	Spacer	46:1	237-42	1	O-Ring
18	104-5310	1	Seal-Lip	47	115-5057	1	Cover-Nut, Axle
19	104-5309	1	Ring-Retaining	48	121-5745	1	Spacer
20	112-4154	1	Bearing-Thrust	49	109-3537	1	Seal Kit
21	114-1689	1	Motor Cylinder Block Kit	50	132-0940	1	RH Center Section Kit
22	94-6922	1	Bearing-Thrust	51	135-7349	1	Fan And Pulley Kit
23	110-8561	1	Pump Block ASM	51:1	116-9714	1	Nut-HJ
24	104-5339	1	Washer-Flat	51:2	116-9708	1	Washer-Slotted
25	104-5340	1	Ring-Retaining	51:4	135-7364	1	Fan 7.0 X 10 Blade
26	121-5749	1	Gear-16T	52	114-8468	1	Input Shaft Kit
27	114-1691	1	Shaft-Motor	53	117-5362	1	Control Arm Kit
28	104-5360	1	Washer	54	114-8470	1	Axle Shaft Kit
29	94-1933	2	Washer	99	135-3604	1	Brake Shaft Seal Kit
30	125-0000	1	Gear-43T				

Right Hand Hydro Transaxle Assembly

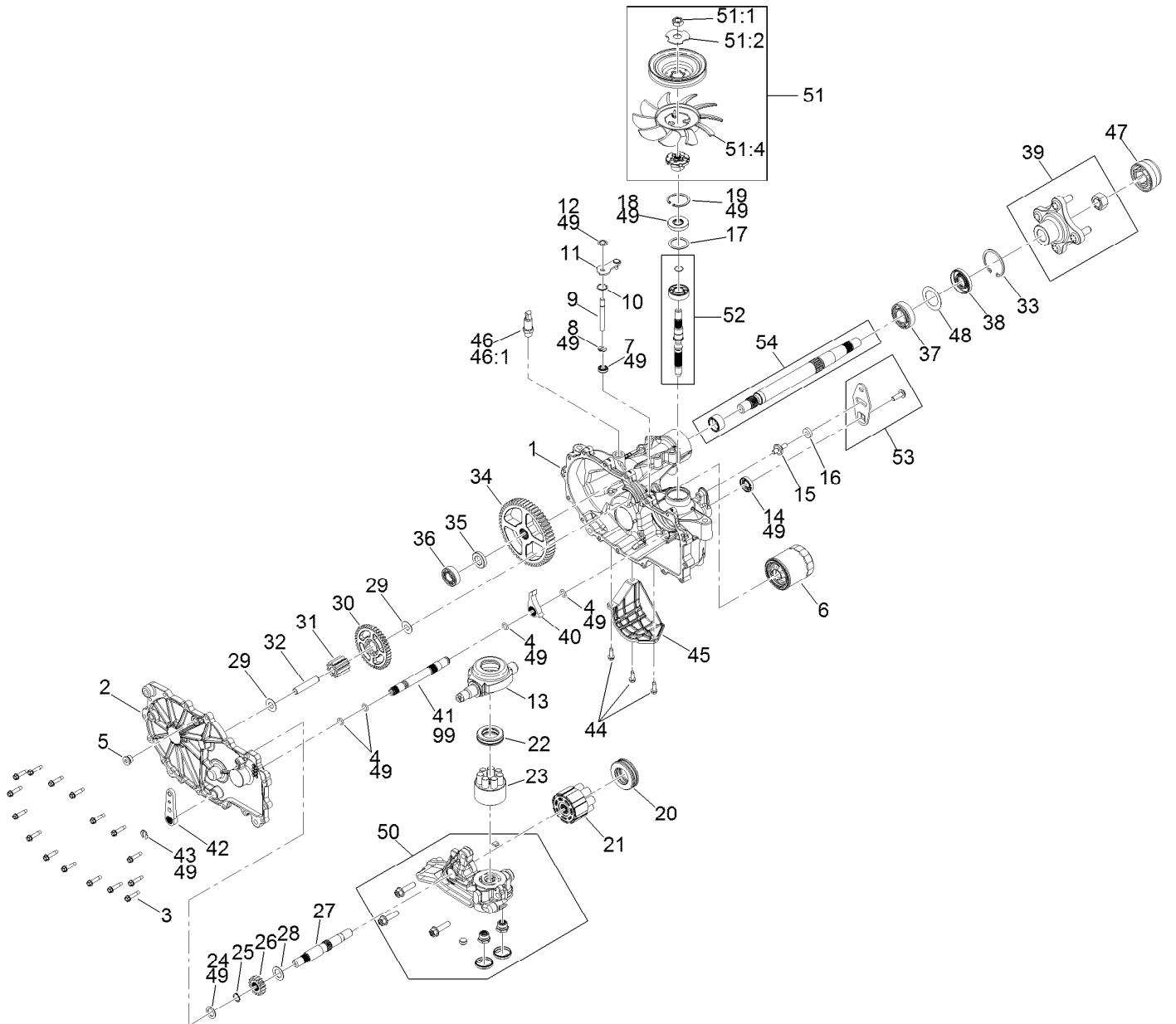

Right Hand Hydro Transaxle Assembly (continued)

<i>Ref.</i>	<i>Part Number</i>	<i>Qty.</i>	<i>Description</i>	<i>Ref.</i>	<i>Part Number</i>	<i>Qty.</i>	<i>Description</i>
1	121-5748	1	Main Housing Kit	31	114-1693	1	Gear-11T
2	132-0938	1	LH Side Cover Kit	32	104-5329	1	Pin-Jackshaft
3	117-5359	16	Screw-HHF	33	104-2169	1	Ring-Retaining
4	114-1678	4	O-Ring	34	114-1694	1	Gear-54T
5	104-2189	1	Plug-Thread, Straight	35	120-7975	1	Spacer
6	109-3321	1	Element-Oil Filter, HYD	36	126-0789	1	Bearing-Ball
7	106-8676	1	Seal-Lip	37	120-7976	1	Bearing-Ball
8	106-8677	1	Ring-Retaining, External	38	104-2144	1	Seal
9	114-1685	1	Rod-Bypass	39	109-5939	1	Hub Kit
10	106-8679	1	Ring-Retaining, Internal	40	114-1697	1	Pawl-Brake
11	107-2490	1	Arm-Bypass	41	114-1698	1	Shaft-Brake, Inboard
12	106-8681	1	Ring-Retaining, External	42	125-0021	1	Handle-Brake
13	104-5304	1	Swashplate-Trunnion	43	131-0906	1	Ring-Retaining, EXT
14	104-5313	1	Seal-Lip	44	104-2120	3	Screw
15	104-2116	1	Stud	45	120-7979	1	Guard-Filter, LH
16	112-9853	1	Puck-Friction	46	109-3278	1	Adapter-Straight
17	104-5308	1	Spacer	46:1	237-42	1	O-Ring
18	104-5310	1	Seal-Lip	47	115-5057	1	Cover-Nut, Axle
19	104-5309	1	Ring-Retaining	48	121-5745	1	Spacer
20	112-4154	1	Bearing-Thrust	49	109-3537	1	Seal Kit
21	114-1689	1	Motor Cylinder Block Kit	50	125-0036	1	Center Section Kit
22	94-6922	1	Bearing-Thrust	51	135-7349	1	Fan And Pulley Kit
23	110-8561	1	Pump Block ASM	51:1	116-9714	1	Nut-HJ
24	104-5339	1	Washer-Flat	51:2	116-9708	1	Washer-Slotted
25	104-5340	1	Ring-Retaining	51:4	135-7364	1	Fan 7.0 X 10 Blade
26	121-5749	1	Gear-16T	52	114-8468	1	Input Shaft Kit
27	114-1691	1	Shaft-Motor	53	117-5362	1	Control Arm Kit
28	104-5360	1	Washer	54	114-8470	1	Axle Shaft Kit
29	94-1933	2	Washer	99	135-3604	1	Brake Shaft Seal Kit
30	125-0000	1	Gear-43T				

Electrical Assembly

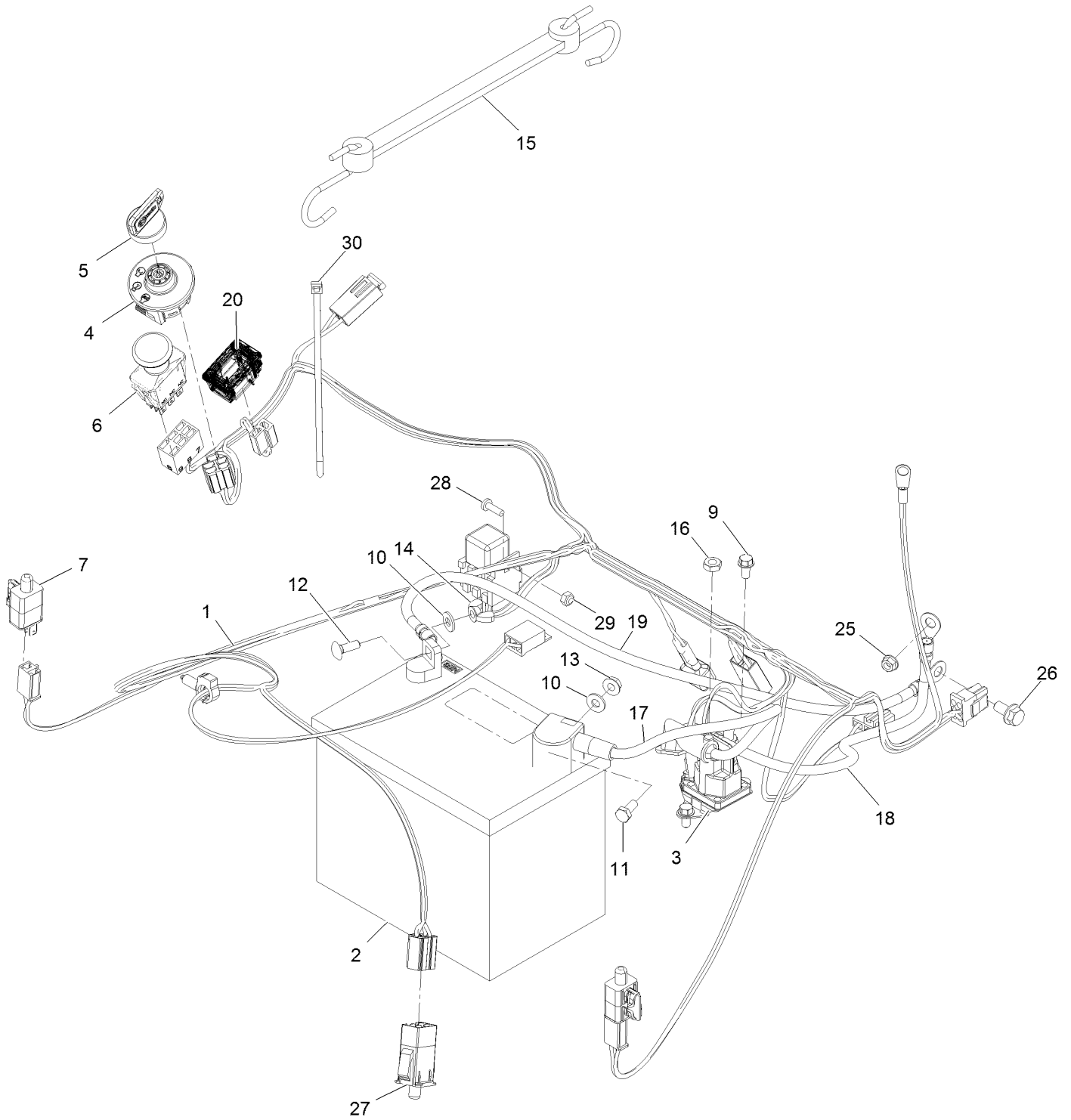

Electrical Assembly (continued)

<i>Ref.</i>	<i>Part Number</i>	<i>Qty.</i>	<i>Description</i>	<i>Ref.</i>	<i>Part Number</i>	<i>Qty.</i>	<i>Description</i>
1	142-2279	1	Harness-Wire, ●	14	32103-22	1	Nut-Wing
2	105-1692	1	Battery	15	104-2466	1	Holddown-Battery
3	117-1197	1	Solenoid	16	139-2580	2	Nut-HJ
4	137-4100	1	Switch-Ignition	17	119-8897	1	Cable-Battery, Red
5	103-2106	1	Key-Exmark Logo	18	121-0711	1	Cable-Battery, Positive
6	103-5221	1	Switch-PTO	19	119-8899	1	Cable-Battery, Black
7	110-6765	2	Switch	20	126-3931	1	Meter-Hour
9	32144-4	2	Screw-HWH 1/4-20 X 1/2 Taptite	25	33003-00	1	Nut-Hex M6-1 Flg
10	120-9679	2	Washer-Flat	26	3234-14	1	Screw-HH Flg 5/16-18 X 5/8
11	137-3041	1	Screw-HH	27	104-3338	1	Switch-Delta
12	3229-1	1	Bolt-Carriage 1/4-20 X 3/4	28	3290-500	1	Screw-PPH #10-24 X 5/8
13	139-2575	1	Nut-HF	29	3296-2	1	Nut-Nyloc #10-24
				30	614249	1	Tie-Cable

● Use dielectric grease on all unsealed connectors and terminals only. Do not apply in sealed connectors.

Notes:

Notes:

Notes:



MAXIMIZE THE PERFORMANCE OF YOUR EXMARK MACHINE.



EXMARK® PREMIUM ENGINE OIL

Exmark now offers a family of engine oil viscosities to perform well in any environment. Each viscosity has the same synthetic formulation to give you what you need in punishing conditions. We designed each grade to the highest quality, making it ideal even for diesel applications. Coupled with Exmark Premium Fuel Treatment, we have the performance products to make your machine hum.

EXMARK PREMIUM ENGINE OIL SAE 30/10W-30

- Meets zero shear requirements of a straight grade SAE 30 as well as the cold temp properties of a 10W-30.
- Most versatile oil in the industry.
- Superior corrosion protection over conventional oil - even in corrosive, humid environments.

EXMARK PREMIUM ENGINE OIL SAE 20W-50

- Perfect for your big block engine, or any application in severe service.
- Same full synthetic formulation as all other Exmark Premium viscosities.
- Also effective for use in severe service small block engines.

EXMARK PREMIUM ENGINE OIL SAE 10W-50

- Full synthetic formulation gives you peak performance. Don't settle for less.
- Wide span multi-grade combines easy starting in cold weather with maximum protection in high temperature operation.
- Reduce friction & wear over standard mineral formulations.

EXMARK PREMIUM ENGINE OIL SAE 0W-40

- The perfect choice for when the weather turns cold or unpredictable, and your Exmark UTV has to perform.
- Commercial quality for severe service.
- Advanced additive package helps prevent corrosion from long-term storage.

EXMARK PREMIUM ENGINE OIL UTV FORMULATION

- 4-cycle high-temp formulation.
- Heavier viscosity, full synthetic, perfect for your UTV.

EXMARK PREMIUM UTV EXTREME CONDITIONS GEAR OIL

- SAE 80W-90, designed to keep your UTV performing at its peak.
- Shear stable, hypoid gear lube.
- Includes a premium additive system to combat wear, oxidation, rust & corrosion.

Available from your local Exmark dealer. Find your closest dealer at exmark.com

EXMARK ACCESSORIES AND OPTIONS*

MID-MOUNT RIDING ACCESSORIES AND OPTIONS

CUSTOM RIDE SEAT SUSPENSION SYSTEM	OPERATOR CONTROLLED DISCHARGE
FULL SUSPENSION SEAT	SUN SHADE
DECK LIFT ASSIST KIT	TRASH CONTAINER
HITCH KIT	TURF STRIPER
LIGHT KIT	ULTRA VAC COLLECTION SYSTEM
12V POWER PORT	ULTRA VAC QUICK DISPOSAL SYSTEM
MICRO-MULCH SYSTEM	

OUT-FRONT RIDING ACCESSORIES AND OPTIONS

CUSTOM RIDE SEAT SUSPENSION SYSTEM	SNOW BLADE
DUAL-TAIL WHEEL	SNOWBLOWER
FLOOR PAN EXTENDER	SUN SHADE
HITCH KIT	TRASH CONTAINER
LIGHT KIT	ULTRA VAC COLLECTION SYSTEM
MICRO-MULCH SYSTEM	ULTRA VAC QUICK DISPOSAL SYSTEM
ROLL OVER PROTECTION SYSTEM (ROPS)	WEATHER CAB

WALK-BEHIND ACCESSORIES AND OPTIONS

GRASS CATCHER	TURF STRIPER
MICRO-MULCH SYSTEM	STANDON

*Some accessories and options not available for some models.

Place Model No. and Serial No.
Label Here (Included in the Literature
Pack) or Fill in Below

Model No. _____

Serial No. _____

Date Purchased _____

Engine Model No. and Spec. No. _____

Engine Serial No. (E/No) _____

© 2019 Exmark Mfg. Co., Inc.
2101 Ashland Ave
Beatrice, NE 68310
All Rights Reserved

Part No. 4504-746 Rev. A
(402) 223-6375
Fax (402) 223-5489
Printed in the USA.

