

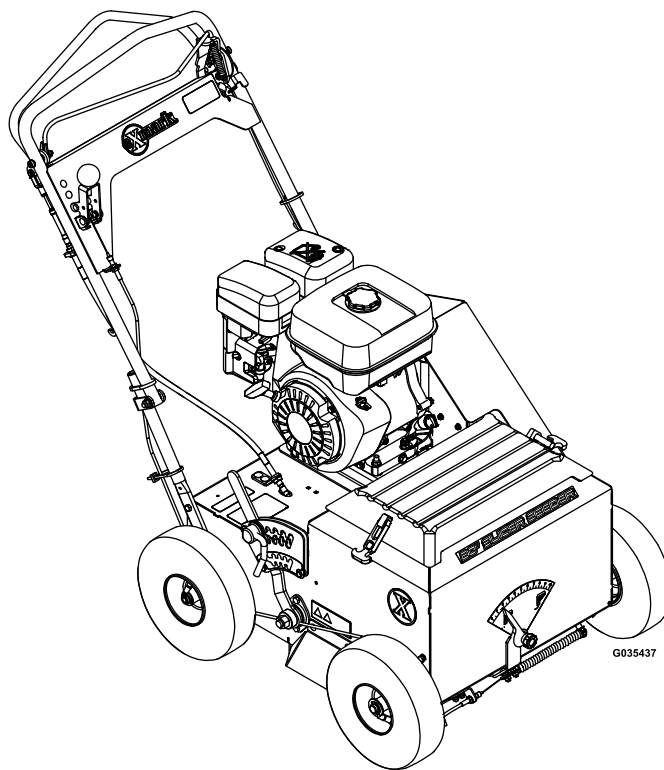

SLICER SEEDER

Model No. SDS395CKC20000—Serial No. 406294345 and Up

Picture below may not reflect actual product.



Parts Manual

Part No. 4504-684 Rev. A

Ordering Replacement Parts

To order replacement parts, please supply the part number, the quantity, and the description of each part desired.

Understanding Reference Numbers

Each identified part in an illustration has a reference number. The reference number for a part also appears in the parts list, along with other information about the part.

This catalog uses two special reference number formats, one to indicate parts in a service assembly and another to indicate the quantity of a given part in an illustration.

Service Assembly Reference Numbers

Parts in service assemblies have reference numbers in the form a:b. The a represents the reference number of the entire service assembly and the b represents a sequential number unique to each part within the service assembly.

For example, a wheel assembly might be identified by reference number 6, the tire by 6:1, the valve by 6:2, and the wheel by 6:3. When you order the assembly identified by reference number 6, you receive all parts identified by reference numbers 6:1, 6:2, and 6:3. However, you may also order any part individually. Reference numbers of this type appear in illustration and in parts lists.

Reference Numbers Indicating Quantity

In an illustration, if a reference number indicates more than one part, the reference number has the form nX y. The n represents the quantity of the part, the X is the multiplication symbol, and the y represents the reference number.

For example, in an illustration, the reference number 2X 37 means that two of the parts identified by reference number 37 are indicated.

Touch Up Paint

Exmark black touch up spray paint – gloss black.

Exmark red touch up paint (spray paint – P/N 1-850337 - .6 oz liquid bottle – P/N 103-9140).



If your Exmark dealer does not have the Exmark part in stock, Exmark will get the parts to the dealer the next business day or the part will be FREE Guaranteed!! (Some restrictions apply. See your participating Exmark Dealer for details.)

Contents

Main Frame Assembly	4
Main Frame Assembly W/Decals	6
Handle Assembly	8
Cutting Wheel Assembly	10
Shaft Assembly	12
Seed Gate Assembly	14
Belt Drive Assembly	16
Transmission Assembly	18

Main Frame Assembly

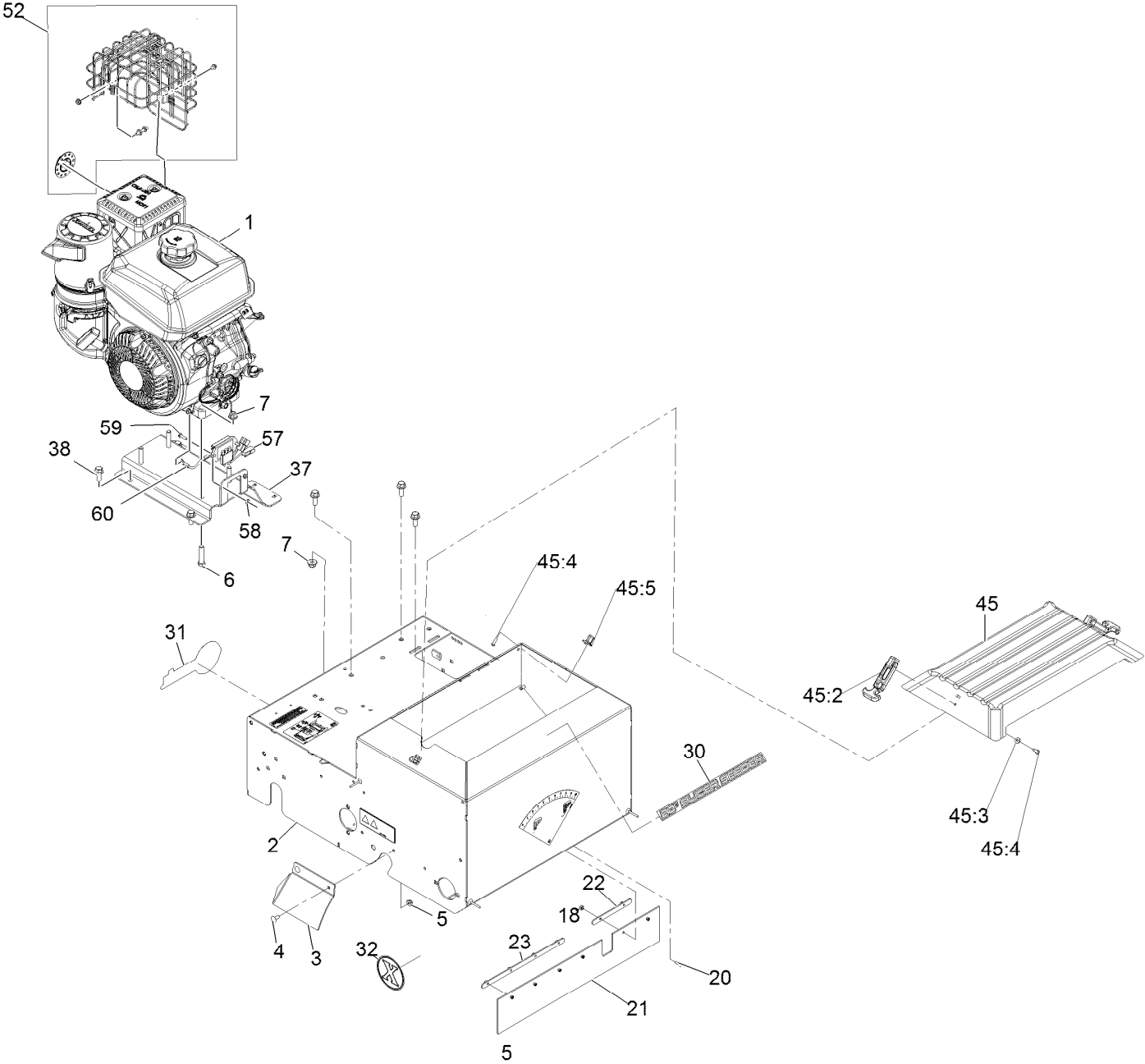

Main Frame Assembly (continued)

<i>Ref.</i>	<i>Part Number</i>	<i>Qty.</i>	<i>Description</i>	<i>Ref.</i>	<i>Part Number</i>	<i>Qty.</i>	<i>Description</i>
1		1	Engine-Kohler, Ch395 ●	32	126-7194	2	Decal-X-Logo
2	121-6196	1	Frame ASM	37	135-0690-01	1	Plate-Engine
3	121-1896-01	1	Guard-RH	38	3234-42	3	Screw HHF 3/8-16 X 1
4	3229-11	2	Bolt-Carriage 1/4-20 X 5/8	45	126-1665	1	Seeder Cover Kit
5	104-7201	2	Nut-Nyloc 1/4-20 Flg	45:2	103-4080	2	Latch-Rubber
6	323-9	4	Screw-HH 3/8-16 X 1 3/4	45:3	3256-14	4	Washer-#10 Std
7	104-8301	7	Nut-Nyloc 3/8-16 Flg	45:4	3290-500	6	Screw-PPH #10-24 X 5/8
18	3296-1	6	Nut-Nyloc #8-32	45:5	103-4081	2	Latch-Keeper
20	3290-392	6	Screw-SHH #8-32 X 5/8	52	135-7340	1	Kit-Ch395 Muffler Guard
21	121-1990	1	Guard-Dust	57	135-3924	1	Regulator
22	121-1991	1	Plate-Retainer	58	32149-7	2	Nut-Keps
23	121-1992	1	Plate-Retainer	59	32105-13	2	Screw-HWH #10-24 X 3/4
30	126-7031	1	Decal-Slicer Seeder Logo	60	135-7760	1	Harness-Jumper, Regulator Ground
31	126-6877	1	Decal, Exmark Logo				

● Not serviced separately

Main Frame Assembly W/Decals

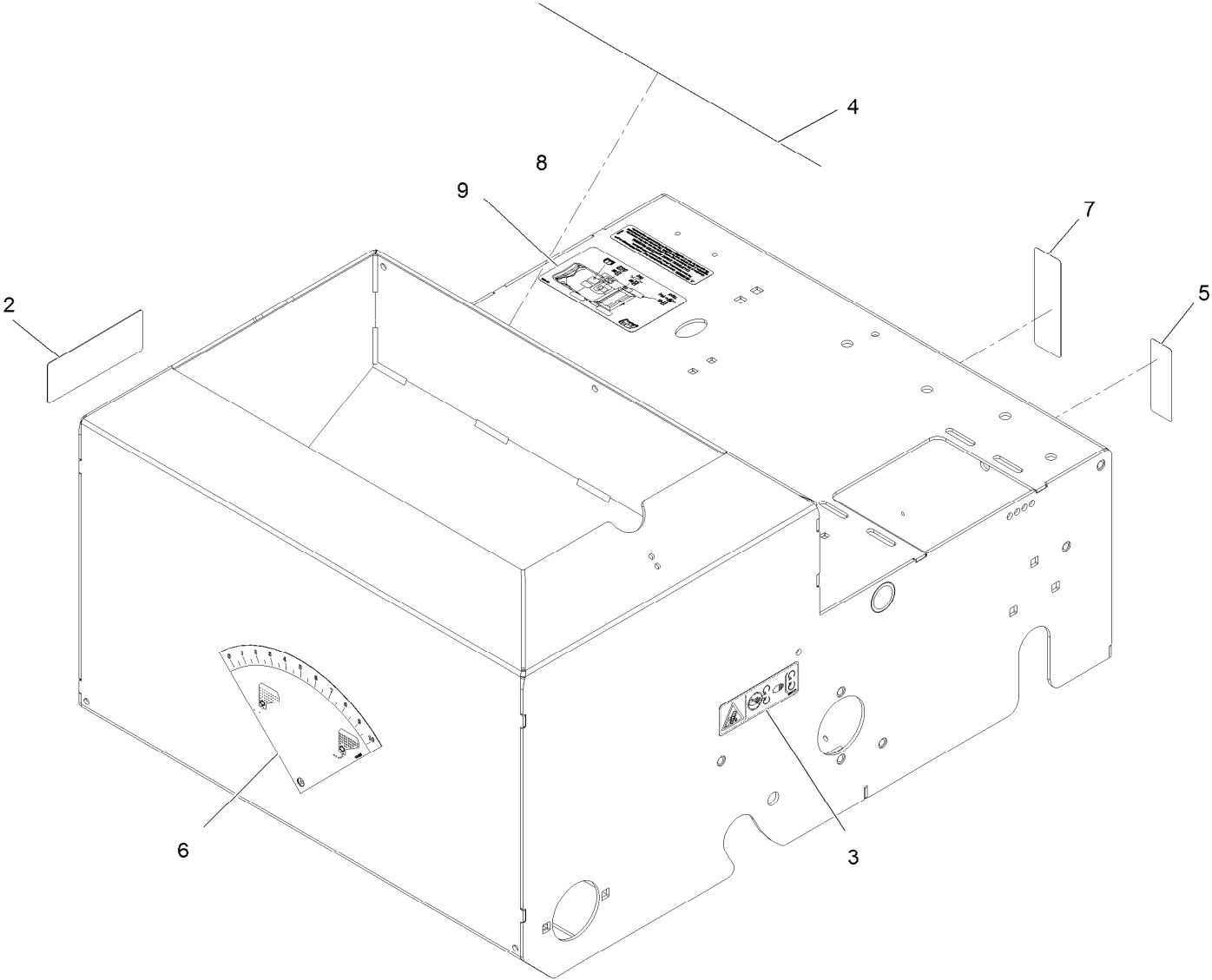

Main Frame Assembly W/Decals (continued)

<i>Ref.</i>	<i>Part Number</i>	<i>Qty.</i>	<i>Description</i>	<i>Ref.</i>	<i>Part Number</i>	<i>Qty.</i>	<i>Description</i>
2	93-7321	1	Decal-Danger	6	116-8535	1	Decal-Flow, Seed
3	117-4979	1	Decal-Warning, Shields	7	121-6203	1	Decal-Bypass
4	121-2011	1	Decal-Warning	8	133-8062	1	Decal-Arrestor, Spark
5	115-9625	1	Decal-Brake, Parking	9	126-0296	1	Decal-Aid, Service

Handle Assembly

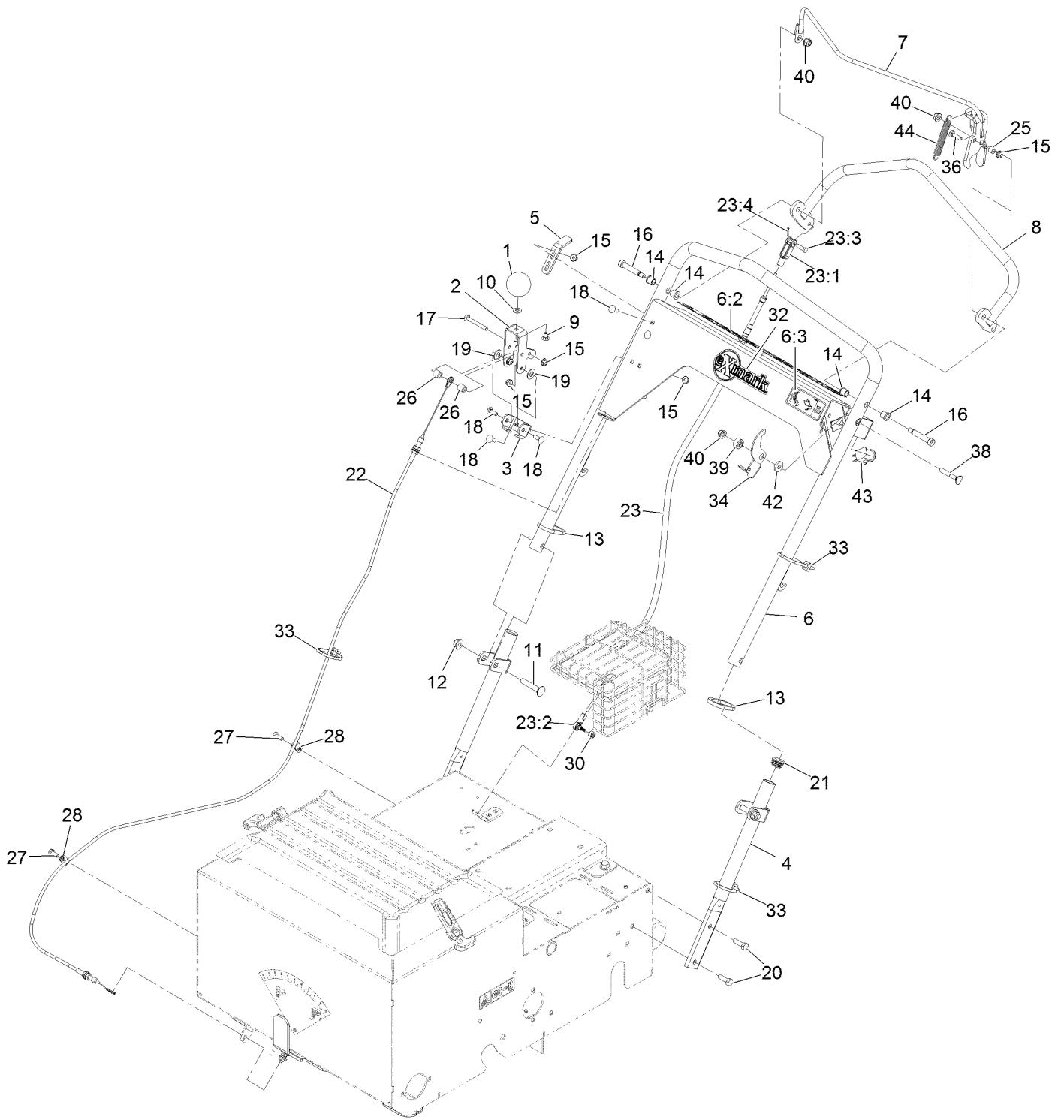

Handle Assembly (continued)

<i>Ref.</i>	<i>Part Number</i>	<i>Qty.</i>	<i>Description</i>	<i>Ref.</i>	<i>Part Number</i>	<i>Qty.</i>	<i>Description</i>
1	121-1877	1	Knob-Rate, Flow	21	121-4870	2	Plug
2	121-1878	1	Lever-Adjust, Flow	22	126-0042	1	Cable-Flow, Seed
3	121-1879	1	Bracket-Adjust, Flow	23	116-8252	1	Cable-Push Pull
4	121-1893-03	2	Handle-Lower	23:1	121-2000	1	Clevis
5	121-1928	1	Bracket-Adjust, Drive	23:2	117-9720	1	Ball Joint
6	116-9735	1	Handle	23:3	283-67	1	Pin-Clevis
6:2	116-8648	1	Decal-Control Panel, Seeder	23:4	3272-5	1	Pin-Cotter 3/32 X 1/2
6:3	116-8536	1	Decal-Safety Latch	25	66-8010	1	Spacer
7	126-0509-03	1	Bail-Clutch	26	22-7810	2	Spacer
8	121-1948-03	1	Handle-Drive	27	321-3	2	Screw-HH 1/4-20 X 5/8
9	3229-10	1	Bolt-Carriage 1/4-20 X 1/2 ●	28	2412-149	2	Clamp-R
10	3256-22	1	Washer-1/4 SAE	30	3296-3	1	Nut-Nyloc 1/4-28
11	3231-6	2	Bolt-Carriage 3/8-16 X 2	32	126-6575	1	Decal-Exmark Logo
12	104-8301	2	Nut-Nyloc 3/8-16 Flg	33	3290-378	3	Tie-Cable
13	121-6202	2	Ring-Handle Lock	34	126-0205	1	Latch-Bail
14	103-9928	4	Bearing	36	3229-2	1	Bolt-Carriage 1/4-20 X 1
15	104-7201	8	Nut-Nyloc 1/4-20 Flg	38	112-8876	1	Bolt-Carriage 5/16-18 X 2
16	126-0277	2	Screw-Shoulder	39	116-2690	1	Bushing-Stepped
17	321-11	1	Screw-HH 1/4-20 X 2	40	104-8300	3	Nut-Nyloc 5/16-18 Flg
18	3229-1	6	Bolt-Carriage 1/4-20 X 3/4	42	88-7200	1	Washer-Flat
19	48-9220	2	Washer-Plain	43	82-2190	1	Switch
20	322-5	4	Screw-HH 5/16-18 X 1	44	95-3805	1	Spring

● Use Pro-Lock, Nut Type (P/N 1-840022, .5ml tube) on threads.

Cutting Wheel Assembly

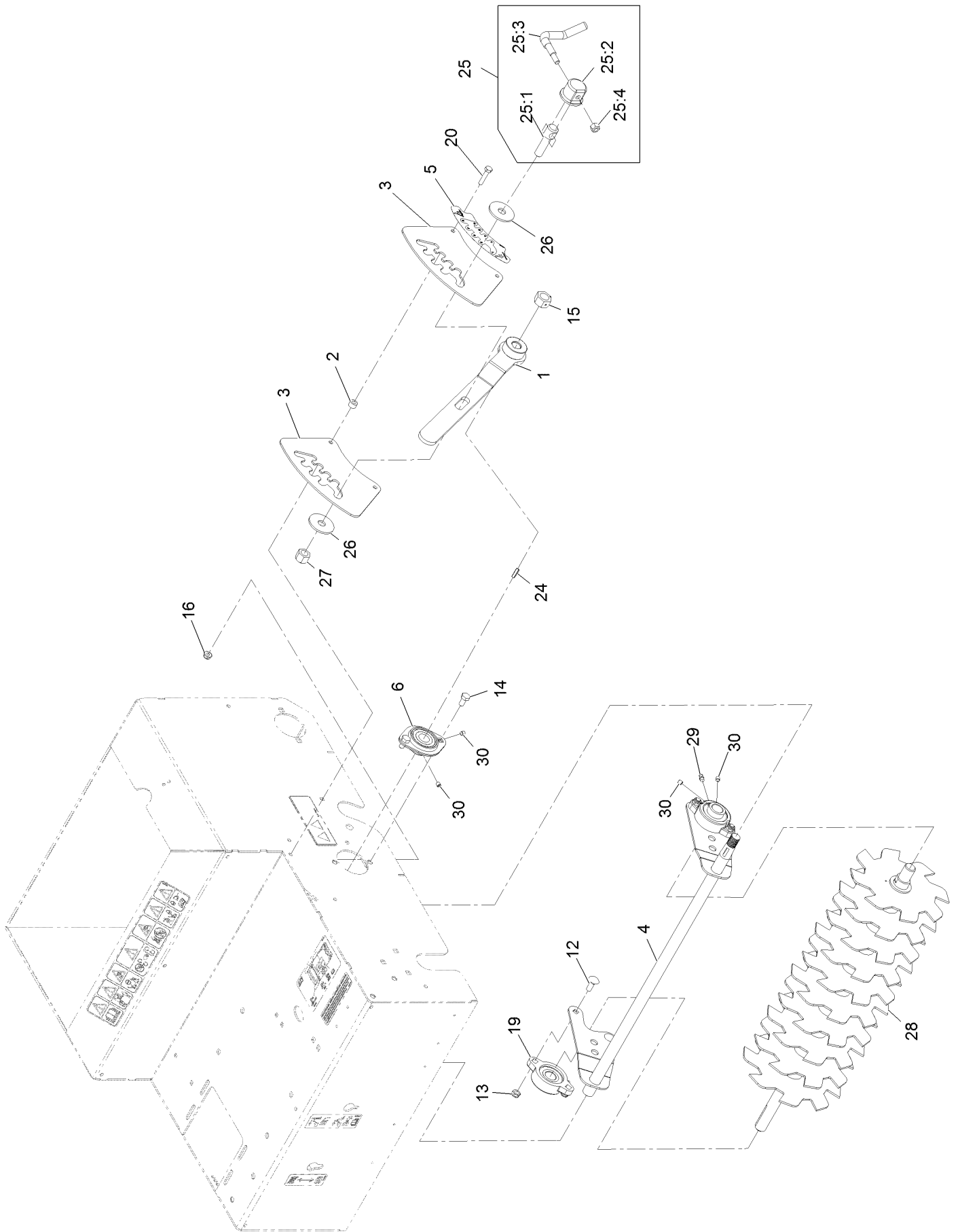

Cutting Wheel Assembly (continued)

<i>Ref.</i>	<i>Part Number</i>	<i>Qty.</i>	<i>Description</i>	<i>Ref.</i>	<i>Part Number</i>	<i>Qty.</i>	<i>Description</i>
1	116-9932-03	1	Handle-Height	20	321-8	2	Screw-HH
2	98-4799	2	Spacer	24	3257-5	1	Key-Woodruff
3	116-9928	2	Plate-Height	25	107-1664	1	Lever ASM
4	126-0010-03	1	Pivot-Height	25:1	106-3239	1	Screw-Lock
5	126-2446	1	Decal-Cut Depth, Slicer/Seeder	25:2	107-1644	1	Cap-Lock
6	121-1961	2	Bearing	25:3	106-3241	1	Lever-Lock
12	3230-16	4	Screw-CARR	25:4	3296-29	1	Nut-Lock, NI
13	3296-47	4	Nut-Lock, NI	26	86-1990	2	Washer-Thrust
14	322-2	4	Screw-HH	27	3296-23	1	Nut-Lock, NI
15	603164	1	Nut-Blade	28	126-0034	1	Slicer Shaft ASM
16	104-7201	2	Nut-HF	29	302-19	2	Fitting-Grease ●
19	116-9992	2	Bearing-Flange	30	3245-35	8	Screw-Set, HSH ●

● Use Pro-Lock, Nut Type (P/N 1-840022, .5ml tube) on threads.

Shaft Assembly

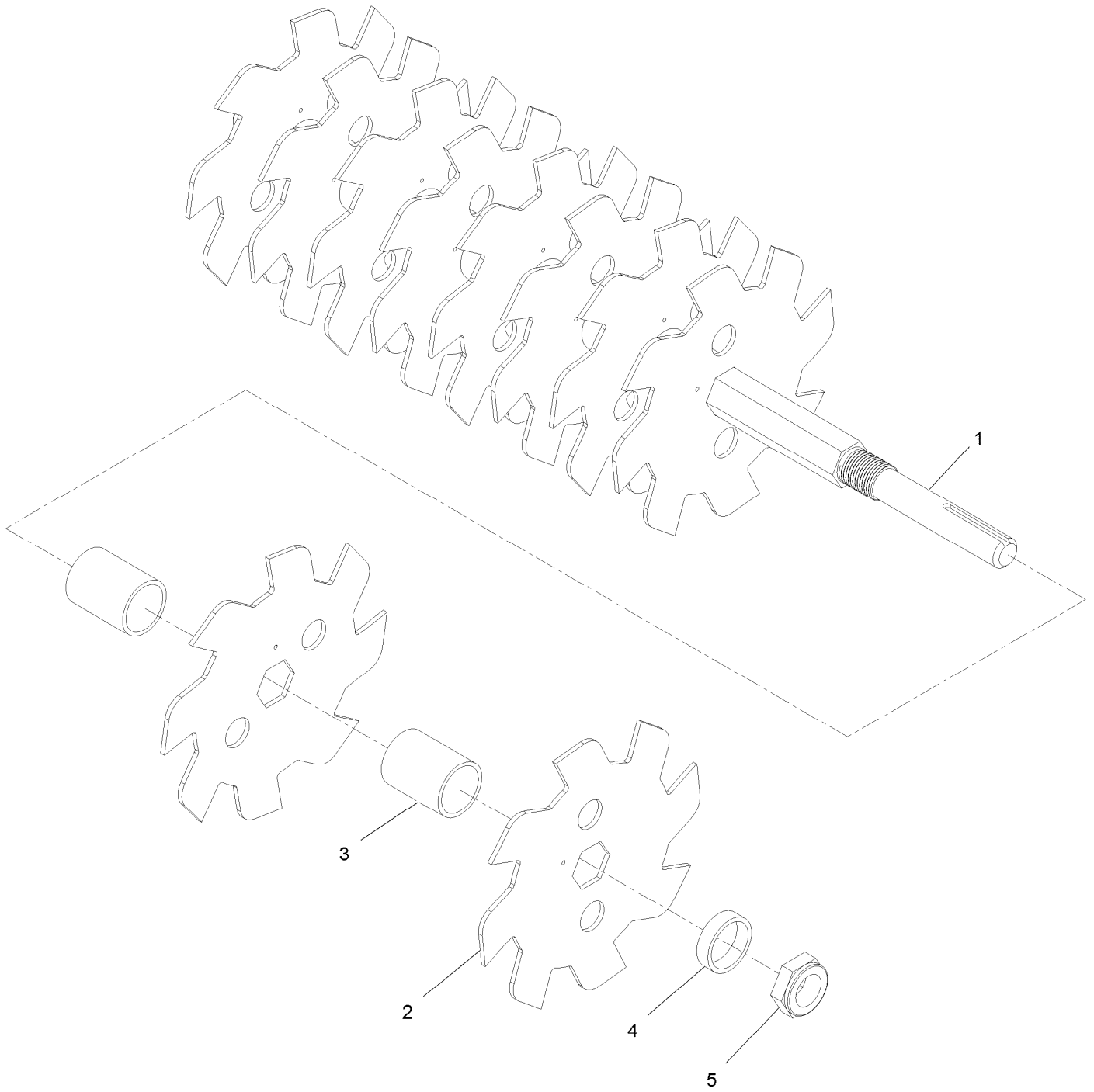

Shaft Assembly (continued)

<i>Ref.</i>	<i>Part Number</i>	<i>Qty.</i>	<i>Description</i>	<i>Ref.</i>	<i>Part Number</i>	<i>Qty.</i>	<i>Description</i>
1	126-0009	1	Shaft-Slicer	4	126-0033	1	Spacer
2	135-3955	10	Blade-Cutting, Seeder	5	3296-60	1	Nut-Nyloc 7/8-14
3	126-0041	9	Spacer-Blade				

Seed Gate Assembly

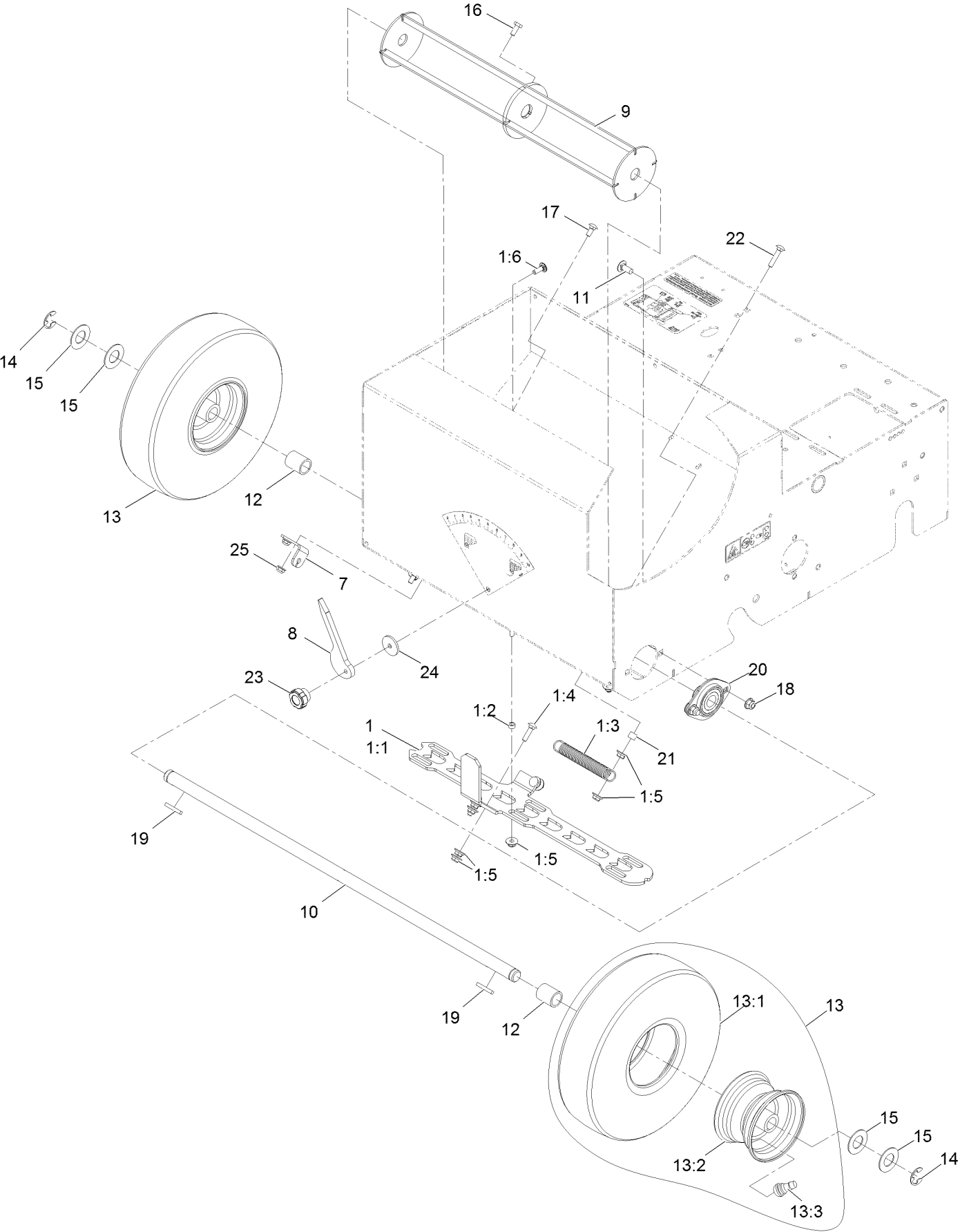

Seed Gate Assembly (continued)

<i>Ref.</i>	<i>Part Number</i>	<i>Qty.</i>	<i>Description</i>	<i>Ref.</i>	<i>Part Number</i>	<i>Qty.</i>	<i>Description</i>
1	126-0815	1	Seed Gate Kit	13:2	121-6082	1	Wheel-Rim
1:1	126-0415	1	Gate-Seed	13:3	5108	1	Valve
1:2	126-0416	6	Spacer	14	32151-48	2	E-Ring
1:3	1-807512	6	Bolt-CARR	15	3256-39	4	Washer-Flat
1:4	114-3778	12	Nut-HF	16	321-3	1	Screw-HH 1/4-20 X 5/8 ●
1:5	3229-2	3	Screw-CARR	17	3229-11	2	Bolt-Carriage 1/4-20 X 5/8
1:6	121-2016	2	Spring-Extension	18	104-8300	4	Nut-Nyloc 5/16-18 Flg
7	121-1907	1	Bracket-Flow, Seed	19	92-0049	2	Key-Machine 3/16 X 3/16 X 1 1/4
8	121-1912	1	Gauge-Flow, Seed	20	121-1961	2	Bearing
9	125-3782-03	1	Mixer	21	66-8010	2	Spacer
10	121-1929	1	Axle-Front ■	22	3229-3	2	Bolt-Carriage 1/4-20 X 1 1/4
11	3230-23	4	Bolt-Carriage 5/16-18 X 3/4 Short Neck	23	233-67	1	Knob
12	105-3838	2	Spacer	24	103995	1	Washer
13	120-3550	2	Wheel ASM	25	104-7201	2	Nut-Nyloc 1/4-20 Flg
13:1	121-6081	1	Tire				

- Use Pro-Lock, Nut Type (P/N 1-840022, .5ml tube) on threads.
- Apply anti-seize compound to axle ends before installing tires.

Belt Drive Assembly

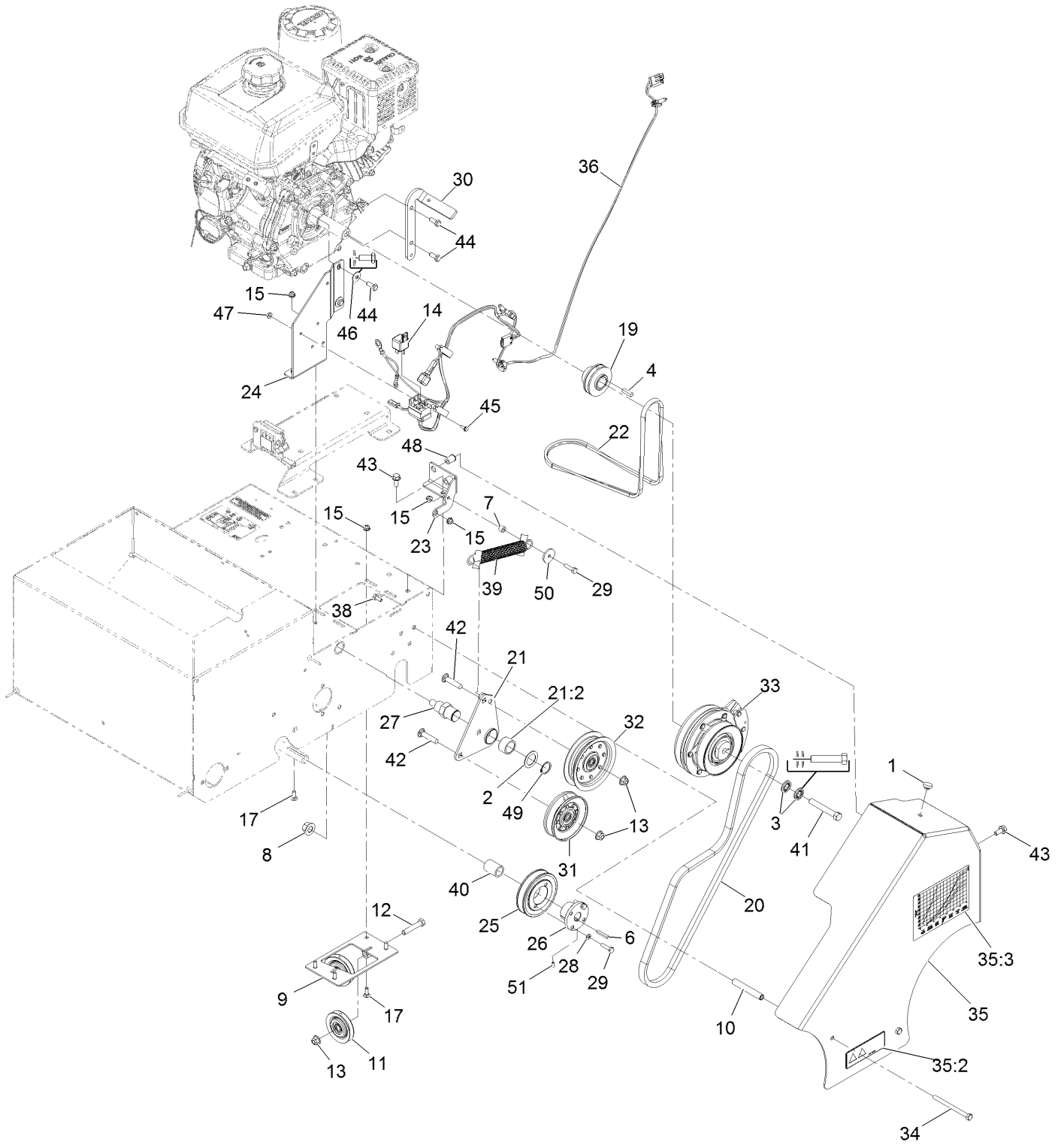

Belt Drive Assembly (continued)

<i>Ref.</i>	<i>Part Number</i>	<i>Qty.</i>	<i>Description</i>	<i>Ref.</i>	<i>Part Number</i>	<i>Qty.</i>	<i>Description</i>
1	1-513658	1	Bumper	28	3253-3	2	Washer-Lock 1/4
2	1-543436	1	Washer-Spacer	29	321-6	3	Screw-HH 1/4-20 X 1
3	1-603610	2	Washer-Spring Disc 7/16	30	135-2030	1	Stop-Clutch
4	1-807259	1	Key-Machine 1/4 X 1/4 X 1	31	116-9623	1	Pulley-Idler V
6	92-0049	1	Key-Machine 3/16 X 3/16 X 1 1/4	32	116-9728	1	Pulley-Idler Flat (4.06-Inch)
7	98-4799	1	Spacer	33	116-9852	1	Clutch-Electric
8	99-5107	1	Nut-Lock 1/2-13	34	322-19	2	Screw-HH 5/16-18 X 4
9	126-0418-03	1	ASM Tension-Pulley	35	135-7597	1	Guard-Belt, W/Decals
10	104-0502	2	Spacer-Kickstand, Long	35:2	93-7321	1	Decal-Danger
11	121-1965	2	Pulley-Idler	35:3	116-8537	1	Decal-Graph, Seed
12	323-10	2	Screw-HH 3/8-16 X 2	36	135-7761	1	Harness-Wire
13	104-8301	4	Nut-Nyloc 3/8-16 Flg	38	321-3	1	Screw-HH 1/4-20 X 5/8
14	105-4145	1	Relay	39	126-0091	1	Spring-Extension
15	104-7201	8	Nut-Nyloc 1/4-20 Flg	40	126-0108	1	Spacer
17	3229-1	6	Bolt-Carriage 1/4-20 X 3/4	41	3212-12	1	Screw-HH 7/16-20 X 3 ●
19	116-9471	1	Pulley-Mule Drive	42	3231-29	2	Bolt-Carriage 3/8-16 X 1 3/4
20	116-9518	1	Belt-Seeder, Clutch	43	3234-47	3	Screw-HH Flg 5/16-18 X 3/4
21	116-9519	1	Idler Arm ASM	44	3235-6	4	Screw-HH 5/16-24 X 3/4
21:2	116-9538	1	Bushing	45	3290-321	1	Screw-HWH
22	116-9532	1	Belt-Mule Drive	46	3290-456	2	Washer-Spring Disc
23	116-9533-01	1	Bracket-Spring	47	32128-17	1	Nut-Flange #10-24 Top Lock
24	135-2029-01	1	Guard-Belt	48	32148-7	2	Nut-Clinch
25	121-2019	1	Sheave-Taper Lock	49	32151-29	1	Ring-Retaining
26	121-2022	1	Bushing-Taper Lock	50	103995	1	Washer
27	116-9539	1	Pivot-Idler	51	126-0284	1	Screw-Set, Hs

● Use Pro-Lock, Nut Type (P/N 1-840022, .5ml tube) on threads.

Transmission Assembly

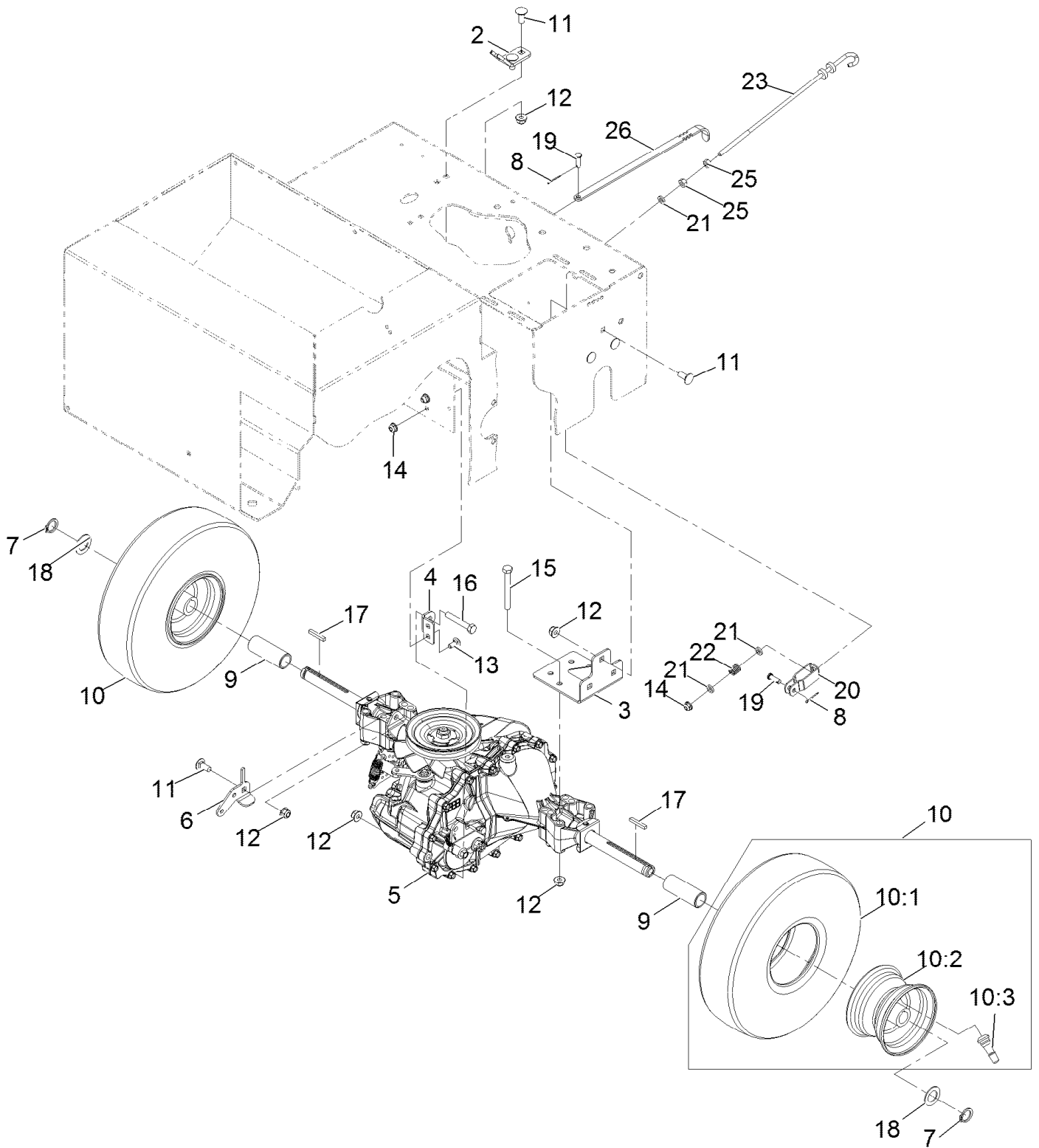

Transmission Assembly (continued)

<i>Ref.</i>	<i>Part Number</i>	<i>Qty.</i>	<i>Description</i>	<i>Ref.</i>	<i>Part Number</i>	<i>Qty.</i>	<i>Description</i>
2	121-1897	1	Bracket-Cable	13	3229-11	2	Bolt-Carriage 1/4-20 X 5/8
3	121-1901-03	2	Bracket-Axle	14	104-7201	3	Nut-Nyloc 1/4-20 Flg
4	121-1904	1	Bracket-Transaxle, Torque	15	322-13	8	Screw-HH 5/16-18 X 2 3/4
5	121-1908	1	Transaxle ASM ●	16	322-10	1	Screw-HH 5/16-18 X 2
6	121-1909	1	Bracket-Transaxle	17	92-0049	2	Key-Machine 3/16 X 3/16 X 1 1/4
7	32120-93	2	Ring-Retaining	18	67-9410	2	Washer
8	3272-4	2	Pin-Cotter	19	1-808265	2	Pin-Clevis 1/4 X 3/4
9	121-1988	2	Spacer	20	39-3080	1	Clevis
10	120-3550	2	Wheel ASM	21	55-9620	3	Spacer
10:1	121-6081	1	Tire	22	63-4220	1	Spring-Compression
10:2	121-6082	1	Wheel-Rim	23	121-2018	1	Rod-Brake
10:3	5108	1	Valve	25	3217-5	2	Nut-Hex 1/4-20
11	3230-23	9	Bolt-Carriage 5/16-18 X 3/4 Short Neck	26	121-2039	1	Lever-Bypass
12	104-8300	18	Nut-Nyloc 5/16-18 Flg				

● Apply anti-seize compound to axle ends before installing tires.

EXMARK ACCESSORIES AND OPTIONS*

MID-MOUNT RIDING ACCESSORIES AND OPTIONS

CUSTOM RIDE SEAT SUSPENSION SYSTEM	OPERATOR CONTROLLED DISCHARGE
FULL SUSPENSION SEAT	SUN SHADE
DECK LIFT ASSIST KIT	TRASH CONTAINER
HITCH KIT	TURF STRIPER
LIGHT KIT	ULTRA VAC COLLECTION SYSTEM
12V POWER PORT	ULTRA VAC QUICK DISPOSAL SYSTEM
MICRO-MULCH SYSTEM	

OUT-FRONT RIDING ACCESSORIES AND OPTIONS

CUSTOM RIDE SEAT SUSPENSION SYSTEM	SNOW BLADE
DUAL-TAIL WHEEL	SNOWBLOWER
FLOOR PAN EXTENDER	SUN SHADE
HITCH KIT	TRASH CONTAINER
LIGHT KIT	ULTRA VAC COLLECTION SYSTEM
MICRO-MULCH SYSTEM	ULTRA VAC QUICK DISPOSAL SYSTEM
ROLL OVER PROTECTION SYSTEM (ROPS)	WEATHER CAB

WALK-BEHIND ACCESSORIES AND OPTIONS

GRASS CATCHER	TURF STRIPER
MICRO-MULCH SYSTEM	STANDON

*Some accessories and options not available for some models.

Place Model No. and Serial No.
Label Here (Included in the Literature
Pack) or Fill in Below

Model No. _____

Serial No. _____

Date Purchased _____

Engine Model No. and Spec. No. _____

Engine Serial No. (E/No) _____

© 2019 Exmark Mfg. Co., Inc.
2101 Ashland Ave
Beatrice, NE 68310
All Rights Reserved

Part No. 4504-684 Rev. A
(402) 223-6375
Fax (402) 223-5489
Printed in the USA.

