



# LAZER Z<sup>®</sup> E-SERIES

Model No. LZE751GKA604C1—Serial No. 406294345 and Up

Picture below may not reflect actual product.



# Parts Manual

Part No. 4504-625 Rev. B

# Ordering Replacement Parts

To order replacement parts, please supply the part number, the quantity, and the description of each part desired.

## Understanding Reference Numbers

Each identified part in an illustration has a reference number. The reference number for a part also appears in the parts list, along with other information about the part.

This catalog uses two special reference number formats, one to indicate parts in a service assembly and another to indicate the quantity of a given part in an illustration.

## Service Assembly Reference Numbers

Parts in service assemblies have reference numbers in the form a:b. The a represents the reference number of the entire service assembly and the b represents a sequential number unique to each part within the service assembly.

For example, a wheel assembly might be identified by reference number 6, the tire by 6:1, the valve by 6:2, and the wheel by 6:3. When you order the assembly identified by reference number 6, you receive all parts identified by reference numbers 6:1, 6:2, and 6:3. However, you may also order any part individually. Reference numbers of this type appear in illustration and in parts lists.

## Reference Numbers Indicating Quantity

In an illustration, if a reference number indicates more than one part, the reference number has the form nX y. The n represents the quantity of the part, the X is the multiplication symbol, and the y represents the reference number.

For example, in an illustration, the reference number 2X 37 means that two of the parts identified by reference number 37 are indicated.

# Touch Up Paint

Exmark black touch up spray paint – gloss black.

Exmark red touch up paint (spray paint – P/N 1-850337 - .6 oz liquid bottle – P/N 103-9140).



If your Exmark dealer does not have the Exmark part in stock, Exmark will get the parts to the dealer the next business day or the part will be FREE Guaranteed!! (Some restrictions apply. See your participating Exmark Dealer for details.)

## Contents

Complete Deck Assembly . . . . .	4
Deck Assembly . . . . .	6
Deck W/Decals Assembly No. 116-4232 . . . . .	8
Idler Assembly . . . . .	10
Main Frame Assembly . . . . .	12
E-Series Decal . . . . .	14
Full Suspension Assembly . . . . .	16
Roll-Over Protection System . . . . .	18
Roll-Over Protection System Assembly . . . . .	20
Front Caster and Fork Assembly . . . . .	22
Caster Wheel and Fork Assembly . . . . .	24
Decklift Assembly . . . . .	26
Height-of-Cut Assembly No. 109-7438 . . . . .	28
Console Assembly . . . . .	30
Motion Control Assembly . . . . .	32
Rear Wheel Assembly . . . . .	34
Park Brake Assembly . . . . .	36
Suspension Seat Assembly . . . . .	38
Seat W/Tracks Assembly No. 126-5801 . . . . .	40
Fuel System Assembly . . . . .	42
Fuel Tank Assembly . . . . .	44
Engine Assembly . . . . .	46
Hydraulic Assembly . . . . .	48
LH Hydro Assembly No. 135-7903 . . . . .	50
RH Hydro Assembly No. 135-7904 . . . . .	52
Pump Idler Assembly No. 116-1255 . . . . .	54
Electrical Assembly . . . . .	56

# Complete Deck Assembly

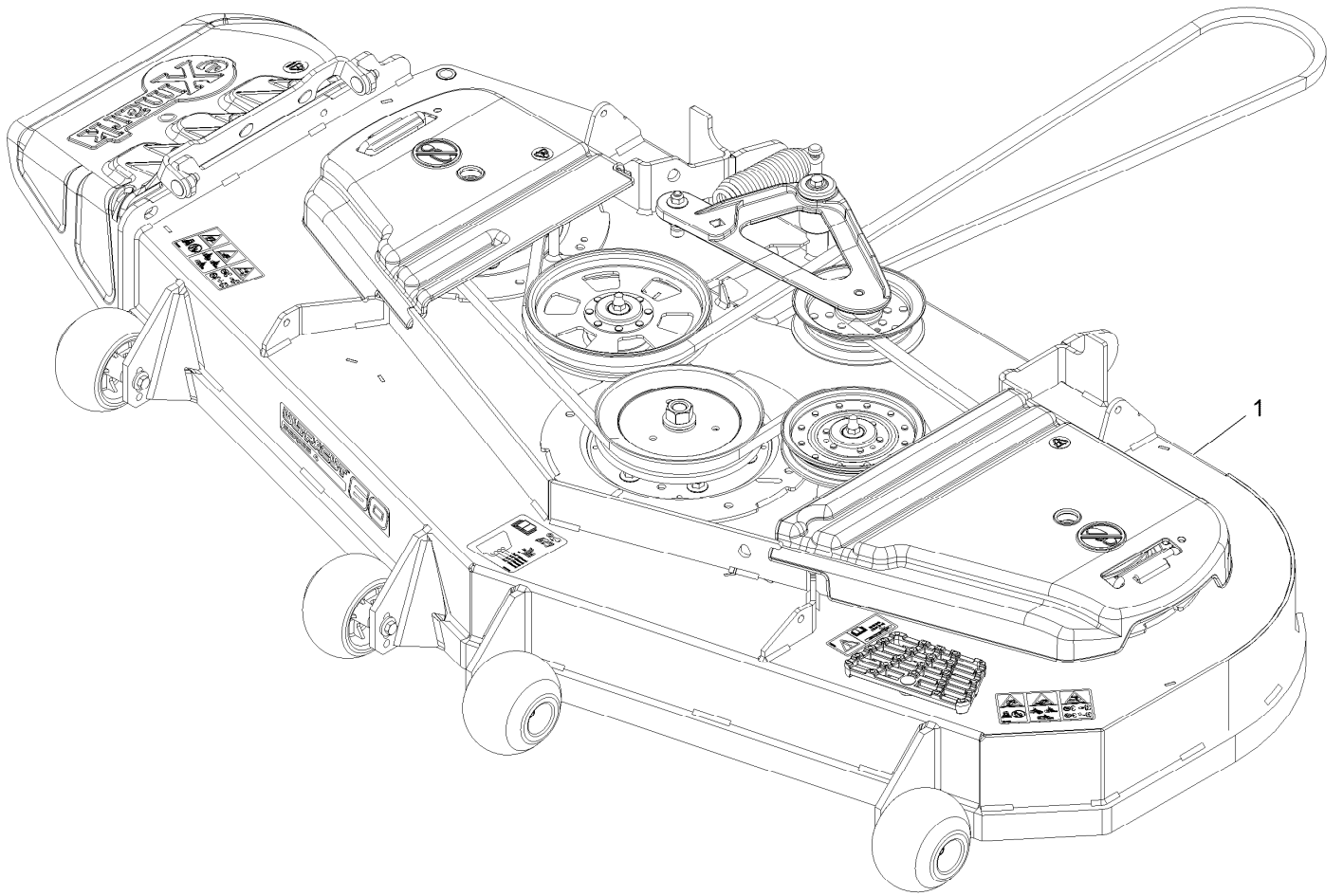

# Complete Deck Assembly (continued)

<i>Ref.</i>	<i>Part Number</i>	<i>Qty.</i>	<i>Description</i>
1	116-3599	1	ASM,604 Deck Complete

# Deck Assembly

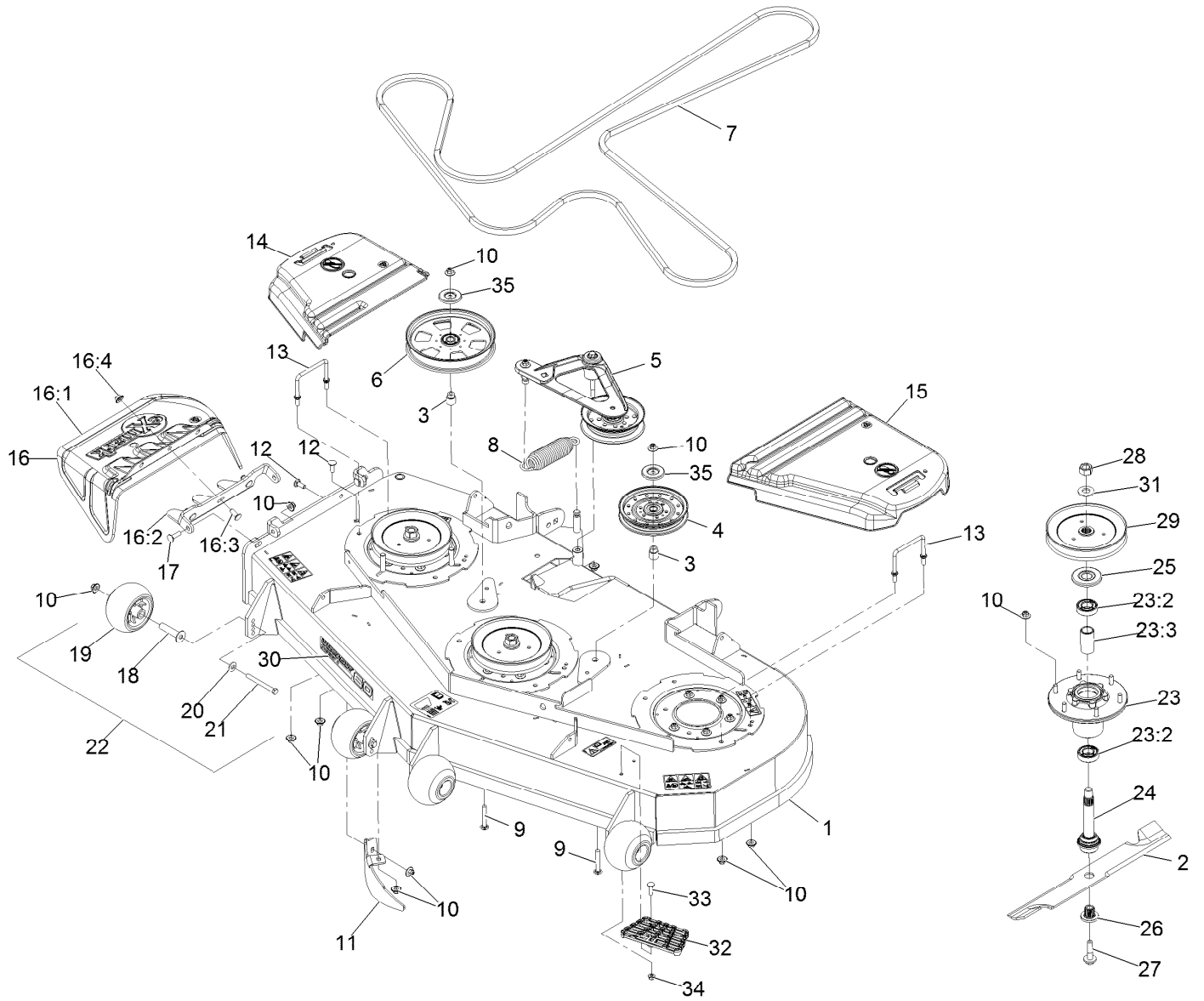

## Deck Assembly (continued)

<i>Ref.</i>	<i>Part Number</i>	<i>Qty.</i>	<i>Description</i>	<i>Ref.</i>	<i>Part Number</i>	<i>Qty.</i>	<i>Description</i>
1	116-4232	1	Deck ASM,W/Decals 60	18	116-8131	4	Axle, Roller
2	103-6383	3	Blade, Solid ●	19	103-8415	4	Roller-Anti-Scalp
2	103-6388	3	Blade, Low Lift ●	20	98-5975	4	Washer-Spring Disc 3/8
2	103-6393	3	Blade, Mulching ◆	21	116-9362	4	Screw-HH 3/8-16 X 3 3/4 GR 8
2	103-6403	3	Blade, Notched	22	116-9981	3	Kit, Anti-Scalp Roller
2	116-5174	3	Blade-Extreme 2, 20.50" ●	23	116-3344	3	ASM-Cutter Hsg With Bearings
3	1-633456	2	Bushing, Idler	23:2	116-0720	2	Bearing-Ball
4	126-7685	1	Idler-Pulley	23:3	116-3312	1	Spacer-Bearing
5	116-3755	1	Deck Idler ASM	24	116-3341	3	ASM-Spindle And Seal
6	116-9639	1	Pulley-Idler, Flat	25	116-1286	3	Guard,Bearing Top .989
7	135-5774	1	Belt,V-5V-198.75	26	103-3037	3	Bushing, Splined
8	116-6317	1	Spring-Extension	27	109-9220	3	Screw-Sems 1/2-20 X 2.19 ■ □
9	3231-44	2	Bolt-Carriage 3/8-16 X 2 1/2	28	116-7306	3	Nut-Hex ▲
10	109-6658	32	Nut-Nyloc 3/8-16 Flg	29	116-0676	3	Sheave,Blade Drive 7.25
11	116-5614-01	1	Dogleg - Lz60	30	126-6589	1	Decal, 604
12	3231-22	2	Bolt-Carriage 3/8-16 X 1	31	103-2802	3	Washer-Spring Disc 3/4
13	109-6982	2	Wireform-Cover	32	126-4781-03	1	Step-Deck
14	116-0094	1	Cover-Belt, RH	33	3230-3	1	Bolt-Carriage 5/16-18 X 1 1/4
15	109-6938	1	Cover-Belt, LH	34	104-8300	1	Nut-Nyloc 5/16-18 Flg
16	109-7188	1	ASM,Discharge Chute	35	126-8043	2	Shield-Dust
16:1	109-2738	1	Chute, Discharge				
16:2	109-8675-01	1	Bracket,Discharge Chute				
16:3	3231-22	3	Bolt-Carriage 3/8-16 X 1				
16:4	109-6658	3	Nut-Nyloc 3/8-16 Flg				
17	3231-28	2	Bolt-Carriage 3/8-16 X 1 1/4				

● Optional Equipment

▲ Torque to 130-160 ft-lb

◆ Requires installation of mulch kit for proper mulching. See your Exmark dealer for details.

□ Apply lubricant to threads as needed to prevent seizing. Copper based anti-seize preferable. Grease is an acceptable substitute.

■ Torque to 50-60 ft-lb

# Deck W/Decals Assembly No. 116-4232





## Deck W/Decals Assembly No. 116-4232 (continued)

<i>Ref.</i>	<i>Part Number</i>	<i>Qty.</i>	<i>Description</i>	<i>Ref.</i>	<i>Part Number</i>	<i>Qty.</i>	<i>Description</i>
3	126-6464	2	Decal-Danger Thrown Objects	8	116-3755	1	Deck Idler ASM
4	109-6036	1	Decal-Roller, Anti-Scalp	9	126-4781-03	1	Step-Deck
5	112-9028	2	Decal-Cover, Missing	10	3230-3	1	Bolt-Carriage 5/16-18 X 1 1/4
6	116-8283	1	Decal-Torque, Bolt	11	104-8300	1	Nut-Nyloc 5/16-18 Flg
7	116-8727	1	Decal-Belt Routing				

# Idler Assembly



## Idler Assembly (continued)

<i>Ref.</i>	<i>Part Number</i>	<i>Qty.</i>	<i>Description</i>	<i>Ref.</i>	<i>Part Number</i>	<i>Qty.</i>	<i>Description</i>
1	43-0940	1	Spacer	9	126-0423	1	Pin-Spring, Anchor
2	103-2916	1	Guard-Top	10	109-6658	2	Nut-Flange, NI
3	103-3504	2	Bearing-Spherical	11	109-7409	1	Screw-Shoulder, HH
4	103-3505	1	Seal-Lip, Double	12	323-8	1	Screw-HH
5	103-3506	1	Seal-Lip, Single	13	32120-10	2	Ring-Snap
6	126-9196	1	Idler-Pulley, Flat	14	302-19	1	Fitting-Grease
7	106-7159	2	O-Ring	15	126-9195	1	Shield-Guard, Dust

# Main Frame Assembly

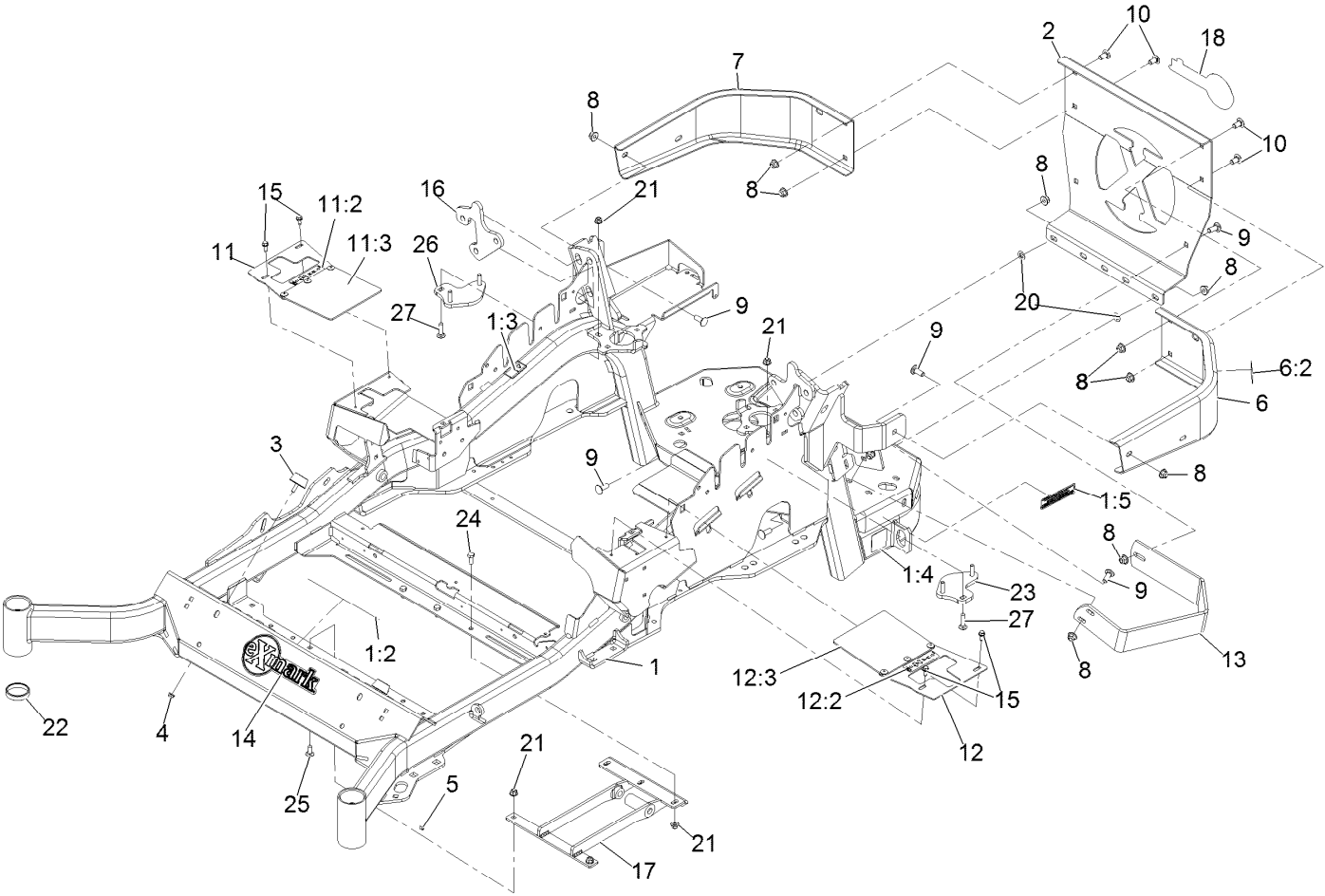

## Main Frame Assembly (continued)

<i>Ref.</i>	<i>Part Number</i>	<i>Qty.</i>	<i>Description</i>	<i>Ref.</i>	<i>Part Number</i>	<i>Qty.</i>	<i>Description</i>
1	116-5902	1	Mainframe ASM	12	131-4610	1	LH Motion Control Cover ASM
1:2	132-0871	1	Decal-Danger	12:2	99-8936	1	Decal-Control, Motion
1:3	106-5517	2	Decal-Warning	12:3	136-8967	1	Flap-Rubber
1:4	106-2655	2	Decal-Hazard, Pinched Finger	13	126-2067-03	1	Guard-Muffler
1:5	133-8062	1	Decal-Arrestor, Spark	14	135-2274	1	Decal-Exmark
2	109-8863-03	1	Plate,Rear Guard	15	32144-10	4	Screw-HWH 1/4-20 X .62
3	131-8834	2	Bumper	16	136-1674-01	2	Plate-Mount, Shock
4	104-7201	2	Nut-Nyloc 1/4-20 Flg	17	131-6327-01	1	Mount-Lower
5	1-811010	2	Plug	18	126-6877	1	Decal, Exmark Logo
6	116-0180	1	LH Bumper ASM	20	107-3154	2	Nut-Push 3/8-16
6:2	106-5517	1	Decal-Warning	21	104-8300	7	Nut-Nyloc 5/16-18 Flg
7	116-0057-03	1	Bumper-RH	22	1-543508	4	Cup-Bearing Tapered Roller
8	104-8301	11	Nut-Nyloc 3/8-16 Flg	23	127-6766	1	LH Plate ASM (W/Studs)
9	3231-22	7	Bolt-Carriage 3/8-16 X 1	24	322-3	3	Screw-HH 5/16-18 X 3/4
10	3231-21	4	Bolt-Carriage 3/8-16 X 3/4	25	3230-23	2	Bolt-Carriage 5/16-18 X 3/4 Short Neck
11	131-4615	1	RH Motion Control Cover ASM	26	127-6765	1	RH Plate ASM (W/Studs)
11:2	99-8936	1	Decal-Control, Motion	27	3230-3	2	Bolt-Carriage 5/16-18 X 1 1/4
11:3	136-8967	1	Flap-Rubber				

# E-Series Decal



## E-Series Decal (continued)

<i>Ref.</i>	<i>Part Number</i>	<i>Qty.</i>	<i>Description</i>
1	126-6571	2	Decal-E-Series

# Full Suspension Assembly

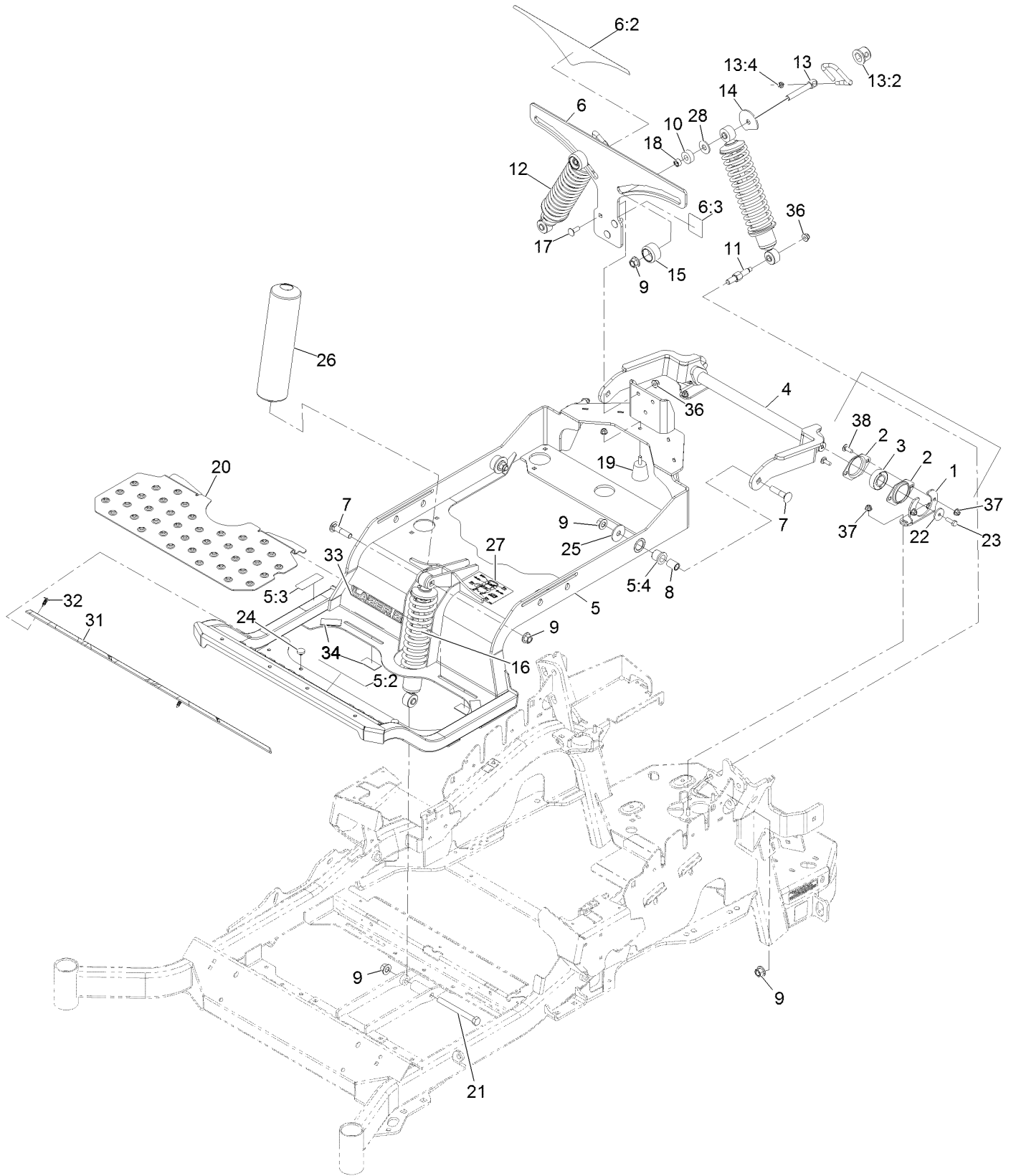



## Full Suspension Assembly (continued)

<i>Ref.</i>	<i>Part Number</i>	<i>Qty.</i>	<i>Description</i>	<i>Ref.</i>	<i>Part Number</i>	<i>Qty.</i>	<i>Description</i>
1	127-6759-03	2	Bracket-Bearing	16	136-1719	1	Shock ASM-Front
2	127-6743	4	Housing-Bearing, Flange	16	136-8993	1	Shock/Spring ASM
3	1-653346	2	Bearing	17	3231-22	3	Bolt-Carriage 3/8-16 X 1
4	127-6754-03	1	Arm-Trailing	18	47-7270	2	Bearing-Needle
5	132-5057	1	Subframe ASM	19	132-5058	1	Bumper-Rubber
5:2	132-0871	1	Decal-Danger	20	132-5089-01	1	Floorpan
5:3	115-9625	1	Decal-Brake, Parking	21	325-19	1	Screw-HH 1/2-13 X 5
5:4	127-6745	2	Bushing-Flange	22	105-3048	2	Washer-Flat
6	133-1809	1	Bracket-Mounting	23	116-0648	2	Screw-HH 5/16-18 X 1 W/Patch
6:2	132-5080	1	Decal-Adjustment, Ride	24	1-513658	2	Bumper
6:3	132-5063	1	Decal-Lock, Cam	25	86-1990	2	Washer
7	127-6768	3	Bolt-Carriage 1/2-13 X 2 1/4	26	133-1803	1	Cover-Shock
8	127-6751	2	Spacer-Aluminum	27	114-4465	1	Decal-Service Aid
9	99-5107	8	Nut-Lock 1/2-13	28	3256-6	2	Washer
10	131-8801	2	Spacer	31	133-1812	1	Floor Mat
11	131-6348	2	Bolt-Shoulder	32	117-2382	2	Plug-Plastic
12	133-1815	2	Shock/Spring ASM	33	133-1804	1	Decal-Lazer Logo
13	131-8843	2	Cam Lock ASM	34	130-0733	4	Pad-Rubber
13:2	107-1644	1	Cap-Lock	36	104-8301	5	Nut-Nyloc 3/8-16 Flg
13:4	119-4038	1	Nut-Hex Nyloc 5/16-18	37	104-8300	9	Nut-Nyloc 5/16-18 Flg
14	131-4646	2	Plate-Stop	38	3230-10	4	Bolt-Carriage 5/16-18 X 7/8
15	131-4647	2	Knob-Front				

# Roll-Over Protection System

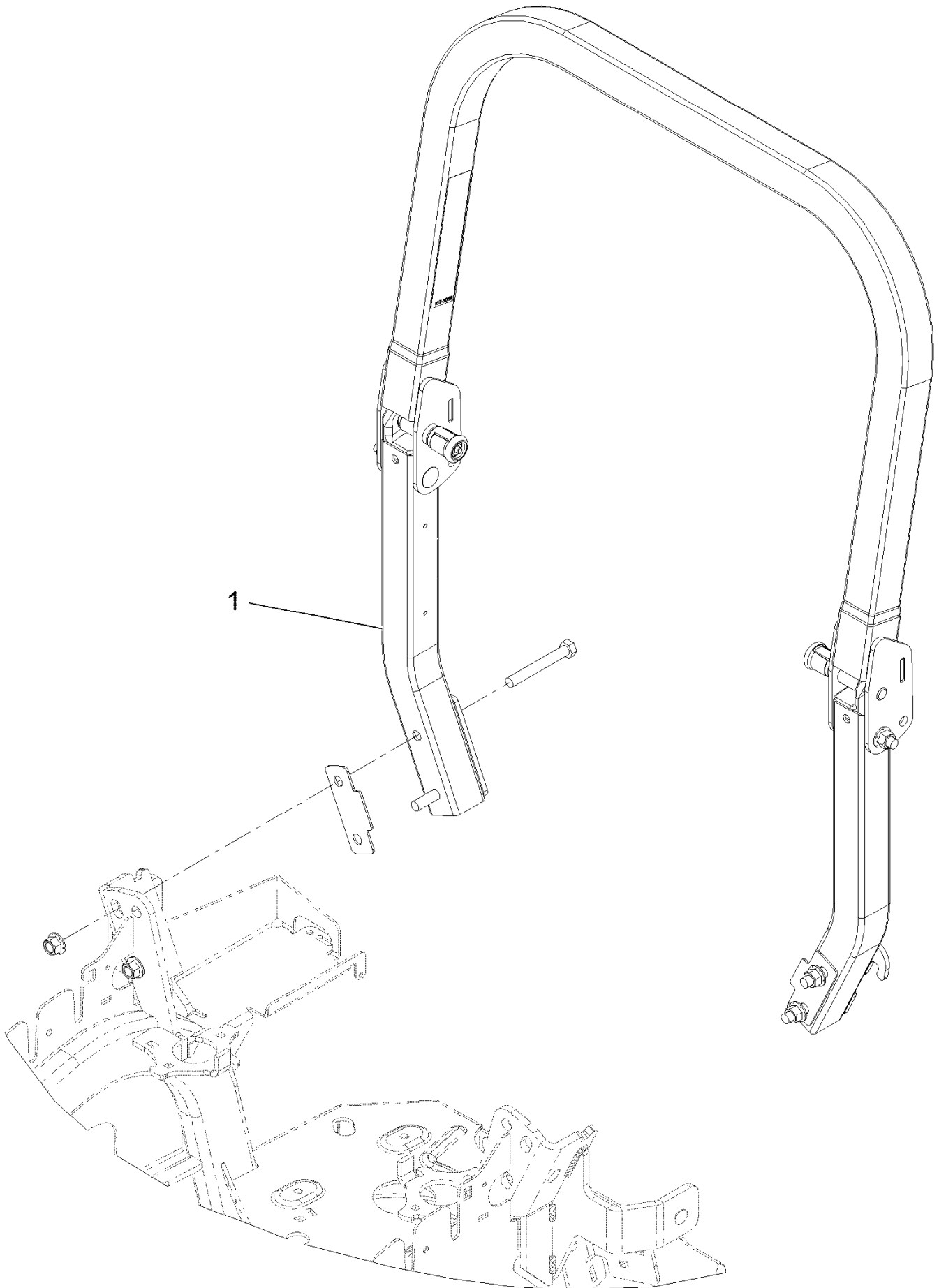

# Roll-Over Protection System (continued)

<i>Ref.</i>	<i>Part Number</i>	<i>Qty.</i>	<i>Description</i>
1	116-2882	1	ROPS ASM

# Roll-Over Protection System Assembly

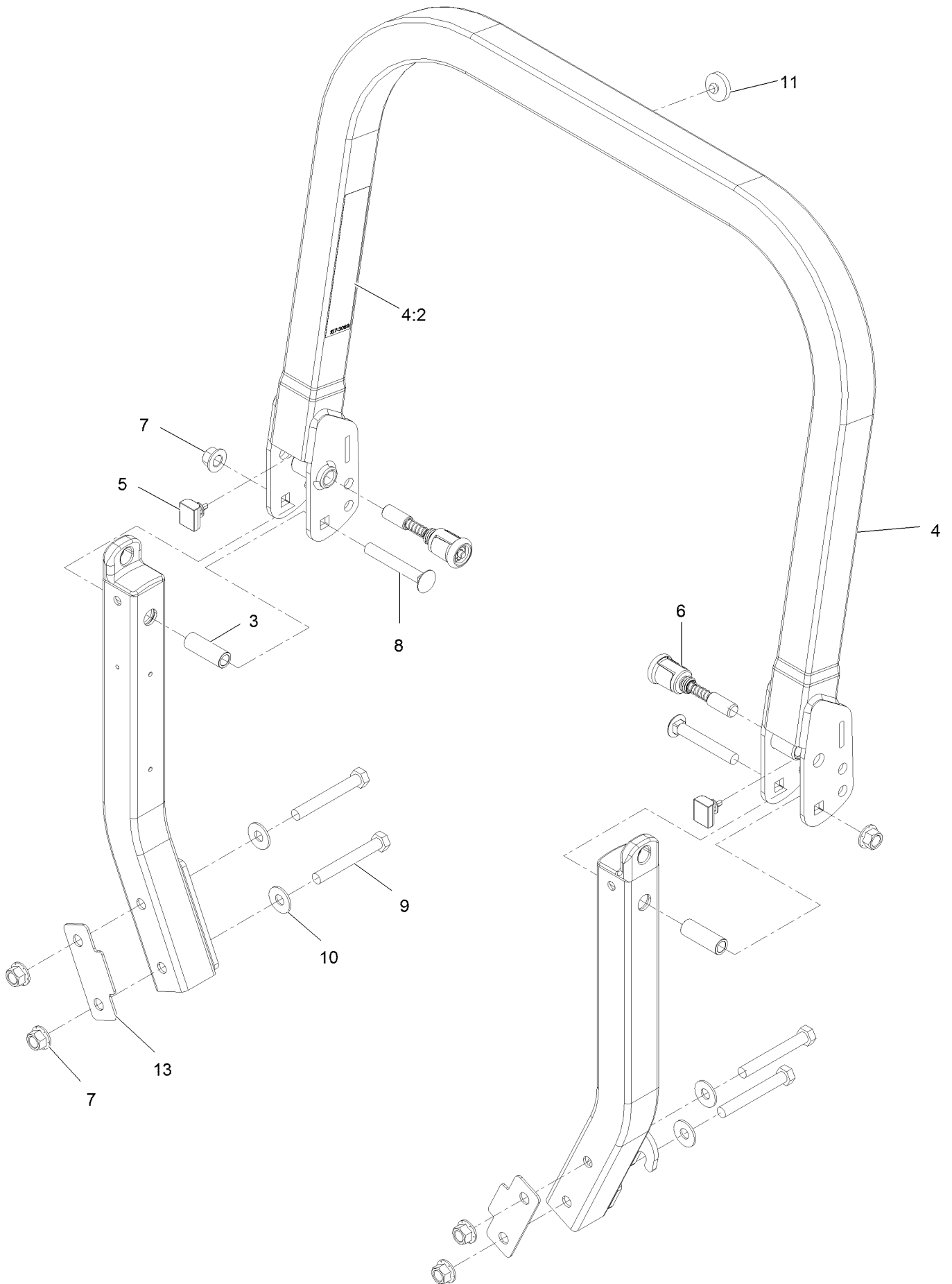

## Roll-Over Protection System Assembly (continued)

<i>Ref.</i>	<i>Part Number</i>	<i>Qty.</i>	<i>Description</i>	<i>Ref.</i>	<i>Part Number</i>	<i>Qty.</i>	<i>Description</i>
3	109-6653	2	Spacer	8	3233-10	2	Bolt-Carriage 1/2-13 X 3 1/2
4	116-0019	1	Upper ROPS ASM	9	325-35	4	Screw-HH
4:2	107-3069	1	Decal-Warning	10	109-9505	4	Washer, Spring Disc 1/2
5	109-5337	2	Bumper-ROPS	11	109-9233	1	Bumper-Push-In, Rubber
6	116-0104	2	Pin-Spring	13	116-0960	2	Spacer
7	99-5107	8	Nut-Lock 1/2-13				



# Front Caster and Fork Assembly (continued)

<i>Ref.</i>	<i>Part Number</i>	<i>Qty.</i>	<i>Description</i>
1		2	Front Caster W/Fork ASM ●

● Not serviced separately

# Caster Wheel and Fork Assembly

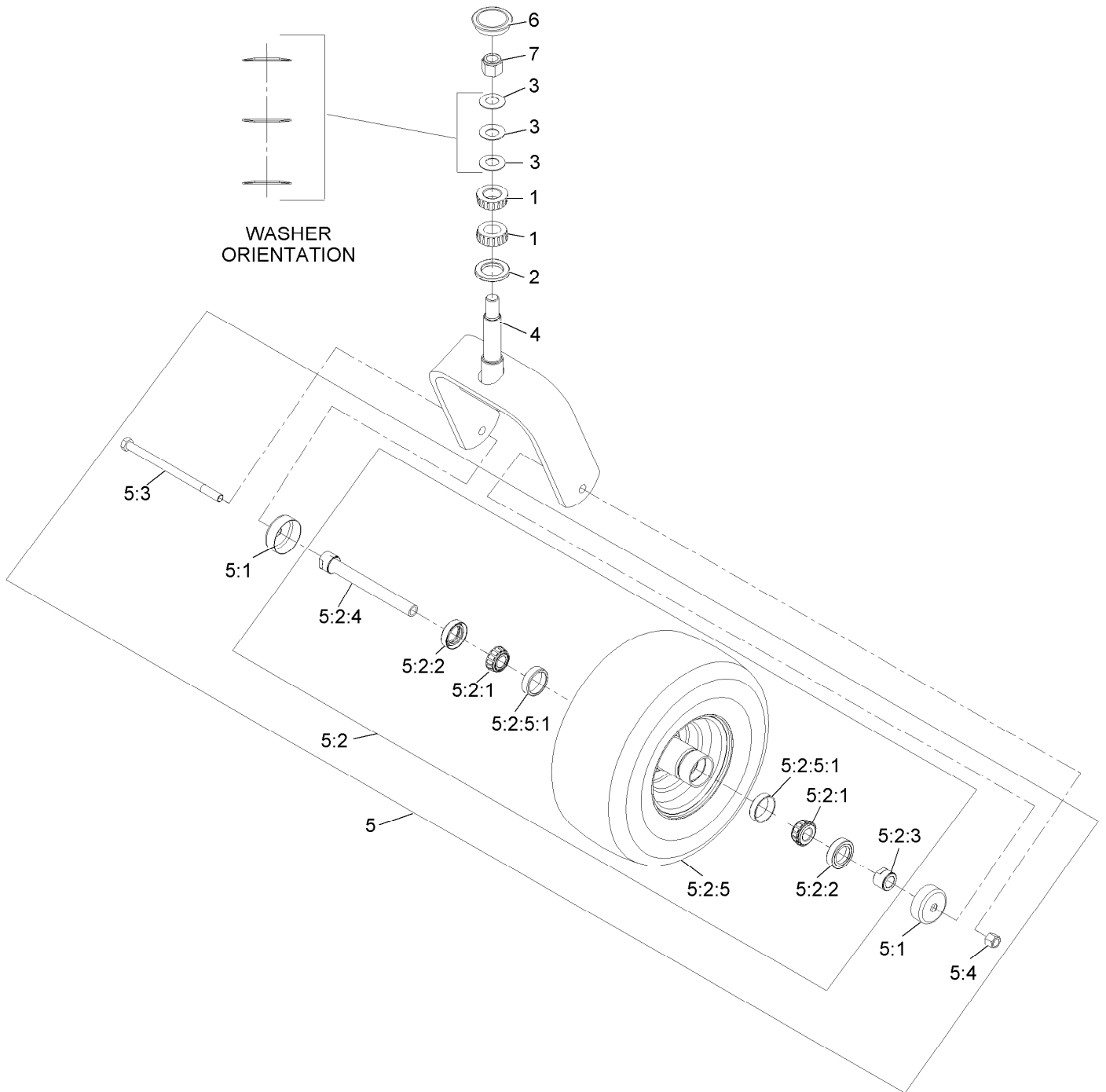



## Caster Wheel and Fork Assembly (continued)

<i>Ref.</i>	<i>Part Number</i>	<i>Qty.</i>	<i>Description</i>	<i>Ref.</i>	<i>Part Number</i>	<i>Qty.</i>	<i>Description</i>
1	1-543509	2	Bearing-Roller, Tapered	5:2:3	103-3051	1	Spacer-Nut ■
2	116-5647	1	Seal-Grease	5:2:4	126-5361	1	Axle Caster ASM
3	1-633508	3	Washer-Bellville	5:2:5		1	Wheel And Tire ASM ●
4	116-6707-01	1	Caster	5:2:5:1	1-633584	2	Bearing-Cup
5	109-9127	1	Wheel & Tire ASM	5:3	325-39	1	Screw-HH
5:1	103-2768	2	Guard-Seal	5:4	3296-23	1	Nut-Lock, NI
5:2		1	Wheel And Tire ASM ●	6	103-4882	1	Cap-Grease
5:2:1	1-633585	2	Bearing-Cone, Taper	7	3296-51	1	Nut-Lock, NI
5:2:2	103-0063	2	Seal-Caster				

● Not serviced separately

■ Use Pro-Lock, Nut Type (P/N 1-840022, .5ml tube) on threads.

# Decklift Assembly

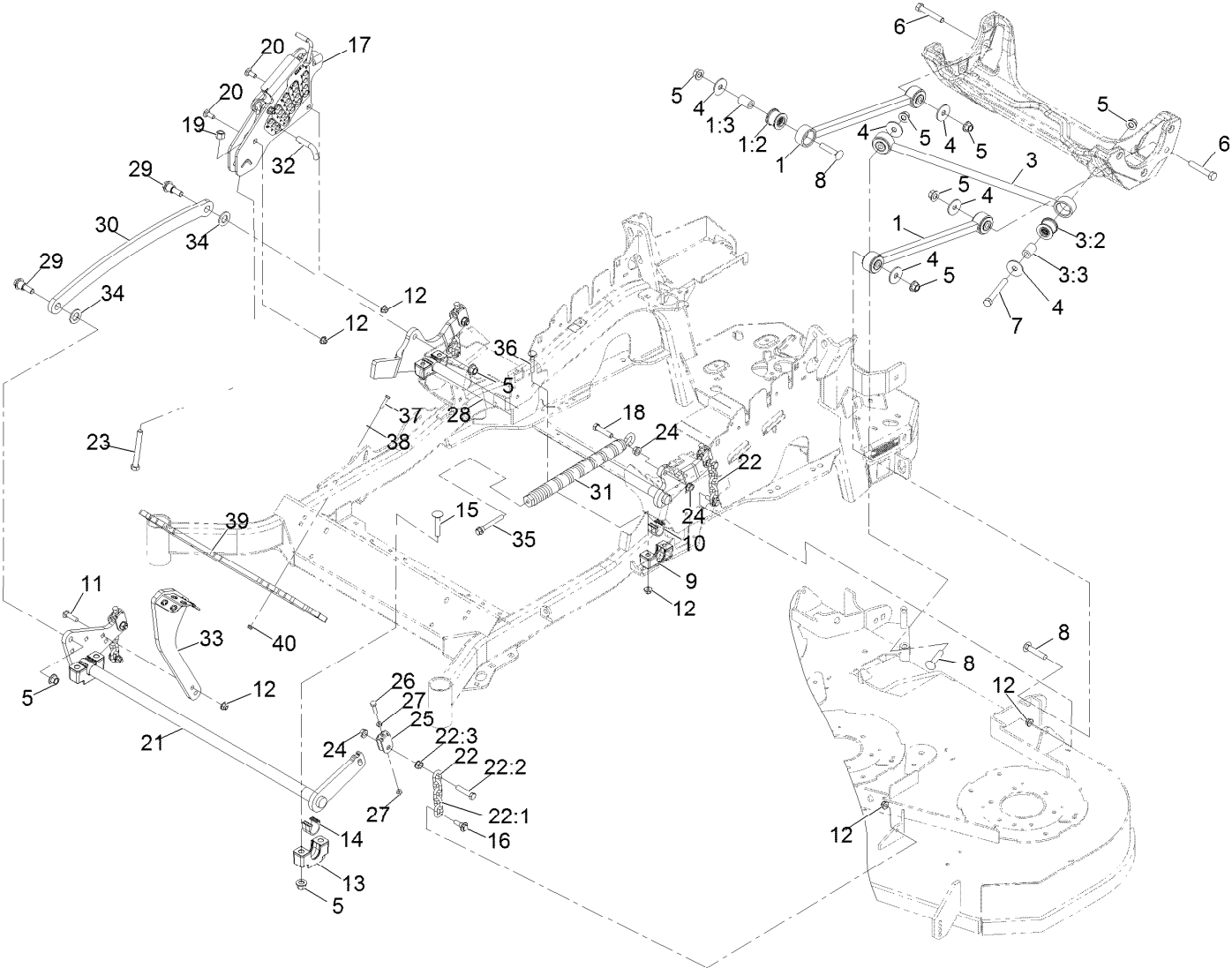

## Decklift Assembly (continued)

<i>Ref.</i>	<i>Part Number</i>	<i>Qty.</i>	<i>Description</i>	<i>Ref.</i>	<i>Part Number</i>	<i>Qty.</i>	<i>Description</i>
1	116-2031	2	Long Strut ASM	19	3296-23	1	Nut-Nyloc 1/2-13
1:2	109-5009	2	Bushing-Suspension, Rubber	20	3231-2	2	Bolt-Carriage 3/8-16 X 1
1:3	109-5010	2	Spacer	21	126-2475-03	1	Decklift-Front
3	109-5013	1	Panhard Rod ASM	22	116-0756	4	Deck Lift Chain ASM
3:2	109-5009	2	Bushing-Suspension, Rubber	22:1	1-633447	1	Chain-Lift, Deck
3:3	109-5010	2	Spacer	22:2	109-9065	1	Screw-HH 7/16-14 X 2
4	86-1990	6	Washer	22:3	32128-37	1	Nut-Whizlock 7/16-14
5	99-5107	12	Nut-Lock 1/2-13	23	116-0559	1	Bolt-HH 1/2-13 X 4 Tap
6	325-12	2	Screw-HH 1/2-13 X 3	24	32128-37	6	Nut-Whizlock 7/16-14
7	325-17	1	Screw-HH 1/2-13 X 4	25	109-9066	4	Yoke-Adjust, Deck
8	3233-34	3	Bolt-Carriage 1/2-13 X 2 1/2	26	322-47	4	Screw-HH 5/16-18 X 1 1/4
9	127-0553	2	Support-Bearing, Cross Shaft (Rear)	27	3218-2	8	Nut-Jam 5/16-18
10	109-7173	2	Bearing-Cross Shaft, Rear	28	116-0459-03	1	Lift-Deck, Rear
11	3231-4	2	Bolt-Carriage 3/8-16 X 1 1/2	29	116-0780	2	Screw-Shoulder HHF 1/2-13 X 1.12
12	104-8301	12	Nut-Nyloc 3/8-16 Flg	30	116-0797-03	1	Link-Lift, Deck
13	109-9409	2	Support-Bearing, Cross Shaft (Front)	31	116-0000	1	Spring-Extension
14	109-9410	2	Bearing-Cross Shaft, Front	32	116-5584	1	Pin-HOC
15	116-1700	4	Bolt-Carriage 1/2-13 X 2 1/2 Spl Neck	33	131-8812-01	1	Lever-Foot
16	109-9840	4	Screw-Hex Flange 3/8-16 X .80	34	3256-28	2	Washer-3/4 SAE
17	109-7438	1	HOC ASM	35	92-7674	1	Screw-Shcs 3/8-16 X 2.212
18	109-9065	1	Screw-HH 7/16-14 X 2	36	3231-7	4	Bolt-Carriage 3/8-16 X 2 1/4
				37	321-8	4	Screw-HH 1/4-20 X 1 1/4
				38	3256-22	4	Washer-1/4 SAE
				39	140-4963-01	1	Weight-Toe Board
				40	104-7201	4	Nut-Nyloc 1/4-20 Flg

# Height-of-Cut Assembly No. 109-7438

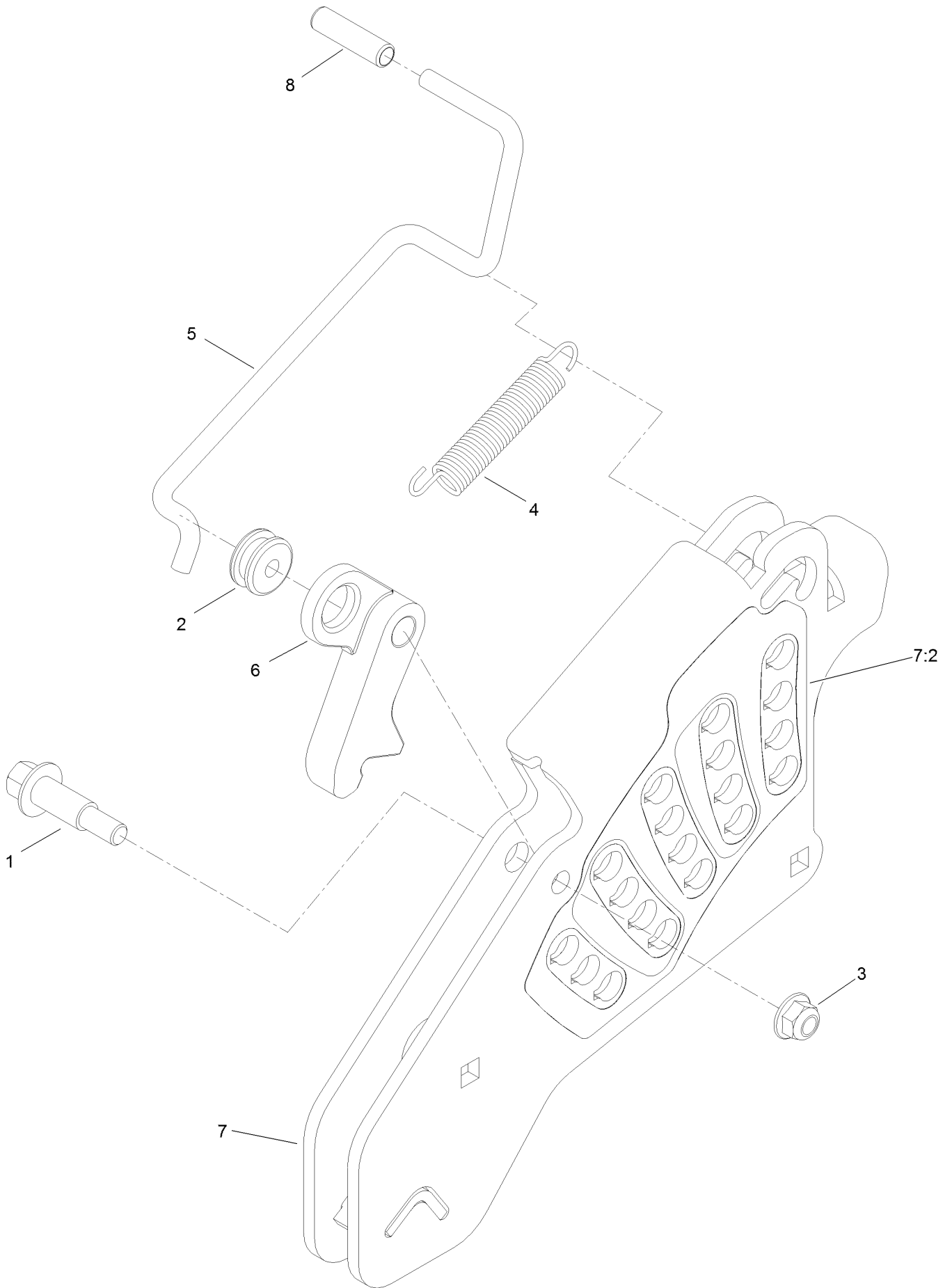

# Height-of-Cut Assembly No. 109-7438 (continued)

<i>Ref.</i>	<i>Part Number</i>	<i>Qty.</i>	<i>Description</i>	<i>Ref.</i>	<i>Part Number</i>	<i>Qty.</i>	<i>Description</i>
1	62-1330	1	Bolt-Shoulder	6	116-0118	1	Pawl-Transport, HOC
2	109-7130	1	Grommet	7	109-7335	1	HOC Plate ASM
3	104-8301	1	Nut-HF, NI	7:2	126-4398	1	Decal-HOC
4	109-7124	1	Spring-Extension	8	109-8250	1	Grip-Lever
5	109-7128	1	Rod-Lock, Transport				

# Console Assembly

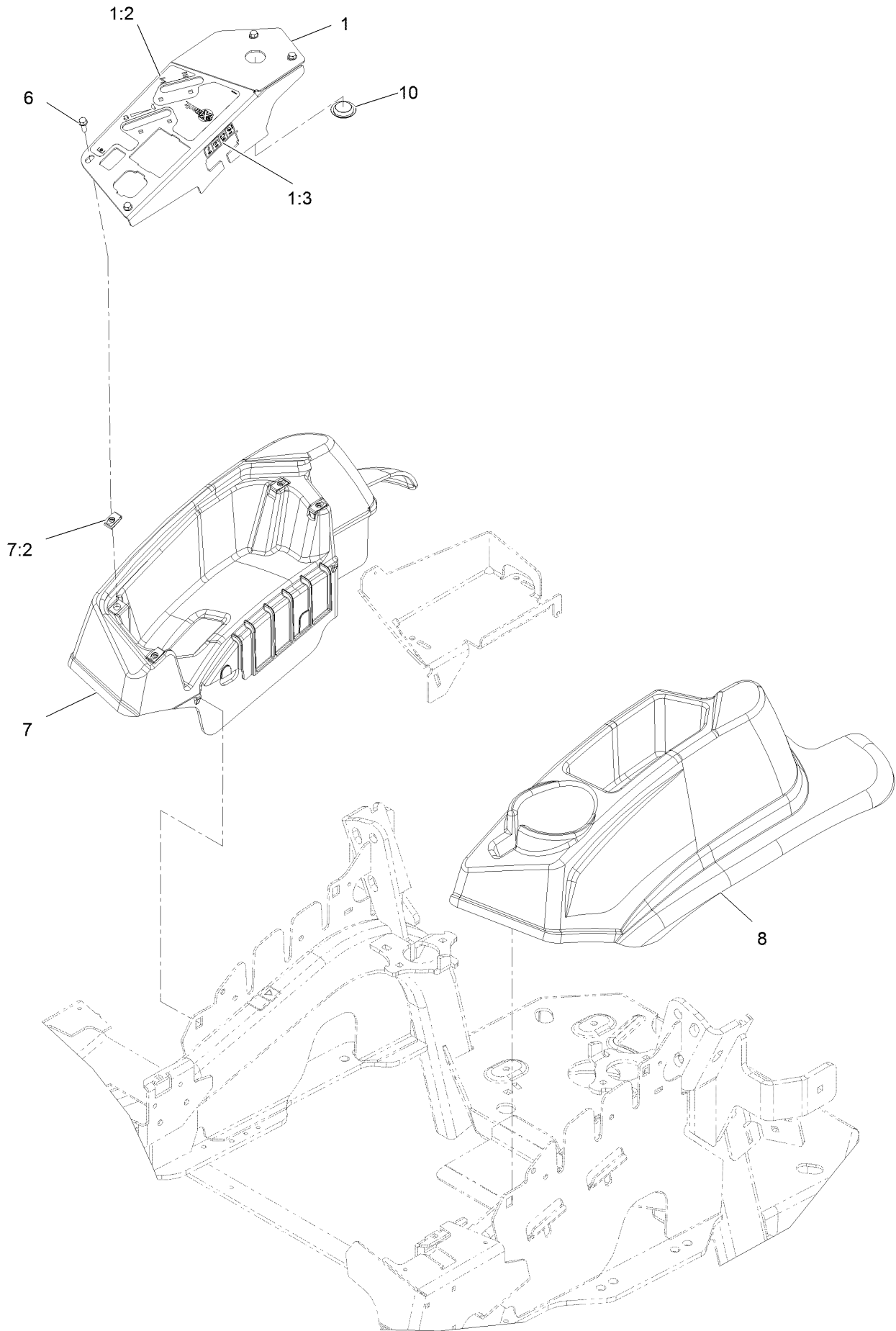

## Console Assembly (continued)

<i>Ref.</i>	<i>Part Number</i>	<i>Qty.</i>	<i>Description</i>	<i>Ref.</i>	<i>Part Number</i>	<i>Qty.</i>	<i>Description</i>
1	109-8484	1	Console,Panel W/Decal	7	116-1278	1	Console,RH As ASM
1:2	116-8724	1	Decal-Control Panel Non-EFI	7:2	107069	4	Nut-Retainer-Panel 1/4-20
1:3	114-4466	1	Decal-Fuses	8	109-9457	1	Console, LH As
6	32105-15	4	Screw-Machine 1/4-20 X 3/4	10	116-1875	1	Plug-Plastic

# Motion Control Assembly

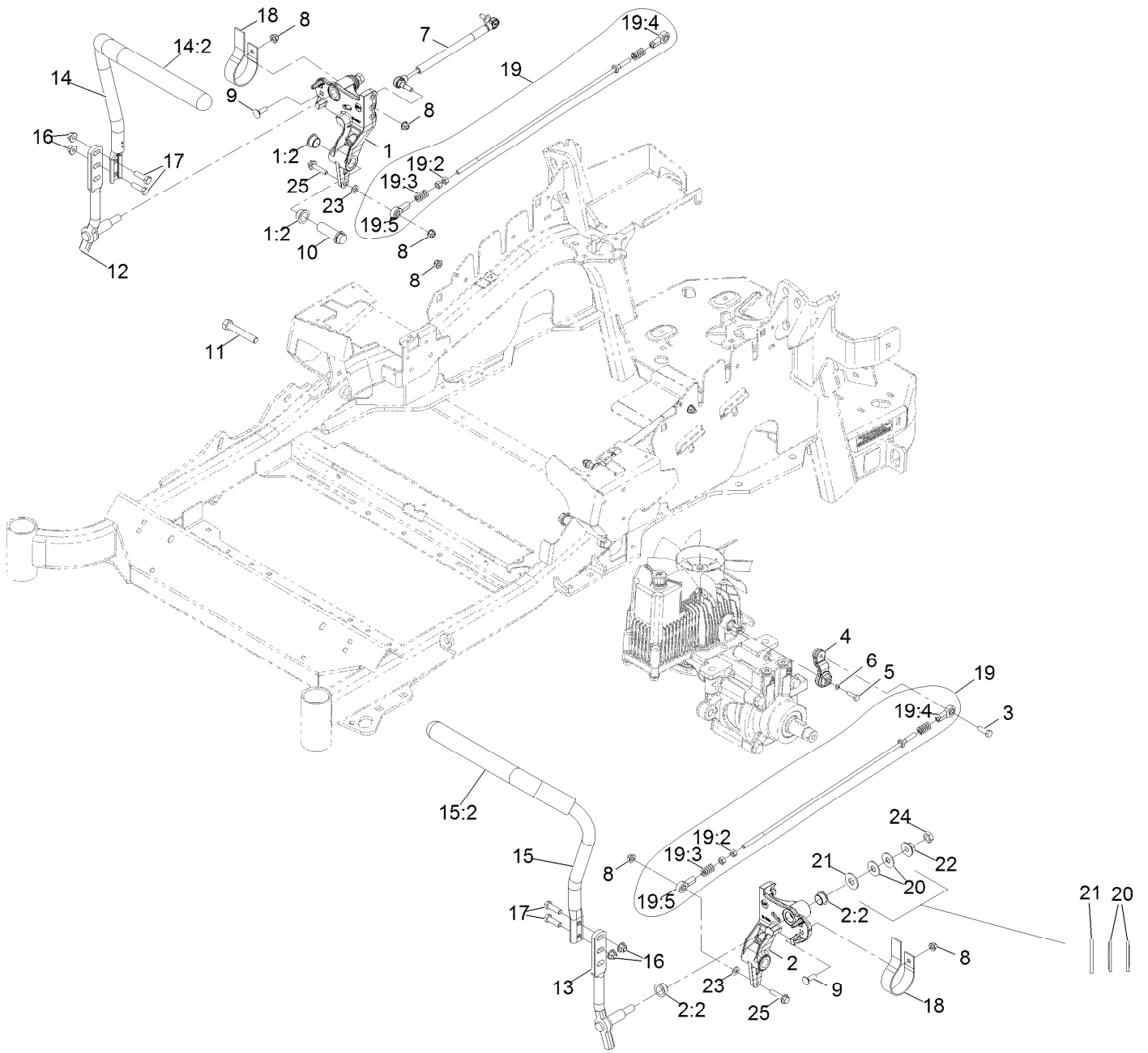



## Motion Control Assembly (continued)

<i>Ref.</i>	<i>Part Number</i>	<i>Qty.</i>	<i>Description</i>	<i>Ref.</i>	<i>Part Number</i>	<i>Qty.</i>	<i>Description</i>
1	116-0880	1	RH Motion Control And Bushing ASM	14:2	109-5668	1	Grip-Lever, Control
1:2	109-8054	4	Bushing-Flanged	15	135-4476	1	ASM-Handle-LH
2	116-0881	1	LH Motion Control And Bushing ASM	15:2	109-5668	1	Grip-Lever, Control
2:2	109-8054	4	Bushing-Flanged	16	104-8301	4	Nut-Nyloc 3/8-16 Flg
3	116-0648	2	Screw-HH 5/16-18 X 1 W/Patch ●	17	323-7	4	Screw-HH 3/8-16 X 1 1/4
4	109-4581	2	Arm-Control, Pump	18	109-5575	2	Spring-Leaf
5	9080046	2	Screw-HH 1/4-20 X 7/8 ●	19	109-8107	2	Pump Linkage Rear ASM
6	1-303435	2	Washer-Spring Disc 1/4	19:2	3219-2	2	Nut-Hex 5/16-24
7	116-0027	2	Damper-Control, Motion	19:3	1-323245	2	Spring-Compression
8	104-8300	8	Nut-Nyloc 5/16-18 Flg	19:4	1-633152	1	Balljoint
9	3230-2	2	Bolt-Carriage 5/16-18 X 1	19:5	1-543017	1	Balljoint
10	109-5891	2	Hub-Threaded	20	109-9505	4	Washer, Spring Disc 1/2
11	325-12	2	Screw-HH 1/2-13 X 3	21	3256-6	2	Washer
12	116-0039	1	Lever-Control Motion, RH	22	32128-56	2	Nut-Hex 1/2-13 Flange
13	116-0040	1	Lever-Control Motion, LH	23	3256-23	2	Washer-5/16 SAE
14	135-4727	1	Handle- RH W/Grip	24	3218-5	2	Nut-Jam 1/2-13
				25	115-1794	2	Screw-Hex Flange 5/16-18 X 1 1/2

● Use Pro-Lock, Nut Type (P/N 1-840022, .5ml tube) on threads.

# Rear Wheel Assembly

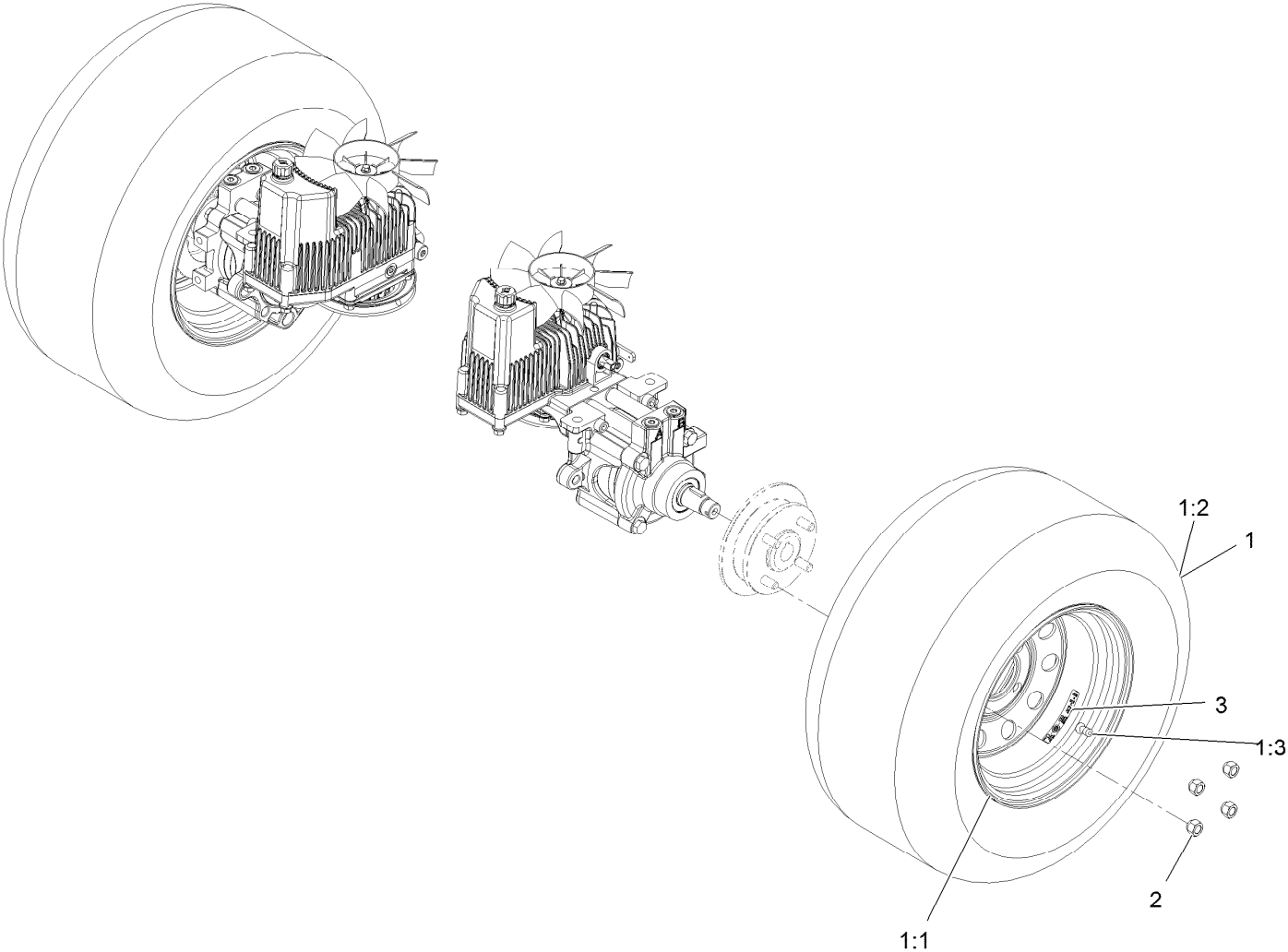

## Rear Wheel Assembly (continued)

<i>Ref.</i>	<i>Part Number</i>	<i>Qty.</i>	<i>Description</i>	<i>Ref.</i>	<i>Part Number</i>	<i>Qty.</i>	<i>Description</i>
1	116-8294	2	ASM-Wheel And Tire	2	242-50	8	Nut-Lug 1/2-20
1:1	116-8295	1	ASM-Rim 60	3	126-2055	2	Decal-Torque, Wheel Hub Lug
1:2	116-8296	1	Tire-Drive				
1:3	232-27	1	Stem-Valve				

# Park Brake Assembly

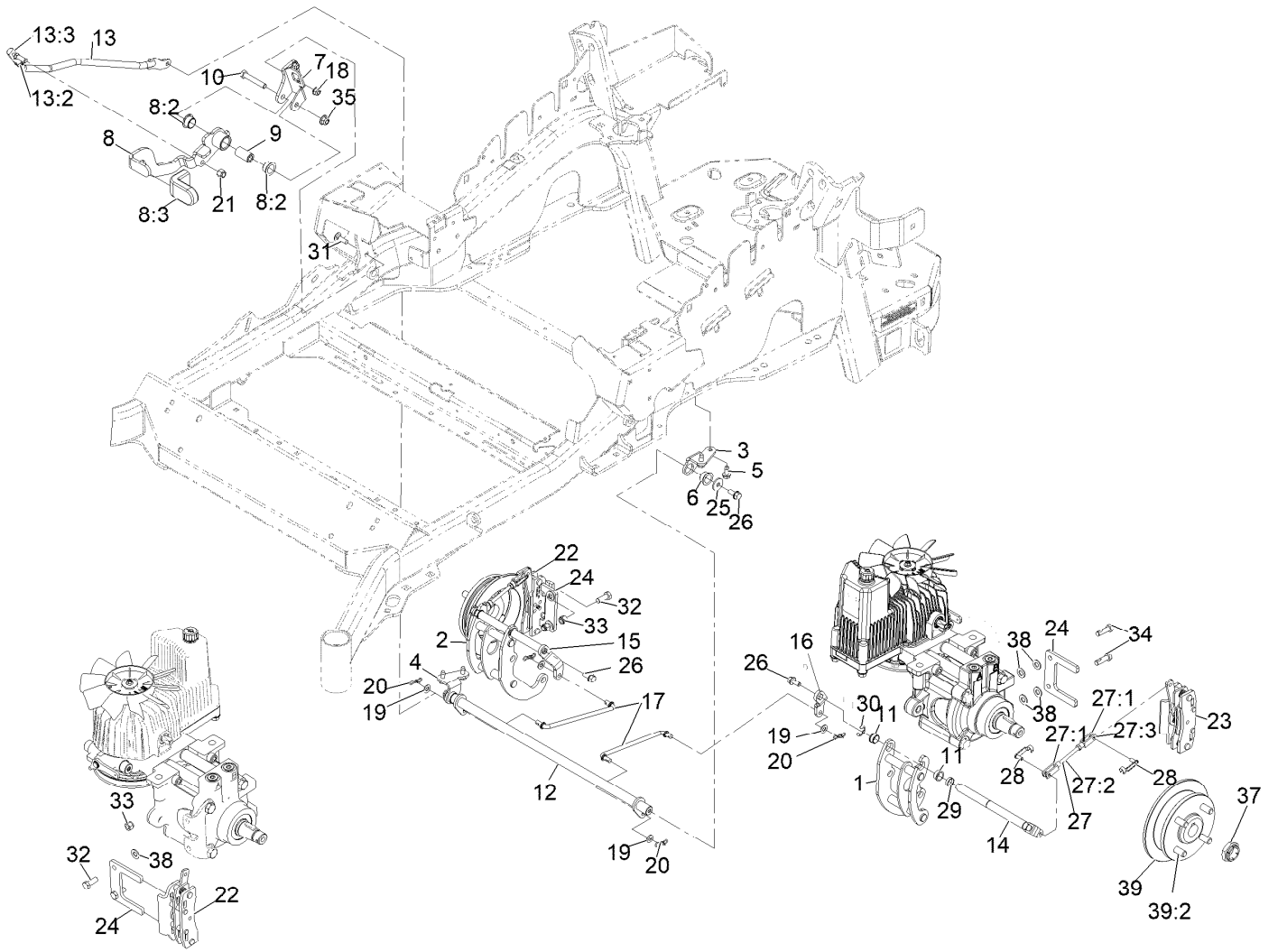

## Park Brake Assembly (continued)

<i>Ref.</i>	<i>Part Number</i>	<i>Qty.</i>	<i>Description</i>	<i>Ref.</i>	<i>Part Number</i>	<i>Qty.</i>	<i>Description</i>
1	126-4248	1	Mount-Bellcrank, LH	20	119-1415	4	Pin-Cotter, Locking
2	126-4249	1	Mount-Bellcrank, RH	21	3296-6	1	Nut-Nyloc 3/8-24
3	116-9681	1	Mount-Pivot, LH	22	135-7440	1	Caliper-Brake, RH
4	116-9682	1	Mount-Pivot, RH	23	135-7441	1	Caliper-Brake, LH
5	32144-70	4	Screw-HWH 5/16-18 X 3/4 Tf	24	135-7828	2	Plate-Mount, Brake
6	109-8054	2	Bushing-Flanged	25	115-7109	2	Washer-Flat
7	116-9096-01	1	Bracket-Mount	26	98-9940	4	Screw-HHF
8	135-7982	1	Brake Lever ASM W/Grip M-R	27	126-7587	2	Rear Linkage ASM
8:2	109-8054	2	Bushing-Flanged	27:1	126-7588	2	Yoke
8:3	132-4749	1	Grip-Lever	27:2	116-9069	1	Linkage, Rear
9	116-9117	1	Pivot-Handle, Brake	27:3	3220-1	1	Nut-Jam 1/4-28
10	323-11	1	Screw-HH 3/8-16 X 2 1/4	28	126-6395	4	Pin-Clevis, Spring
11	126-6199	4	Bushing	29	126-6200	2	Spacer
12	135-7800	1	Shaft-Cross	30	32120-19	2	E-Ring
13	135-7805	1	ASM, Front Linkage	31	3230-2	2	Bolt-Carriage 5/16-18 X 1
13:2	94-7572	1	End-Tie Rod, RH	32	135-7915	2	Screw-HH,
13:3	3220-3	1	Nut-Jam 3/8-24	33	112-0236	2	Nut-Lock
14	126-4251	2	Bellcrank	34	135-7890	2	Screw-HH, Patch,
15	126-3716	1	Arm-Inner, RH	35	104-8301	1	Nut-Nyloc 3/8-16 Flg
16	126-3715	1	Arm-Inner, LH	37	116-1399	2	Locknut
17	135-7584	2	Wireform, Mid-Link, Lwb	38	3256-24	6	Washer-3/8 SAE
18	104-8300	2	Nut-Nyloc 5/16-18 Flg	39	142-2701	2	Wheel Hub ASM
19	3256-23	4	Washer-5/16 SAE	39:2	116-1696	4	Stud-Wheel

# Suspension Seat Assembly

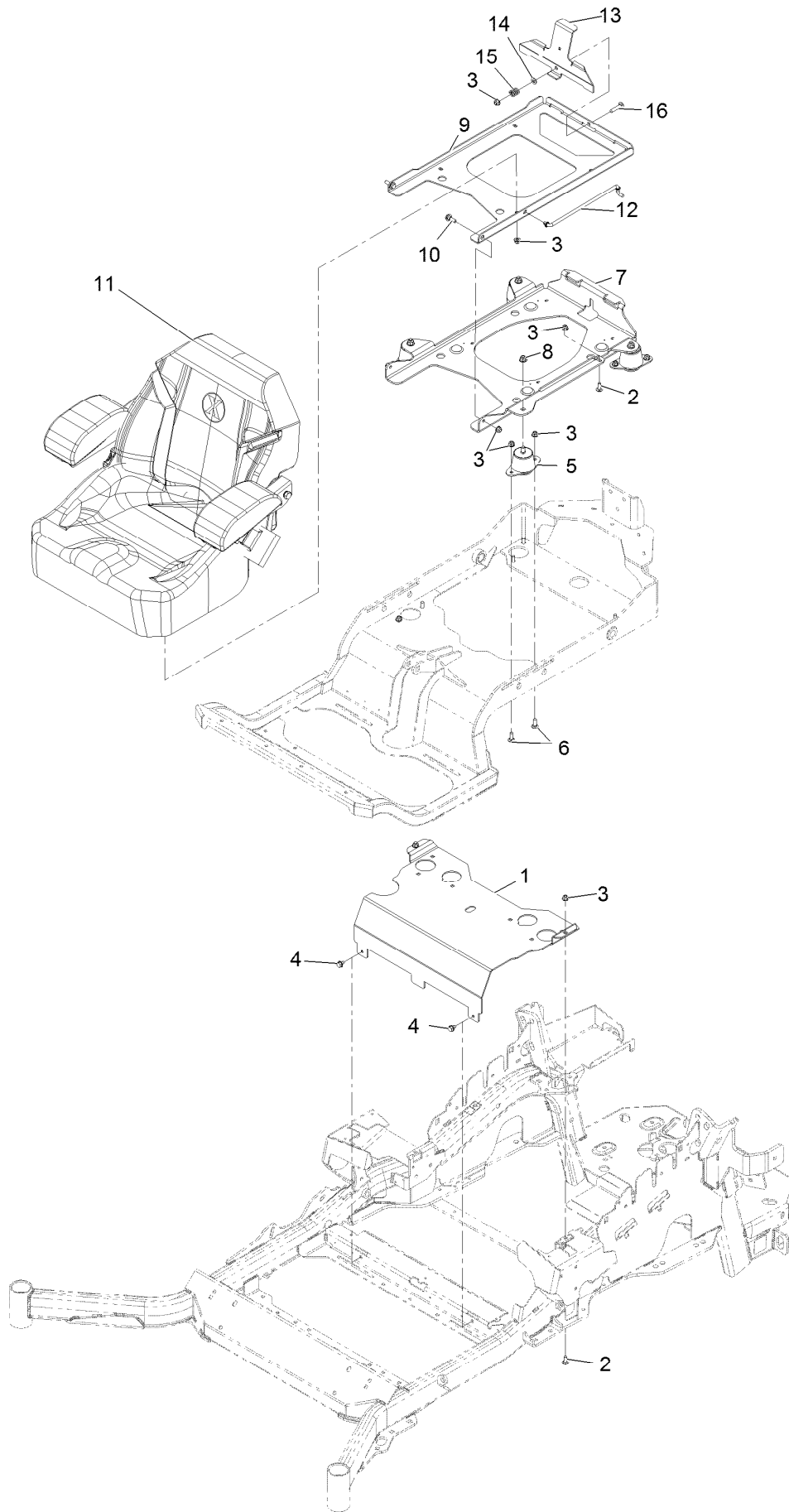

## Suspension Seat Assembly (continued)

<i>Ref.</i>	<i>Part Number</i>	<i>Qty.</i>	<i>Description</i>	<i>Ref.</i>	<i>Part Number</i>	<i>Qty.</i>	<i>Description</i>
1	116-2130-03	1	Panel-Front, Seat Mount	9	116-3859-03	1	Plate-Frame, Seat
2	3230-23	3	Bolt-Carriage 5/16-18 X 3/4 Short Neck	10	116-1297	2	Screw-Shoulder
3	104-8300	18	Nut-Nyloc 5/16-18 Flg	11	126-5801	1	Seat-Exmark Standard
4	9266934	2	Screw-HWH 5/16 X 1/2 Tf	12	116-0070	1	Rod-Prop
5	109-9034	4	Isolator-Seat	13	132-5088-03	1	Plate-Latch, Seat
6	3230-10	8	Bolt-Carriage 5/16-18 X 7/8	14	3256-23	1	Washer-5/16 SAE
7	131-6324-03	1	Plate-Support, ISO Seat	15	107-3017	1	Spring-Compression
8	104-8301	4	Nut-Nyloc 3/8-16 Flg	16	3230-4	1	Bolt-Carriage 5/16-18 X 1 1/2

# Seat W/Tracks Assembly No. 126-5801

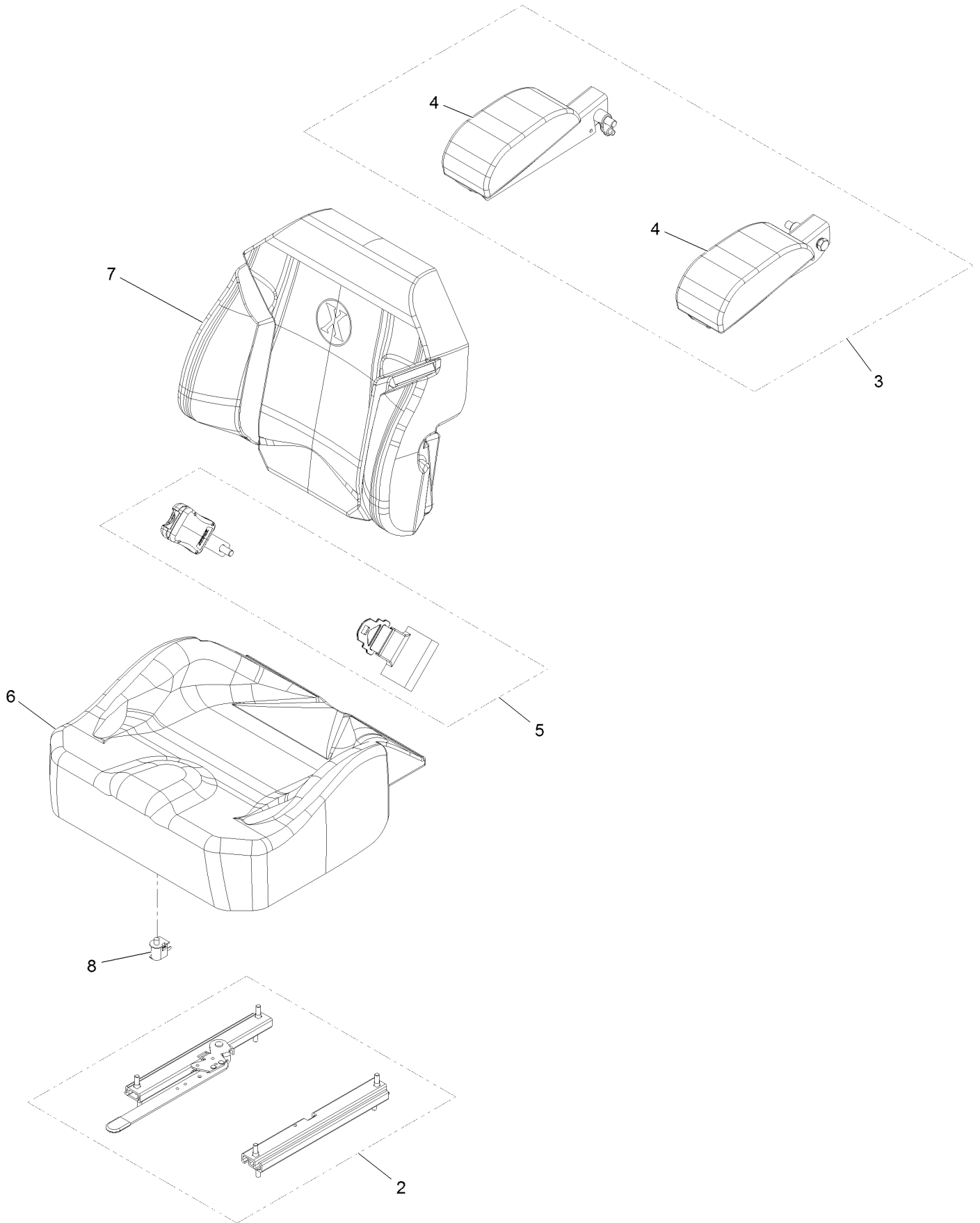



## Seat W/Tracks Assembly No. 126-5801 (continued)

<i>Ref.</i>	<i>Part Number</i>	<i>Qty.</i>	<i>Description</i>	<i>Ref.</i>	<i>Part Number</i>	<i>Qty.</i>	<i>Description</i>
2	109-9801	1	Seat Track Set	6	126-6052	1	Seat Cushion Cover
3	116-8906	1	Kit-Arm Rest Set	7	126-6051	1	Seat Back Cover
4	116-8905	1	Kit-Arm Rest Pads	8	82-2190	1	Switch
5	109-9805	1	Seat Belt Kit				

# Fuel System Assembly

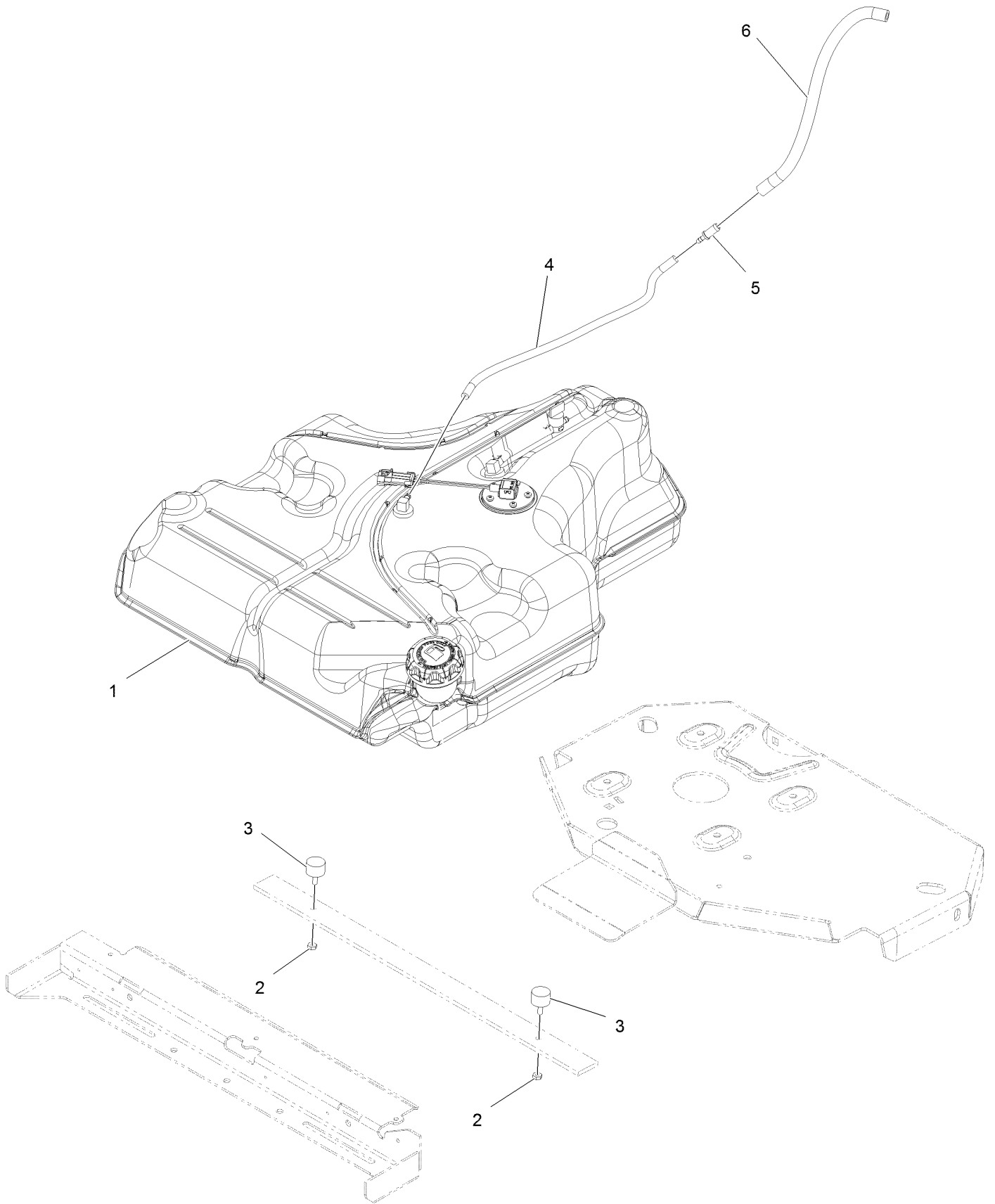

## Fuel System Assembly (continued)

<i>Ref.</i>	<i>Part Number</i>	<i>Qty.</i>	<i>Description</i>	<i>Ref.</i>	<i>Part Number</i>	<i>Qty.</i>	<i>Description</i>
1	135-0645	1	Fuel Tank ASM	4	110-8751	1	Hose-Fuel
2	3218-1	2	Nut-Jam 1/4-20	5	98-2952	1	Fitting-Straight
3	1-523420	2	Bumper	6	116-4344	1	Hose-Fuel

# Fuel Tank Assembly

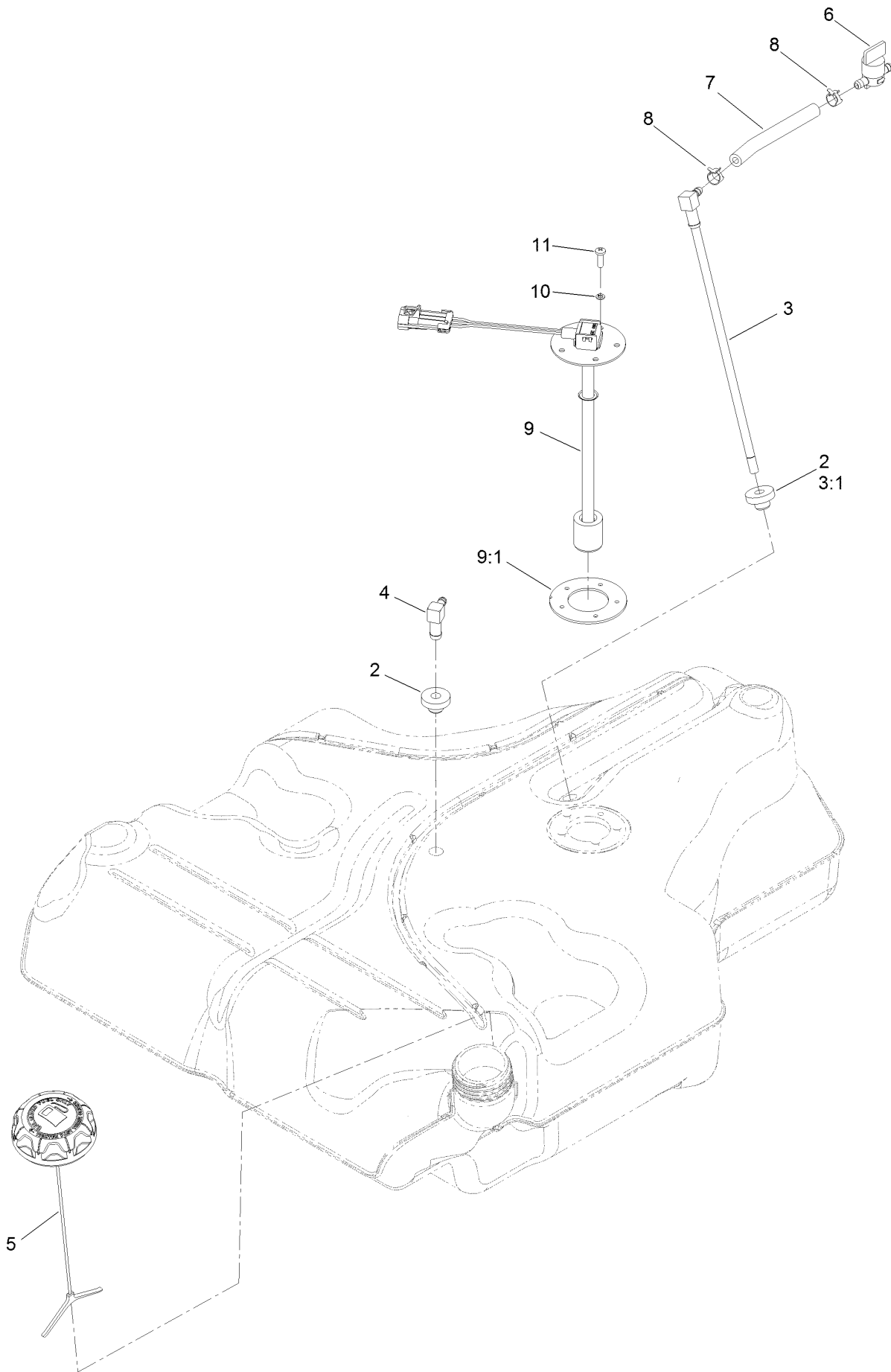

## Fuel Tank Assembly (continued)

<i>Ref.</i>	<i>Part Number</i>	<i>Qty.</i>	<i>Description</i>	<i>Ref.</i>	<i>Part Number</i>	<i>Qty.</i>	<i>Description</i>
2	46-6560	2	Bushing	7	109-0650	1	Hose-Fuel
3	116-2459	1	Fuel Line Kit (With Grommet)	8	2412-98	2	Clamp-Hose
3:1	46-6560	1	Bushing	9	126-3949	1	Sender-Level, Fuel (W/Gasket)
4	116-2288	1	Fitting-Elbow, 90 DEG	9:1	126-3950	1	Gasket-Sender
5	126-1789	1	Cap-Fuel, Ratcheting	10	3253-17	5	Washer-Lock
6	1-603770	1	Valve-Fuel	11	3290-500	5	Screw-PPH

# Engine Assembly

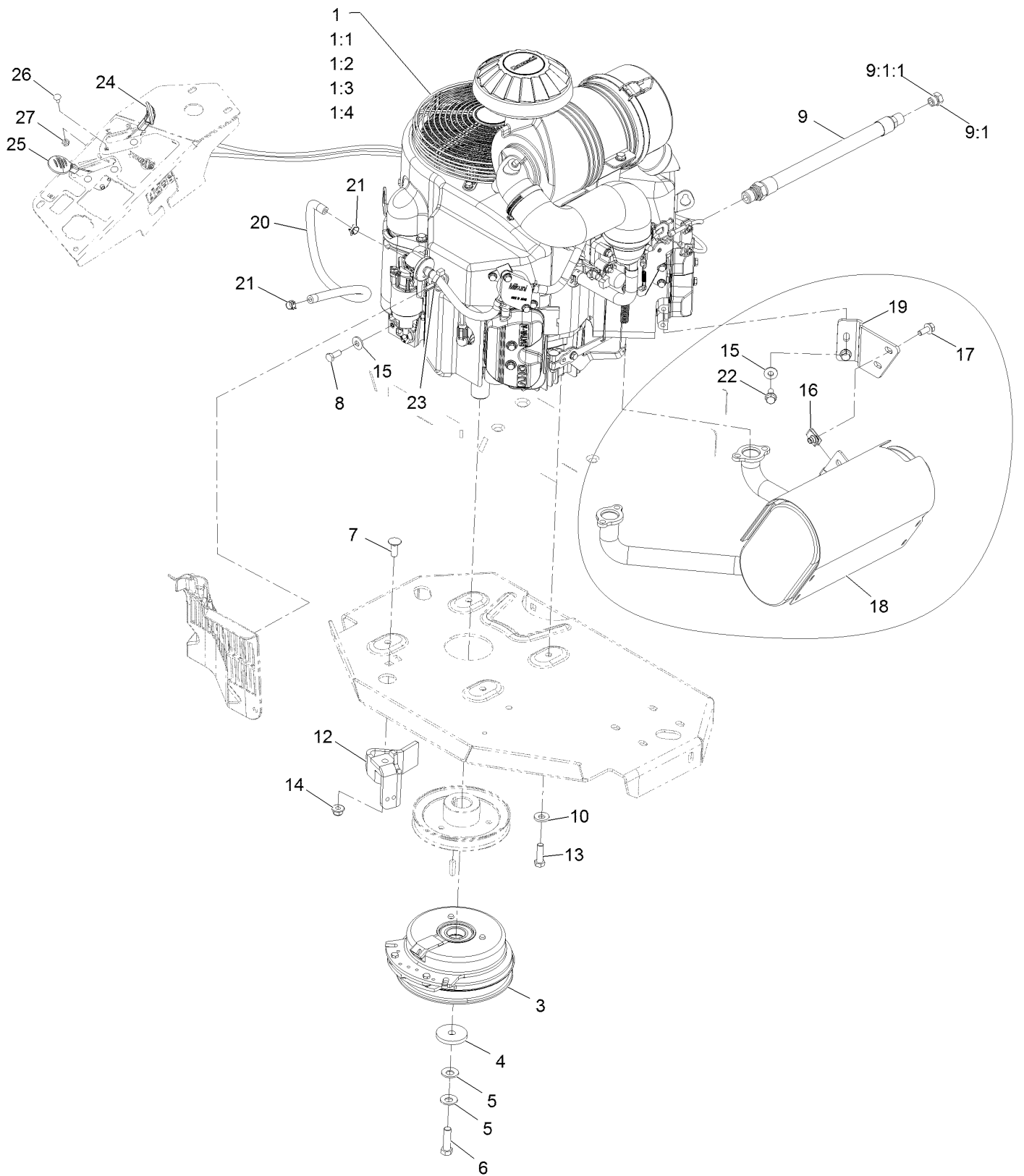

## Engine Assembly (continued)

<i>Ref.</i>	<i>Part Number</i>	<i>Qty.</i>	<i>Description</i>	<i>Ref.</i>	<i>Part Number</i>	<i>Qty.</i>	<i>Description</i>
1		1	Engine-Kawasaki, Fx751V-S07-R ▲◆	9:1:1	237-42	1	O-Ring
1:1		1	Kawasaki 49065-2078 Engine Oil Filter ▲◆	10	98-5975	4	Washer-Belleville
1:2		1	Kawasaki 49019-0031 Fuel Filter ▲◆	12	116-2612-01	1	Clutch-Anchor
1:3		1	Kawasaki 11013-7039 Safety Filter ▲◆	13	323-7	4	Screw-HH
1:4		1	Kawasaki 11013-7038 Air Filter ▲◆	14	104-8301	1	Nut-HF, NI
3	116-1620	1	Clutch Kit	15	1-303334	3	Washer-Spring
4	109-6919	1	Washer-Clutch	16	94-2413	2	Nut-U
5	1-603610	2	Washer-Spring	17	3234-5	2	Screw-HHF
6	109-9761	1	Screw-HH □	18	135-7562	1	Kit, Muffler
7	3231-22	1	Screw-CARR	19	116-0203	1	Bracket-Muffler
8	33114-020	1	Screw-HH	20	109-0298	1	Line-Fuel
9	116-4924	1	Engine Oil Drain Hose ASM ■	21	2412-98	2	Clamp-Hose
9:1	353-508	1	Plug-HH ●	22	95-4184	2	Screw-HHF
				23	105-1853	2	Clamp-Hose
				24	109-8167	1	ASM, Choke Cable
				25	116-1972	1	ASM,Throttle Cable
				26	1-807513	4	Bolt-CARR
				27	3296-2	4	Nut-Lock, NI

● Torque to 24-26 ft-lb

▲ Not serviced separately

□ Use Pro-Lock, Nut Type (P/N 1-840022, .5ml tube) on threads.

■ Torque to 23-29 ft-lb

◆ Obtain parts from [www.kawpower.com](http://www.kawpower.com)





## Hydraulic Assembly (continued)

<i>Ref.</i>	<i>Part Number</i>	<i>Qty.</i>	<i>Description</i>	<i>Ref.</i>	<i>Part Number</i>	<i>Qty.</i>	<i>Description</i>
1	116-1255	1	Pump Idler ASM	13	116-0171	1	RH Hydro Guard ASM
2	109-6658	1	Nut-Nyloc 3/8-16 Flg	13:2	116-8726	1	Decal-Oil, Hydro
3	135-7903	1	Hydro-LH	14	109-9057	1	Guard-Hydro, Rear (LH)
4	126-9835	1	Belt-V	15	109-9058	1	Guard-Hydro, Rear (RH)
5	116-6317	1	Spring-Extension	16	1-803035	2	Rivet 3/16 X 1/4
6	116-7558	1	Cradle-Hydro	17	116-2362	1	Deflector-Air Flow
7	116-1502	1	Bolt-Shoulder, Carriage	18	109-9905	1	Sheave
8	126-0095	6	Screw-CARR	19	1-807259	1	Key-Machine 1/4 X 1/4 X 1
9	99-5107	6	Nut-Lock	99	109-9828	1	Oil-HYD, (Quart) ●
10	325-8	4	Screw-HH	99	116-0164	1	Filter-Hydro ●
11	135-7904	1	Hydro-RH	99	116-1218	1	Oil-HYD, 1 Gallon ●
12	116-0170	1	LH Hydro Guard ASM	99	126-8103	1	Kit, Hydro Service ●
12:2	116-8726	1	Decal-Oil, Hydro				

● Not illustrated

# LH Hydro Assembly No. 135-7903

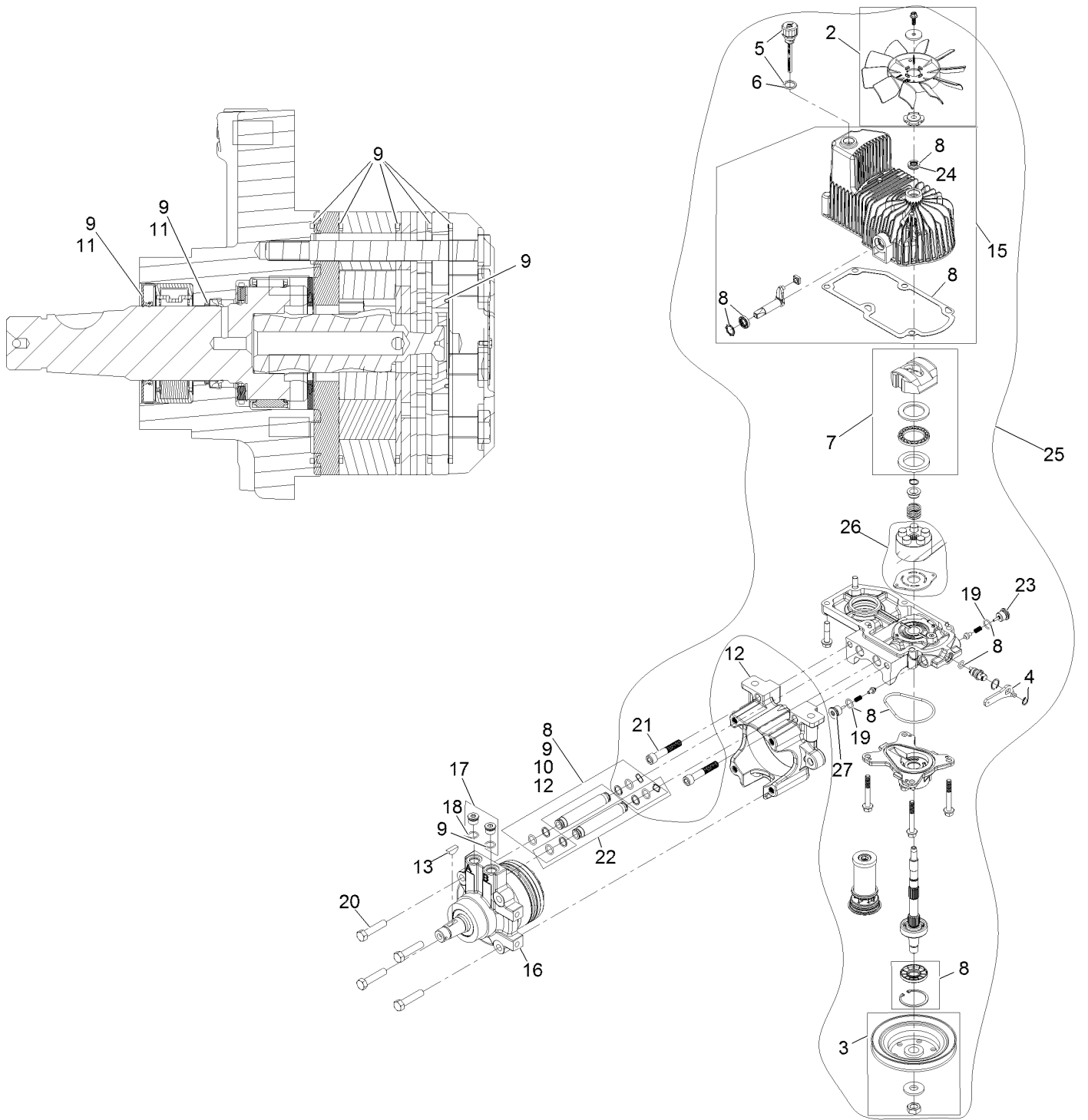

## LH Hydro Assembly No. 135-7903 (continued)

<i>Ref.</i>	<i>Part Number</i>	<i>Qty.</i>	<i>Description</i>	<i>Ref.</i>	<i>Part Number</i>	<i>Qty.</i>	<i>Description</i>
2	142-3603	1	Kit, 7.8 In Fan	17	116-7901	1	Magnetic Plugs Service Kit
3	116-0234	1	Pulley Kit	18	76-1900	2	O-Ring
4	116-0235	1	Handle	19	116-8662	2	O-Ring-Valve, Check
5	116-0236	1	Dipstick	20	116-8974	4	Screw-HH 1/2-20 X 2 1/4
6	116-0237	1	Gasket	21	116-8975	2	Screw-HSH 1/2-20 X 2 3/4
7	116-1367	1	Swash Block Kit	22	116-9922	2	Hydraulic Tube Kit
8	142-3604	1	Kit, Pump Seal	23	126-7466	1	Valve-Shock
9	116-1369	1	Motor Seal Kit	24	126-7711	1	Seal-Drive, Fan
10	116-1370	1	Tube Seal Kit	25	142-3609	1	Kit, Pump Section 12Cc LH
11	116-1371	1	Output Shaft Seal Kit	26	142-4500	1	Kit - 12Cc Port Plate, Rotate Grp
12	116-5469	1	Cup-Nose				
13	3257-42	1	Key-Woodruff 5/16 X 1	27	142-4459	1	Shock Valve Orificed 3800
15	142-4460	1	Kit, Housing-Hydro LH	99	116-1373	1	Flow Test Kit ●
16	116-8915	1	Motor-Hydraulic	99	116-4245	1	Puller-Pulley ●

● Not illustrated

# RH Hydro Assembly No. 135-7904

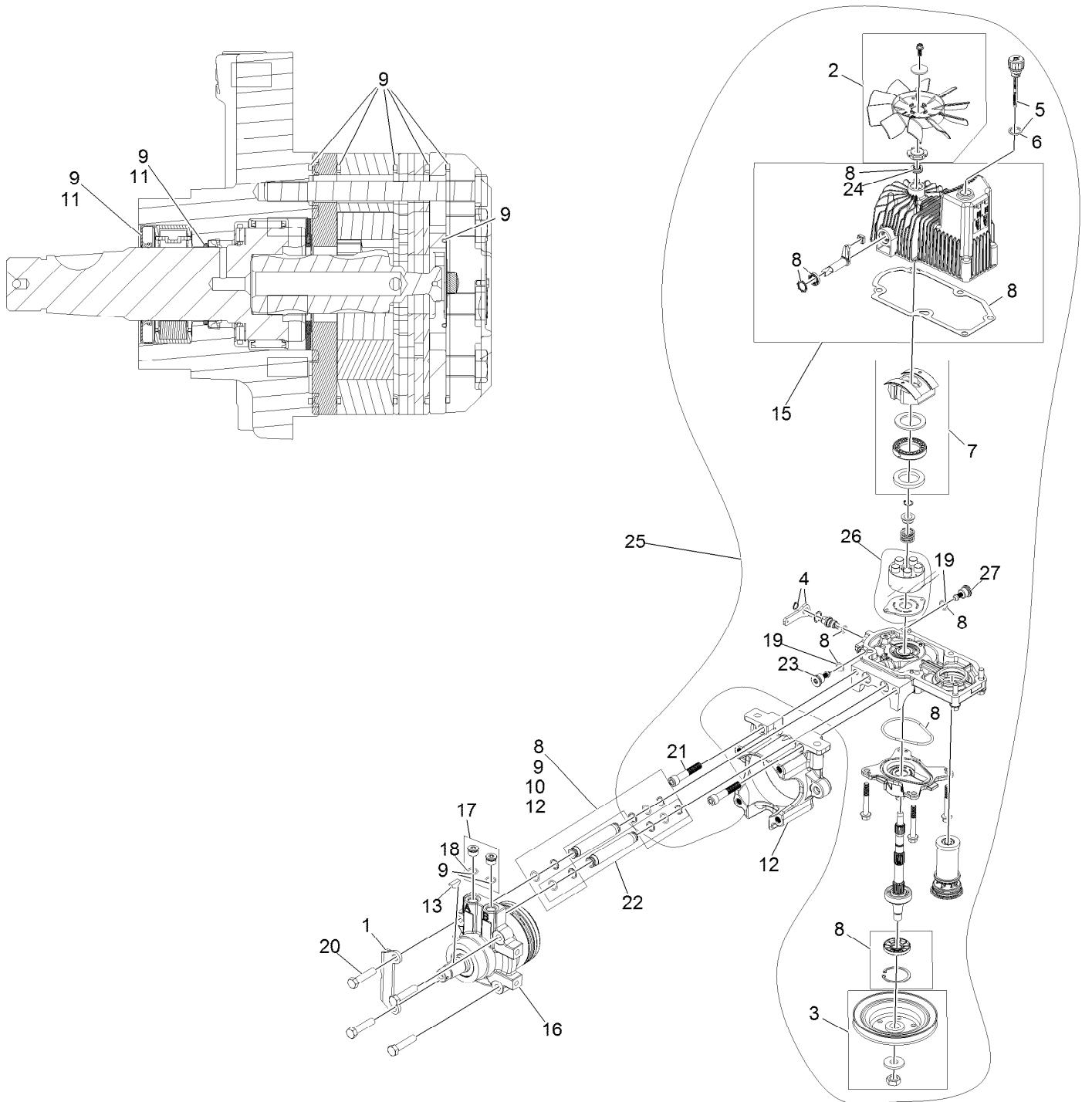

## RH Hydro Assembly No. 135-7904 (continued)

<i>Ref.</i>	<i>Part Number</i>	<i>Qty.</i>	<i>Description</i>	<i>Ref.</i>	<i>Part Number</i>	<i>Qty.</i>	<i>Description</i>
1	135-7827	1	Plate, Horse Shoe Mount	17	116-7901	1	Magnetic Plugs Service Kit
2	142-3603	1	Kit, 7.8 In Fan	18	76-1900	2	O-Ring
3	116-0234	1	Pulley Kit	19	116-8662	2	O-Ring-Valve, Check
4	116-0235	1	Handle	20	116-8974	4	Screw-HH 1/2-20 X 2 1/4
5	116-0236	1	Dipstick	21	116-8975	2	Screw-HSH 1/2-20 X 2 3/4
6	116-0237	1	Gasket	22	116-9922	2	Hydraulic Tube Kit
7	116-1367	1	Swash Block Kit	23	126-7466	1	Valve-Shock
8	142-3604	1	Kit, Pump Seal	24	126-7711	1	Seal-Drive, Fan
9	116-1369	1	Motor Seal Kit	25	142-3608	1	Kit, Pump Section 12Cc RH
10	116-1370	1	Tube Seal Kit	26	142-4500	1	Kit - 12Cc Port Plate, Rotate Grp
11	116-1371	1	Output Shaft Seal Kit				
12	116-5469	1	Cup-Nose	27	142-4459	1	Shock Valve Orificed 3800
13	3257-42	1	Key-Woodruff 5/16 X 1	99	116-1373	1	Flow Test Kit ●
15	142-4461	1	Kit, Housing-Hydro RH	99	116-4245	1	Puller-Pulley ●
16	116-8916	1	Motor-Hydraulic RH 240Cc				

● Not illustrated

# Pump Idler Assembly No. 116-1255



## Pump Idler Assembly No. 116-1255 (continued)

<i>Ref.</i>	<i>Part Number</i>	<i>Qty.</i>	<i>Description</i>	<i>Ref.</i>	<i>Part Number</i>	<i>Qty.</i>	<i>Description</i>
2	43-0940	1	Spacer	8	323-8	1	Screw-HH
3	103-3504	2	Bearing-Spherical	9	32120-10	2	Ring-Snap
4	103-3505	1	Seal-Lip, Double	10	302-19	1	Fitting-Grease
5	103-3506	1	Seal-Lip, Single	11	109-8076	1	Pulley-Idler
6	109-6658	1	Nut-Flange, NI	12	132-4724	1	Pin-Anchor, Spring
7	106-7159	2	O-Ring				

# Electrical Assembly

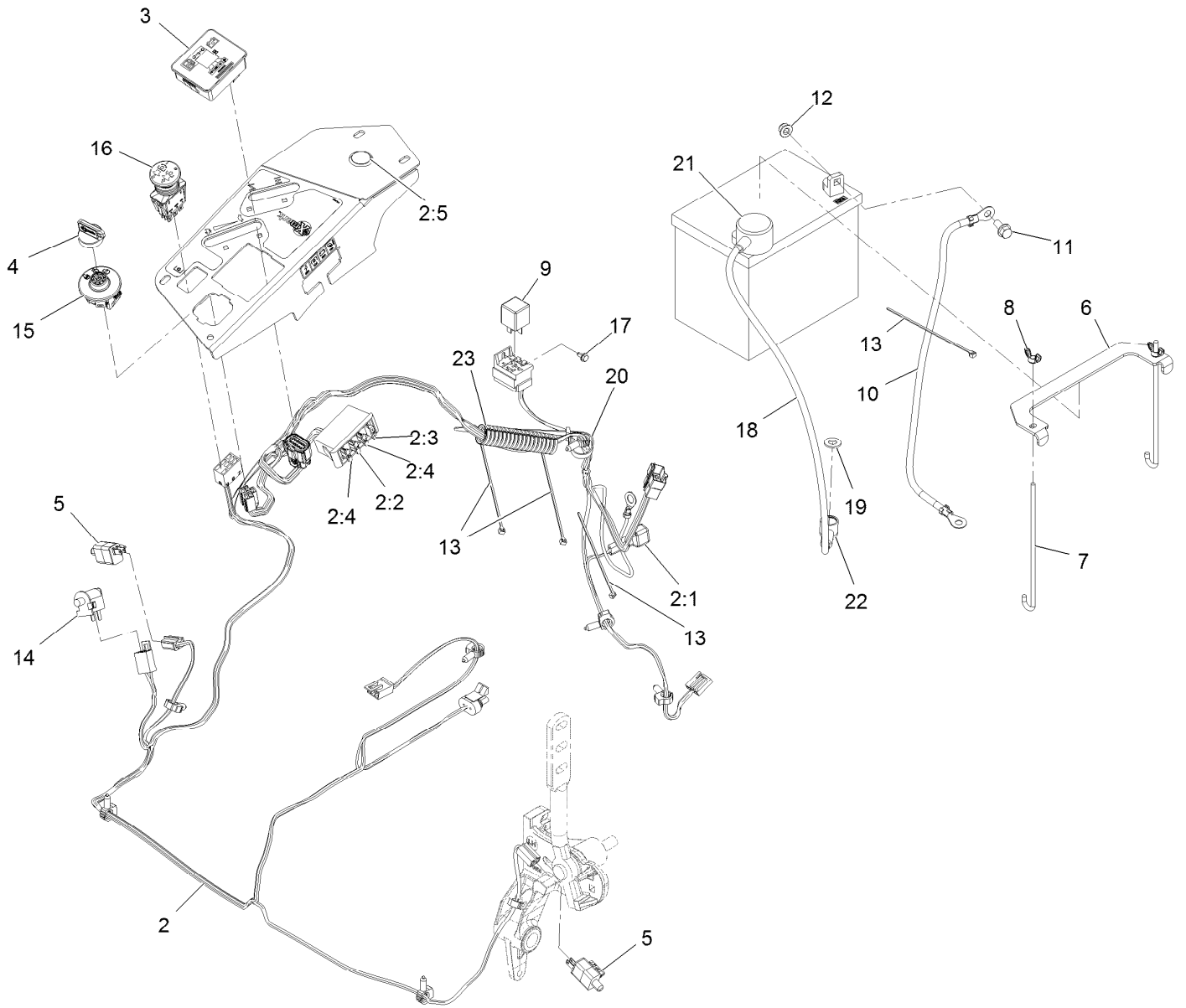



## Electrical Assembly (continued)

<i>Ref.</i>	<i>Part Number</i>	<i>Qty.</i>	<i>Description</i>	<i>Ref.</i>	<i>Part Number</i>	<i>Qty.</i>	<i>Description</i>
2	116-6009	1	Harness-Wire, Main ●	10	114-1218	1	Cable-Battery, Negative
2:1	103-3895	1	Diode	11	3234-5	2	Screw-HH Flg 5/16-18 X 3/4
2:2	218-578	1	Fuse-Blade, 10 Amp	12	104-8300	2	Nut-Nyloc 5/16-18 Flg
2:3	109355	1	Fuse-Blade, 15 Amp	13	1-303287	5	Tie-Cable 5 1/2 (Small)
2:4	109102	2	Fuse-Blade, 25 Amp	14	82-2190	1	Switch
2:5	116-0053	1	Cap-Plug	15	137-4100	1	Switch-Ignition
3	117-3882	1	Fuel/Hour Meter ASM	16	116-0124	1	Switch-PTO, 10 Amp
4	1-603511	1	Key-Ignition	17	104-2065	1	Screw-HWH #10-24 X 3/8
4	103-2106	1	Key-Exmark Logo	18	115-3864	1	Cable-Battery, Positive
5	110-6765	2	Switch	19	3256-24	1	Washer-3/8 SAE
6	116-0042-03	1	Strap-Tie Down, Battery	20	3290-378	1	Tie-Cable
7	1-633651	2	Bolt-Holddown	21	109-2407	1	Insulator-Battery
8	1-543792	2	Wingnut-Nyloc 1/4-20	22	1-543393	1	Insulator-Solenoid
9	1-643275	1	Relay-12Vdc 40 Amp	23	131-8846	1	Cover-Hose

● Use dielectric grease on all unsealed connectors and terminals only. Do not apply in sealed connectors.

**Notes:**



# MAXIMIZE THE PERFORMANCE OF YOUR EXMARK MACHINE.



## EXMARK® PREMIUM ENGINE OIL

Exmark now offers a family of engine oil viscosities to perform well in any environment. Each viscosity has the same synthetic formulation to give you what you need in punishing conditions. We designed each grade to the highest quality, making it ideal even for diesel applications. Coupled with Exmark Premium Fuel Treatment, we have the performance products to make your machine hum.

### EXMARK PREMIUM ENGINE OIL SAE 30/10W-30

- Meets zero shear requirements of a straight grade SAE 30 as well as the cold temp properties of a 10W-30.
- Most versatile oil in the industry.
- Superior corrosion protection over conventional oil - even in corrosive, humid environments.

### EXMARK PREMIUM ENGINE OIL SAE 20W-50

- Perfect for your big block engine, or any application in severe service.
- Same full synthetic formulation as all other Exmark Premium viscosities.
- Also effective for use in severe service small block engines.

### EXMARK PREMIUM ENGINE OIL SAE 10W-50

- Full synthetic formulation gives you peak performance. Don't settle for less.
- Wide span multi-grade combines easy starting in cold weather with maximum protection in high temperature operation.
- Reduce friction & wear over standard mineral formulations.

### EXMARK PREMIUM ENGINE OIL SAE 0W-40

- The perfect choice for when the weather turns cold or unpredictable, and your Exmark UTV has to perform.
- Commercial quality for severe service.
- Advanced additive package helps prevent corrosion from long-term storage.

### EXMARK PREMIUM ENGINE OIL UTV FORMULATION

- 4-cycle high-temp formulation.
- Heavier viscosity, full synthetic, perfect for your UTV.

### EXMARK PREMIUM UTV EXTREME CONDITIONS GEAR OIL

- SAE 80W-90, designed to keep your UTV performing at its peak.
- Shear stable, hypoid gear lube.
- Includes a premium additive system to combat wear, oxidation, rust & corrosion.

*Available from your local Exmark dealer. Find your closest dealer at [exmark.com](http://exmark.com)*

## EXMARK ACCESSORIES AND OPTIONS\*

### MID-MOUNT RIDING ACCESSORIES AND OPTIONS

CUSTOM RIDE SEAT SUSPENSION SYSTEM	OPERATOR CONTROLLED DISCHARGE
FULL SUSPENSION SEAT	SUN SHADE
DECK LIFT ASSIST KIT	TRASH CONTAINER
HITCH KIT	TURF STRIPER
LIGHT KIT	ULTRA VAC COLLECTION SYSTEM
12V POWER PORT	ULTRA VAC QUICK DISPOSAL SYSTEM
MICRO-MULCH SYSTEM	

### OUT-FRONT RIDING ACCESSORIES AND OPTIONS

CUSTOM RIDE SEAT SUSPENSION SYSTEM	SNOW BLADE
DUAL-TAIL WHEEL	SNOWBLOWER
FLOOR PAN EXTENDER	SUN SHADE
HITCH KIT	TRASH CONTAINER
LIGHT KIT	ULTRA VAC COLLECTION SYSTEM
MICRO-MULCH SYSTEM	ULTRA VAC QUICK DISPOSAL SYSTEM
ROLL OVER PROTECTION SYSTEM (ROPS)	WEATHER CAB

### WALK-BEHIND ACCESSORIES AND OPTIONS

GRASS CATCHER	TURF STRIPER
MICRO-MULCH SYSTEM	STANDON

\*Some accessories and options not available for some models.

Place Model No. and Serial No.  
Label Here (Included in the Literature  
Pack) or Fill in Below

Model No. \_\_\_\_\_

Serial No. \_\_\_\_\_

Date Purchased \_\_\_\_\_

Engine Model No. and Spec. No. \_\_\_\_\_

Engine Serial No. (E/No) \_\_\_\_\_

© 2020 Exmark Mfg. Co., Inc.  
415 Industrial Row  
Beatrice, NE 68310  
All Rights Reserved

Part No. 4504-625 Rev. B  
(402) 223-6375  
Fax (402) 223-5489  
Printed in the USA.

