

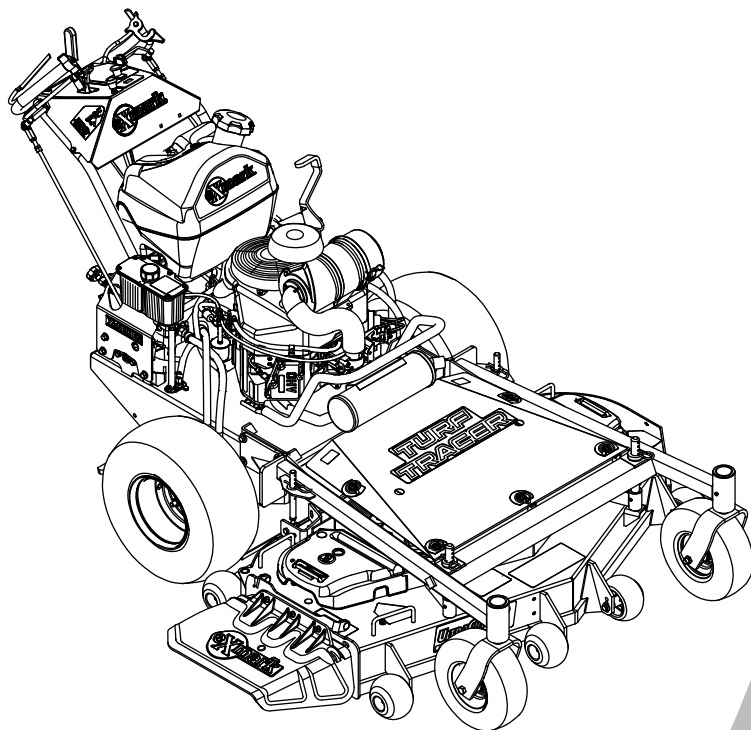

# **TURF TRACER® X-SERIES**

**Model No. TTX650EKC60400—Serial No. 406294345 and Up**

Picture below may not reflect actual product.



# **Parts Manual**

Part No. 4504-590 Rev. B

# Ordering Replacement Parts

To order replacement parts, please supply the part number, the quantity, and the description of each part desired.

## Understanding Reference Numbers

Each identified part in an illustration has a reference number. The reference number for a part also appears in the parts list, along with other information about the part.

This catalog uses two special reference number formats, one to indicate parts in a service assembly and another to indicate the quantity of a given part in an illustration.

## Service Assembly Reference Numbers

Parts in service assemblies have reference numbers in the form a:b. The a represents the reference number of the entire service assembly and the b represents a sequential number unique to each part within the service assembly.

For example, a wheel assembly might be identified by reference number 6, the tire by 6:1, the valve by 6:2, and the wheel by 6:3. When you order the assembly identified by reference number 6, you receive all parts identified by reference numbers 6:1, 6:2, and 6:3. However, you may also order any part individually. Reference numbers of this type appear in illustration and in parts lists.

## Reference Numbers Indicating Quantity

In an illustration, if a reference number indicates more than one part, the reference number has the form nX y. The n represents the quantity of the part, the X is the multiplication symbol, and the y represents the reference number.

For example, in an illustration, the reference number 2X 37 means that two of the parts identified by reference number 37 are indicated.

# Touch Up Paint

Exmark black touch up spray paint – gloss black.

Exmark red touch up paint (spray paint – P/N 1-850337 - .6 oz liquid bottle – P/N 103-9140).



If your Exmark dealer does not have the Exmark part in stock, Exmark will get the parts to the dealer the next business day or the part will be FREE Guaranteed!! (Some restrictions apply. See your participating Exmark Dealer for details.)

## Contents

Complete Deck Assembly.....	4
Deck Assembly.....	6
Deck W/Decals Assembly.....	8
Deck Idler Assembly No. 126-2314.....	10
Main Frame Assembly.....	12
Front Frame Assembly.....	14
Engine Deck Assembly.....	16
Handle Assembly.....	18
Controls Assembly.....	20
Fuel Assembly.....	22
Engine Assembly.....	24
Hydro Assembly.....	26
Electrical Assembly.....	28

# Complete Deck Assembly

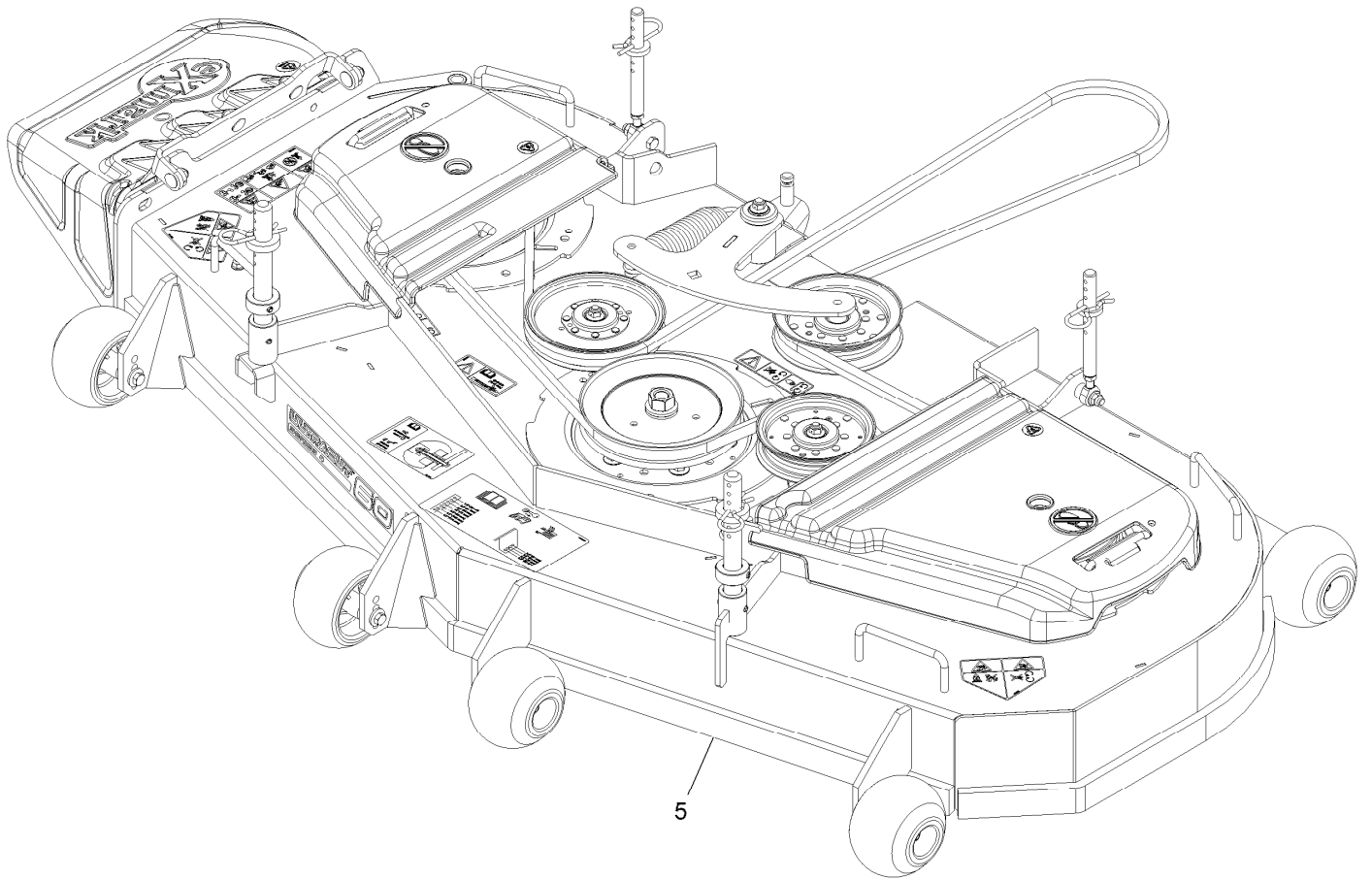

# Complete Deck Assembly (continued)

<i>Ref.</i>	<i>Part Number</i>	<i>Qty.</i>	<i>Description</i>
5	126-2537	1	ASM, Complete Deck, 60

# Deck Assembly

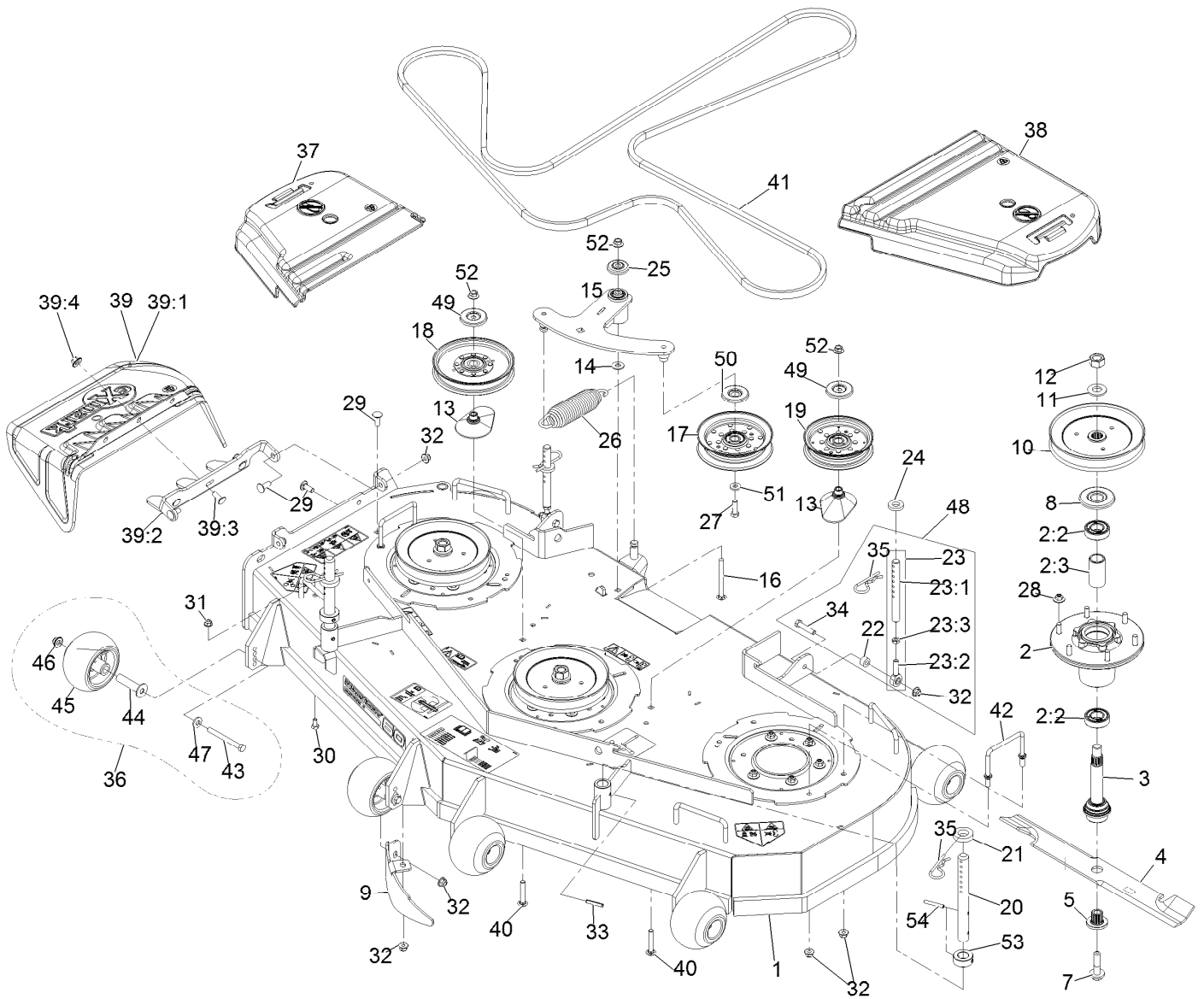

## Deck Assembly (continued)

Ref.	Part Number	Qty.	Description	Ref.	Part Number	Qty.	Description
1	126-2570	1	ASM, Deck W/ Decals, 60"	26	116-6317	1	Spring-Extension
2	116-3344	3	ASM-Cutter Hsg With Bearings	27	323-7	1	Screw-HH
2:2	116-0720	2	Bearing-Ball	28	109-6658	18	Nut-Flange, NI
2:3	116-3312	1	Spacer-Bearing	29	3231-22	4	Screw-CARR
3	116-3341	3	ASM-Spindle And Seal □	30	322-2	1	Screw-HH
4	116-5174	3	Blade-Extreme 2, 20.50" ●	31	104-8300	1	Nut-HF, NI
4	103-6403	3	Blade, Notched	32	104-8301	10	Nut-HF, NI
4	103-6393	3	Blade, Mulching ◆	33	1-806332	2	Roll Pin, 1/4 X 1-1/2
4	103-6388	3	Blade, Low Lift ●	34	323-9	2	Screw-HH
4	103-6383	3	Blade, Solid ●	35	1-806009	4	Hairpin, .177
5	103-3037	3	Bushing, Splined	36	116-9981	6	Kit, Anti-Scalp Roller
7	109-9220	3	Screw-Sems ■ ○	37	116-0094	1	Cover-Belt, RH
8	116-1286	3	Guard,Bearing Top .989	38	109-6938	1	Cover-Belt, LH
9	116-5614-01	1	Dogleg - Lz60	39	109-7188	1	ASM,Discharge Chute
10	116-0676	3	Sheave,Blade Drive 7.25	39:1	109-2738	1	Chute, Discharge
11	103-2802	3	Washer	39:2	109-8675-01	1	Bracket,Discharge Chute
12	116-7306	3	Nut-Hex ▲	39:3	3231-22	3	Screw-CARR
13	109-2872	2	Spacer-Pulley	39:4	109-6658	3	Nut-Flange, NI
14	3256-4	1	Washer-Flat	40	3231-40	2	Bolt-CARR
15	126-2314	1	ASM, Deck Idler	41	126-2539	1	Belt, Deck Drive
16	3231-24	1	Screw-CARR	42	109-6982	2	Wireform-Cover
17	126-9196	1	Idler-Pulley, Flat	43	116-9362	6	Screw-HH
18	126-7685	1	Idler-Pulley	44	116-8131	6	Axle, Roller
19	126-9187	1	Pulley-Idler, Flat	45	103-8415	6	Roller-Anti-Scalp
20	135-4829	2	Rod, Deck Support	46	109-6658	6	Nut-Flange, NI
21	1-413425	2	Spacer-Deck Support	47	98-5975	6	Washer-Belleville
22	1-603050	2	Spacer	48	1-411532	2	Kit, Support Link W/Pin
23	1-414521	2	Link Assy	49	126-8043	2	Shield-Dust
23:1	1-413525	1	Link, Rear Deck Support	50	126-9195	1	Shield-Guard, Dust
23:2	1-613204	1	Balljoint	51	43-0940	1	Spacer
23:3	3220-3	1	Nut-HJ	52	32128-19	3	Nut-HF
24	1-323539	2	Spacer	53	135-4828	2	Collar, Deck Height Pin
25	103-2916	1	Guard-Top	54	32121-32	2	Pin-Roll

● Optional Equipment

▲ Torque to 130-160 ft-lb

◆ Requires installation of mulch kit for proper mulching. See your Exmark dealer for details.

□ Apply Mobil HTS grease (P/N 103-5217 1.5 oz packet) (or a food-grade anti-seize). See operator s manual for locations.

○ Apply lubricant to threads as needed to prevent seizing. Copper based anti-seize preferable. Grease is an acceptable substitute.

■ Torque to 50-60 ft-lb

# Deck W/Decals Assembly

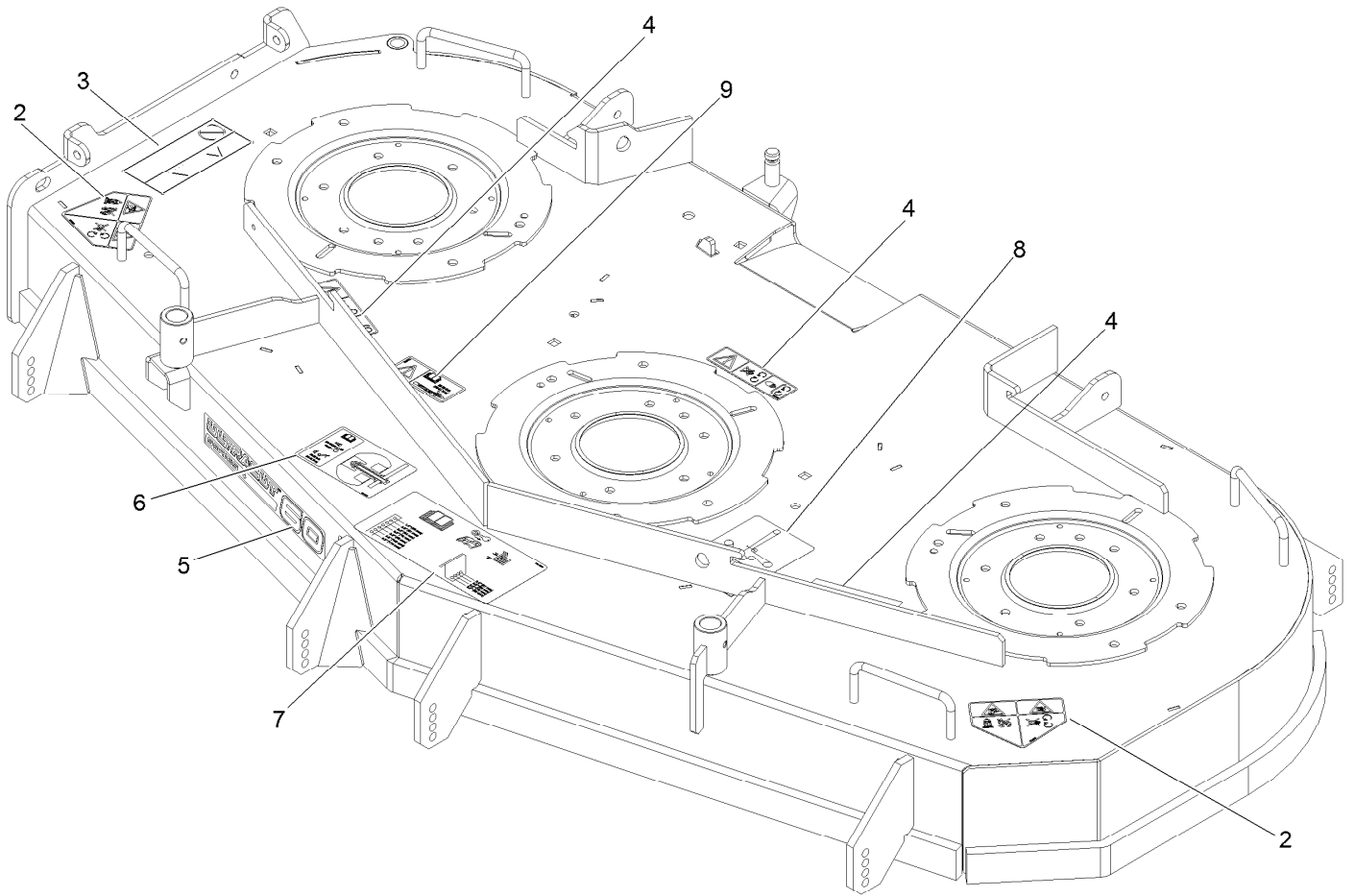



## Deck W/Decals Assembly (continued)

<i>Ref.</i>	<i>Part Number</i>	<i>Qty.</i>	<i>Description</i>	<i>Ref.</i>	<i>Part Number</i>	<i>Qty.</i>	<i>Description</i>
2	112-8760	2	Decal-Danger	6	126-0898	1	Decal-Roller Mounting
3	135-5210	1	Decal-Warning Thrown Obj	7	116-8278	1	Decal-Anti-Scalp
4	112-9028	3	Decal-Cover, Missing	8	116-8727	1	Decal-Belt Routing
5	126-6589	1	Decal, 604	9	116-8283	1	Decal-Torque, Bolt

# Deck Idler Assembly No. 126-2314

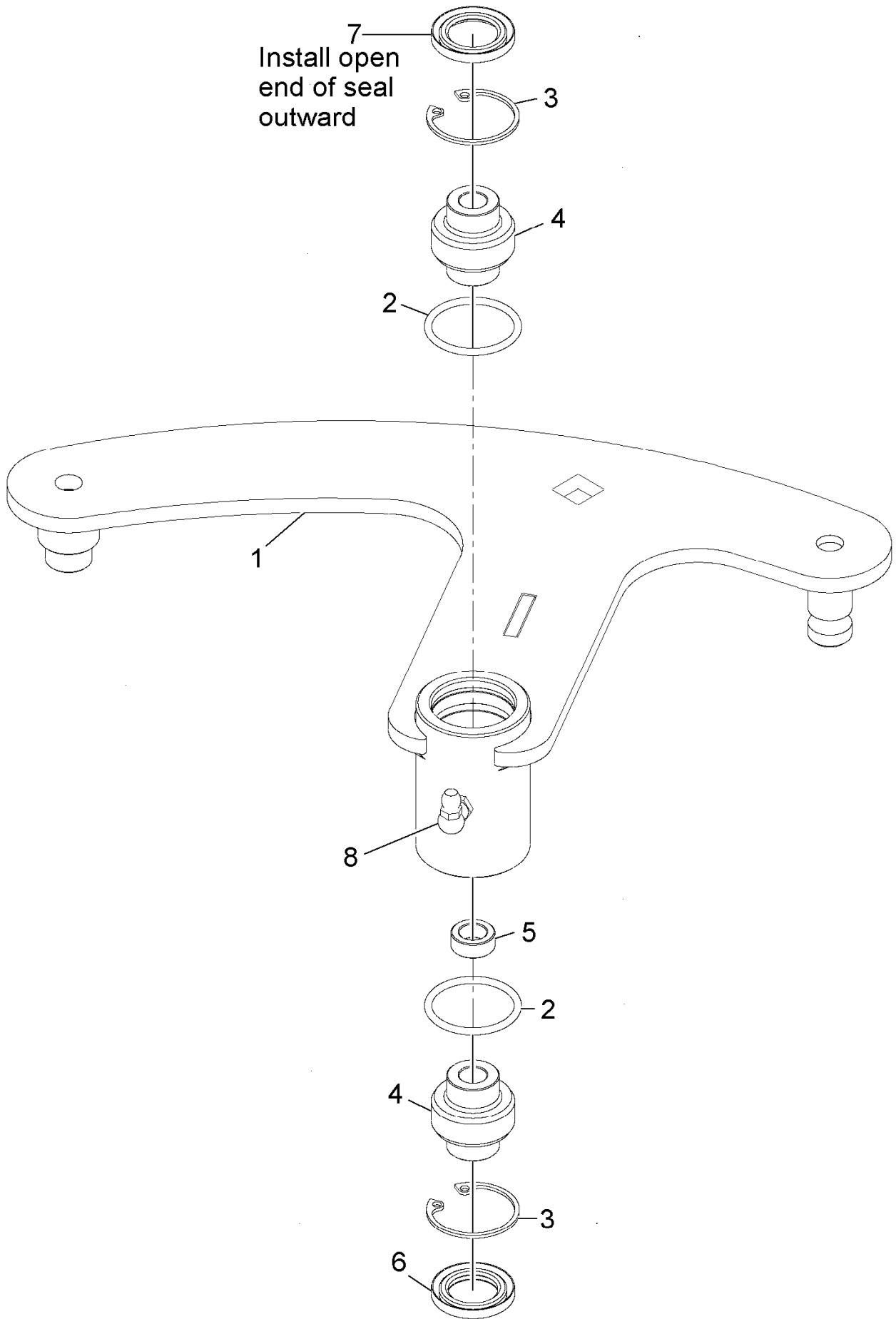

## Deck Idler Assembly No. 126-2314 (continued)

<i>Ref.</i>	<i>Part Number</i>	<i>Qty.</i>	<i>Description</i>	<i>Ref.</i>	<i>Part Number</i>	<i>Qty.</i>	<i>Description</i>
1		1	Weld, Idler Arm ●	5	103-5677	1	Spacer
2	106-7159	2	O-Ring	6	103-3505	1	Seal-Lip, Double
3	32120-10	2	Ring-Snap	7	103-3506	1	Seal-Lip, Single
4	103-3504	2	Bearing-Spherical	8	302-40	1	Fitting-Grease, 90 DEG

● Not serviced separately

# Main Frame Assembly

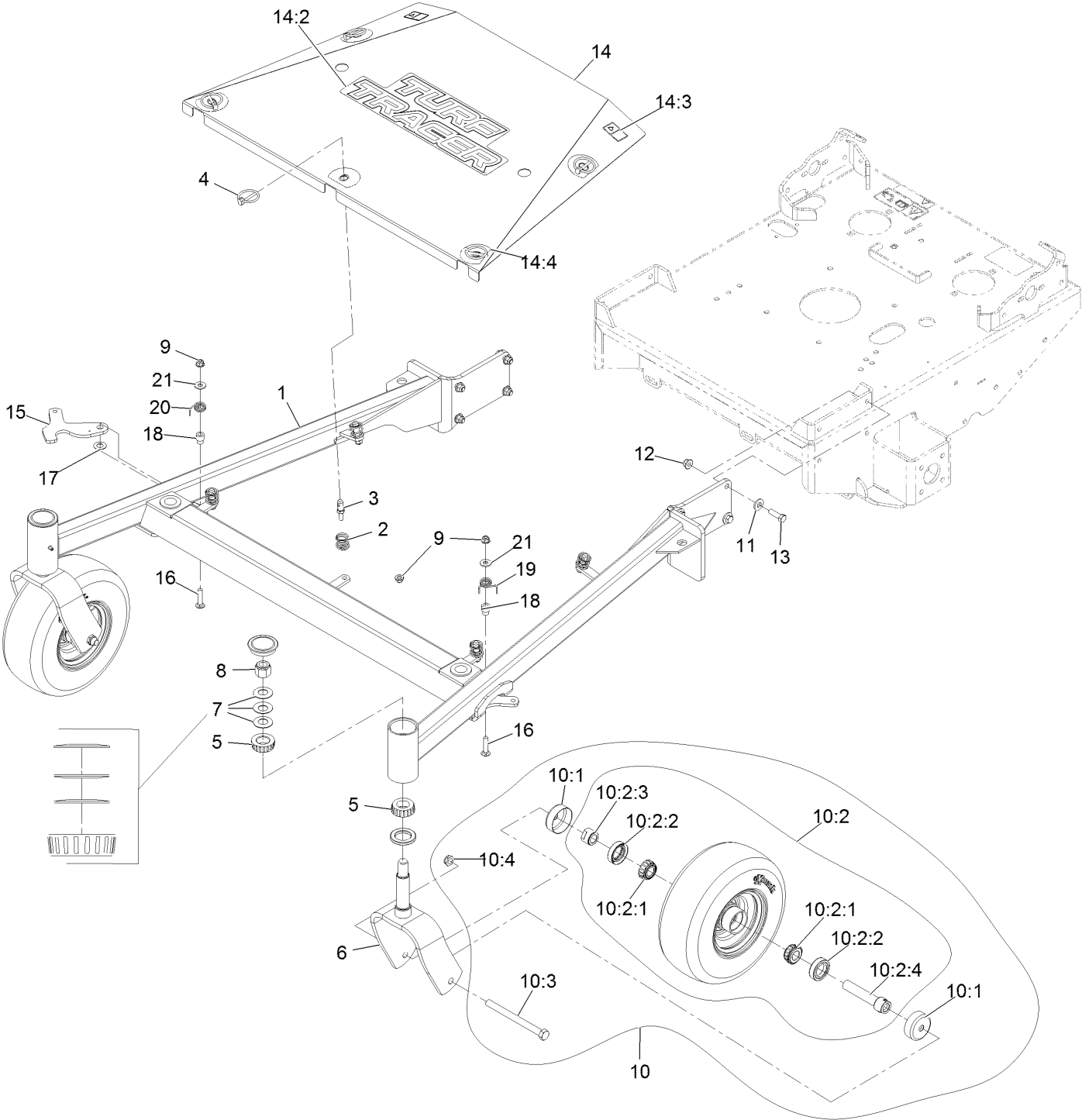

## Main Frame Assembly (continued)

<i>Ref.</i>	<i>Part Number</i>	<i>Qty.</i>	<i>Description</i>	<i>Ref.</i>	<i>Part Number</i>	<i>Qty.</i>	<i>Description</i>
1	126-2541	1	ASM, Front Frame W/ Bearings, 60	10:3	325-20	1	Screw-HH 1/2-13 X 6
2	126-1503	5	Spring	10:4	3296-45	1	Nut-Nyloc 1/2-13 Thin
3	135-7455	5	Pin, Spring	11	98-5975	8	Washer-Spring Disc 3/8
4	92-1298	5	Pin-Lynch	12	104-8301	8	Nut-Nyloc 3/8-16 Flg
5	1-543509	4	Cone-Bearing Tapered Roller	13	323-7	8	Screw-HH 3/8-16 X 1 1/4
6	103-1891-01	2	Wld, Caster Fork	14	126-2545	1	ASM, Center Shield W/ Decals, 60
7	1-633508	6	Washer-Spring Disc	14:2	126-6892	1	Decal-Turf Tracer
8	3296-51	2	Nut-Nyloc 3/4-10	14:3	106-5517	2	Decal-Warning
9	104-8300	7	Nut-Nyloc 5/16-18 Flg	14:4	126-1692	5	Decal-Scratch Cover
10	109-3524	2	Asm, Wheel And Bearings	15	135-4827-01	2	Latch, Deck Height
10:1	103-2768	2	Guard-Seal	16	3230-4	2	Bolt-Carriage 5/16-18 X 1 1/2
10:2		1	Wheel And Bearing ASM ●	17	110-4068	2	Washer-Plastic
10:2:1	1-633585	2	Bearing-Cone Tapered Roller	18	108-9087	2	Collar-Basket
10:2:2	103-0063	2	Seal-Double Lip	19	75-3960	1	Spring-Torsion, LH (Yellow)
10:2:3	103-3051	1	Spacer-Nut	20	75-3970	1	Spring-Torsion, RH
10:2:4	126-5359	1	Caster Axle ASM	21	3256-3	2	Washer-5/16 Std

● Not serviced separately

# Front Frame Assembly

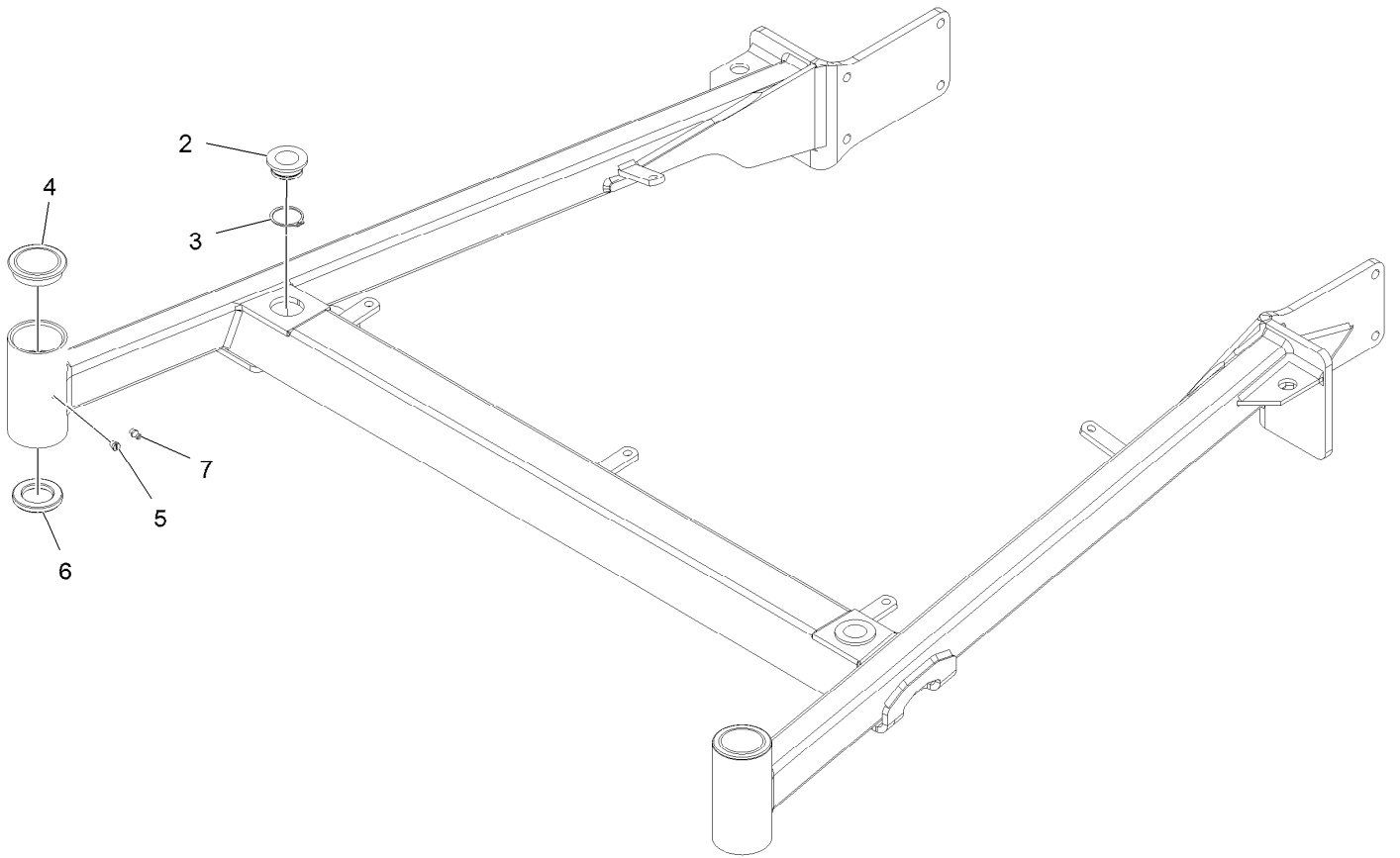

## Front Frame Assembly (continued)

<i>Ref.</i>	<i>Part Number</i>	<i>Qty.</i>	<i>Description</i>	<i>Ref.</i>	<i>Part Number</i>	<i>Qty.</i>	<i>Description</i>
2	1-513336	2	Bushing-Deck	5	1-811010	2	Plug
3	32120-33	2	Ring-Retaining	6	1-543511	2	Seal-Grease
4	103-4882	2	Cap-Grease	7	302-19	1	Zerk-1/4-28 Str

# Engine Deck Assembly

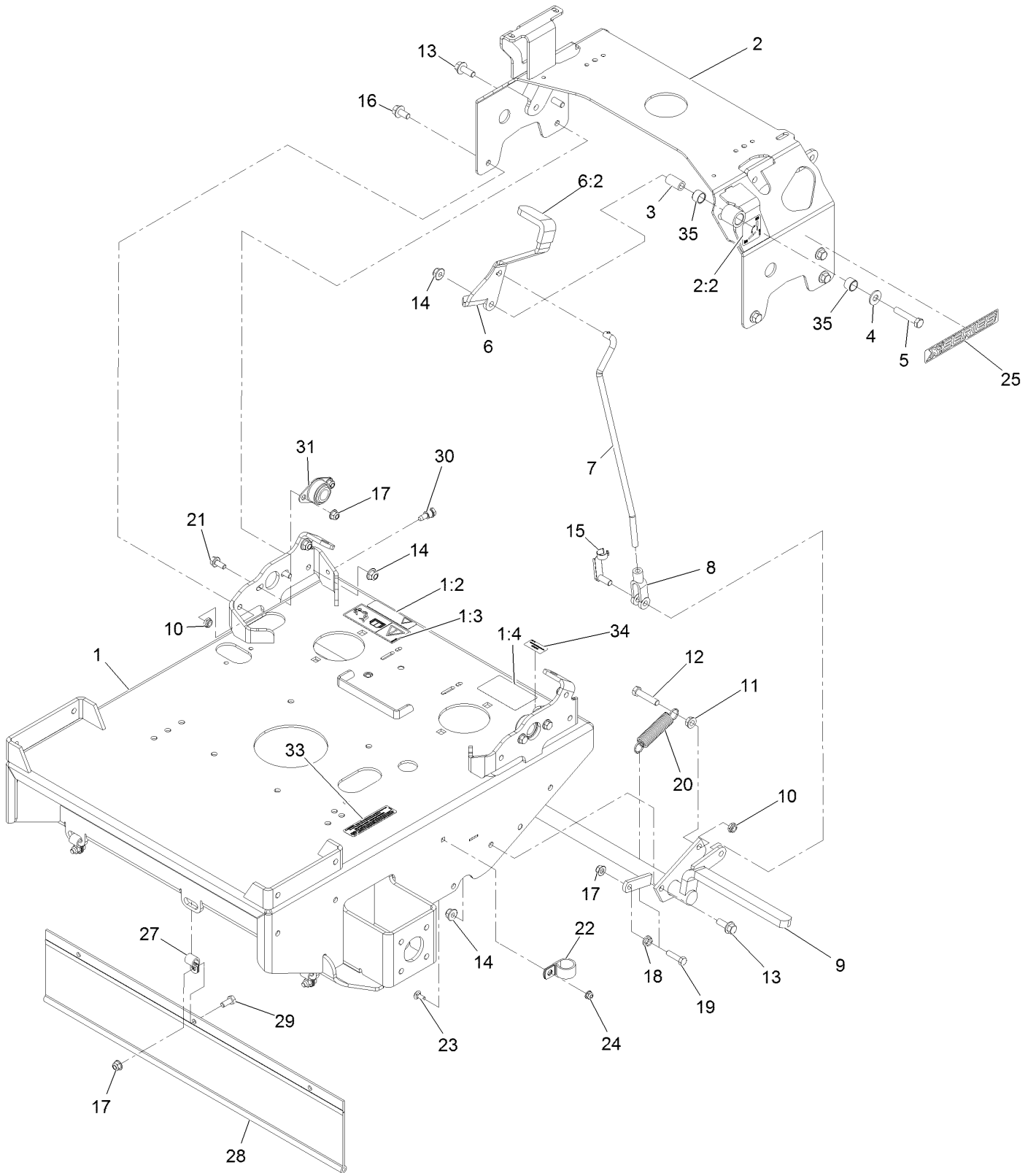



## Engine Deck Assembly (continued)

<i>Ref.</i>	<i>Part Number</i>	<i>Qty.</i>	<i>Description</i>	<i>Ref.</i>	<i>Part Number</i>	<i>Qty.</i>	<i>Description</i>
1	126-2521	1	ASM, Engine Deck W/ Decals	15	103-2399	1	Pin-Clevis Spring 3/8
1:2	98-1977	1	Decal-Warning	16	3234-12	2	Screw-HH Flg 3/8-16 X 3/4
1:3	126-1400	1	Decal-Warning, Sulky	17	104-8300	8	Nut-Nyloc 5/16-18 Flg
1:4	116-8253	1	Decal-Drive Release	18	32128-20	1	Nut-Whizlock 5/16-18
2	126-2181	1	ASM, Tank Support W/ Decal	19	322-6	1	Screw-HH 5/16-18 X 1 1/4
2:2	116-5988	1	Decal-Park Brake, CE	20	1-323161	1	Spring
3	1-413344	1	Bushing-Pivot	21	3234-47	4	Screw-HH Flg 5/16-18 X 3/4
4	3256-4	1	Washer-3/8 Std	22	1-643312	1	Clip-Loom
5	323-10	1	Screw-HH 3/8-16 X 2	23	3229-11	1	Bolt-Carriage 1/4-20 X 5/8
6	126-2180	1	ASM, Brake Lever W/ Grip	24	104-7201	1	Nut-Nyloc 1/4-20 Flg
6:2	1-303020	1	Grip-Lever	25	126-6573	2	Decal-X-Series
7	116-9960	1	Linkage-Brake	27	1-413510	3	Clip-Loom
8	1-633131	1	Yoke-Linkage, Brake	28	103-2224	1	Shield, Drag
9	116-9159	1	Wld,Brake Ttx	29	322-3	3	Screw-HH 5/16-18 X 3/4
10	3296-59	3	Nut-Nyloc 3/8-16 Thin	30	115-1958	1	Bolt-Shoulder
11	3290-357	1	Nut-Whizlock 3/8-16	31	1-633102	2	Bearing-Flanged
12	323-9	1	Screw-HH 3/8-16 X 1 3/4	33	133-8062	1	Decal-Arrestor, Spark
13	3234-42	7	Screw HHF 3/8-16 X 1	34	126-4345	1	Decal-Patent
14	104-8301	8	Nut-Nyloc 3/8-16 Flg	35	1-413347	2	Sleeve-Bushing

# Handle Assembly

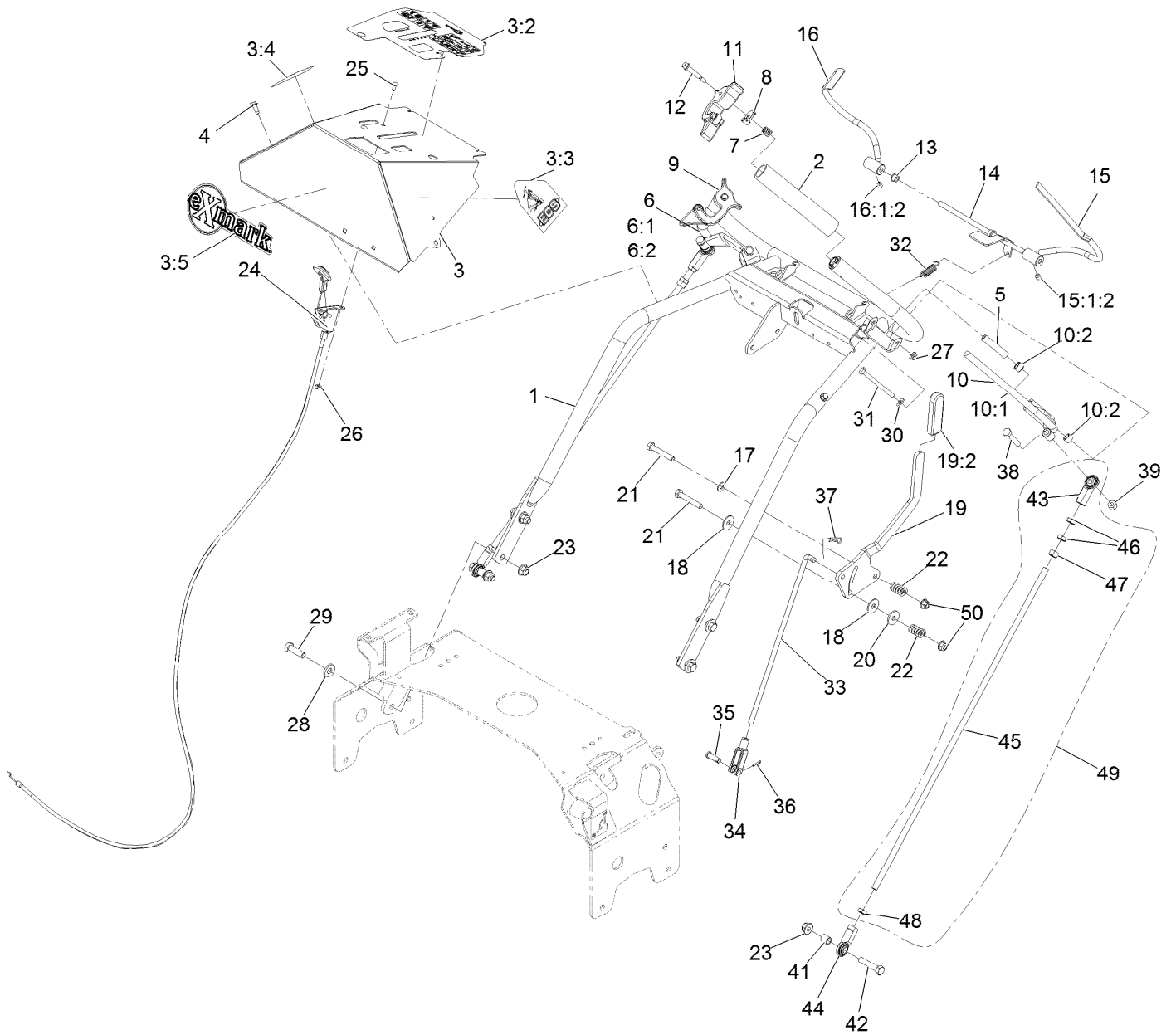

## Handle Assembly (continued)

<i>Ref.</i>	<i>Part Number</i>	<i>Qty.</i>	<i>Description</i>	<i>Ref.</i>	<i>Part Number</i>	<i>Qty.</i>	<i>Description</i>
1	126-2642-03	1	Weld, Handle	20	1-603716	1	Washer-Friction Disc
2	103-0815	2	Grip-Bar, Handle	21	322-11	2	Screw-HH 5/16-18 X 2 1/4
3	126-2820	1	ASM, Console W/ Decals	22	1-323245	2	Spring-Compression
3:2	135-2862	1	Decal-Console	23	104-8301	6	Nut-Nyloc 3/8-16 Flg
3:3	103-2242	1	Decal, Ecs Instruction LH	24	109-3958	1	Control-Throttle
3:4	103-2243	1	Decal, Ecs Instruction RH	25	1-807513	2	Bolt-Carriage #10-24 X 1/2
3:5	126-6877	1	Decal, Exmark Logo	26	3296-2	2	Nut-Nyloc #10-24
4	32144-10	2	Screw-HWH 1/4-20 X .62	27	104-7201	2	Nut-Nyloc 1/4-20 Flg
5	103-0027	2	Bushing-Lever, Drive	28	98-5975	4	Washer-Spring Disc 3/8
6	103-2513	1	Asm, Drive Lever RH	29	323-7	4	Screw-HH 3/8-16 X 1 1/4
6:1	116-4082	1	Wld,RH Drive Lever	30	3256-22	2	Washer-1/4 SAE
6:2	126-9366	2	Bushing, Sleeve	31	321-14	2	Screw-HH 1/4-20 X 2 3/4
7	1-633349	2	Spring-Compression	32	1-303363	1	Spring-Extension
8	126-2921	2	Latch, Ecs	33	1-413225	1	Rod, Speed Control
9	103-1371	1	Thumb Latch Asm RH	34	1-303105	1	Yoke-Adjustable
10	103-2514	1	Asm, Drive Lever LH	35	1-808280	1	Pin-Clevis 5/16 X 1 49/64
10:1	116-4081	1	Wld,LH Drive Lever	36	3272-5	1	Pin-Cotter 3/32 X 1/2
10:2	126-9366	2	Bushing, Sleeve	37	1-806003	1	Hairpin-Cotter
11	103-1372	1	Thumb Latch Asm LH	38	322-9	2	Screw-HH 5/16-18 X 1 3/4
12	126-2931	2	Screw-Shoulder	39	3296-29	2	Nut-Nyloc 5/16-18
13	1-303365	2	Bushing-Nylon	41	103-1166	2	Spacer-Tube, Pump Link
14	103-0769-03	1	Rod Weldment, OPC	42	323-9	2	Screw-HH 3/8-16 X 1 3/4
15	116-4079	1	Wld,LH OPC Lever ■	43	103-2463	4	Balljoint
15:1:2	1-803322	1	Setscrew-5/16-24 X 5/16 ●	44	103-1167	2	Joint-Ball End
16	116-4080	1	Wld,RH OPC Lever ■	45	103-1148	2	Rod,Drive Lever
16:1:2	1-803322	1	Setscrew-5/16-24 X 5/16 ●	46	3220-3	4	Nut-Jam 3/8-24
17	3256-23	1	Washer-5/16 SAE	47	3219-3	2	Nut-Hex 3/8-24
18	1-323244	2	Washer-Friction	48	3220-16	2	Nut-Jam 3/8-24 LH
19	126-0148	1	Lever, Shift W/Grip	49	116-3414	2	Drive Link ASM
19:2	103-5994	1	Grip-Handle, Steering	50	104-8300	2	Nut-Nyloc 5/16-18 Flg

● Use Pro-Lock, Nut Type (P/N 1-840022, .5ml tube) on threads.

■ Use Pro-Lock retaining type, Part no. 1-840023 (.5cc tube) on inside of bore of OPC hub.

# Controls Assembly

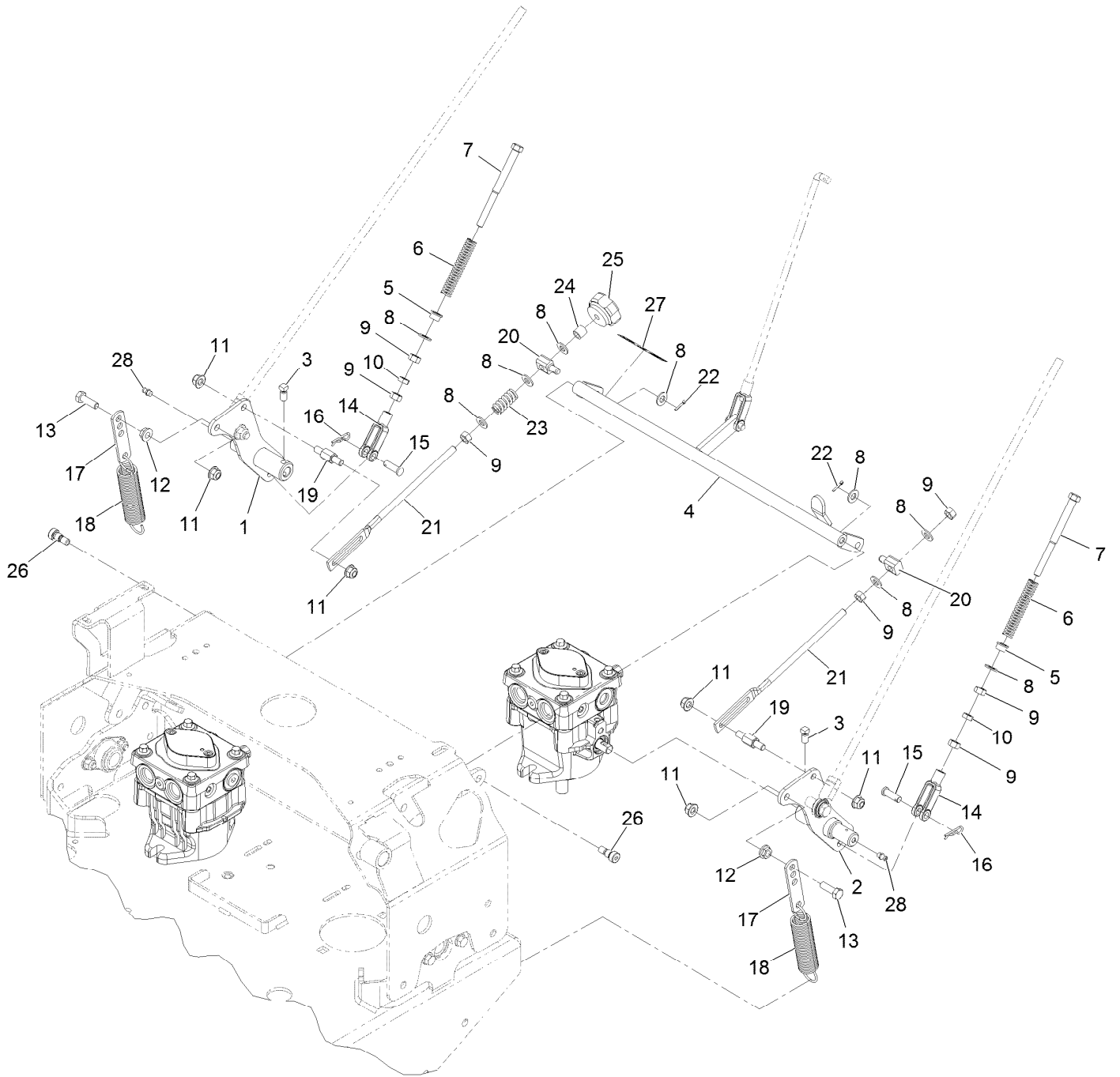

## Controls Assembly (continued)

<i>Ref.</i>	<i>Part Number</i>	<i>Qty.</i>	<i>Description</i>	<i>Ref.</i>	<i>Part Number</i>	<i>Qty.</i>	<i>Description</i>
1	116-9975	1	Weld, Motion Control, Rt	15	1-808280	2	Pin-Clevis 5/16 X 1 49/64
2	116-9974	1	Weld, Motion Control, Lt	16	1-806003	2	Hairpin-Cotter
3	1-803022	2	Setscrew-5/16-18 X 5/8	17	1-613089	2	Tab-Spring, Extension
4	126-2982-01	1	Weld, Speed Control	18	1-603693	2	Spring
5	1-603735	2	Bushing-Flanged	19	126-0610	2	Pin, Motion Control
6	103-0265	2	Spring, Neutral Return	20	126-8571	2	Swivel-Adjustable, Short
7	1-603737	2	Bolt-Neutral Return	21	1-413350	2	Link-Control, Speed
8	3256-23	9	Washer-5/16 SAE	22	3272-5	2	Pin-Cotter 3/32 X 1/2
9	3219-2	7	Nut-Hex 5/16-24	23	1-323245	1	Spring-Compression
10	3220-2	2	Nut-Jam 5/16-24	24	1-603903	1	Spacer
11	104-8300	6	Nut-Nyloc 5/16-18 Flg	25	103-3060	1	Knob-Tracking
12	32128-20	2	Nut-Whizlock 5/16-18	26	1-809056	2	Screw-Sh 5/16-18 X 1 3/8
13	322-5	2	Screw-HH 5/16-18 X 1	27	116-7918	1	Decal-Tracking Adjustment
14	1-303105	2	Yoke-Adjustable	28	302-19	2	Zerk-1/4-28 Str



## Fuel Assembly (continued)

<i>Ref.</i>	<i>Part Number</i>	<i>Qty.</i>	<i>Description</i>	<i>Ref.</i>	<i>Part Number</i>	<i>Qty.</i>	<i>Description</i>
1	135-2855	1	ASM, Fuel Tank 5 Gal	11	126-1679	1	Hose, Emissions
1:2	137-4119	1	Cap-Fuel, Ratcheting	12	98-2952	1	Fitting-Straight
1:3	114-0284	1	Grommet	13	119-8562	1	Hose-Fuel
1:4	119-3547	1	Valve-Vent, Fuel	20	2412-98	4	Clamp-Hose
1:5	46-6560	1	Bushing	21	1-603770	1	Valve-Fuel
1:6	109-9364	1	Fitting-Fuel (W/Line And Screen)	34	1-303335	1	Tie-Cable 7 15/16 (Large)
2	107-4543	2	Clamp	36	110-1876	1	Hose-Fuel
3	104-8300	2	Nut-Nyloc 5/16-18 Flg	38	109-0275	1	Hose-Fuel Line 32"
4	322-10	2	Screw-HH 5/16-18 X 2	39	1-643312	1	Clip-Loom

# Engine Assembly

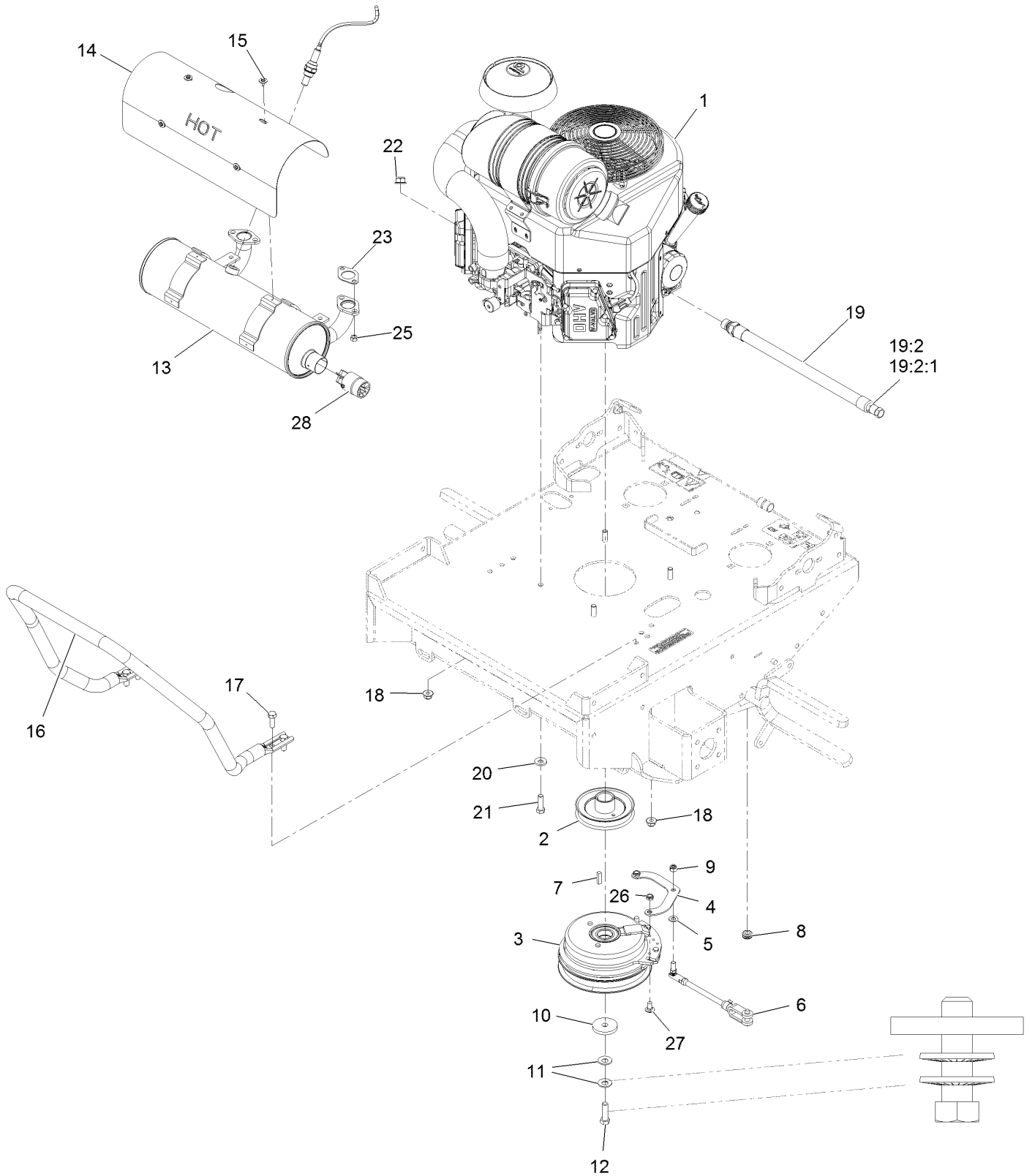



## Engine Assembly (continued)

<i>Ref.</i>	<i>Part Number</i>	<i>Qty.</i>	<i>Description</i>	<i>Ref.</i>	<i>Part Number</i>	<i>Qty.</i>	<i>Description</i>
1		1	Engine, Kohler Ecv650-3017 ▲◆	15	116-1103	4	Screw-HH, Thread Forming
2	126-2605	1	Sheave W/ Hub	16	135-4730-03	1	Tube-Guard Air Cleaner
3	126-2601	1	Clutch, 200 Ft/Lbs, 1.13	17	323-6	4	Screw-HH 3/8-16 X 1
4	126-2602	1	Strap, Clutch	18	104-8301	4	Nut-Nyloc 3/8-16 Flg
5	3256-23	1	Washer-5/16 SAE	19	116-5316	1	Oil Drain Hose ASM □■
6	126-0620	1	ASM, Clutch Anchor	19:2	353-508	1	Plug-W/O-Ring ●
7	1-807259	1	Key-Machine 1/4 X 1/4 X 1 ▶	19:2:1	237-42	1	O-Ring
8	237-136	1	Grommet	20	1-303334	4	Washer-Spring Disc 5/16
9	3296-4	1	Nut-Lock 5/16-24	21	322-7	4	Screw-HH 5/16-18 X 1 1/2
10	109-6919	1	Washer-Clutch	22	104-8300	4	Nut-Nyloc 5/16-18 Flg
11	1-603610	2	Washer-Spring Disc 7/16	23	110-6697	2	Gasket-Exhaust
12	87-2080	1	Bolt-Hex, TAP ○	25	68-9400	4	Nut-Flange
13	116-8653	1	Muffler-Ttx, EFI	26	3296-47	2	Nut-Nyloc 5/16-18 Thin
14	116-8654	1	Shield-Muffler,Ttx EFI	27	3230-18	2	Bolt-Carriage 5/16-18 X 5/8
				28	75-6880	1	Screen-Arrester, Spark

● Torque to 24-26 ft-lb

▲ Not serviced separately

□ Use a Teflon Pipe Sealant or equivalent on threads.

○ Use Pro-Lock, Nut Type (P/N 1-840022, .5ml tube) on threads.

▶ Apply anti-seize compound to engine crankshaft, pulley hub I.D., clutch bore I.D. and square key.

■ Torque to 17-23 ft-lb

◆ Obtain parts from [www.kohlerplus.com](http://www.kohlerplus.com)

# Hydro Assembly

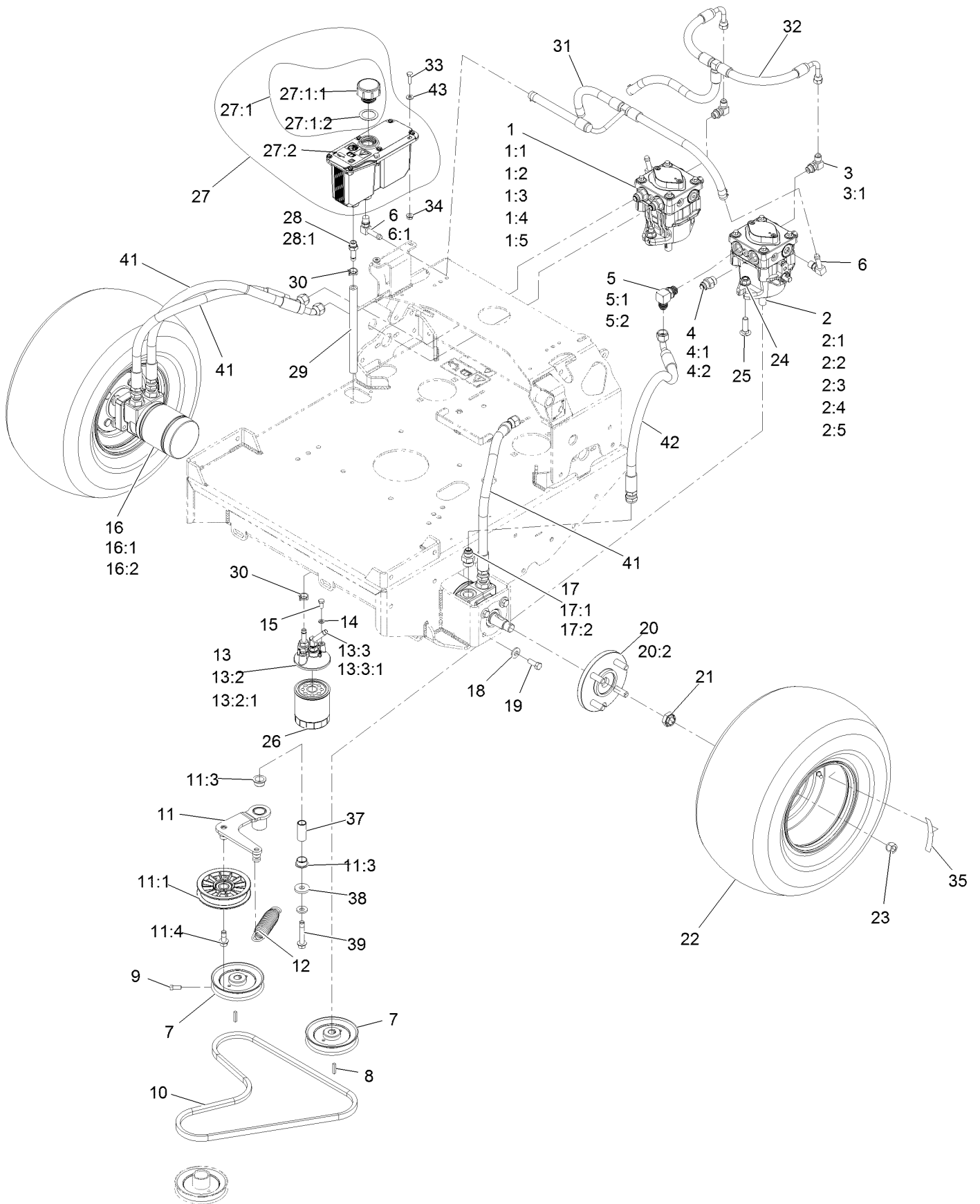

## Hydro Assembly (continued)

<i>Ref.</i>	<i>Part Number</i>	<i>Qty.</i>	<i>Description</i>	<i>Ref.</i>	<i>Part Number</i>	<i>Qty.</i>	<i>Description</i>
1	116-2495	1	Pump-HYD Pe RH TTH	16	1-603718	2	HYD Motor ASM
1:1	103-2664	1	Input Shaft Kit	16:1	1-000119	1	Seal Kit
1:2	94-6922	1	Bearing-Thrust	16:2	1-000138	1	Bearing And Seal Kit
1:3	103-2666	1	Cylinder Block Kit	17	1-603991	4	Adapter-Straight
1:4	105-6184	1	Seal Overhaul Kit	17:1	237-80	1	O-Ring
1:5	126-2479	1	Kit, 10Cc Pump Kit	17:2	1-603992	1	O-Ring-37 Flare #8
2	116-2494	1	Pump-HYD Pe LH TTH	18	98-5975	9	Washer-Spring Disc 3/8
2:1	103-2664	1	Input Shaft Kit	19	323-6	8	Screw-HH 3/8-16 X 1
2:2	94-6922	1	Bearing-Thrust	20	112-9049	2	Wheel Hub ASM
2:3	103-2666	1	Cylinder Block Kit	20:2	1-633926	4	Stud-Wheel
2:4	105-6184	1	Seal Overhaul Kit	21	116-2839	2	Nut-Lock
2:5	126-2479	1	Kit, 10Cc Pump Kit	22	103-1715	2	Tire And Wheel Assy
3	103-1802	2	Fitting-Elbow, 90 DEG	23	242-50	8	Nut-Lug 1/2-20
3:1	237-42	1	O-Ring	24	114-8417	4	Nut-HF, NI
4	1-603990	3	Adapter-Straight	25	3232-3	4	Bolt-Carriage 7/16-14 X 1 1/2
4:1	1-603920	1	O-Ring-SAE #8	26	109-4180	1	Element, Oil Filter
4:2	1-603992	1	O-Ring-37 Flare #8	27	126-1248	1	ASM, HYD Reservoir ■
5	103-2153	1	Elbow-90°	27:1		1	Reservoir-HYD ●
5:1	1-603920	1	O-Ring-SAE #8	27:1:1	103-1948	1	Cap-Reservoir, HYD
5:2	1-603992	1	O-Ring-37 Flare #8	27:1:2	103-1949	1	Gasket-Cap
6	100-4887	3	Fitting-Elbow, 90	27:2	115-4212	1	Decal-Warning
6:1	237-42	1	O-Ring	28	103-1912	1	Adapter-Straight
7	1-413010	2	Sheave ASM	28:1	237-42	1	O-Ring
8	1-807272	2	Key-5Mm X 5Mm X 25Mm	29	103-2959	1	Hose-Charge
9	120-6474	4	Screw-Set, SQH 5/16-18 X 3/4	30	103-1988	6	Clamp-Hose 11/16
10	103-4761	1	Belt	31	126-2550	1	Hose, Case
11	126-2531	1	ASM, Pump Idler	32	126-2555	1	Hose, Charge
11:1	109-4077	1	Pulley-Idler, Flat	33	321-5	2	Screw-HH 1/4-20 X 7/8
11:3	109-8054	2	Bushing-Flanged	34	32128-32	2	Nut-Hex 1/4-20 Side Lock
11:4	126-1680	1	Screw-Hfh	35	126-2056	2	Decal-Torque Wheel Lug-Hub
12	116-6316	1	Spring-Extension	37	126-2954	1	Pivot, Idler
13	126-0621	1	ASM, Filter Head	38	1-373034	1	Washer
13:2	103-1912	1	Adapter-Straight	39	126-2956	1	Screw-HHF
13:2:1	237-42	1	O-Ring	41	116-8646	3	Hose,Hydraulic W/Cover
13:3	103-1807	1	Fitting-Barbed, 45 DEG	42	119-7827	1	HYD Hose ASM
13:3:1	237-42	1	O-Ring	43	3256-22	2	Washer-1/4 SAE
14	1-805004	2	Washer-Lock 1/4 Heavy				
15	321-3	2	Screw-HH 1/4-20 X 5/8				

● Not serviced separately

■ Use Exmark Premium Hydro Oil P/N 109-9828 (32oz)

# Electrical Assembly

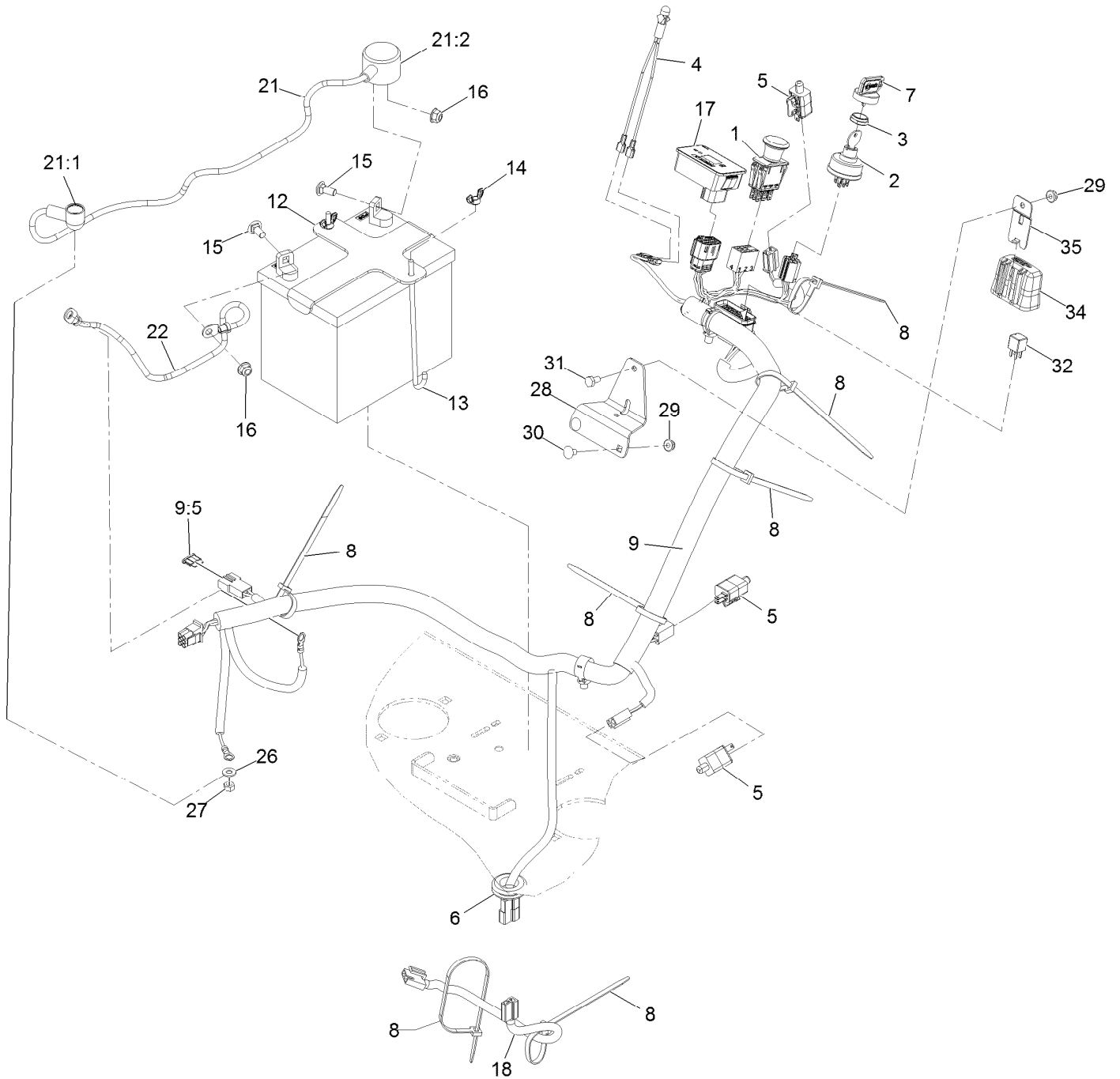

## Electrical Assembly (continued)

<i>Ref.</i>	<i>Part Number</i>	<i>Qty.</i>	<i>Description</i>	<i>Ref.</i>	<i>Part Number</i>	<i>Qty.</i>	<i>Description</i>
1	103-5221	1	Switch-PTO	18	126-0624	1	Harness-Clutch Pigtail
2	135-2253	1	Switch, Key Start	21	109-7621	1	Positive Battery Cable ASM
3	103-0498	1	Nut-Ignition	21:1	1-543393	1	Insulator-Solenoid
4	1-643267	1	Indicator-Red LED	21:2	109-2407	1	Insulator-Battery
5	110-6765	3	Switch	22	1-413540	1	Cable-Battery, Negative ●
6	1-543286	1	Grommet	26	3256-22	1	Washer-1/4 SAE
7	103-2106	1	Key-Exmark Logo	27	3217-5	1	Nut-Hex 1/4-20
8	1-303335	7	Tie-Cable 7 15/16 (Large)	28	126-6603-03	1	Bracket-Mounting, Fuseblock
9	126-6170	1	Harness-Wire ■	29	104-7201	3	Nut-Nyloc 1/4-20 Flg
9:5	1-816001	1	Fuse-Blade Type, 20 Amp	30	3229-10	2	Bolt-Carriage 1/4-20 X 1/2
12	135-2056	1	Bracket, Battery Hold Down	31	321-2	1	Screw-HH 1/4-20 X 1/2
13	1-633651	2	Bolt-Holddown	32	126-3991	1	Relay-Micro
14	1-543792	2	Wingnut-Nyloc 1/4-20	34	32180-176	1	Cover-Block, Fuse
15	3230-1	2	Bolt-Carriage 5/16-18 X 3/4	35	32180-177	1	Clip-Mounting
16	104-8300	2	Nut-Nyloc 5/16-18 Flg				
17	142-2440	1	Module-Hour Meter				

● Not illustrated

■ Use dielectric grease on all unsealed connectors and terminals only. Do not apply in sealed connectors.

**Notes:**



# MAXIMIZE THE PERFORMANCE OF YOUR EXMARK MACHINE.



## EXMARK® PREMIUM ENGINE OIL

Exmark now offers a family of engine oil viscosities to perform well in any environment. Each viscosity has the same synthetic formulation to give you what you need in punishing conditions. We designed each grade to the highest quality, making it ideal even for diesel applications. Coupled with Exmark Premium Fuel Treatment, we have the performance products to make your machine hum.

### EXMARK PREMIUM ENGINE OIL SAE 30/10W-30

- Meets zero shear requirements of a straight grade SAE 30 as well as the cold temp properties of a 10W-30.
- Most versatile oil in the industry.
- Superior corrosion protection over conventional oil - even in corrosive, humid environments.

### EXMARK PREMIUM ENGINE OIL SAE 20W-50

- Perfect for your big block engine, or any application in severe service.
- Same full synthetic formulation as all other Exmark Premium viscosities.
- Also effective for use in severe service small block engines.

### EXMARK PREMIUM ENGINE OIL SAE 10W-50

- Full synthetic formulation gives you peak performance. Don't settle for less.
- Wide span multi-grade combines easy starting in cold weather with maximum protection in high temperature operation.
- Reduce friction & wear over standard mineral formulations.

### EXMARK PREMIUM ENGINE OIL SAE 0W-40

- The perfect choice for when the weather turns cold or unpredictable, and your Exmark UTV has to perform.
- Commercial quality for severe service.
- Advanced additive package helps prevent corrosion from long-term storage.

### EXMARK PREMIUM ENGINE OIL UTV FORMULATION

- 4-cycle high-temp formulation.
- Heavier viscosity, full synthetic, perfect for your UTV.

### EXMARK PREMIUM UTV EXTREME CONDITIONS GEAR OIL

- SAE 80W-90, designed to keep your UTV performing at its peak.
- Shear stable, hypoid gear lube.
- Includes a premium additive system to combat wear, oxidation, rust & corrosion.

**Available from your local Exmark dealer. Find your closest dealer at [exmark.com](http://exmark.com)**

## EXMARK ACCESSORIES AND OPTIONS\*

### MID-MOUNT RIDING ACCESSORIES AND OPTIONS

CUSTOM RIDE SEAT SUSPENSION SYSTEM	OPERATOR CONTROLLED DISCHARGE
FULL SUSPENSION SEAT	SUN SHADE
DECK LIFT ASSIST KIT	TRASH CONTAINER
HITCH KIT	TURF STRIPER
LIGHT KIT	ULTRA VAC COLLECTION SYSTEM
12V POWER PORT	ULTRA VAC QUICK DISPOSAL SYSTEM
MICRO-MULCH SYSTEM	

### OUT-FRONT RIDING ACCESSORIES AND OPTIONS

CUSTOM RIDE SEAT SUSPENSION SYSTEM	SNOW BLADE
DUAL-TAIL WHEEL	SNOWBLOWER
FLOOR PAN EXTENDER	SUN SHADE
HITCH KIT	TRASH CONTAINER
LIGHT KIT	ULTRA VAC COLLECTION SYSTEM
MICRO-MULCH SYSTEM	ULTRA VAC QUICK DISPOSAL SYSTEM
ROLL OVER PROTECTION SYSTEM (ROPS)	WEATHER CAB

### WALK-BEHIND ACCESSORIES AND OPTIONS

GRASS CATCHER	TURF STRIPER
MICRO-MULCH SYSTEM	STANDON

\*Some accessories and options not available for some models.

Place Model No. and Serial No.  
Label Here (Included in the Literature  
Pack) or Fill in Below

Model No. \_\_\_\_\_

Serial No. \_\_\_\_\_

Date Purchased \_\_\_\_\_

Engine Model No. and Spec. No. \_\_\_\_\_

Engine Serial No. (E/No) \_\_\_\_\_

© 2020 Exmark Mfg. Co., Inc.  
2101 Ashland Ave  
Beatrice, NE 68310  
All Rights Reserved

Part No. 4504-590 Rev. B  
(402) 223-6375  
Fax (402) 223-5489  
Printed in the USA.

