

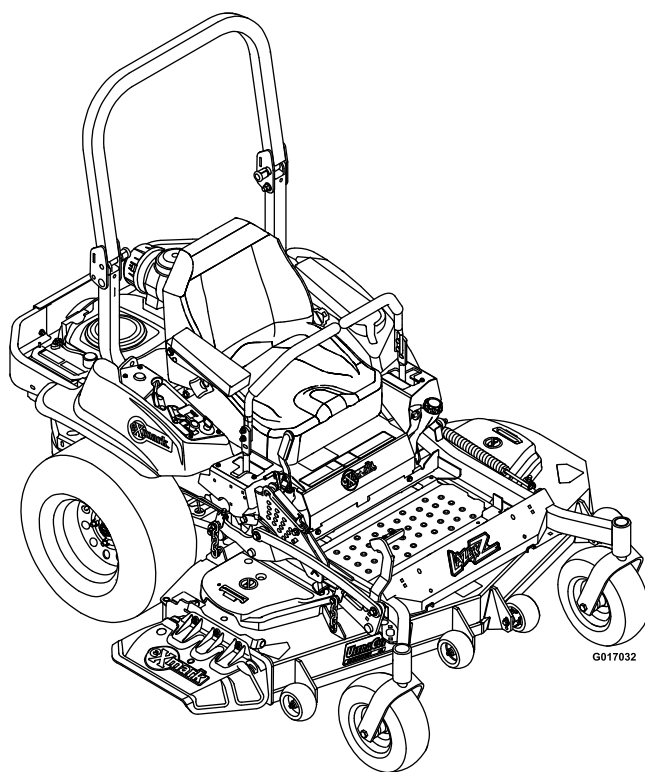

# LAZER Z<sup>®</sup> S-SERIES

Model No. LZS730EKC524—Serial No. 313000000 and Up

Picture below may not reflect actual product.



# Parts Manual

# Ordering Replacement Parts

To order replacement parts, please supply the part number, the quantity, and the description of each part desired.

## Understanding Reference Numbers

Each identified part in an illustration has a reference number. The reference number for a part also appears in the parts list, along with other information about the part.

This catalog uses two special reference number formats, one to indicate parts in a service assembly and another to indicate the quantity of a given part in an illustration.

## Service Assembly Reference Numbers

Parts in service assemblies have reference numbers in the form a:b. The a represents the reference number of the entire service assembly and the b represents a sequential number unique to each part within the service assembly.

For example, a wheel assembly might be identified by reference number 6, the tire by 6:1, the valve by 6:2, and the wheel by 6:3. When you order the assembly identified by reference number 6, you receive all parts identified by reference numbers 6:1, 6:2, and 6:3. However, you may also order any part individually. Reference numbers of this type appear in illustration and in parts lists.

## Reference Numbers Indicating Quantity

In an illustration, if a reference number indicates more than one part, the reference number has the form nX y. The n represents the quantity of the part, the X is the multiplication symbol, and the y represents the reference number.

For example, in an illustration, the reference number 2X 37 means that two of the parts identified by reference number 37 are indicated.

# List of Abbreviations

<b>AR:</b> as required	<b>HJ:</b> hex jam	<b>PRH:</b> phillips round head
<b>ASM:</b> assembly	<b>HLH:</b> hex lag head	<b>PTH:</b> phillips truss head
<b>BBC:</b> blade brake control	<b>HOC:</b> height-of-cut	<b>PTO:</b> power-take-off
<b>BHTF:</b> button head thread forming	<b>HSBH:</b> hex socket button head	<b>RH:</b> right hand
<b>CARR:</b> carriage	<b>HSFH:</b> hex socket flat head	<b>ROPS:</b> roll-over protection system
<b>CCW:</b> counter clockwise	<b>HSH:</b> hex socket head	<b>RRB:</b> rear roller brush
<b>CW:</b> clockwise	<b>HWH:</b> hex washer head	<b>SFH:</b> slotted fillister head
<b>DEG:</b> degrees	<b>HWHTF:</b> hex washer head thread forming	<b>SHH:</b> slotted hex head
<b>DPA:</b> Dual Point Adjustment	<b>HYD:</b> hydraulic	<b>SHWH:</b> slotted hex washer head
<b>ECM:</b> electronic control module	<b>LH:</b> left hand	<b>SPH:</b> slotted pan head
<b>EXT:</b> external	<b>LP:</b> Liquefied Petroleum Gas	<b>SQH:</b> square head
<b>FH:</b> flat head	<b>LPG:</b> Liquefied Petroleum Gas	<b>SRH:</b> slotted round head
<b>GA:</b> gauge	<b>NI:</b> nylon insert	<b>STD:</b> standard
<b>HD:</b> heavy-duty	<b>NPTF:</b> national pipe thread fine	<b>TAP:</b> self tapping
<b>HF:</b> hex flange	<b>PFH:</b> phillips flat head	<b>TTH:</b> torx truss head
<b>HH:</b> hex head	<b>PPH:</b> phillips pan head	
<b>HHF:</b> hex head flange	<b>PPHTF:</b> phillips pan head thread forming	
<b>HHFTF:</b> hex head flange thread forming		

# Touch Up Paint

Exmark black touch up spray paint – gloss black.

Exmark red touch up paint (spray paint – P/N 1-850337 - .6 oz liquid bottle – P/N 103-9140).



If your Exmark dealer does not have the Exmark part in stock, Exmark will get the parts to the dealer the next business day or the part will be FREE Guaranteed!! (Some restrictions apply. See your participating Exmark Dealer for details.)

## Contents

Complete Deck Assembly.....	4
Deck Assembly.....	5
Deck W/Decals Assembly No. 109-9149.....	6
Deck Idler Assembly No. 116-3755.....	7
Main Frame Assembly.....	8
Roll-Over Protection System Assembly No. 116-0230.....	9
Caster Wheel and Fork Assembly.....	10
Deck Lift Assembly.....	11
Height-of-Cut Assembly No. 109-7438.....	12
Controls Assembly.....	13
Motion Control Assembly.....	14
Rear Wheel and Park Brake Assembly.....	15
Parking Brake Handle Assembly No. 116-7551.....	16
Seat Assembly.....	17
Seat W/Tracks Assembly No. 116-4474.....	18
Fuel Tank Mounting Assembly.....	19
Fuel Tank Assembly No. 116-3979.....	20
Engine Assembly.....	21
Hydraulic Assembly.....	22
LH Hydro Assembly No. 116-6411.....	23
RH Hydro Assembly No. 116-6412.....	24
Pump Idler Assembly No. 116-1255.....	25
Electrical Assembly.....	26

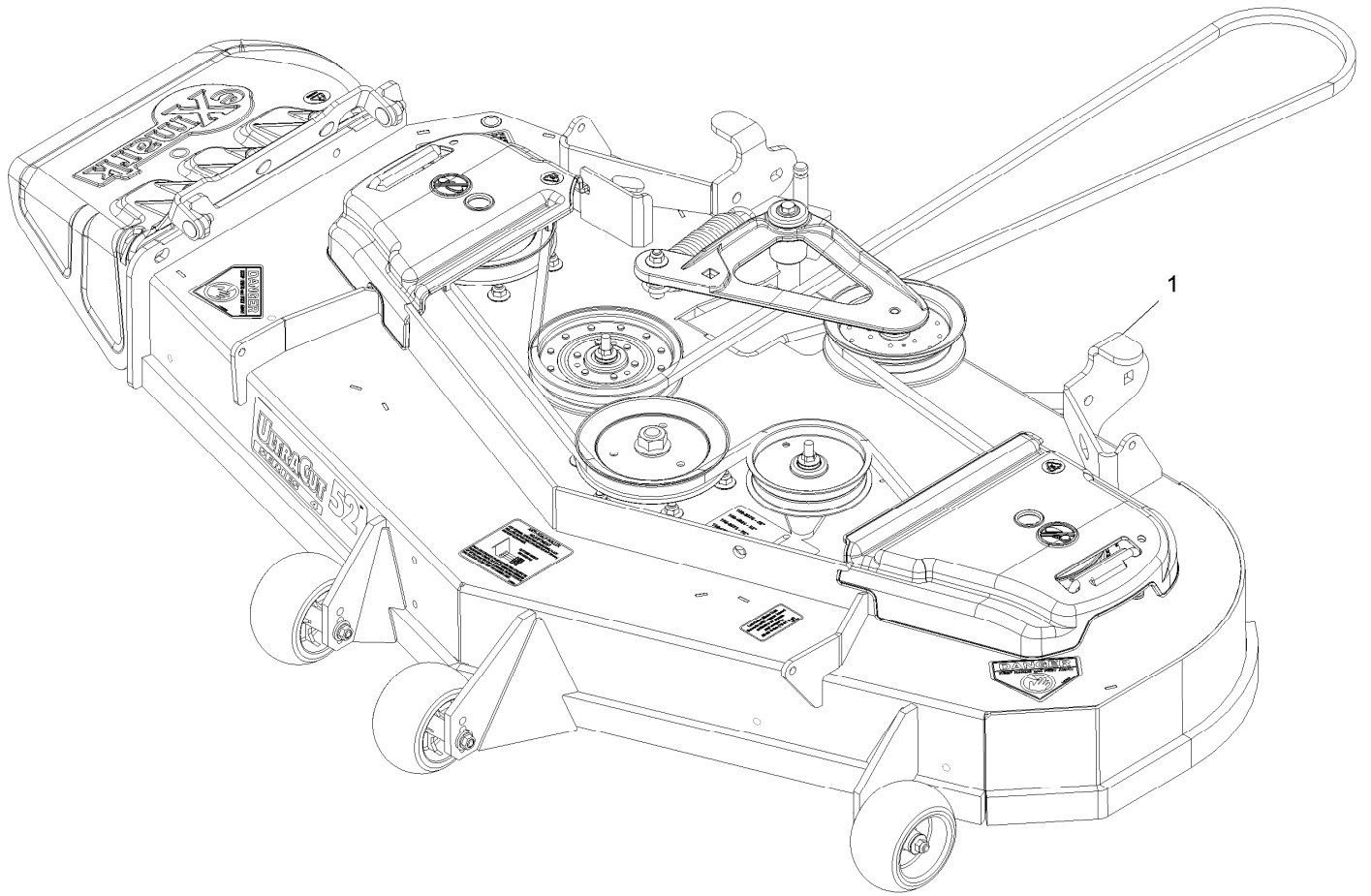

## Complete Deck Assembly

<i>Ref.</i>	<i>Part Number</i>	<i>Qty.</i>	<i>Description</i>
1	116-3598	1	ASM,524 Deck Complete

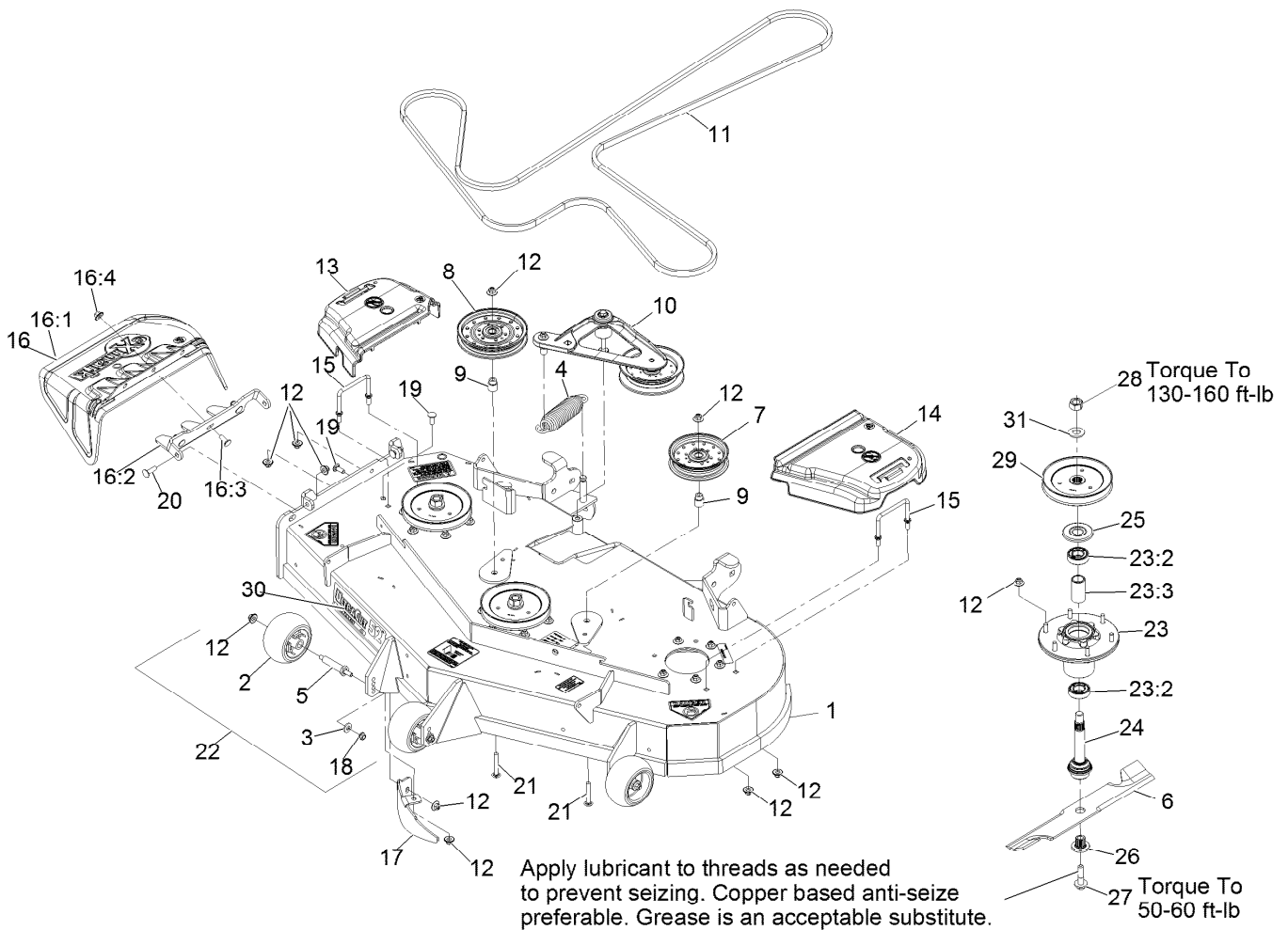

## Deck Assembly

Ref.	Part Number	Qty.	Description	Ref.	Part Number	Qty.	Description
1	109-9149	1	ASM,Deck W/ Decals 52	16:1	109-2738	1	Chute,Discharge
2	1-603299	3	Roller-Scalp, Anti	16:2	109-8675-01	1	Bracket,Discharge Chute
3	98-5975	3	Washer-Spring Disc 3/8	16:3	3231-22	3	Bolt-Carriage 3/8-16 X 1
4	116-6317	1	Spring-Extension	16:4	109-6658	3	Nut-Nyloc 3/8-16 Flg
5	99-2842	3	Spacer	17	116-5814-01	1	Baffle-Dogleg, Lz-Vt52
6	103-6392	3	Blade, Mulch 18.0 (.94 Hole)	18	3290-357	3	Nut-Whizlock 3/8-16
6	103-6387	3	Blade, Low Lift 18.0 (.94 Hole)	19	3231-22	2	Bolt-Carriage 3/8-16 X 1
6	103-6382	3	Blade, Solid 18.0 (.94 Hole)	20	3231-28	2	Bolt-Carriage 3/8-16 X 1 1/4
6	103-6402	3	Blade-Notched	21	3231-44	2	Bolt-Carriage 3/8-16 X 2 1/2
6	116-5175	3	Blade-Extreme 2, 18.00"	22	103-4051	3	Kit,Anti-Scalp Roller
7	116-4665	1	Idler-Pulley, Flat	23	116-3344	3	ASM-Cutter Hsg With Bearings
8	116-4667	1	Idler-Pulley, Flat	23:2	116-0720	2	Bearing-Ball
9	1-633456	2	Bushing,Idler	23:3	116-3312	1	Spacer-Bearing
10	116-3755	1	Deck Idler ASM	24	116-3341	3	ASM-Spindle And Seal
11	109-4994	1	Belt,V-B X 186.00"	25	116-1286	3	Guard,Bearing Top .989
12	109-6658	31	Nut-Nyloc 3/8-16 Flg	26	103-3037	3	Bushing,Splined
13	109-6935	1	Cover-Belt, RH	27	109-9220	3	Screw-Sems 1/2-20 X 2.19
14	109-6936	1	Cover-Belt, LH	28	116-7306	3	Nut-Hex
15	109-6982	2	Wireform-Cover	29	116-0675	3	Sheave,Blade Drive 6.50
16	109-7188	1	ASM,Discharge Chute	30	116-0034	1	Decal,Ultracut 52 Series 4
				31	103-2802	3	Washer-Spring Disc 3/4

● Requires installation of mulch kit for proper mulching. See your Exmark dealer for details.

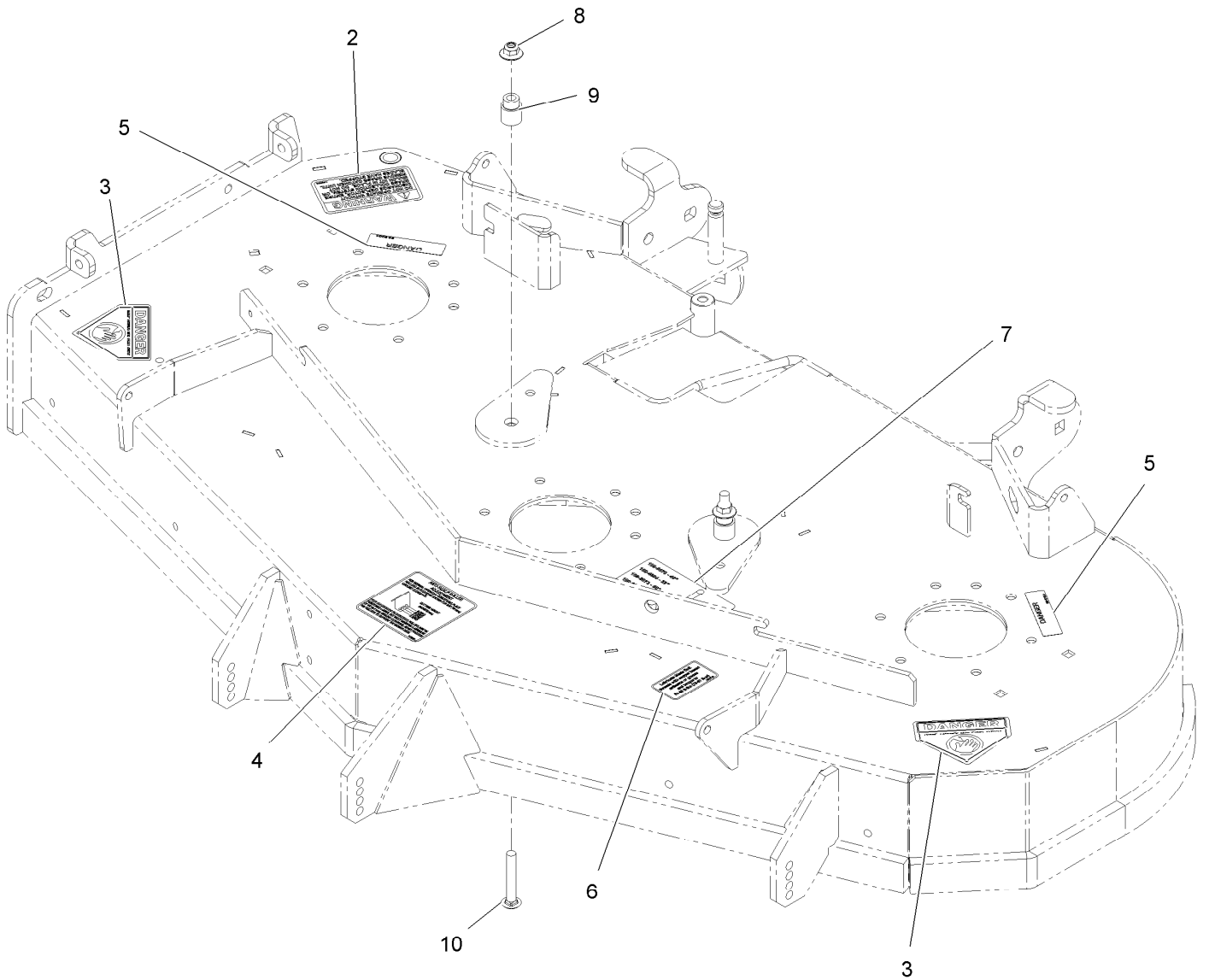

## Deck W/Decals Assembly No. 109-9149

Ref.	Part Number	Qty.	Description
2	1-303508	1	Decal-Warning, Discharge
3	1-403005	2	Decal-Danger
4	1-633922	1	Decal,Antiscalp
5	98-5954	2	Decal-Cover, Missing
6	109-3148	1	Decal,Bolt Torque
7	109-9361	1	Decal,Belt Routing
8	109-6658	2	Nut-Nyloc 3/8-16 Flg
9	1-633456	2	Bushing,Idler
10	3231-44	2	Bolt-Carriage 3/8-16 X 2 1/2



## Deck Idler Assembly No. 116-3755

<i>Ref.</i>	<i>Part Number</i>	<i>Qty.</i>	<i>Description</i>
1	43-0940	1	Spacer
2	103-2916	1	Guard-Top
3	103-3504	2	Bearing-Spherical
4	103-3505	1	Seal-Double Lip
5	103-3506	1	Seal-Single Lip
6	116-4668	1	Idler-Pulley, Flanged
7	106-7159	2	O-Ring
9	116-3467	1	Pin-Spring, Anchor
10	109-6658	2	Nut-Nyloc 3/8-16 Flg
11	109-7409	1	Screw-Shoulder 3/8-16 X 5
12	323-8	1	Screw-HH 3/8-16 X 1 1/2
13	32120-10	2	Ring-Retaining
14	302-19	1	Zerk-1/4-28 Str

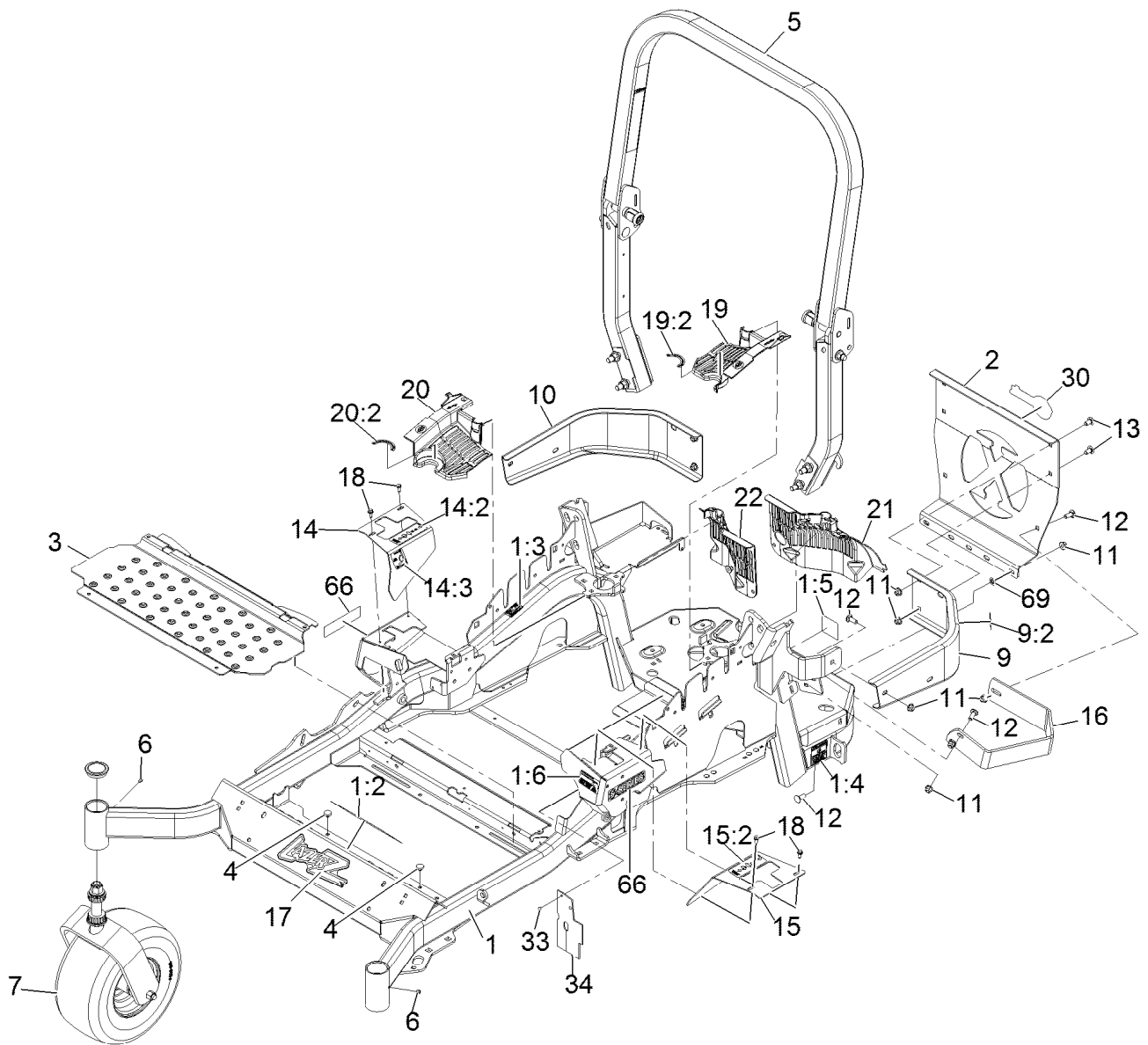

## Main Frame Assembly

Ref.	Part Number	Qty.	Description	Ref.	Part Number	Qty.	Description
1	116-5900	1	Mainframe ASM	14:2	109-7232	1	Decal-Motion Control
1:2	116-3303	1	Decal-Slope	14:3	116-5944	1	Decal-Park Brake
1:3	103-2076	2	Decal-Caution	15	116-0580	1	LH Motion Control Cover ASM
1:4	116-0205	2	Decal-Belt Drive	15:2	109-7232	1	Decal-Motion Control
1:5	116-4858	1	Decal-Spark Arrester	16	116-0043-03	1	Guard-Muffler
1:6	116-1654	1	Decal-Fuel Fill	17	103-3113	1	Decal,Lazer Model
2	109-8863-03	1	Plate,Rear Guard	18	32144-10	4	Screw-HWH 1/4-20 X .62
3	116-8898-01	1	Floorpan	19	116-0170	1	LH Hydro Guard ASM
4	1-513658	2	Bumper	19:2	116-0157	1	Decal-Hydro Oil
5	116-0230	1	ASM,ROPS Service Exmark	20	116-0171	1	RH Hydro Guard ASM
6	1-811010	2	Plug	20:2	116-0157	1	Decal-Hydro Oil
7		2	ASM,Front Caster W/Fork ●	21	109-9057	1	Guard-Hydro, Rear LH
9	116-0180	1	LH Bumper ASM	22	109-9058	1	Guard-Hydro, Rear RH
9:2	103-2076	1	Decal-Caution	30	103-2883	1	Decal
10	116-0057-03	1	Bumper-RH	33	1-803035	2	Rivet 3/16 X 1/4
11	104-8301	11	Nut-Nyloc 3/8-16 Flg	34	116-2362	1	Deflector-Air Flow
12	3231-22	7	Bolt-Carriage 3/8-16 X 1	66	116-3884	2	Decal-S-Series
13	3231-21	4	Bolt-Carriage 3/8-16 X 3/4	69	107-3154	2	Nut-Push 3/8-16
14	116-5899	1	RH Motion Control Cover ASM				

● Not serviced separately



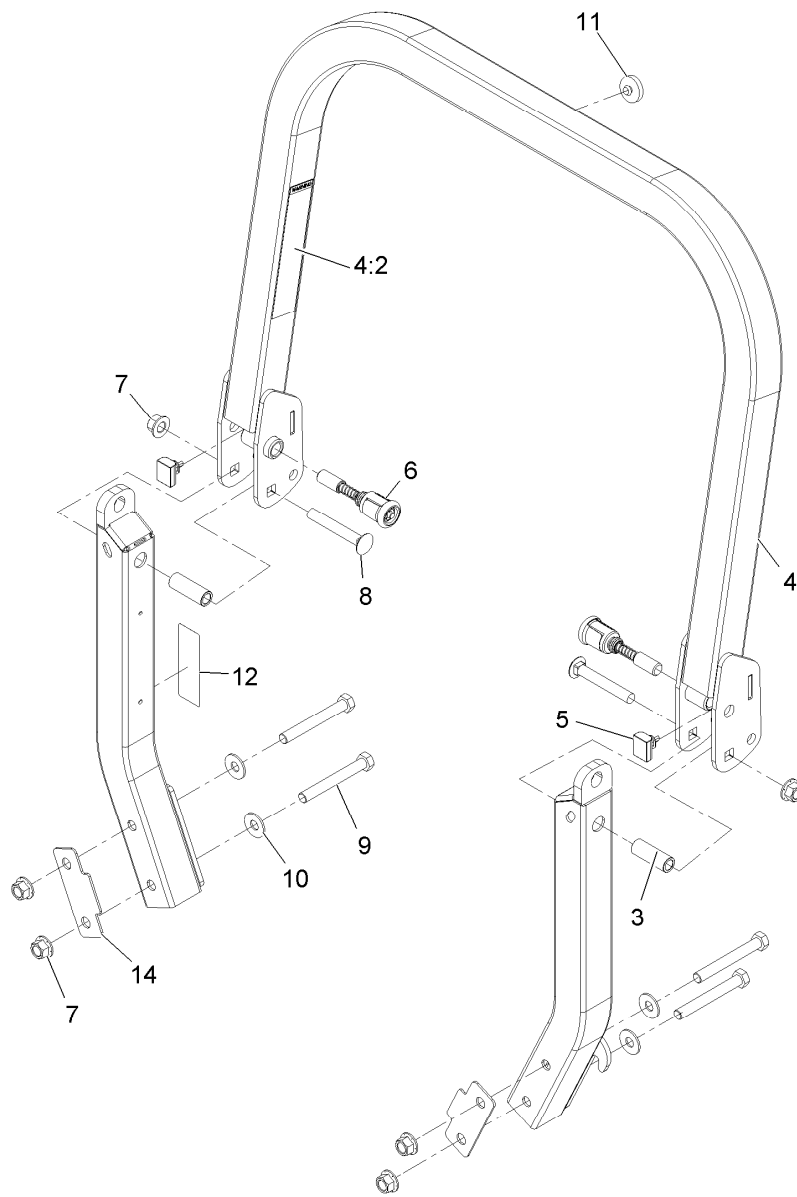

## Roll-Over Protection System Assembly No. 116-0230

<i>Ref.</i>	<i>Part Number</i>	<i>Qty.</i>	<i>Description</i>
3	109-6653	2	Spacer
4	116-0019	1	Upper ROPS ASM
4:2	107-2102	1	Decal-Warning, Folding ROPS
5	109-5337	2	Bumper-ROPS
6	116-0104	2	Spring Pin ASM
7	99-5107	6	Nut-Lock 1/2-13
8	3233-10	2	Bolt-Carriage 1/2-13 X 3 1/2
9	325-17	4	Screw-HH 1/2-13 X 4
10	109-9505	4	Washer-Spring
11	109-9233	1	Bumper-Push-In, Rubber
12	116-0090	1	Decal-Caution
14	116-0960	2	Spacer

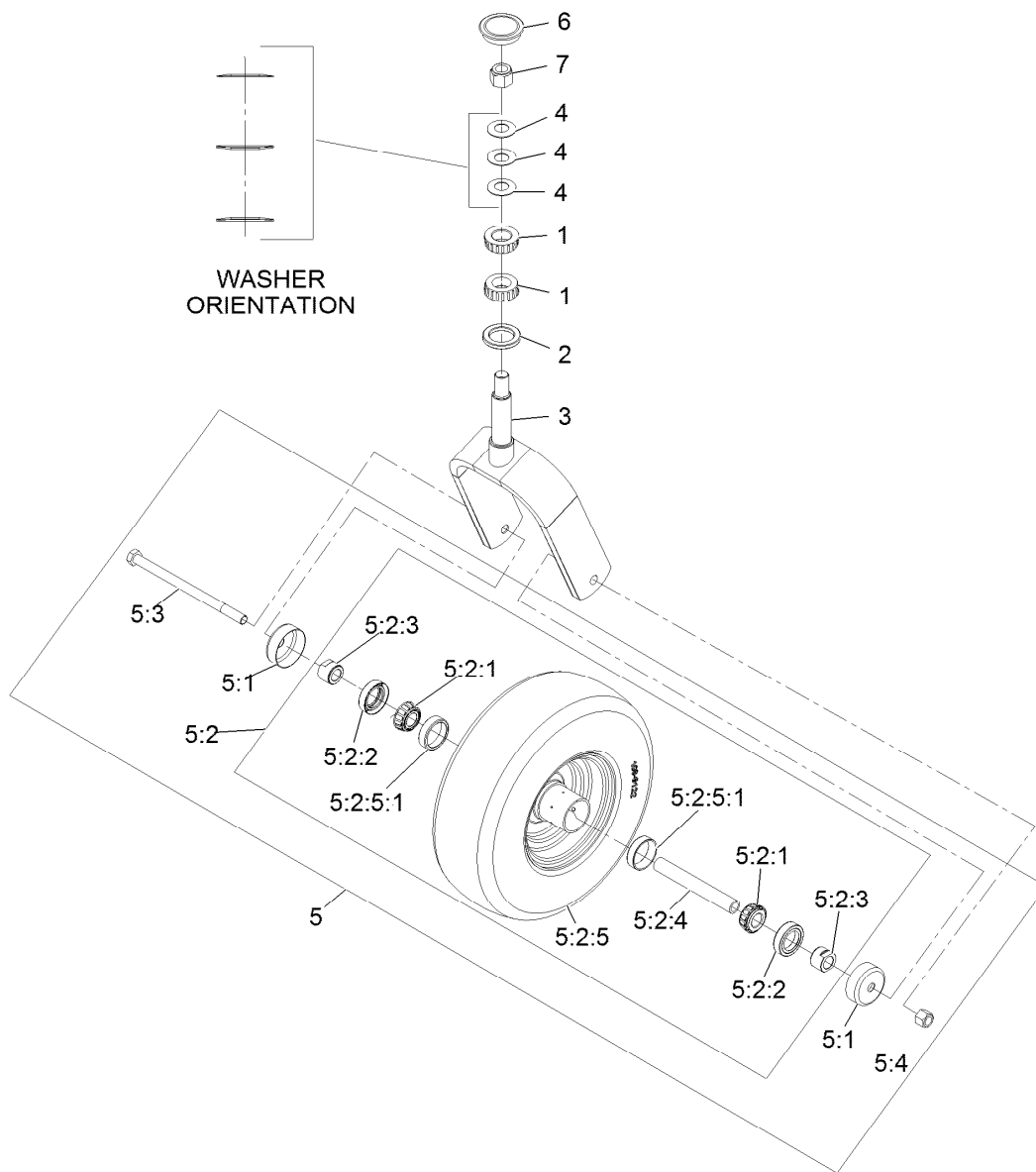

## Caster Wheel and Fork Assembly

Ref.	Part Number	Qty.	Description	Ref.	Part Number	Qty.	Description
1	1-543509	2	Bearing-Roller, Tapered	5:2:3	103-3051	2	Spacer-Nut ■
2	116-5647	1	Seal-Grease	5:2:4	103-3155	1	Axle-Caster
3	116-6703-01	1	Weld, Fork	5:2:5		1	Wheel And Tire ASM ●
4	1-633508	3	Washer-Bellville	5:2:5:1	1-633584	1	Bearing-Cup
5	109-9126	1	Wheel And Tire ASM	5:3	325-42	1	Screw-HH
5:1	103-2768	2	Guard-Seal	5:4	3296-23	1	Nut-Lock, NI
5:2		1	Wheel And Tire ASM ●	6	103-4882	1	Cap-Grease
5:2:1	1-633585	2	Bearing-Cone, Taper	7	3296-51	1	Nut-Lock, NI
5:2:2	103-0063	2	Seal-Caster				

● Not serviced separately

■ Use Pro-Lock, Nut Type (P/N 1-840022, .5ml tube) on threads.

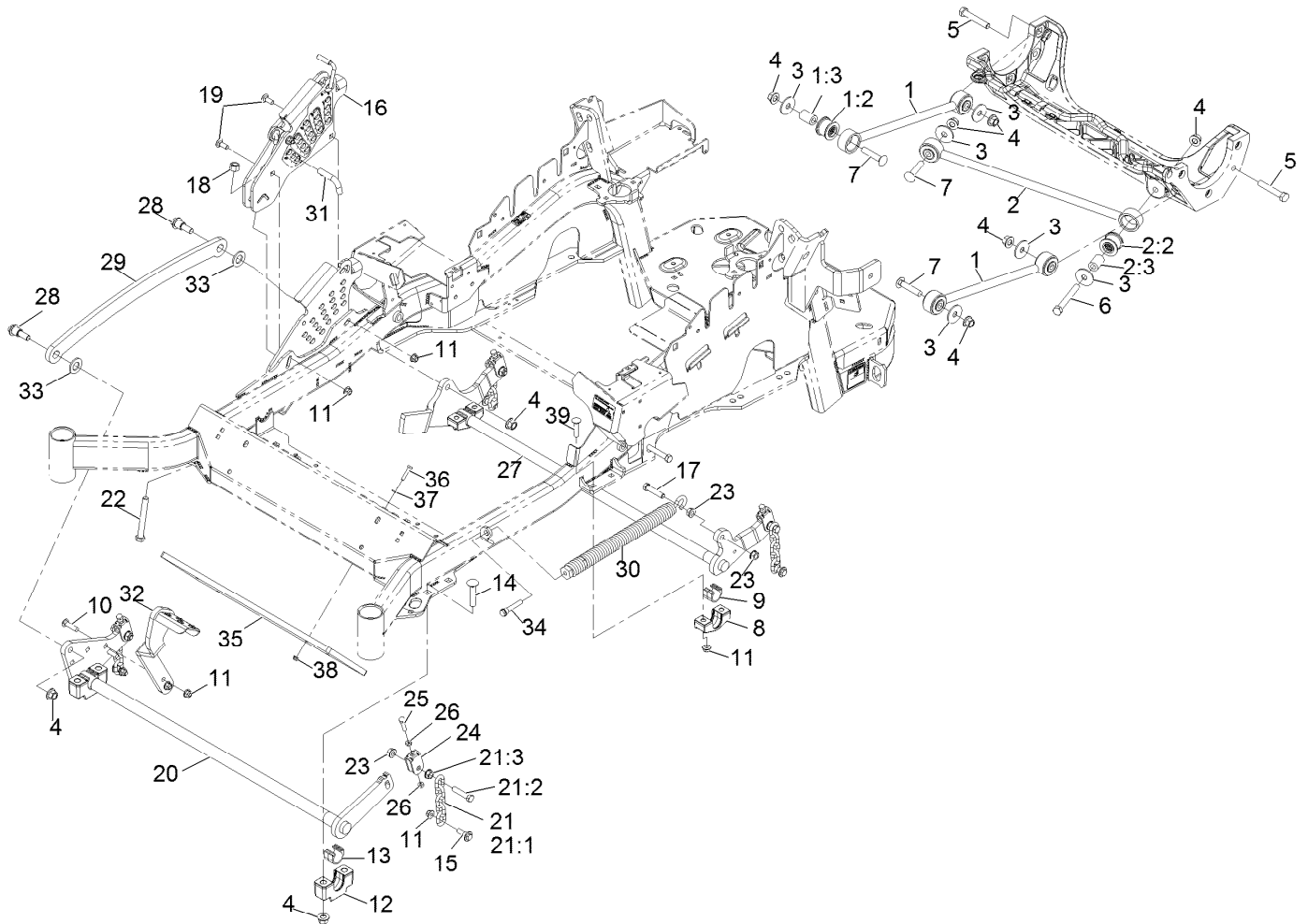

## Deck Lift Assembly

Ref.	Part Number	Qty.	Description	Ref.	Part Number	Qty.	Description
1	109-7952	2	Deck Strut ASM	18	3296-23	1	Nut-Nyloc 1/2-13
1:2	109-5009	2	Bushing-Suspension, Rubber	19	3231-2	2	Bolt-Carriage 3/8-16 X 1
1:3	109-5010	2	Spacer	20	116-2217-03	1	Front Cross Shaft ASM
2	109-5013	1	Panhard Rod ASM	21	116-0756	4	Deck Lift Chain ASM
2:2	109-5009	2	Bushing-Suspension, Rubber	21:1	1-633447	1	Chain-Lift, Deck
2:3	109-5010	2	Spacer	21:2	109-9065	1	Screw-HH 7/16-14 X 2
3	86-1990	6	Washer	21:3	32128-37	1	Nut-Whizlock 7/16-14
4	99-5107	12	Nut-Lock 1/2-13	22	116-0559	1	Bolt-HH 1/2-13 X 4 Tap
5	325-12	2	Screw-HH 1/2-13 X 3	23	32128-37	6	Nut-Whizlock 7/16-14
6	325-17	1	Screw-HH 1/2-13 X 4	24	109-9066	4	Yoke-Adjust, Deck
7	3233-34	3	Bolt-Carriage 1/2-13 X 2 1/2	25	322-47	4	Screw-HH
8	116-0818-03	2	Support-Cross Shaft, Rear Bearing	26	3218-2	8	Nut-Jam 5/16-18
9	109-7173	2	Bearing-Cross Shaft, Rear	27	116-0459-03	1	Lift-Deck, Rear
10	3231-4	2	Bolt-Carriage 3/8-16 X 1 1/2	28	116-0780	2	Screw-Shoulder HHF 1/2-13 X 1.12
11	104-8301	12	Nut-Nyloc 3/8-16 Flg	29	116-0797-03	1	Link-Lift, Deck
12	109-9409	2	Support-Cross Shaft, Front Bearing	30	116-0886	1	Extension Spring ASM
13	109-9410	2	Bearing-Cross Shaft, Front	31	116-5584	1	Pin-HOC
14	116-1700	4	Bolt-Carriage 1/2-13 X 2 1/2 Spl Neck	32	116-1919-01	1	Lever-Foot
15	109-9840	4	Screw-Hex Flange 3/8-16 X .80	33	3256-28	2	Washer-3/4 Sae
16	109-7438	1	HOC ASM	34	92-7674	1	Screw-Shcs 3/8-16 X 2.212
17	109-9065	1	Screw-HH 7/16-14 X 2	35	116-0827-01	1	Weight, Toe Board
				36	321-8	4	Screw-HH 1/4-20 X 1 1/4
				37	3256-22	4	Washer-1/4 Sae
				38	104-7201	4	Nut-Nyloc 1/4-20 Flg
				39	3231-5	4	Bolt-Carriage 3/8-16 X 1 3/4

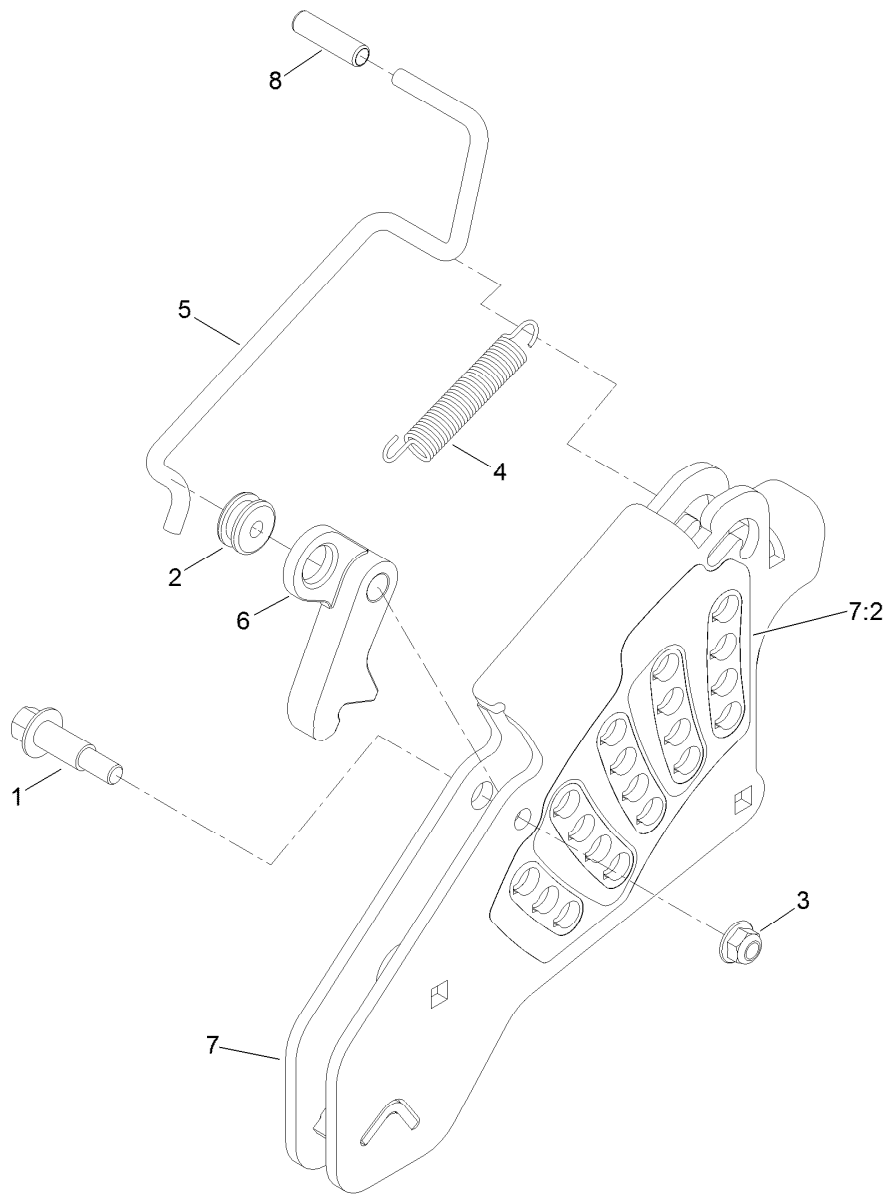

## Height-of-Cut Assembly No. 109-7438

<i>Ref.</i>	<i>Part Number</i>	<i>Qty.</i>	<i>Description</i>
1	62-1330	1	Bolt-Shoulder
2	109-7130	1	Grommet
3	104-8301	1	Nut-Flange, NI
4	109-7124	1	Spring-Extension
5	109-7128	1	Rod-Lock, Transport
6	116-0118	1	Pawl-Transport, HOC
7	109-7335	1	HOC Plate ASM
7:2	116-0752	1	Decal-HOC
8	109-8250	1	Grip-Lever

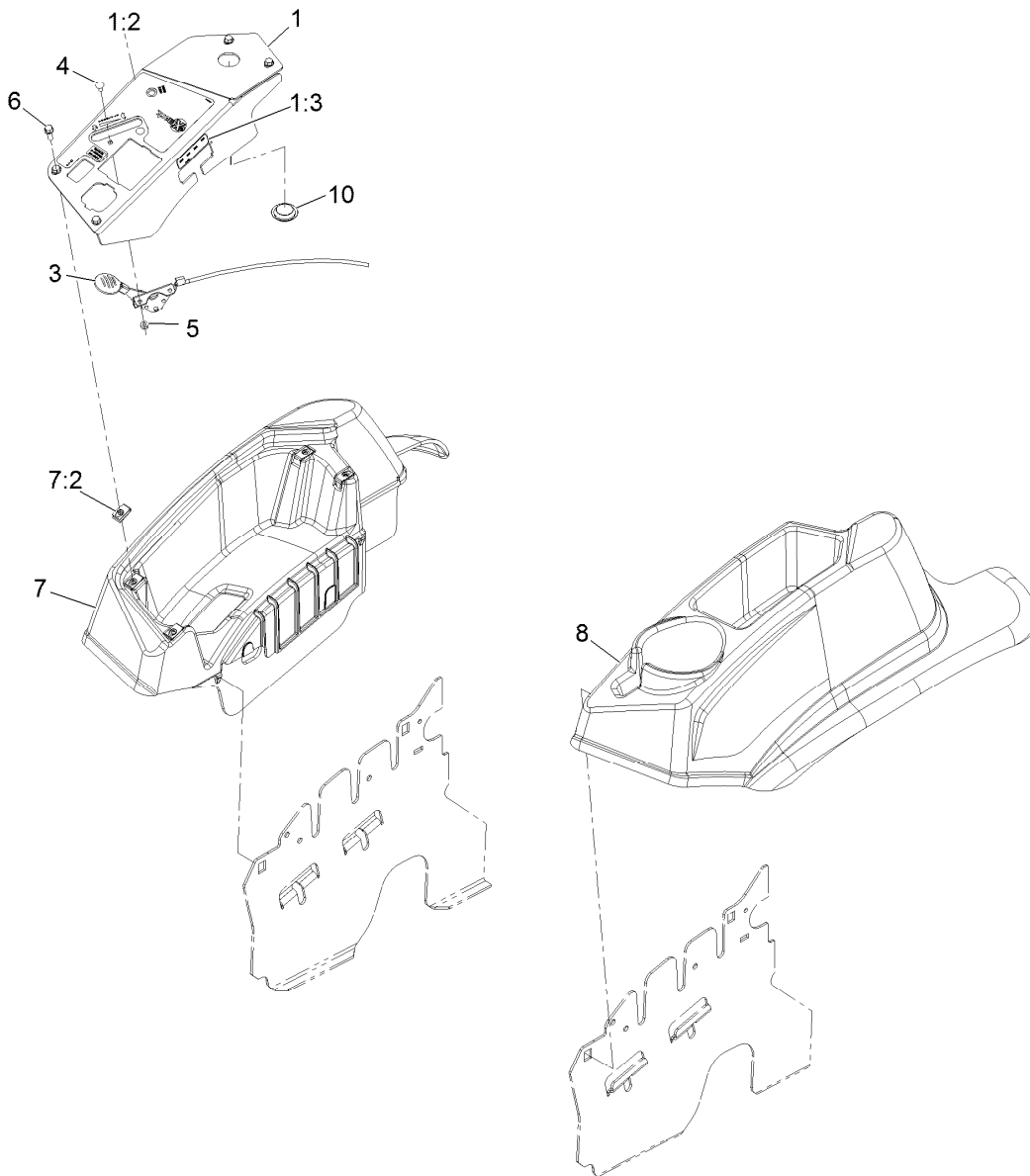

## Controls Assembly

<b>Ref.</b>	<b>Part Number</b>	<b>Qty.</b>	<b>Description</b>
1	116-2845	1	ASM,Control Panel W/Decal
1:2	116-2844	1	Decal,Control Panel Efi
1:3	109-7330	1	Decal-Fuse
3	116-0969	1	ASM,Throttle Cable
4	1-807513	2	Bolt-Carriage #10-24 X 1/2
5	3296-2	2	Nut-Nyloc #10-24
6	32105-15	4	Screw-Machine 1/4-20 X 3/4
7	116-1278	1	Console,RH As ASM
7:2	107069	4	Nut-Retainer-Panel 1/4-20
8	109-9457	1	Console, LH As
10	116-1875	1	Plug,Plastic

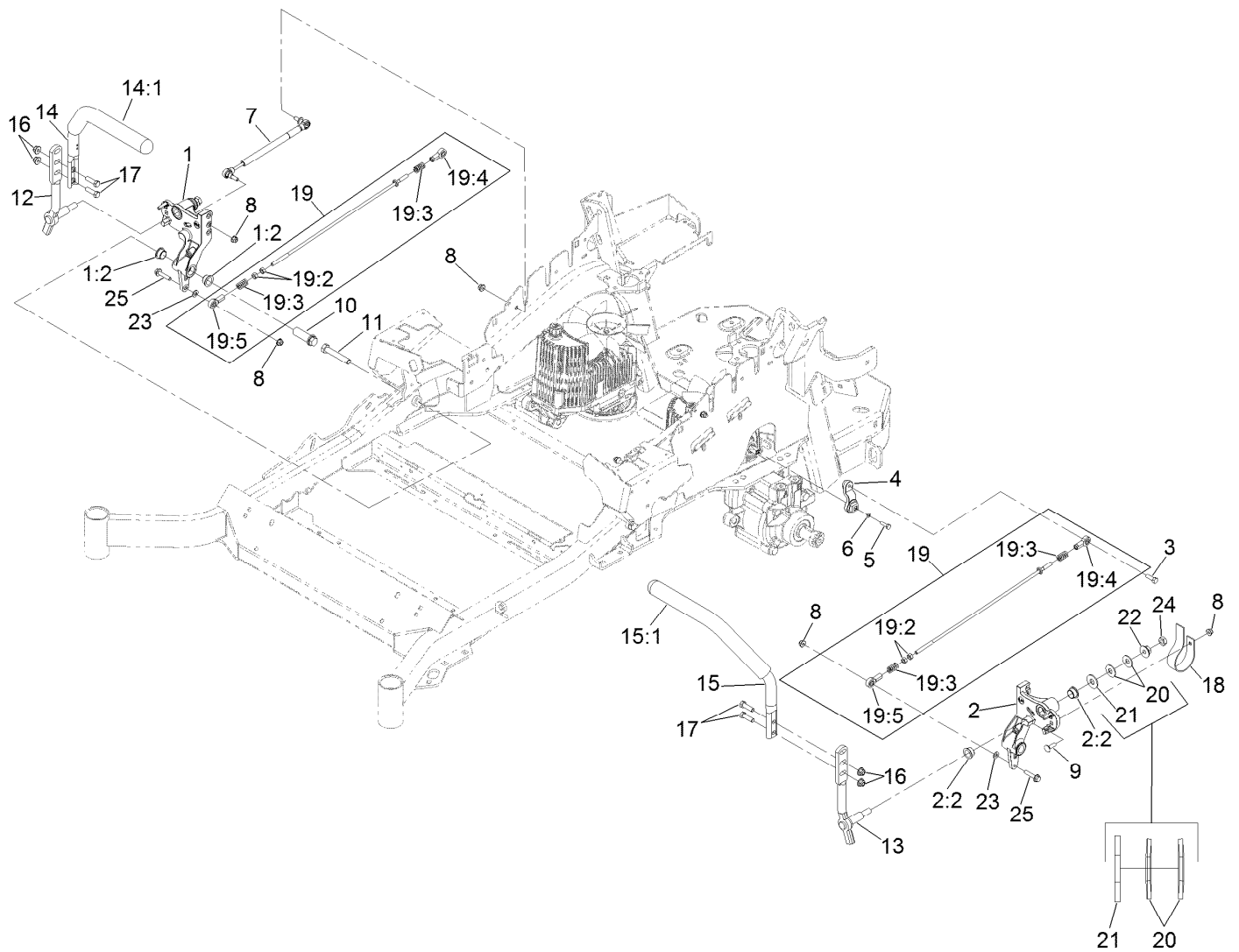

## Motion Control Assembly

Ref.	Part Number	Qty.	Description	Ref.	Part Number	Qty.	Description
1	116-0880	1	RH Motion Control And Bushing ASM	14	109-6589	1	RH Steering Handle ASM
1:2	109-8054	4	Bushing-Flange	14:1	109-5668	1	Grip-Control, Lever
2	116-0881	1	LH Motion Control And Bushing ASM	15	109-6590	1	LH Steering Handle ASM
2:2	109-8054	4	Bushing-Flange	15:1	109-5668	1	Grip-Control, Lever
3	116-0648	2	Screw-HH, Thread Locking ●	16	104-8301	4	Nut-Flange, NI
4	109-4581	2	Arm-Control, Pump	17	323-7	4	Screw-HH
5	9080046	2	Screw-HH ●	18	109-5575	2	Spring-Leaf
6	1-303435	2	Washer-Spring	19	109-8107	2	Pump Linkage Rear ASM
7	116-0027	2	Damper-Control, Motion	19:2	3219-2	2	Nut-Hex
8	104-8300	8	Nut-Flange, NI	19:3	1-323245	2	Spring-Compression
9	3230-2	2	Bolt-CARR	19:4	1-633152	1	Balljoint-LH
10	109-5891	2	Hub-Threaded	19:5	1-543017	1	Balljoint-RH
11	325-12	2	Screw-HH	20	109-9505	4	Washer-Spring
12	116-0039	1	Lever-Control Motion, RH	21	3256-6	2	Washer-Flat
13	116-0040	1	Lever-Control Motion, LH	22	32128-56	2	Nut-HF
				23	3256-23	2	Washer-Flat
				24	3218-5	2	Nut-Jam
				25	115-1794	2	Screw-HHF

● Use Pro-Lock, Nut Type (P/N 1-840022, .5ml tube) on threads.

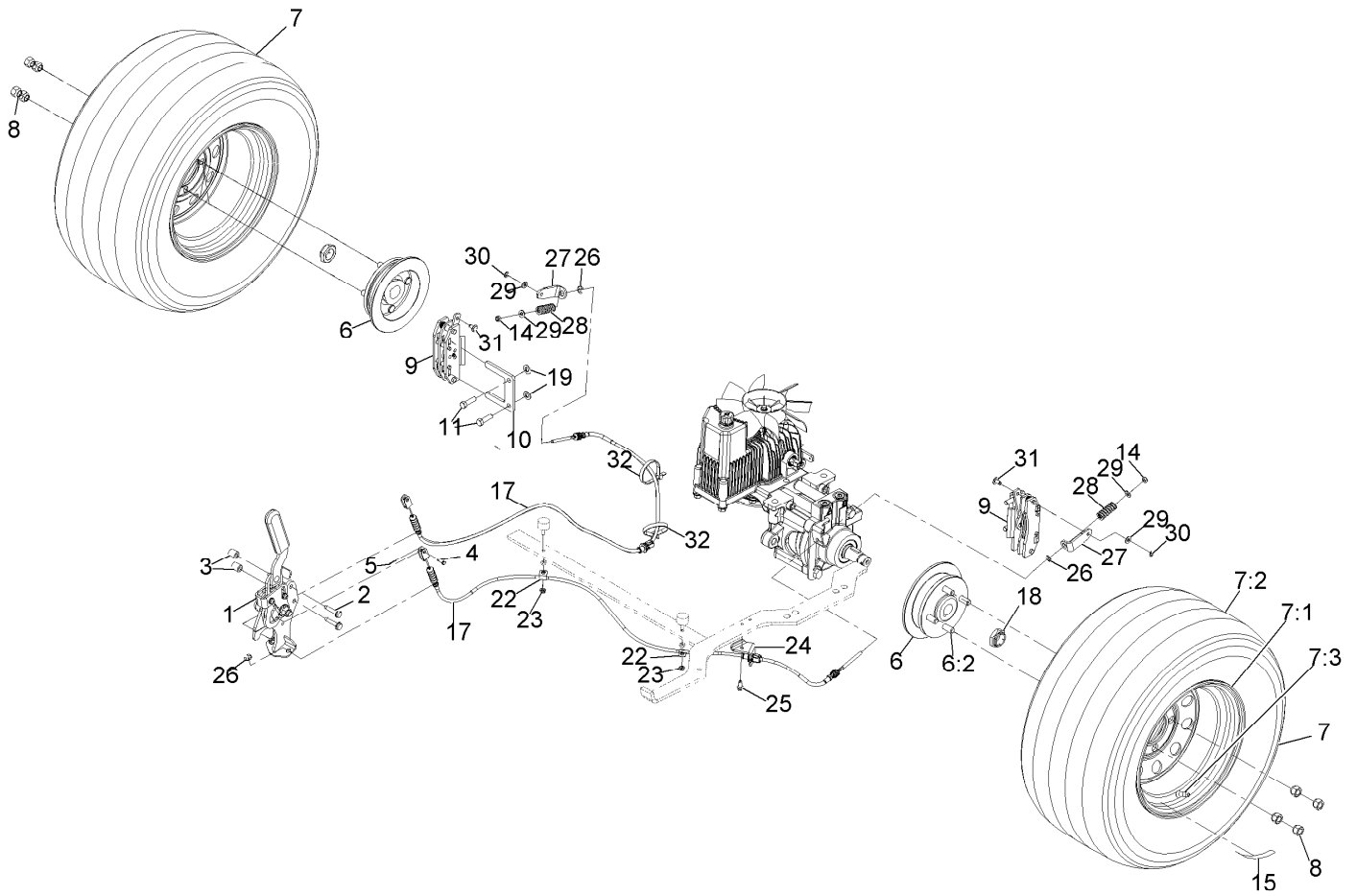

## Rear Wheel and Park Brake Assembly

Ref.	Part Number	Qty.	Description	Ref.	Part Number	Qty.	Description
1	116-7551	1	Brake Handle ASM	14	3296-13	2	Nut-Nyloc 1/4-28
2	32144-57	2	Screw	15	116-2643	2	Decal-Wheel Nut Torque
3	82-6840	2	Spacer	17	116-6365	2	Cable-Park Brake, LH
4	60-1730	2	Pin-Clevis	18	116-1399	2	Locknut
5	3272-1	2	Pin-Cotter 1/16 X 1/2	19	3256-24	4	Washer-3/8 Sae
6	116-1746	2	Wheel Hub ASM	22	88-7970	2	Clip
6:2	116-1696	4	Stud-Wheel	23	3296-56	2	Nut-Nyloc 1/4-20 Thin
7	115-3590	2	Wheel And Tire ASM	24	116-6397	1	Bracket-Cable
7:1	109-3645	1	Rim ASM	25	32144-10	1	Screw-HWH 1/4-20 X .62
7:2	1-653160	1	Tire	26	32120-18	4	E-Ring
7:3	232-27	1	Stem-Valve	27	116-6182	2	Bracket-Brake, L
8	242-50	8	Nut-Lug 1/2-20	28	116-6347	2	Spring-Die
9	109-2889	2	Caliper-Brake	29	3256-22	4	Washer-1/4 Sae
10	109-0958	2	Plate-Mount, Brake	30	32151-86	2	E-Ring
11	92-5727	4	Screw-HH 3/8-16 X 1 1/4 Patch Lock	31	116-6348	2	Pin-Brake
				32	3334-945	2	Tie-Cable

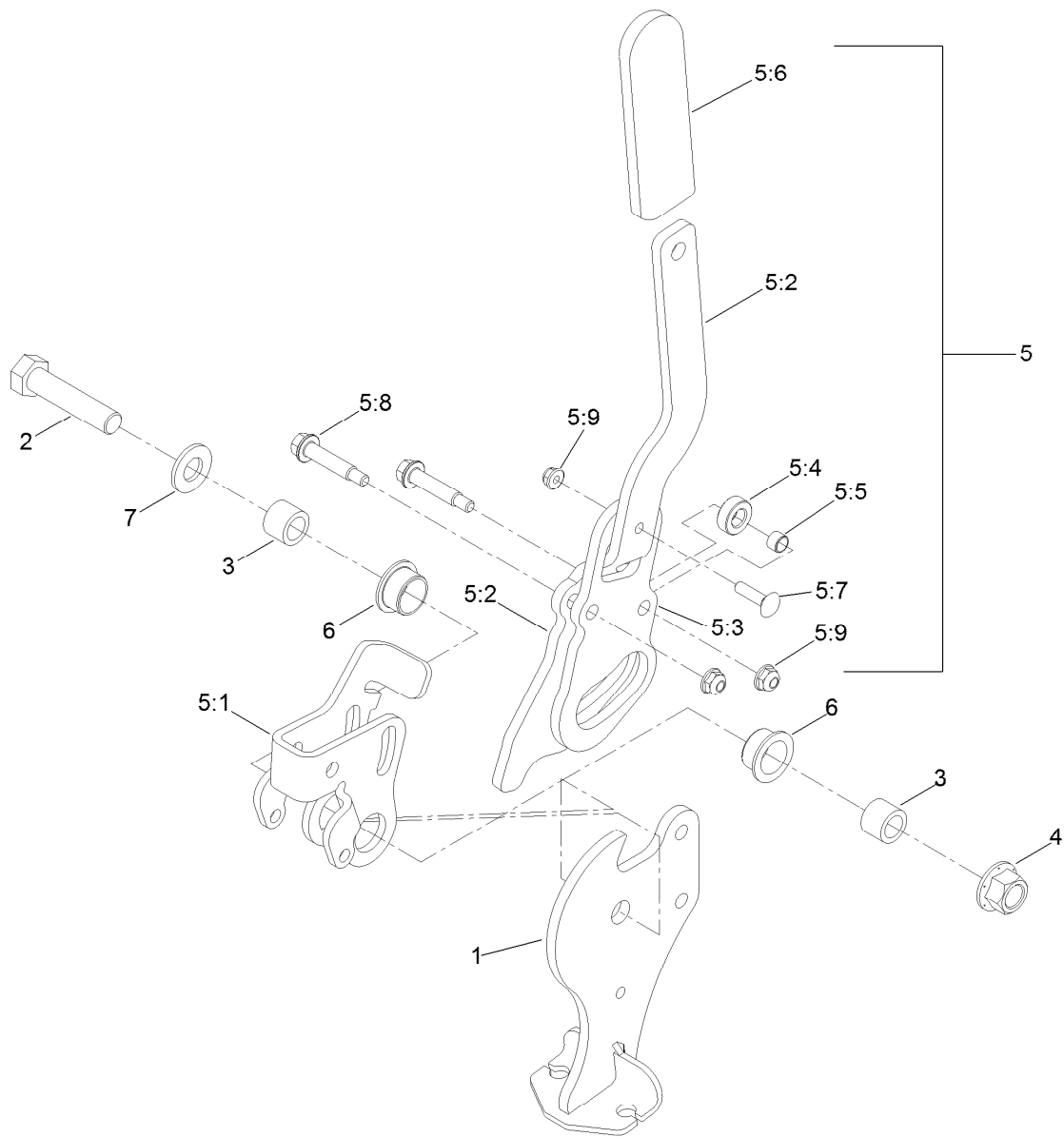

## Parking Brake Handle Assembly No. 116-7551

<i>Ref.</i>	<i>Part Number</i>	<i>Qty.</i>	<i>Description</i>	<i>Ref.</i>	<i>Part Number</i>	<i>Qty.</i>	<i>Description</i>
1	116-7263	1	Brake Pivot ASM	5:4	116-6846	1	Roller-Brake
2	325-9	1	Screw-HH	5:5	116-6852	1	Bearing-Sleeve
3	116-5384	2	Spacer	5:6	1-633268	1	Grip-Lever
4	99-5107	1	Nut-Lock	5:7	3229-2	1	Screw-CARR
5	116-6860	1	Handle ASM	5:8	116-6876	2	Screw-Shoulder
5:1	116-6856	1	Bellcrank-Brake	5:9	104-7201	3	Nut-HF
5:2	116-6857	1	Handle-Brake	6	109-8054	2	Bushing-Flange
5:3	116-6858	1	Plate-Handle	7	3256-26	1	Washer-Flat



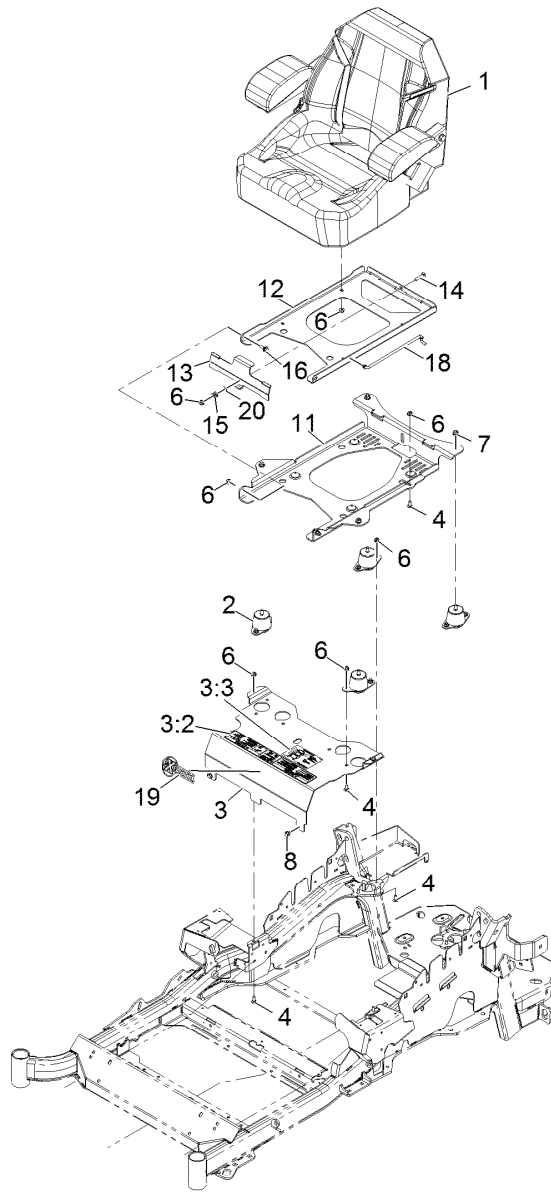

## Seat Assembly

<i>Ref.</i>	<i>Part Number</i>	<i>Qty.</i>	<i>Description</i>	<i>Ref.</i>	<i>Part Number</i>	<i>Qty.</i>	<i>Description</i>
1	116-4474	1	Seat,Exmark Standard Service	11	116-3860-03	1	Plate-Tilt, Seat Support
2	109-9034	4	Isolator-Seat	12	116-3859-03	1	Plate-Seat, Frame
3	116-2323	1	Mount-Seat	13	109-9881-03	1	Plate-Latch, Seat
3:2	109-7069	1	Decal-Console	14	3230-4	1	Bolt-Carriage 5/16-18 X 1 1/2
3:3	116-0211	1	Decal-Service Aid	15	107-3017	1	Spring-Compression
4	3230-23	11	Bolt-Carriage 5/16-18 X 3/4 Short Neck	16	116-1297	2	Screw-Shoulder
6	104-8300	18	Nut-Nyloc 5/16-18 Flg	18	116-0070	1	Rod-Prop
7	104-8301	4	Nut-Nyloc 3/8-16 Flg	19	103-2883	1	Decal
8	9266934	2	Screw-HWH 5/16 X 1/2 Tf	20	3256-23	1	Washer-5/16 Sae

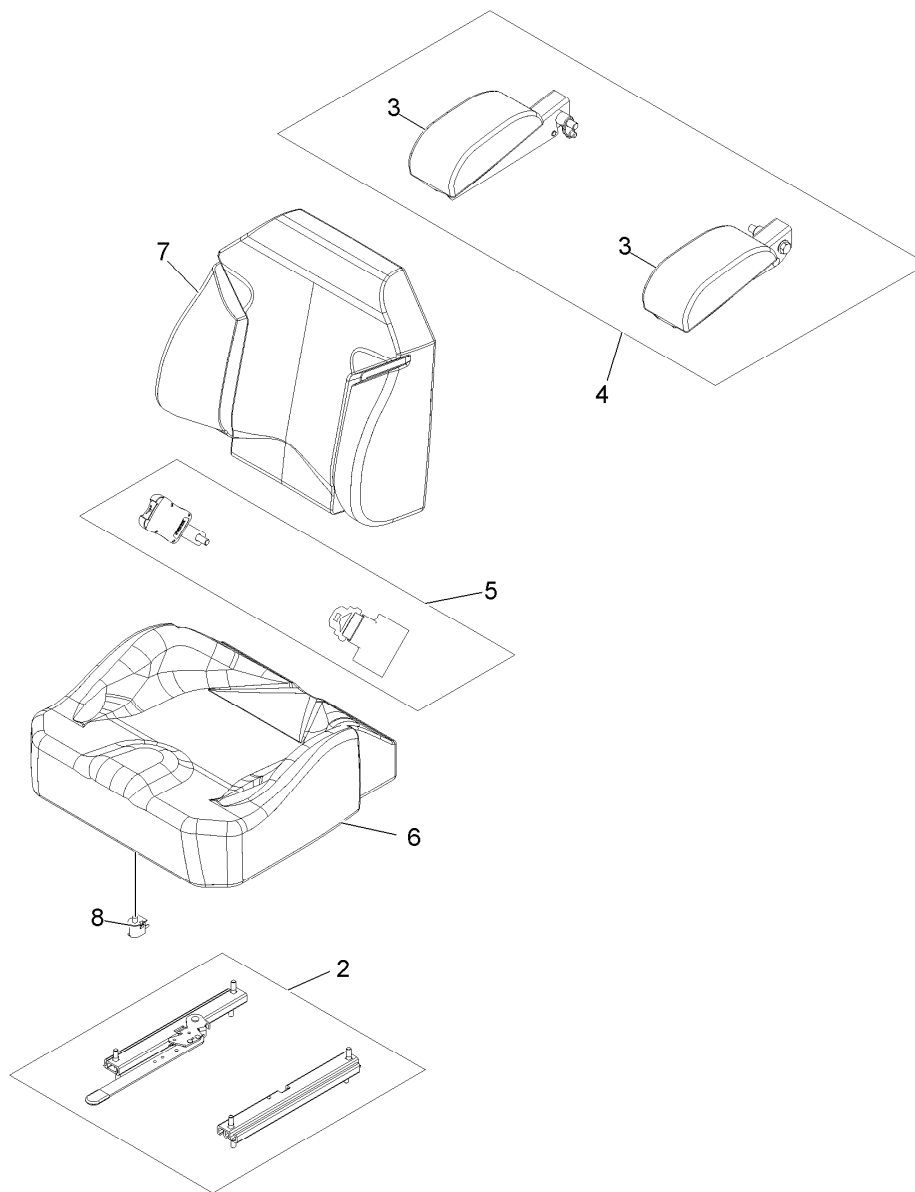

## Seat W/Tracks Assembly No. 116-4474

<i>Ref.</i>	<i>Part Number</i>	<i>Qty.</i>	<i>Description</i>
2	109-9801	1	Seat Track Set
3	109-9802	1	Arm Rest Pad Set
4	109-9803	1	Arm Rest Set
5	109-9805	1	Seat Belt Kit
6	116-4925	1	Cover,Cushion
7	116-4926	1	Cover,Back
8	82-2190	1	Switch

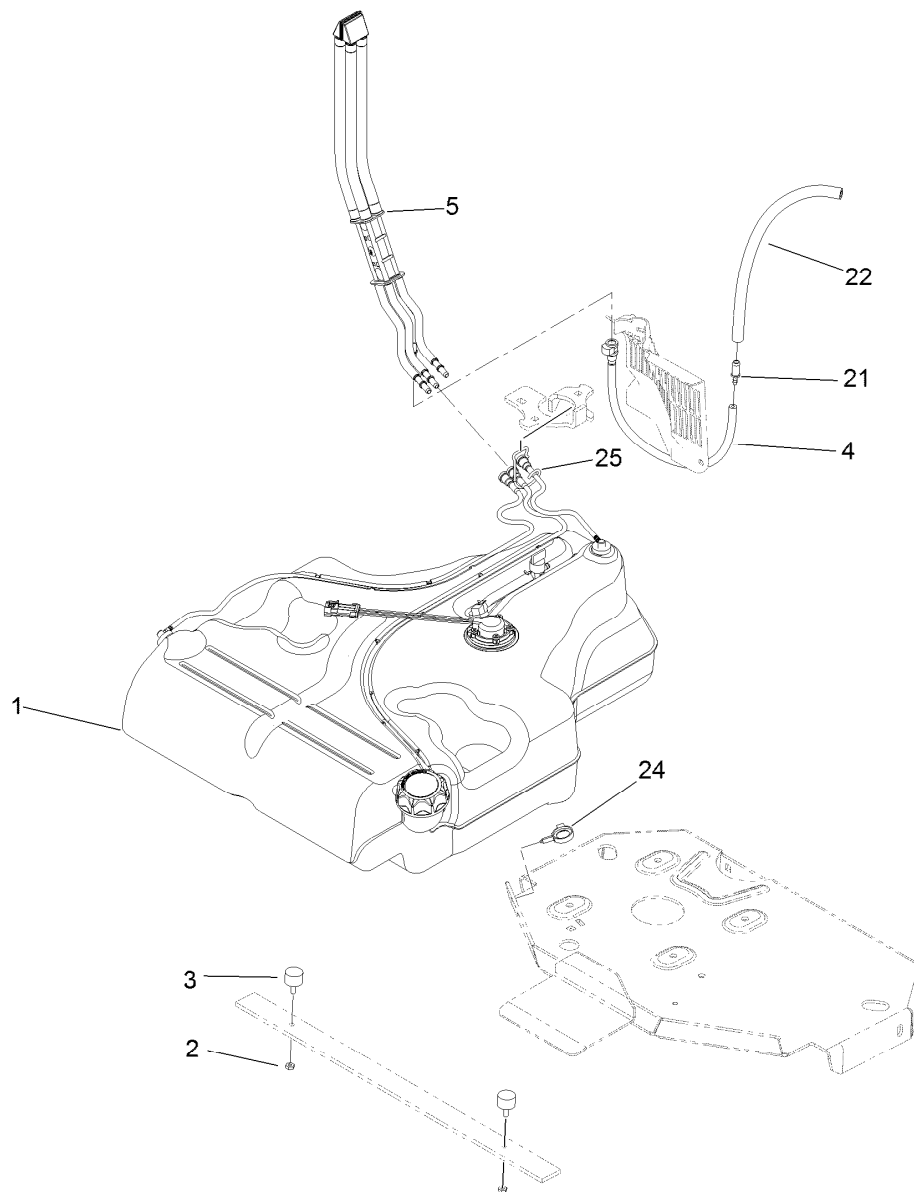

## Fuel Tank Mounting Assembly

Ref.	Part Number	Qty.	Description
1	116-3979	1	Fuel Tank ASM
2	3218-1	2	Nut-Jam
3	116-6380	2	Bumper-Rubber (W/ Stud)
4	116-3977	1	Hose ASM
5	109-9491	1	Fuel Manifold Vent ASM
21	98-2952	1	Fitting-Straight
22	116-5087	1	Hose-Fuel
24	105-1853	1	Clamp-Hose
25	116-6005	1	Retainer-Vapor Line

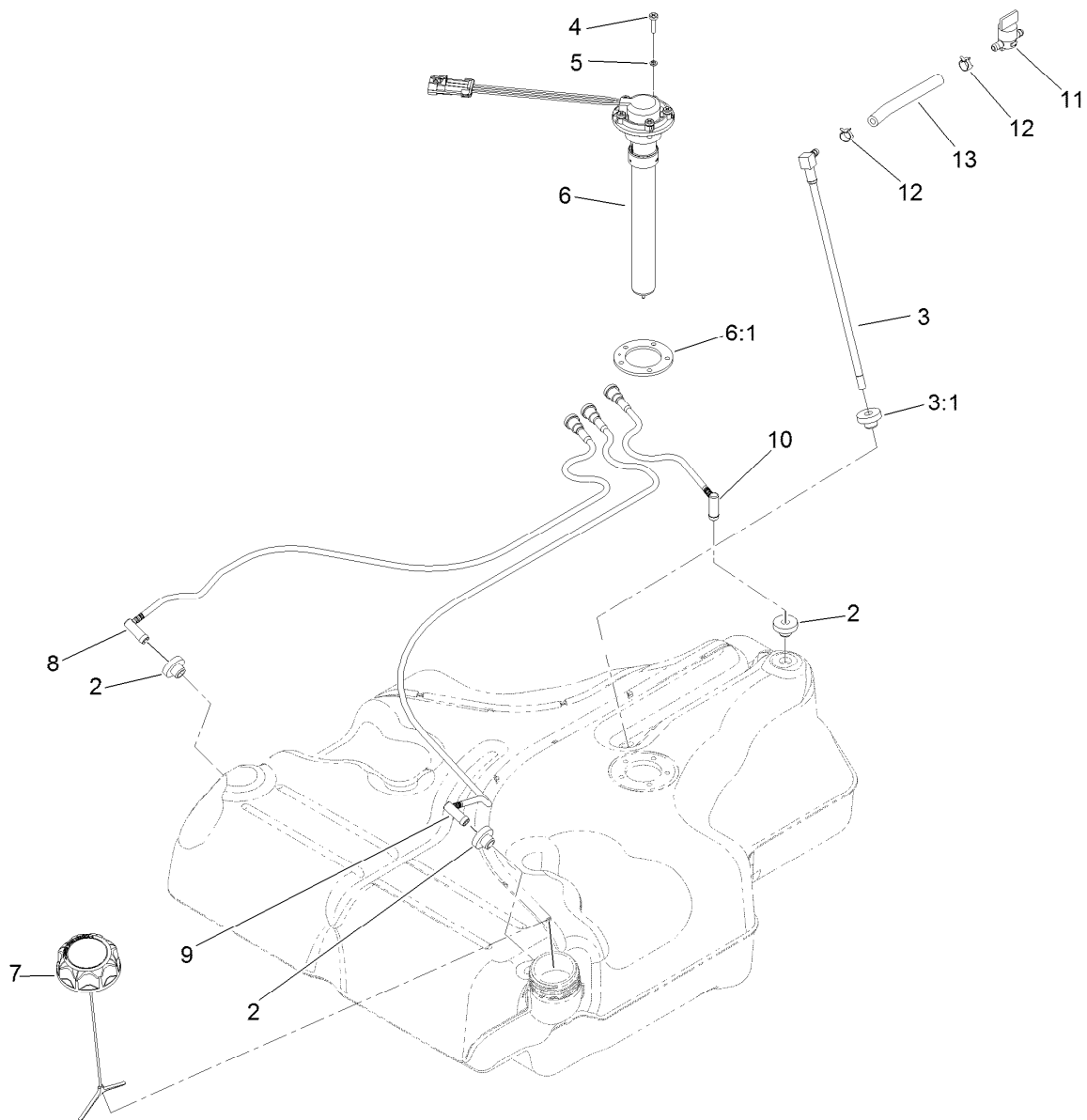

## Fuel Tank Assembly No. 116-3979

Ref.	Part Number	Qty.	Description
2	46-6560	4	Bushing
3	116-2459	1	Fuel Line Kit (With Grommet)
3:1	46-6560	1	Bushing
4	9107944	5	Screw-Pan
5	3253-17	5	Washer-Lock
6	116-0003	1	Sender-Fuel Level
6:1	109-9620	1	Gasket-Sender, Fuel
7	116-1704	1	Cap-Fuel, Ratcheting
8	116-2460	1	RH Vent Line Kit (With Grommet)
9	116-2461	1	LH Vent Line Kit (With Grommet)
10	116-2462	1	Rear Vent Line Kit (With Grommet)
11	1-603770	1	Valve-Fuel
12	2412-98	2	Clamp-Hose
13	109-0650	1	Hose-Fuel

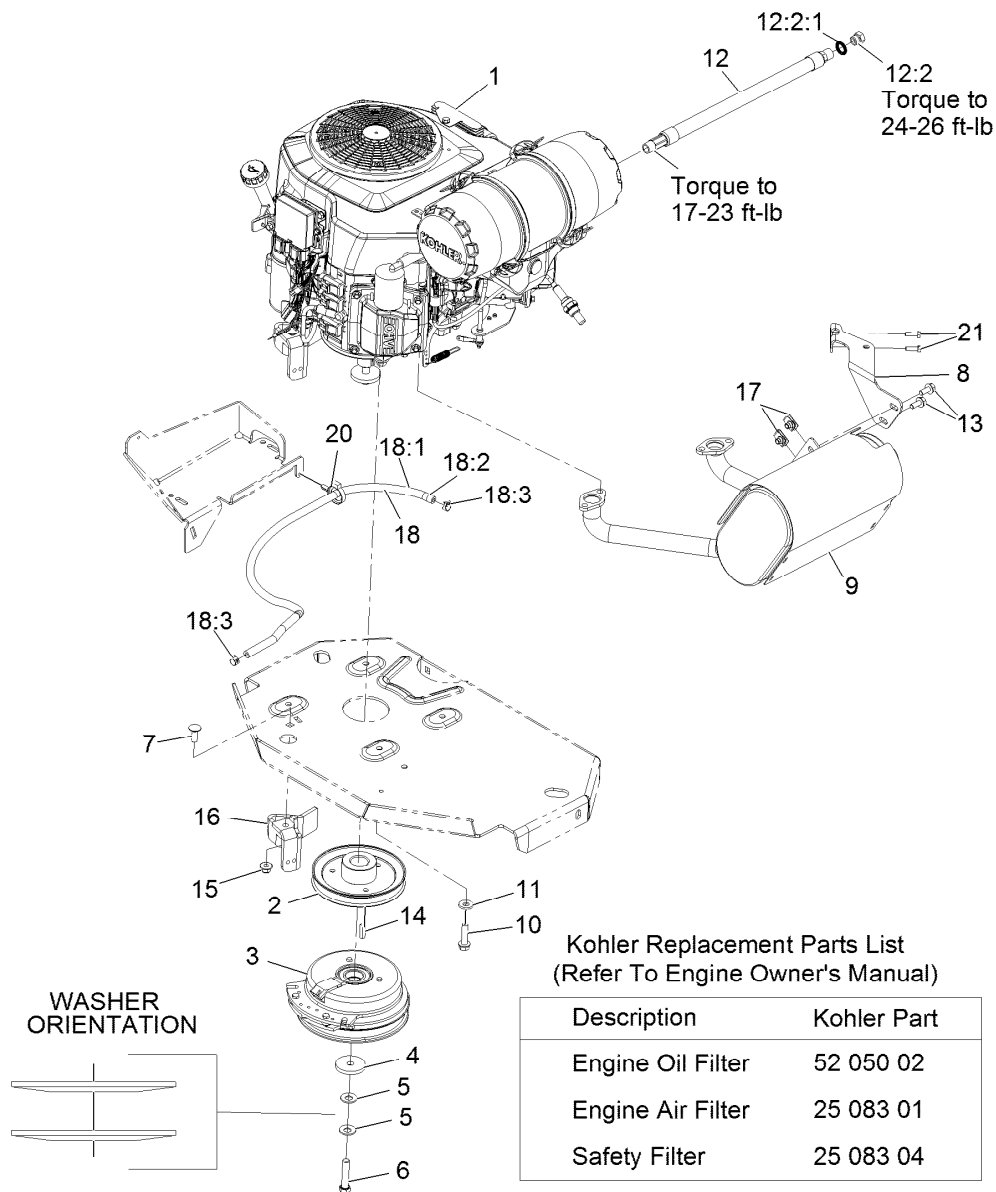

Kohler Replacement Parts List  
(Refer To Engine Owner's Manual)

Description	Kohler Part
Engine Oil Filter	52 050 02
Engine Air Filter	25 083 01
Safety Filter	25 083 04

## Engine Assembly

Ref.	Part Number	Qty.	Description
1		1	Engine-Kohler ●■
2	109-9905	1	Sheave
3	116-1620	1	Clutch Kit
4	109-6919	1	Washer-Clutch
5	1-603610	2	Washer-Spring Disc 7/16
6	109-9762	1	Screw-HH 7/16-20 X 2 W/Loctite ▲
7	3231-22	1	Bolt-Carriage 3/8-16 X 1
8	116-4297	1	Muffler Bracket Kit
9	116-2038	1	Muffler
10	32144-102	4	Screw-HWH 3/8-16 X 1 1/2 Taptite
11	98-5975	4	Washer-Spring Disc 3/8
12	116-5316	1	Oil Drain Hose ASM

Ref.	Part Number	Qty.	Description
12:2	353-508	1	Plug-W/O-Ring
12:2:1	237-42	1	O-Ring
13	3234-5	3	Screw-HH Flg 5/16-18 X 3/4
14	1-807259	1	Key-Machine 1/4 X 1/4 X 1
15	104-8301	1	Nut-Nyloc 3/8-16 Flg
16	116-2612-01	1	Clutch-Anchor
17	94-2413	3	U-Nut
18	117-3893	1	Fuel Line ASM
18:1	109-0273	1	Hose-Fuel Line 38 1/4"
18:2	117-3892	1	Sleeve-Thermal
18:3	2412-98	2	Clamp-Hose
20	104-2490	1	Clamp-Hose
21	116-4295	2	Screw-HH M6-1 X 20Mm W/Patch

● Not serviced separately

▲ Use Pro-Lock, Nut Type (P/N 1-840022, .5ml tube) on threads.

■ Obtain parts from [www.kohlerplus.com](http://www.kohlerplus.com)

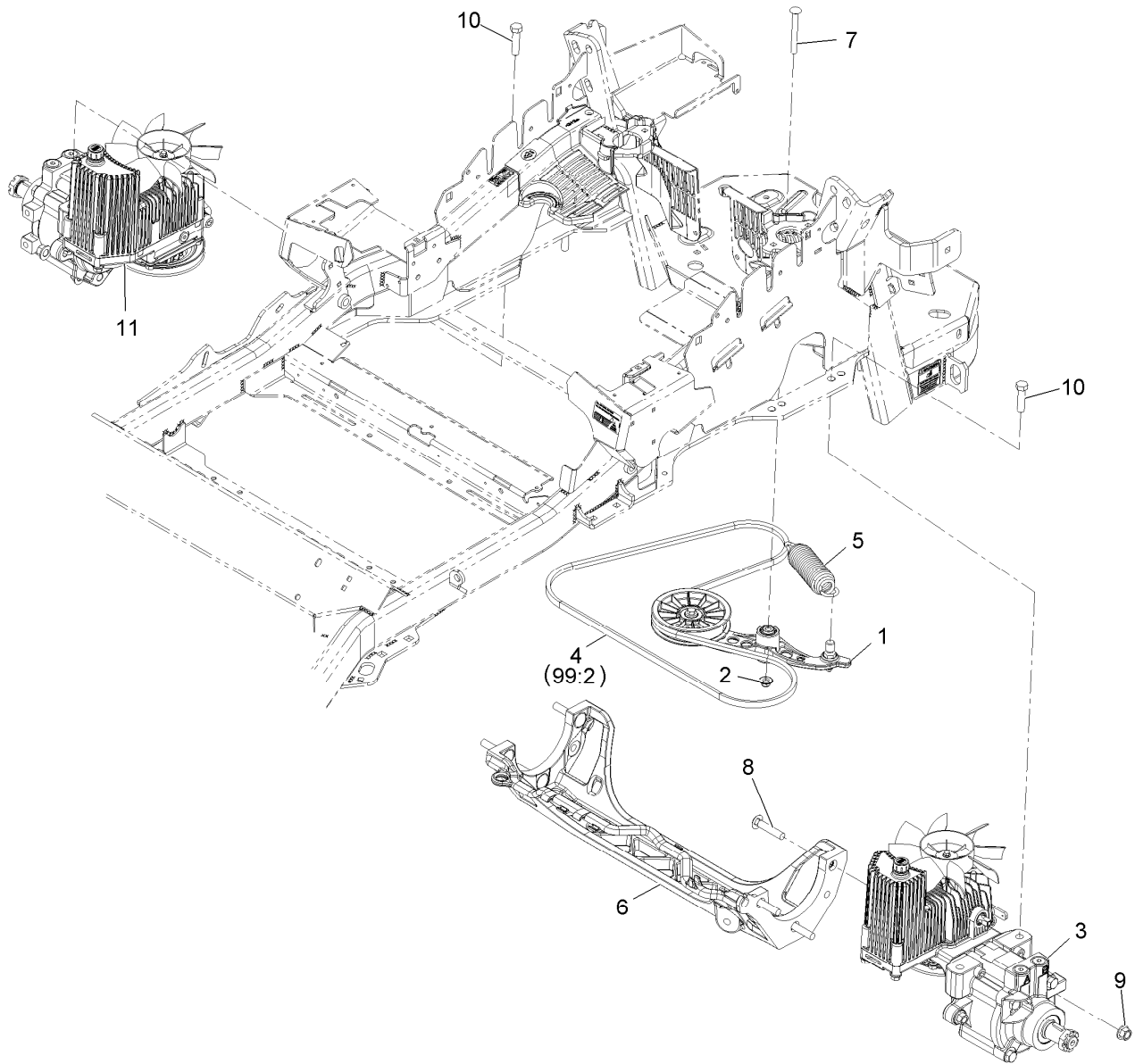

## Hydraulic Assembly

Ref.	Part Number	Qty.	Description	Ref.	Part Number	Qty.	Description
1	116-1255	1	Pump Idler ASM	10	325-8	4	Screw-HH 1/2-13 X 1 1/4
2	109-6658	1	Nut-Nyloc 3/8-16 Flg	11	116-6412	1	RH Hydro ASM (12Cc W/Check)
3	116-6411	1	LH Hydro ASM (12Cc W/Check)	99	109-9828	1	Bottle-Oil, 32Oz Hydraulic ●
4	109-3388	1	Belt	99	116-0164	1	Filter-Hydro ●
5	116-6317	1	Spring-Extension	99	116-1218	1	Bottle, Oil 1 Gallon Hydraulic ●
6	109-9375	1	Cradle-Hydro	99	116-3270	1	Kit, Hydro Service ●
7	116-1502	1	Bolt-Carriage Shoulder 3/8-16 X 3 1/2	99:1	109-9828	4	Bottle-Oil, 32Oz Hydraulic ●
8	3233-34	6	Bolt-Carriage 1/2-13 X 2 1/2	99:2	109-3388	1	Belt
9	99-5107	6	Nut-Lock 1/2-13	99:3	116-0164	2	Filter-Hydro ●

● Not illustrated

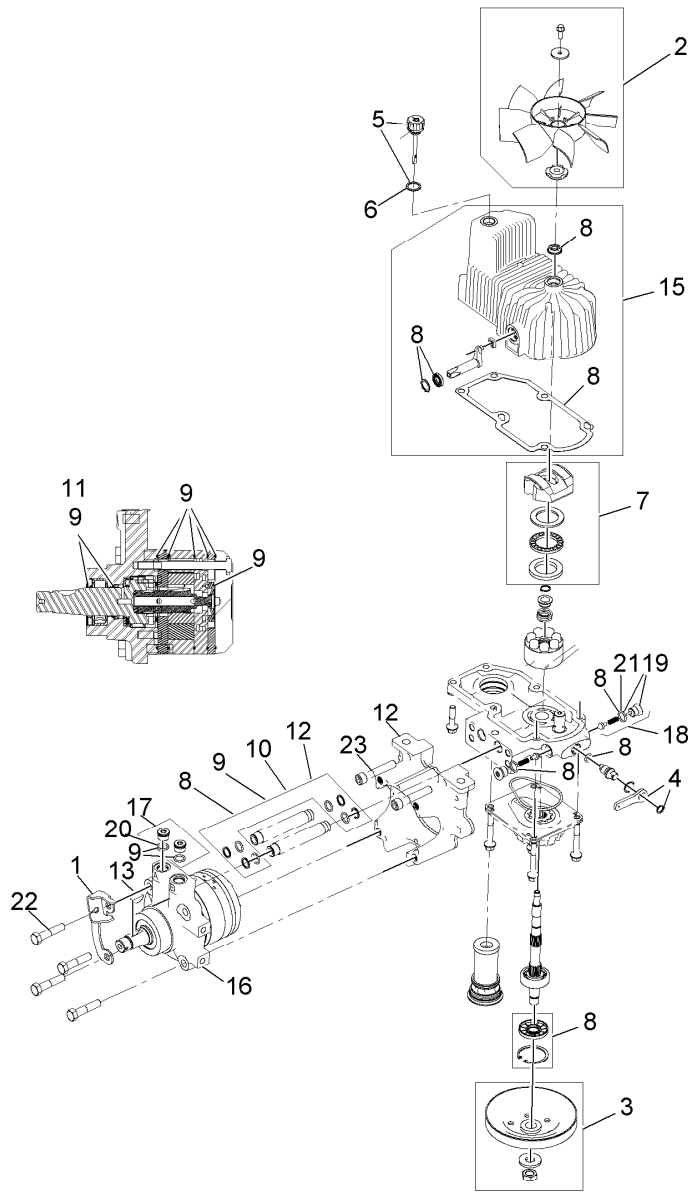

## LH Hydro Assembly No. 116-6411

Ref.	Part Number	Qty.	Description	Ref.	Part Number	Qty.	Description
1	116-6859	1	Bracket-Anchor, Cable	12	116-5469	1	Nose Cup-Uht
2	116-0233	1	Fan Kit	13	3257-42	1	Key-Woodruff 5/16 X 1
3	116-0234	1	Pulley Kit	15	116-3287	1	Housing-Hydro, LH
4	116-0235	1	Handle-Bypass Valve, Hydro	16	116-8915	1	Motor-Hydraulic LH 240Cc
5	116-0236	1	Dipstick-Hydro W/Gasket	17	116-7901	1	Magnetic Plugs Service Kit
6	116-0237	1	Gasket-Dipstick, Hydro	18	116-1630	2	Check Valve ASM
7	116-1367	1	Swash Block Kit	19	116-1631	2	Plug-Check (W/O-Ring)
8	116-1368	1	Pump Seal Kit	20	76-1900	2	O-Ring
9	116-1369	1	Motor Seal Kit	21	116-8662	2	O-Ring-Check Valve
10	116-1370	1	Tube Seal Kit	22	116-8974	4	Screw-HH 1/2-20 X 2 1/4
11	116-1371	1	Output Shaft Seal Kit	23	116-8975	2	Screw-HSH 1/2-20 X 2 3/4
				99	116-1373	1	Flow Test Kit ●

● Not illustrated

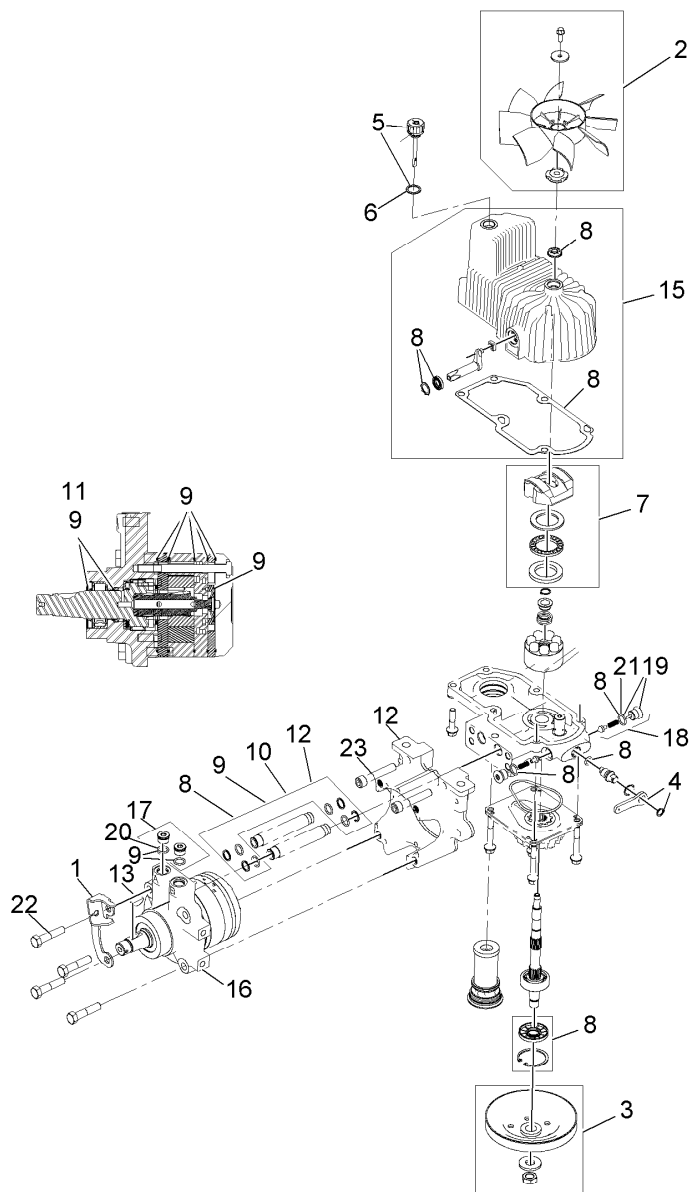

## RH Hydro Assembly No. 116-6412

Ref.	Part Number	Qty.	Description	Ref.	Part Number	Qty.	Description
1	116-6859	1	Bracket-Anchor, Cable	12	116-5469	1	Nose Cup-Uht
2	116-0233	1	Fan Kit	13	3257-42	1	Key-Woodruff 5/16 X 1
3	116-0234	1	Pulley Kit	15	116-3288	1	Housing-Hydro, RH
4	116-0235	1	Handle-Bypass Valve, Hydro	16	116-8916	1	Motor-Hydraulic RH 240Cc
5	116-0236	1	Dipstick-Hydro W/Gasket	17	116-7901	1	Magnetic Plugs Service Kit
6	116-0237	1	Gasket-Dipstick, Hydro	18	116-1630	2	Check Valve ASM
7	116-1367	1	Swash Block Kit	19	116-1631	2	Plug-Check (W/O-Ring)
8	116-1368	1	Pump Seal Kit	20	76-1900	2	O-Ring
9	116-1369	1	Motor Seal Kit	21	116-8662	2	O-Ring-Check Valve
10	116-1370	1	Tube Seal Kit	22	116-8974	4	Screw-HH 1/2-20 X 2 1/4
11	116-1371	1	Output Shaft Seal Kit	23	116-8975	2	Screw-HSH 1/2-20 X 2 3/4
				99	116-1373	1	Flow Test Kit ●

● Not illustrated





## Pump Idler Assembly No. 116-1255

Ref.	Part Number	Qty.	Description
2	43-0940	1	Spacer
3	103-3504	2	Bearing-Spherical
4	103-3505	1	Seal-Double Lip
5	103-3506	1	Seal-Single Lip
6	109-6658	1	Nut-Flange, NI
7	106-7159	2	O-Ring
8	323-8	1	Screw-HH
9	32120-10	2	Ring-Snap
10	302-19	1	Fitting-Grease
11	109-8076	1	Pulley-Idler
12	116-3467	1	Pin-Spring, Anchor

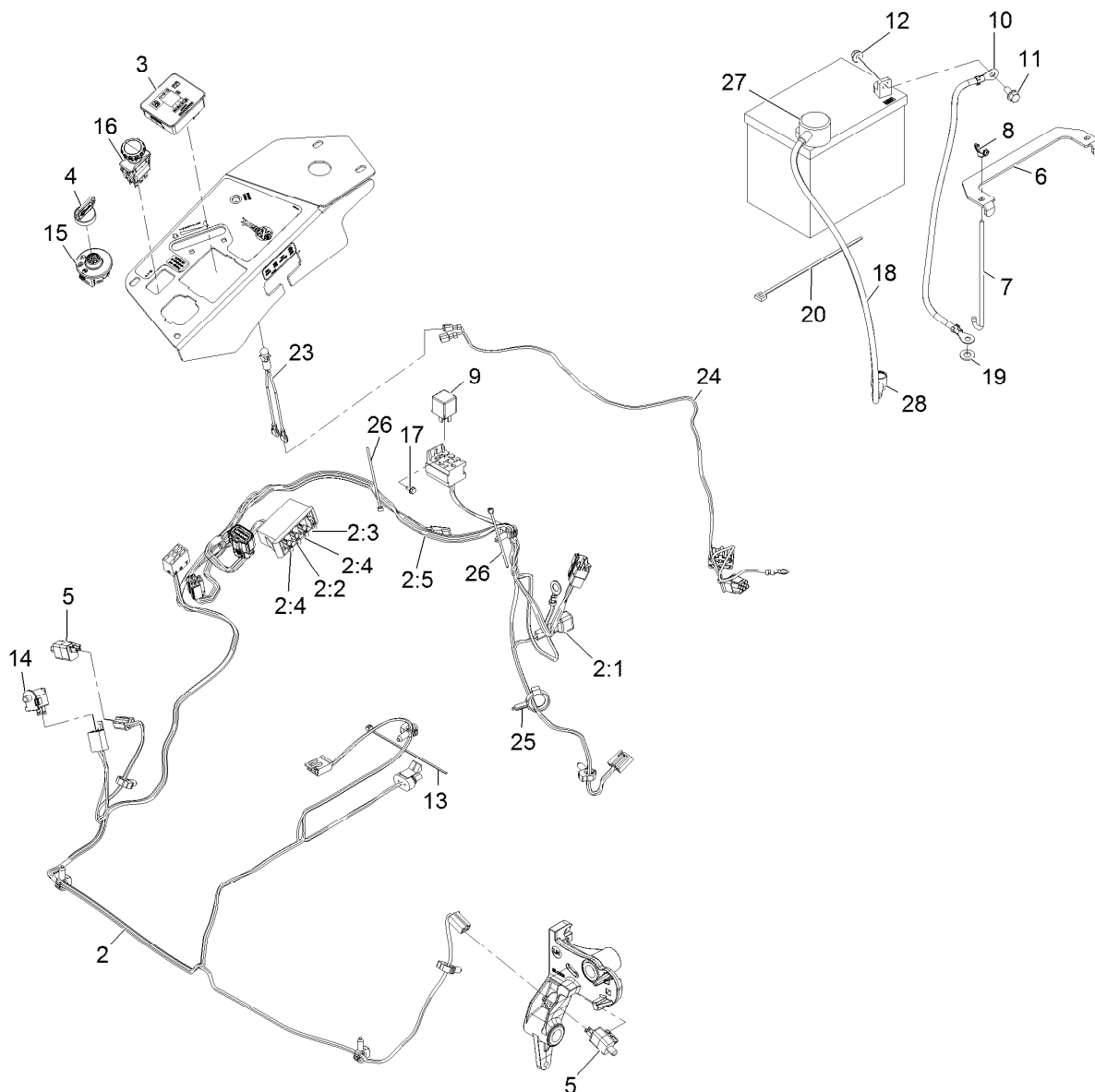

## Electrical Assembly

Ref.	Part Number	Qty.	Description	Ref.	Part Number	Qty.	Description
2	116-6009	1	Harness-Wire, Main ●	12	104-8300	2	Nut-Nyloc 5/16-18 Flg
2:1	103-3895	1	Diode-Tvs	13	1-303287	3	Tie-Cable 5 1/2 (Small)
2:2	218-578	1	Fuse-Blade, 10 Amp	14	82-2190	1	Switch
2:3	109355	1	Fuse-Blade, 15 Amp	15	117-2221	1	Switch-Ignition
2:4	109102	2	Fuse-Blade, 25 Amp	16	116-0124	1	Switch-PTO, 10A
2:5	116-0053	1	Cap-Plug	17	104-2065	1	Screw-HWH #10-24 X 3/8
3	117-3882	1	Fuel/Hour Meter ASM	18	115-3864	1	Cable-Battery, Positive
4	1-603511	1	Key-Ignition	19	3256-24	1	Washer-3/8 Sae
4	103-2106	1	Key-Exmark Logo	20	1-303335	1	Tie-Cable 7 15/16 (Large)
5	110-6765	2	Switch-Single Pole No	23	1-643267	1	Indicator-Red Led
6	116-0042-03	1	Strap-Tie Down, Battery	24	116-3062	1	Harness-Indicator Light
7	1-633651	2	Bolt-Holddown	25	105-1853	1	Clamp-Hose
8	1-543792	2	Wingnut-Nyloc 1/4-20	26	1-303287	2	Tie-Cable 5 1/2 (Small)
9	1-643275	1	Relay-12Vdc 40 Amp	27	109-2407	1	Insulator-Battery
10	114-1218	1	Cable-Battery, Negative	28	1-543393	1	Insulator-Solenoid
11	3234-5	2	Screw-HH Flg 5/16-18 X 3/4				

● Use dielectric grease on all unsealed connectors and terminals only. Do not apply in sealed connectors.

# EXMARK® MAINTENANCE

## MAXIMIZE THE PERFORMANCE OF YOUR EXMARK.

### **4-CYCLE PREMIUM ENGINE OIL**

Part No. 116-3373

Both SAE 30 and SAE 10W-30 in one bottle.

Contains increased levels of zinc and phosphorus for better lubricity.

No Viscosity Index Improvers that tend to shear down in high heat.

Synthetic formulation.

Gas & Diesel compatible.

Anti-corrosion additives.

API 'SL' and JASO rated with wet clutch compatibility for other machines.

### **PREMIUM HYDRO OIL**

Part No. 109-9828

Commercial quality for tough, high-heat conditions.

Designed specifically for zero-turn mower hydraulic systems.

Superior shear resistance under heavy loads.

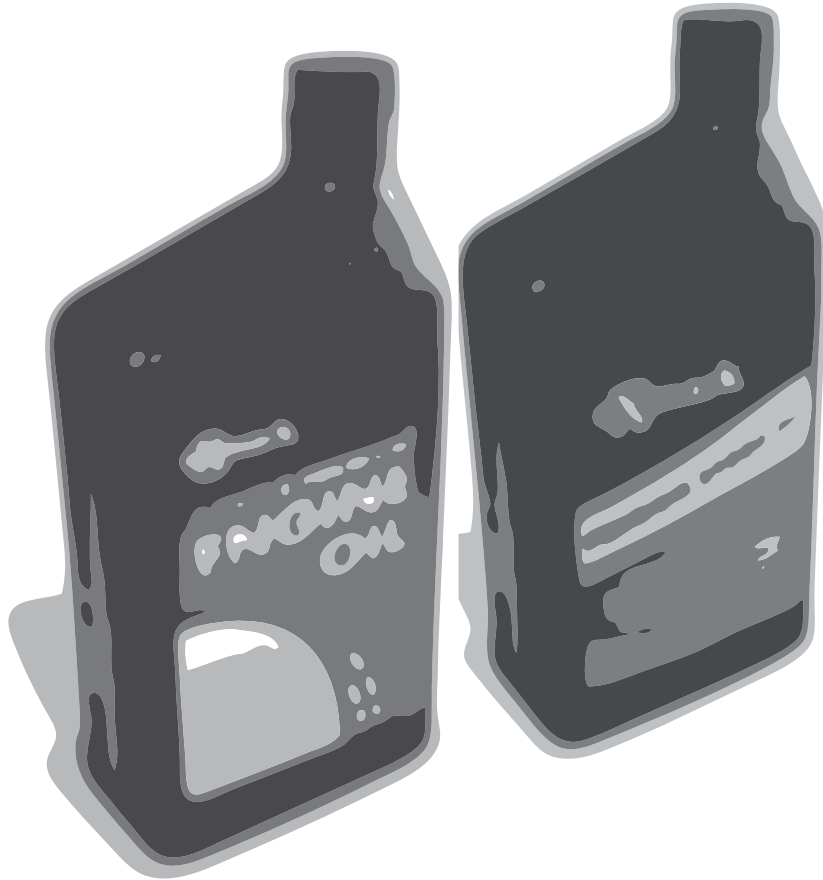

Available from your local Exmark dealer. Find your closest dealer at [exmark.com](http://exmark.com)

## EXMARK ACCESSORIES AND OPTIONS\*

### MID-MOUNT RIDING ACCESSORIES AND OPTIONS

CUSTOM RIDE SEAT SUSPENSION SYSTEM	OPERATOR CONTROLLED DISCHARGE
FULL SUSPENSION SEAT	SUN SHADE
DECK LIFT ASSIST KIT	TRASH CONTAINER
HITCH KIT	TURF STRIPER
LIGHT KIT	ULTRA VAC COLLECTION SYSTEM
12V POWER PORT	ULTRA VAC QUICK DISPOSAL SYSTEM
MICRO-MULCH SYSTEM	

### OUT-FRONT RIDING ACCESSORIES AND OPTIONS

CUSTOM RIDE SEAT SUSPENSION SYSTEM	SNOW BLADE
DUAL-TAIL WHEEL	SNOWBLOWER
FLOOR PAN EXTENDER	SUN SHADE
HITCH KIT	TRASH CONTAINER
LIGHT KIT	ULTRA VAC COLLECTION SYSTEM
MICRO-MULCH SYSTEM	ULTRA VAC QUICK DISPOSAL SYSTEM
ROLL OVER PROTECTION SYSTEM (ROPS)	WEATHER CAB

### WALK-BEHIND ACCESSORIES AND OPTIONS

GRASS CATCHER	TURF STRIPER
MICRO-MULCH SYSTEM	STANDON

\*Some accessories and options not available for some models.

Place Model No. and Serial No.  
Label Here (Included in the Literature  
Pack) or Fill in Below

Model No. \_\_\_\_\_

Serial No. \_\_\_\_\_

Date Purchased \_\_\_\_\_

Engine Model No. and Spec. No. \_\_\_\_\_

Engine Serial No. (E/No) \_\_\_\_\_

© 2012 Exmark Mfg. Co., Inc.  
Industrial Park Box 808  
Beatrice, NE 68310  
All Rights Reserved

Part No. 4501-401 Rev. A  
(402) 223-6300  
Fax (402) 223-5489  
Printed in the USA.

