

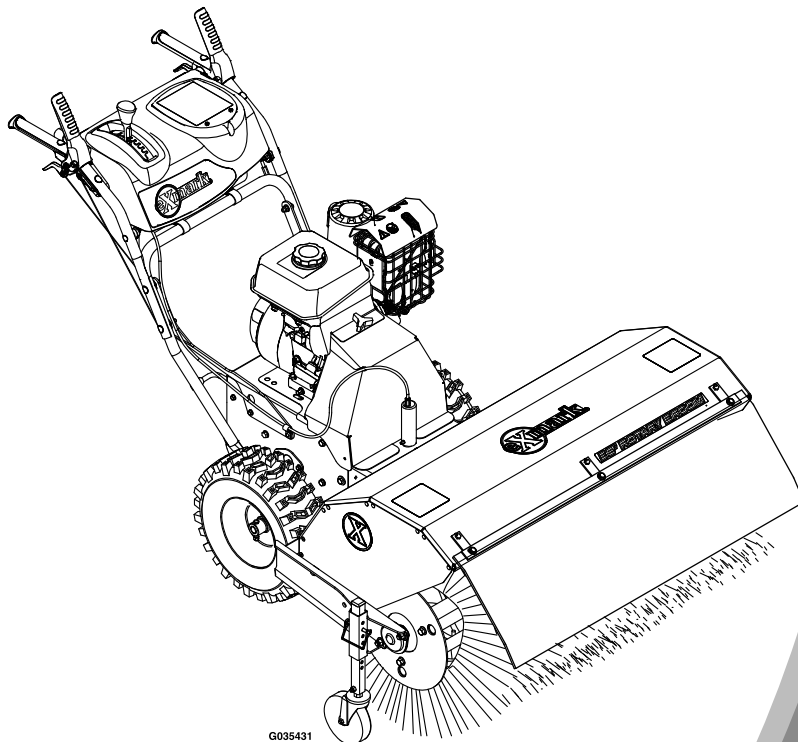

WALK-BEHIND ROTARY BROOM

Model No. BRS270CKC36000—Serial No. 404314159 and Up

Picture below may not reflect actual product.



G035431

Parts Manual

Part No. 4504-204 Rev. A

Ordering Replacement Parts

To order replacement parts, please supply the part number, the quantity, and the description of each part desired.

Understanding Reference Numbers

Each identified part in an illustration has a reference number. The reference number for a part also appears in the parts list, along with other information about the part.

This catalog uses two special reference number formats, one to indicate parts in a service assembly and another to indicate the quantity of a given part in an illustration.

Service Assembly Reference Numbers

Parts in service assemblies have reference numbers in the form a:b. The a represents the reference number of the entire service assembly and the b represents a sequential number unique to each part within the service assembly.

For example, a wheel assembly might be identified by reference number 6, the tire by 6:1, the valve by 6:2, and the wheel by 6:3. When you order the assembly identified by reference number 6, you receive all parts identified by reference numbers 6:1, 6:2, and 6:3. However, you may also order any part individually. Reference numbers of this type appear in illustration and in parts lists.

Reference Numbers Indicating Quantity

In an illustration, if a reference number indicates more than one part, the reference number has the form nX y. The n represents the quantity of the part, the X is the multiplication symbol, and the y represents the reference number.

For example, in an illustration, the reference number 2X 37 means that two of the parts identified by reference number 37 are indicated.

Touch Up Paint

Exmark black touch up spray paint – gloss black.

Exmark red touch up paint (spray paint – P/N 1-850337 - .6 oz liquid bottle – P/N 103-9140).



If your Exmark dealer does not have the Exmark part in stock, Exmark will get the parts to the dealer the next business day or the part will be FREE Guaranteed!! (Some restrictions apply. See your participating Exmark Dealer for details.)

Contents

Main Frame Assembly	4
Clutch Drive Assembly	6
Wheel Clutch Sprocket Assembly	8
Control Panel Assembly	10
Handle Assembly	12
Engine Assembly	14
Broom Head and Shield Assembly	16
Mounting Assembly	18
Hood and Frame Assembly	20
Core Assembly	22

Main Frame Assembly

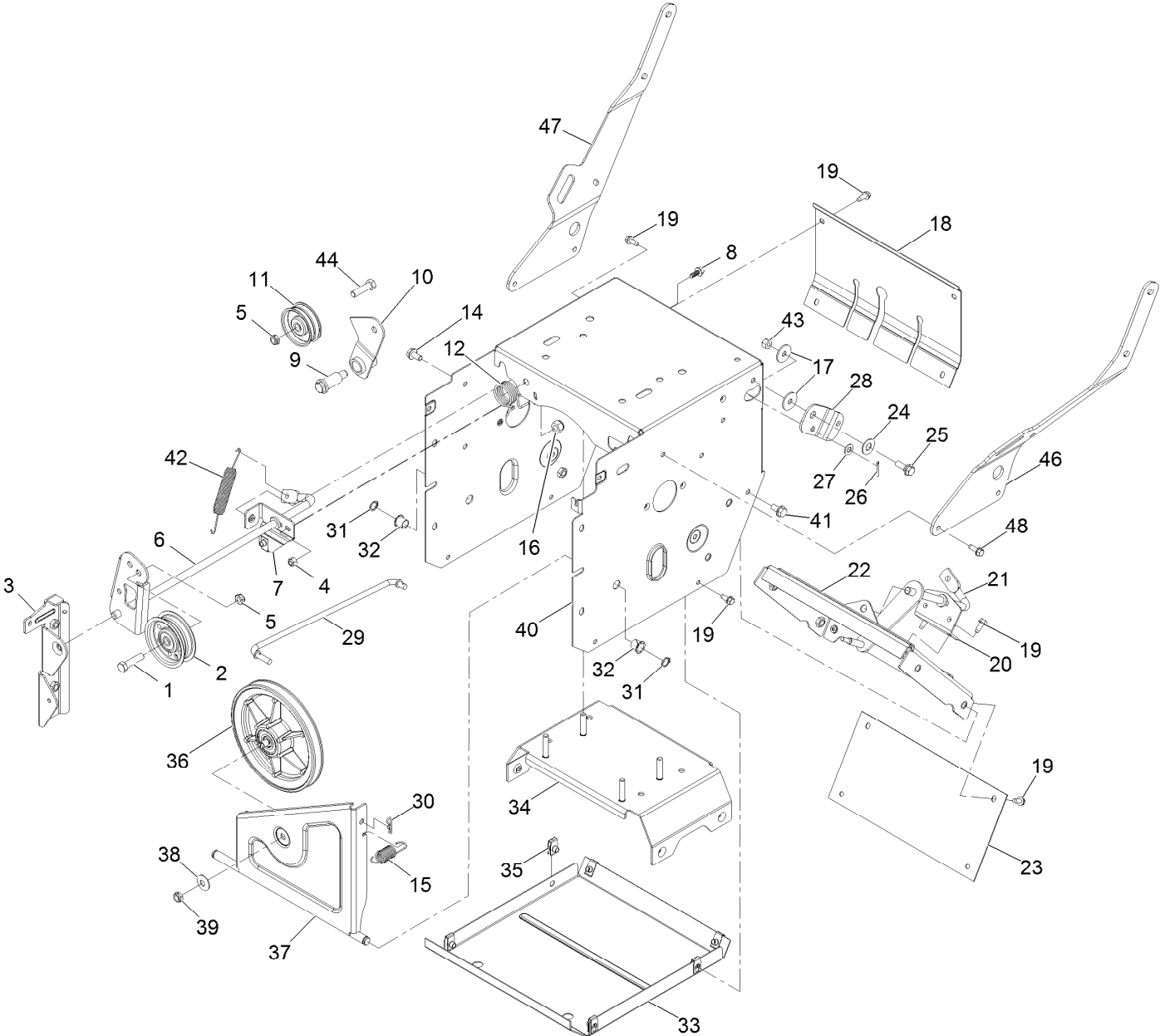

Main Frame Assembly (continued)

<i>Ref.</i>	<i>Part Number</i>	<i>Qty.</i>	<i>Description</i>	<i>Ref.</i>	<i>Part Number</i>	<i>Qty.</i>	<i>Description</i>
1	323-8	1	Screw-HH 3/8-16 X 1 1/2	26	3272-4	1	Pin-Cotter
2	92-7104	1	Pulley-Idler	27	3256-23	1	Washer-5/16 SAE
3	136-7112	1	Bracket-Impeller, Idler	28	136-7110	1	Bellcrank
4	3296-42	1	Nut-Nyloc 1/4-20	29	136-7101	1	Link-Speed, Control
5	3296-59	2	Nut-Nyloc 3/8-16 Thin	30	3290-307	1	Pin-Cotter
6	107-3838-03	1	Impeller Clutch ASM	31	32151-61	2	Ring-Retaining
7	136-7181	1	Bracket-Impeller, Clutch	32	256-257	2	Bushing-Nyliner
8	99-6810	1	Screw-HH 1/4-20 X 5/8	33	106-7330-03	1	Pan-Bottom
9	136-7116	1	Bolt-Shoulder ●	34	116-7678	1	Brace-Frame
10	108-5058	1	Arm-Idler, Traction	35	107069	8	Nut-Retainer-Panel 1/4-20
11	3-4244	1	Pulley-Idler	36	136-7319	1	Pulley-Traction ASM
12	108-7332	1	Spring-Torsion	37	136-7118	1	Bracket-Wheel, Friction
14	3234-7	2	Screw-HH Flg 5/16-18 X 5/8	38	3290-340	1	Washer-Belleville
15	107-1003	1	Spring-Extension	39	3296-5	1	Nut-Nyloc 3/8-24 Thin
16	3296-76	1	Nut-Lock, NI	40	120-9832-03	1	Traction Frame ASM
17	5-4460	2	Washer-Pivot	41	32144-14	4	Screw-HWHTF
18	108-0022-03	1	Cover-Upper	42	136-7115	1	Spring-Extension
19	32144-10	13	Screw-HWH 1/4-20 X .62	43	3296-29	1	Nut-Nyloc 5/16-18
20	136-7114	1	Bracket-Shift, Rod	44	323-29	1	Screw-HH 3/8-16 X 1 3/8
21	136-7106	1	Traction Lever ASM	46	116-7672-03	1	Brace-Handle, LH
22	108-0026-03	1	Shift Plate ASM	47	116-7673-03	1	Brace-Handle, RH
23	106-7345-03	1	Cover-Lower	48	32144-44	4	Screw-HWH 1/4-20 X 3/4
24	25-5640	1	Washer				
25	27-0410	1	Screw-Shoulder 5/16-18 X 1 Sp				

● Apply light coat of anti-seize to pivot surface.

Clutch Drive Assembly

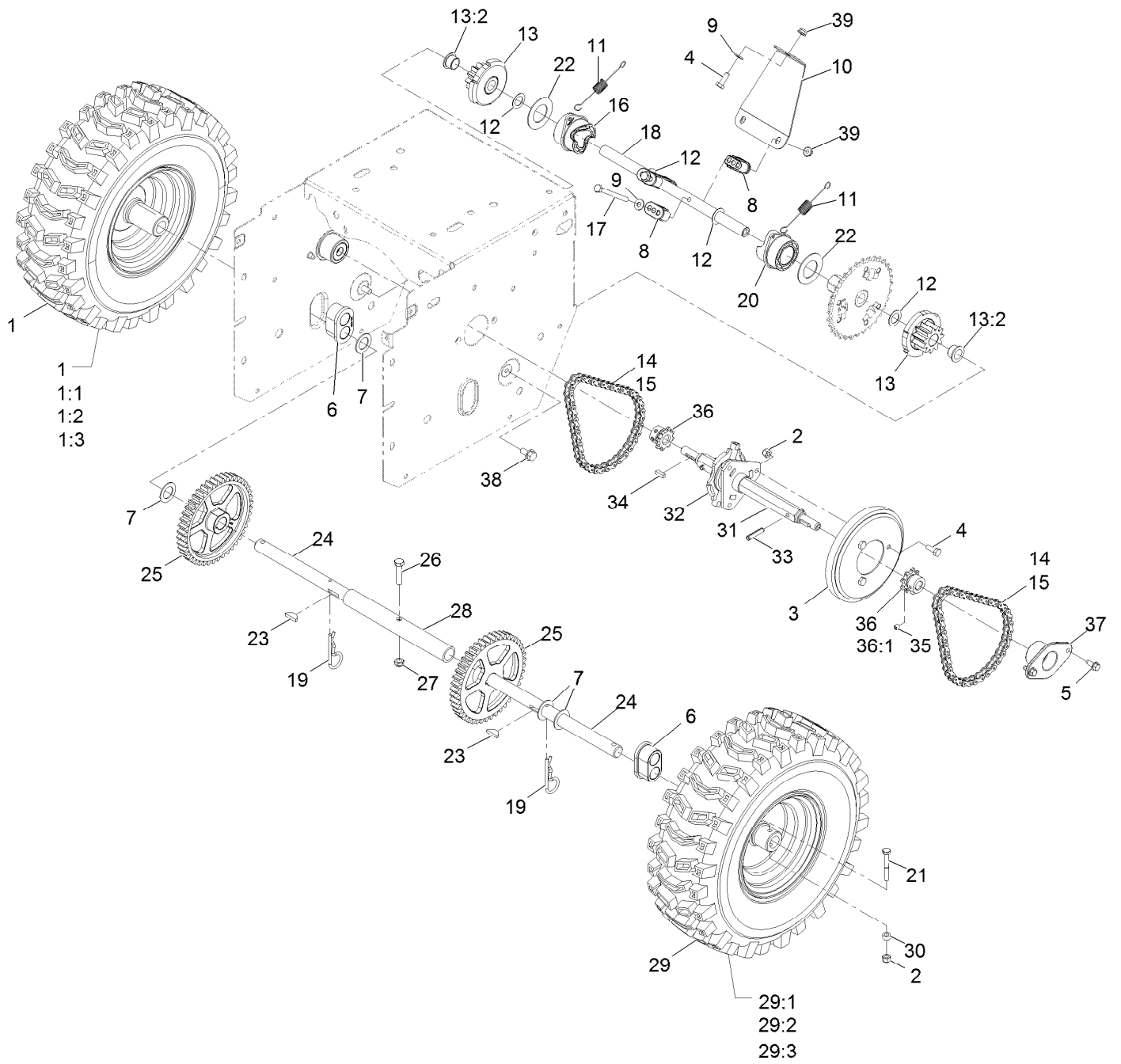

Clutch Drive Assembly (continued)

<i>Ref.</i>	<i>Part Number</i>	<i>Qty.</i>	<i>Description</i>	<i>Ref.</i>	<i>Part Number</i>	<i>Qty.</i>	<i>Description</i>
1		1	RH Wheel And Tire ASM ●	21	108-2975	2	Screw-HH
1:1	107-3042	1	Tire	22	107-8891	2	Washer-Thrust
1:2	107-3043	1	Rim-Tire	23	3257-7	2	Key-Woodruff
1:3	232-27	1	Stem-Valve	24	107-8898	2	Shaft-Axle
2	3296-42	5	Nut-Nyloc 1/4-20	25	106-4572	2	Gear-Axle, 44 Tooth
3	119-1567	1	Wheel-Friction	26	322-17	1	Screw-HH 5/16-18 X 1 3/8
4	321-4	4	Screw-HH 1/4-20 X 3/4	27	3296-47	1	Nut-Nyloc 5/16-18 Thin
5	32144-10	4	Screw-HWH 1/4-20 X .62	28	106-7259	1	Tube-Axle
6	106-4558	2	Bearing-Axle	29		1	LH Wheel And Tire ASM ●
7	3-8664	4	Washer-Thrust	29:1	107-3042	1	Tire
8	107-8889	4	Guide-Collar	29:2	107-3043	1	Rim-Tire
9	3256-22	3	Washer-1/4 SAE	29:3	232-27	1	Stem-Valve
10	107-8892-03	1	Brace-Collar, Shift	30	55-9370	2	Spacer-Blade, Rotor
11	107-8893	2	Spring-Extension	31	116-7908	1	Shaft-Hex ▲
12	108-0015	4	Washer-Flat	32	106-4434	1	Trunnion-Hex
13	107-8894	2	11T Gear ASM	33	32121-9	2	Pin-Roll, Slotted
13:2	108-2973	2	Bushing-Flange	34	94-8850	2	Key-Square
14	108-0016	2	Chain-Roller	35	3245-32	4	Screw-HSH
15	2710-6	2	Link-Connecting	36	106-7317	2	Sprocket-8 Tooth
16	107-8888	1	Collar-Shift, RH	36:1	3245-32	2	Screw-HSH
17	321-23	2	Screw-HH	37	108-7319	2	Retainer-Bearing
18	107-8883	1	Shaft-Intermediate ■	38	32144-14	2	Screw-HWHTF
19	3290-343	2	Pin-Hair	39	104-7201	3	Nut-Nyloc 1/4-20 Flg
20	107-8887	1	Collar-Shift, LH				

● Not serviced separately

▲ Apply light coat of oil to hex portion of shaft.

■ Apply light coat of oil before assembly.

Wheel Clutch Sprocket Assembly

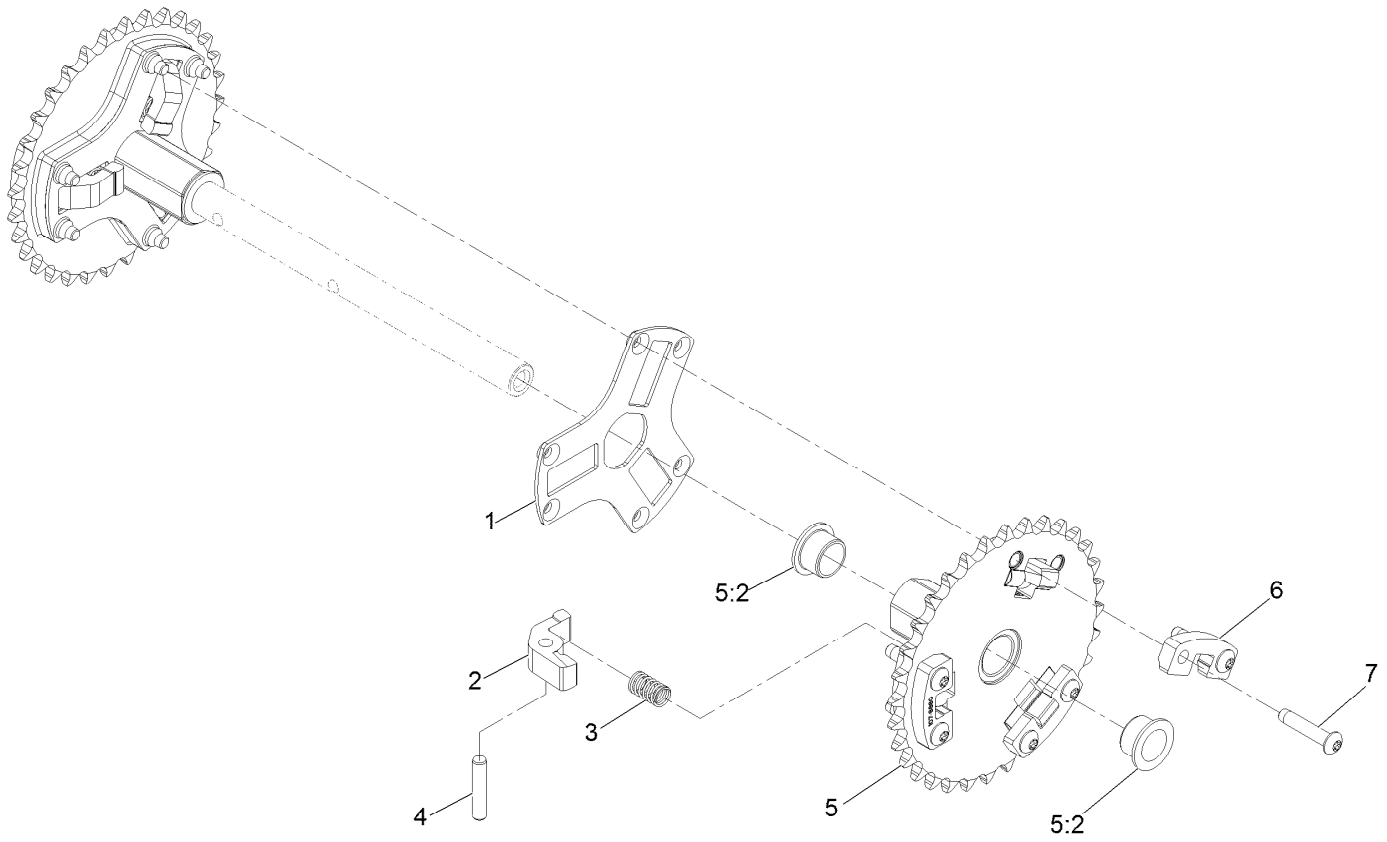

Wheel Clutch Sprocket Assembly (continued)

<i>Ref.</i>	<i>Part Number</i>	<i>Qty.</i>	<i>Description</i>	<i>Ref.</i>	<i>Part Number</i>	<i>Qty.</i>	<i>Description</i>
1	136-7318	2	Retainer-Pawl, Pin	5	107-8895	2	32T Sprocket ASM
2	107-8879	6	Pawl-Clutch	5:2	108-2973	2	Bushing-Flange
3	107-8885	6	Spring-Compression	6	107-8880	6	Support-Pawl
4	107-8899	6	Pin-Dowel ●	7	108-0035	12	Screw-TTH, Thread Rolling

● Apply light coat of oil before assembly.

Control Panel Assembly

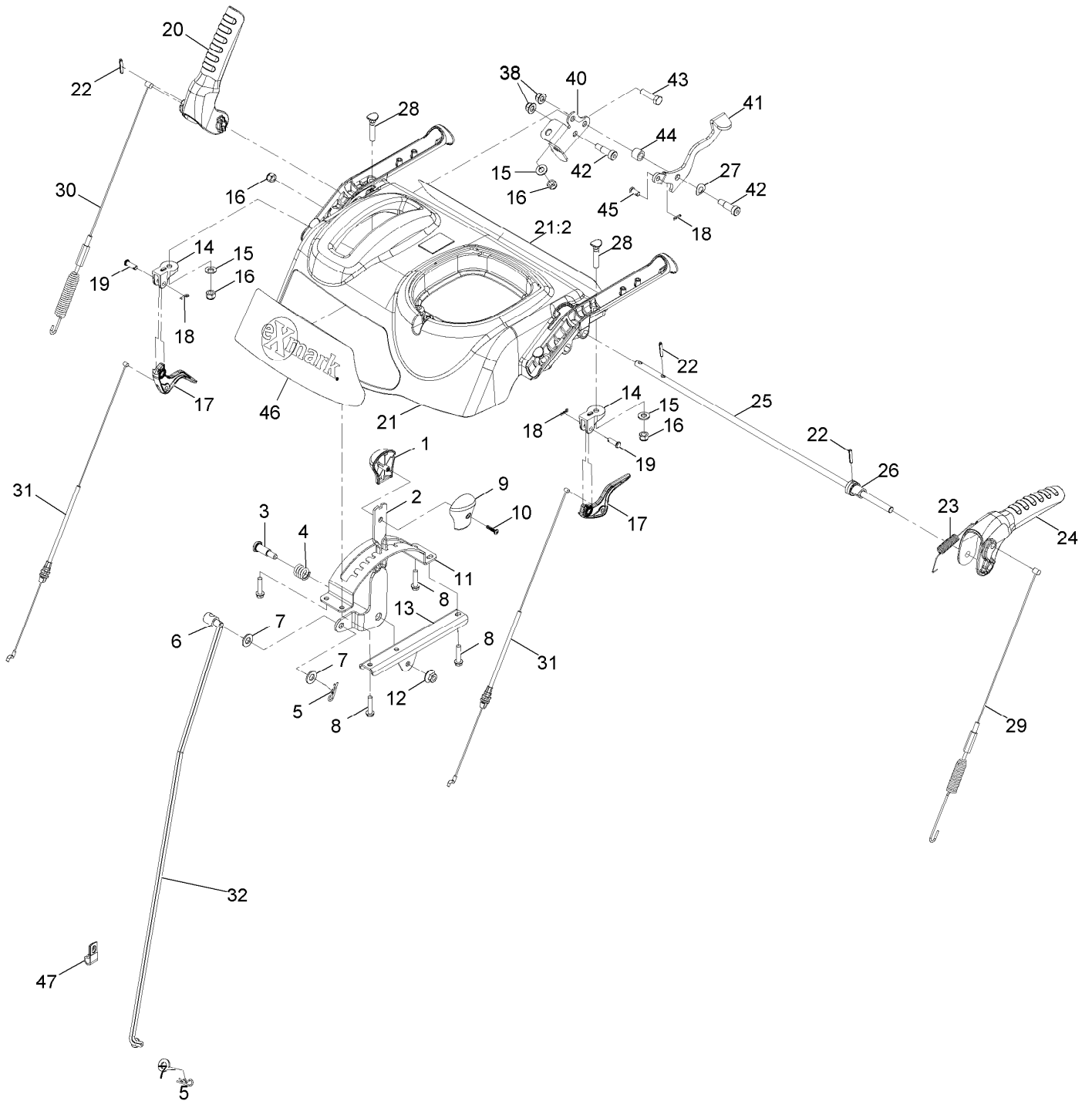

Control Panel Assembly (continued)

<i>Ref.</i>	<i>Part Number</i>	<i>Qty.</i>	<i>Description</i>	<i>Ref.</i>	<i>Part Number</i>	<i>Qty.</i>	<i>Description</i>
1	106-4423	1	Knob-Shift, RH	21:2	116-7668	1	Decal-Control Panel Back, Tss (CE Xb)
2	106-7278-03	1	Selector-Speed	22	32121-125	3	Pin-Spring
3	63-2650	1	Screw-Shoulder	23	136-7315	1	Spring-Tension
4	136-7121	1	Spring-Compression	24	106-4410	1	Lever-Traction
5	3290-307	2	Pin-Cotter	25	136-7100	1	Rod-Lockout
6	136-7193	1	Trunnion-Rod	26	107-1043	1	Cam-Lockout
7	3256-24	3	Washer-3/8 SAE	27	3290-212	1	Washer-Spring
8	46-8092	4	Screw-Plastite	28	107-3018	4	Screw-Handle
9	105-9999	1	Knob-Shift, LH	29	120-0132	1	Cable-Traction
10	94-4496	1	Screw-PPH	30	115-5685	1	Cable-Auger
11	106-7277-03	1	Guide-Selector, Speed	31	107-8896	2	Cable-Clutch
12	32128-13	1	Nut-HF	32	136-7109	1	Rod-Shift
13	130-9775-03	1	Bracket-Selector, Speed	38	104-8300	2	Nut-Nyloc 5/16-18 Flg
14	105-9980	2	Mount-Lever, Clutch	40	116-7669	1	Bracket-Lever, Broom Angle
15	3256-70	4	Washer-Flat	41	116-7670	1	Lever-Thumb, Broom Angle
16	3296-72	5	Nut-Nyloc 5/16-18	42	119-6915	2	Screw-Shoulder, HSH
17	106-4505	2	Lever-Clutch	43	322-6	1	Screw-HH 5/16-18 X 1 1/4
18	108-2992	3	Pin-Hair	44	116-7793	1	Tube-Spacer
19	1-808265	2	Pin-Clevis 1/4 X 3/4	45	146319	1	Pin-Clevis 1/4 X 1/2
20	106-4413	1	Lever-Auger	46	116-7786	1	Decal-Exmark Logo
21	116-7667	1	Panel, Control W/Decal CE Xb	47	1-323229	1	Clip-Loom 3/8

Handle Assembly

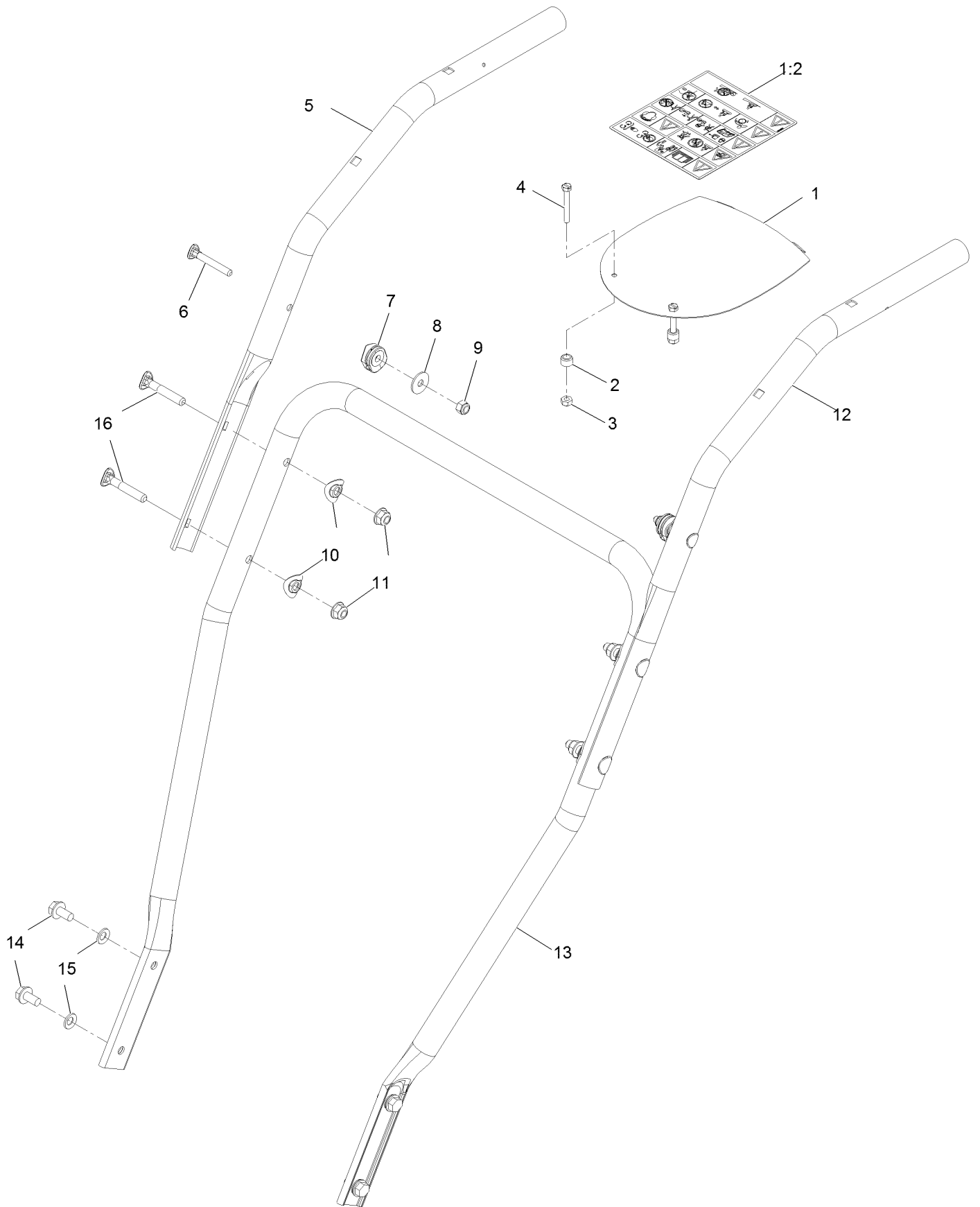

Handle Assembly (continued)

<i>Ref.</i>	<i>Part Number</i>	<i>Qty.</i>	<i>Description</i>	<i>Ref.</i>	<i>Part Number</i>	<i>Qty.</i>	<i>Description</i>
1	116-7788	1	Panel-Control	9	3296-73	2	Nut-Nyloc 1/4-20
1:2	135-2867	1	Decal-Console	10	107-3844	4	Washer
2	55-9370	2	Spacer-Blade, Rotor	11	104-8300	4	Nut-Nyloc 5/16-18 Flg
3	3296-2	2	Nut-Nyloc #10-24	12	127-5952-03	1	Handle-Upper, LH
4	32105-5	2	Screw	13	105-9981-03	1	Handle-Lower
5	127-5953-03	1	Handle-Upper, RH	14	32144-14	4	Screw-HWHTF
6	95-4453	2	Screw	15	3290-475	4	Washer-Belleville
7	106-4509	2	Clamp-Cable	16	92-2260	4	Screw-Handle
8	87-6630	2	Washer-Plain				

Engine Assembly

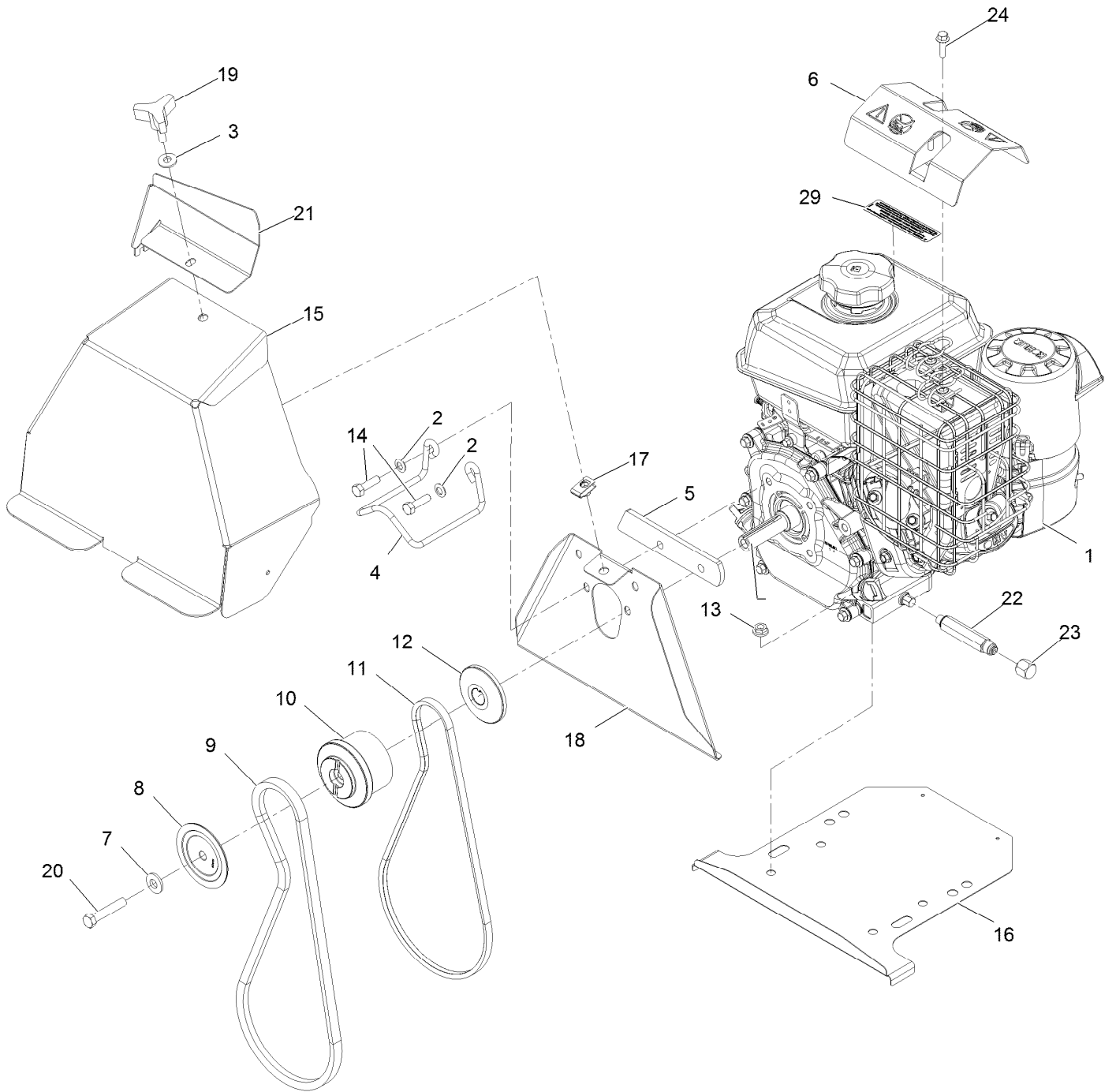

Engine Assembly (continued)

<i>Ref.</i>	<i>Part Number</i>	<i>Qty.</i>	<i>Description</i>	<i>Ref.</i>	<i>Part Number</i>	<i>Qty.</i>	<i>Description</i>
1		1	Engine-Kohler, Ch270 ●▲	14	3210-6	2	Bolt-HH 5/16-24 X 1 1/8
2	3290-475	2	Washer-Belleville	15	116-7258-03	1	Cover - Belt
3	1-303334	1	Washer-Spring Disc 5/16	16	116-8761-03	1	Shield-Drive
4	136-7317	1	Guide-Belt	17	94-2413	1	Nut-U
5	116-7659-03	1	Spacer-Cover, Belt	18	116-7431-03	1	Cover-Belt, Back
6	126-4178-03	1	Deflector-Debris, Muffler	19	106-2240	1	Knob
7	98-5975	1	Washer-Spring Disc 3/8	20	3211-9	1	Screw-HH ◆
8	112-8139	1	Sheave-Half, Impeller ■	21	116-7922-03	1	Shield-Ice, Kc Ch270
9	1-653332	1	Belt	22	116-8721	1	Adapter
10	112-8117	1	Pulley-Engine, Center ■	23	01-201-4520	1	Cap
11	94-8812	1	V Belt-Traction	24	33103-025	2	Screw-HHF
12	112-8138	1	Sheave-Half, Traction ■	29	133-8062	1	Decal-Arrestor, Spark
13	32128-20	4	Nut-Whizlock 5/16-18				

● Not serviced separately

▲ Obtain parts from www.kohlerplus.com

◆ Use Pro-Lock, Nut Type (P/N 1-840022, .5ml tube) on threads.

■ Apply anti-seize compound in bore.

Broom Head and Shield Assembly

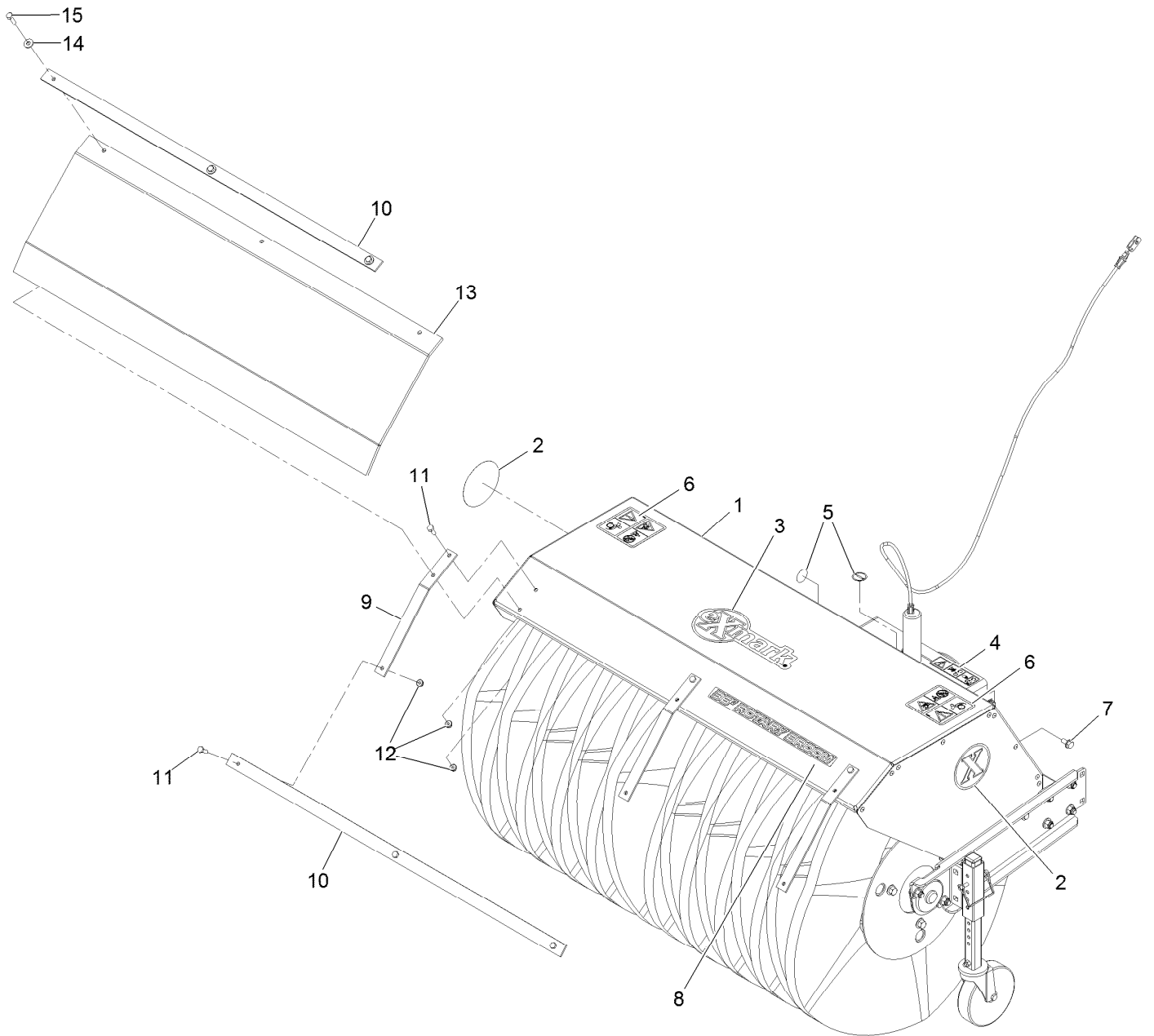

Broom Head and Shield Assembly (continued)

<i>Ref.</i>	<i>Part Number</i>	<i>Qty.</i>	<i>Description</i>	<i>Ref.</i>	<i>Part Number</i>	<i>Qty.</i>	<i>Description</i>
1		1	Broom ASM ●	9	116-8869-03	3	Strap-Support, Deflector
2	116-7034	2	Decal-Exmark X-Logo 3.85	10	116-8880-03	2	Strap-Support, Broom Deflector
3	1-653546	1	Decal, Exmark	11	321-4	6	Screw-HH 1/4-20 X 3/4
4	112-9028	1	Decal-Cover, Missing	12	104-7201	9	Nut-Nyloc 1/4-20 Flg
5	115-2903	2	Decal-Grease	13	116-8864	1	Deflector-Broom
6	116-8140	2	Decal-Warning	14	3256-2	3	Washer-1/4 Std
7	32144-14	6	Screw-HWHTF	15	321-6	3	Screw-HH 1/4-20 X 1
8	116-9227	1	Decal-36 Rotary Broom				

● Not serviced separately

Mounting Assembly

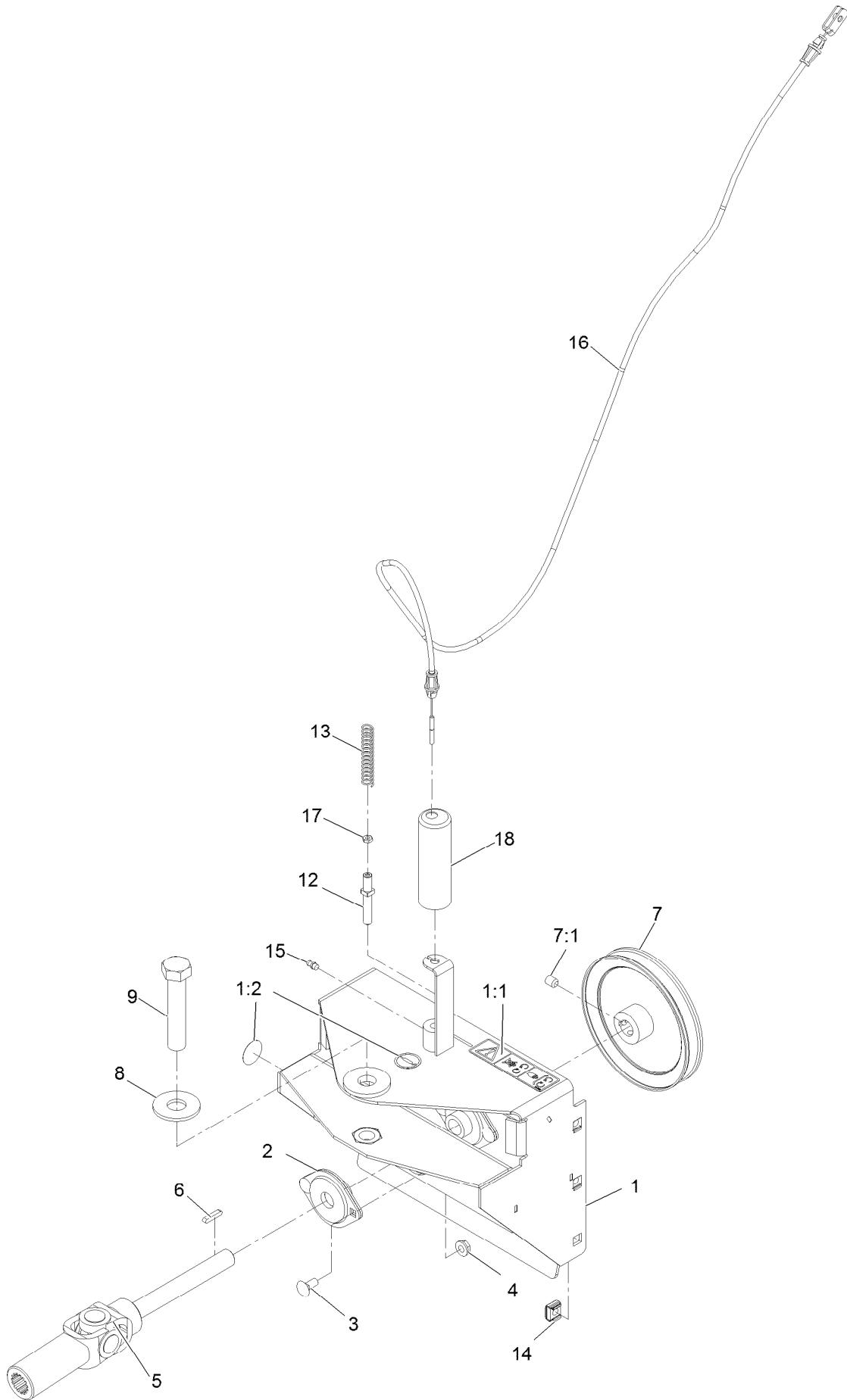

Mounting Assembly (continued)

<i>Ref.</i>	<i>Part Number</i>	<i>Qty.</i>	<i>Description</i>	<i>Ref.</i>	<i>Part Number</i>	<i>Qty.</i>	<i>Description</i>
1	116-8122	1	Broom Mounting Frame ASM	7:1	3246-18	2	Setscrew-5/16-18 X 3/8
1:1	112-9028	1	Decal-Cover, Missing	8	3256-8	1	Washer
1:2	115-2903	2	Decal-Grease	9	3216-7	1	Screw-HH 3/4-16 X 3 3/4
2	116-8103	2	Bearing-Shaft	12	116-8106	1	Pin-Swing
3	3230-1	4	Bolt-Carriage 5/16-18 X 3/4	13	116-8107	1	Spring-Compression
4	32128-20	4	Nut-Whizlock 5/16-18	14	3290-496	6	Nut-Retainer
5	116-8104	1	Shaft-Drive	15	302-19	1	Zerk-1/4-28 Str
6	116-8105	1	Key-Round End	16	116-7671	1	Cable-Angle, Broom
7	116-7930	1	Pulley-Impeller	17	3217-26	1	Nut-Hex
				18	116-8108	1	Cap

Hood and Frame Assembly

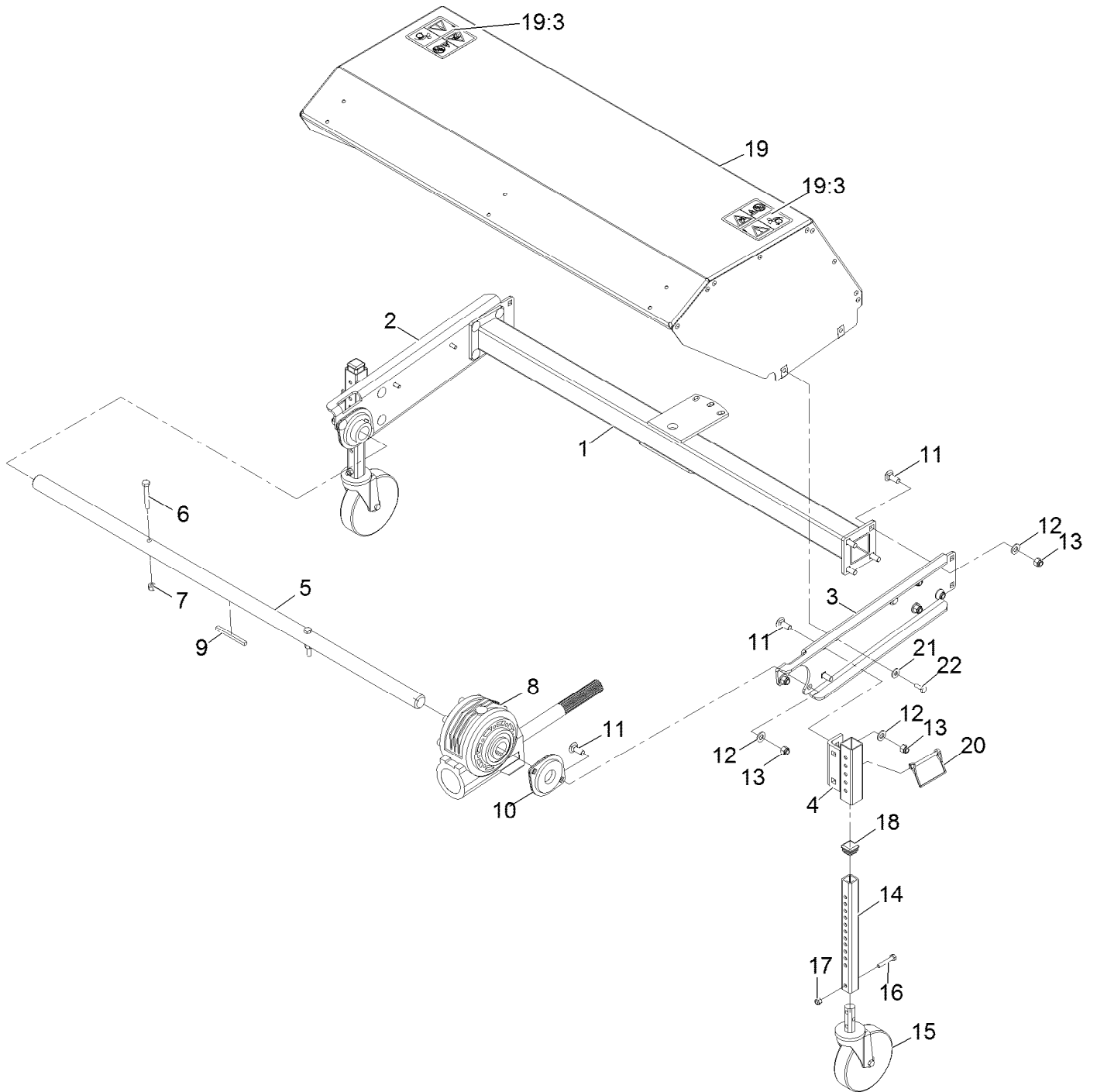

Hood and Frame Assembly (continued)

<i>Ref.</i>	<i>Part Number</i>	<i>Qty.</i>	<i>Description</i>	<i>Ref.</i>	<i>Part Number</i>	<i>Qty.</i>	<i>Description</i>
1	116-8544	1	Frame	13	3296-39	16	Nut-Nyloc 3/8-16
2	116-8546	1	Arm-Right	14	116-8223	2	Tube-Square, Height Adjust
3	116-8545	1	Arm-Left	15	116-8117	2	Caster-Wheel
4	116-8543	2	Caster-Bracket	16	321-9	2	Screw-HH 1/4-20 X 1 1/2
5	116-8114	1	Shaft	17	3296-42	2	Nut-Nyloc 1/4-20
6	322-11	2	Screw-HH 5/16-18 X 2 1/4	18	103-3202	2	Cap
7	3296-29	2	Nut-Nyloc 5/16-18	19	116-8123	1	Broom Hood ASM
8	116-8115	1	Gearbox-Worm	19:3	116-8140	2	Decal-Warning
9	83-2800	1	Key-Straight	20	116-8224	2	Pin-Wire, Lock
10	116-8116	2	Bearing-Flange	21	3256-2	4	Washer-1/4 Std
11	3231-2	16	Bolt-Carriage 3/8-16 X 1	22	321-4	4	Screw-HH 1/4-20 X 3/4
12	3256-24	16	Washer-3/8 SAE				

Core Assembly

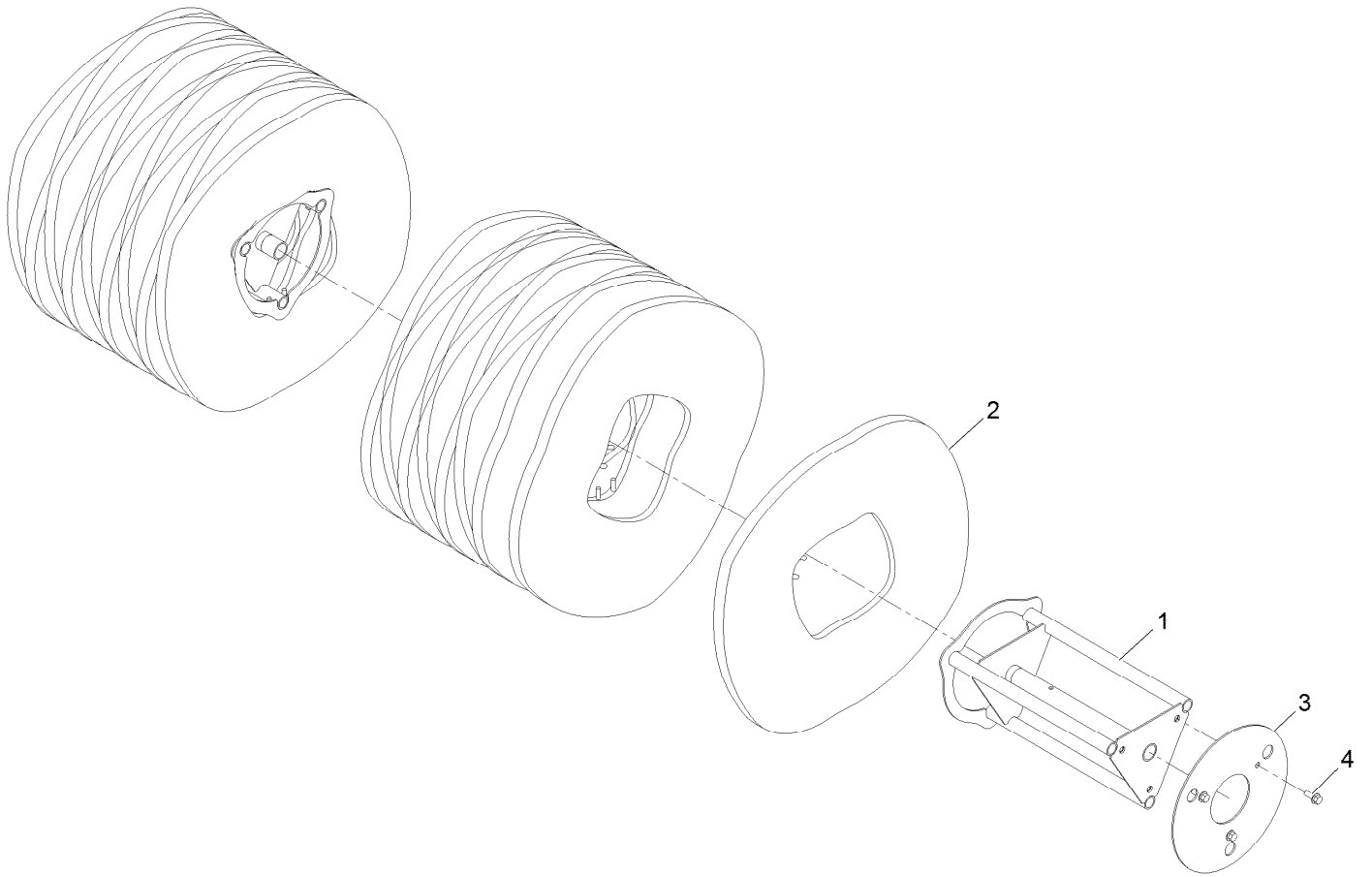

Core Assembly (continued)

<i>Ref.</i>	<i>Part Number</i>	<i>Qty.</i>	<i>Description</i>	<i>Ref.</i>	<i>Part Number</i>	<i>Qty.</i>	<i>Description</i>
1	116-8119	2	Core-Broom	3	116-8121	2	Plate-End, Retainer
2	116-8120	18	Segment-Poly	4	3234-11	6	Screw-HH Flg 3/8-16 X 1

EXMARK ACCESSORIES AND OPTIONS*

MID-MOUNT RIDING ACCESSORIES AND OPTIONS

CUSTOM RIDE SEAT SUSPENSION SYSTEM	OPERATOR CONTROLLED DISCHARGE
FULL SUSPENSION SEAT	SUN SHADE
DECK LIFT ASSIST KIT	TRASH CONTAINER
HITCH KIT	TURF STRIPER
LIGHT KIT	ULTRA VAC COLLECTION SYSTEM
12V POWER PORT	ULTRA VAC QUICK DISPOSAL SYSTEM
MICRO-MULCH SYSTEM	

OUT-FRONT RIDING ACCESSORIES AND OPTIONS

CUSTOM RIDE SEAT SUSPENSION SYSTEM	SNOW BLADE
DUAL-TAIL WHEEL	SNOWBLOWER
FLOOR PAN EXTENDER	SUN SHADE
HITCH KIT	TRASH CONTAINER
LIGHT KIT	ULTRA VAC COLLECTION SYSTEM
MICRO-MULCH SYSTEM	ULTRA VAC QUICK DISPOSAL SYSTEM
ROLL OVER PROTECTION SYSTEM (ROPS)	WEATHER CAB

WALK-BEHIND ACCESSORIES AND OPTIONS

GRASS CATCHER	TURF STRIPER
MICRO-MULCH SYSTEM	STANDON

*Some accessories and options not available for some models.

Place Model No. and Serial No.
Label Here (Included in the Literature
Pack) or Fill in Below

Model No. _____

Serial No. _____

Date Purchased _____

Engine Model No. and Spec. No. _____

Engine Serial No. (E/No) _____

© 2018 Exmark Mfg. Co., Inc.
2101 Ashland Ave
Beatrice, NE 68310
All Rights Reserved

Part No. 4504-204 Rev. A
(402) 223-6375
Fax (402) 223-5489
Printed in the USA.

