

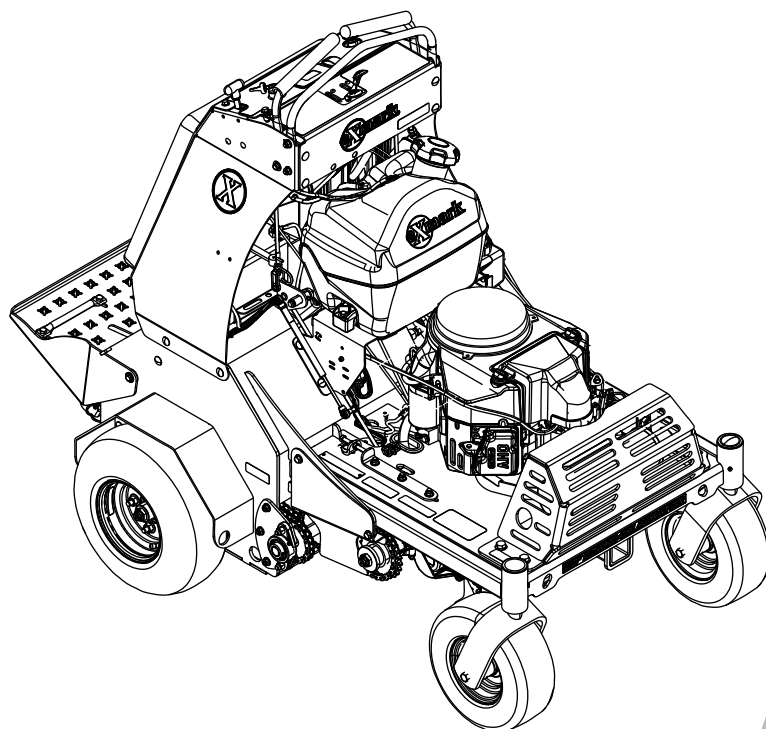

AERATOR 30

Model No. ARX541CKA30000—Serial No. 404314159 and Up

Picture below may not reflect actual product.



Parts Manual

Part No. 4504-203 Rev. A

Ordering Replacement Parts

To order replacement parts, please supply the part number, the quantity, and the description of each part desired.

Understanding Reference Numbers

Each identified part in an illustration has a reference number. The reference number for a part also appears in the parts list, along with other information about the part.

This catalog uses two special reference number formats, one to indicate parts in a service assembly and another to indicate the quantity of a given part in an illustration.

Service Assembly Reference Numbers

Parts in service assemblies have reference numbers in the form a:b. The a represents the reference number of the entire service assembly and the b represents a sequential number unique to each part within the service assembly.

For example, a wheel assembly might be identified by reference number 6, the tire by 6:1, the valve by 6:2, and the wheel by 6:3. When you order the assembly identified by reference number 6, you receive all parts identified by reference numbers 6:1, 6:2, and 6:3. However, you may also order any part individually. Reference numbers of this type appear in illustration and in parts lists.

Reference Numbers Indicating Quantity

In an illustration, if a reference number indicates more than one part, the reference number has the form nX y. The n represents the quantity of the part, the X is the multiplication symbol, and the y represents the reference number.

For example, in an illustration, the reference number 2X 37 means that two of the parts identified by reference number 37 are indicated.

Touch Up Paint

Exmark black touch up spray paint – gloss black.

Exmark red touch up paint (spray paint – P/N 1-850337 - .6 oz liquid bottle – P/N 103-9140).



If your Exmark dealer does not have the Exmark part in stock, Exmark will get the parts to the dealer the next business day or the part will be FREE Guaranteed!! (Some restrictions apply. See your participating Exmark Dealer for details.)

Contents

Main Frame Assembly	4
Main Frame Decal Assembly	6
Caster Wheel and Fork Assembly	8
Platform and Rocker Assembly	10
Tower Assembly	12
Motion Control Assembly	14
Fuel Assembly	16
Auxiliary Hydraulic Assembly	18
Engine Assembly	20
Ground Drive Assembly	22
Idler Arm Assembly No. 116-9307	24
LH Transaxle Assembly No. 135-1051	26
RH Transaxle Assembly No. 135-1050	28
Axle and Bearing Assembly No. 116-9545	30
Tine Assembly	32
LH Tine Wheel Assembly No. 135-2510	34
RH Tine Wheel Assembly No. 135-2507	36
Electrical Assembly	38

Main Frame Assembly

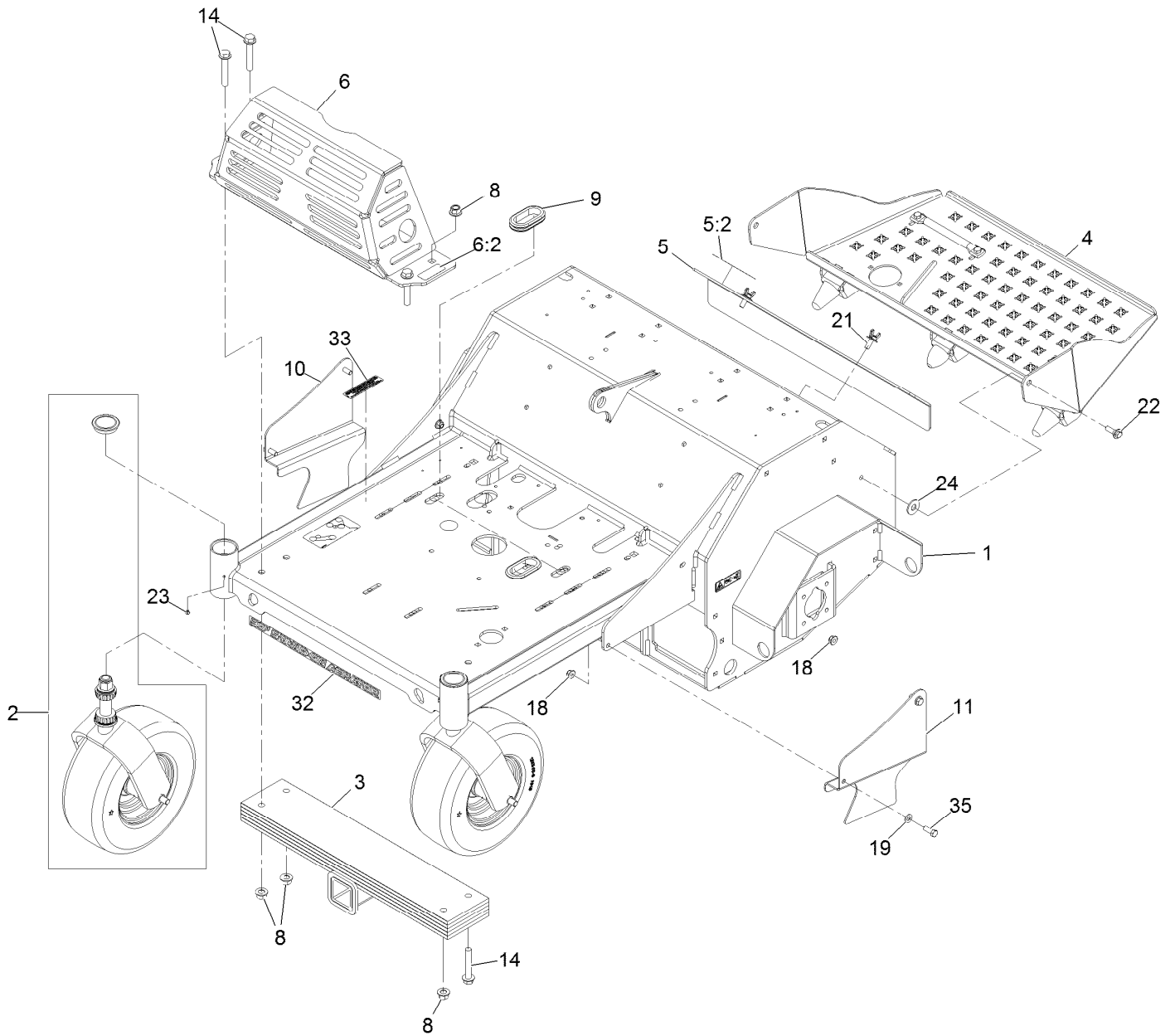

Main Frame Assembly (continued)

<i>Ref.</i>	<i>Part Number</i>	<i>Qty.</i>	<i>Description</i>	<i>Ref.</i>	<i>Part Number</i>	<i>Qty.</i>	<i>Description</i>
1	135-5938	1	Main Frame ASM	11	116-6611-01	1	Guard-Chain, LH
2		2	Front Caster ASM W/Fork ●	14	3234-40	4	Screw-HF
3	116-6536-01	1	Weight	18	104-8301	6	Nut-Nyloc 3/8-16 Flg
4	116-9134	1	Platform ASM W/Decal & Rocker	19	3256-24	4	Washer-3/8 SAE
5	116-7300	1	Access Cover ASM	21	135-4629	2	Screw-Sems (3/8-16 X 1)
5:2	121-6163	1	Decal-Operation, Tine Ground (CE)	22	614672	2	Screw-Shoulder 3/8-16 X 1.295
6	116-8258	1	Muffler Guard ASM	23	1-811010	2	Plug
6:2	115-2047	2	Decal-Surface, Hot	24	3256-6	2	Washer
8	99-5107	4	Nut-Lock 1/2-13	32	126-7033	1	Decal-Aerator 30 Logo
9	126-0015	2	Grommet	33	133-8062	1	Decal-Arrestor, Spark
10	116-6612-01	1	Guard-Chain, RH	35	323-6	4	Screw-HH 3/8-16 X 1

● Not serviced separately

Main Frame Decal Assembly

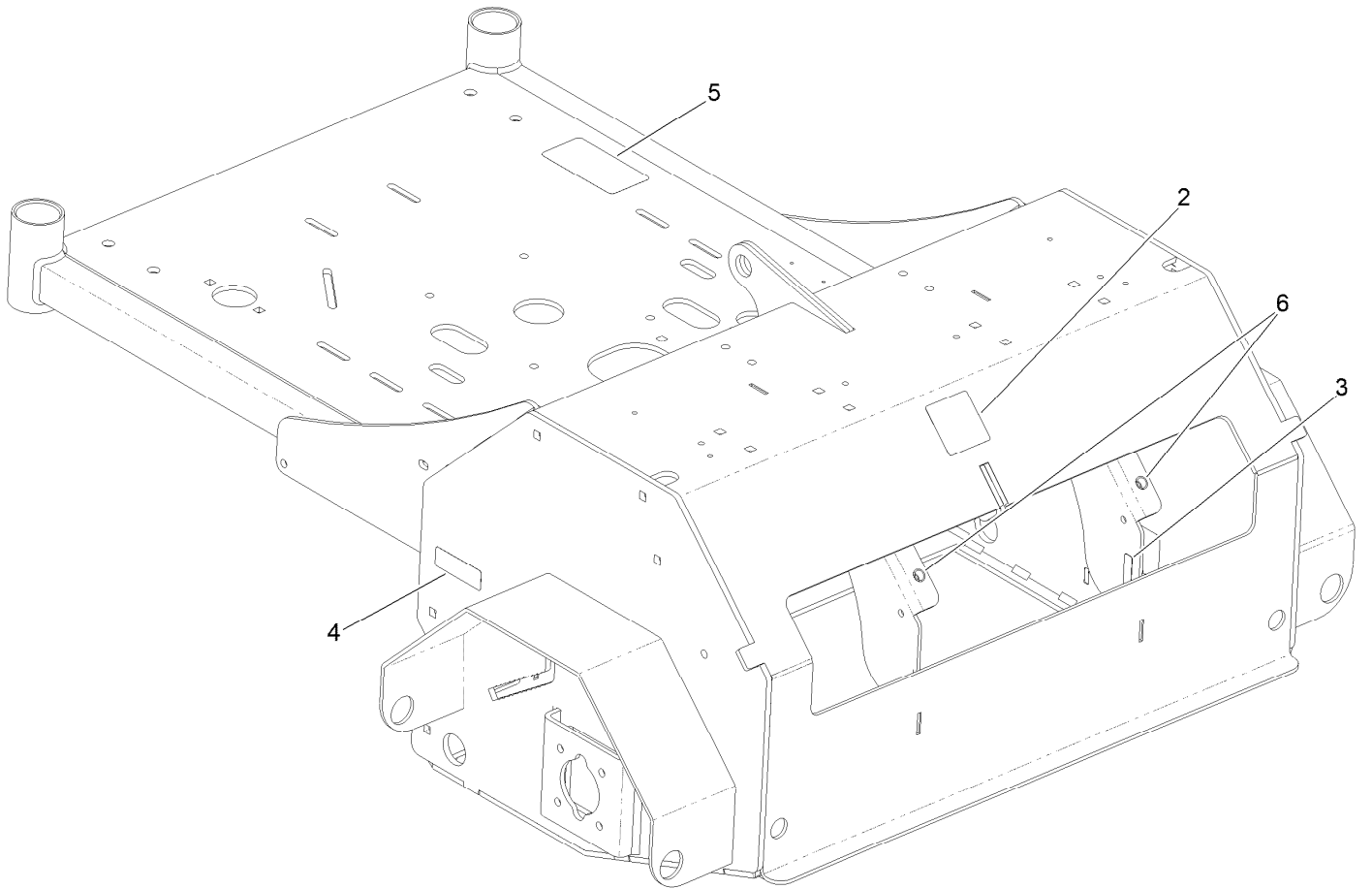

Main Frame Decal Assembly (continued)

<i>Ref.</i>	<i>Part Number</i>	<i>Qty.</i>	<i>Description</i>	<i>Ref.</i>	<i>Part Number</i>	<i>Qty.</i>	<i>Description</i>
2	121-6150	1	Decal-Warning	5	116-9391	1	Decal-Routing, Belt
3	120-9570	1	Decal-Warning	6	32148-10	2	Nut-Clinch
4	121-6161	2	Decal-Danger				

Caster Wheel and Fork Assembly

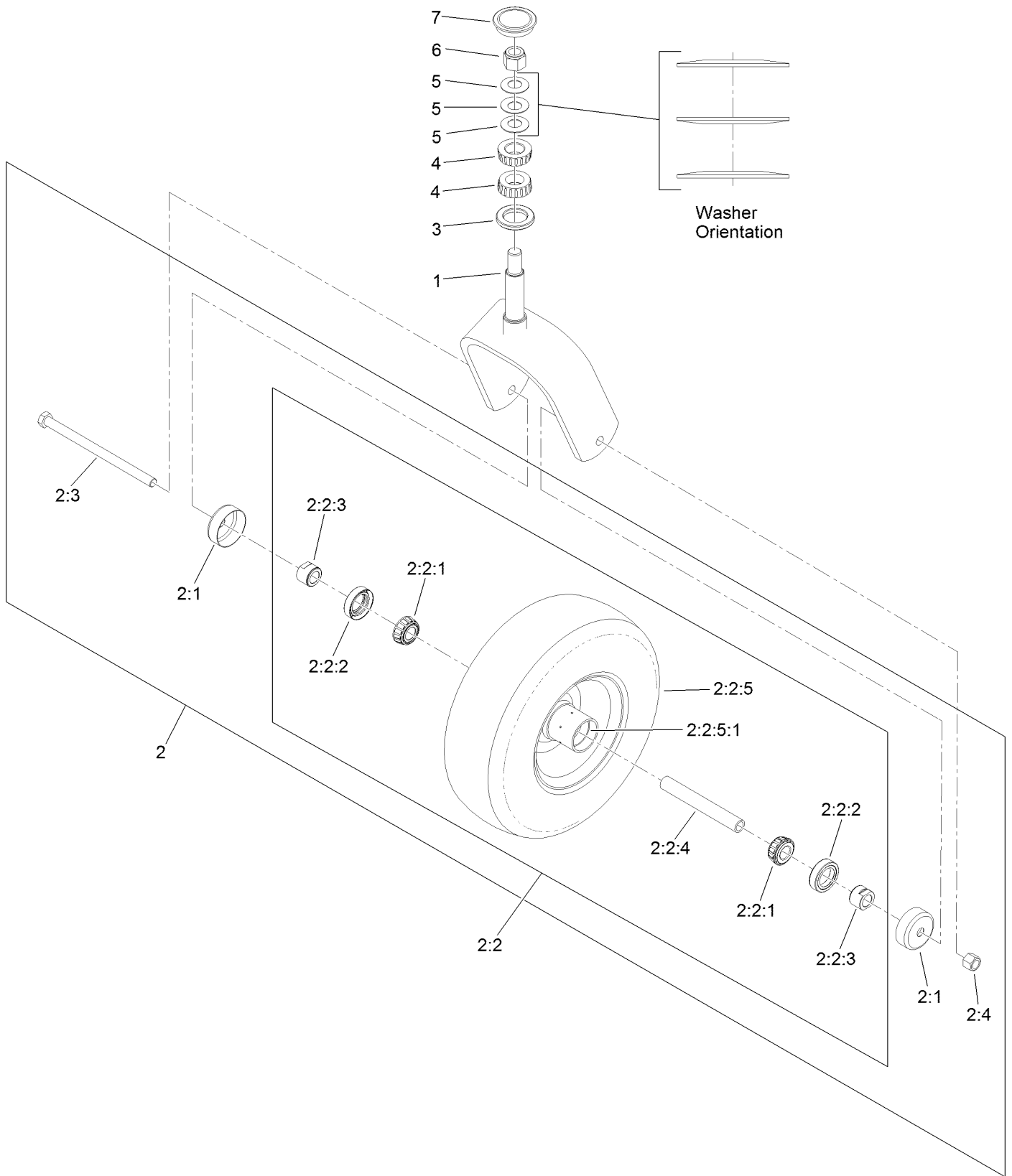

Caster Wheel and Fork Assembly (continued)

<i>Ref.</i>	<i>Part Number</i>	<i>Qty.</i>	<i>Description</i>	<i>Ref.</i>	<i>Part Number</i>	<i>Qty.</i>	<i>Description</i>
1	116-6704-01	1	Caster	2:2:5:1	1-633584	2	Bearing-Cup
2	109-9126	1	Wheel & Tire ASM	2:3	325-42	1	Screw-HH
2:1	103-2768	2	Guard-Seal	2:4	3296-23	1	Nut-Lock, NI
2:2		1	Wheel And Tire ASM ●	3	116-5647	1	Seal-Grease
2:2:1	1-633585	2	Bearing-Cone, Taper	4	1-543509	2	Bearing-Roller, Tapered
2:2:2	103-0063	2	Seal-Caster	5	1-633508	3	Washer-Bellville
2:2:3	103-3051	1	Spacer-Nut ■	6	3296-51	1	Nut-Lock, NI
2:2:4	126-5360	1	Axle-Caster	7	103-4882	1	Cap-Grease
2:2:5		1	Wheel And Tire ASM ●				

● Not serviced separately

■ Use Pro-Lock, Nut Type (P/N 1-840022, .5ml tube) on threads.

Platform and Rocker Assembly

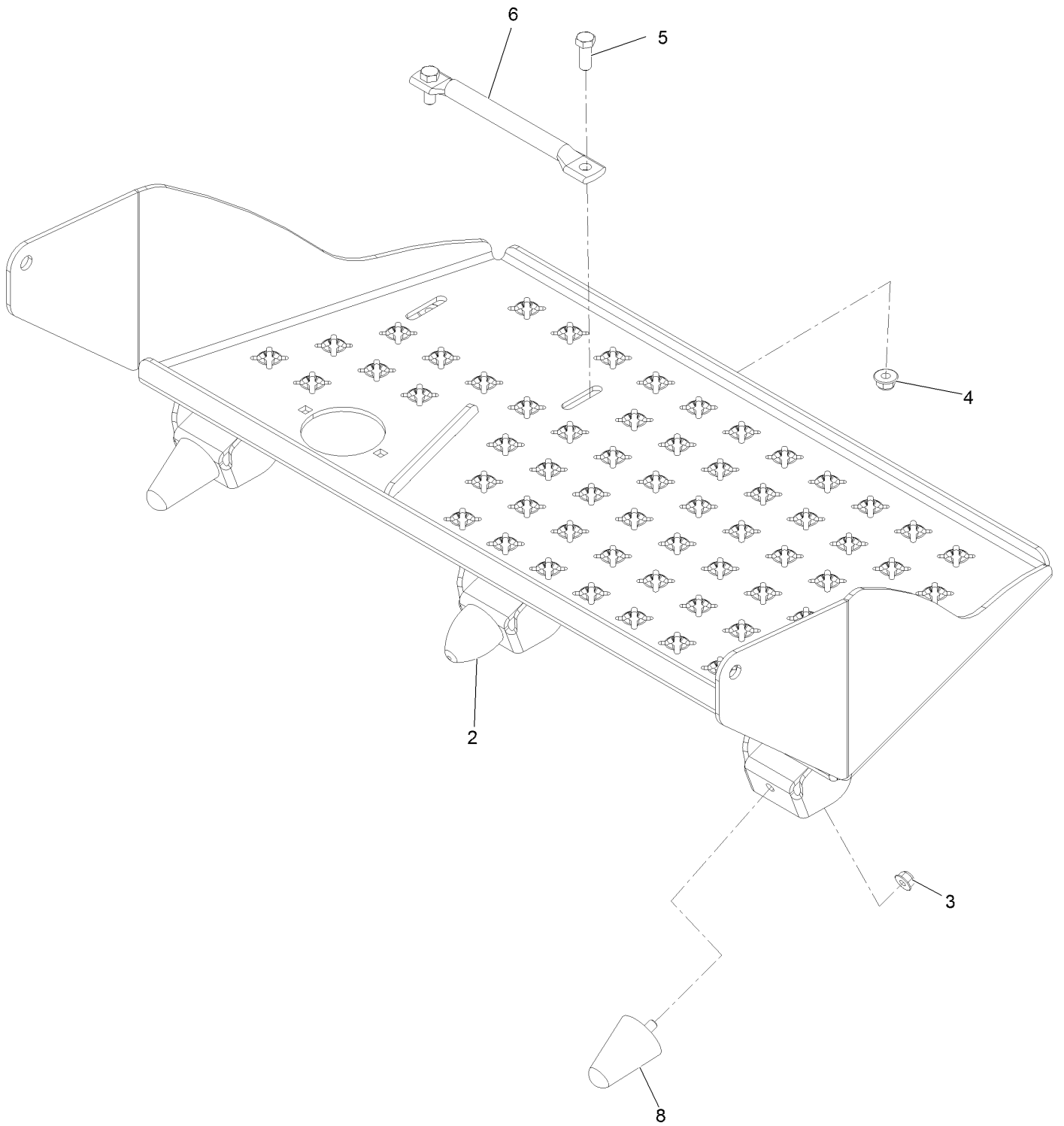

Platform and Rocker Assembly (continued)

<i>Ref.</i>	<i>Part Number</i>	<i>Qty.</i>	<i>Description</i>	<i>Ref.</i>	<i>Part Number</i>	<i>Qty.</i>	<i>Description</i>
2	114-1926	1	Bumper-Rubber	5	323-6	2	Screw-HH 3/8-16 X 1
3	104-8300	3	Nut-Nyloc 5/16-18 Flg	6	116-8950-03	1	Rocker-Foot Pedal
4	104-8301	2	Nut-Nyloc 3/8-16 Flg	8	114-1925	2	Bumper-Rubber

Tower Assembly

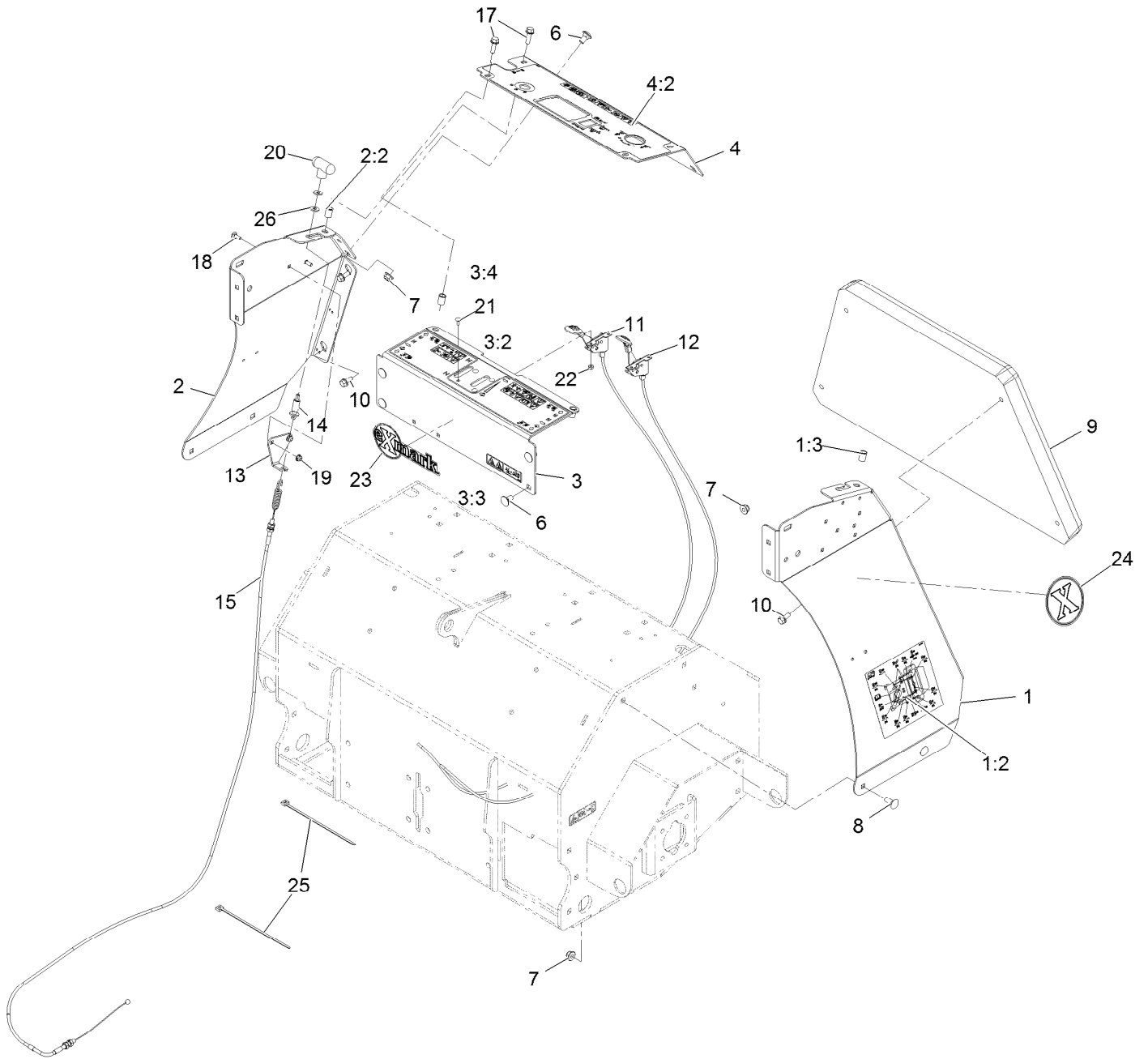

Tower Assembly (continued)

<i>Ref.</i>	<i>Part Number</i>	<i>Qty.</i>	<i>Description</i>	<i>Ref.</i>	<i>Part Number</i>	<i>Qty.</i>	<i>Description</i>
1	135-5945	1	Panel-Side, LH W/Decals-Black	10	3234-5	4	Screw-HH Flg 5/16-18 X 3/4
1:2	116-9392	1	Decal-Service Aid (CE)	11	109-9147	1	Control-Choke
1:3	32148-7	1	Nut-Clinch	12	109-3958	1	Control-Throttle
2	116-7658	1	ASM-Panel,Side RH (Black)	13	116-6630	1	Bracket-Cable, Brake
2:2	32148-7	1	Nut-Clinch	14	116-7504	1	Link-Cable, Brake
3	135-6294	1	ASM-Plate W/Decal	15	116-7503	1	Cable-Brake
3:2	121-6164	1	Decal-Warning, Control Panel	17	3234-29	4	Screw-HH Flg 5/16-18 X 1
3:3	121-6162	1	Decal-Warning, Tines	18	3229-1	2	Bolt-Carriage 1/4-20 X 3/4
3:4	32148-7	2	Nut-Clinch	19	104-7201	2	Nut-Nyloc 1/4-20 Flg
4	135-5947	1	ASM-Panel W/Decals	20	116-7607	1	Knob-Tee
4:2	135-5948	1	Decal-Panel, Control	21	1-807513	4	Bolt-Carriage #10-24 X 1/2
6	3231-1	6	Bolt-Carriage 3/8-16 X 3/4	22	3296-2	4	Nut-Nyloc #10-24
7	104-8301	10	Nut-Nyloc 3/8-16 Flg	23	126-6877	1	Decal, Exmark Logo
8	3231-2	4	Bolt-Carriage 3/8-16 X 1	24	126-7457	2	Decal-X-Logo
9	116-6765	1	Cushion, Grey	25	1-303335	2	Tie-Cable 7 15/16 (Large)
				26	3256-2	2	Washer-1/4 Std

Motion Control Assembly

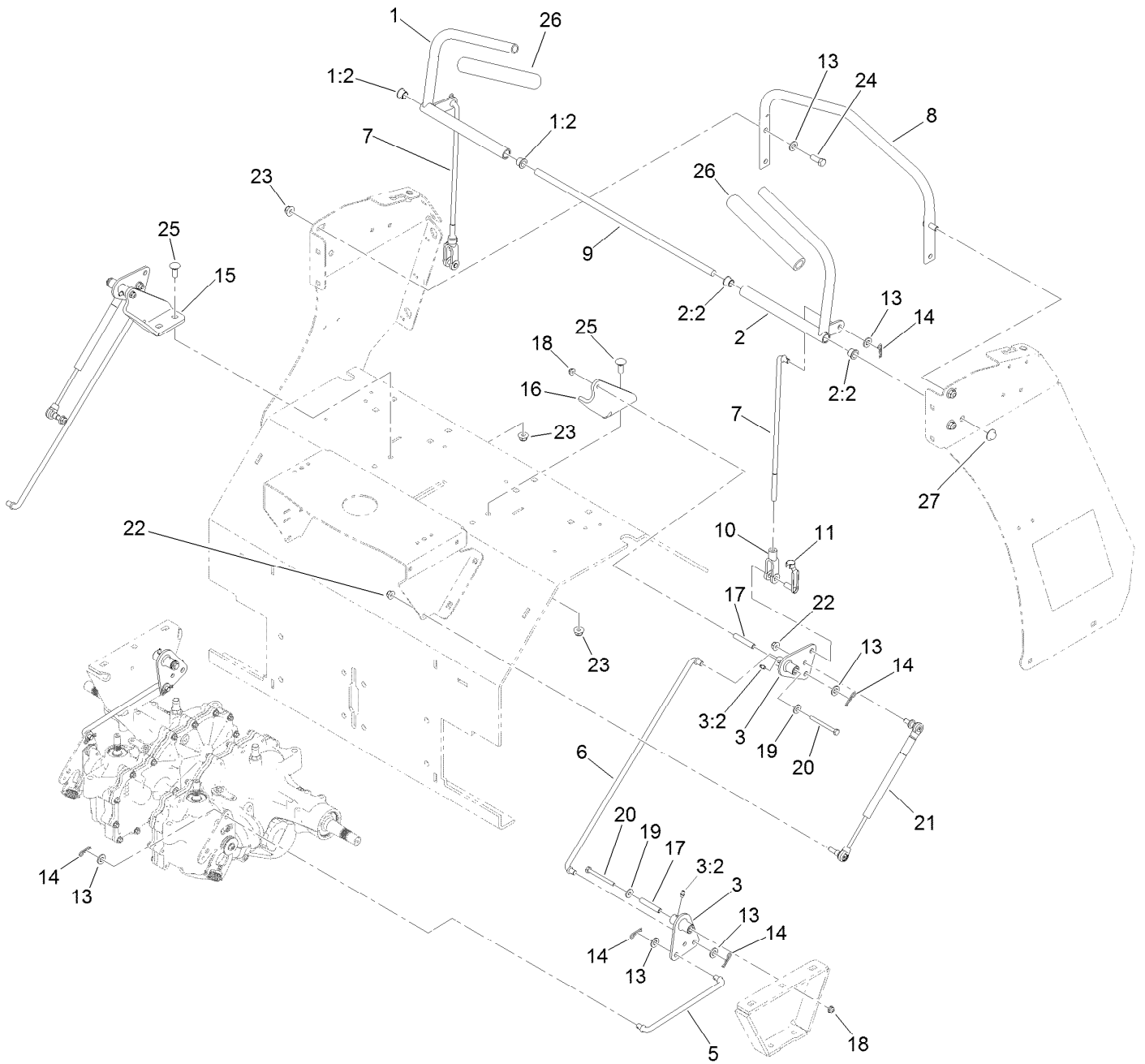

Motion Control Assembly (continued)

<i>Ref.</i>	<i>Part Number</i>	<i>Qty.</i>	<i>Description</i>	<i>Ref.</i>	<i>Part Number</i>	<i>Qty.</i>	<i>Description</i>
1	116-6567	1	RH Control Handle ASM	14	1-806003	10	Pin-Cotter
1:2	116-4279	2	Bearing-Flange	15	116-6576-03	1	Bracket-Pivot, RH
2	116-6566	1	LH Control Handle ASM	16	116-6577-03	1	Bracket-Pivot, LH
2:2	116-4279	2	Bearing-Flange	17	116-7224	4	Spacer
3	126-0340	4	Crank-Bell	18	104-7201	4	Nut-HF
3:2	302-19	1	Fitting-Grease	19	3256-2	4	Washer-Flat
5	116-6722	2	Link-Control, Hydro	20	321-14	4	Screw-HH
6	116-9298	2	Link-Control, Bell Crank	21	116-0027	2	Damper-Control, Motion
7	116-6730	2	Link-Control, Bell Crank	22	104-8300	4	Nut-HF, NI
8	116-6608-03	1	Bar-Reference	23	104-8301	8	Nut-HF, NI
9	116-6607	1	Shaft-Pivot, Control	24	323-6	4	Screw-HH
10	1-633131	2	Yoke-Linkage, Brake	25	3231-2	4	Bolt-CARR
11	103-2399	2	Pin-Spring, Clevis	26	103-8153	2	Grip-Lever, Control
13	3256-24	14	Washer-Flat	27	32112-14	2	Nut-Push

Fuel Assembly

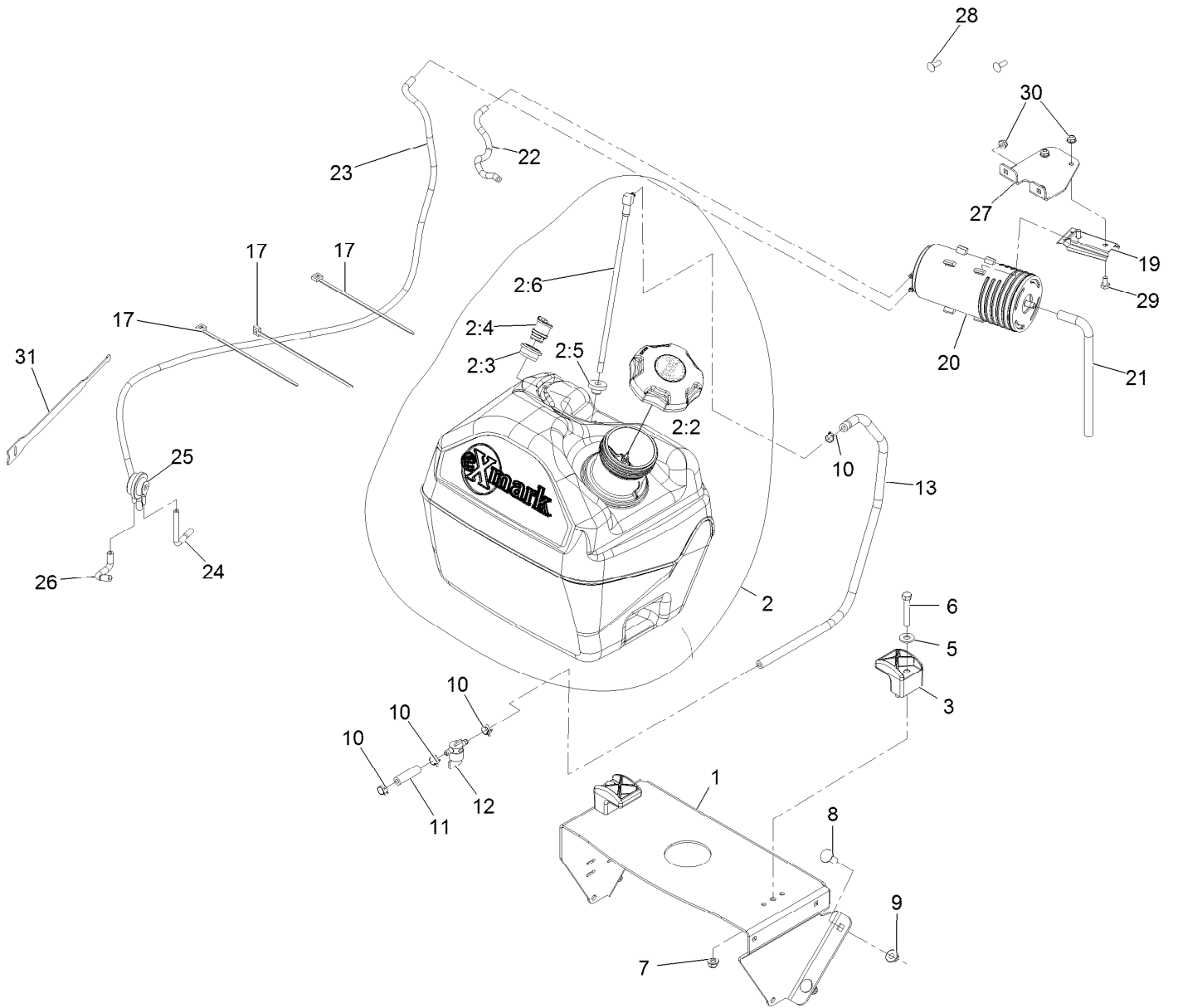

Fuel Assembly (continued)

<i>Ref.</i>	<i>Part Number</i>	<i>Qty.</i>	<i>Description</i>	<i>Ref.</i>	<i>Part Number</i>	<i>Qty.</i>	<i>Description</i>
1	116-9541-01	1	Support-Tank, Fuel	12	1-603770	1	Valve-Fuel
2	135-2855	1	ASM, Fuel Tank 5 Gal	13	135-0494	1	Hose-Line, Gas
2:2	137-4119	1	Cap-Fuel, Ratcheting	17	1-303335	3	Tie-Cable 7 15/16 (Large)
2:3	114-0284	1	Grommet	19	114-0292	1	Bracket-Canister, Carbon
2:4	119-3547	1	Valve-Vent, Fuel	20	117-1221	1	Canister-Carbon, 800Cc
2:5	46-6560	1	Bushing	21	115-0962	1	Hose-Vent, Canister
2:6	109-9364	1	Fitting-Fuel (W/Line And Screen)	22	135-0986	1	Hose-Emissions
3	107-4543	2	Clamp	23	126-4179	1	Hose-Vent, Formed
5	3256-3	2	Washer-5/16 Std	24	119-8501	1	Hose-Vent, Formed
6	322-10	2	Screw-HH 5/16-18 X 2	25	116-2232	1	Valve-Control, Vacuum
7	104-8300	2	Nut-Nyloc 5/16-18 Flg	26	119-8502	1	Hose-Vent, Formed
8	3231-22	4	Bolt-Carriage 3/8-16 X 1	27	126-2991-03	1	Bracket-Mounting, Canister
9	104-8301	4	Nut-Nyloc 3/8-16 Flg	28	3229-1	2	Bolt-Carriage 1/4-20 X 3/4
10	2412-98	4	Clamp-Hose	29	321-2	2	Screw-HH 1/4-20 X 1/2
11	119-7856	1	Hose-Fuel	30	104-7201	4	Nut-Nyloc 1/4-20 Flg
				31	116-2469	1	Strap-Velcro, Cable Tie

Auxiliary Hydraulic Assembly

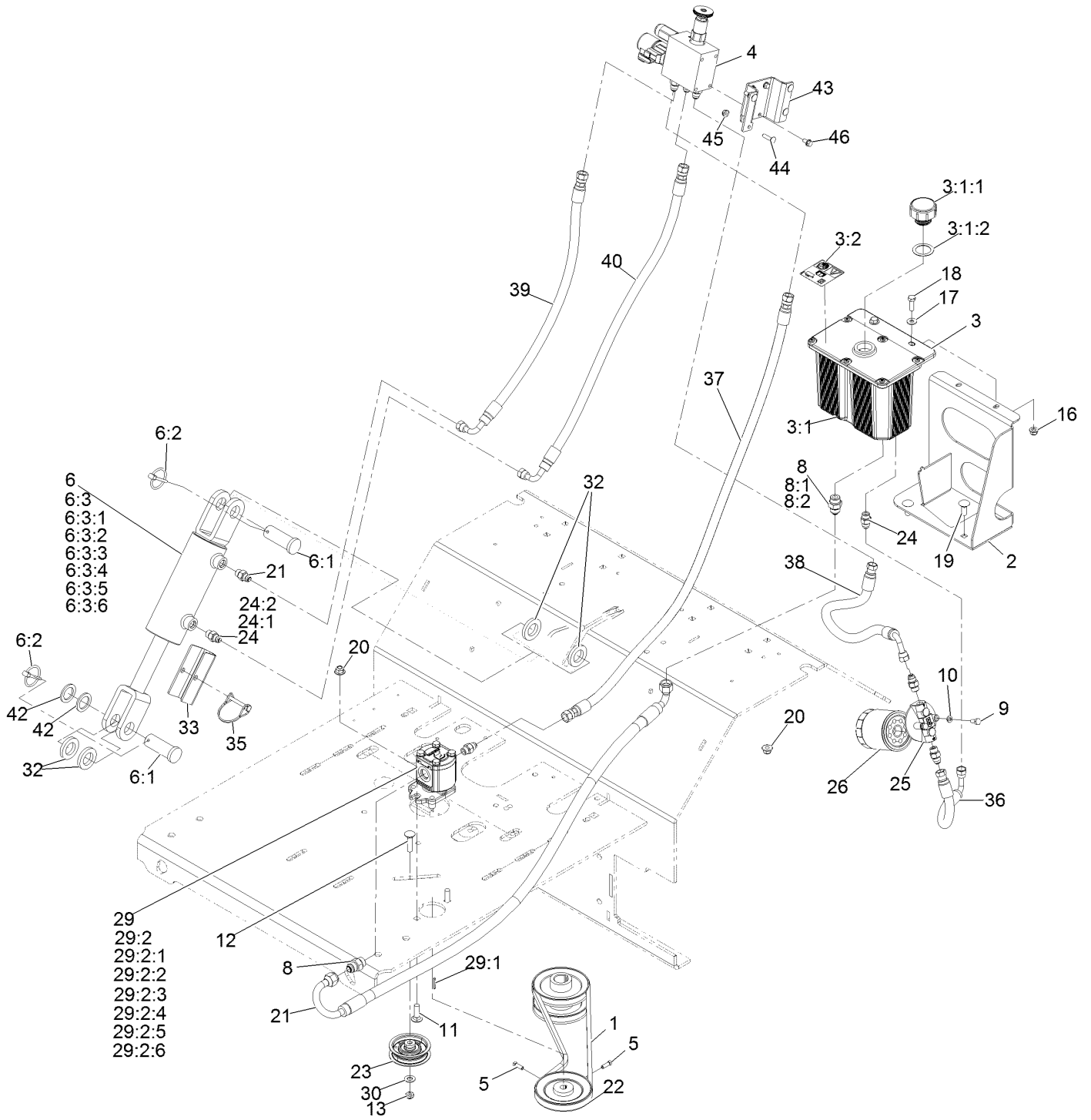

Auxiliary Hydraulic Assembly (continued)

<i>Ref.</i>	<i>Part Number</i>	<i>Qty.</i>	<i>Description</i>	<i>Ref.</i>	<i>Part Number</i>	<i>Qty.</i>	<i>Description</i>
1	116-8874	1	Belt-4L Section	21	116-9309	1	Hose-Hydraulic
2	116-6618-03	1	Bracket-Tank, Hydraulic	22	116-6667	1	Pulley
3	116-7557	1	Reservoir ASM	23	116-6760	1	Pulley-Idler, Flat
3:1		1	Tank-Hydraulic ●	24	103-2156	6	Adapter-Straight
3:1:1	103-1948	1	Cap-Reservoir, HYD	24:1	1-603921	1	O-Ring-SAE #6
3:1:2	103-1949	1	Gasket-Cap	24:2	103-1020	1	O-Ring-37 Flare #6
3:2	115-4212	1	Decal-Warning	25	104-7836	1	Filter-Head
4	135-5127	1	Manifold ASM	26	109-4180	1	Element, Oil Filter
5	3241-6	2	Screw-SQH ■	29	116-9129	1	Hydraulic Pump ASM
6	116-6969	1	HYD Cylinder ASM	29:1	115-7855	1	Key-Square
6:1	116-7290	2	Pin-Clevis	29:2	112-0199	1	Seal Kit
6:2	92-1298	2	Pin-Lynch	29:2:1		1	Seal-Anti Extrusion ●
6:3	127-3234	1	Seal Kit	29:2:2		1	Seal-Anti Extrusion ●
6:3:1		1	O-Ring ●	29:2:3		1	Seal-Shaft ●
6:3:2		1	Backup Ring ●	29:2:4		1	Seal-Upper ●
6:3:3		1	Psp Seal ●	29:2:5		1	Seal ●
6:3:4		1	Bs Seal ●	29:2:6		2	O-Ring ●
6:3:5		1	Dust Seal ●	30	3256-24	1	Washer-3/8 SAE
6:3:6		1	O-Ring ●	32	116-6781	4	Spacer
8	1-603990	2	Adapter-Straight	33	116-7307-01	1	Stop-Cylinder
8:1	1-603920	1	O-Ring-SAE #8	35	100-1663	1	Pin
8:2	1-603992	1	O-Ring-37 Flare #8	36	116-6675	1	Hose-Hydraulic, LP
9	321-3	2	Screw-HH 1/4-20 X 5/8	37	116-8151	1	Hose-Hydraulic
10	1-805004	2	Washer-Lock 1/4 Heavy	38	116-9308	1	Hose-Hydraulic
11	3231-25	2	Bolt-Carriage 3/8-16 X 1 1/4	39	116-6677	1	Hose-Hydraulic
12	3231-4	1	Bolt-Carriage 3/8-16 X 1 1/2	40	135-5973	1	Hydraulic Hose ASM
13	3296-59	1	Nut-Nyloc 3/8-16 Thin	42	3-8514	2	Washer-Thrust
16	104-8300	2	Nut-Nyloc 5/16-18 Flg	43	135-3603-03	1	Bracket-Sensor, Control (Depth)
17	3256-2	2	Washer-1/4 Std	44	3229-30	4	Bolt-Carriage 1/4-20 X 1
18	322-5	2	Screw-HH 5/16-18 X 1	45	104-7201	4	Nut-Nyloc 1/4-20 Flg
19	3231-2	4	Bolt-Carriage 3/8-16 X 1	46	119-1065	4	Screw-HWH
20	104-8301	6	Nut-Nyloc 3/8-16 Flg				

● Not serviced separately

■ Use Pro-Lock, Nut Type (P/N 1-840022, .5ml tube) on threads.

Engine Assembly

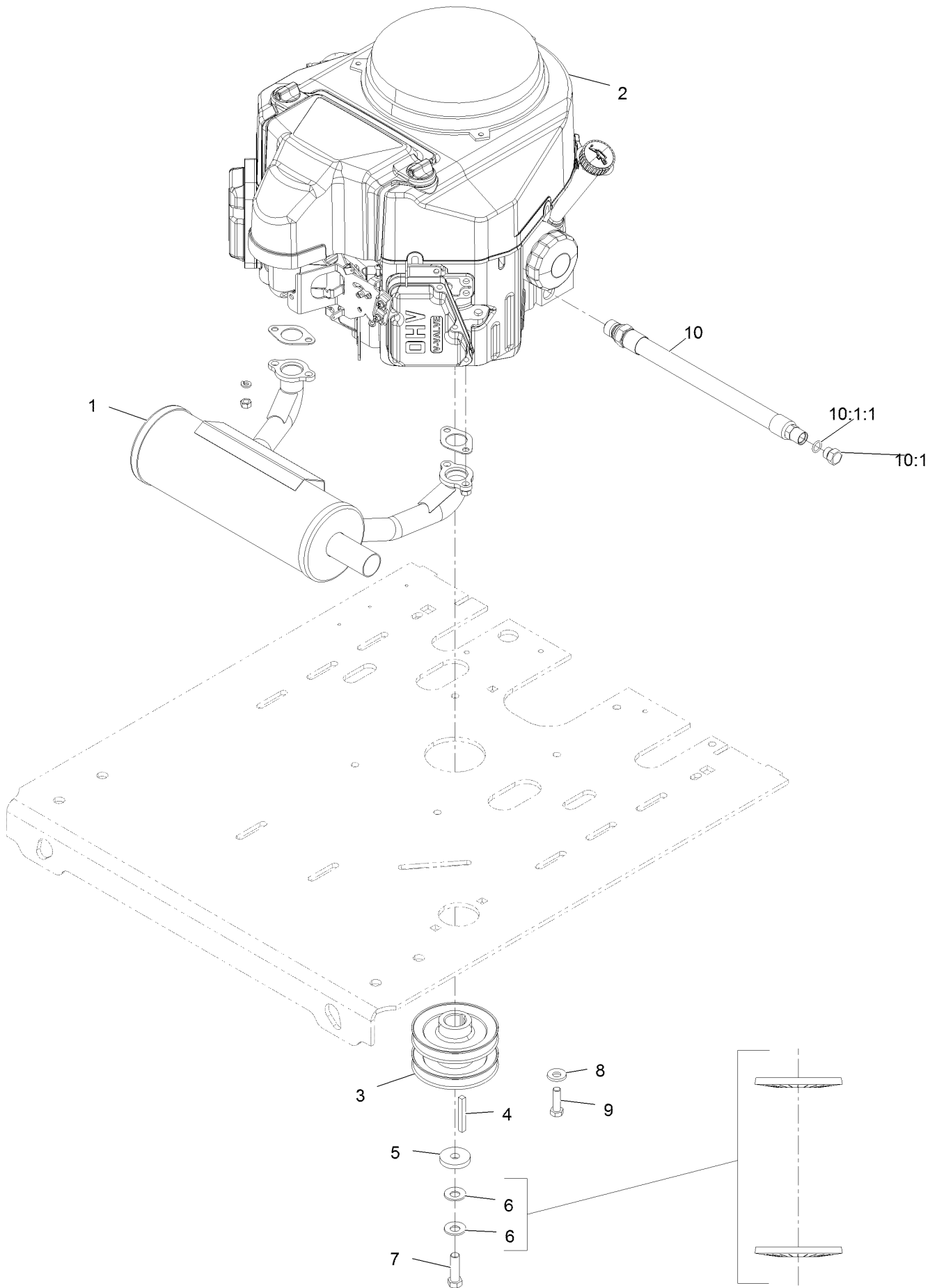

Engine Assembly (continued)

<i>Ref.</i>	<i>Part Number</i>	<i>Qty.</i>	<i>Description</i>	<i>Ref.</i>	<i>Part Number</i>	<i>Qty.</i>	<i>Description</i>
1	116-3735	1	Muffler-Horizontal	8	98-5975	4	Washer-Spring Disc 3/8
2		1	Engine-Kawasaki, Fs541 ■▲	9	323-7	4	Screw-HH 3/8-16 X 1 1/4
3	116-9709	1	Pulley	10	116-4924	1	Asm-Hose Oil Drain W/Plug ◆
4	103-4177	1	Key	10:1	353-508	1	Plug-W/O-Ring ●
5	1-543610	1	Washer	10:1:1	237-42	1	O-Ring
6	1-603610	2	Washer-Spring Disc 7/16				
7	109-9761	1	Screw-HH 7/16-20 X 1 1/2 W/Loctite □				

● Torque to 24-26 ft-lb

▲ Obtain parts from www.kawpowerepc.com

◆ Use a Teflon Pipe Sealant or equivalent on threads.

□ Use Pro-Lock, Nut Type (P/N 1-840022, .5ml tube) on threads.

■ Not serviced separately

Ground Drive Assembly

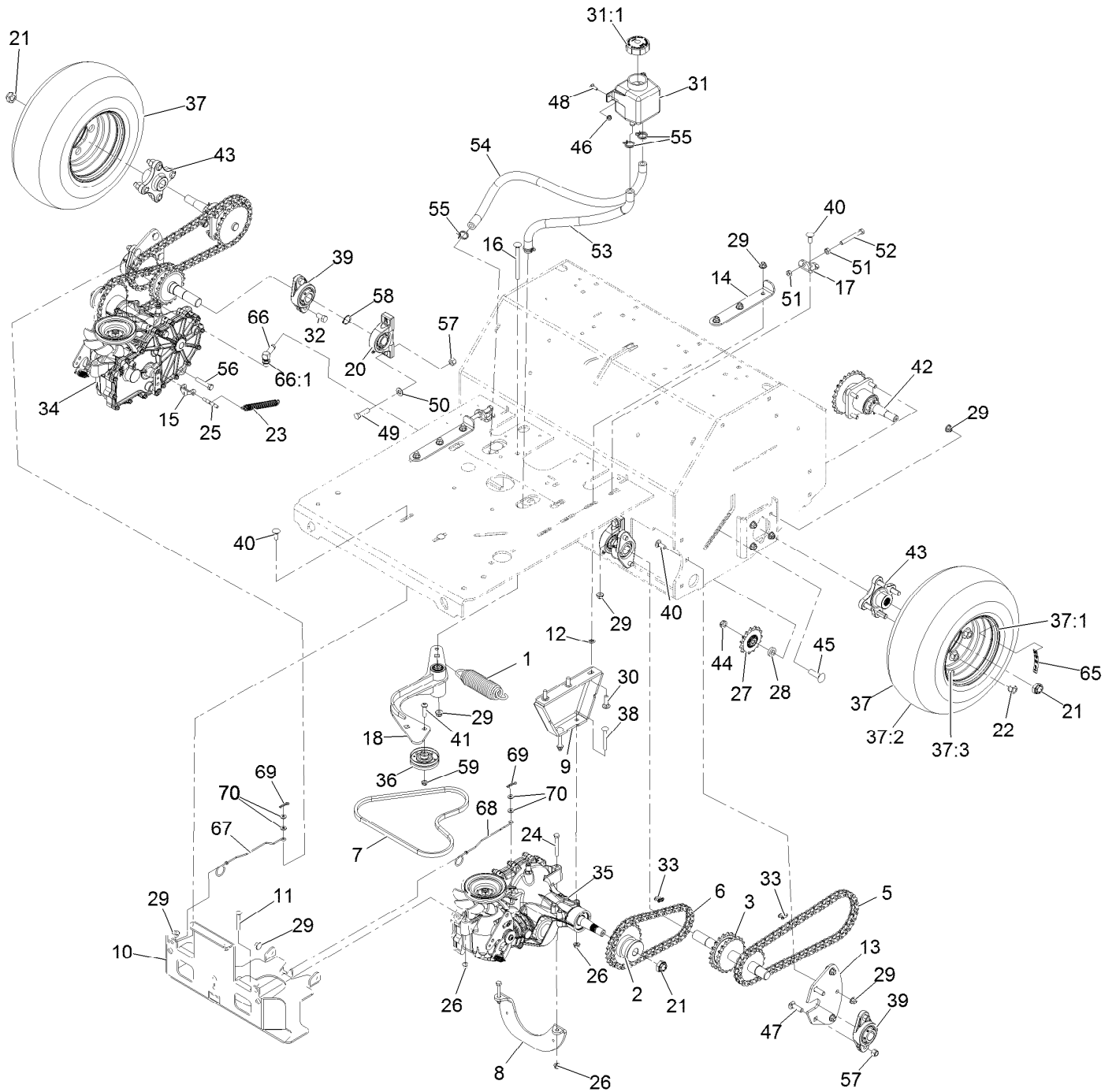

Ground Drive Assembly (continued)

<i>Ref.</i>	<i>Part Number</i>	<i>Qty.</i>	<i>Description</i>	<i>Ref.</i>	<i>Part Number</i>	<i>Qty.</i>	<i>Description</i>
1	116-6317	1	Spring-Extension	37	116-6932	2	Tire ASM (16 X 6.50-8)
2	116-9305	2	Hub-Drive, Chain	37:1	116-6977	1	Rim (8 X 5.375)
3	126-5625	2	Jackshaft	37:2	116-6978	1	Tire
5	126-8808	2	Chain-Roller	37:3	232-27	1	Stem-Valve
6	126-8807	2	Chain-Roller	38	3230-9	4	Bolt-Carriage 5/16-18 X 2 3/4
7	116-8874	1	Belt-4L Section	39	116-6777	4	Bearing-Flange, 2 Bolt
8	135-5051-03	1	Brace-Angle	40	3231-2	10	Bolt-Carriage 3/8-16 X 1
9	116-9710-03	2	Mount-Transmission	41	116-9927	1	Screw-HSBH
10	126-5495-03	1	Guard-Transmission	42	116-9545	2	Axle And Bearing ASM
11	3230-7	2	Bolt-Carriage 5/16-18 X 2 1/4	43	116-3872	2	Hub-Offset
12	107-3154	6	Nut-Push 3/8-16	44	3296-45	2	Nut-Nyloc 1/2-13 Thin
13	116-6596-01	2	Plate-Jackshaft	45	3233-14	2	Screw-CARR
14	116-6619	2	Plate-Adjustment, Transmission	46	104-7201	2	Nut-Nyloc 1/4-20 Flg
15	116-7597	1	Yoke-Brake, Park	47	3232-3	4	Bolt-Carriage 7/16-14 X 1 1/2
16	9000779	1	Bolt-CARR	48	3229-1	2	Bolt-Carriage 1/4-20 X 3/4
17	116-6723	2	Bracket-Hydro, Adjust	49	324-6	4	Screw-HH 7/16-14 X 1 1/2
18	116-9307	1	Idler Arm ASM	50	3256-25	4	Washer-7/16 SAE
20	116-6756	2	Bearing-Pillow Block	51	3217-7	4	Nut-Hex 3/8-16
21	116-2839	4	Nut-Lock	52	99-8664	2	Bolt-HH 3/8-16 X 3 Tap
22	242-50	8	Nut-Lug 1/2-20	53	116-6775	1	Hose-Hydraulic
23	76-4660	1	Spring-Door	54	116-6776	1	Hose-Hydraulic
24	322-12	2	Screw-HH 5/16-18 X 2 1/2	55	109-3322	4	Clamp-Hose
25	116-7596	1	Pin-Brake, Park	56	323-10	2	Screw-HH 3/8-16 X 2
26	104-8300	8	Nut-Nyloc 5/16-18 Flg	57	3296-48	8	Nut-Nyloc 7/16-14
27	126-9108	2	Sprocket-Idler, 15T	58	32151-29	2	Ring-Retaining
28	104-8417	2	Washer	59	3296-59	1	Nut-Nyloc 3/8-16 Thin
29	104-8301	27	Nut-Nyloc 3/8-16 Flg	65	126-2054	2	Decal-Hub, Wheel
30	3231-25	6	Bolt-Carriage 3/8-16 X 1 1/4	66	109-6449	1	Fitting-Elbow, 90
31	109-2250	1	Tank-HYD	66:1	237-42	1	O-Ring
31:1	109-3320	1	Cap-Reservoir, HYD	67	135-0685	1	Rod-Bypass, RH
32	116-7109	4	Screw-HH	68	135-0683	1	Rod-Bypass, LH
33	116-6897	4	Link-Connecting	69	1-806003	2	Hairpin-Cotter
34	135-1050	1	RH Transaxle ASM (W/Pin)	70	119-8952	4	Washer
35	135-1051	1	LH Transaxle ASM (W/Pin)	99	109-9828	1	Bottle-Oil, 32Oz Hydraulic●
36	116-9715	1	Pulley-Idler				

● Not illustrated

Idler Arm Assembly No. 116-9307

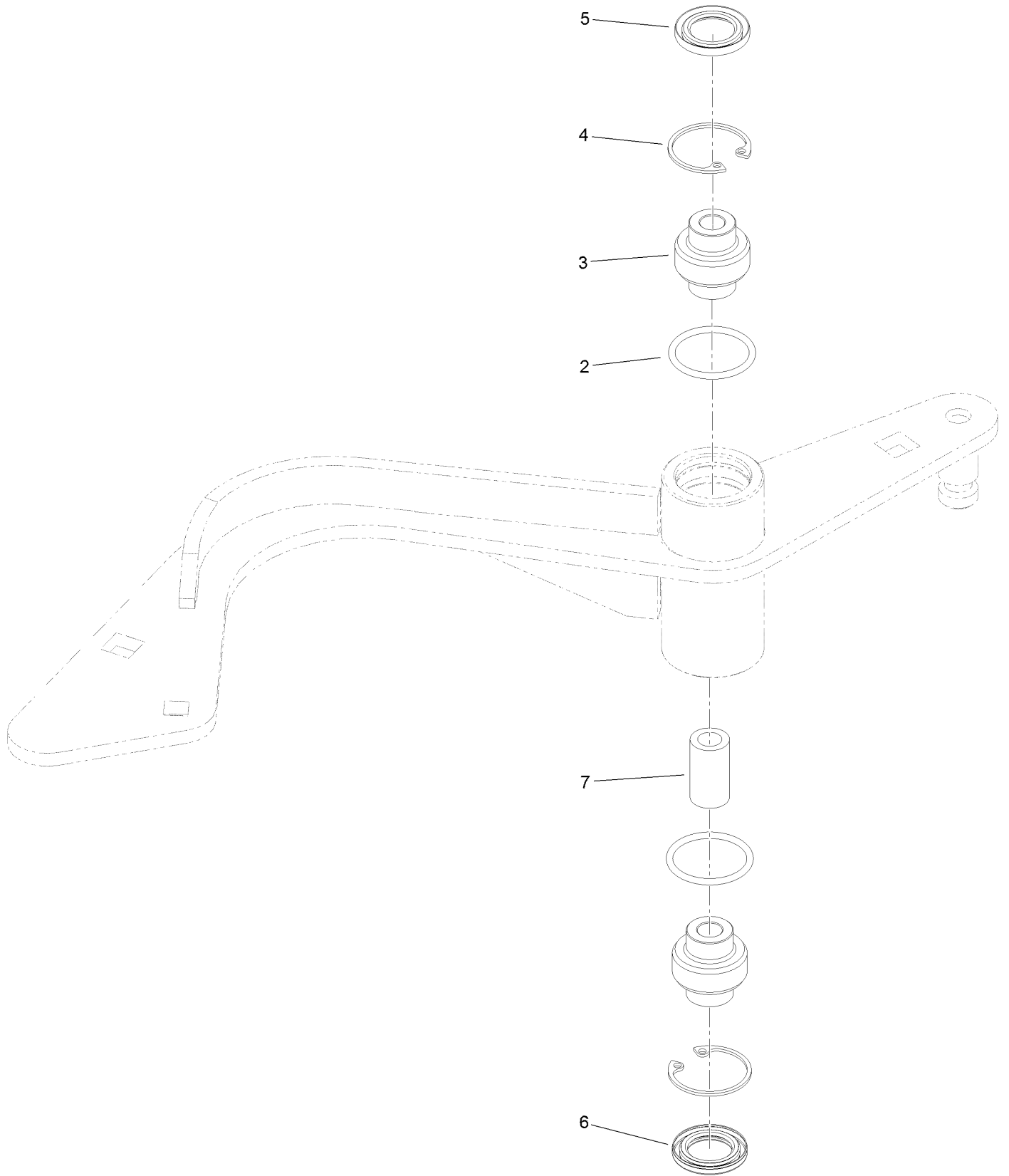

Idler Arm Assembly No. 116-9307 (continued)

<i>Ref.</i>	<i>Part Number</i>	<i>Qty.</i>	<i>Description</i>	<i>Ref.</i>	<i>Part Number</i>	<i>Qty.</i>	<i>Description</i>
2	106-7159	2	O-Ring	5	103-3506	1	Seal-Lip, Single
3	103-3504	2	Bearing-Spherical	6	103-3505	1	Seal-Lip, Double
4	32120-10	2	Ring-Snap	7	1-603401	1	Spacer

LH Transaxle Assembly No. 135-1051

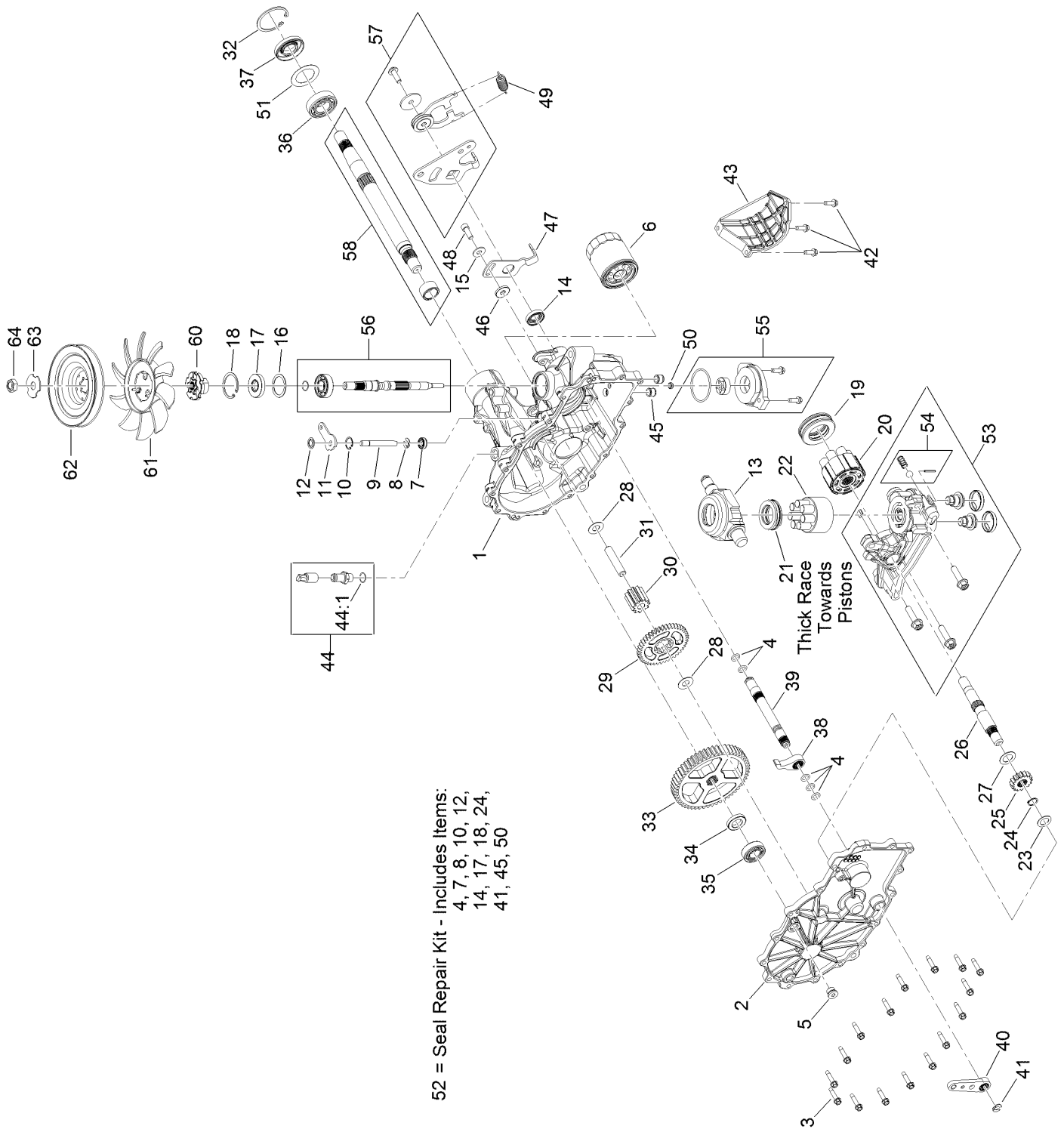

LH Transaxle Assembly No. 135-1051 (continued)

<i>Ref.</i>	<i>Part Number</i>	<i>Qty.</i>	<i>Description</i>	<i>Ref.</i>	<i>Part Number</i>	<i>Qty.</i>	<i>Description</i>
1	114-1676	1	Main Housing Kit	34	120-7975	1	Spacer
2	117-5358	1	RH Housing Side Kit	35	135-1361	1	Bearing-Ball
3	117-5359	16	Screw-HHF	36	120-7976	1	Bearing-Ball
4	114-1678	5	O-Ring	37	104-2144	1	Seal
5	135-1140	1	Plug-Straight	38	114-1697	1	Pawl-Brake
6	109-3321	1	Element-Oil Filter, HYD	39	114-1698	1	Shaft-Brake, Inboard
7	106-8676	1	Seal-Lip	40	125-0021	1	Handle-Brake
8	106-8677	1	Ring-Retaining, External	41	131-0906	1	Ring-Retaining, EXT
9	114-1685	1	Rod-Bypass	42	104-2120	3	Screw
10	106-8679	1	Ring-Retaining, Internal	43	120-7981	1	Guard-Filter, RH
11	106-8680	1	Arm-Bypass	44	109-3278	1	Adapter-Straight
12	106-8681	1	Ring-Retaining, External	44:1	237-42	1	O-Ring
13	104-5304	1	Swashplate-Trunnion	45	126-3251	2	Tube-Charge
14	104-5313	1	Seal-Lip	46	114-8458	1	Spacer
15	114-8491	1	Washer	47	114-8459	1	Arm-Neutral, Right
16	104-5308	1	Spacer	48	106-8682	1	Screw-Sh
17	104-5310	1	Seal-Lip	49	115-8307	1	Spring-Extension
18	104-5309	1	Ring-Retaining	50	131-0908	1	Seal-Gerotor
19	109-2865	1	Bearing-Thrust	51	121-5745	1	Spacer
20	114-1689	1	Motor Cylinder Block Kit	52	109-3537	1	Seal Kit
21	94-6922	1	Bearing-Thrust	53	120-7982	1	RH Center Section Charge Kit
22	110-8561	1	Pump Block ASM	54	114-8464	1	Charge Relief Kit
23	104-5339	1	Washer-Flat	55	114-8465	1	Charge Kit
24	104-5340	1	Ring-Retaining	56	117-5361	1	Input Shaft Kit
25	126-0788	1	Gear-16T	57	126-2291	1	Control Arm Kit
26	114-1691	1	Shaft-Motor	58	114-8470	1	Axle Shaft Kit
27	104-5360	1	Washer	60	116-9705	1	Hub-Pulley
28	94-1933	2	Washer	61	116-9706	1	Fan
29	125-0000	1	Gear-43T	62	116-9707	1	Pulley
30	120-7974	1	Gear-11T	63	116-9708	1	Washer-Slotted
31	104-5329	1	Pin-Jackshaft	64	116-9714	1	Nut-HJ
32	104-2169	1	Ring-Retaining	99	135-3604	1	Brake Shaft Seal Kit ●
33	114-1694	1	Gear-54T				

● Not illustrated

RH Transaxle Assembly No. 135-1050

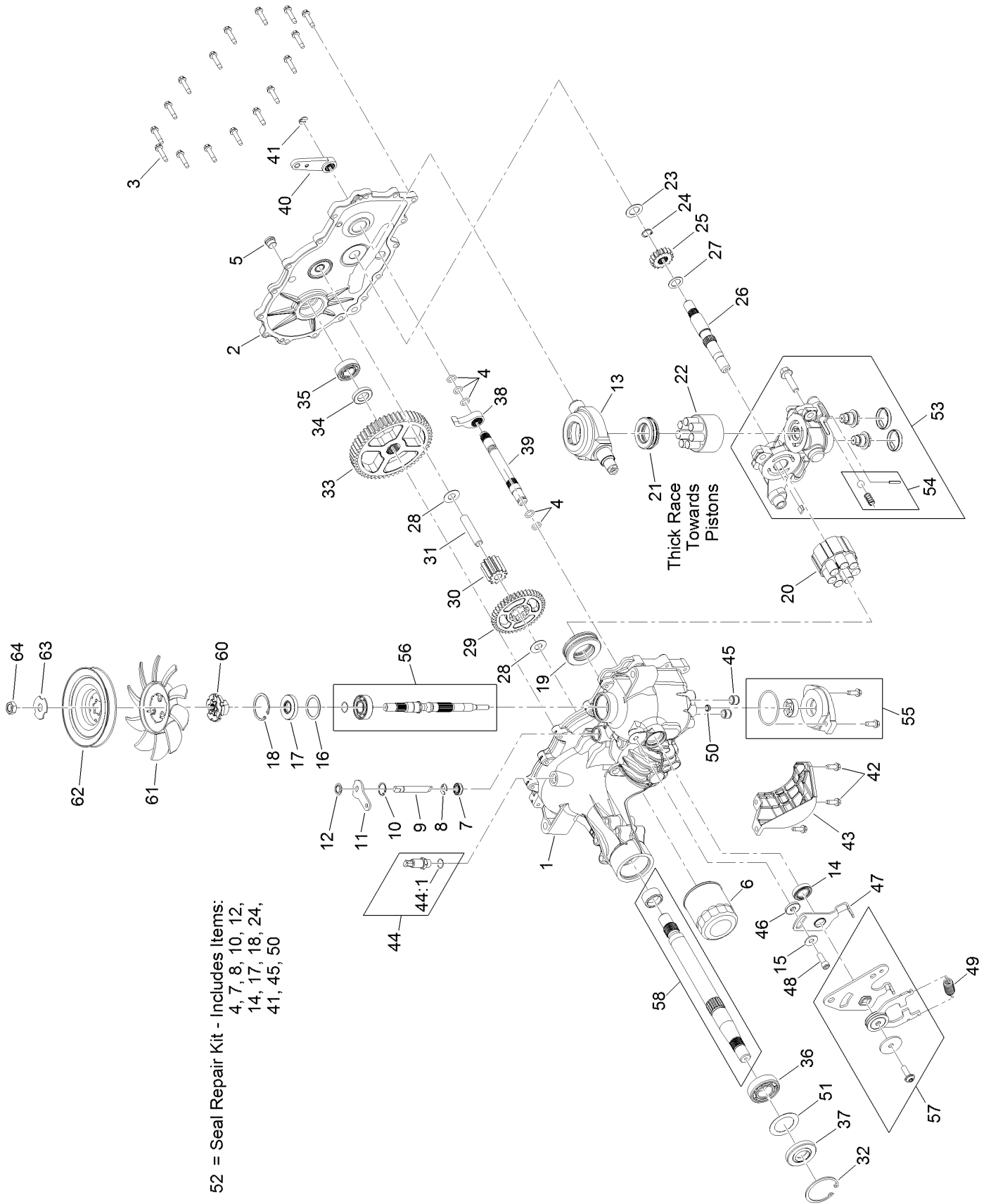

52 = Seal Repair Kit - Includes Items:
 4, 7, 8, 10, 12,
 14, 17, 18, 24,
 41, 45, 50

RH Transaxle Assembly No. 135-1050 (continued)

<i>Ref.</i>	<i>Part Number</i>	<i>Qty.</i>	<i>Description</i>	<i>Ref.</i>	<i>Part Number</i>	<i>Qty.</i>	<i>Description</i>
1	114-1676	1	Main Housing Kit	34	120-7975	1	Spacer
2	117-5358	1	RH Housing Side Kit	35	135-1361	1	Bearing-Ball
3	117-5359	16	Screw-HHF	36	120-7976	1	Bearing-Ball
4	114-1678	5	O-Ring	37	104-2144	1	Seal
5	135-1140	1	Plug-Straight	38	114-1697	1	Pawl-Brake
6	109-3321	1	Element-Oil Filter, HYD	39	114-1698	1	Shaft-Brake, Inboard
7	106-8676	1	Seal-Lip	40	125-0021	1	Handle-Brake
8	106-8677	1	Ring-Retaining, External	41	131-0906	1	Ring-Retaining, EXT
9	114-1685	1	Rod-Bypass	42	104-2120	3	Screw
10	106-8679	1	Ring-Retaining, Internal	43	120-7981	1	Guard-Filter, RH
11	106-8680	1	Arm-Bypass	44	109-3278	1	Adapter-Straight
12	106-8681	1	Ring-Retaining, External	44:1	237-42	1	O-Ring
13	104-5304	1	Swashplate-Trunnion	45	126-3251	2	Tube-Charge
14	104-5313	1	Seal-Lip	46	114-8458	1	Spacer
15	114-8491	1	Washer	47	114-8459	1	Arm-Neutral, Right
16	104-5308	1	Spacer	48	106-8682	1	Screw-Sh
17	104-5310	1	Seal-Lip	49	115-8307	1	Spring-Extension
18	104-5309	1	Ring-Retaining	50	131-0908	1	Seal-Gerotor
19	109-2865	1	Bearing-Thrust	51	121-5745	1	Spacer
20	114-1689	1	Motor Cylinder Block Kit	52	109-3537	1	Seal Kit
21	94-6922	1	Bearing-Thrust	53	120-7982	1	RH Center Section Charge Kit
22	110-8561	1	Pump Block ASM	54	114-8464	1	Charge Relief Kit
23	104-5339	1	Washer-Flat	55	114-8465	1	Charge Kit
24	104-5340	1	Ring-Retaining	56	117-5361	1	Input Shaft Kit
25	126-0788	1	Gear-16T	57	126-2291	1	Control Arm Kit
26	114-1691	1	Shaft-Motor	58	114-8470	1	Axle Shaft Kit
27	104-5360	1	Washer	60	116-9705	1	Hub-Pulley
28	94-1933	2	Washer	61	116-9706	1	Fan
29	125-0000	1	Gear-43T	62	116-9707	1	Pulley
30	120-7974	1	Gear-11T	63	116-9708	1	Washer-Slotted
31	104-5329	1	Pin-Jackshaft	64	116-9714	1	Nut-HJ
32	104-2169	1	Ring-Retaining	99	135-3604	1	Brake Shaft Seal Kit ●
33	114-1694	1	Gear-54T				

● Not illustrated

Axle and Bearing Assembly No. 116-9545

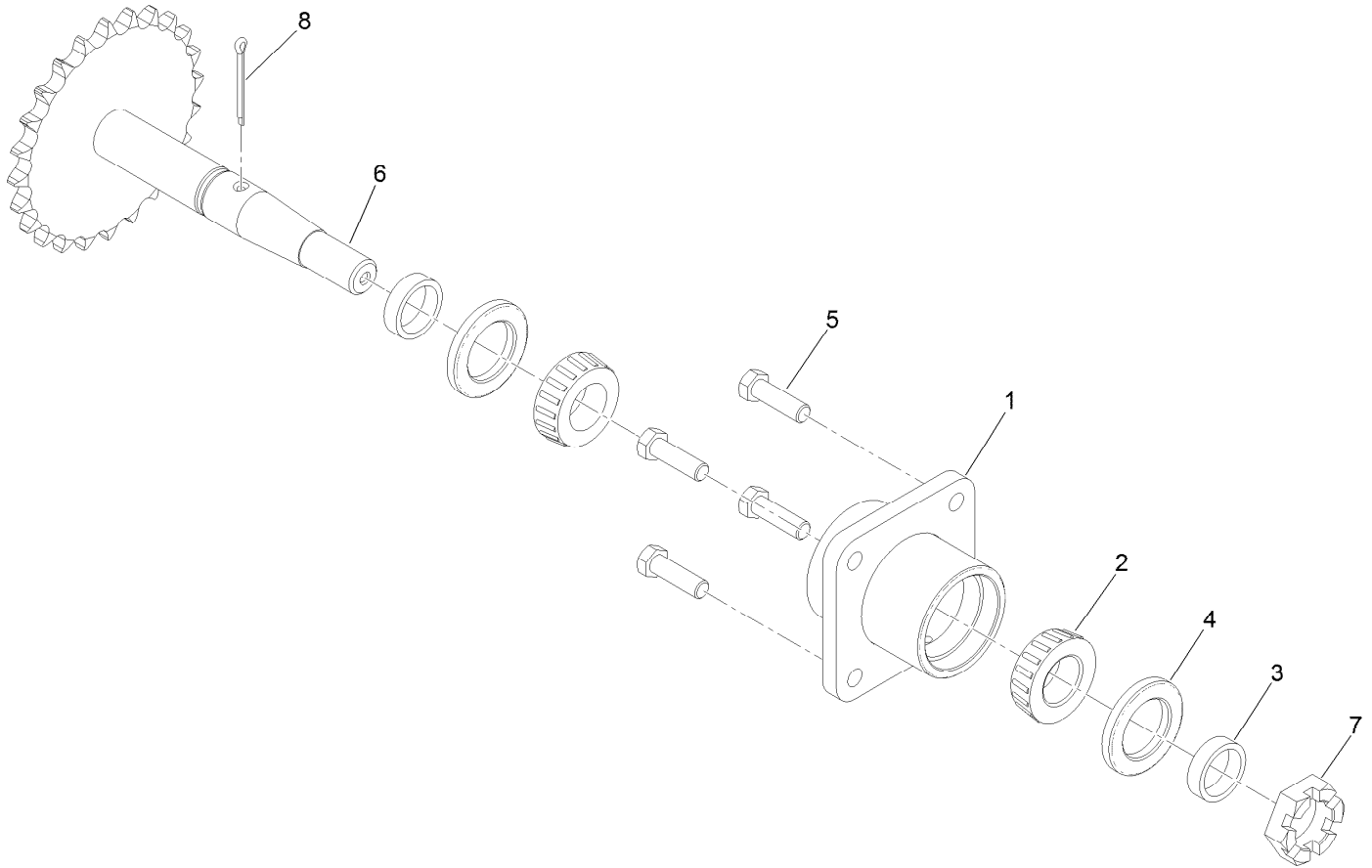

Axle and Bearing Assembly No. 116-9545 (continued)

<i>Ref.</i>	<i>Part Number</i>	<i>Qty.</i>	<i>Description</i>	<i>Ref.</i>	<i>Part Number</i>	<i>Qty.</i>	<i>Description</i>
1	116-6746-01	1	Mount-Bearing, Wheel	5	323-7	4	Screw-HH
2	1-543509	2	Bearing-Roller, Tapered	6	126-0459	1	Axle
3	116-6758	2	Spacer	7	99-3139	1	Nut
4	1-543511	2	Seal-Grease	8	1-806800	1	Pin-Cotter

Tine Assembly

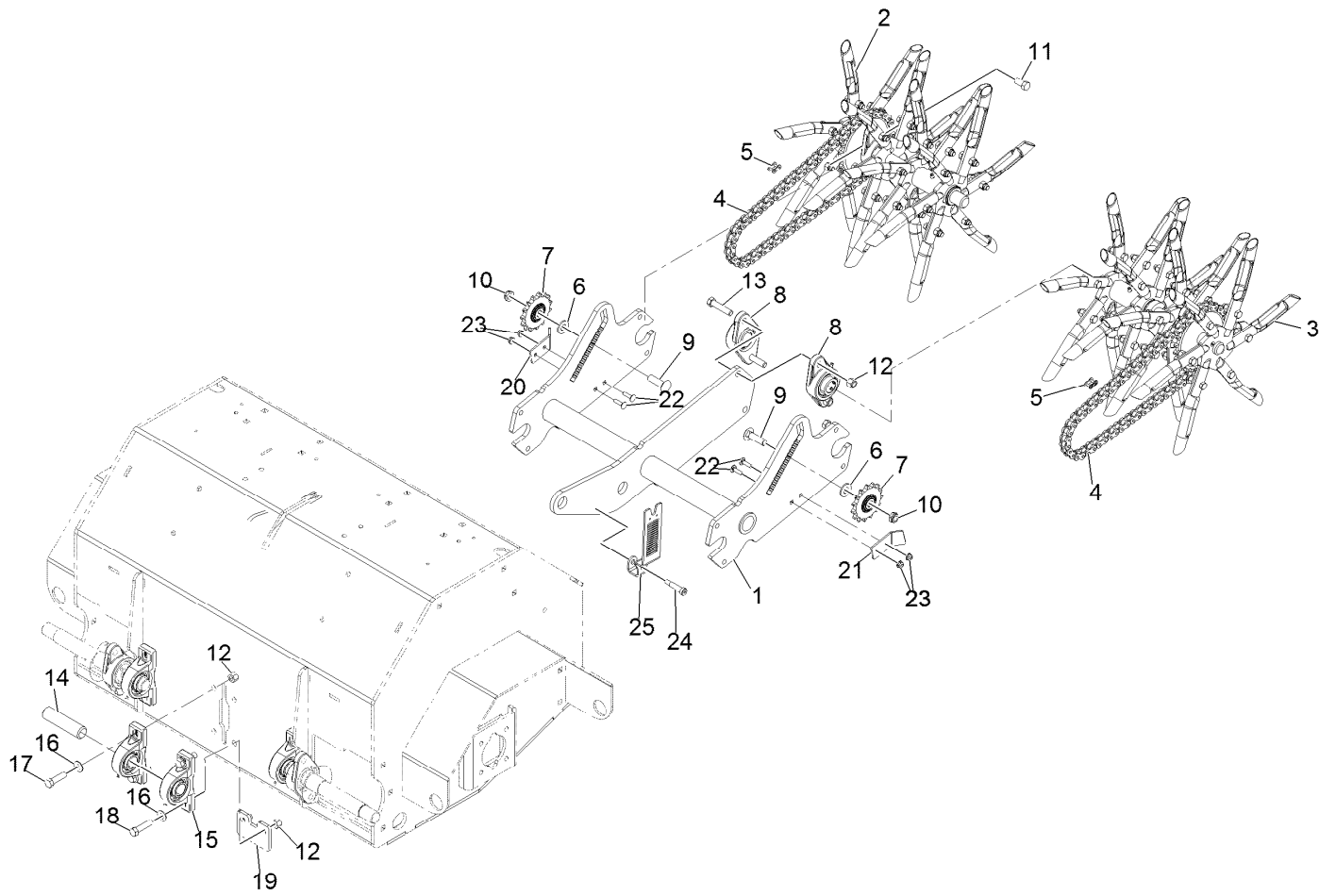

Tine Assembly (continued)

<i>Ref.</i>	<i>Part Number</i>	<i>Qty.</i>	<i>Description</i>	<i>Ref.</i>	<i>Part Number</i>	<i>Qty.</i>	<i>Description</i>
1	135-5952-03	1	Arm-Trail	14	116-6629	1	Shaft
2	135-2507	1	RH Tine Wheel ASM	15	116-6756	2	Bearing-Pillow Block ●
3	135-2510	1	LH Tine Wheel ASM	16	3256-25	4	Washer-7/16 SAE
4	126-8808	2	Chain-Roller	17	324-6	2	Screw-HH 7/16-14 X 1 1/2
5	116-6897	2	Link-Connecting	18	324-7	2	Screw-HH
6	87-7270	2	Washer-Thrust	19	116-7327-01	1	Plate-Downstop
7	126-9108	2	Sprocket-Idler, 15T	20	126-4192-03	1	Guard-Chain, RH
8	116-6777	2	Bearing-Flange, 2 Bolt	21	126-4193-03	1	Guard-Chain, LH
9	3233-14	2	Screw-CARR	22	3229-30	4	Bolt-Carriage 1/4-20 X 1
10	3296-45	2	Nut-Nyloc 1/2-13 Thin	23	104-7201	4	Nut-Nyloc 1/4-20 Flg
11	116-7109	4	Screw-HH ●	24	114-0239	1	Screw-HSH
12	3296-48	6	Nut-Nyloc 7/16-14	25	135-5109	1	Bracket-Control, Depth
13	324-8	2	Screw-HH				

● Use Pro-Lock, Nut Type (P/N 1-840022, .5ml tube) on threads.

LH Tine Wheel Assembly No. 135-2510

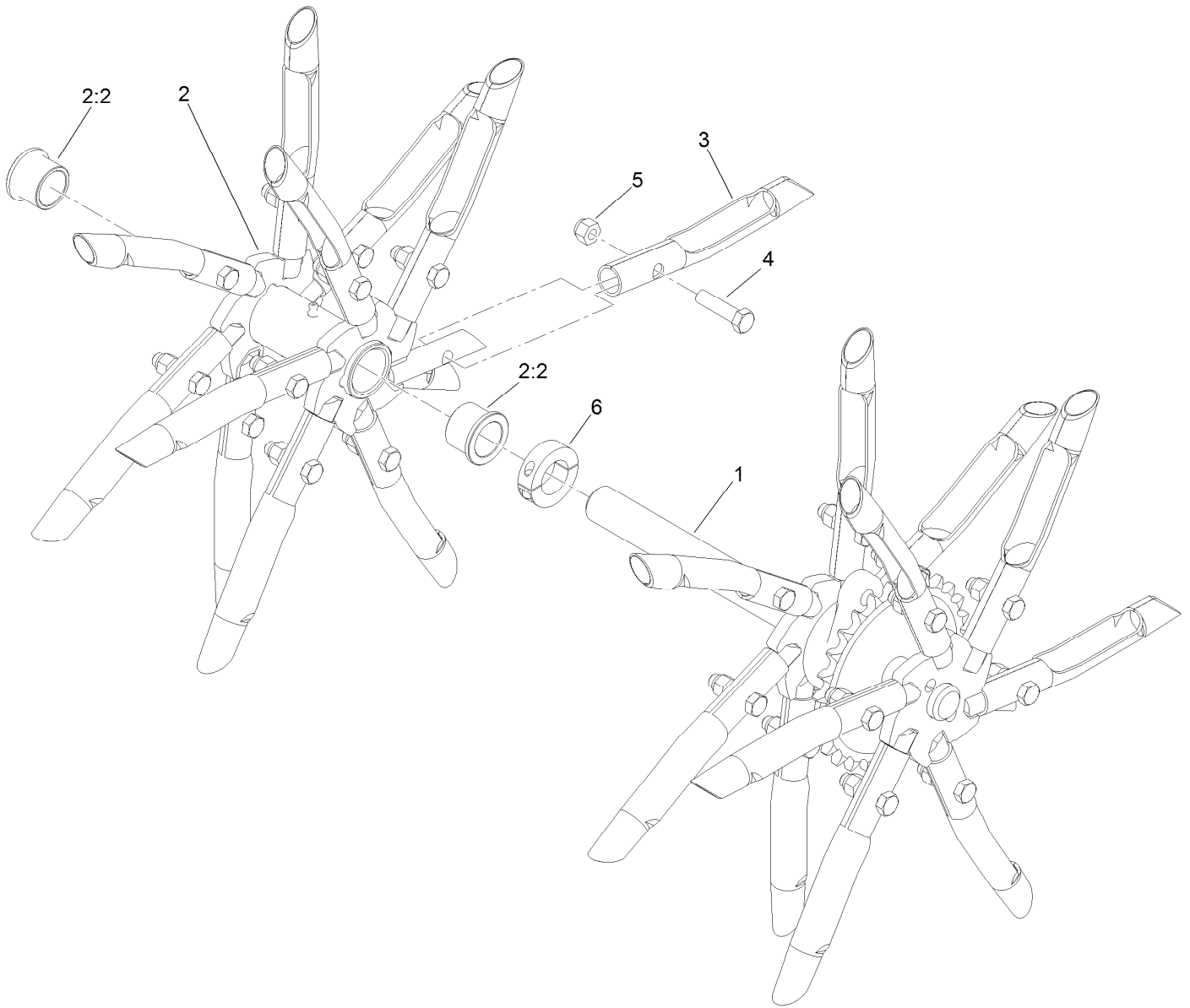

LH Tine Wheel Assembly No. 135-2510 (continued)

<i>Ref.</i>	<i>Part Number</i>	<i>Qty.</i>	<i>Description</i>
1	135-4343	1	Shaft-Tine, LH
2	135-4342	1	Tine Shaft Float ASM
2:2	94-8949	2	Bushing-Flange
3	126-2143	24	Tine-Coring (3/4 Inch)

<i>Ref.</i>	<i>Part Number</i>	<i>Qty.</i>	<i>Description</i>
4	323-8	24	Screw-HH
5	3296-39	24	Nut-Lock, NI
6	116-7271	1	Collar-Locking ●

● Use Loctite® 243 on threads.

RH Tine Wheel Assembly No. 135-2507

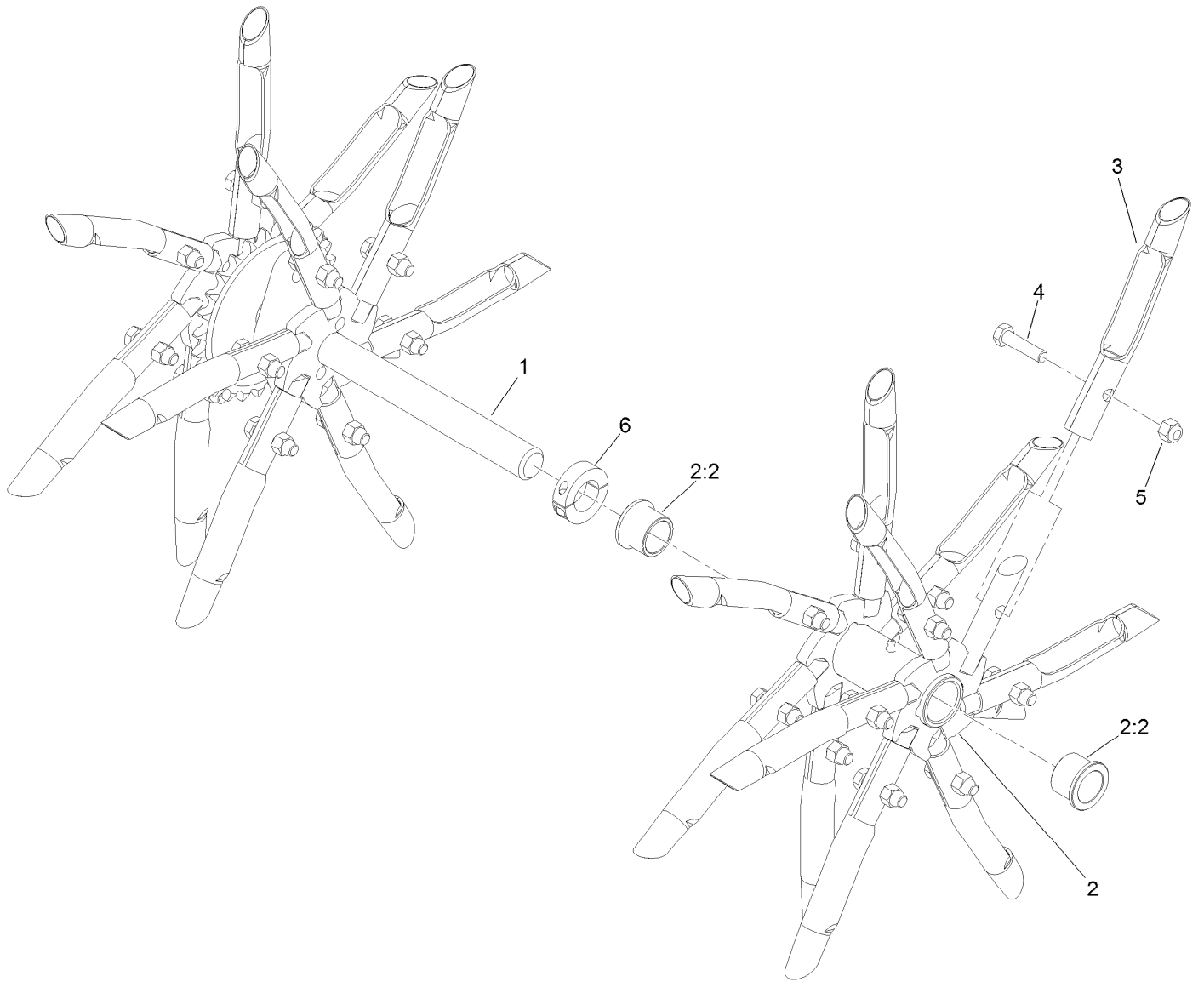

RH Tine Wheel Assembly No. 135-2507 (continued)

<i>Ref.</i>	<i>Part Number</i>	<i>Qty.</i>	<i>Description</i>	<i>Ref.</i>	<i>Part Number</i>	<i>Qty.</i>	<i>Description</i>
1	135-4341	1	Shaft-Tine, RH	4	323-8	24	Screw-HH
2	135-4342	1	Tine Shaft Float ASM	5	3296-39	24	Nut-Lock, NI
2:2	94-8949	2	Bushing-Flange	6	116-7271	1	Collar-Locking
3	126-2143	24	Tine-Coring (3/4 Inch)				

Electrical Assembly

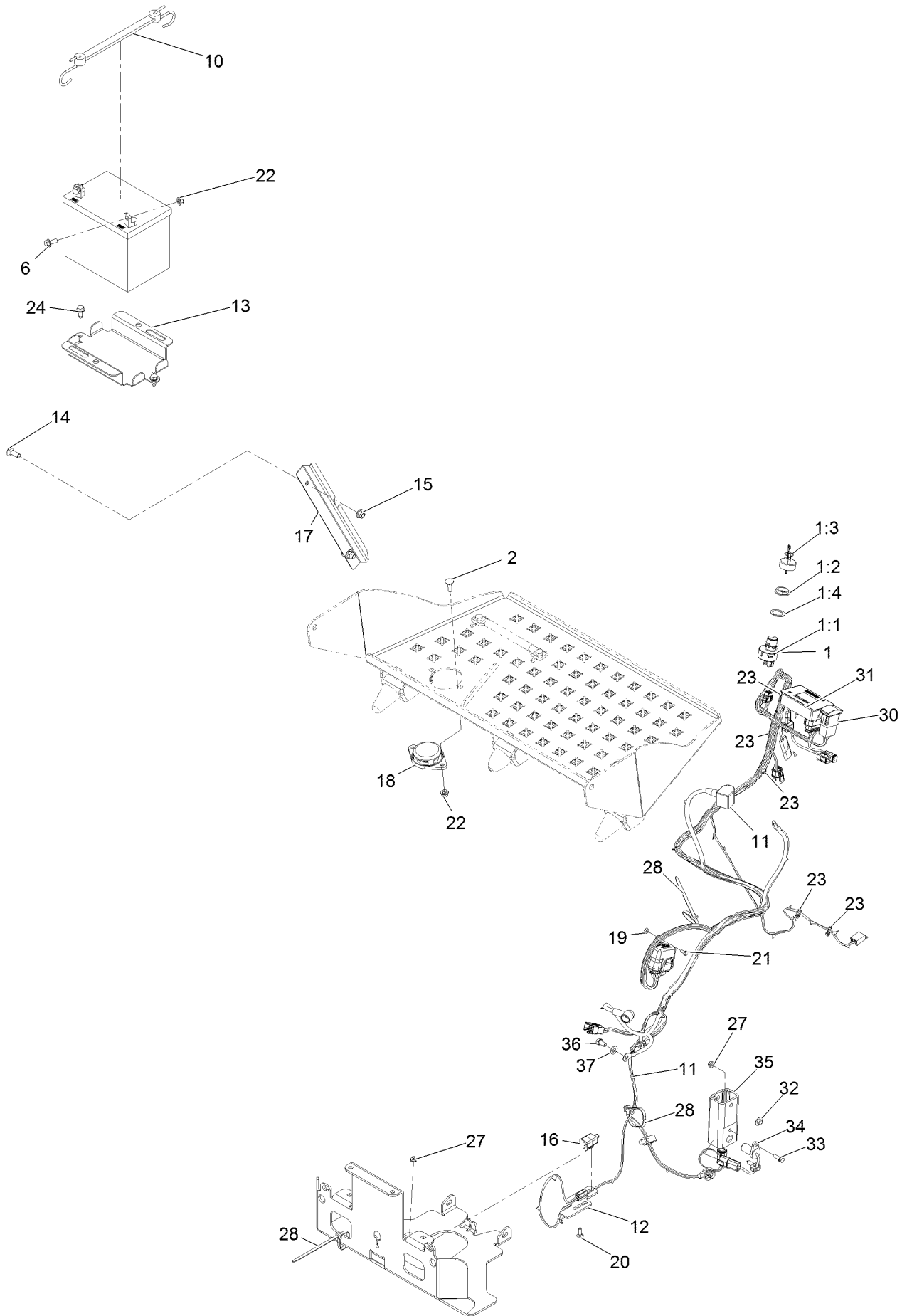

Electrical Assembly (continued)

<i>Ref.</i>	<i>Part Number</i>	<i>Qty.</i>	<i>Description</i>	<i>Ref.</i>	<i>Part Number</i>	<i>Qty.</i>	<i>Description</i>
1	126-6285	1	Ignition Switch ASM	20	3229-1	1	Bolt-Carriage 1/4-20 X 3/4
1:1		1	Switch-Ignition ●	21	3290-321	2	Screw-HWH
1:2	108-8660	1	Nut-Mounting	22	104-8300	4	Nut-Nyloc 5/16-18 Flg
1:3	106-5270	1	Ignition Key Set	23	1-303287	5	Tie-Cable 5 1/2 (Small)
1:4	108-8659	1	Washer-Backup	24	32144-70	2	Screw-HWH 5/16-18 X 3/4 Tf
2	3230-2	2	Bolt-Carriage 5/16-18 X 1	27	104-7201	2	Nut-Nyloc 1/4-20 Flg
6	3234-5	2	Screw-HH Flg 5/16-18 X 3/4	28	1-303335	5	Tie-Cable 7 15/16 (Large)
10	104-2466	1	Holddown-Battery	30	100-1535	1	Switch
11	135-5919	1	Harness-Wire ■	31	135-6910	1	Hour Meter ASM
12	116-7589	1	Mount-Switch	32	3290-320	1	Nut-Push
13	116-9383-03	1	Bracket-Battery	33	32105-15	1	Screw-Machine 1/4-20 X 3/4
14	3231-2	2	Bolt-Carriage 3/8-16 X 1	34	135-4381	1	Sensor, Quadrature
15	104-8301	2	Nut-Nyloc 3/8-16 Flg	35	135-6609	1	Housing-Depth Control 30
16	110-6765	1	Switch	36	33114-016	1	Screw-HH M8-1.25 X 16Mm
17	116-9394-03	1	Guard-Harness	37	33094-00	1	Washer
18	92-6282	1	Switch-Seat				
19	3296-2	2	Nut-Nyloc #10-24				

● Not serviced separately

■ Use dielectric grease on all unsealed connectors and terminals only. Do not apply in sealed connectors.

Notes:

Notes:

Notes:



MAXIMIZE THE PERFORMANCE OF YOUR EXMARK MACHINE.



EXMARK® PREMIUM ENGINE OIL

Exmark now offers a family of engine oil viscosities to perform well in any environment. Each viscosity has the same synthetic formulation to give you what you need in punishing conditions. We designed each grade to the highest quality, making it ideal even for diesel applications. Coupled with Exmark Premium Fuel Treatment, we have the performance products to make your machine hum.

EXMARK PREMIUM ENGINE OIL SAE 30/10W-30

- Meets zero shear requirements of a straight grade SAE 30 as well as the cold temp properties of a 10W-30.
- Most versatile oil in the industry.
- Superior corrosion protection over conventional oil - even in corrosive, humid environments.

EXMARK PREMIUM ENGINE OIL SAE 20W-50

- Perfect for your big block engine, or any application in severe service.
- Same full synthetic formulation as all other Exmark Premium viscosities.
- Also effective for use in severe service small block engines.

EXMARK PREMIUM ENGINE OIL SAE 10W-50

- Full synthetic formulation gives you peak performance. Don't settle for less.
- Wide span multi-grade combines easy starting in cold weather with maximum protection in high temperature operation.
- Reduce friction & wear over standard mineral formulations.

EXMARK PREMIUM ENGINE OIL SAE 0W-40

- The perfect choice for when the weather turns cold or unpredictable, and your Exmark UTV has to perform.
- Commercial quality for severe service.
- Advanced additive package helps prevent corrosion from long-term storage.

EXMARK PREMIUM ENGINE OIL UTV FORMULATION

- 4-cycle high-temp formulation.
- Heavier viscosity, full synthetic, perfect for your UTV.

EXMARK PREMIUM UTV EXTREME CONDITIONS GEAR OIL

- SAE 80W-90, designed to keep your UTV performing at its peak.
- Shear stable, hypoid gear lube.
- Includes a premium additive system to combat wear, oxidation, rust & corrosion.

Available from your local Exmark dealer. Find your closest dealer at exmark.com

EXMARK ACCESSORIES AND OPTIONS*

MID-MOUNT RIDING ACCESSORIES AND OPTIONS

CUSTOM RIDE SEAT SUSPENSION SYSTEM	OPERATOR CONTROLLED DISCHARGE
FULL SUSPENSION SEAT	SUN SHADE
DECK LIFT ASSIST KIT	TRASH CONTAINER
HITCH KIT	TURF STRIPER
LIGHT KIT	ULTRA VAC COLLECTION SYSTEM
12V POWER PORT	ULTRA VAC QUICK DISPOSAL SYSTEM
MICRO-MULCH SYSTEM	

OUT-FRONT RIDING ACCESSORIES AND OPTIONS

CUSTOM RIDE SEAT SUSPENSION SYSTEM	SNOW BLADE
DUAL-TAIL WHEEL	SNOWBLOWER
FLOOR PAN EXTENDER	SUN SHADE
HITCH KIT	TRASH CONTAINER
LIGHT KIT	ULTRA VAC COLLECTION SYSTEM
MICRO-MULCH SYSTEM	ULTRA VAC QUICK DISPOSAL SYSTEM
ROLL OVER PROTECTION SYSTEM (ROPS)	WEATHER CAB

WALK-BEHIND ACCESSORIES AND OPTIONS

GRASS CATCHER	TURF STRIPER
MICRO-MULCH SYSTEM	STANDON

*Some accessories and options not available for some models.

Place Model No. and Serial No.
Label Here (Included in the Literature
Pack) or Fill in Below

Model No. _____

Serial No. _____

Date Purchased _____

Engine Model No. and Spec. No. _____

Engine Serial No. (E/No) _____

© 2018 Exmark Mfg. Co., Inc.
2101 Ashland Ave
Beatrice, NE 68310
All Rights Reserved

Part No. 4504-203 Rev. A
(402) 223-6375
Fax (402) 223-5489
Printed in the USA.

