



# **TURF TRACER<sup>®</sup>**

## **S-SERIES**

Model No. TTS541GKA52300—Serial No. 404314159 and Up

Picture below may not reflect actual product.

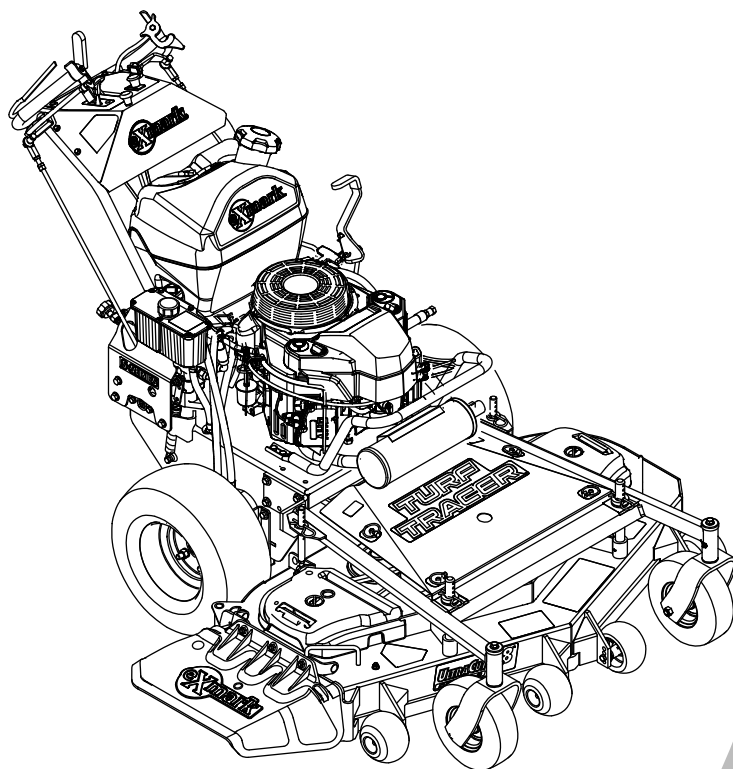

# **Parts Manual**

Part No. 4503-976 Rev. A

# Ordering Replacement Parts

To order replacement parts, please supply the part number, the quantity, and the description of each part desired.

## Understanding Reference Numbers

Each identified part in an illustration has a reference number. The reference number for a part also appears in the parts list, along with other information about the part.

This catalog uses two special reference number formats, one to indicate parts in a service assembly and another to indicate the quantity of a given part in an illustration.

## Service Assembly Reference Numbers

Parts in service assemblies have reference numbers in the form a:b. The a represents the reference number of the entire service assembly and the b represents a sequential number unique to each part within the service assembly.

For example, a wheel assembly might be identified by reference number 6, the tire by 6:1, the valve by 6:2, and the wheel by 6:3. When you order the assembly identified by reference number 6, you receive all parts identified by reference numbers 6:1, 6:2, and 6:3. However, you may also order any part individually. Reference numbers of this type appear in illustration and in parts lists.

## Reference Numbers Indicating Quantity

In an illustration, if a reference number indicates more than one part, the reference number has the form nX y. The n represents the quantity of the part, the X is the multiplication symbol, and the y represents the reference number.

For example, in an illustration, the reference number 2X 37 means that two of the parts identified by reference number 37 are indicated.

# Touch Up Paint

Exmark black touch up spray paint – gloss black.

Exmark red touch up paint (spray paint – P/N 1-850337 - .6 oz liquid bottle – P/N 103-9140).



If your Exmark dealer does not have the Exmark part in stock, Exmark will get the parts to the dealer the next business day or the part will be FREE Guaranteed!! (Some restrictions apply. See your participating Exmark Dealer for details.)

## Contents

Complete Deck Assembly.....	4
Deck Assembly.....	6
Deck W/Decals Assembly.....	8
Deck Idler Assembly No. 126-2314.....	10
Main Frame Assembly.....	12
Engine Deck.....	14
Handle Assembly.....	16
Controls Assembly.....	18
Fuel Assembly.....	20
Engine Assembly.....	22
Ground Drive Assembly.....	24
Pump Idler Assembly No. 126-0615.....	26
Electrical Assembly.....	28

# Complete Deck Assembly

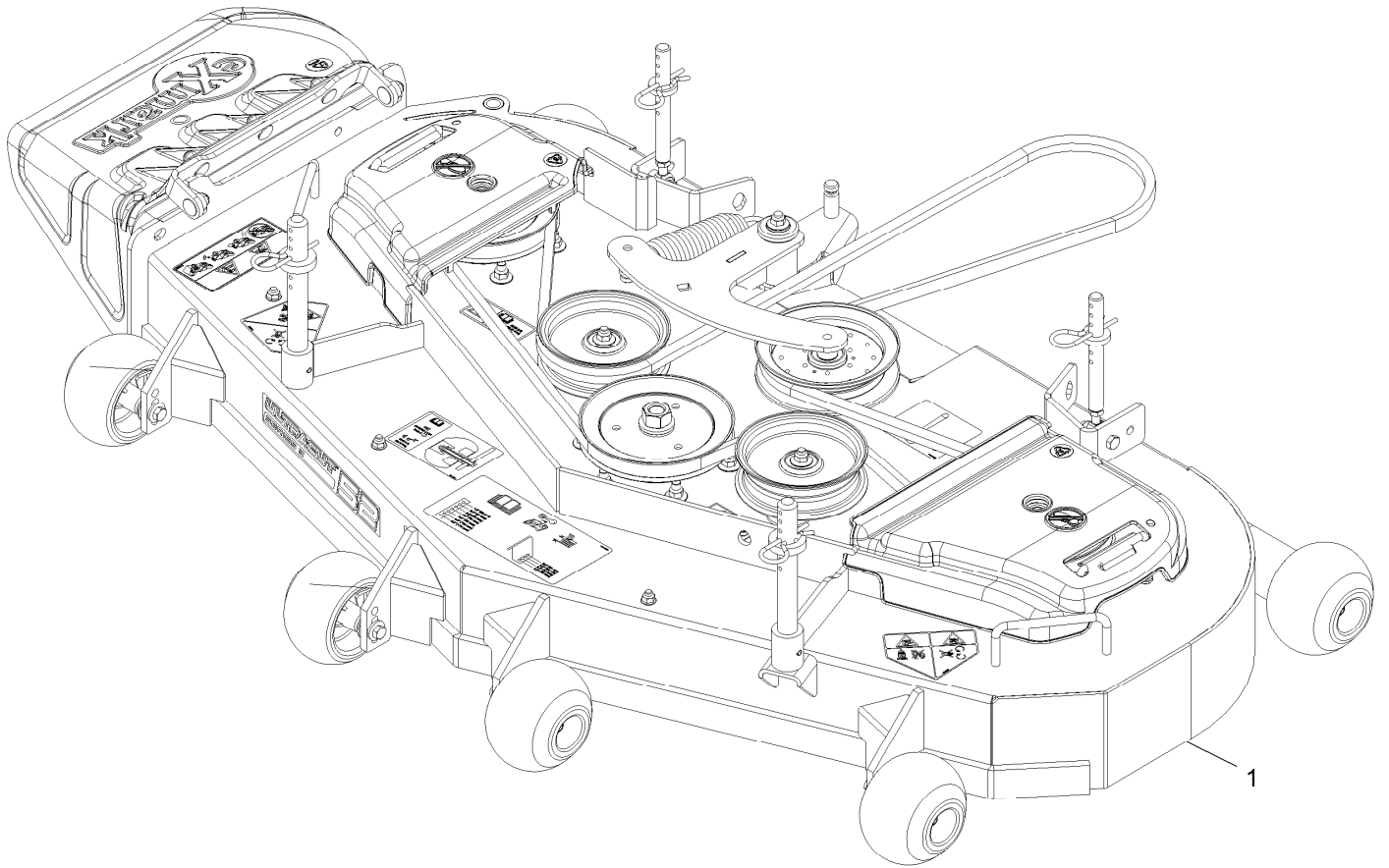

# Complete Deck Assembly (continued)

<i>Ref.</i>	<i>Part Number</i>	<i>Qty.</i>	<i>Description</i>
1	126-1910	1	ASM-Complete Deck 52

# Deck Assembly

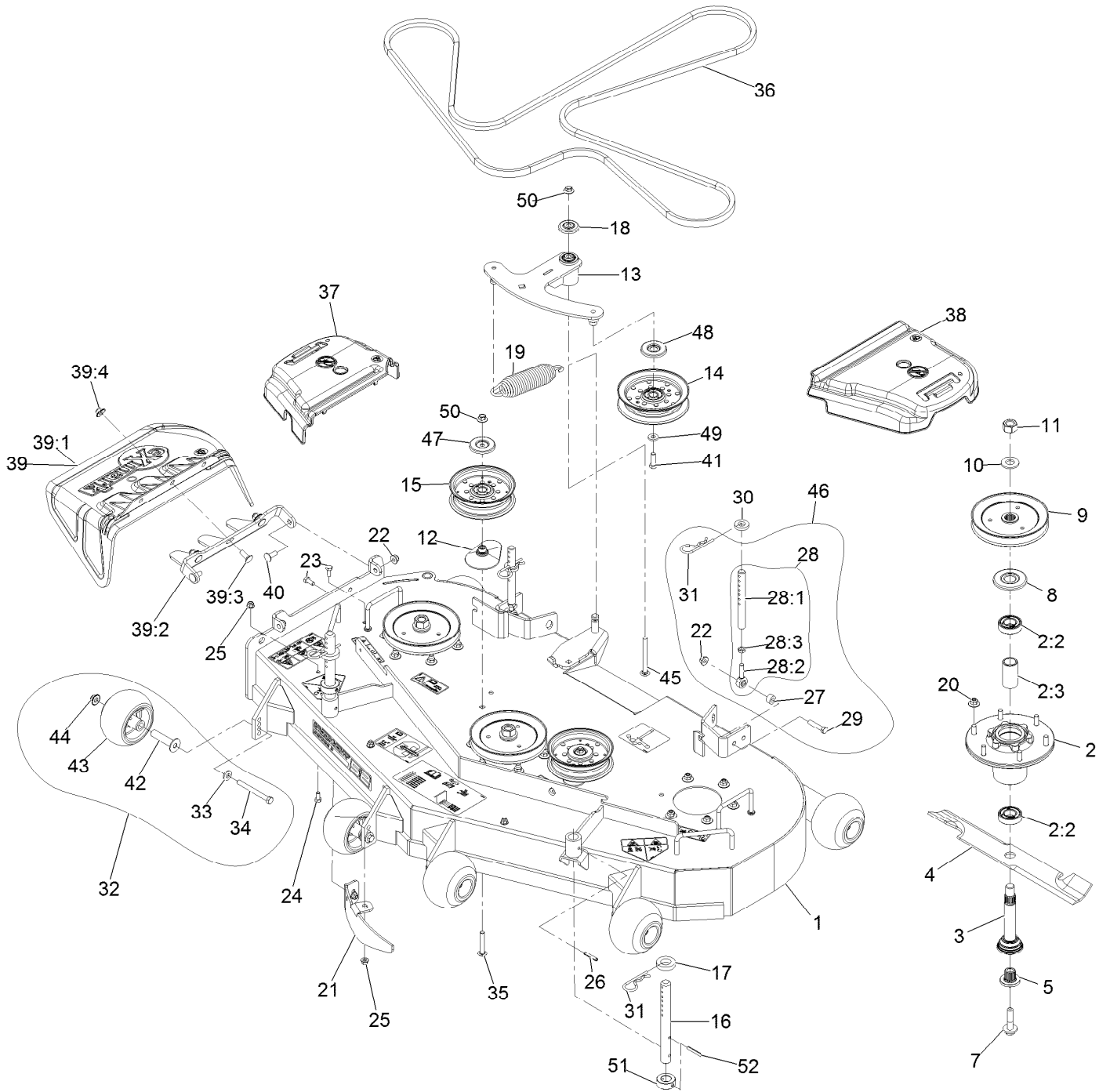

## Deck Assembly (continued)

Ref.	Part Number	Qty.	Description	Ref.	Part Number	Qty.	Description
1	126-0766	1	ASM, Deck W/ Decals, 52"	27	1-603050	2	Spacer
2	116-3344	3	ASM-Cutter Hsg With Bearings	28	1-414521	2	Link Assy
2:2	116-0720	2	Bearing-Ball	28:1	1-413525	1	Link, Rear Deck Support
2:3	116-3312	1	Spacer-Bearing	28:2	1-613204	1	Balljoint
3	116-3342	3	ASM-Spindle And Seal □	28:3	3220-3	1	Nut-HJ
4	103-6382	3	Blade, Solid ●	29	323-9	2	Screw-HH
4	103-6387	3	Blade, Low Lift ●	30	1-323539	2	Spacer
4	103-6392	3	Blade, Mulching ◆	31	1-806009	4	Hairpin, .177
4	103-6402	3	Blade-Notched	32	116-9981	6	Kit, Anti-Scalp Roller
4	116-5175	3	Blade-Extreme 2, 18.00" ●	33	98-5975	6	Washer-Belleville
5	103-3037	3	Bushing, Splined	34	116-9362	6	Screw-HH
7	109-9220	3	Screw,Sems (1/2-20 X 2.19, GR5) ■ ○	35	3231-40	2	Bolt-CARR, Short Neck
8	116-1286	3	Guard,Bearing Top .989	36	126-0784	1	Belt, Deck
9	116-0675	3	Sheave,Blade Drive 6.50	37	109-6935	1	Cover-Belt, RH
10	103-2802	3	Washer	38	109-6936	1	Cover-Belt, LH
11	116-7306	3	Nut-Hex ▲	39	126-0959	1	ASM, Discharge Chute
12	109-2872	2	Spacer-Pulley	39:1	109-2738	1	Chute, Discharge
13	126-2314	1	ASM, Deck Idler	39:2	126-0958-01	1	Bracket, Discharge Chute
14	126-9196	1	Idler-Pulley, Flat	39:3	3231-22	3	Screw-CARR
15	126-9197	2	Idler-Pulley, Flat 5.00X1.31	39:4	109-6658	3	Nut-Flange, NI
16	135-7043	2	Rod, Deck Support Tts	40	3231-22	2	Screw-CARR
17	1-413425	2	Spacer-Deck Support	41	323-7	1	Screw-HH
18	103-2916	1	Guard-Top	42	116-8131	6	Axle, Roller
19	116-6317	1	Spring-Extension	43	103-8415	6	Roller-Anti-Scalp
20	109-6658	18	Nut-Flange, NI	44	109-6658	6	Nut-Flange, NI
21	126-2783-01	1	Baffle, Dogleg	45	3231-24	1	Screw-CARR
22	104-8301	4	Nut-HF, NI	46	1-411532	2	Kit, Support Link W/Pin
23	322-3	2	Screw-HH	47	126-8043	2	Shield-Dust
24	322-2	3	Screw-HH	48	126-9195	1	Shield-Guard, Dust
25	104-8300	5	Nut-HF, NI	49	43-0940	1	Spacer
26	1-806332	2	Roll Pin, 1/4 X 1-1/2	50	32128-19	3	Nut-HF
				51	135-4828	2	Collar, Deck Height Pin
				52	32121-32	2	Pin-Roll

● Optional Equipment

▲ Torque to 130-160 ft-lb

◆ Requires installation of mulch kit for proper mulching. See your Exmark dealer for details.

□ Apply Mobil HTS grease (P/N 103-5217 1.5 oz packet) (or a food-grade anti-seize). See operator s manual for locations.

○ Apply lubricant to threads as needed to prevent seizing. Copper based anti-seize preferable. Grease is an acceptable substitute.

■ Torque to 50-60 ft-lb

# Deck W/Decals Assembly

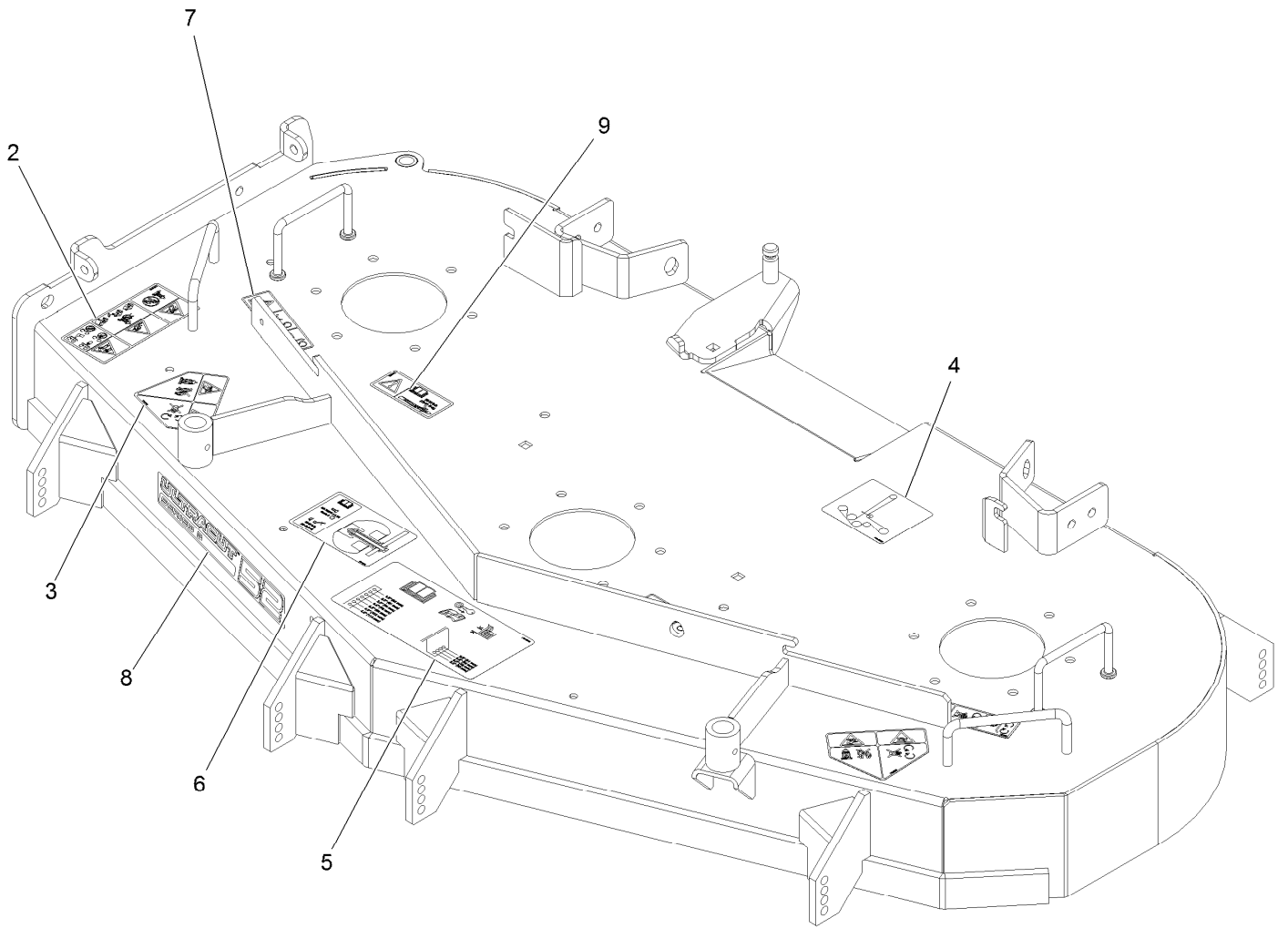



# Deck W/Decals Assembly (continued)

<i>Ref.</i>	<i>Part Number</i>	<i>Qty.</i>	<i>Description</i>
2	135-5210	1	Decal-Warning Thrown Obj
3	112-8760	2	Decal-Danger
4	116-8727	1	Decal-Belt Routing
5	116-8278	1	Decal-Anti-Scalp

<i>Ref.</i>	<i>Part Number</i>	<i>Qty.</i>	<i>Description</i>
6	126-0898	1	Decal-Roller Mounting
7	112-9028	3	Decal-Cover, Missing
8	126-6747	1	Decal-Ultracut 52 Series 3
9	116-8283	1	Decal-Bolt Torque

# Deck Idler Assembly No. 126-2314

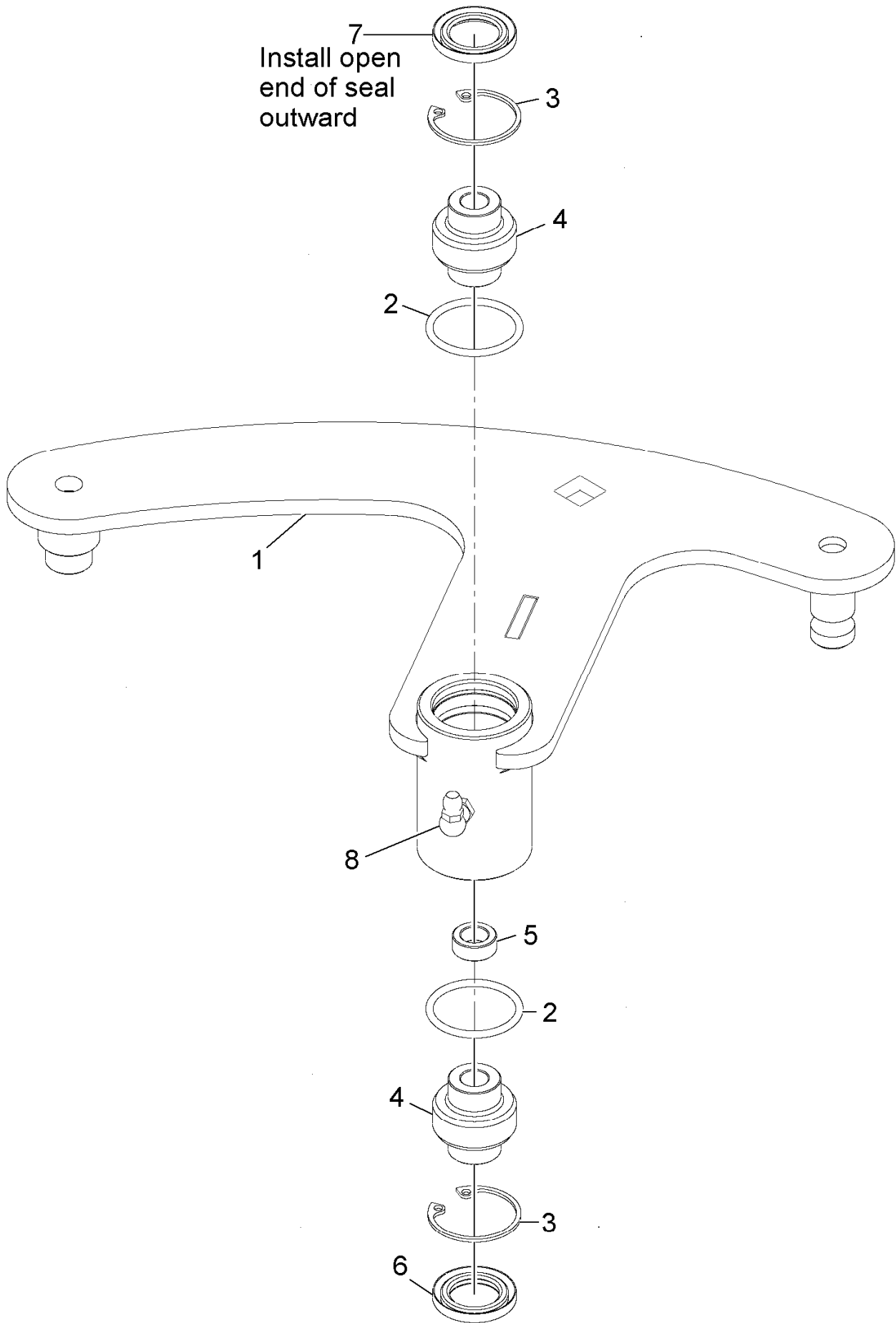

## Deck Idler Assembly No. 126-2314 (continued)

<i>Ref.</i>	<i>Part Number</i>	<i>Qty.</i>	<i>Description</i>	<i>Ref.</i>	<i>Part Number</i>	<i>Qty.</i>	<i>Description</i>
1		1	Weld, Idler Arm ●	5	103-5677	1	Spacer
2	106-7159	2	O-Ring	6	103-3505	1	Seal-Lip, Double
3	32120-10	2	Ring-Snap	7	103-3506	1	Seal-Lip, Single
4	103-3504	2	Bearing-Spherical	8	302-40	1	Fitting-Grease, 90 DEG

● Not serviced separately

# Main Frame Assembly

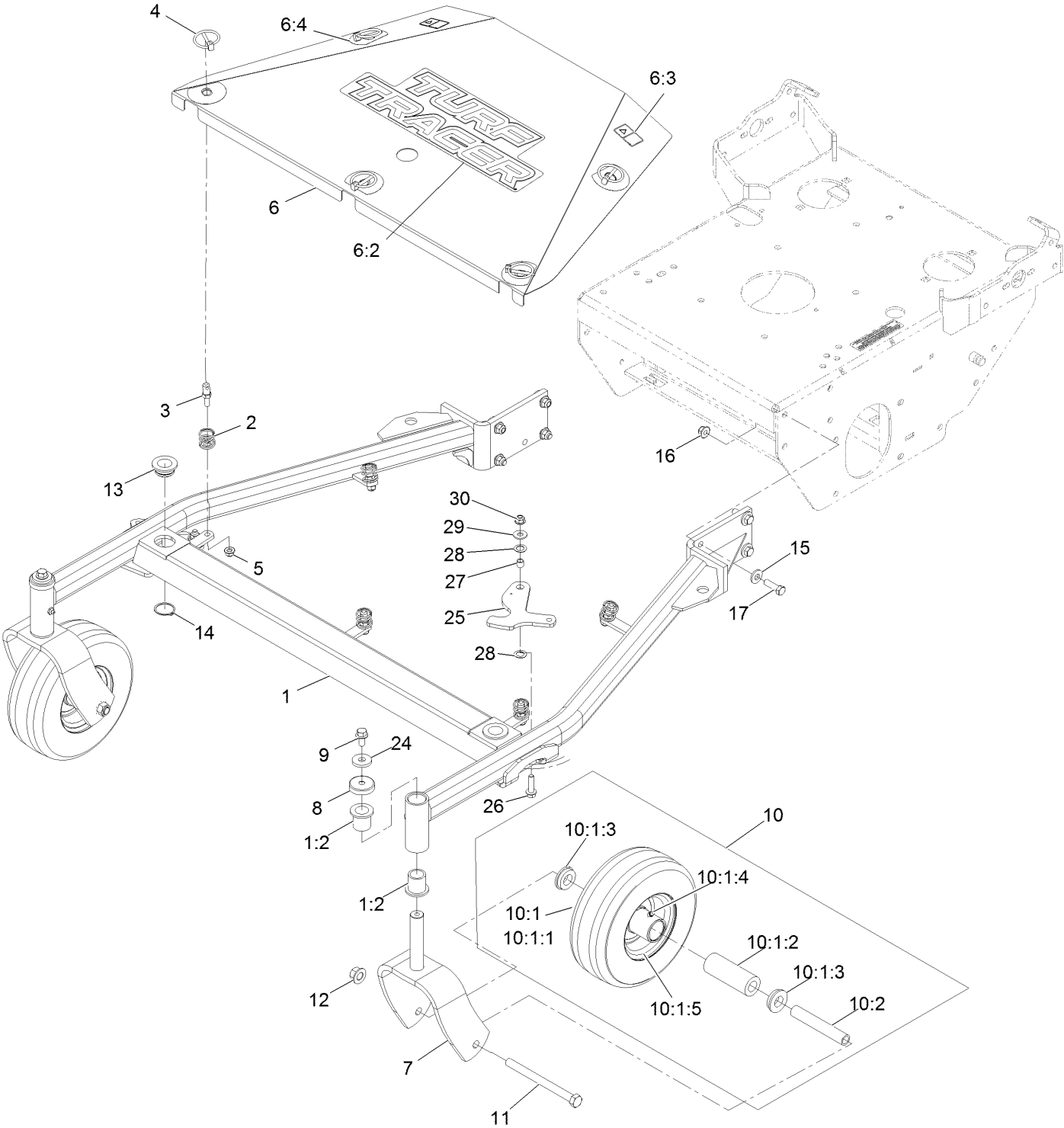

## Main Frame Assembly (continued)

<i>Ref.</i>	<i>Part Number</i>	<i>Qty.</i>	<i>Description</i>	<i>Ref.</i>	<i>Part Number</i>	<i>Qty.</i>	<i>Description</i>
1	126-1515	1	ASM, Frame W/ Bushings, 52	10:1:2	1-513809	1	Bearing
1:2	1-303514	4	Bearing-Flanged	10:1:3	1-513810	2	Bushing-Flanged
2	126-1503	5	Spring	10:1:4	302-61	1	Zerk-45° 1/4-28
3	126-1504	5	Pin-Spring	10:1:5		1	Wheel ●
4	92-1298	5	Pin-Lynch	10:2	1-513547	1	Spacer
5	104-8300	5	Nut-Nyloc 5/16-18 Flg	11	325-20	2	Screw-HH 1/2-13 X 6
6	126-1518	1	ASM, Shield W/ Decals, 52	12	99-5107	2	Nut-Lock 1/2-13
6:2	126-6892	1	Decal-Turf Tracer	13	1-513336	2	Bushing-Deck
6:3	106-5517	2	Decal-Warning	14	32120-33	2	Ring-Retaining
6:4	126-1692	5	Decal-Scratch Cover	15	98-5975	8	Washer-Spring Disc 3/8
7	116-7941-01	2	Fork, Caster [red]	16	104-8301	8	Nut-Nyloc 3/8-16 Flg
8	126-1425	2	Cap, Dust	17	323-7	8	Screw-HH 3/8-16 X 1 1/4
9	110-1718	2	Screw-Hex Flange 3/8-16 X 3/4	24	1-373034	2	Washer
10	1-513547	2	Spacer	25	135-4827-01	2	Latch, Deck Height
10	103-2171	2	Kit,Semi-Pneumatic Wheel Replacement	26	119-4036	2	Screw-HHF
10:1		1	Wheel And Tire ASM ●	27	136-7148	2	Spacer-Grommet
10:1:1		1	Tire ●	28	116-4280	4	Washer-Conical
				29	3256-3	2	Washer-5/16 Std
				30	104-8300	2	Nut-Nyloc 5/16-18 Flg

● Not serviced separately

# Engine Deck

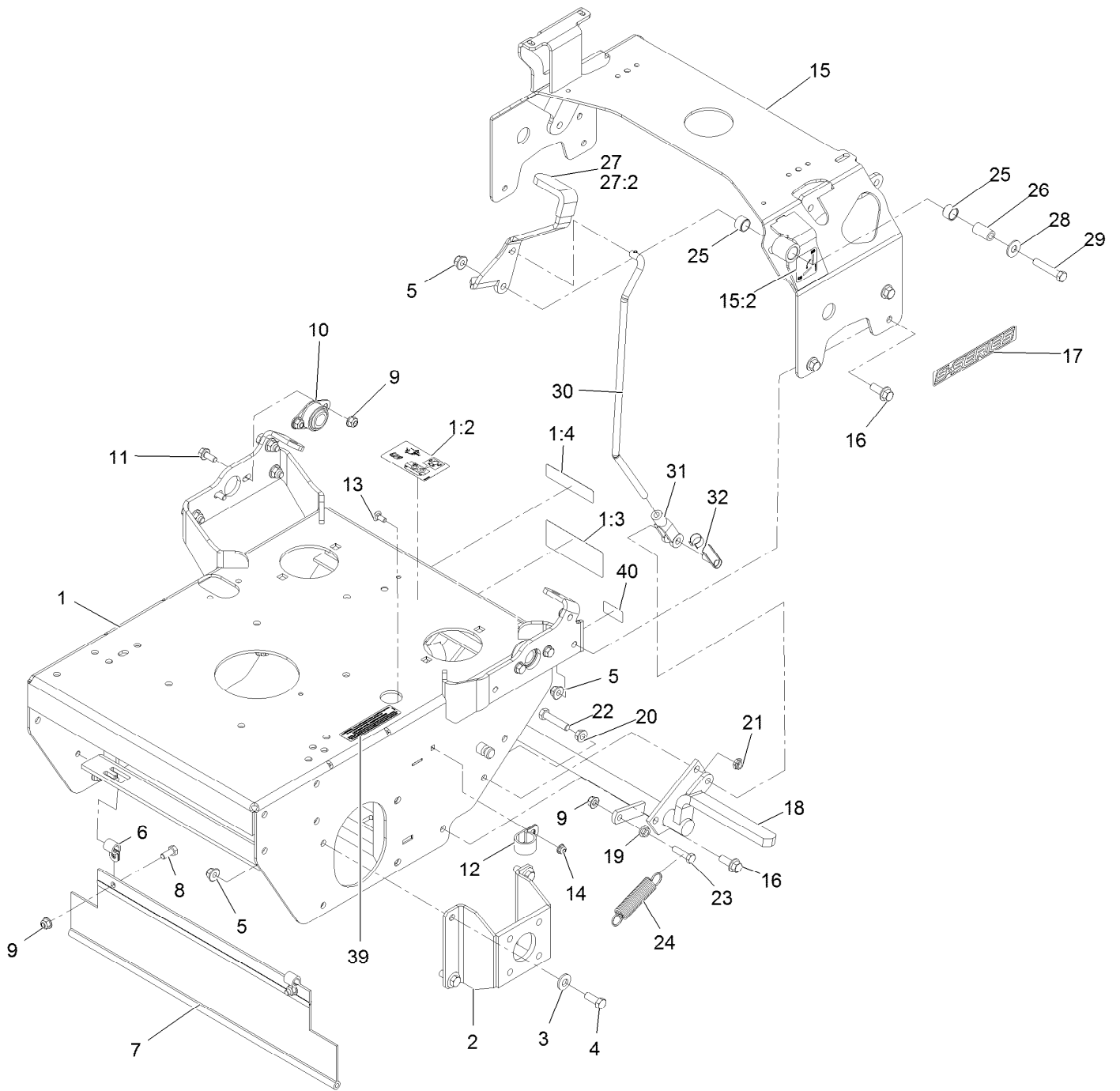

## Engine Deck (continued)

<i>Ref.</i>	<i>Part Number</i>	<i>Qty.</i>	<i>Description</i>	<i>Ref.</i>	<i>Part Number</i>	<i>Qty.</i>	<i>Description</i>
1	126-1238	1	ASM, Engine Deck W/ Decals	16	3234-42	9	Screw HHF 3/8-16 X 1
1:2	116-8253	1	Decal-Drive Release	17	126-6572	2	Decal-S-Series
1:3	126-1400	1	Decal-Warning, Sulky	18	116-9964	1	Brake
1:4	98-1977	1	Decal-Warning	19	32128-20	1	Nut-Whizlock 5/16-18
2	1-412082-01	2	Mount-Wheel Motor	20	3290-357	1	Nut-Whizlock 3/8-16
3	98-5975	8	Washer-Spring Disc 3/8	21	3296-59	1	Nut-Nyloc 3/8-16 Thin
4	323-6	8	Screw-HH 3/8-16 X 1	22	323-9	1	Screw-HH 3/8-16 X 1 3/4
5	104-8301	18	Nut-Nyloc 3/8-16 Flg	23	322-6	1	Screw-HH 5/16-18 X 1 1/4
6	1-413510	2	Clip-Loom	24	1-323161	1	Spring
7	103-2056	1	Shield-Drag	25	1-413347	2	Sleeve-Bushing
8	322-3	2	Screw-HH 5/16-18 X 3/4	26	1-413344	1	Bushing-Pivot
9	104-8300	7	Nut-Nyloc 5/16-18 Flg	27	126-2180	1	ASM, Brake Lever W/ Grip
10	1-633102	2	Bearing-Flanged	27:2	1-303020	1	Grip-Lever
11	3234-47	4	Screw-HH Flg 5/16-18 X 3/4	28	3256-4	1	Washer-3/8 Std
12	1-643312	1	Clip-Loom	29	323-10	1	Screw-HH 3/8-16 X 2
13	3229-11	1	Bolt-Carriage 1/4-20 X 5/8	30	116-9959	1	Linkage, Brake
14	104-7201	1	Nut-Nyloc 1/4-20 Flg	31	1-633131	1	Yoke-Linkage, Brake
15	126-2181	1	ASM, Tank Support W/ Decal	32	103-2399	1	Pin-Clevis Spring 3/8
15:2	116-5988	1	Decal-Park Brake, CE	39	133-8062	1	Decal-Arrestor, Spark
				40	126-4345	1	Decal-Patent

# Handle Assembly

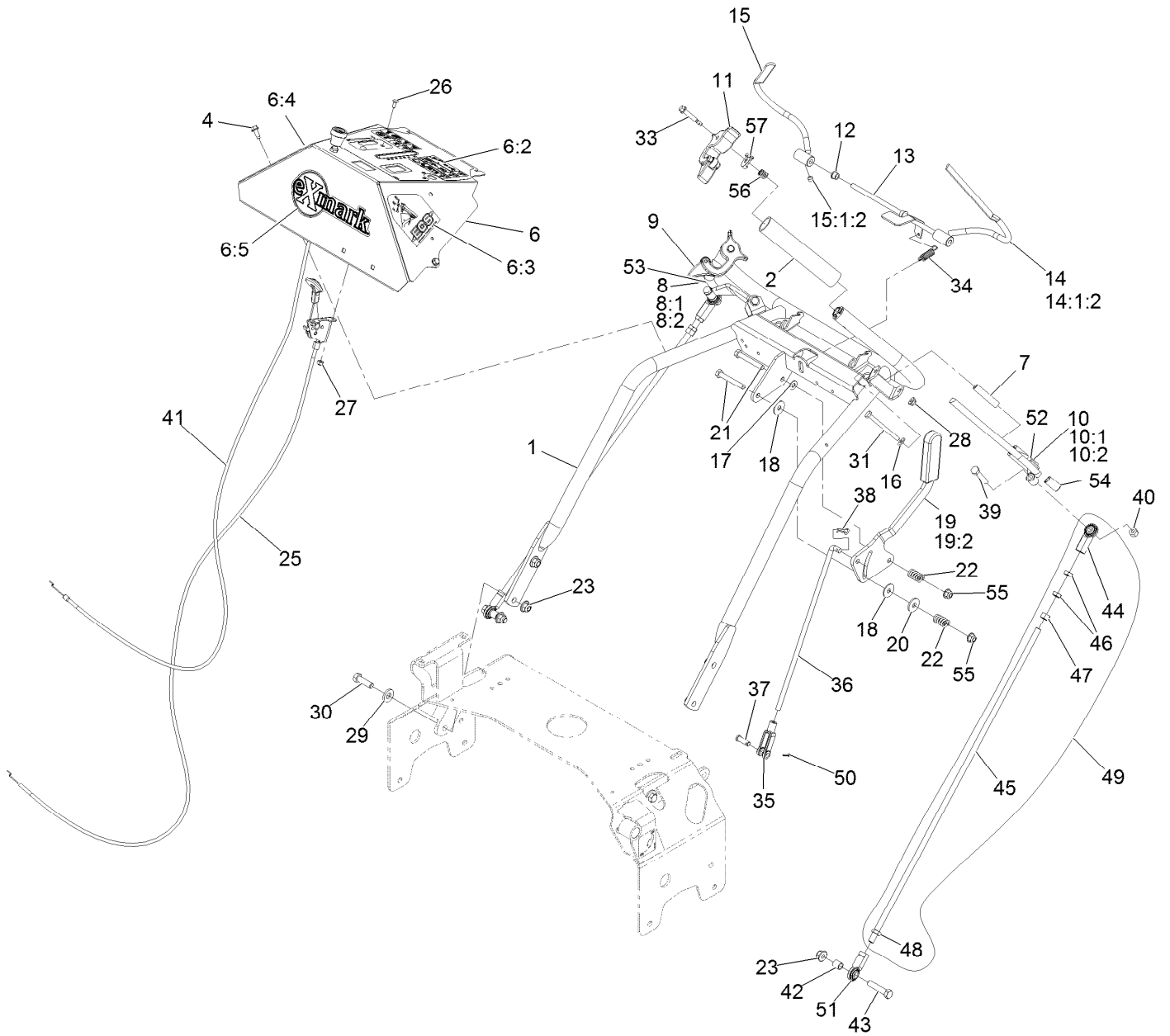



## Handle Assembly (continued)

<i>Ref.</i>	<i>Part Number</i>	<i>Qty.</i>	<i>Description</i>	<i>Ref.</i>	<i>Part Number</i>	<i>Qty.</i>	<i>Description</i>
1	126-2642-03	1	Weld, Handle	25	109-3958	1	Control-Throttle
2	103-0815	2	Grip-Bar, Handle	26	1-807513	2	Bolt-Carriage #10-24 X 1/2
4	32144-10	2	Screw-HWH 1/4-20 X .62	27	3296-2	2	Nut-Nyloc #10-24
6	126-4706	1	ASM, Console W/ Decals	28	104-7201	2	Nut-Nyloc 1/4-20 Flg
6:2	135-2860	1	Decal-Console	29	98-5975	4	Washer-Spring Disc 3/8
6:3	103-2242	1	Decal, Ecs Instruction LH	30	323-7	4	Screw-HH 3/8-16 X 1 1/4
6:4	103-2243	1	Decal, Ecs Instruction RH	31	321-14	2	Screw-HH 1/4-20 X 2 3/4
6:5	126-6877	1	Decal, Exmark Logo	33	126-2931	2	Screw-Shoulder
7	103-0027	2	Bushing-Lever, Drive	34	1-303363	1	Spring-Extension
8	103-2513	1	Asm, Drive Lever RH	35	1-303105	1	Yoke-Adjustable
8:1	116-4082	1	Wld,RH Drive Lever	36	1-413225	1	Rod, Speed Control
8:2	126-9366	2	Bushing, Sleeve	37	1-808280	1	Pin-Clevis 5/16 X 1 49/64
9	103-1371	1	Thumb Latch Asm RH	38	1-806003	1	Hairpin-Cotter
10	103-2514	1	Asm, Drive Lever LH	39	322-9	2	Screw-HH 5/16-18 X 1 3/4
10:1	116-4081	1	Wld,LH Drive Lever	40	3296-29	2	Nut-Nyloc 5/16-18
10:2	126-9366	2	Bushing, Sleeve	41	126-2107	1	Cable, Choke
11	103-1372	1	Thumb Latch Asm LH	42	103-1166	2	Spacer-Tube, Pump Link
12	1-303365	2	Bushing-Nylon	43	323-9	2	Screw-HH 3/8-16 X 1 3/4
13	103-0769-03	1	Rod Weldment, OPC	44	103-2463	2	Balljoint
14	116-4079	1	Wld,LH OPC Lever ■	45	103-1148	2	Rod,Drive Lever
14:1:2	1-803322	1	Setscrew-5/16-24 X 5/16 ●	46	3220-3	4	Nut-Jam 3/8-24
15	116-4080	1	Wld,RH OPC Lever ■	47	3219-3	2	Nut-Hex 3/8-24
15:1:2	1-803322	1	Setscrew-5/16-24 X 5/16 ●	48	3220-16	2	Nut-Jam 3/8-24 LH
16	3256-22	2	Washer-1/4 SAE	49	116-3414	2	Drive Link ASM
17	3256-23	1	Washer-5/16 SAE	50	3272-5	1	Pin-Cotter 3/32 X 1/2
18	1-323244	2	Washer-Friction	51	103-1167	2	Joint-Ball End
19	126-0148	1	Lever, Shift W/Grip	52	116-4081	1	Wld,LH Drive Lever
19:2	103-5994	1	Grip-Handle, Steering	53	116-4082	1	Wld,RH Drive Lever
20	1-603716	1	Washer-Friction Disc	54	126-9366	4	Bushing, Sleeve
21	322-11	2	Screw-HH 5/16-18 X 2 1/4	55	104-8300	2	Nut-Nyloc 5/16-18 Flg
22	1-323245	2	Spring-Compression	56	1-633349	2	Spring-Compression
23	104-8301	6	Nut-Nyloc 3/8-16 Flg	57	126-2921	2	Latch, Ecs

● Use Pro-Lock, Nut Type (P/N 1-840022, .5ml tube) on threads.

■ Use Pro-Lock retaining type, Part no. 1-840023 (.5cc tube) on inside of bore of OPC hub.

# Controls Assembly

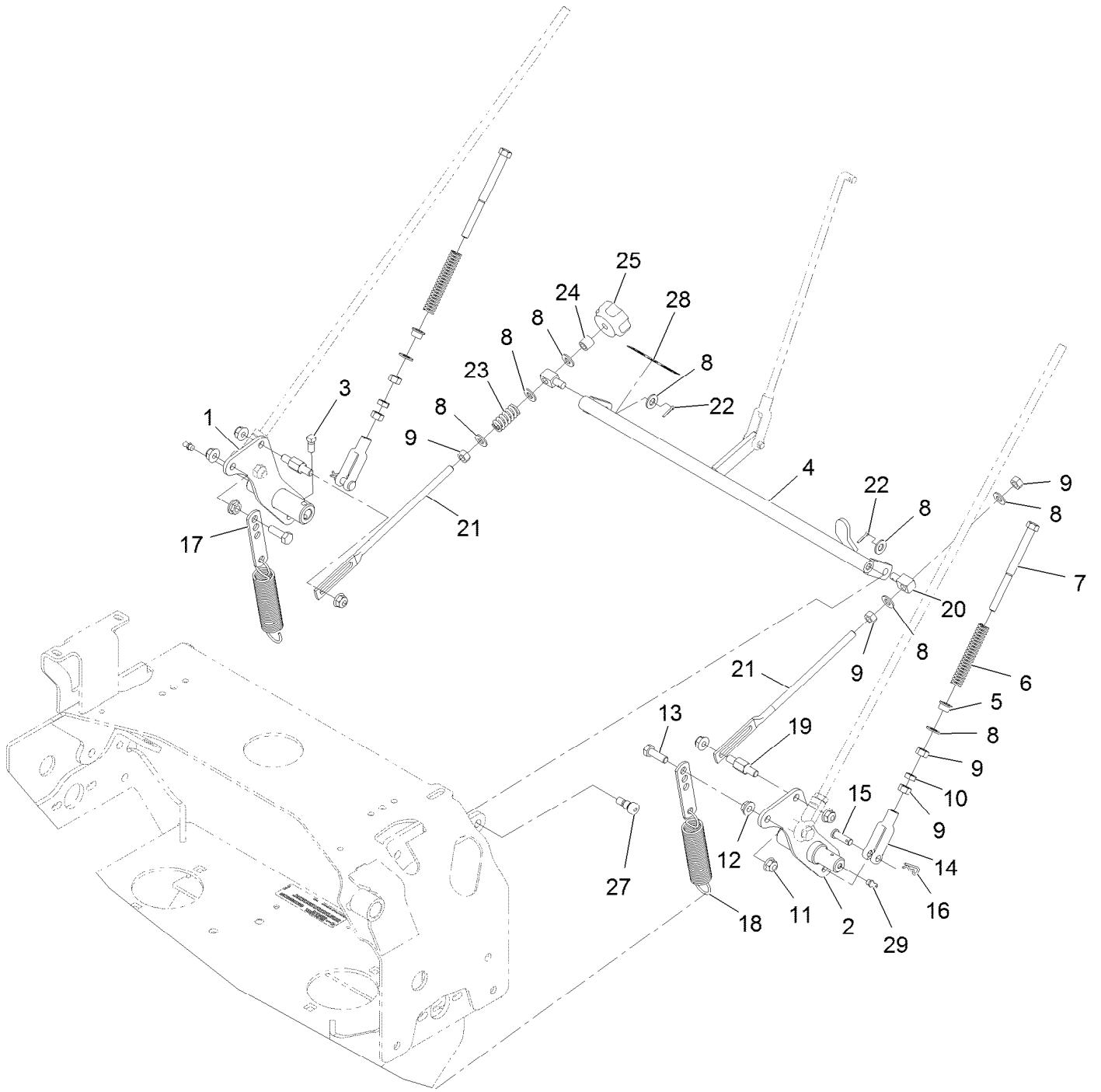

## Controls Assembly (continued)

<i>Ref.</i>	<i>Part Number</i>	<i>Qty.</i>	<i>Description</i>	<i>Ref.</i>	<i>Part Number</i>	<i>Qty.</i>	<i>Description</i>
1	116-9975	1	Weld, Motion Control, Rt	15	1-808280	2	Pin-Clevis 5/16 X 1 49/64
2	116-9974	1	Weld, Motion Control, Lt	16	1-806003	2	Hairpin-Cotter
3	1-803022	2	Setscrew-5/16-18 X 5/8	17	1-613089	2	Tab-Spring, Extension
4	126-2982-01	1	Weld, Speed Control	18	1-603693	2	Spring
5	1-603735	2	Bushing-Flanged	19	126-0610	2	Pin, Motion Control
6	103-0265	2	Spring, Neutral Return	20	126-8571	2	Swivel-Adjustable, Short
7	1-603737	2	Bolt-Neutral Return	21	1-413350	2	Link-Control, Speed
8	3256-23	9	Washer-5/16 SAE	22	3272-5	2	Pin-Cotter 3/32 X 1/2
9	3219-2	7	Nut-Hex 5/16-24	23	1-323245	1	Spring-Compression
10	3220-2	2	Nut-Jam 5/16-24	24	1-603903	1	Spacer
11	104-8300	6	Nut-Nyloc 5/16-18 Flg	25	103-3060	1	Knob-Tracking
12	32128-20	2	Nut-Whizlock 5/16-18	27	1-809056	2	Screw-Sh 5/16-18 X 1 3/8
13	322-5	2	Screw-HH 5/16-18 X 1	28	116-7918	1	Decal-Tracking Adjustment
14	1-303105	2	Yoke-Adjustable	29	302-19	2	Zerk-1/4-28 Str

# Fuel Assembly

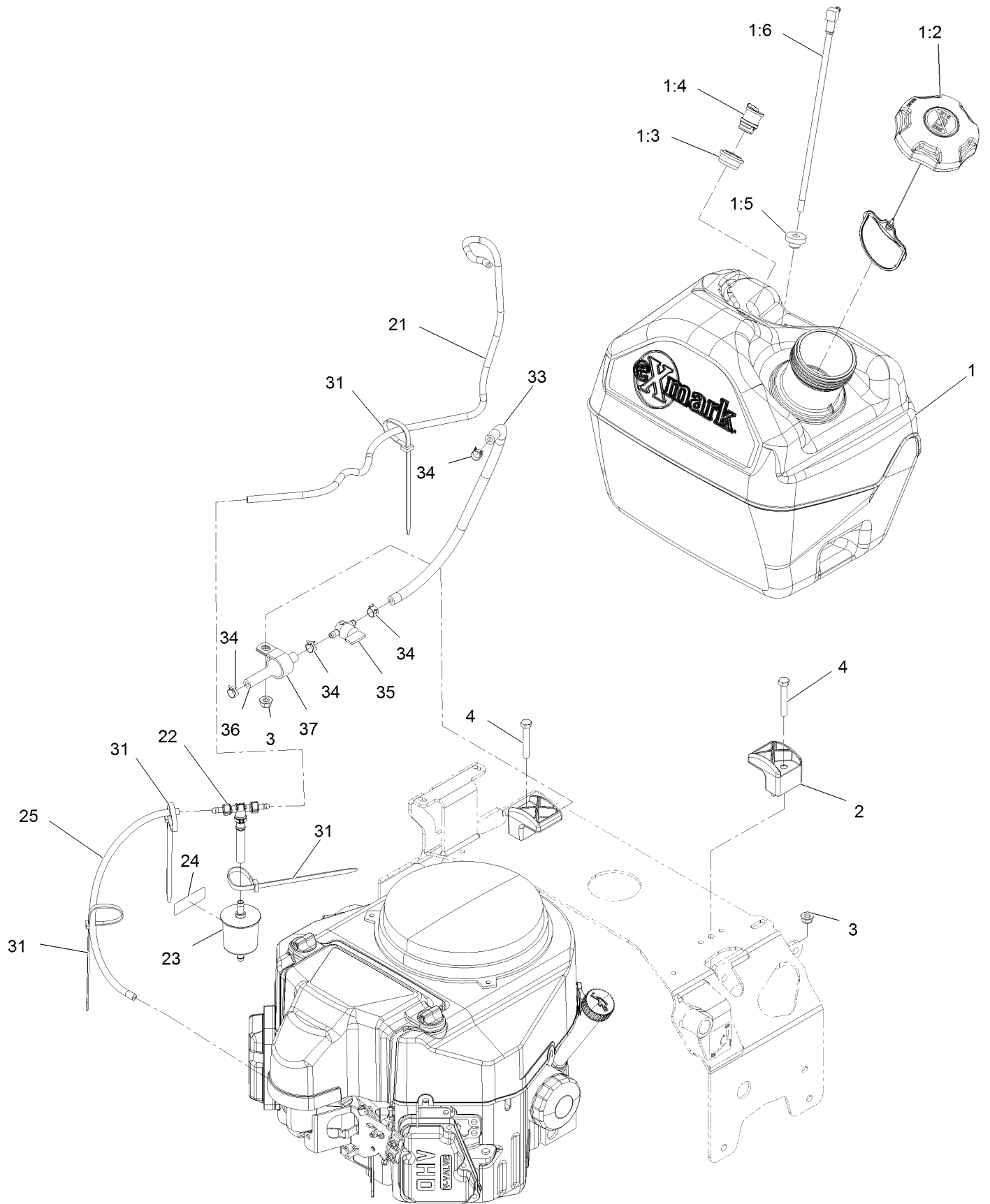

## Fuel Assembly (continued)

<i>Ref.</i>	<i>Part Number</i>	<i>Qty.</i>	<i>Description</i>	<i>Ref.</i>	<i>Part Number</i>	<i>Qty.</i>	<i>Description</i>
1	135-2855	1	ASM, Fuel Tank 5 Gal	22	116-5464	1	Tee And Check
1:2	137-4119	1	Cap-Fuel, Ratcheting	23	120-2235	1	Filter-Fuel
1:3	114-0284	1	Grommet	24	116-4769	1	Decal-Filter, Emissions
1:4	119-3547	1	Valve-Vent, Fuel	25	115-7872	1	Hose-Fuel
1:5	46-6560	1	Bushing	31	1-303335	4	Tie-Cable 7 15/16 (Large)
1:6	109-9364	1	Fitting-Fuel (W/Line And Screen)	33	114-4428	1	Hose-Fuel
2	107-4543	2	Clamp	34	2412-98	4	Clamp-Hose
3	104-8300	2	Nut-Nyloc 5/16-18 Flg	35	1-603770	1	Valve-Fuel
4	322-10	2	Screw-HH 5/16-18 X 2	36	105-8342	1	Hose-Fuel
21	126-1679	1	Hose, Emissions	37	1-643312	1	Clip-Loom

# Engine Assembly

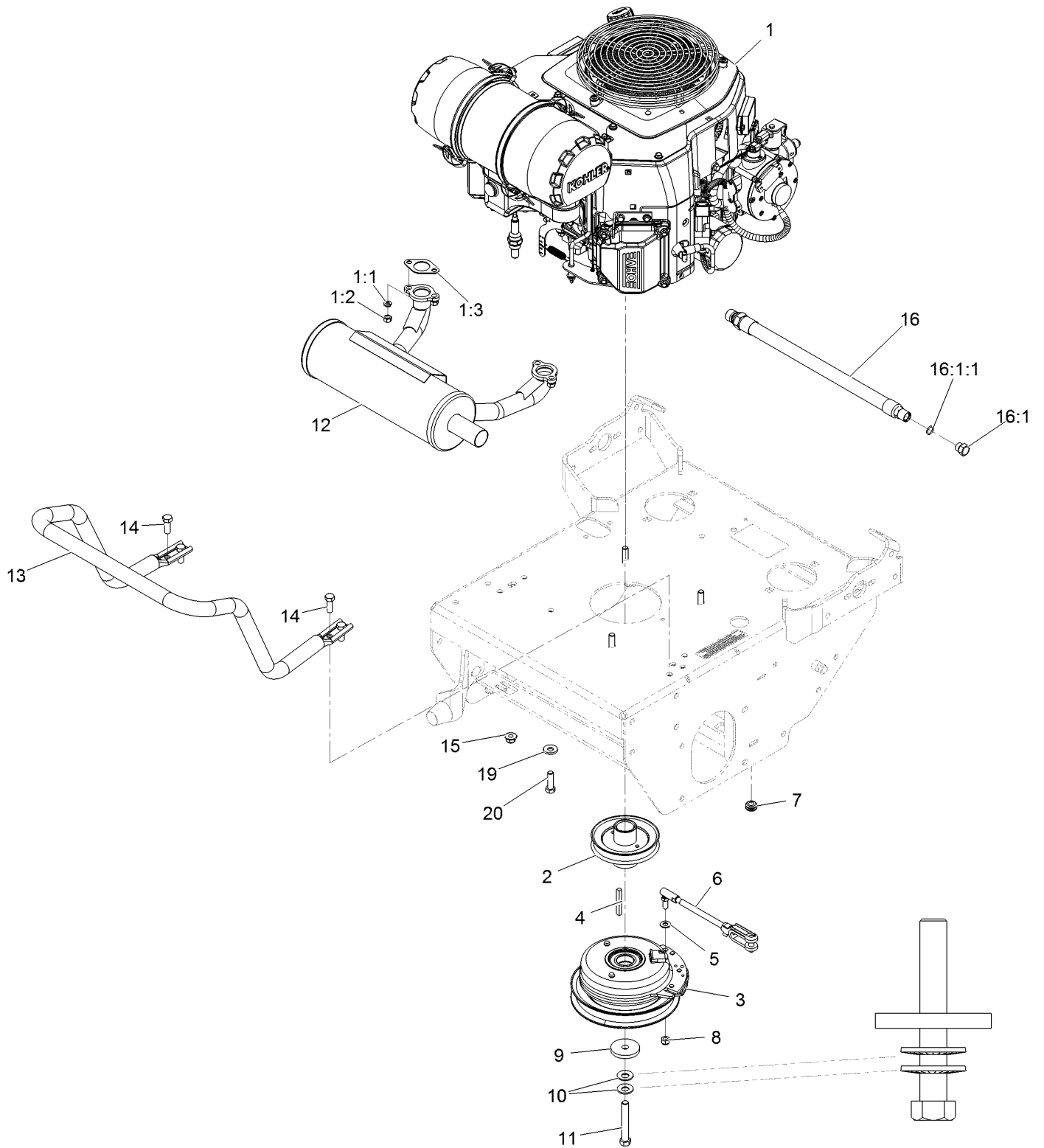

## Engine Assembly (continued)

<i>Ref.</i>	<i>Part Number</i>	<i>Qty.</i>	<i>Description</i>	<i>Ref.</i>	<i>Part Number</i>	<i>Qty.</i>	<i>Description</i>
1		1	Engine, Kawasaki 541Cc ■▲	10	1-603610	2	Washer-Spring Disc 7/16
1:1	114-3550	4	Washer-Spring Lock M8	11	3212-12	1	Screw-HH 7/16-20 X 3 □
1:2	114-3549	4	Nut-M8	12	116-3735	1	Muffler-Horizontal
1:3	1-653313	2	Gasket-Exhaust	13	135-4729-03	1	Tube-Guard Muffler
2	116-7328	1	Sheave, W/ Hub	14	323-6	4	Screw-HH 3/8-16 X 1
3	126-2615	1	Clutch, 105 Ft/Lbs, 1.13	15	104-8301	4	Nut-Nyloc 3/8-16 Flg
4	5-1336	1	Key-Machine 1/4 X 1/4 X 2 ○	16	116-5052	1	Asm-Oil Drain Hose W/Plug ◆
5	3256-23	1	Washer-5/16 SAE	16:1	353-508	1	Plug-W/O-Ring ●
6	126-0620	1	ASM, Clutch Anchor	16:1:1	237-42	1	O-Ring
7	237-136	1	Grommet	19	98-5975	4	Washer-Spring Disc 3/8
8	3296-4	1	Nut-Lock 5/16-24	20	323-7	4	Screw-HH 3/8-16 X 1 1/4
9	109-6919	1	Washer-Clutch				

● Torque to 20-24 ft-lb

■ Not serviced separately

▲ Obtain parts from [www.kawpowerepc.com](http://www.kawpowerepc.com)

◆ Use a Teflon Pipe Sealant or equivalent on threads.

□ Use Pro-Lock, Nut Type (P/N 1-840022, .5ml tube) on threads.

○ Apply anti-seize compound to engine crankshaft, pulley hub I.D., clutch bore I.D. and square key.

# Ground Drive Assembly

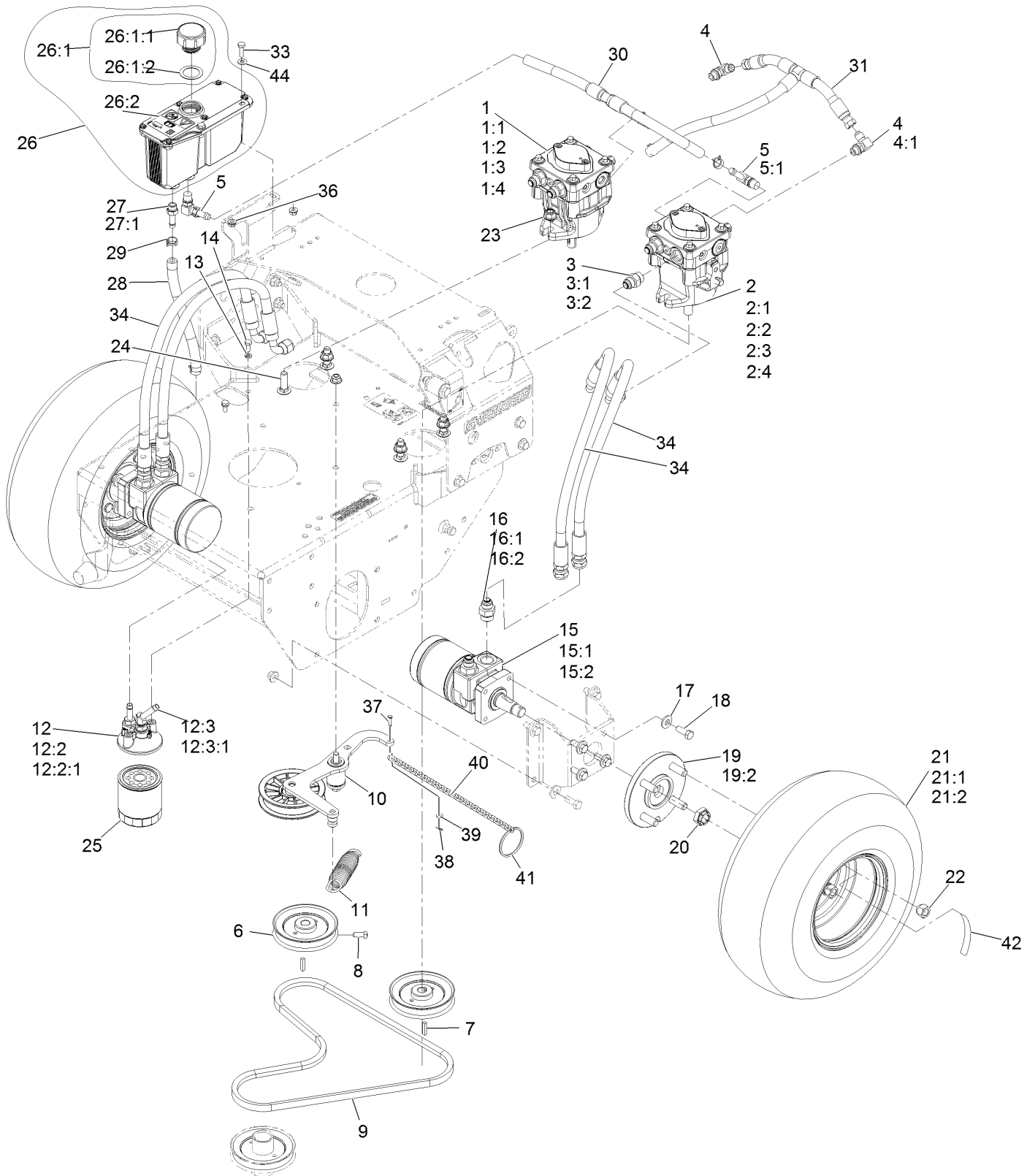



## Ground Drive Assembly (continued)

<i>Ref.</i>	<i>Part Number</i>	<i>Qty.</i>	<i>Description</i>	<i>Ref.</i>	<i>Part Number</i>	<i>Qty.</i>	<i>Description</i>
1	116-0943	1	RH HYD Pump ASM	16:2	1-603992	1	O-Ring-37 Flare #8
1:1	103-2664	1	Input Shaft Kit	17	98-5975	8	Washer-Spring Disc 3/8
1:2	94-6922	1	Bearing-Thrust	18	323-6	8	Screw-HH 3/8-16 X 1
1:3	103-2666	1	Cylinder Block Kit	19	112-9049	2	Wheel Hub ASM
1:4	105-6184	1	Seal Overhaul Kit	19:2	1-633926	4	Stud-Wheel
2	116-0942	1	LH HYD Pump ASM	20	116-2839	2	Nut-Lock
2:1	103-2664	1	Input Shaft Kit	21	1-613263	2	Wheel And Tire ASM
2:2	94-6922	1	Bearing-Thrust	21:1	1-613264	1	Tire-Turfmaster
2:3	103-2666	1	Cylinder Block Kit	21:2	1-603715	1	Rim-Wheel
2:4	105-6184	1	Seal Overhaul Kit	22	242-50	8	Nut-Lug 1/2-20
3	1-603990	4	Adapter-Straight	23	114-8417	4	Nut-HF, NI
3:1	1-603920	1	O-Ring-SAE #8	24	3232-3	4	Bolt-Carriage 7/16-14 X 1 1/2
3:2	1-603992	1	O-Ring-37 Flare #8	25	109-4180	1	Element, Oil Filter
4	103-1802	2	Fitting-Elbow, 90 DEG	26	126-1248	1	ASM, HYD Reservoir ■
4:1	237-42	1	O-Ring	26:1		1	Reservoir-HYD ●
5	100-4887	3	Fitting-Elbow, 90	26:1:1	103-1948	1	Cap-Reservoir, HYD
5:1	237-42	1	O-Ring	26:1:2	103-1949	1	Gasket-Cap
6	1-413010	2	Sheave ASM	26:2	115-4212	1	Decal-Warning
7	1-807272	2	Key-5Mm X 5Mm X 25Mm	27	103-1912	1	Adapter-Straight
8	120-6474	4	Screw-Set, SQH 5/16-18 X 3/4	27:1	237-42	1	O-Ring
9	103-4761	1	Belt	28	103-2959	1	Hose-Charge
10	126-0615	1	ASM, Pump Idler	29	103-1988	6	Clamp-Hose 11/16
11	116-6316	1	Spring-Extension	30	126-0623	1	Hose-Case Drain
12	126-0621	1	ASM, Filter Head	31	126-0622	1	Hose-Charge
12:2	103-1912	1	Adapter-Straight	33	321-5	2	Screw-HH 1/4-20 X 7/8
12:2:1	237-42	1	O-Ring	34	119-7827	4	HYD Hose ASM
12:3	103-1807	1	Fitting-Barbed, 45 DEG	36	32128-32	2	Nut-Hex 1/4-20 Side Lock
12:3:1	237-42	1	O-Ring	37	283-16	1	Pin-Clevis
13	1-805004	2	Washer-Lock 1/4 Heavy	38	108-2992	1	Pin-Hair
14	321-3	2	Screw-HH 1/4-20 X 5/8	39	3269-26	1	Washer-Plain
15	1-603718	2	HYD Motor ASM	40	1-323365	1	Chain-Link, Twist
15:1	1-000119	1	Seal Kit	41	1-323366	1	Ring-Split
15:2	1-000138	1	Bearing And Seal Kit	42	126-2056	2	Decal-Torque Wheel Lug-Hub
16	1-603991	4	Adapter-Straight	44	3256-22	2	Washer-1/4 SAE
16:1	237-80	1	O-Ring				

● Not serviced separately

■ Use Exmark Premium Hydro Oil P/N 109-9828 (32oz)

# Pump Idler Assembly No. 126-0615

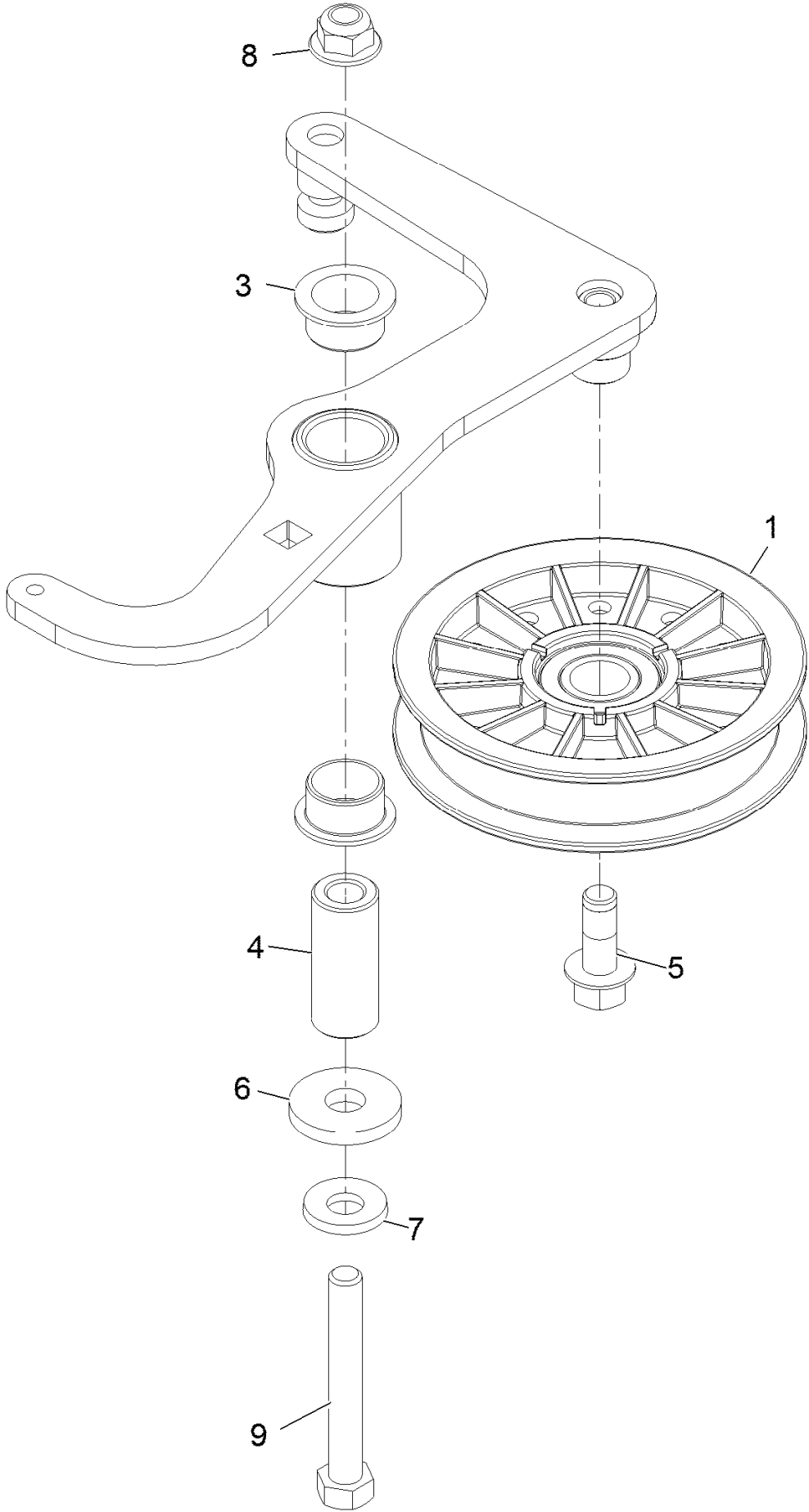

## Pump Idler Assembly No. 126-0615 (continued)

<i>Ref.</i>	<i>Part Number</i>	<i>Qty.</i>	<i>Description</i>	<i>Ref.</i>	<i>Part Number</i>	<i>Qty.</i>	<i>Description</i>
1	109-4077	1	Pulley-Idler, Flat	6	1-373034	1	Washer
3	109-8054	2	Bushing-Flanged	7	98-5975	1	Washer-Spring Disc 3/8
4	116-8718	1	Spacer, Pivot	8	104-8301	1	Nut-Nyloc 3/8-16 Flg
5	126-1680	1	Screw-Hfh	9	112-7451	1	Screw-TAP

# Electrical Assembly

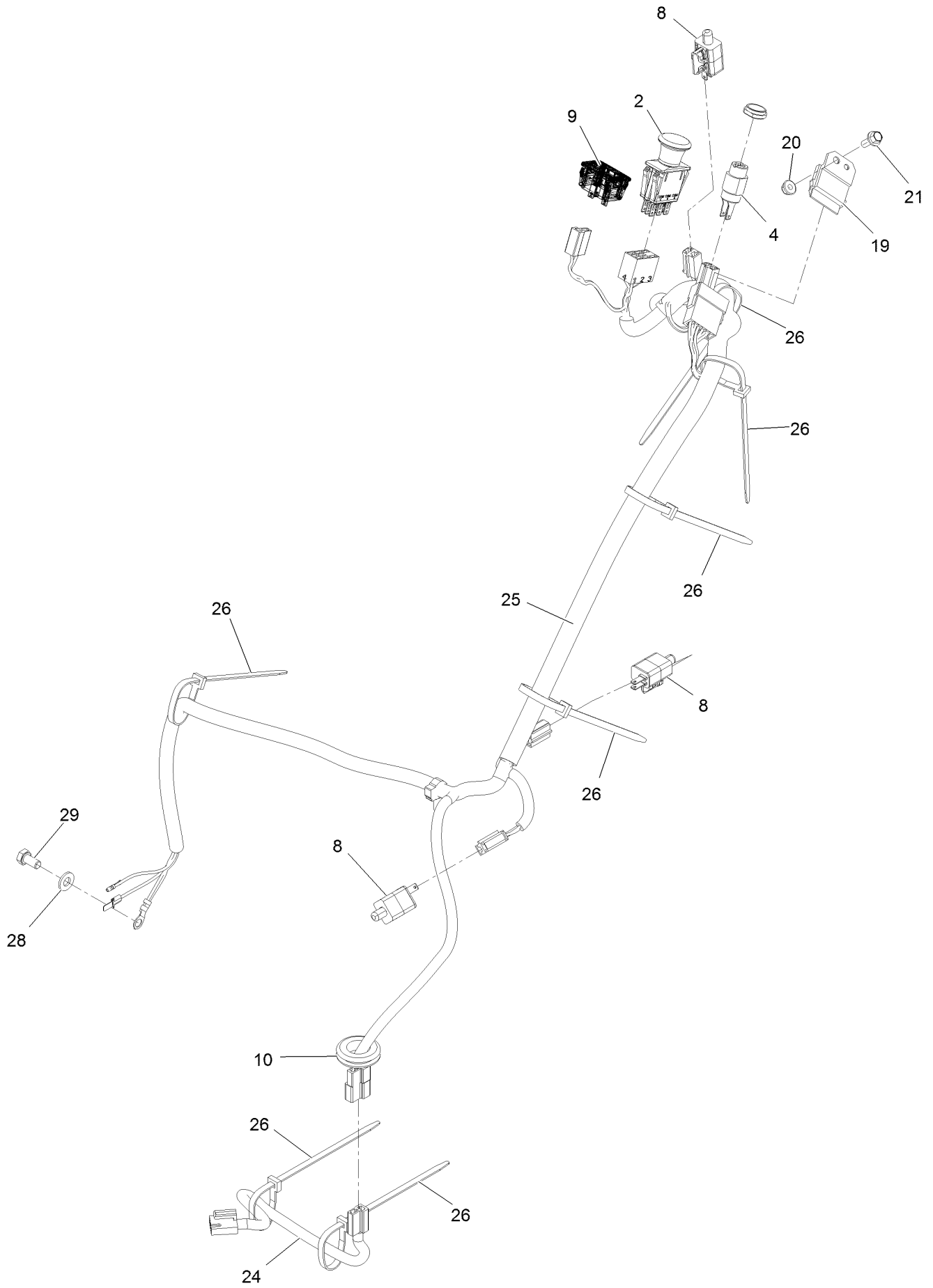

## Electrical Assembly (continued)

<i>Ref.</i>	<i>Part Number</i>	<i>Qty.</i>	<i>Description</i>	<i>Ref.</i>	<i>Part Number</i>	<i>Qty.</i>	<i>Description</i>
2	103-5221	1	Switch-PTO	20	104-7201	1	Nut-Nyloc 1/4-20 Flg
4	1-403121	1	Switch & Key (Includes Nut & Washer)	21	99-6810	1	Screw-HH 1/4-20 X 5/8
4	103-0498	1	Nut-Ignition	24	126-0624	1	Harness-Clutch Pigtail
8	110-6765	3	Switch	25	126-0625	1	Harness-Main ●
9	126-3931	1	Meter-Hour	26	1-303335	7	Tie-Cable 7 15/16 (Large)
10	1-543286	1	Grommet	28	33094-00	1	Washer
19	1-323430	1	Module-Interlock	29	33114-016	1	Screw-HH M8-1.25 X 16Mm

● Use dielectric grease on all unsealed connectors and terminals only. Do not apply in sealed connectors.

**Notes:**



# MAXIMIZE THE PERFORMANCE OF YOUR EXMARK MACHINE.



## EXMARK® PREMIUM ENGINE OIL

Exmark now offers a family of engine oil viscosities to perform well in any environment. Each viscosity has the same synthetic formulation to give you what you need in punishing conditions. We designed each grade to the highest quality, making it ideal even for diesel applications. Coupled with Exmark Premium Fuel Treatment, we have the performance products to make your machine hum.

### EXMARK PREMIUM ENGINE OIL SAE 30/10W-30

- Meets zero shear requirements of a straight grade SAE 30 as well as the cold temp properties of a 10W-30.
- Most versatile oil in the industry.
- Superior corrosion protection over conventional oil - even in corrosive, humid environments.

### EXMARK PREMIUM ENGINE OIL SAE 20W-50

- Perfect for your big block engine, or any application in severe service.
- Same full synthetic formulation as all other Exmark Premium viscosities.
- Also effective for use in severe service small block engines.

### EXMARK PREMIUM ENGINE OIL SAE 10W-50

- Full synthetic formulation gives you peak performance. Don't settle for less.
- Wide span multi-grade combines easy starting in cold weather with maximum protection in high temperature operation.
- Reduce friction & wear over standard mineral formulations.

### EXMARK PREMIUM ENGINE OIL SAE 0W-40

- The perfect choice for when the weather turns cold or unpredictable, and your Exmark UTV has to perform.
- Commercial quality for severe service.
- Advanced additive package helps prevent corrosion from long-term storage.

### EXMARK PREMIUM ENGINE OIL UTV FORMULATION

- 4-cycle high-temp formulation.
- Heavier viscosity, full synthetic, perfect for your UTV.

### EXMARK PREMIUM UTV EXTREME CONDITIONS GEAR OIL

- SAE 80W-90, designed to keep your UTV performing at its peak.
- Shear stable, hypoid gear lube.
- Includes a premium additive system to combat wear, oxidation, rust & corrosion.

**Available from your local Exmark dealer. Find your closest dealer at [exmark.com](http://exmark.com)**

## EXMARK ACCESSORIES AND OPTIONS\*

### MID-MOUNT RIDING ACCESSORIES AND OPTIONS

CUSTOM RIDE SEAT SUSPENSION SYSTEM	OPERATOR CONTROLLED DISCHARGE
FULL SUSPENSION SEAT	SUN SHADE
DECK LIFT ASSIST KIT	TRASH CONTAINER
HITCH KIT	TURF STRIPER
LIGHT KIT	ULTRA VAC COLLECTION SYSTEM
12V POWER PORT	ULTRA VAC QUICK DISPOSAL SYSTEM
MICRO-MULCH SYSTEM	

### OUT-FRONT RIDING ACCESSORIES AND OPTIONS

CUSTOM RIDE SEAT SUSPENSION SYSTEM	SNOW BLADE
DUAL-TAIL WHEEL	SNOWBLOWER
FLOOR PAN EXTENDER	SUN SHADE
HITCH KIT	TRASH CONTAINER
LIGHT KIT	ULTRA VAC COLLECTION SYSTEM
MICRO-MULCH SYSTEM	ULTRA VAC QUICK DISPOSAL SYSTEM
ROLL OVER PROTECTION SYSTEM (ROPS)	WEATHER CAB

### WALK-BEHIND ACCESSORIES AND OPTIONS

GRASS CATCHER	TURF STRIPER
MICRO-MULCH SYSTEM	STANDON

\*Some accessories and options not available for some models.

Place Model No. and Serial No.  
Label Here (Included in the Literature  
Pack) or Fill in Below

Model No. \_\_\_\_\_

Serial No. \_\_\_\_\_

Date Purchased \_\_\_\_\_

Engine Model No. and Spec. No. \_\_\_\_\_

Engine Serial No. (E/No) \_\_\_\_\_

© 2018 Exmark Mfg. Co., Inc.  
2101 Ashland Ave  
Beatrice, NE 68310  
All Rights Reserved

Part No. 4503-976 Rev. A  
(402) 223-6375  
Fax (402) 223-5489  
Printed in the USA.

