

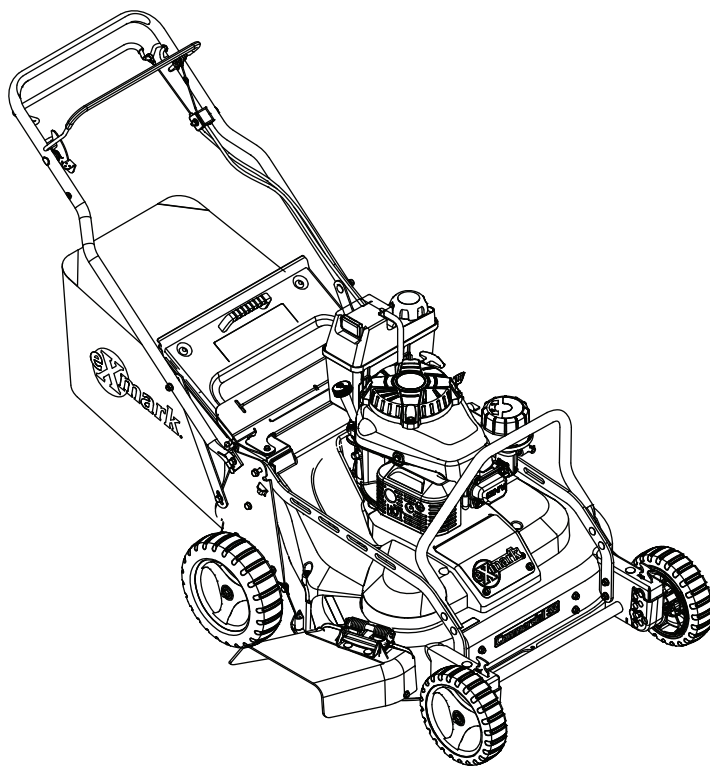

COMMERCIAL 30

Model No. ECS180CKA30000—Serial No. 404314159 and Up

Picture below may not reflect actual product.



Parts Manual

Part No. 4503-962 Rev. B

Ordering Replacement Parts

To order replacement parts, please supply the part number, the quantity, and the description of each part desired.

Understanding Reference Numbers

Each identified part in an illustration has a reference number. The reference number for a part also appears in the parts list, along with other information about the part.

This catalog uses two special reference number formats, one to indicate parts in a service assembly and another to indicate the quantity of a given part in an illustration.

Service Assembly Reference Numbers

Parts in service assemblies have reference numbers in the form a:b. The a represents the reference number of the entire service assembly and the b represents a sequential number unique to each part within the service assembly.

For example, a wheel assembly might be identified by reference number 6, the tire by 6:1, the valve by 6:2, and the wheel by 6:3. When you order the assembly identified by reference number 6, you receive all parts identified by reference numbers 6:1, 6:2, and 6:3. However, you may also order any part individually. Reference numbers of this type appear in illustration and in parts lists.

Reference Numbers Indicating Quantity

In an illustration, if a reference number indicates more than one part, the reference number has the form nX y. The n represents the quantity of the part, the X is the multiplication symbol, and the y represents the reference number.

For example, in an illustration, the reference number 2X 37 means that two of the parts identified by reference number 37 are indicated.

Touch Up Paint

Exmark black touch up spray paint – gloss black.

Exmark red touch up paint (spray paint – P/N 1-850337 - .6 oz liquid bottle – P/N 103-9140).



If your Exmark dealer does not have the Exmark part in stock, Exmark will get the parts to the dealer the next business day or the part will be FREE Guaranteed!! (Some restrictions apply. See your participating Exmark Dealer for details.)

Contents

Deck, Frame, and Chute Assembly	4
Deck W/Decals Assembly	6
Spindle and Blade Assembly	8
Pulleys and Idler Assembly No. 126-7890	10
Side Discharge Chute Assembly	12
Bag Assembly	14
Engine and Fuel Tank Assembly	16
Front Bumper and Wheel Assembly	18
Deck and Wheel Assembly	20
Handle Assembly	22

Deck, Frame, and Chute Assembly

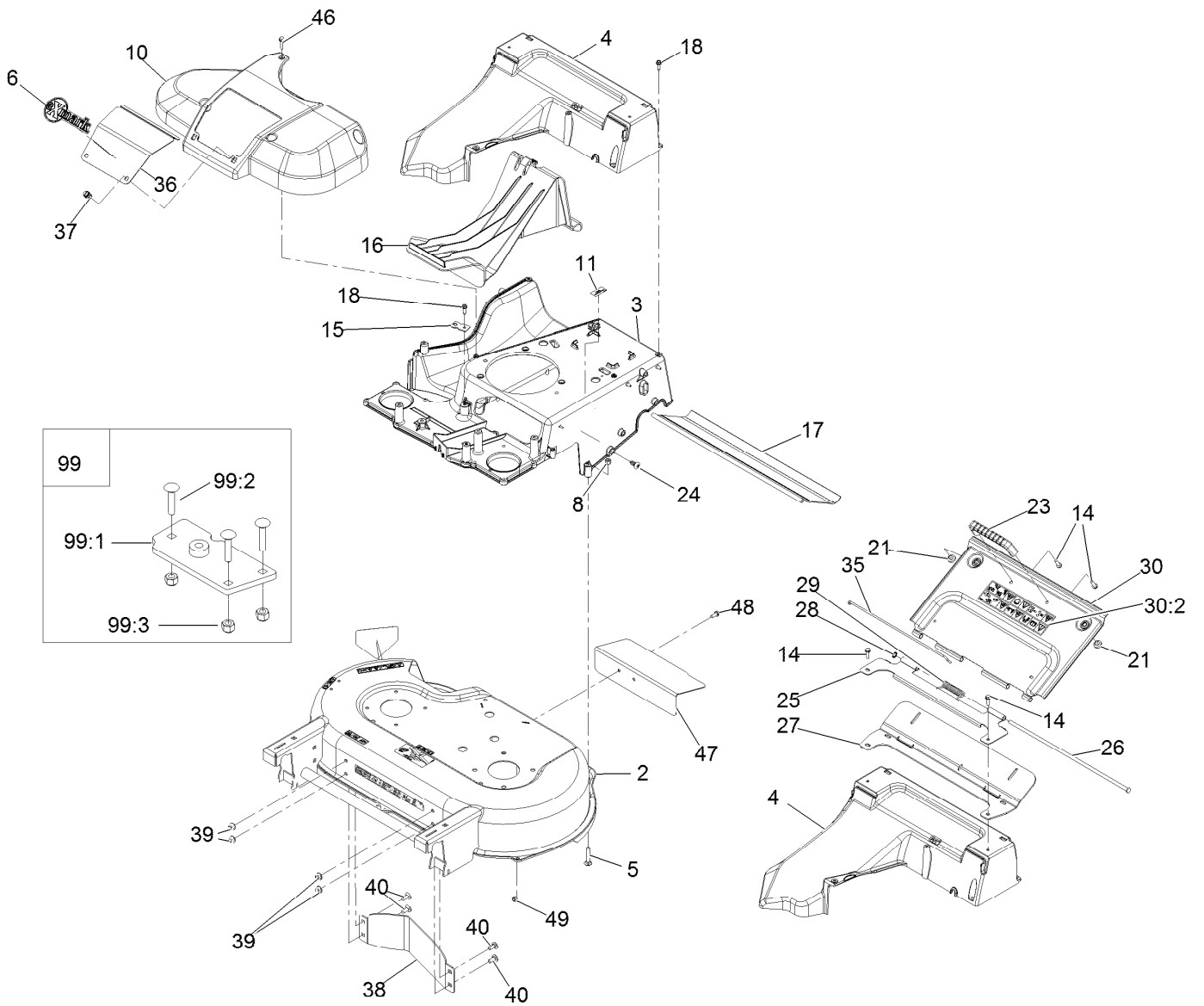

Deck, Frame, and Chute Assembly (continued)

<i>Ref.</i>	<i>Part Number</i>	<i>Qty.</i>	<i>Description</i>	<i>Ref.</i>	<i>Part Number</i>	<i>Qty.</i>	<i>Description</i>
2	126-7582	1	Deck-30, W/Decals	27	116-6229	1	Seal-Door
3	136-5908-01	1	Frame	28	32151-72	1	Ring-Retaining
4	133-8177	1	Chute	29	116-7573	1	Spring-Torsion, Cover
5	3230-5	2	Bolt-Carriage 5/16-18 X 1 3/4	30	116-8355	1	Rear Door ASM
6	126-6575	1	Decal-Exmark Logo	30:2	116-7583	1	Decal-Warning
8	3296-29	2	Nut-Nyloc 5/16-18	35	116-6966	1	Clip-Seal
10	121-5810	1	Cover-Belt	36	121-5793-03	1	Door-Access
11	126-4345	1	Decal-Patent	37	121-5840	2	Fastener
14	46-8091	4	Screw-HWH 1/4-10 X .82 Plastite	38	130-2352-01	1	Baffle-Control
15	138-3224	1	Bracket-Cable, Traction	39	104-8300	4	Nut-Nyloc 5/16-18 Flg
16	120-5225	1	Plug-Mulch	40	3274-55	4	Screw-Button Head 5/16-18 X 3/4
17	121-5841	1	Shield-Trailing	46	32144-86	1	Screw-HWH 1/4-20 X 1 Tf
18	49-2040	8	Screw-HWH 1/4-20 X 3/4 Tf	47	126-6381-01	1	Deflector-Rear
21	1-513658	2	Bumper	48	32144-85	2	Screw-HWH 1/4-20 X .62
23	65-5100	1	Handle-Door	49	3296-42	2	Nut-Nyloc 1/4-20
24	117-1092	2	Screw-PTH	99	125-5072	1	Frame Plate Kit
25	116-6351-03	1	Bracket-Hinge	99:1	125-2542	1	Plate-Frame
26	116-6933	1	Pin-Hinge	99:2	3229-3	3	Bolt-Carriage 1/4-20 X 1 1/4
				99:3	3296-42	3	Nut-Nyloc 1/4-20

Deck W/Decals Assembly

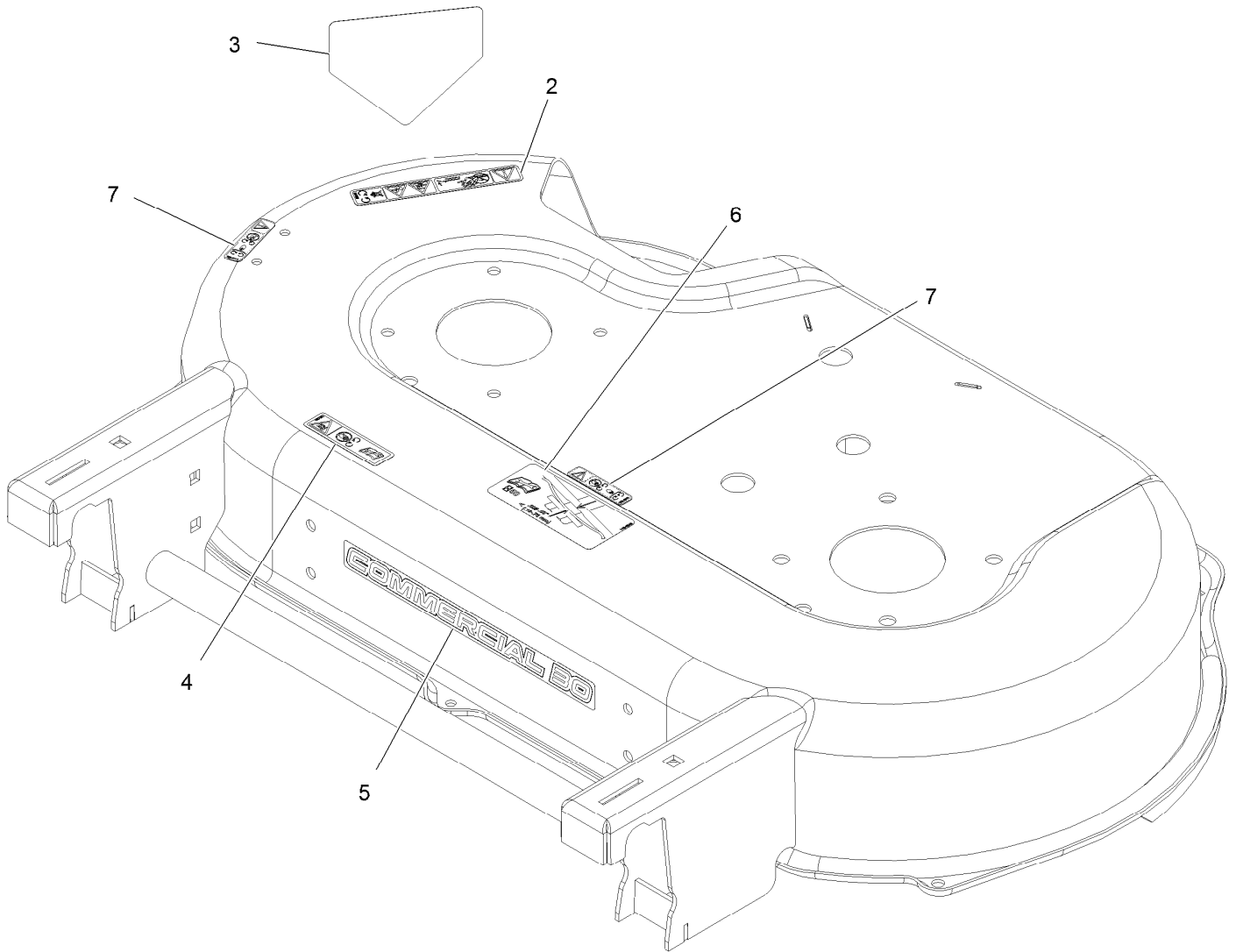

Deck W/Decals Assembly (continued)

<i>Ref.</i>	<i>Part Number</i>	<i>Qty.</i>	<i>Description</i>	<i>Ref.</i>	<i>Part Number</i>	<i>Qty.</i>	<i>Description</i>
2	93-7009	1	Decal-Danger	5	126-6889	1	Decal-Commercial 30
3	94-8072	1	Decal-Danger	6	116-8528	1	Decal
4	116-7581	1	Decal-Warning	7	120-9570	2	Decal-Warning

Spindle and Blade Assembly

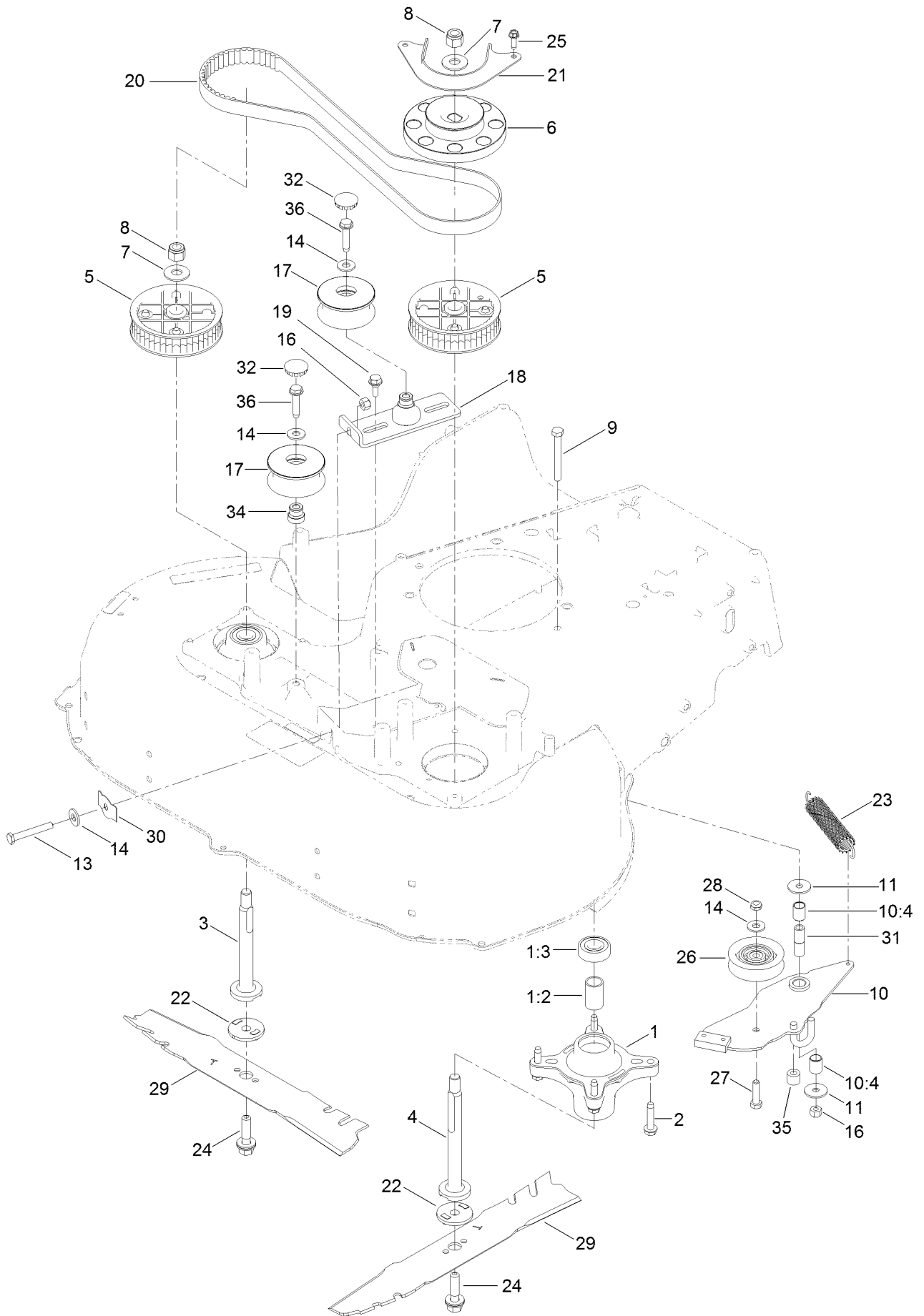

Spindle and Blade Assembly (continued)

<i>Ref.</i>	<i>Part Number</i>	<i>Qty.</i>	<i>Description</i>	<i>Ref.</i>	<i>Part Number</i>	<i>Qty.</i>	<i>Description</i>
1	121-9107	2	Spindle ASM	18	126-6453	1	Bracket-Idler
1:2	120-7935	2	Spacer	19	120-7024	2	Screw-Shoulder, HWH
1:3	136-5441	2	Bearing-Ball	20	120-3335	1	Belt-Synchronous
2	132-4498	8	Screw-HWH	21	120-5245-03	1	Guide-Belt, Spindle
3	120-5234	1	Shaft-Spindle	22	120-5236	2	Adapter-Blade
4	120-5235	1	Shaft-Spindle	23	121-5808	1	Spring-Extension, Brake
5	121-9100	2	Sprocket	24	125-2466	2	Bolt-Blade
6	130-6664	1	Pulley-Brake, Spindle	25	49-2040	2	Screw-HWHTF
7	109-9505	2	Washer-Spring	26	120-7082	1	Pulley-Idler
8	3296-19	2	Nut-Hex	27	322-6	1	Screw-HH
9	322-13	1	Screw-HH	28	3296-47	1	Nut-Lock, NI
10	136-5903	1	Brake Arm ASM	29	116-6358-03	2	Blade-Rotary
10:4	131-0819	2	Bushing-Sleeve	30	121-2336	1	Spring-Flat
11	5-4460	2	Washer-Pivot	31	131-0823	1	Spacer-Brake
13	9114524	1	Bolt-TAP, HH	32	126-7151	2	Plug-Button
14	3256-3	4	Washer-Flat	34	131-4504	1	Adapter-Bore
16	3296-29	2	Nut-Lock, NI	35	133-1964	1	Hose-Coolant
17	126-7890	1	Pulleys And Idler Kit	36	32144-57	2	Screw

Pulleys and Idler Assembly No. 126-7890

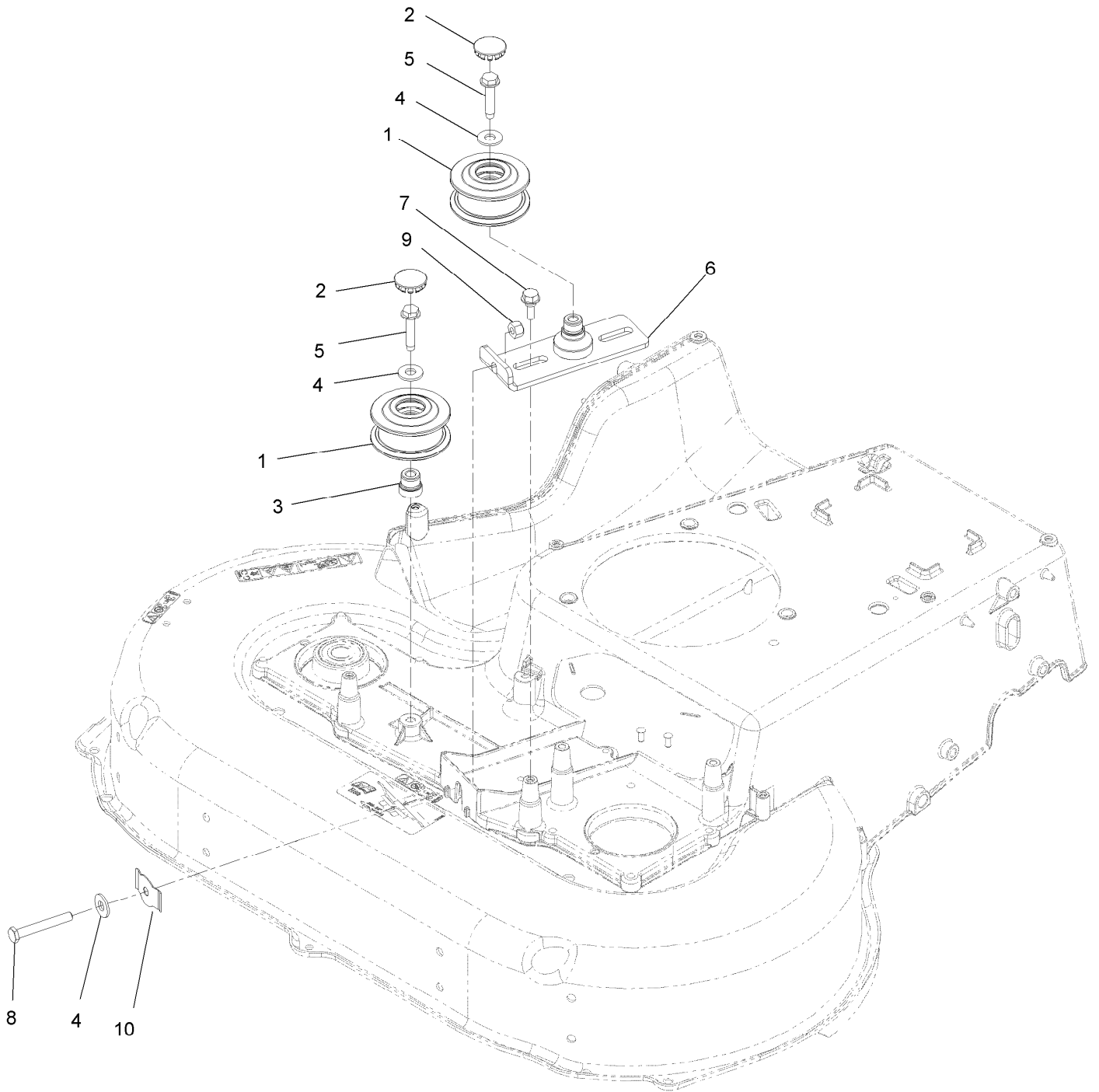

Pulleys and Idler Assembly No. 126-7890 (continued)

<i>Ref.</i>	<i>Part Number</i>	<i>Qty.</i>	<i>Description</i>	<i>Ref.</i>	<i>Part Number</i>	<i>Qty.</i>	<i>Description</i>
1	126-5880	2	Pulley-Idler, Flat	6	126-6453	1	Bracket-Idler
2	126-7151	2	Plug-Button	7	120-7024	2	Screw-Shoulder, HWH
3	131-4504	1	Adapter-Bore	8	9114524	1	Bolt-TAP, HH
4	3256-3	3	Washer-Flat	9	3296-29	1	Nut-Lock, NI
5	32144-57	2	Screw	10	121-2336	1	Spring-Flat

Side Discharge Chute Assembly

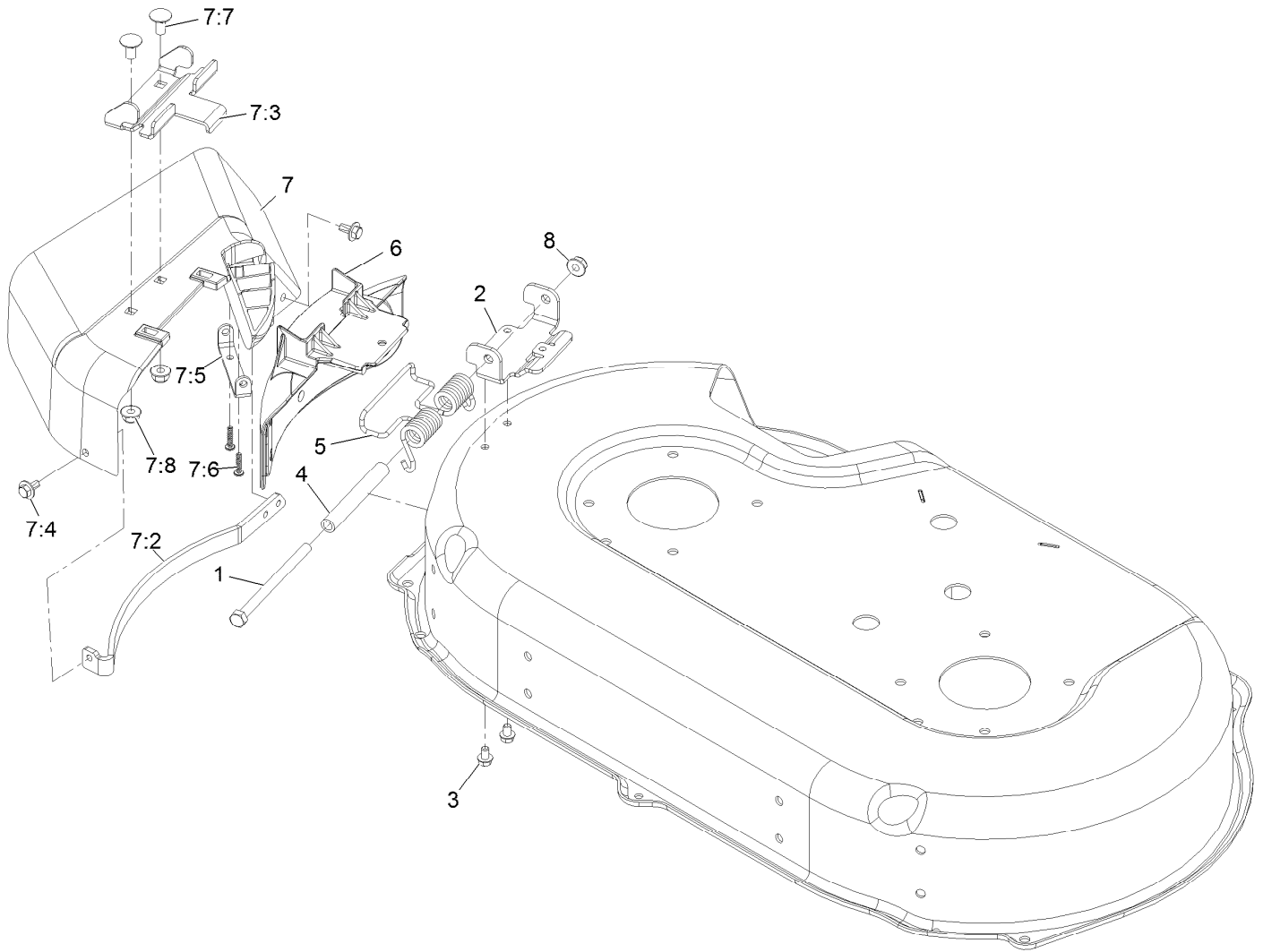

Side Discharge Chute Assembly (continued)

<i>Ref.</i>	<i>Part Number</i>	<i>Qty.</i>	<i>Description</i>	<i>Ref.</i>	<i>Part Number</i>	<i>Qty.</i>	<i>Description</i>
1	322-38	1	Screw-HH 5/16-18 X 4 1/2	7:2	116-9752-03	1	Guard-Chute
2	121-9195	1	Hinge	7:3	121-9196	1	Bracket-Chute
3	99-8445	2	Screw-HWH 1/4-20 X 3/8 Taptite	7:4	46-8560	2	Screw-HHF 1/4-20 X 1/2
4	125-2478	1	Spacer	7:5	112-6416	1	Bracket-Cover
5	121-9193	1	Spring-Torsion	7:6	94-4496	2	Screw-PPH
6	125-5093-01	1	Cover-Discharge	7:7	3230-18	2	Bolt-Carriage 5/16-18 X 5/8
7	116-9754	1	Side Discharge Chute ASM	7:8	104-8300	2	Nut-Nyloc 5/16-18 Flg
				8	104-8300	1	Nut-Nyloc 5/16-18 Flg

Bag Assembly

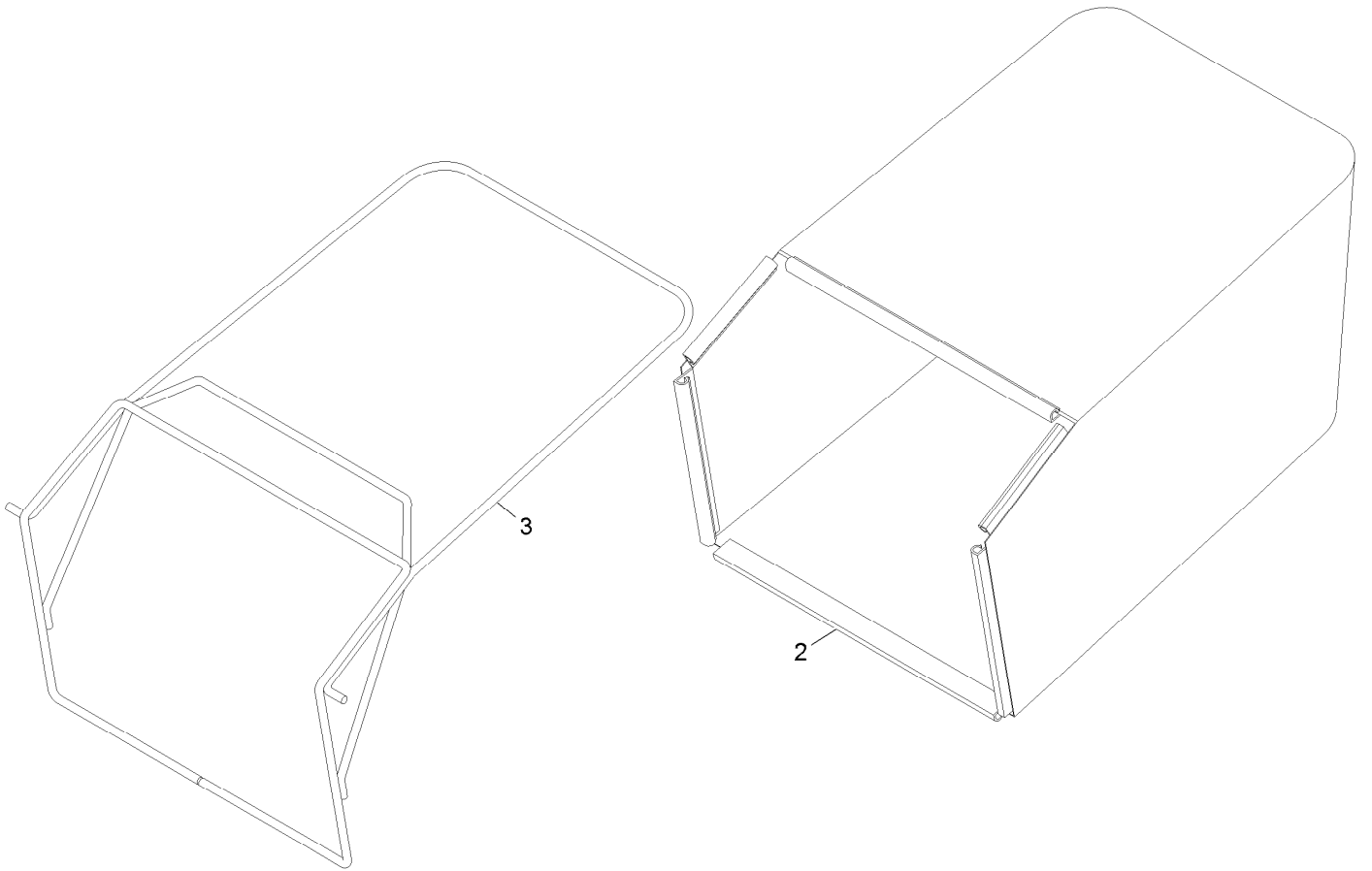

Bag Assembly (continued)

<i>Ref.</i>	<i>Part Number</i>	<i>Qty.</i>	<i>Description</i>
2	116-6350	1	Bag-Grass
3	116-5596-03	1	Frame-Bag

Engine and Fuel Tank Assembly

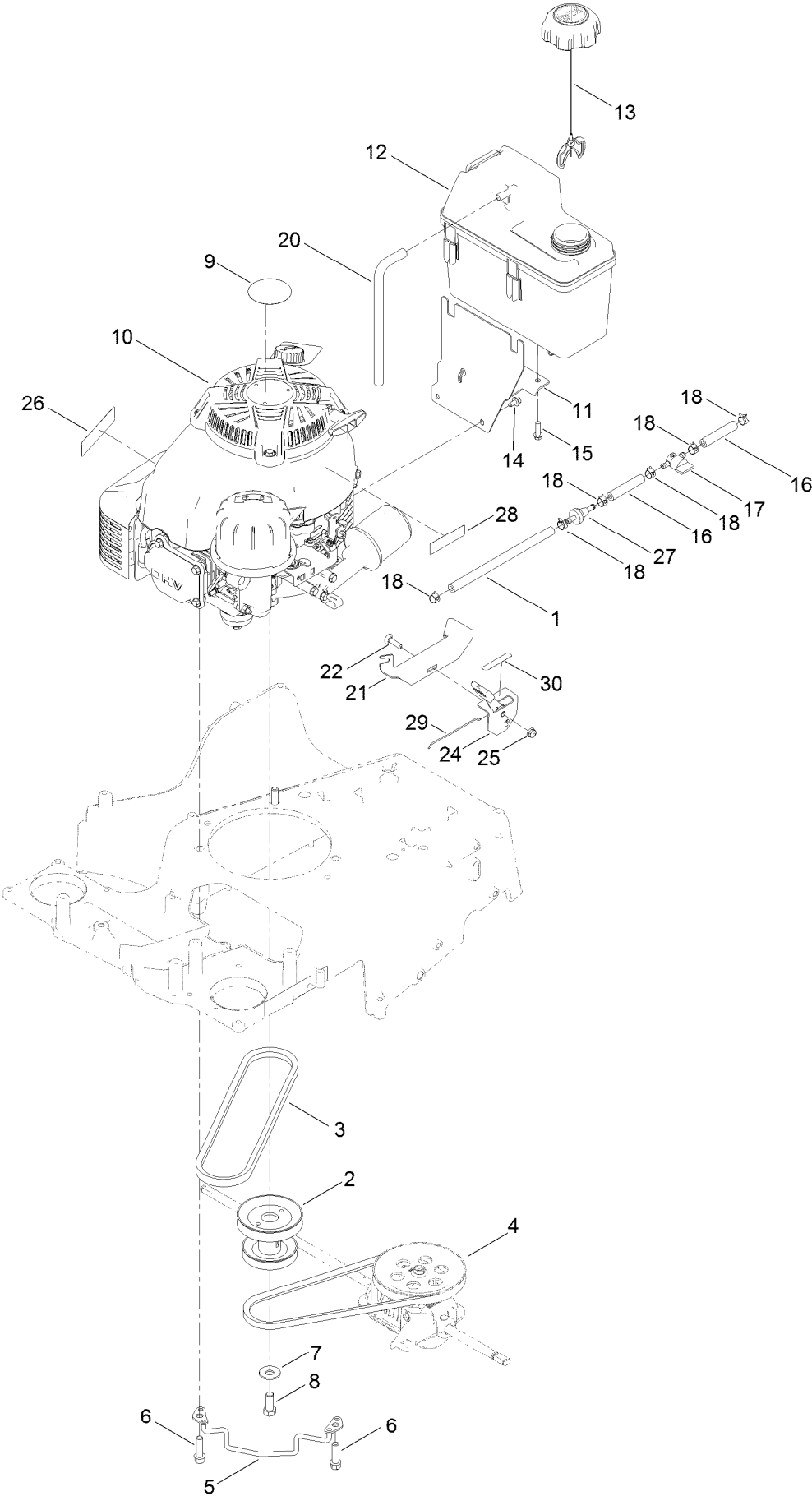

Engine and Fuel Tank Assembly (continued)

<i>Ref.</i>	<i>Part Number</i>	<i>Qty.</i>	<i>Description</i>	<i>Ref.</i>	<i>Part Number</i>	<i>Qty.</i>	<i>Description</i>
1	119-1892	1	Hose-Fuel	15	46-8091	2	Screw-HWH
2	137-9177	1	Pulley-Engine	16	109-0304	2	Hose-Fuel
3	121-5765	1	V-Belt	17	1-603770	1	Valve-Fuel
4	116-7116	1	Belt	18	2412-98	6	Clamp-Hose
5	138-5319	1	Guide-Belt	20	115-0962	1	Hose-Vent, Canister
6	95-1727	3	Screw-Taptite	21	130-6440-03	1	Bracket-Mount, Throttle
7	3290-465	1	Washer-Belleville	22	3229-30	1	Screw-CARR
8	3212-4	1	Screw-HH	24	130-9655	1	Control-Throttle
9	109-6528	1	Decal-Recoil	25	104-7201	1	Nut-HF
10		1	Engine-Kawasaki Fj180V ●■	26	133-8062	1	Decal-Arrestor, Spark
11	115-0954-03	1	Mount-Tank	27	71-9280	1	Filter-Fuel
12	114-0280	1	Tank-Fuel	28	116-9313	1	Decal-Warning, Engine
13	137-4127	1	Cap-Fuel	29	130-9654	1	Wire-Control
14	116-8929	3	Screw-HWH	30	130-9656	1	Decal-Throttle, Choke

● Not serviced separately

■ Obtain parts from www.kawpowerepc.com

Front Bumper and Wheel Assembly

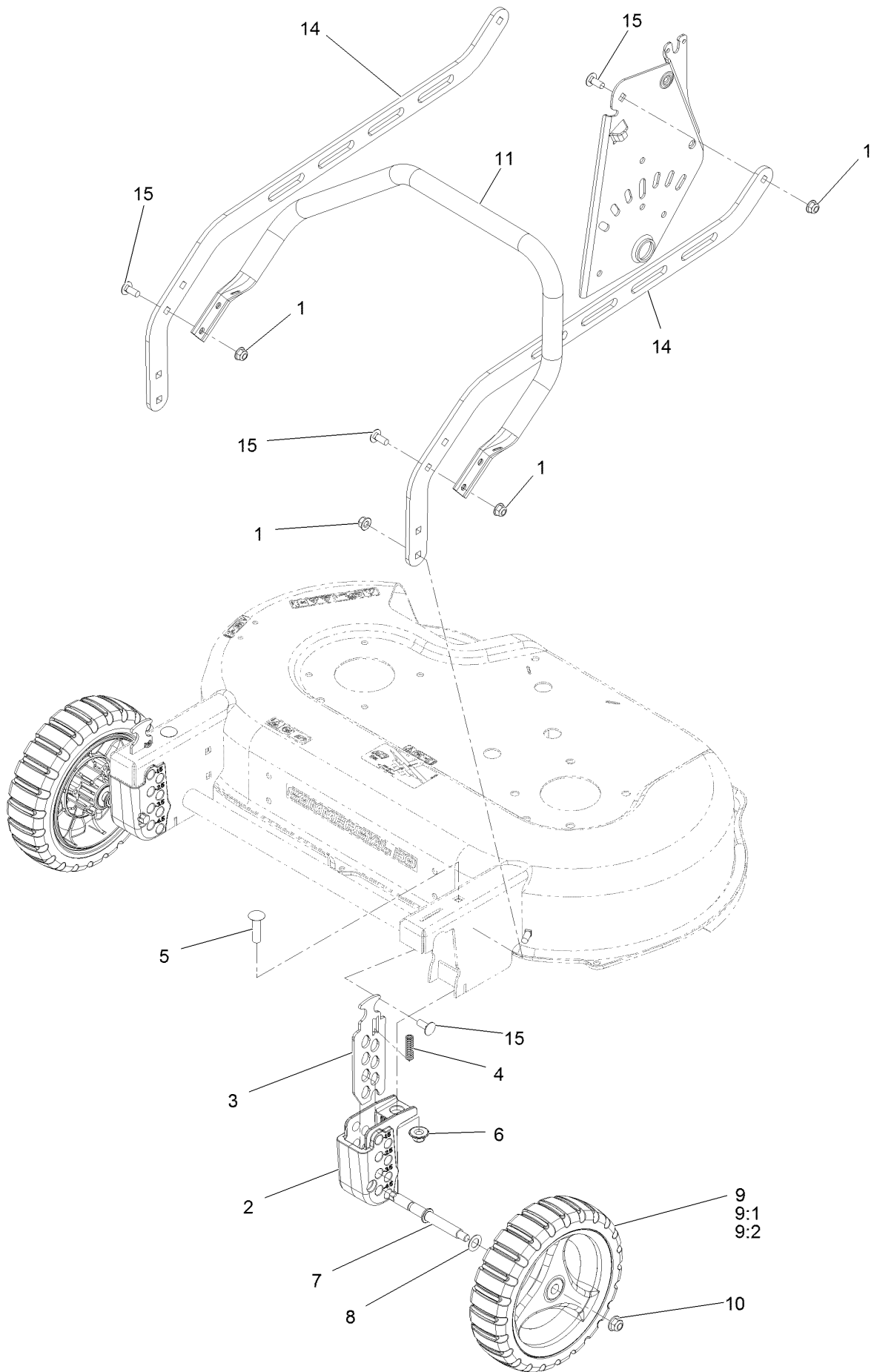

Front Bumper and Wheel Assembly (continued)

<i>Ref.</i>	<i>Part Number</i>	<i>Qty.</i>	<i>Description</i>	<i>Ref.</i>	<i>Part Number</i>	<i>Qty.</i>	<i>Description</i>
1	104-8300	10	Nut-Nyloc 5/16-18 Flg	9	126-7347	2	Wheel ASM, 9" W/Bearings
2	116-6357	2	Block-Front Quadrant	9:1	126-7345	1	Wheel ASM, 9"
3	109-9292	2	Plate, Front Height	9:2	133-2603	2	Bearing-Ball
4	109-7258	2	Spring-Compression	10	104-8301	2	Nut-Nyloc 3/8-16 Flg
5	3231-26	2	Bolt-Carriage 3/8-16 X 1 1/2	11	116-7675-03	1	Guard-Engine
6	109-6658	2	Nut-Nyloc 3/8-16 Flg	14	116-7661-03	2	Brace-RH
7	116-0994	2	Axle-Wheel	15	3230-23	10	Bolt-Carriage 5/16-18 X 3/4 Short Neck
8	36-4780	2	Washer				

Deck and Wheel Assembly

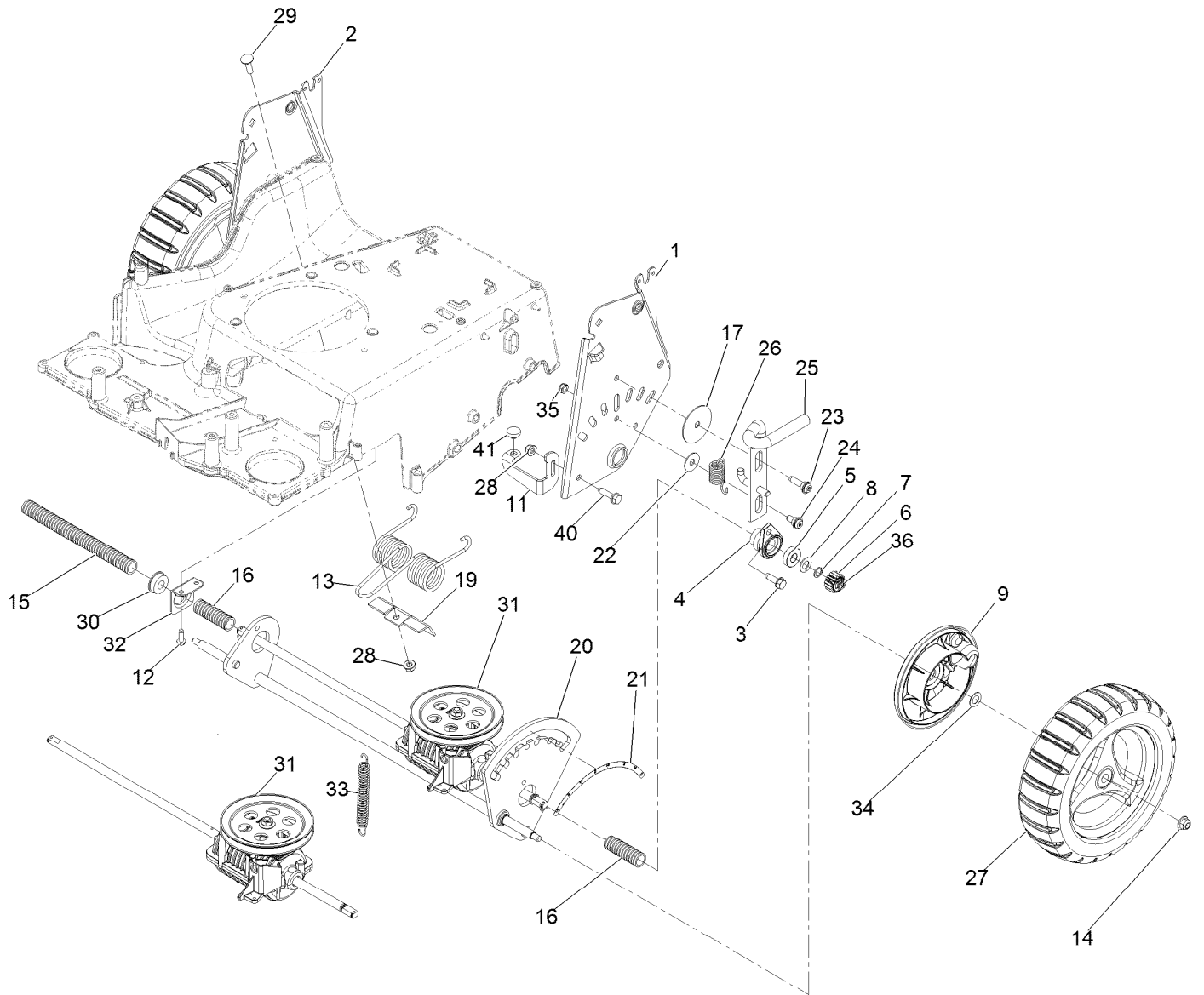

Deck and Wheel Assembly (continued)

<i>Ref.</i>	<i>Part Number</i>	<i>Qty.</i>	<i>Description</i>	<i>Ref.</i>	<i>Part Number</i>	<i>Qty.</i>	<i>Description</i>
1	121-2394-03	1	LH HOC Plate ASM	23	119-2267	1	Screw-Button Head 5/16-18 X 1 Tf
2	121-2395-03	1	RH HOC Plate ASM	24	120-9471	1	Screw-Shoulder Bh 5/16-18 X 1/2 Tf Torx
3	701243	6	Screw-HWH 5/16-18 X 1 Tf	25	120-7090	1	Lock-Height, Adjust
4	136-5929	2	Retainer-Bearing	26	120-9452	1	Spring-Extension
5	133-2603	2	Bearing-Ball	27	126-7346	2	Wheel ASM, 10.5 W/Gear
6	131-5399	2	Gear-Pinion, 15T	28	104-8300	2	Nut-Nyloc 5/16-18 Flg
7	32151-61	1	Ring-Retaining	29	3230-2	1	Bolt-Carriage 5/16-18 X 1
8	110-7191	2	Washer-Thrust	30	104-8699	1	Bearing-Ball
9	126-7818	2	Cover,Gear	31	131-9667	1	Transmission Kit
11	131-5344	1	Bracket-Stop, Adjustable	32	138-3233	1	Mount-Bearing
12	49-2040	2	Screw-HWH 1/4-20 X 3/4 Tf	33	120-7027	1	Spring-Extension
13	121-2368	1	Spring-Torsion	34	36-4780	2	Washer
14	104-8301	2	Nut-Nyloc 3/8-16 Flg	35	3296-47	1	Nut-Nyloc 5/16-18 Thin
15	121-5799	1	Conduit-Convoluted	36	130-2369	2	Pin-Snap
16	121-5800	2	Conduit-Convoluted	40	32144-49	1	Screw-HWH 5/16-18 1 1/4 Tf
17	125-2540	1	Washer-Plain	41	1-513658	1	Bumper
19	121-2397	1	Bracket				
20	131-4516	1	Axle-Rear				
21	116-7127	1	Decal-HOC, Rear				
22	52-2860	1	Washer				

Handle Assembly

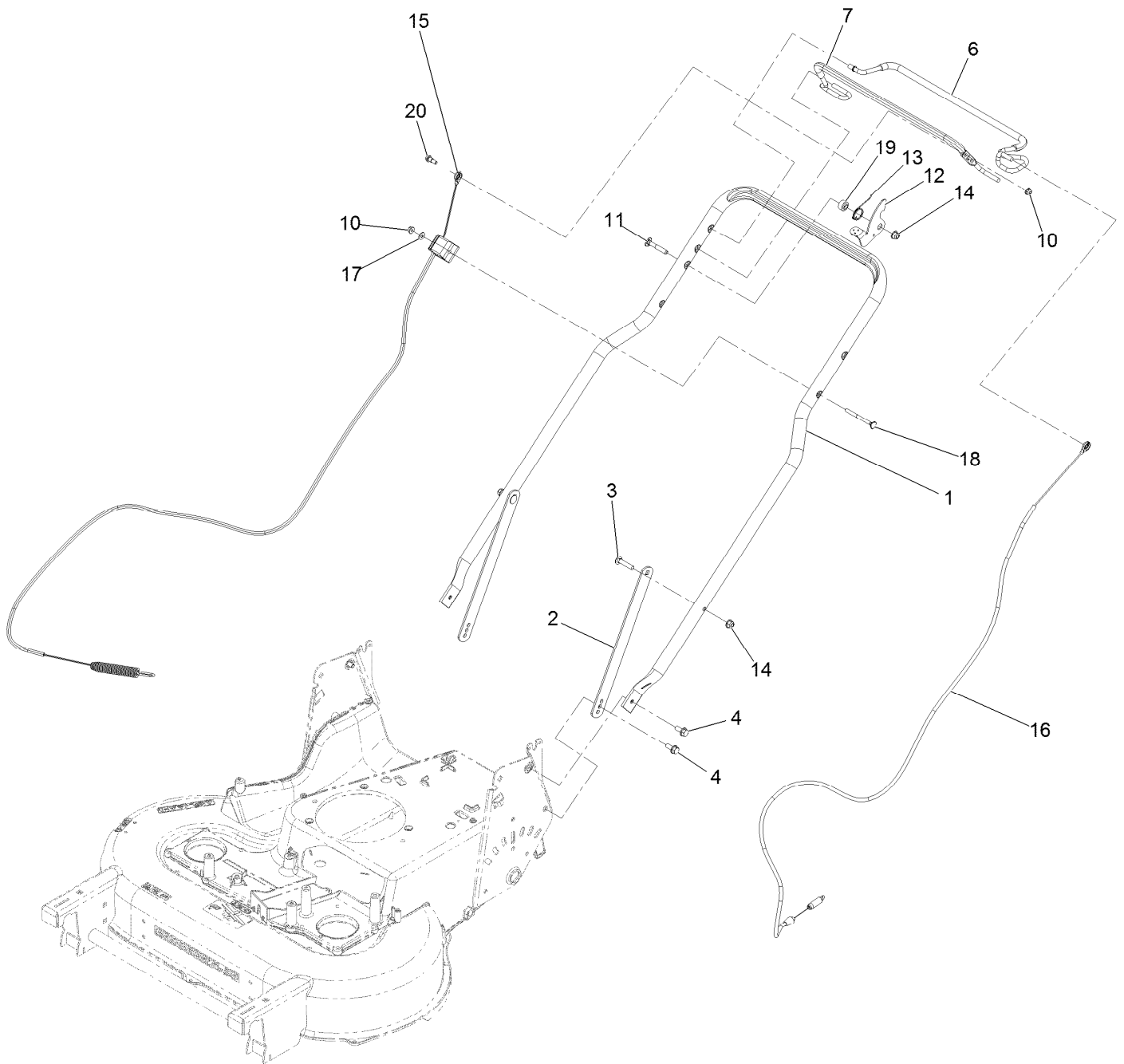

Handle Assembly (continued)

<i>Ref.</i>	<i>Part Number</i>	<i>Qty.</i>	<i>Description</i>	<i>Ref.</i>	<i>Part Number</i>	<i>Qty.</i>	<i>Description</i>
1	137-4767-03	1	Handle	13	109-9318	1	Spring-Lever, BBC
2	116-8208-03	2	Support-Handle	14	104-8300	3	Nut-Nyloc 5/16-18 Flg
3	3230-4	2	Bolt-Carriage 5/16-18 X 1 1/2	15	137-4759	1	Cable-BBC
4	116-7230	4	Screw-HHF	16	137-4758	1	Cable-Traction
6	137-4811	1	Bail-Traction, Coated	17	3256-1	1	Washer-Flat
7	137-4810	1	Bail-BBC, Coated	18	92-2267	1	Screw-Handle
10	104-7201	2	Nut-Nyloc 1/4-20 Flg	19	116-2690	1	Bushing-Stepped
11	112-8876	1	Bolt-Carriage 5/16-18 X 2	20	42-3560	1	Bolt-Shoulder
12	116-2998	1	Lever-BBC	99	614249	3	Tie-Cable ●

● Not illustrated

EXMARK ACCESSORIES AND OPTIONS*

MID-MOUNT RIDING ACCESSORIES AND OPTIONS

CUSTOM RIDE SEAT SUSPENSION SYSTEM	OPERATOR CONTROLLED DISCHARGE
FULL SUSPENSION SEAT	SUN SHADE
DECK LIFT ASSIST KIT	TRASH CONTAINER
HITCH KIT	TURF STRIPER
LIGHT KIT	ULTRA VAC COLLECTION SYSTEM
12V POWER PORT	ULTRA VAC QUICK DISPOSAL SYSTEM
MICRO-MULCH SYSTEM	

OUT-FRONT RIDING ACCESSORIES AND OPTIONS

CUSTOM RIDE SEAT SUSPENSION SYSTEM	SNOW BLADE
DUAL-TAIL WHEEL	SNOWBLOWER
FLOOR PAN EXTENDER	SUN SHADE
HITCH KIT	TRASH CONTAINER
LIGHT KIT	ULTRA VAC COLLECTION SYSTEM
MICRO-MULCH SYSTEM	ULTRA VAC QUICK DISPOSAL SYSTEM
ROLL OVER PROTECTION SYSTEM (ROPS)	WEATHER CAB

WALK-BEHIND ACCESSORIES AND OPTIONS

GRASS CATCHER	TURF STRIPER
MICRO-MULCH SYSTEM	STANDON

*Some accessories and options not available for some models.

Place Model No. and Serial No.
Label Here (Included in the Literature
Pack) or Fill in Below

Model No. _____

Serial No. _____

Date Purchased _____

Engine Model No. and Spec. No. _____

Engine Serial No. (E/No) _____

© 2019 Exmark Mfg. Co., Inc.
2101 Ashland Ave
Beatrice, NE 68310
All Rights Reserved

Part No. 4503-962 Rev. B
(402) 223-6375
Fax (402) 223-5489
Printed in the USA.

