



# LAZER Z<sup>®</sup> X-SERIES

Model No. LZX740EKC526W0—Serial No. 402082300 and Up

Picture below may not reflect actual product.



# Parts Manual

Part No. 4503-733 Rev. A

# Ordering Replacement Parts

To order replacement parts, please supply the part number, the quantity, and the description of each part desired.

## Understanding Reference Numbers

Each identified part in an illustration has a reference number. The reference number for a part also appears in the parts list, along with other information about the part.

This catalog uses two special reference number formats, one to indicate parts in a service assembly and another to indicate the quantity of a given part in an illustration.

## Service Assembly Reference Numbers

Parts in service assemblies have reference numbers in the form a:b. The a represents the reference number of the entire service assembly and the b represents a sequential number unique to each part within the service assembly.

For example, a wheel assembly might be identified by reference number 6, the tire by 6:1, the valve by 6:2, and the wheel by 6:3. When you order the assembly identified by reference number 6, you receive all parts identified by reference numbers 6:1, 6:2, and 6:3. However, you may also order any part individually. Reference numbers of this type appear in illustration and in parts lists.

## Reference Numbers Indicating Quantity

In an illustration, if a reference number indicates more than one part, the reference number has the form nX y. The n represents the quantity of the part, the X is the multiplication symbol, and the y represents the reference number.

For example, in an illustration, the reference number 2X 37 means that two of the parts identified by reference number 37 are indicated.

# Touch Up Paint

Exmark black touch up spray paint – gloss black.

Exmark red touch up paint (spray paint – P/N 1-850337 - .6 oz liquid bottle – P/N 103-9140).



If your Exmark dealer does not have the Exmark part in stock, Exmark will get the parts to the dealer the next business day or the part will be FREE Guaranteed!! (Some restrictions apply. See your participating Exmark Dealer for details.)

## Contents

|  |    |
|--|----|
| Complete Deck Assembly.....                            | 4  |
| Deck Assembly.....                                     | 6  |
| Deck W/Decals Assembly.....                            | 8  |
| Idler Assembly.....                                    | 10 |
| Cutter Housing Assembly No. 103-9539.....              | 12 |
| Main Frame Assembly.....                               | 14 |
| X-Series Decal.....                                    | 16 |
| Roll-Over Protection System.....                       | 18 |
| Roll-Over Protection System Assembly No. 116-0230..... | 20 |
| Front Caster and Fork Assembly.....                    | 22 |
| Caster Wheel and Fork Assembly.....                    | 24 |
| Deck Lift Assembly.....                                | 26 |
| Height-of-Cut Assembly No. 109-7438.....               | 28 |
| Controls Assembly.....                                 | 30 |
| Motion Control Assembly.....                           | 32 |
| Rear Wheel Assembly.....                               | 34 |
| Park Brake Assembly.....                               | 36 |
| Seat Assembly.....                                     | 38 |
| Seat Assembly (cont.).....                             | 40 |
| Fuel Assembly.....                                     | 42 |
| Fuel Tank Assembly.....                                | 44 |
| Engine Assembly.....                                   | 46 |
| Hydraulic Assembly.....                                | 48 |
| Pump Idler Assembly No. 116-1255.....                  | 50 |
| LH Hydro Assembly No. 126-1321.....                    | 52 |
| RH Hydro Assembly No. 126-1322.....                    | 54 |
| Electrial Assembly.....                                | 56 |
| Wire Harness Assembly No. 135-2305.....                | 58 |

# Complete Deck Assembly

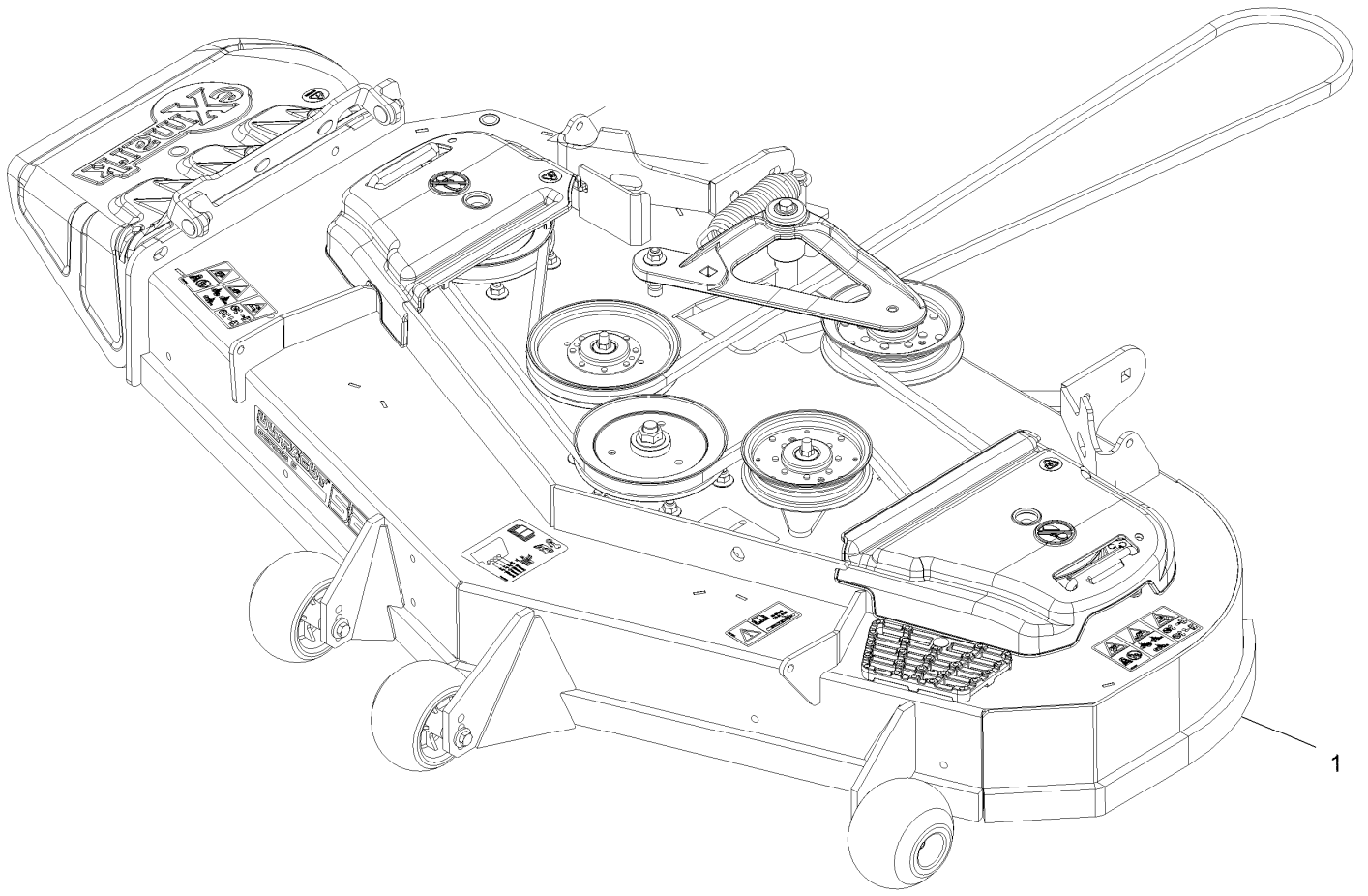

# Complete Deck Assembly (continued)

| <i>Ref.</i> | <i>Part Number</i> | <i>Qty.</i> | <i>Description</i>    |
|-------------|--------------------|-------------|-----------------------|
| 1           | 109-9645           | 1           | ASM,Deck Complete 526 |

# Deck Assembly

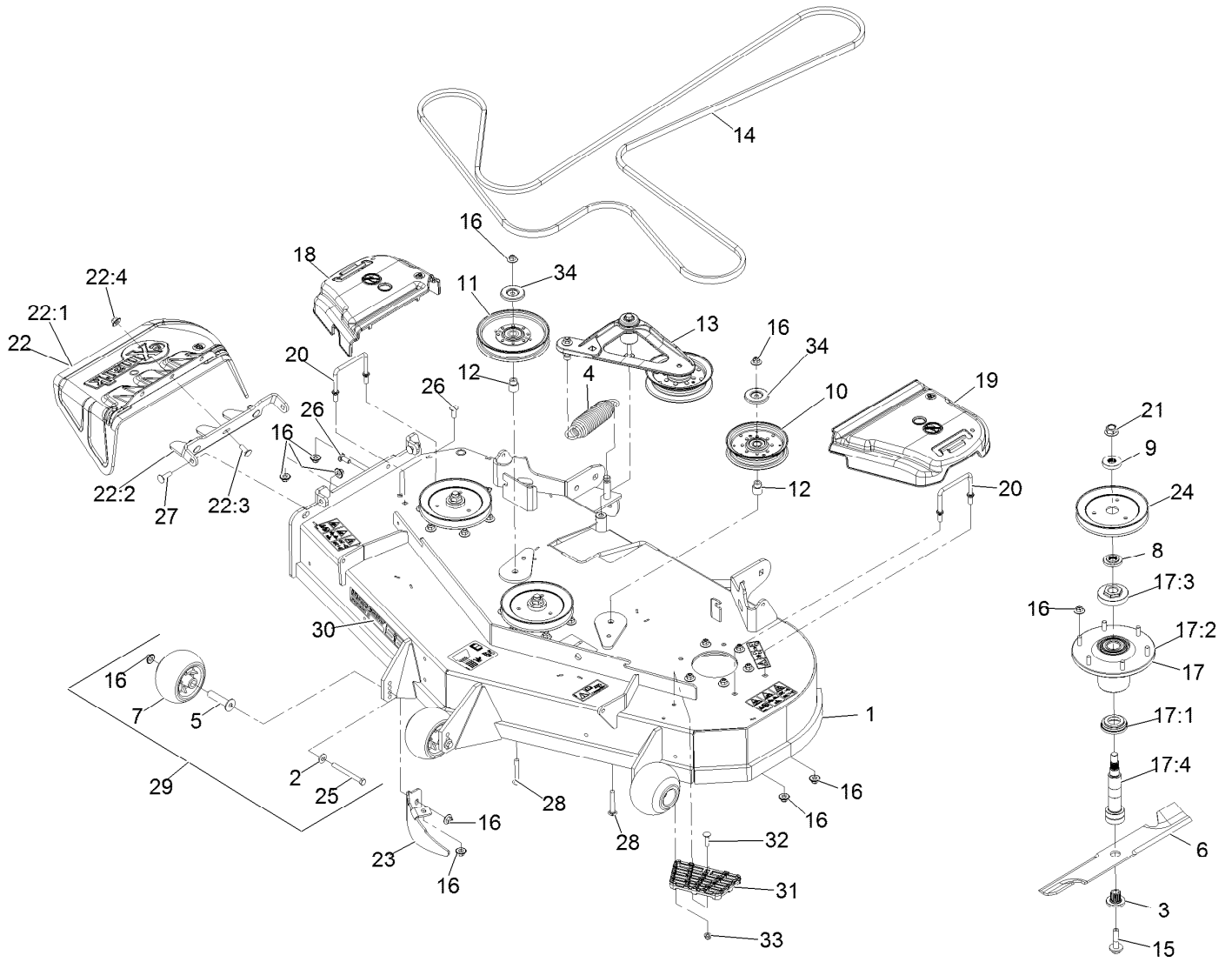

## Deck Assembly (continued)

| <i>Ref.</i> | <i>Part Number</i> | <i>Qty.</i> | <i>Description</i>        | <i>Ref.</i> | <i>Part Number</i> | <i>Qty.</i> | <i>Description</i>               |
|-------------|--------------------|-------------|---------------------------|-------------|--------------------|-------------|----------------------------------|
| 1           | 109-9149           | 1           | ASM,Deck W/ Decals 52     | 18          | 109-6935           | 1           | Cover-Belt, RH                   |
| 2           | 98-5975            | 3           | Washer-Spring Disc 3/8    | 19          | 109-6936           | 1           | Cover-Belt, LH                   |
| 3           | 103-3037           | 3           | Bushing, Splined          | 20          | 109-6982           | 2           | Wireform-Cover                   |
| 4           | 116-6317           | 1           | Spring-Extension          | 21          | 109-7033           | 3           | Nut-Flange 5/8-18<br>Centerlock  |
| 5           | 116-8131           | 3           | Axle, Roller              | 22          | 109-7188           | 1           | ASM,Discharge Chute              |
| 6           | 103-6382           | 3           | Blade, Solid ●            | 22:1        | 109-2738           | 1           | Chute, Discharge                 |
| 6           | 103-6387           | 3           | Blade, Low Lift ●         | 22:2        | 109-8675-01        | 1           | Bracket,Discharge Chute          |
| 6           | 103-6392           | 3           | Blade, Mulching ▲         | 22:3        | 3231-22            | 3           | Bolt-Carriage 3/8-16 X 1         |
| 6           | 103-6402           | 3           | Blade-Notched             | 22:4        | 109-6658           | 3           | Nut-Nyloc 3/8-16 Flg             |
| 6           | 116-5175           | 3           | Blade-Extreme 2, 18.00" ● | 23          | 116-5814-01        | 1           | Baffle-Dogleg, Lz-Vt52           |
| 7           | 103-8415           | 3           | Roller-Anti-Scalp         | 24          | 116-0185           | 3           | Sheave,Blade Drive               |
| 8           | 103-9522           | 3           | Spacer, Splined Stepped   | 25          | 116-9362           | 3           | Screw-HH 3/8-16 X 3 3/4<br>GR 8  |
| 9           | 103-9523           | 3           | Spacer, Splined           | 26          | 3231-22            | 2           | Bolt-Carriage 3/8-16 X 1         |
| 10          | 126-9187           | 1           | Pulley-Idler, Flat        | 27          | 3231-28            | 2           | Bolt-Carriage 3/8-16 X 1 1/4     |
| 11          | 126-7685           | 1           | Idler-Pulley              | 28          | 3231-44            | 2           | Bolt-Carriage 3/8-16 X 2 1/2     |
| 12          | 1-633456           | 2           | Bushing, Idler            | 29          | 116-9981           | 3           | Kit, Anti-Scalp Roller           |
| 13          | 116-3755           | 1           | Deck Idler ASM            | 30          | 126-6591           | 1           | Decal, 526                       |
| 14          | 109-4994           | 1           | Belt,V-B X 186.00"        | 31          | 126-4781-03        | 1           | Step-Deck                        |
| 15          | 109-9220           | 3           | Screw-Sems 1/2-20 X 2.19  | 32          | 3230-3             | 1           | Bolt-Carriage 5/16-18 X 1<br>1/4 |
| 16          | 109-6658           | 31          | Nut-Nyloc 3/8-16 Flg      | 33          | 104-8300           | 1           | Nut-Nyloc 5/16-18 Flg            |
| 17          | 109-6917           | 3           | ASM,Spindle Housing       | 34          | 126-8043           | 2           | Shield-Dust                      |
| 17:1        | 103-9504           | 1           | Guard, Bottom             |             |                    |             |                                  |
| 17:2        | 103-9539           | 1           | Asm, Cutter Housing       |             |                    |             |                                  |
| 17:3        | 109-0916           | 1           | Nut, Spindle 7/8-14 ■     |             |                    |             |                                  |
| 17:4        | 109-6881           | 1           | Spindle,Double Spline ◆   |             |                    |             |                                  |

● Optional Equipment

■ Torque to 160-185 ft-lb

▲ Requires installation of mulch kit for proper mulching. See your Exmark dealer for details.

◆ Apply Mobil HTS grease (P/N 103-5217 1.5 oz packet) (or a food-grade anti-seize). See operator s manual for locations.

# Deck W/Decals Assembly





## Deck W/Decals Assembly (continued)

| <i>Ref.</i> | <i>Part Number</i> | <i>Qty.</i> | <i>Description</i>             | <i>Ref.</i> | <i>Part Number</i> | <i>Qty.</i> | <i>Description</i>               |
|-------------|--------------------|-------------|--------------------------------|-------------|--------------------|-------------|----------------------------------|
| 3           | 126-6464           | 2           | Decal-Danger Thrown<br>Objects | 9           | 1-633456           | 2           | Bushing, Idler                   |
| 4           | 109-6036           | 1           | Decal-Roller, Anti-Scalp       | 10          | 3231-44            | 2           | Bolt-Carriage 3/8-16 X 2 1/2     |
| 5           | 112-9028           | 2           | Decal-Cover, Missing           | 11          | 126-4781-03        | 1           | Step-Deck                        |
| 6           | 116-8283           | 1           | Decal-Bolt Torque              | 12          | 3230-3             | 1           | Bolt-Carriage 5/16-18 X 1<br>1/4 |
| 7           | 116-8727           | 1           | Decal-Belt Routing             | 13          | 104-8300           | 1           | Nut-Nyloc 5/16-18 Flg            |
| 8           | 109-6658           | 2           | Nut-Nyloc 3/8-16 Flg           |             |                    |             |                                  |

# Idler Assembly



## Idler Assembly (continued)

| <i>Ref.</i> | <i>Part Number</i> | <i>Qty.</i> | <i>Description</i> | <i>Ref.</i> | <i>Part Number</i> | <i>Qty.</i> | <i>Description</i> |
|-------------|--------------------|-------------|--------------------|-------------|--------------------|-------------|--------------------|
| 1           | 43-0940            | 1           | Spacer             | 9           | 126-0423           | 1           | Pin-Spring, Anchor |
| 2           | 103-2916           | 1           | Guard-Top          | 10          | 109-6658           | 2           | Nut-Flange, NI     |
| 3           | 103-3504           | 2           | Bearing-Spherical  | 11          | 109-7409           | 1           | Screw-Shoulder, HH |
| 4           | 103-3505           | 1           | Seal-Lip, Double   | 12          | 323-8              | 1           | Screw-HH           |
| 5           | 103-3506           | 1           | Seal-Lip, Single   | 13          | 32120-10           | 2           | Ring-Snap          |
| 6           | 126-9196           | 1           | Idler-Pulley, Flat | 14          | 302-19             | 1           | Fitting-Grease     |
| 7           | 106-7159           | 2           | O-Ring             | 15          | 126-9195           | 1           | Shield-Guard, Dust |

# Cutter Housing Assembly No. 103-9539



# Cutter Housing Assembly No. 103-9539 (continued)

| <i>Ref.</i> | <i>Part Number</i> | <i>Qty.</i> | <i>Description</i>     | <i>Ref.</i> | <i>Part Number</i> | <i>Qty.</i> | <i>Description</i>   |
|-------------|--------------------|-------------|------------------------|-------------|--------------------|-------------|----------------------|
| 1           | 92-5581            | 1           | Ring-Retaining         | 4           | 103-9506           | 1           | Spacer, Bearing      |
| 2           | 109-2064           | 1           | Asm, Bearing W/O-Rings | 5           | 109-0764           | 1           | Asm, Housing W/Studs |
| 3           | 103-5895           | 4           | O-Ring                 |             |                    |             |                      |

# Main Frame Assembly

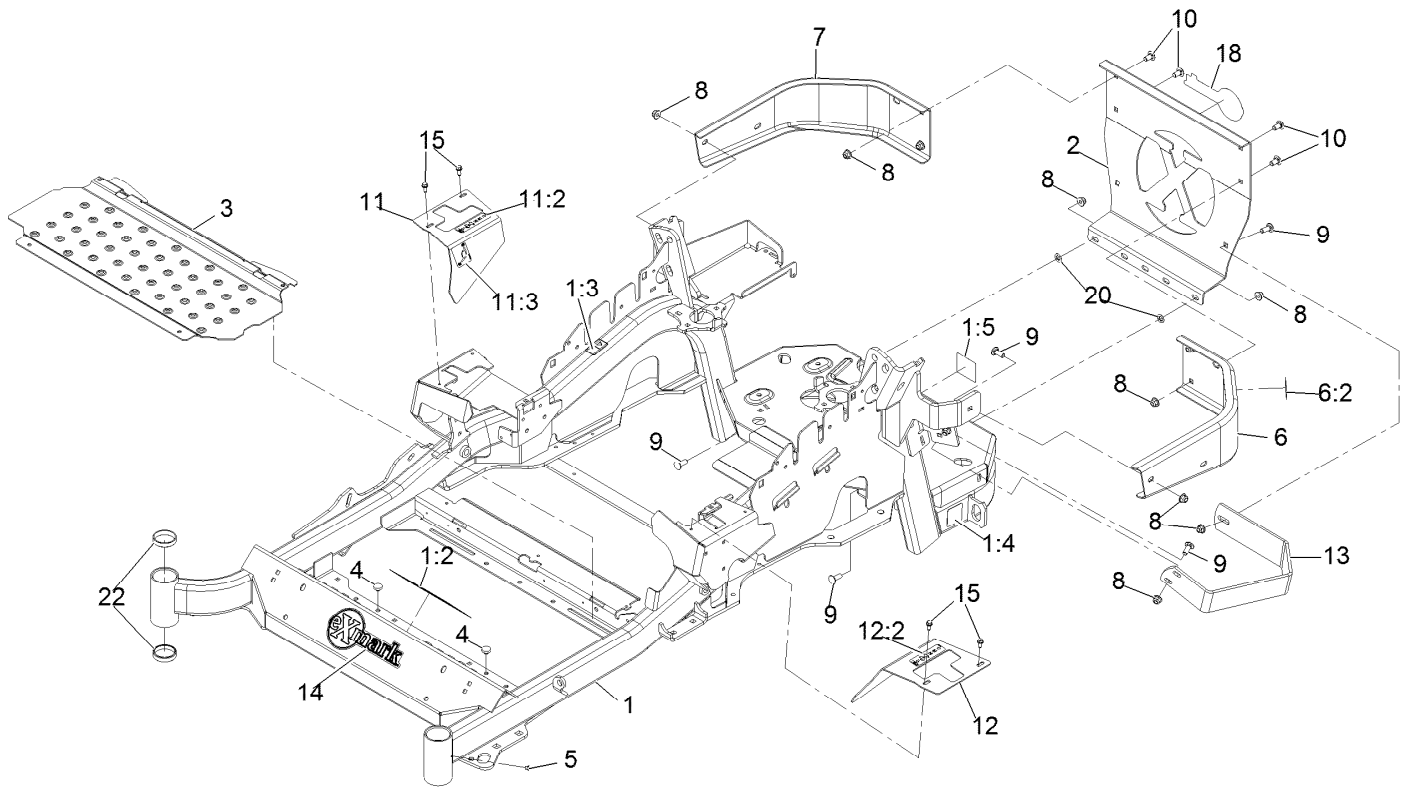

## Main Frame Assembly (continued)

| <i>Ref.</i> | <i>Part Number</i> | <i>Qty.</i> | <i>Description</i>           | <i>Ref.</i> | <i>Part Number</i> | <i>Qty.</i> | <i>Description</i>          |
|-------------|--------------------|-------------|------------------------------|-------------|--------------------|-------------|-----------------------------|
| 1           | 116-5900           | 1           | Mainframe ASM                | 10          | 3231-21            | 4           | Bolt-Carriage 3/8-16 X 3/4  |
| 1:2         | 132-0871           | 1           | Decal-Danger                 | 11          | 116-5899           | 1           | RH Motion Control Cover ASM |
| 1:3         | 106-5517           | 2           | Decal-Warning                | 11:2        | 99-8936            | 1           | Decal-Control, Motion       |
| 1:4         | 106-2655           | 2           | Decal-Hazard, Pinched Finger | 11:3        | 116-5988           | 1           | Decal-Park Brake, CE        |
| 1:5         | 116-4858           | 1           | Decal-Spark Arrester         | 12          | 116-0580           | 1           | LH Motion Control Cover ASM |
| 2           | 109-8863-03        | 1           | Plate,Rear Guard             | 12:2        | 99-8936            | 1           | Decal-Control, Motion       |
| 3           | 116-8898-01        | 1           | Floorpan                     | 13          | 126-2067-03        | 1           | Guard-Muffler               |
| 4           | 1-513658           | 2           | Bumper                       | 14          | 135-2274           | 1           | Decal-Exmark                |
| 5           | 1-811010           | 2           | Plug                         | 15          | 32144-10           | 4           | Screw-HWH 1/4-20 X .62      |
| 6           | 116-0180           | 1           | LH Bumper ASM                | 18          | 126-6965           | 1           | Decal-Exmark Logo           |
| 6:2         | 106-5517           | 1           | Decal-Warning                | 20          | 107-3154           | 2           | Nut-Push 3/8-16             |
| 7           | 116-0057-03        | 1           | Bumper-RH                    | 22          | 1-543508           | 4           | Cup-Bearing Tapered Roller  |
| 8           | 104-8301           | 11          | Nut-Nyloc 3/8-16 Flg         |             |                    |             |                             |
| 9           | 3231-22            | 7           | Bolt-Carriage 3/8-16 X 1     |             |                    |             |                             |

# X-Series Decal

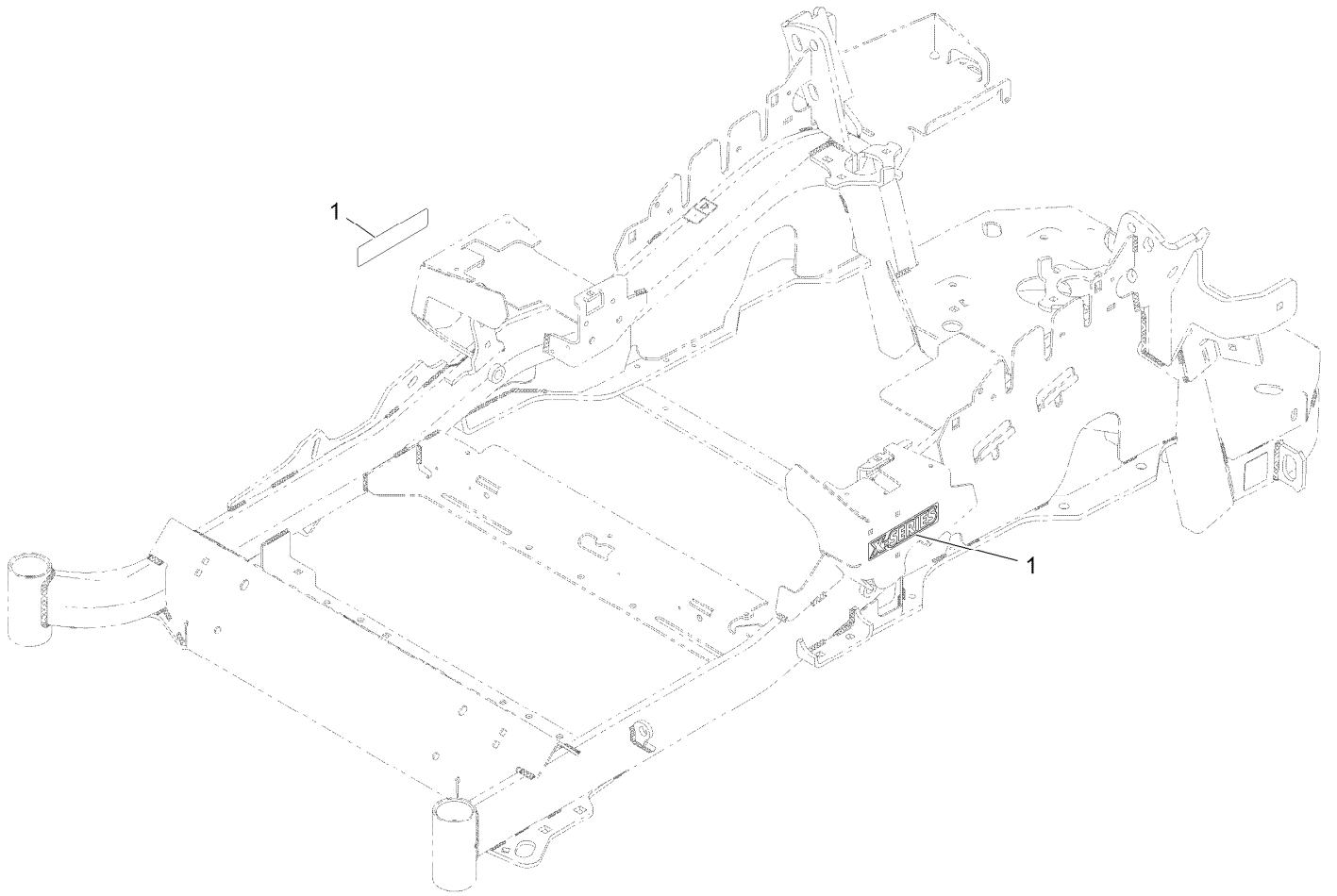



## X-Series Decal (continued)

| <i>Ref.</i> | <i>Part Number</i> | <i>Qty.</i> | <i>Description</i> |
|-------------|--------------------|-------------|--------------------|
| 1           | 126-6573           | 2           | Decal-X-Series     |

# Roll-Over Protection System



# Roll-Over Protection System (continued)

| <i>Ref.</i> | <i>Part Number</i> | <i>Qty.</i> | <i>Description</i>      |
|-------------|--------------------|-------------|-------------------------|
| 1           | 116-0230           | 1           | ASM,ROPS Service Exmark |

# Roll-Over Protection System Assembly No. 116-0230

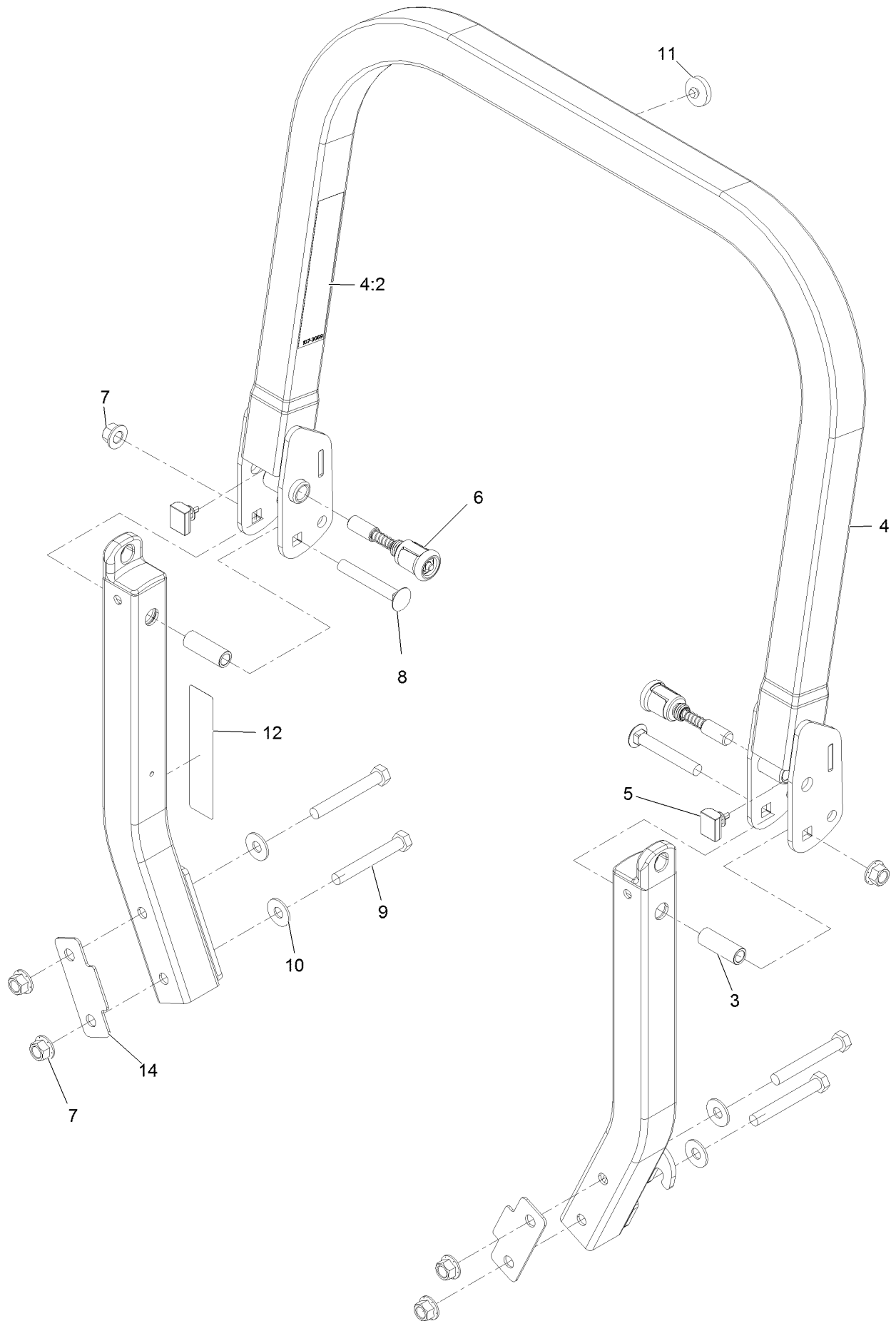

# Roll-Over Protection System Assembly No. 116-0230 (continued)

| <i>Ref.</i> | <i>Part Number</i> | <i>Qty.</i> | <i>Description</i> | <i>Ref.</i> | <i>Part Number</i> | <i>Qty.</i> | <i>Description</i>           |
|-------------|--------------------|-------------|--------------------|-------------|--------------------|-------------|------------------------------|
| 3           | 109-6653           | 2           | Spacer             | 8           | 3233-10            | 2           | Bolt-Carriage 1/2-13 X 3 1/2 |
| 4           | 116-0019           | 1           | Upper ROPS ASM     | 9           | 325-35             | 4           | Screw-HH                     |
| 4:2         | 107-3069           | 1           | Decal-Warning      | 10          | 109-9505           | 4           | Washer, Spring Disc 1/2      |
| 5           | 109-5337           | 2           | Bumper-ROPS        | 11          | 109-9233           | 1           | Bumper-Push-In, Rubber       |
| 6           | 116-0104           | 2           | Pin-Spring         | 12          | 117-0346           | 1           | Decal-Caution, Fuel Vent     |
| 7           | 99-5107            | 6           | Nut-Lock 1/2-13    | 14          | 116-0960           | 2           | Spacer                       |

# Front Caster and Fork Assembly

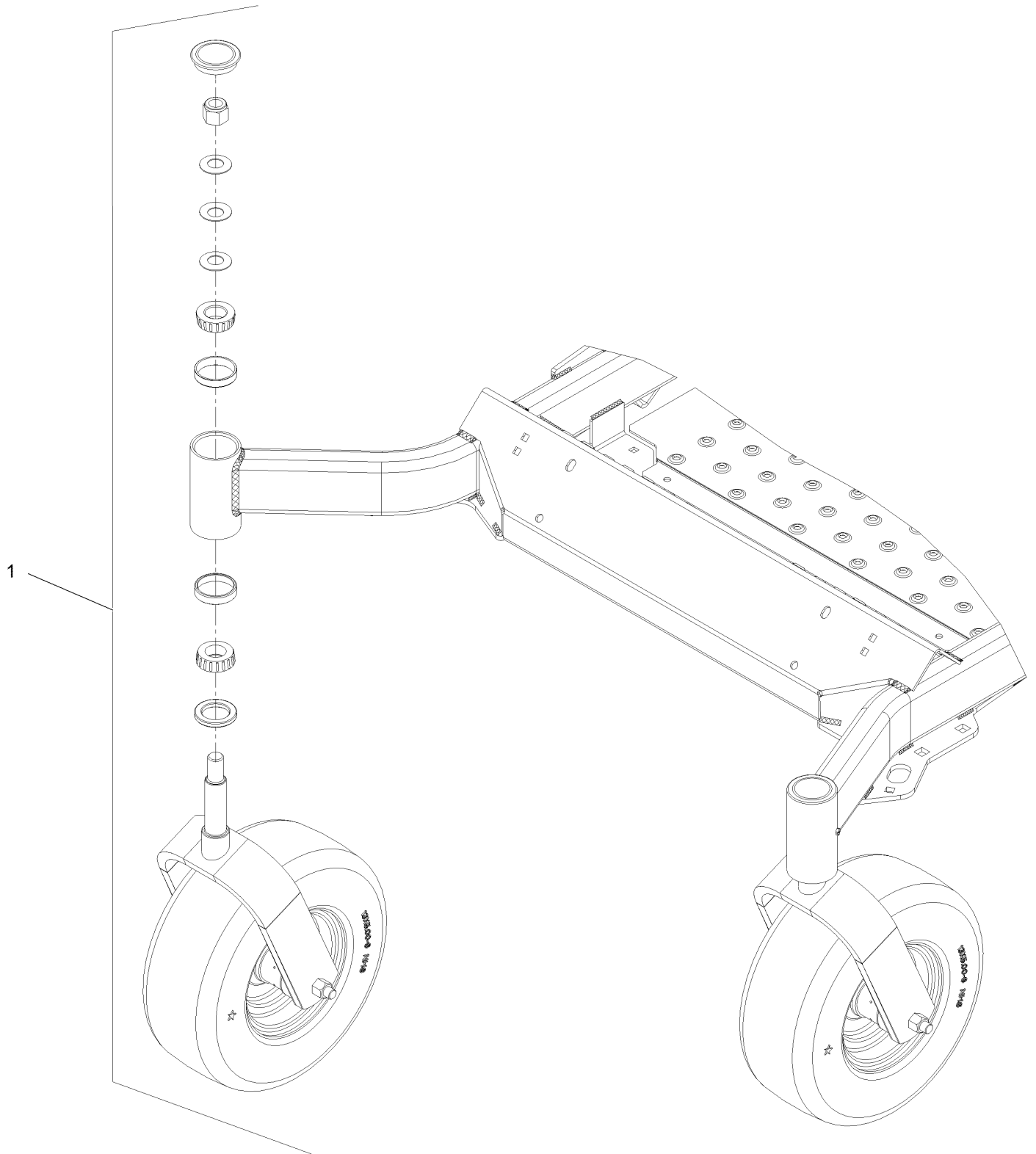

# Front Caster and Fork Assembly (continued)

| <i>Ref.</i> | <i>Part Number</i> | <i>Qty.</i> | <i>Description</i>        |
|-------------|--------------------|-------------|---------------------------|
| 1           |                    | 2           | Front Caster And Fork ASM |
|             |                    |             | ●                         |

● Not serviced separately

# Caster Wheel and Fork Assembly

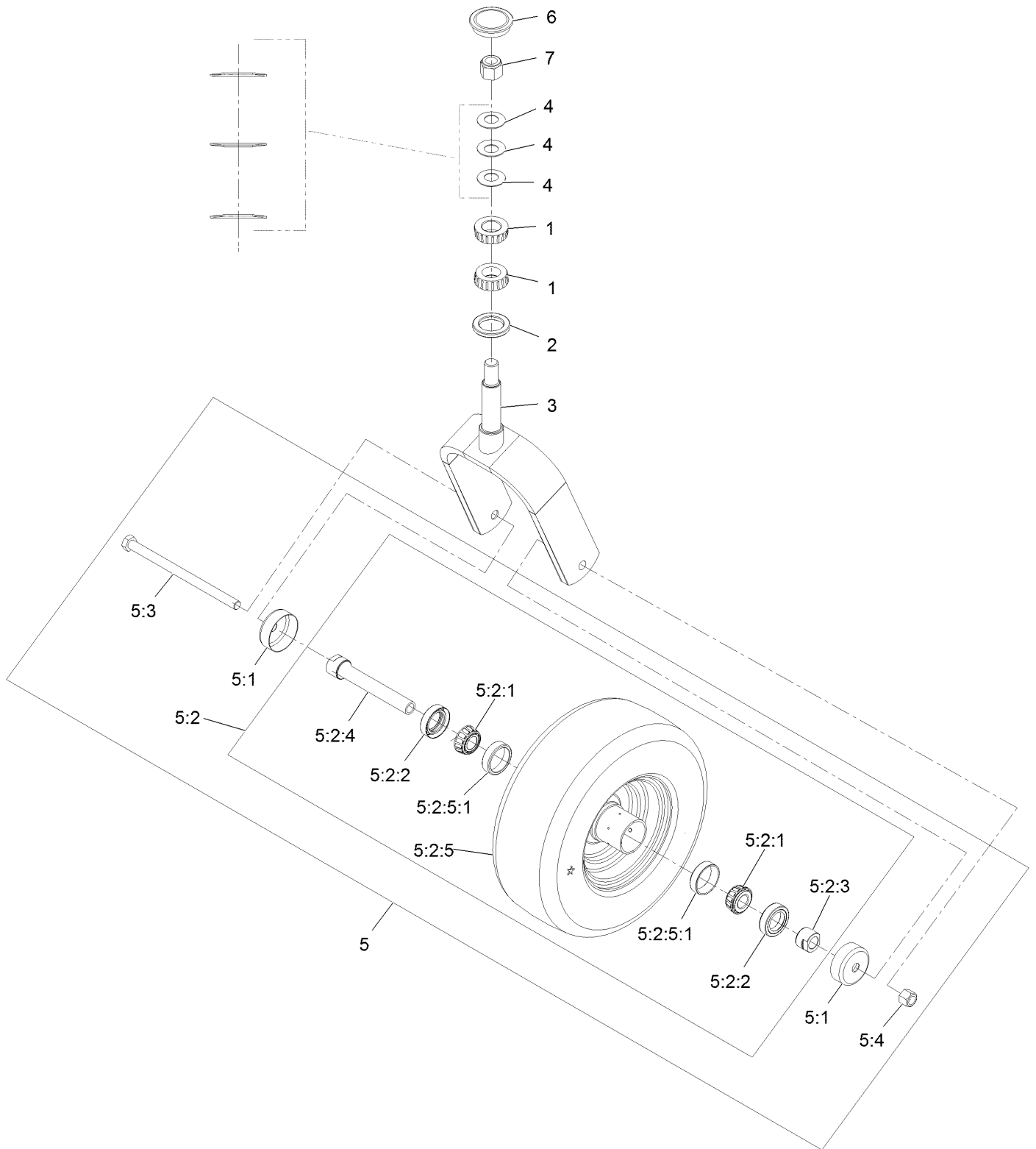



## Caster Wheel and Fork Assembly (continued)

| <i>Ref.</i> | <i>Part Number</i> | <i>Qty.</i> | <i>Description</i>          | <i>Ref.</i> | <i>Part Number</i> | <i>Qty.</i> | <i>Description</i>   |
|-------------|--------------------|-------------|-----------------------------|-------------|--------------------|-------------|----------------------|
| 1           | 1-543509           | 2           | Cone-Bearing Tapered Roller | 5:2:2       | 103-0063           | 2           | Seal-Double Lip      |
| 2           | 116-5647           | 1           | Seal-Grease                 | 5:2:3       | 103-3051           | 1           | Spacer-Nut ■         |
| 3           | 116-6703-01        | 1           | Weld, Fork                  | 5:2:4       | 126-5360           | 1           | Axle-Caster          |
| 4           | 1-633508           | 3           | Washer-Spring Disc          | 5:2:5       |                    | 1           | Wheel And Tire ASM ● |
| 5           | 109-9126           | 1           | Wheel & Tire ASM            | 5:2:5:1     | 1-633584           | 2           | Bearing-Cup          |
| 5:1         | 103-2768           | 2           | Guard-Seal                  | 5:3         | 325-42             | 1           | Screw-HH 1/2-13 X 8  |
| 5:2         |                    | 1           | Wheel And Tire ASM ●        | 5:4         | 3296-23            | 1           | Nut-Nyloc 1/2-13     |
| 5:2:1       | 1-633585           | 2           | Bearing-Cone Tapered Roller | 6           | 103-4882           | 1           | Cap-Grease           |
|             |                    |             |                             | 7           | 3296-51            | 1           | Nut-Nyloc 3/4-10     |

● Not serviced separately

■ Use Pro-Lock, Nut Type (P/N 1-840022, .5ml tube) on threads.

# Deck Lift Assembly

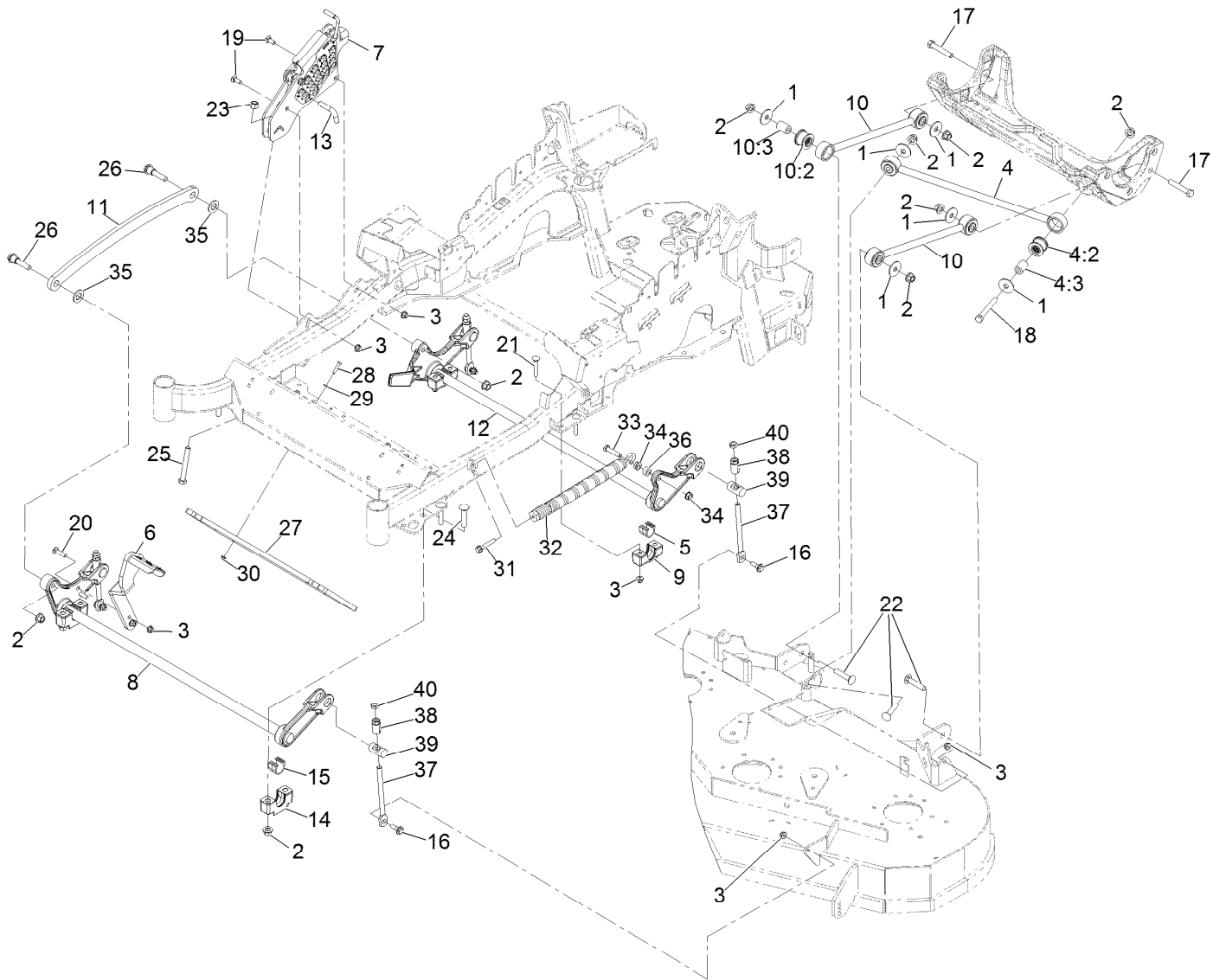

## Deck Lift Assembly (continued)

| <i>Ref.</i> | <i>Part Number</i> | <i>Qty.</i> | <i>Description</i>                   | <i>Ref.</i> | <i>Part Number</i> | <i>Qty.</i> | <i>Description</i>                       |
|-------------|--------------------|-------------|--------------------------------------|-------------|--------------------|-------------|--|
| 1           | 86-1990            | 6           | Washer                               | 18          | 325-17             | 1           | Screw-HH 1/2-13 X 4                      |
| 2           | 99-5107            | 12          | Nut-Lock 1/2-13                      | 19          | 3231-2             | 2           | Bolt-Carriage 3/8-16 X 1                 |
| 3           | 104-8301           | 12          | Nut-Nyloc 3/8-16 Flg                 | 20          | 3231-4             | 2           | Bolt-Carriage 3/8-16 X 1 1/2             |
| 4           | 109-5013           | 1           | Panhard Rod ASM                      | 21          | 3231-7             | 4           | Bolt-Carriage 3/8-16 X 2 1/4             |
| 4:2         | 109-5009           | 2           | Bushing-Suspension,<br>Rubber        | 22          | 3233-34            | 3           | Bolt-Carriage 1/2-13 X 2 1/2             |
| 4:3         | 109-5010           | 2           | Spacer                               | 23          | 3296-23            | 1           | Nut-Nyloc 1/2-13                         |
| 5           | 109-7173           | 2           | Bearing-Cross Shaft, Rear            | 24          | 116-1700           | 4           | Bolt-Carriage 1/2-13 X 2 1/2<br>Spl Neck |
| 6           | 116-1919-01        | 1           | Lever-Foot                           | 25          | 116-0559           | 1           | Bolt-HH 1/2-13 X 4 Tap                   |
| 7           | 109-7438           | 1           | HOC ASM                              | 26          | 116-2022           | 2           | Screw-Hex Flange 1/2-13 X<br>1.90        |
| 8           | 126-2477-03        | 1           | Decklift-Front                       | 27          | 132-5075-01        | 1           | Weight-Toe Board                         |
| 9           | 127-0553           | 2           | Support-Cross Shaft,<br>Bearing Rear | 28          | 321-8              | 4           | Screw-HH 1/4-20 X 1 1/4                  |
| 10          | 109-7952           | 2           | Deck Strut ASM                       | 29          | 3256-22            | 4           | Washer-1/4 SAE                           |
| 10:2        | 109-5009           | 2           | Bushing-Suspension,<br>Rubber        | 30          | 104-7201           | 4           | Nut-Nyloc 1/4-20 Flg                     |
| 10:3        | 109-5010           | 2           | Spacer                               | 31          | 92-7674            | 1           | Screw-Shcs 3/8-16 X 2.212                |
| 11          | 116-0797-03        | 1           | Link-Lift, Deck                      | 32          | 116-0886           | 1           | Spring-Extension                         |
| 12          | 116-2645-03        | 1           | Lift-Deck, Rear                      | 33          | 109-9065           | 1           | Screw-HH 7/16-14 X 2                     |
| 13          | 116-5584           | 1           | Pin-HOC                              | 34          | 32128-37           | 2           | Nut-Whizlock 7/16-14                     |
| 14          | 109-9409           | 2           | Support-Cross Shaft,<br>Bearing      | 35          | 3256-28            | 2           | Washer-3/4 SAE                           |
| 15          | 109-9410           | 2           | Bearing-Cross Shaft, Front           | 36          | 116-2695           | 1           | Spacer                                   |
| 16          | 109-9840           | 4           | Screw-Hex Flange 3/8-16 X<br>.80     | 37          | 109-8007           | 4           | Link-Adjuster, Deck Lift                 |
| 17          | 325-12             | 2           | Screw-HH 1/2-13 X 3                  | 38          | 109-7840           | 4           | Adjuster-Lift, Deck                      |
|             |                    |             |                                      | 39          | 109-8353           | 4           | Trunnion                                 |
|             |                    |             |                                      | 40          | 3218-5             | 4           | Nut-Jam 1/2-13                           |

# Height-of-Cut Assembly No. 109-7438

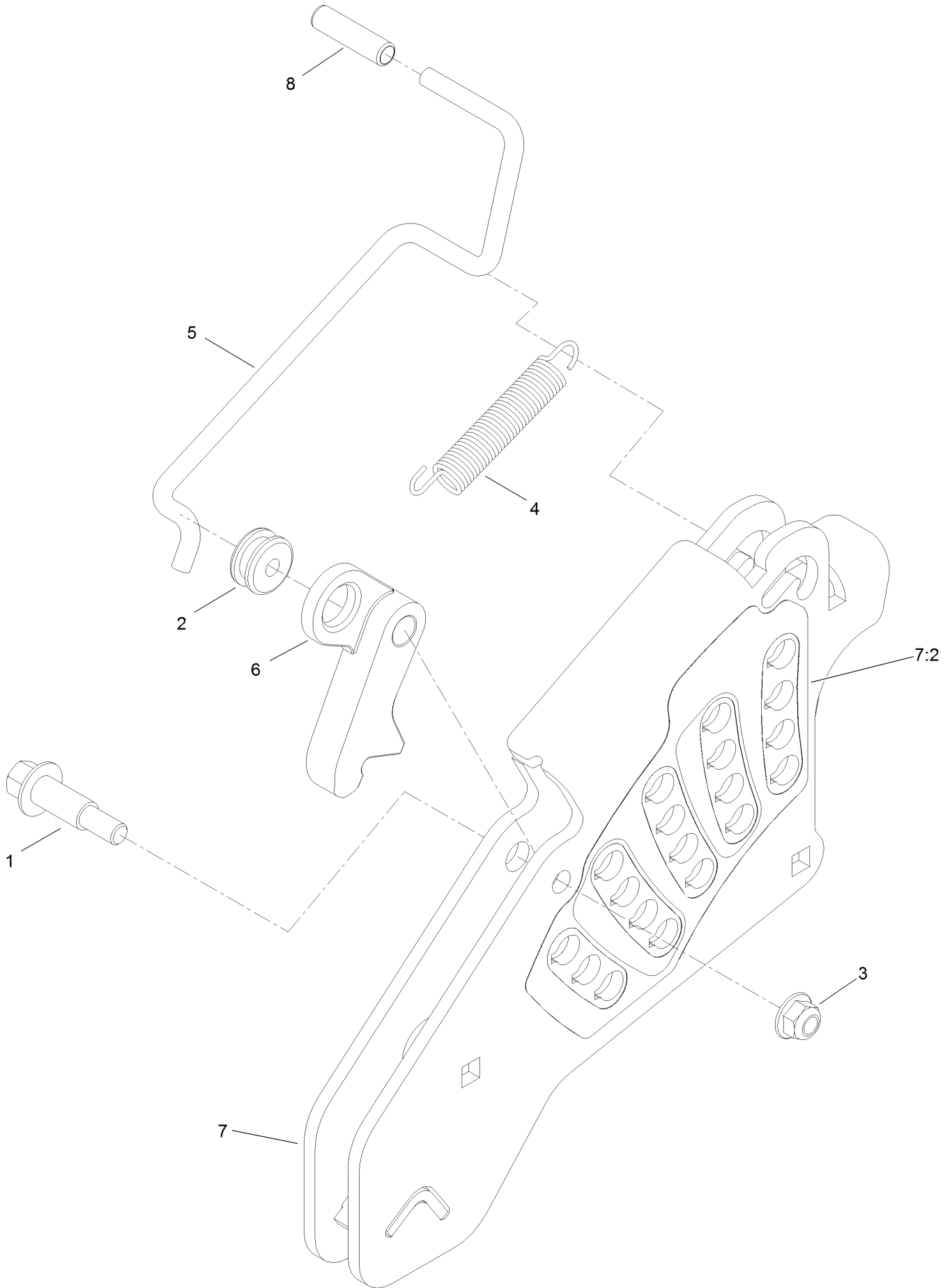

## Height-of-Cut Assembly No. 109-7438 (continued)

| <i>Ref.</i> | <i>Part Number</i> | <i>Qty.</i> | <i>Description</i>  | <i>Ref.</i> | <i>Part Number</i> | <i>Qty.</i> | <i>Description</i>  |
|-------------|--------------------|-------------|---------------------|-------------|--------------------|-------------|---------------------|
| 1           | 62-1330            | 1           | Bolt-Shoulder       | 6           | 116-0118           | 1           | Pawl-Transport, HOC |
| 2           | 109-7130           | 1           | Grommet             | 7           | 109-7335           | 1           | HOC Plate ASM       |
| 3           | 104-8301           | 1           | Nut-HF, NI          | 7:2         | 126-4398           | 1           | Decal-HOC           |
| 4           | 109-7124           | 1           | Spring-Extension    | 8           | 109-8250           | 1           | Grip-Lever          |
| 5           | 109-7128           | 1           | Rod-Lock, Transport |             |                    |             |                     |

# Controls Assembly

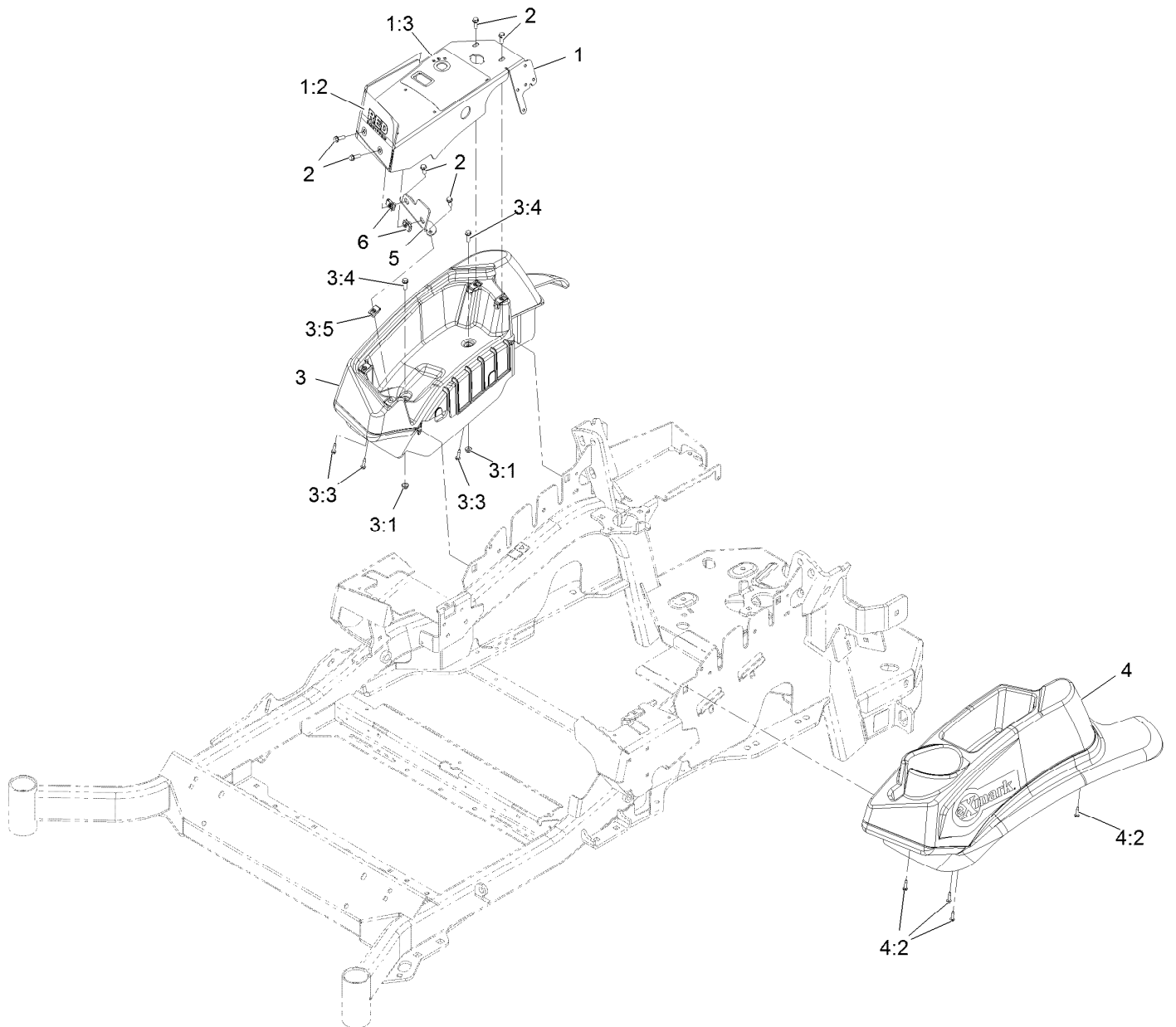

## Controls Assembly (continued)

| <i>Ref.</i> | <i>Part Number</i> | <i>Qty.</i> | <i>Description</i>       | <i>Ref.</i> | <i>Part Number</i> | <i>Qty.</i> | <i>Description</i>    |
|-------------|--------------------|-------------|--------------------------|-------------|--------------------|-------------|-----------------------|
| 1           | 126-7274           | 1           | Cover Panel ASM W/Decals | 3:4         | 32105-15           | 2           | Screw-HWH             |
| 1:2         | 135-0404           | 1           | Decal-Control Panel Red  | 3:5         | 107069             | 4           | Clip                  |
| 1:3         | 126-4479           | 1           | Decal-Console            | 4           | 109-9342           | 1           | Console.LH Narrow ASM |
| 2           | 32105-15           | 6           | Screw-HWH                | 4:2         | 109-9345           | 4           | Screw,Thd Form,HWH    |
| 3           | 109-9341           | 1           | Console,RH Narrow ASM    | 5           | 126-4563-03        | 1           | Bracket-Console       |
| 3:1         | 104-7201           | 2           | Nut-HF                   | 6           | 107069             | 2           | Clip                  |
| 3:3         | 109-9345           | 3           | Screw,Thd Form,HWH       |             |                    |             |                       |

# Motion Control Assembly

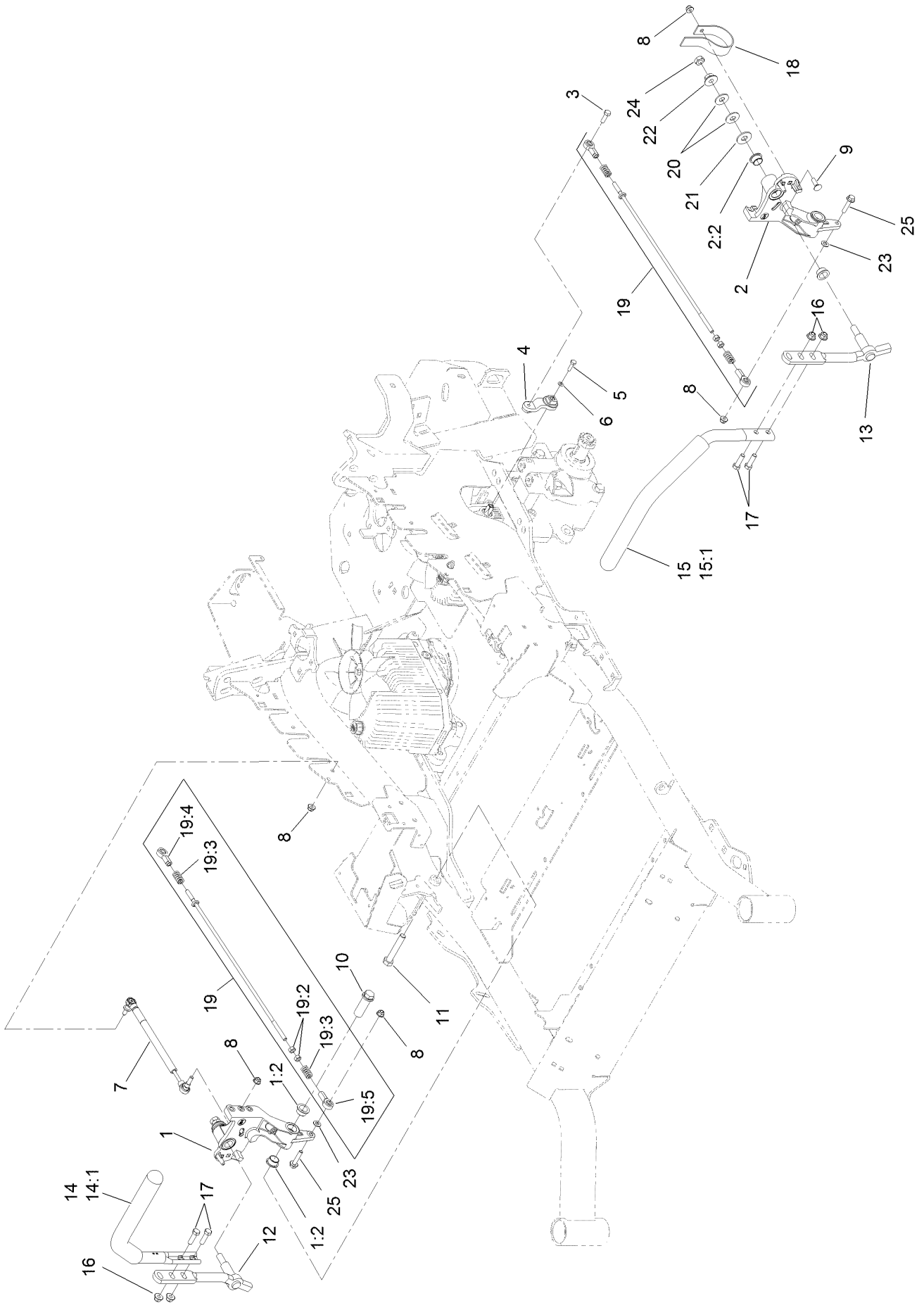



## Motion Control Assembly (continued)

| <i>Ref.</i> | <i>Part Number</i> | <i>Qty.</i> | <i>Description</i>                | <i>Ref.</i> | <i>Part Number</i> | <i>Qty.</i> | <i>Description</i>     |
|-------------|--------------------|-------------|-----------------------------------|-------------|--------------------|-------------|------------------------|
| 1           | 116-0880           | 1           | RH Motion Control And Bushing ASM | 14          | 109-6589           | 1           | RH Steering Handle ASM |
| 1:2         | 109-8054           | 4           | Bushing-Flange                    | 14:1        | 109-5668           | 1           | Grip-Control, Lever    |
| 2           | 116-0881           | 1           | LH Motion Control And Bushing ASM | 15          | 109-6590           | 1           | LH Steering Handle ASM |
| 2:2         | 109-8054           | 4           | Bushing-Flange                    | 15:1        | 109-5668           | 1           | Grip-Control, Lever    |
| 3           | 116-0648           | 2           | Screw-HH, Thread Locking ●        | 16          | 104-8301           | 4           | Nut-HF, NI             |
| 4           | 109-4581           | 2           | Arm-Control, Pump                 | 17          | 323-7              | 4           | Screw-HH               |
| 5           | 9080046            | 2           | Screw-HH ●                        | 18          | 109-5575           | 2           | Spring-Leaf            |
| 6           | 1-303435           | 2           | Washer-Spring                     | 19          | 109-8107           | 2           | Pump Linkage Rear ASM  |
| 7           | 116-0027           | 2           | Damper-Control, Motion            | 19:2        | 3219-2             | 2           | Nut-Hex                |
| 8           | 104-8300           | 8           | Nut-HF, NI                        | 19:3        | 1-323245           | 2           | Spring-Compression     |
| 9           | 3230-2             | 2           | Bolt-CARR                         | 19:4        | 1-633152           | 1           | Balljoint-LH           |
| 10          | 109-5891           | 2           | Hub-Threaded                      | 19:5        | 1-543017           | 1           | Balljoint-RH           |
| 11          | 325-12             | 2           | Screw-HH                          | 20          | 109-9505           | 4           | Washer-Spring          |
| 12          | 116-0039           | 1           | Lever-Control Motion, RH          | 21          | 3256-6             | 2           | Washer-Flat            |
| 13          | 116-0040           | 1           | Lever-Control Motion, LH          | 22          | 32128-56           | 2           | Nut-HF                 |
|             |                    |             |                                   | 23          | 3256-23            | 2           | Washer-Plain           |
|             |                    |             |                                   | 24          | 3218-5             | 2           | Nut-Jam                |
|             |                    |             |                                   | 25          | 115-1794           | 2           | Screw-HHF              |

● Use Pro-Lock, Nut Type (P/N 1-840022, .5ml tube) on threads.

# Rear Wheel Assembly

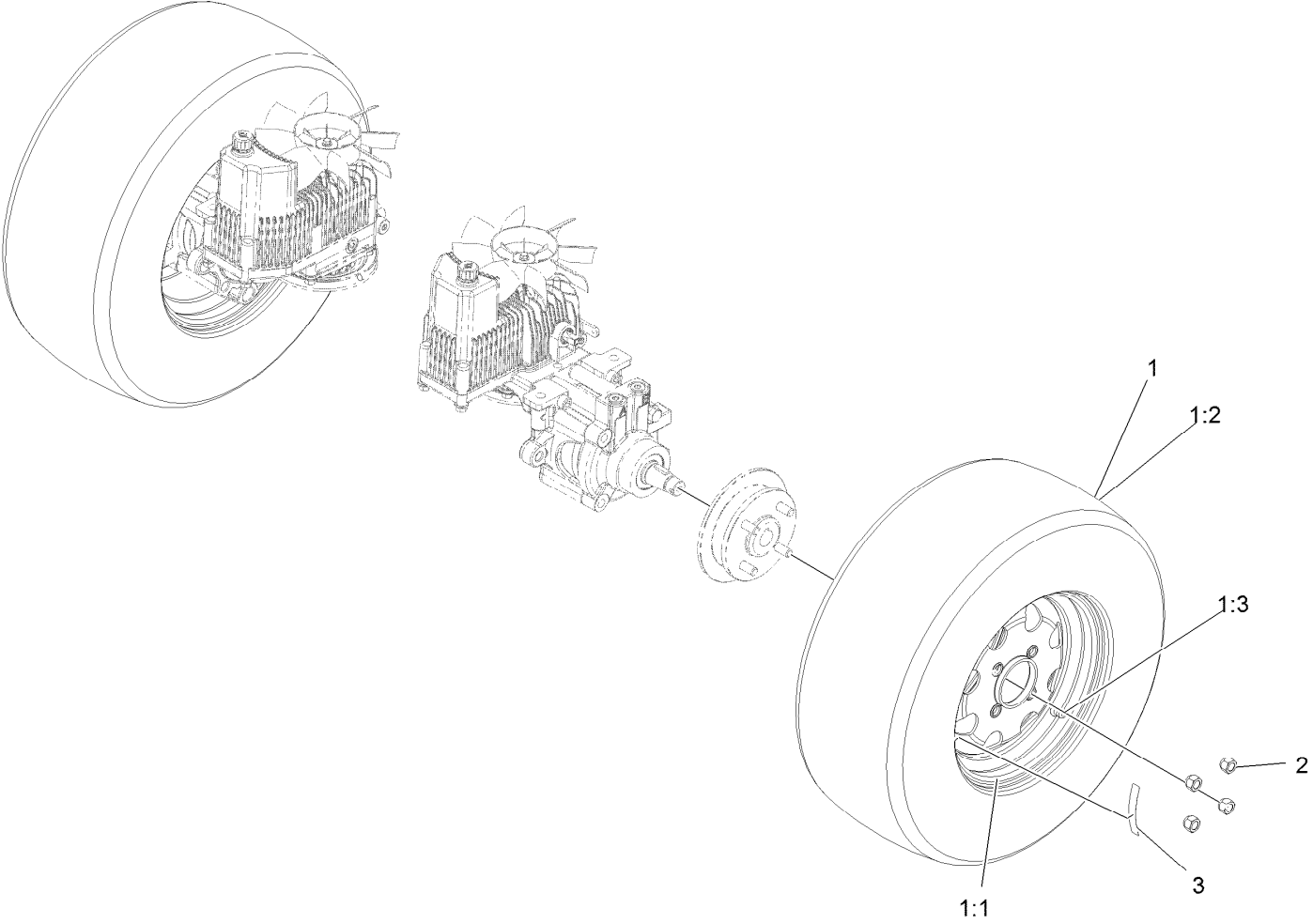

## Rear Wheel Assembly (continued)

| <i>Ref.</i> | <i>Part Number</i> | <i>Qty.</i> | <i>Description</i> | <i>Ref.</i> | <i>Part Number</i> | <i>Qty.</i> | <i>Description</i>             |
|-------------|--------------------|-------------|--------------------|-------------|--------------------|-------------|--------------------------------|
| 1           | 115-3590           | 2           | Wheel And Tire ASM | 2           | 242-50             | 8           | Nut-Lug 1/2-20                 |
| 1:1         | 109-3645           | 1           | Rim ASM            | 3           | 126-2055           | 2           | Decal-Torque, Wheel Hub<br>Lug |
| 1:2         | 1-653160           | 1           | Tire               |             |                    |             |                                |
| 1:3         | 232-27             | 1           | Stem-Valve         |             |                    |             |                                |

# Park Brake Assembly

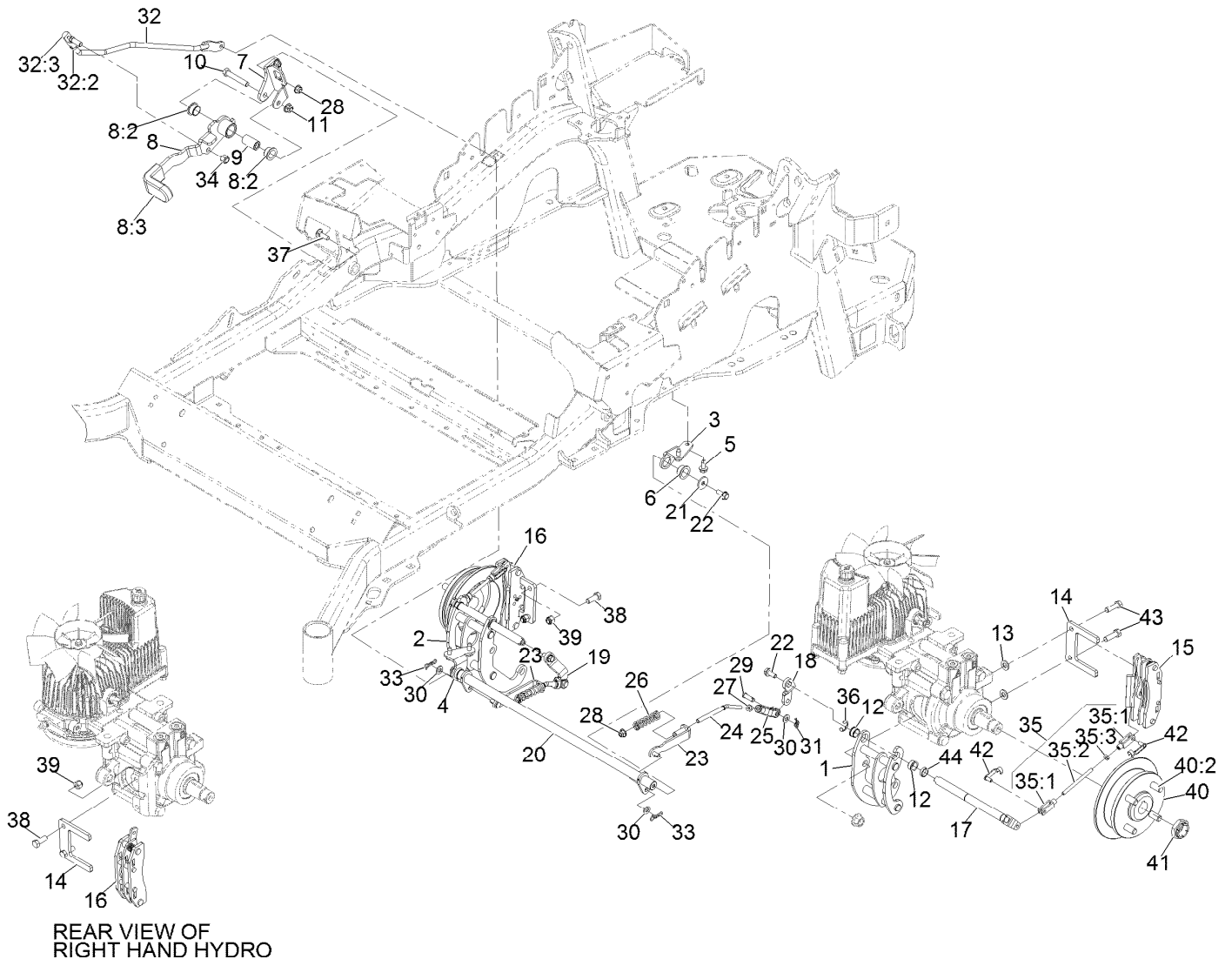

## Park Brake Assembly (continued)

| <i>Ref.</i> | <i>Part Number</i> | <i>Qty.</i> | <i>Description</i>            | <i>Ref.</i> | <i>Part Number</i> | <i>Qty.</i> | <i>Description</i>                    |
|-------------|--------------------|-------------|-------------------------------|-------------|--------------------|-------------|---------------------------------------|
| 1           | 126-4248           | 1           | Mount-Bellcrank, LH           | 26          | 116-9085           | 2           | Spring-Compression                    |
| 2           | 126-4249           | 1           | Mount-Bellcrank, RH           | 27          | 3220-2             | 2           | Nut-Jam 5/16-24                       |
| 3           | 116-9681           | 1           | Mount-Pivot, LH               | 28          | 104-8300           | 4           | Nut-Nyloc 5/16-18 Flg                 |
| 4           | 116-9682           | 1           | Mount-Pivot, RH               | 29          | 1-808280           | 2           | Pin-Clevis 5/16 X 1 49/64             |
| 5           | 32144-70           | 4           | Screw-HWH 5/16-18 X 3/4<br>Tf | 30          | 3256-23            | 4           | Washer-5/16 SAE                       |
| 6           | 109-8054           | 2           | Bushing-Flanged               | 31          | 116-6639           | 2           | Pin-Cotter, Locking                   |
| 7           | 116-9096-01        | 1           | Bracket-Mount                 | 32          | 116-9102           | 1           | Front Linkage ASM                     |
| 8           | 132-9406           | 1           | Brake Lever ASM W/ Grip       | 32:2        | 94-7572            | 1           | End-Tie Rod, RH                       |
| 8:2         | 109-8054           | 2           | Bushing-Flanged               | 32:3        | 3220-3             | 1           | Nut-Jam 3/8-24                        |
| 8:3         | 132-4749           | 1           | Grip-Lever                    | 33          | 119-1415           | 2           | Pin-Cotter, Locking                   |
| 9           | 116-9117           | 1           | Handle-Pivot, Brake           | 34          | 3296-6             | 1           | Nut-Nyloc 3/8-24                      |
| 10          | 323-11             | 1           | Screw-HH 3/8-16 X 2 1/4       | 35          | 126-7587           | 2           | Rear Linkage ASM                      |
| 11          | 104-8301           | 1           | Nut-Nyloc 3/8-16 Flg          | 35:1        | 126-7588           | 2           | Yoke                                  |
| 12          | 126-6199           | 4           | Bushing                       | 35:2        | 116-9069           | 1           | Linkage, Rear                         |
| 13          | 3256-24            | 2           | Washer-3/8 SAE                | 35:3        | 3220-1             | 1           | Nut-Jam 1/4-28                        |
| 14          | 109-0958           | 2           | Plate-Mount, Brake            | 36          | 32120-19           | 2           | E-Ring                                |
| 15          | 109-2889           | 1           | Caliper-Brake                 | 37          | 3230-2             | 2           | Bolt-Carriage 5/16-18 X 1             |
| 16          | 116-9103           | 1           | Caliper-Brake, RH             | 38          | 323-6              | 2           | Screw-HH 3/8-16 X 1                   |
| 17          | 126-4251           | 2           | Bellcrank                     | 39          | 3296-39            | 2           | Nut-Nyloc 3/8-16                      |
| 18          | 126-3715           | 1           | Arm-Inner, LH                 | 40          | 116-1746           | 2           | Wheel Hub ASM                         |
| 19          | 126-3716           | 1           | Arm-Inner, RH                 | 40:2        | 116-1696           | 4           | Stud-Wheel                            |
| 20          | 116-9080           | 1           | Shaft-Cross                   | 41          | 116-1399           | 2           | Locknut                               |
| 21          | 115-7109           | 2           | Washer-Flat                   | 42          | 126-6395           | 4           | Pin-Clevis, Spring                    |
| 22          | 98-9940            | 4           | Screw                         | 43          | 92-5727            | 2           | Screw-HH 3/8-16 X 1 1/4<br>Patch Lock |
| 23          | 116-9608           | 2           | Bracket-L                     | 44          | 126-6200           | 2           | Spacer                                |
| 24          | 116-9086           | 2           | Linkage-Mid                   |             |                    |             |                                       |
| 25          | 126-3693           | 2           | Yoke-Offset                   |             |                    |             |                                       |

# Seat Assembly



## Seat Assembly (continued)

| <i>Ref.</i> | <i>Part Number</i> | <i>Qty.</i> | <i>Description</i>                        | <i>Ref.</i> | <i>Part Number</i> | <i>Qty.</i> | <i>Description</i>               |
|-------------|--------------------|-------------|---|-------------|--------------------|-------------|----------------------------------|
| 1           | 116-8912           | 1           | Kit-Suspension Seat                       | 10          | 109-9881-03        | 1           | Plate-Latch, Seat                |
| 2           | 109-9034           | 4           | Isolator-Seat                             | 11          | 3230-4             | 1           | Bolt-Carriage 5/16-18 X 1<br>1/2 |
| 3           | 104-8301           | 4           | Nut-Nyloc 3/8-16 Flg                      | 12          | 107-3017           | 1           | Spring-Compression               |
| 4           | 116-3860-03        | 1           | Plate-Tilt, Seat Support                  | 13          | 9266934            | 2           | Screw-HWH 5/16 X 1/2 Tf          |
| 5           | 3230-23            | 11          | Bolt-Carriage 5/16-18 X 3/4<br>Short Neck | 14          | 126-6574           | 1           | Decal, Lazer Model               |
| 6           | 104-8300           | 18          | Nut-Nyloc 5/16-18 Flg                     | 15          | 116-1297           | 2           | Screw-Shoulder                   |
| 7           | 116-3859-03        | 1           | Plate-Frame, Seat                         | 16          | 116-0070           | 1           | Rod-Prop                         |
| 8           | 26-4840            | 4           | Spacer-Pin, Mounting                      | 17          | 3256-23            | 1           | Washer-5/16 SAE                  |
| 9           | 116-2130-03        | 1           | Panel-Front, Seat Mount                   | 18          | 114-4465           | 1           | Decal-Service Aid                |

# Seat Assembly (cont.)





## Seat Assembly (cont.) (continued)

| <i>Ref.</i> | <i>Part Number</i> | <i>Qty.</i> | <i>Description</i>           | <i>Ref.</i> | <i>Part Number</i> | <i>Qty.</i> | <i>Description</i>    |
|-------------|--------------------|-------------|------------------------------|-------------|--------------------|-------------|-----------------------|
| 2           | 116-8910           | 1           | Seat Track Set               | 7           | 126-2061           | 1           | Seat Belt Service Kit |
| 3           | 116-8908           | 1           | Cover-Back 311463Vn500       | 8           | 116-8906           | 1           | Kit-Arm Rest Set      |
| 4           | 116-8909           | 1           | Cover-Cushion<br>311464Vn500 | 9           | 116-8905           | 1           | Kit-Arm Rest Pads     |
| 5           | 116-8911           | 1           | Knob-Adjuster                | 10          | 82-2190            | 1           | Switch                |
| 6           | 116-5659           | 1           | Cover-Suspension Bellows     | 11          | 116-9329           | 4           | Spacer                |
|             |                    |             |                              | 12          | 126-9918-03        | 2           | Stop, Seat ●          |

● Used on Diesel models only

# Fuel Assembly

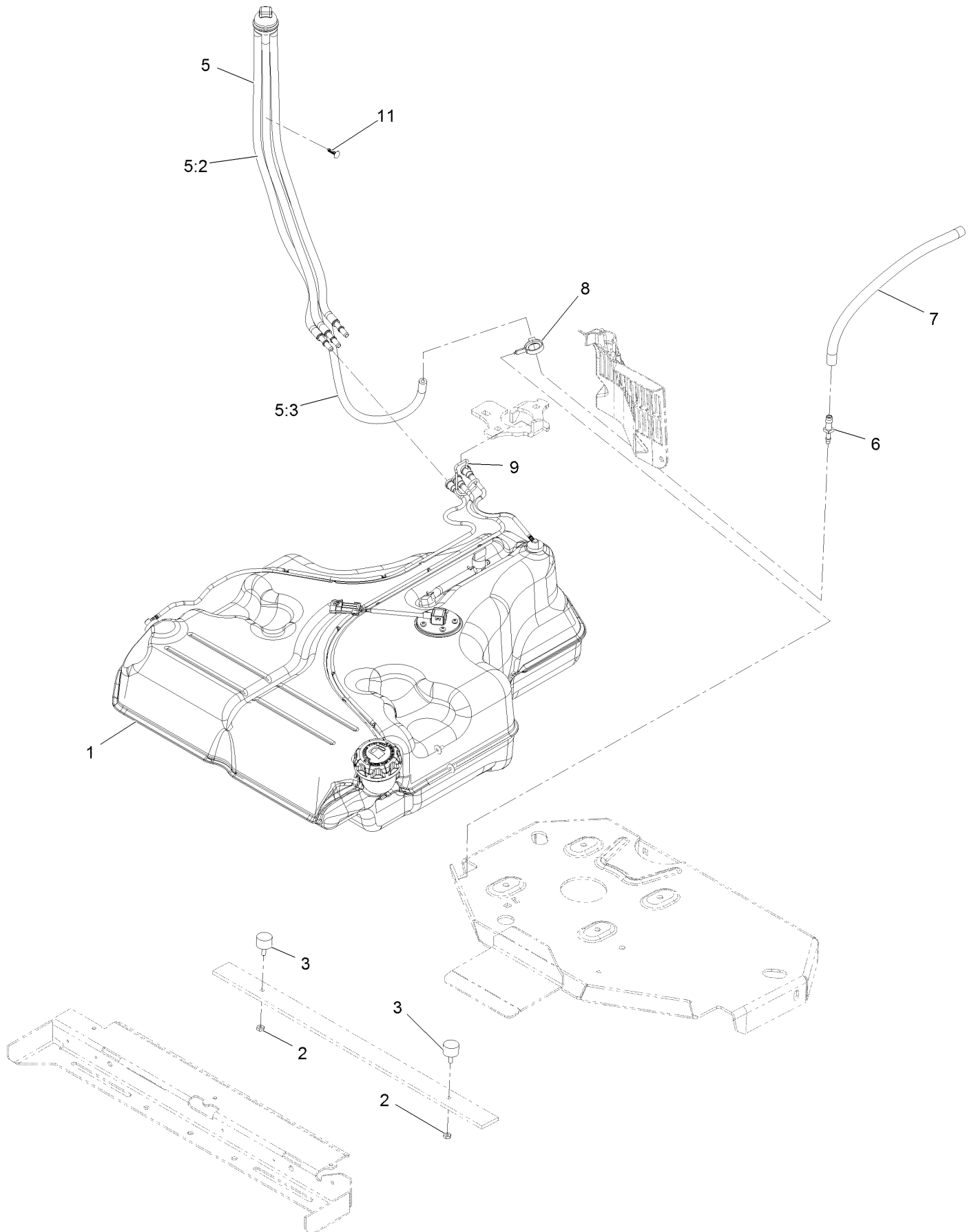

## Fuel Assembly (continued)

| <i>Ref.</i> | <i>Part Number</i> | <i>Qty.</i> | <i>Description</i>     | <i>Ref.</i> | <i>Part Number</i> | <i>Qty.</i> | <i>Description</i>   |
|-------------|--------------------|-------------|------------------------|-------------|--------------------|-------------|----------------------|
| 1           | 135-0643           | 1           | Fuel Tank ASM          | 6           | 116-5072           | 1           | Fitting-Straight     |
| 2           | 3218-1             | 2           | Nut-Jam                | 7           | 116-5087           | 1           | Hose-Fuel            |
| 3           | 1-523420           | 2           | Bumper                 | 8           | 105-1853           | 1           | Clamp-Hose           |
| 5           | 127-0583           | 1           | Fuel Manifold Vent ASM | 9           | 116-6005           | 1           | Retainer-Line, Vapor |
| 5:2         | 109-0302           | 3           | Hose-Fuel              | 11          | 125-8067           | 1           | Plug-Plastic         |
| 5:3         | 108-5376           | 1           | Hose-Fuel              |             |                    |             |                      |

# Fuel Tank Assembly

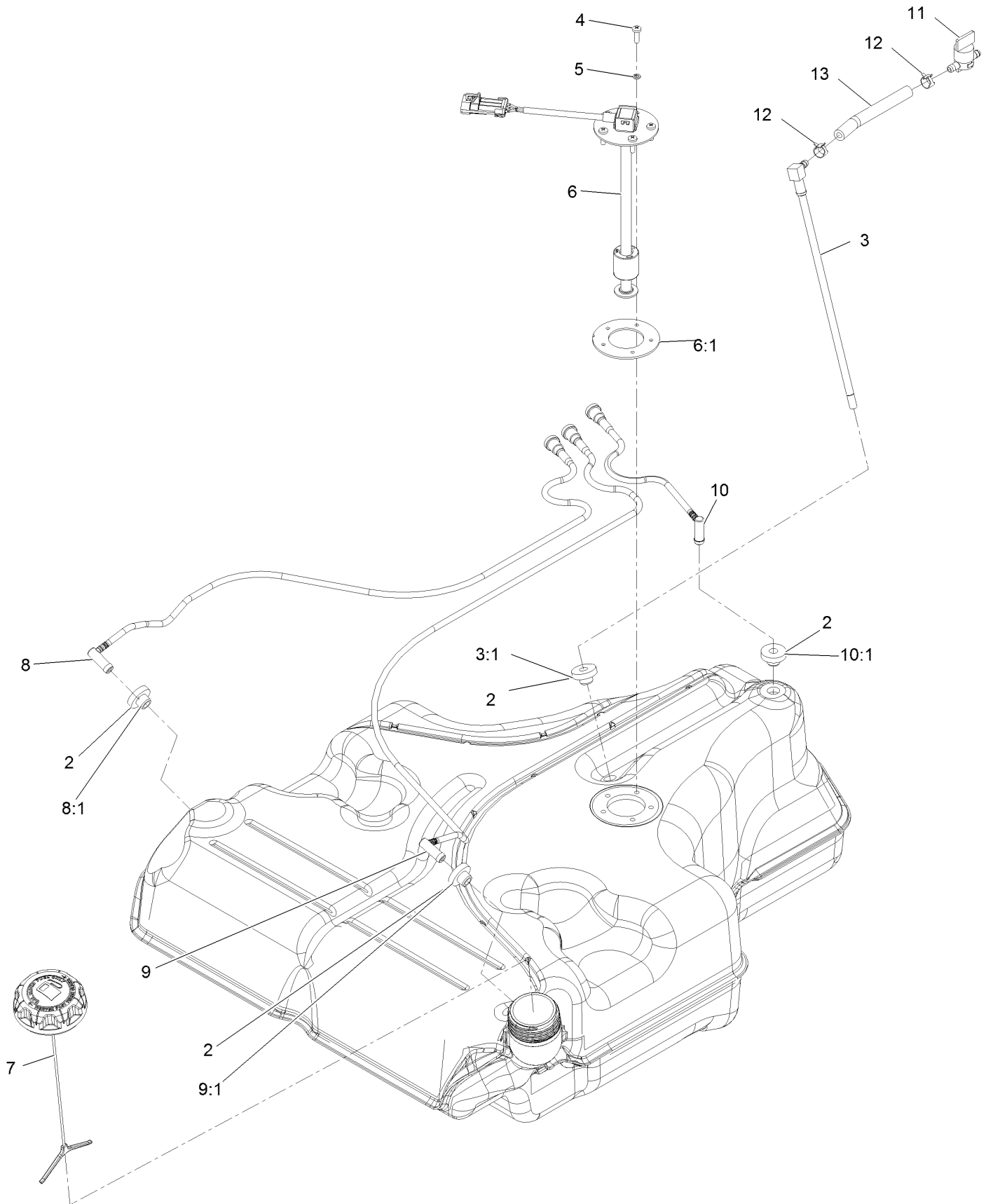

## Fuel Tank Assembly (continued)

| <i>Ref.</i> | <i>Part Number</i> | <i>Qty.</i> | <i>Description</i>              | <i>Ref.</i> | <i>Part Number</i> | <i>Qty.</i> | <i>Description</i>                |
|-------------|--------------------|-------------|---------------------------------|-------------|--------------------|-------------|-----------------------------------|
| 2           | 46-6560            | 4           | Bushing                         | 8:1         | 46-6560            | 1           | Bushing                           |
| 3           | 116-2459           | 1           | Fuel Line Kit (With Grommet)    | 9           | 116-2461           | 1           | LH Vent Line Kit (With Grommet)   |
| 3:1         | 46-6560            | 1           | Bushing                         | 9:1         | 46-6560            | 1           | Bushing                           |
| 4           | 3290-500           | 5           | Screw-PPH                       | 10          | 116-2462           | 1           | Rear Vent Line Kit (With Grommet) |
| 5           | 3253-17            | 5           | Washer-Lock                     | 10:1        | 46-6560            | 1           | Bushing                           |
| 6           | 126-3913           | 1           | Float-Sender, Fuel              | 11          | 1-603770           | 1           | Valve-Fuel                        |
| 6:1         | 126-3950           | 1           | Gasket-Sender                   | 12          | 2412-98            | 2           | Clamp-Hose                        |
| 7           | 126-1789           | 1           | Cap-Fuel, Ratcheting            | 13          | 109-0650           | 1           | Hose-Fuel                         |
| 8           | 116-2460           | 1           | RH Vent Line Kit (With Grommet) |             |                    |             |                                   |

# Engine Assembly

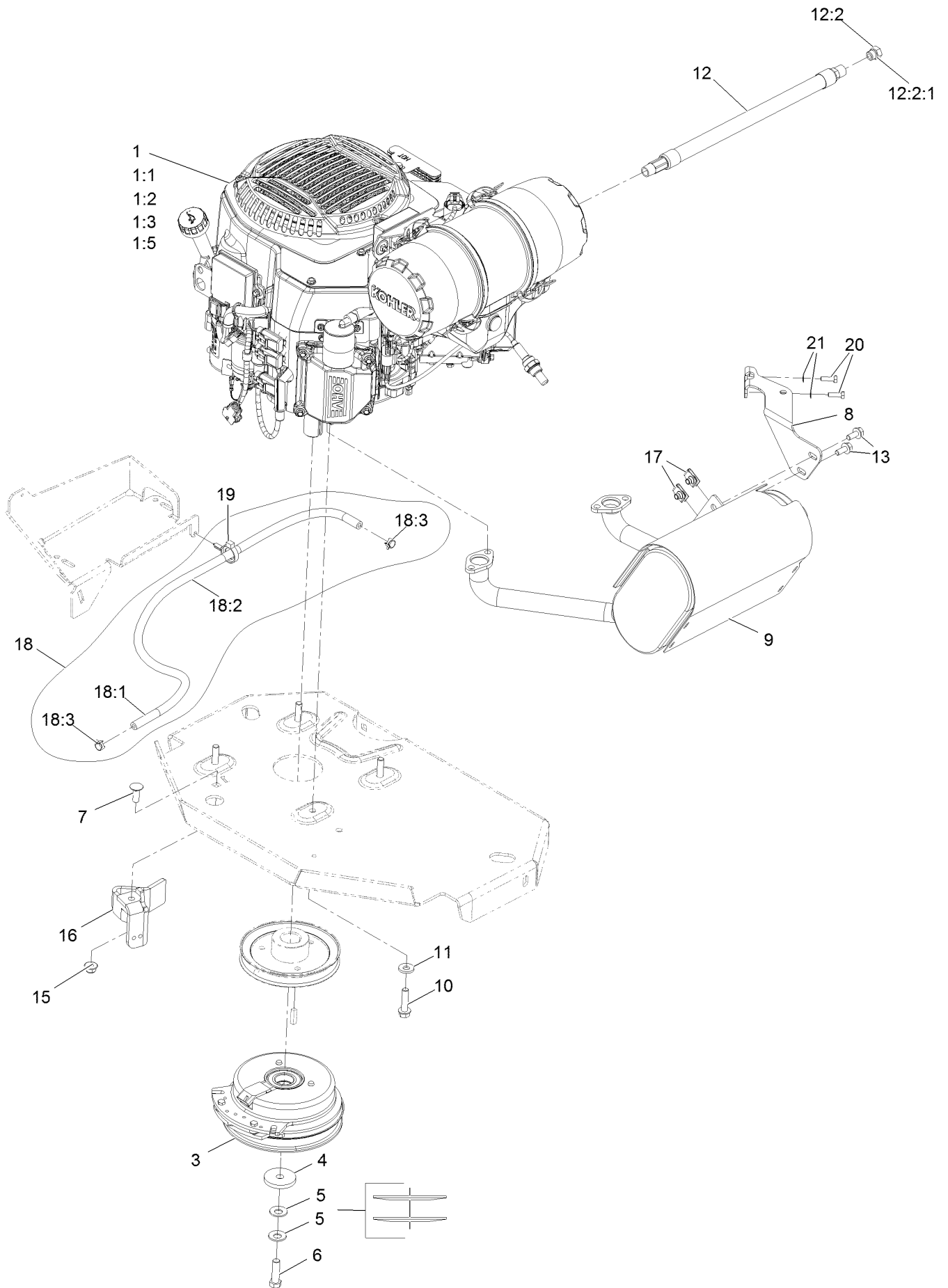

## Engine Assembly (continued)

| <i>Ref.</i> | <i>Part Number</i> | <i>Qty.</i> | <i>Description</i>                         | <i>Ref.</i> | <i>Part Number</i> | <i>Qty.</i> | <i>Description</i>              |
|-------------|--------------------|-------------|--|-------------|--------------------|-------------|---------------------------------|
| 1           |                    | 1           | Engine-Kohler Ecv740-3055<br>■▲            | 11          | 98-5975            | 4           | Washer-Spring Disc 3/8          |
| 1:1         |                    | 1           | Kohler 52 050 02-S Engine<br>Oil Filter ■▲ | 12          | 116-5316           | 1           | Oil Drain Hose ASM              |
| 1:2         |                    | 1           | Kohler 25 083 01-S Engine<br>Air Filter ■▲ | 12:2        | 353-508            | 1           | Plug-W/O-Ring ●                 |
| 1:3         |                    | 1           | Kohler 25 083 04-S Safety<br>Filter ■▲     | 12:2:1      | 237-42             | 1           | O-Ring                          |
| 1:5         | 135-2483           | 1           | Kohler 25 050 42-S Fuel<br>Filter          | 13          | 3234-5             | 2           | Screw-HH Flg 5/16-18 X 3/4      |
| 3           | 116-1620           | 1           | Clutch Kit                                 | 15          | 104-8301           | 1           | Nut-Nyloc 3/8-16 Flg            |
| 4           | 109-6919           | 1           | Washer-Clutch                              | 16          | 116-2612-01        | 1           | Clutch-Anchor                   |
| 5           | 1-603610           | 2           | Washer-Spring Disc 7/16                    | 17          | 94-2413            | 2           | Nut-U                           |
| 6           | 109-9761           | 1           | Screw-HH 7/16-20 X 1 1/2<br>W/Loctite ◆    | 18          | 117-3893           | 1           | Fuel Line ASM                   |
| 7           | 3231-22            | 1           | Bolt-Carriage 3/8-16 X 1                   | 18:1        | 109-0273           | 1           | Hose-Fuel Line 38 1/4"          |
| 8           | 116-4297           | 1           | Muffler Bracket Kit                        | 18:2        | 117-3892           | 1           | Sleeve-Thermal                  |
| 9           | 135-2127           | 1           | Muffler Kit                                | 18:3        | 2412-98            | 2           | Clamp-Hose                      |
| 10          | 32144-102          | 4           | Screw-HWH 3/8-16 X 1 1/2<br>Taptite        | 19          | 105-1853           | 1           | Clamp-Hose                      |
|             |                    |             |  | 20          | 116-4295           | 2           | Screw-HH M6-1 X 20Mm<br>W/Patch |
|             |                    |             |  | 21          | 1-303435           | 2           | Washer-Spring Disc 1/4          |

● Torque to 24-26 ft-lb

▲ Obtain parts from [www.kohlerplus.com](http://www.kohlerplus.com)

◆ Use Pro-Lock, Nut Type (P/N 1-840022, .5ml tube) on threads.

■ Not serviced separately

# Hydraulic Assembly

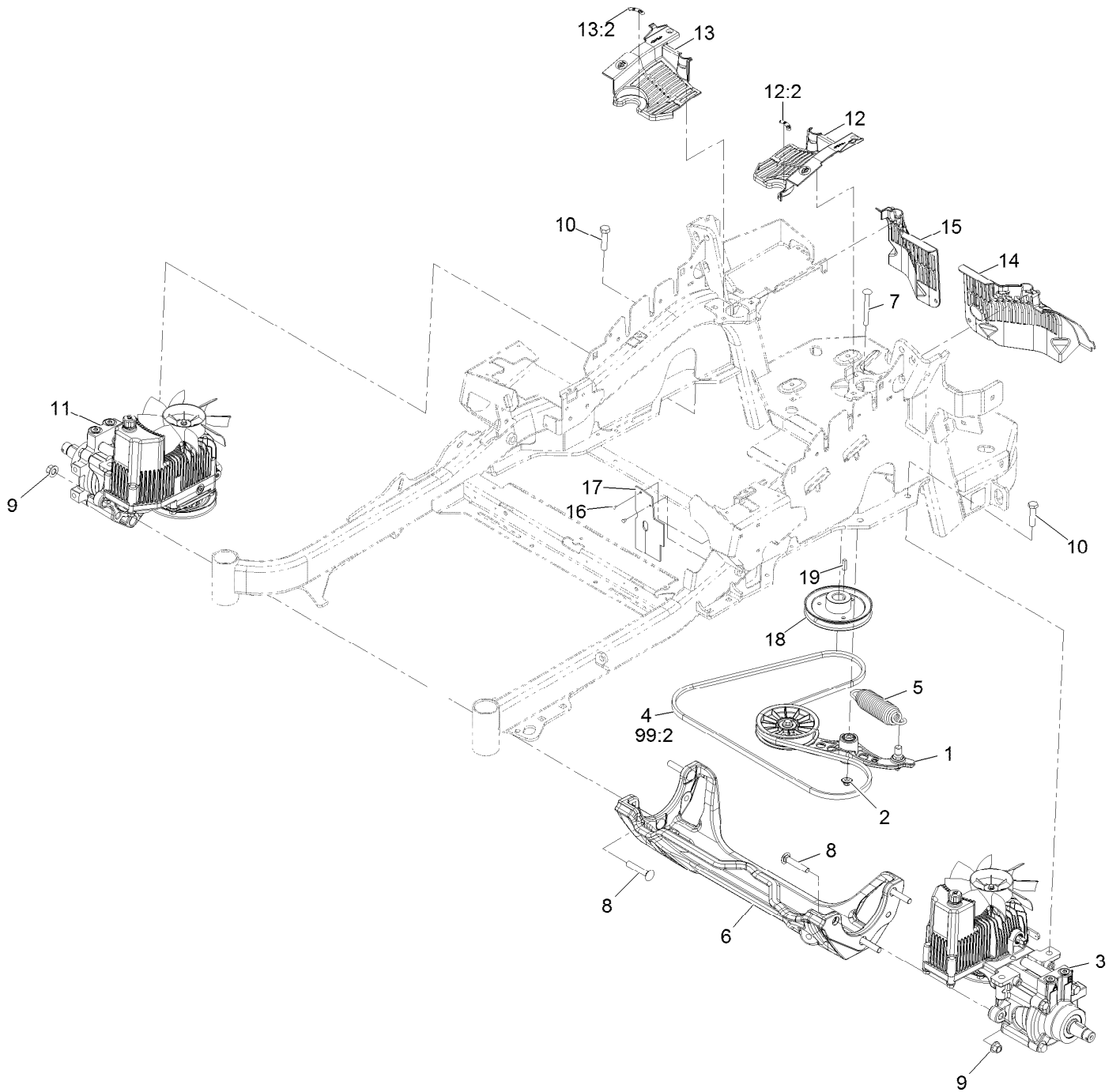



## Hydraulic Assembly (continued)

| <i>Ref.</i> | <i>Part Number</i> | <i>Qty.</i> | <i>Description</i>                       | <i>Ref.</i> | <i>Part Number</i> | <i>Qty.</i> | <i>Description</i>                 |
|-------------|--------------------|-------------|--|-------------|--------------------|-------------|------------------------------------|
| 1           | 116-1255           | 1           | Pump Idler ASM                           | 13          | 116-0171           | 1           | RH Hydro Guard ASM                 |
| 2           | 109-6658           | 1           | Nut-Nyloc 3/8-16 Flg                     | 13:2        | 116-8726           | 1           | Decal-Oil, Hydro                   |
| 3           | 126-1321           | 1           | LH Hydro ASM (12Cc W/<br>Check)          | 14          | 109-9057           | 1           | Guard-Hydro, Rear (LH)             |
| 4           | 109-3388           | 1           | Belt                                     | 15          | 109-9058           | 1           | Guard-Hydro, Rear (RH)             |
| 5           | 116-6317           | 1           | Spring-Extension                         | 16          | 1-803035           | 2           | Rivet 3/16 X 1/4                   |
| 6           | 116-7558           | 1           | Cradle-Hydro                             | 17          | 116-2362           | 1           | Deflector-Air Flow                 |
| 7           | 116-1502           | 1           | Bolt-Carriage Shoulder<br>3/8-16 X 3 1/2 | 18          | 109-9905           | 1           | Sheave                             |
| 8           | 126-0095           | 6           | Screw-CARR                               | 19          | 1-807259           | 1           | Key                                |
| 9           | 99-5107            | 6           | Nut-Lock 1/2-13                          | 99          | 109-9828           | 1           | Bottle-Oil, 32Oz Hydraulic ●       |
| 10          | 325-8              | 4           | Screw-HH 1/2-13 X 1 1/4                  | 99          | 116-0164           | 1           | Filter-Hydro ●                     |
| 11          | 126-1322           | 1           | RH Hydro ASM (12Cc W/<br>Check)          | 99          | 116-1218           | 1           | Bottle,Oil 1 Gallon Hydraulic<br>● |
| 12          | 116-0170           | 1           | LH Hydro Guard ASM                       | 99          | 116-3270           | 1           | Kit, Hydro Service ●               |
| 12:2        | 116-8726           | 1           | Decal-Oil, Hydro                         | 99:1        | 109-9828           | 4           | Bottle-Oil, 32Oz Hydraulic ●       |
|             |                    |             |  | 99:2        | 109-3388           | 1           | Belt                               |
|             |                    |             |  | 99:3        | 116-0164           | 2           | Filter-Hydro ●                     |

● Not illustrated

# Pump Idler Assembly No. 116-1255

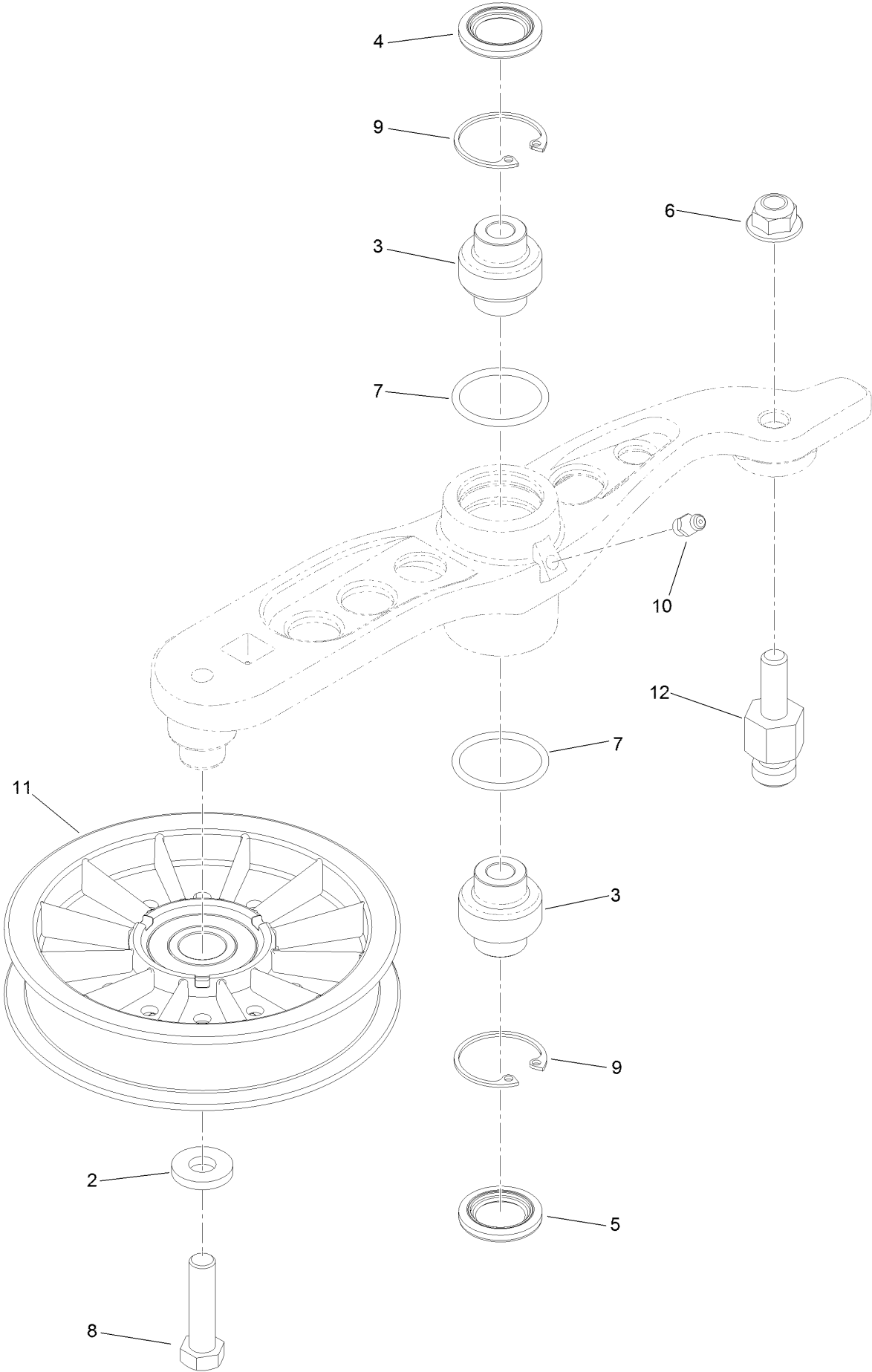

## Pump Idler Assembly No. 116-1255 (continued)

| <i>Ref.</i> | <i>Part Number</i> | <i>Qty.</i> | <i>Description</i> | <i>Ref.</i> | <i>Part Number</i> | <i>Qty.</i> | <i>Description</i> |
|-------------|--------------------|-------------|--------------------|-------------|--------------------|-------------|--------------------|
| 2           | 43-0940            | 1           | Spacer             | 8           | 323-8              | 1           | Screw-HH           |
| 3           | 103-3504           | 2           | Bearing-Spherical  | 9           | 32120-10           | 2           | Ring-Snap          |
| 4           | 103-3505           | 1           | Seal-Lip, Double   | 10          | 302-19             | 1           | Fitting-Grease     |
| 5           | 103-3506           | 1           | Seal-Lip, Single   | 11          | 109-8076           | 1           | Pulley-Idler       |
| 6           | 109-6658           | 1           | Nut-Flange, NI     | 12          | 132-4724           | 1           | Pin-Anchor, Spring |
| 7           | 106-7159           | 2           | O-Ring             |             |                    |             |                    |

# LH Hydro Assembly No. 126-1321

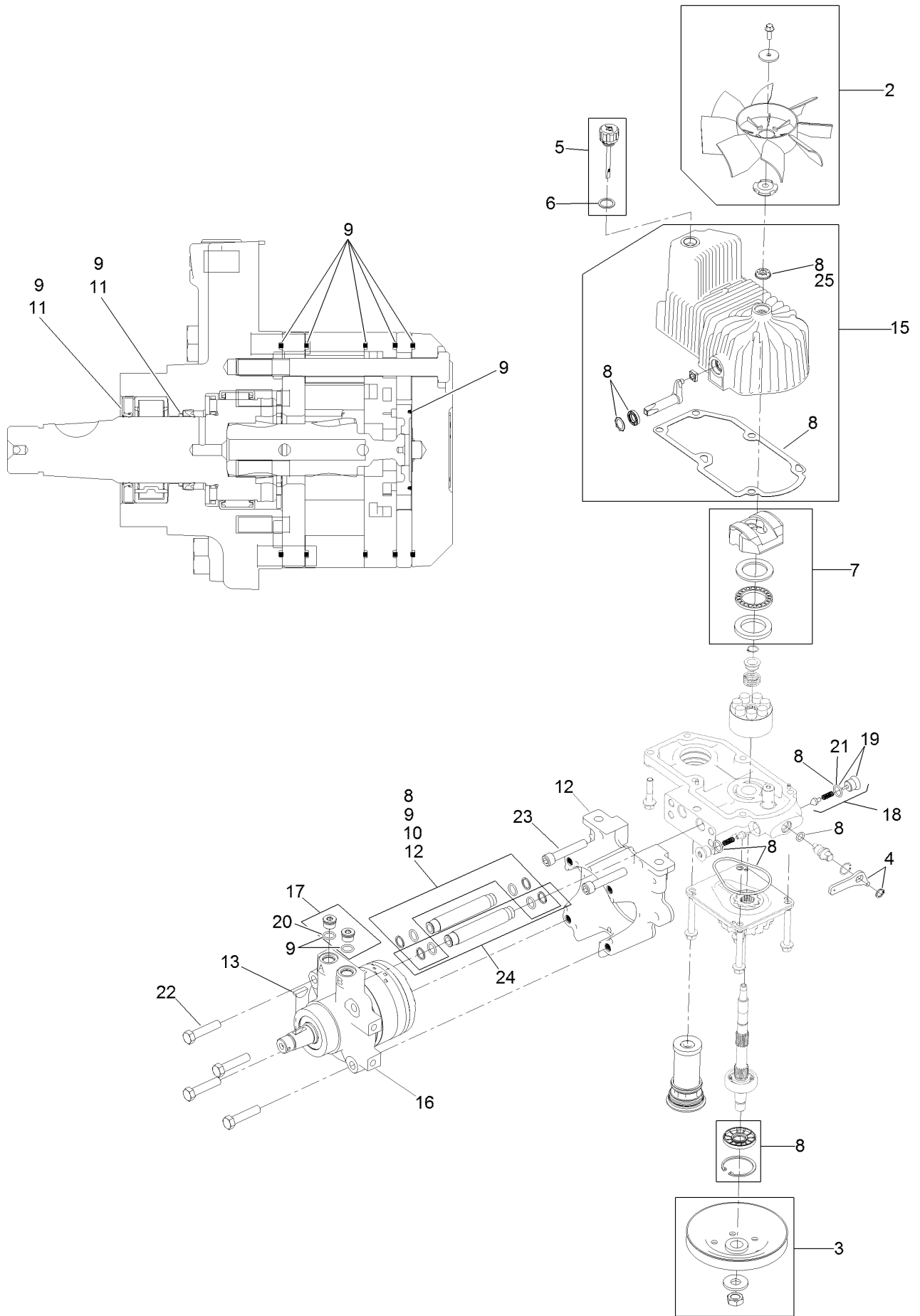

## LH Hydro Assembly No. 126-1321 (continued)

| <i>Ref.</i> | <i>Part Number</i> | <i>Qty.</i> | <i>Description</i>            | <i>Ref.</i> | <i>Part Number</i> | <i>Qty.</i> | <i>Description</i>         |
|-------------|--------------------|-------------|-------------------------------|-------------|--------------------|-------------|----------------------------|
| 2           | 116-0233           | 1           | Fan Kit                       | 15          | 116-3287           | 1           | Housing-LH                 |
| 3           | 116-0234           | 1           | Pulley Kit                    | 16          | 116-8915           | 1           | Motor-Hydraulic LH 240Cc   |
| 4           | 116-0235           | 1           | Handle-Bypass Valve,<br>Hydro | 17          | 116-7901           | 1           | Magnetic Plugs Service Kit |
| 5           | 116-0236           | 1           | Dipstick-Hydro W/Gasket       | 18          | 116-1630           | 2           | Check Valve ASM            |
| 6           | 116-0237           | 1           | Gasket-Dipstick, Hydro        | 19          | 116-1631           | 2           | Plug-Check (W/O-Ring)      |
| 7           | 116-1367           | 1           | Swash Block Kit               | 20          | 76-1900            | 2           | O-Ring                     |
| 8           | 116-1368           | 1           | Pump Seal Kit                 | 21          | 116-8662           | 2           | O-Ring-Check Valve         |
| 9           | 116-1369           | 1           | Motor Seal Kit                | 22          | 116-8974           | 4           | Screw HH                   |
| 10          | 116-1370           | 1           | Tube Seal Kit                 | 23          | 116-8975           | 2           | Screw-HSH                  |
| 11          | 116-1371           | 1           | Output Shaft Seal Kit         | 24          | 116-9922           | 2           | Hydraulic Tube Kit         |
| 12          | 116-5469           | 1           | Nose Cup-Uht                  | 25          | 126-7711           | 1           | Seal-Fan Drive             |
| 13          | 3257-42            | 1           | Key-Woodruff                  | 99          | 116-1373           | 1           | Flow Test Kit ●            |
|             |                    |             |                               | 99          | 116-4245           | 1           | Puller-Pulley ●            |

● Not illustrated

# RH Hydro Assembly No. 126-1322

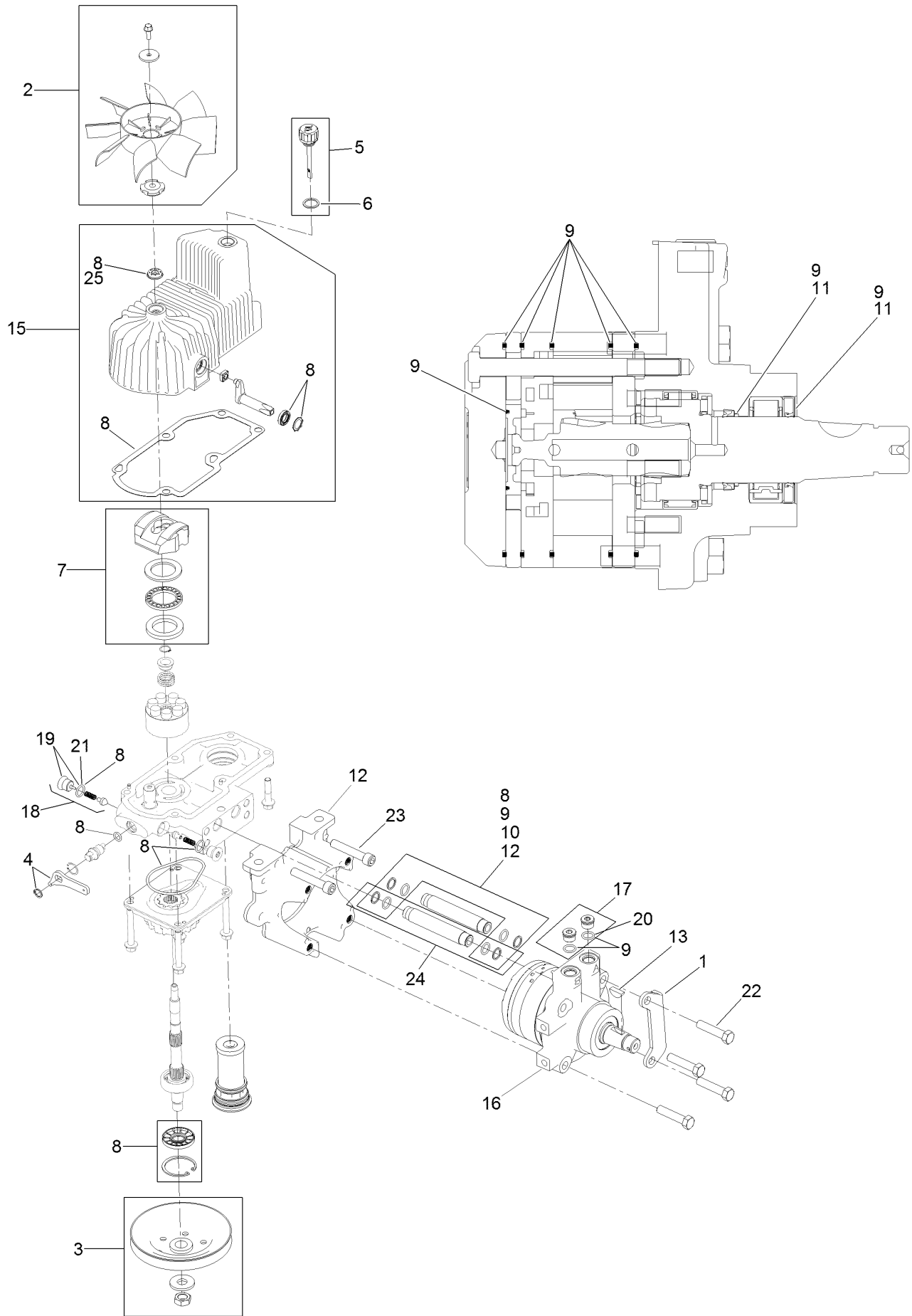

## RH Hydro Assembly No. 126-1322 (continued)

| <i>Ref.</i> | <i>Part Number</i> | <i>Qty.</i> | <i>Description</i>            | <i>Ref.</i> | <i>Part Number</i> | <i>Qty.</i> | <i>Description</i>         |
|-------------|--------------------|-------------|-------------------------------|-------------|--------------------|-------------|----------------------------|
| 1           | 116-9063           | 1           | Mount-Shoe, Horse             | 15          | 116-3288           | 1           | Housing-RH                 |
| 2           | 116-0233           | 1           | Fan Kit                       | 16          | 116-8916           | 1           | Motor-Hydraulic RH 240Cc   |
| 3           | 116-0234           | 1           | Pulley Kit                    | 17          | 116-7901           | 1           | Magnetic Plugs Service Kit |
| 4           | 116-0235           | 1           | Handle-Bypass Valve,<br>Hydro | 18          | 116-1630           | 2           | Check Valve ASM            |
| 5           | 116-0236           | 1           | Dipstick-Hydro W/Gasket       | 19          | 116-1631           | 2           | Plug-Check (W/O-Ring)      |
| 6           | 116-0237           | 1           | Gasket-Dipstick, Hydro        | 20          | 76-1900            | 2           | O-Ring                     |
| 7           | 116-1367           | 1           | Swash Block Kit               | 21          | 116-8662           | 2           | O-Ring-Check Valve         |
| 8           | 116-1368           | 1           | Pump Seal Kit                 | 22          | 116-8974           | 4           | Screw HH                   |
| 9           | 116-1369           | 1           | Motor Seal Kit                | 23          | 116-8975           | 2           | Screw-HSH                  |
| 10          | 116-1370           | 1           | Tube Seal Kit                 | 24          | 116-9922           | 2           | Hydraulic Tube Kit         |
| 11          | 116-1371           | 1           | Output Shaft Seal Kit         | 25          | 126-7711           | 1           | Seal-Fan Drive             |
| 12          | 116-5469           | 1           | Nose Cup-Uht                  | 99          | 116-1373           | 1           | Flow Test Kit ●            |
| 13          | 3257-42            | 1           | Key-Woodruff                  | 99          | 116-4245           | 1           | Puller-Pulley ●            |

● Not illustrated

# Electrial Assembly

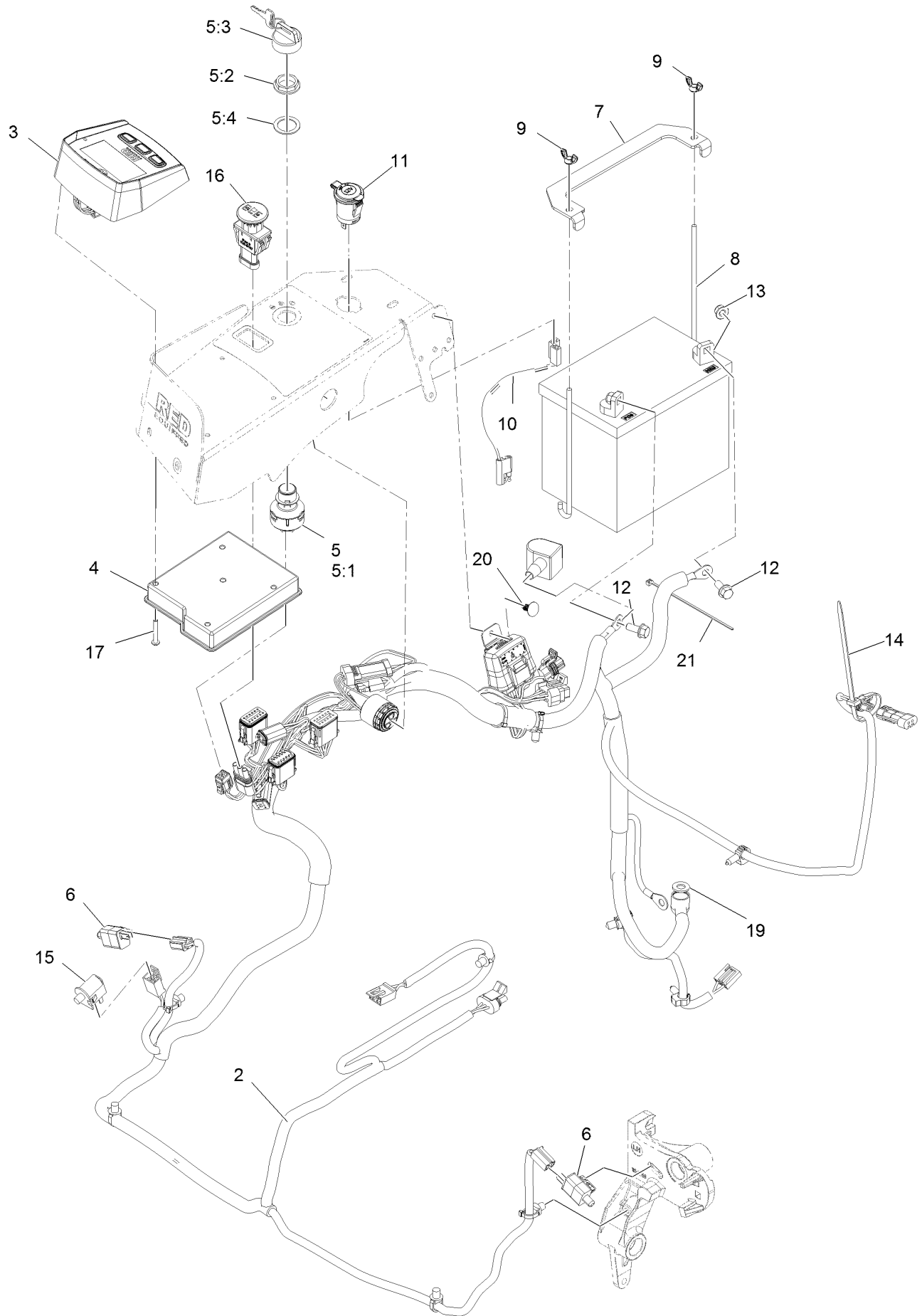



## Electrial Assembly (continued)

| <i>Ref.</i> | <i>Part Number</i> | <i>Qty.</i> | <i>Description</i>      | <i>Ref.</i> | <i>Part Number</i> | <i>Qty.</i> | <i>Description</i>         |
|-------------|--------------------|-------------|-------------------------|-------------|--------------------|-------------|----------------------------|
| 2           | 135-2305           | 1           | Harness-Wiring          | 10          | 126-7290           | 1           | Harness-Receptacle, 12V    |
| 3           | 126-4232           | 1           | Module, Ldu             | 11          | 126-6499           | 1           | Port-Power, 12V            |
| 4           | 126-4233           | 1           | Module                  | 12          | 3234-5             | 2           | Screw-HH Flg 5/16-18 X 3/4 |
| 5           | 126-6285           | 1           | Ignition Switch ASM     | 13          | 104-8300           | 2           | Nut-Nyloc 5/16-18 Flg      |
| 5:1         |                    | 1           | Switch-Ignition ●       | 14          | 1-303335           | 1           | Tie-Cable 7 15/16 (Large)  |
| 5:2         | 108-8660           | 1           | Nut-Mounting            | 15          | 82-2190            | 1           | Switch                     |
| 5:3         | 106-5270           | 1           | Ignition Key Set        | 16          | 126-6187           | 1           | Switch-PTO, Sealed         |
| 5:4         | 108-8659           | 1           | Washer-Backup           | 17          | 126-5092           | 4           | Screw-PPH                  |
| 6           | 110-6765           | 2           | Switch                  | 19          | 3256-24            | 1           | Washer-3/8 SAE             |
| 7           | 116-0042-03        | 1           | Strap-Tie Down, Battery | 20          | 117-2382           | 1           | Plug-Plastic               |
| 8           | 1-633651           | 2           | Bolt-Holddown           | 21          | 1-303287           | 1           | Tie-Cable                  |
| 9           | 1-543792           | 2           | Wingnut-Nyloc 1/4-20    |             |                    |             |                            |

● Not serviced separately

# Wire Harness Assembly No. 135-2305

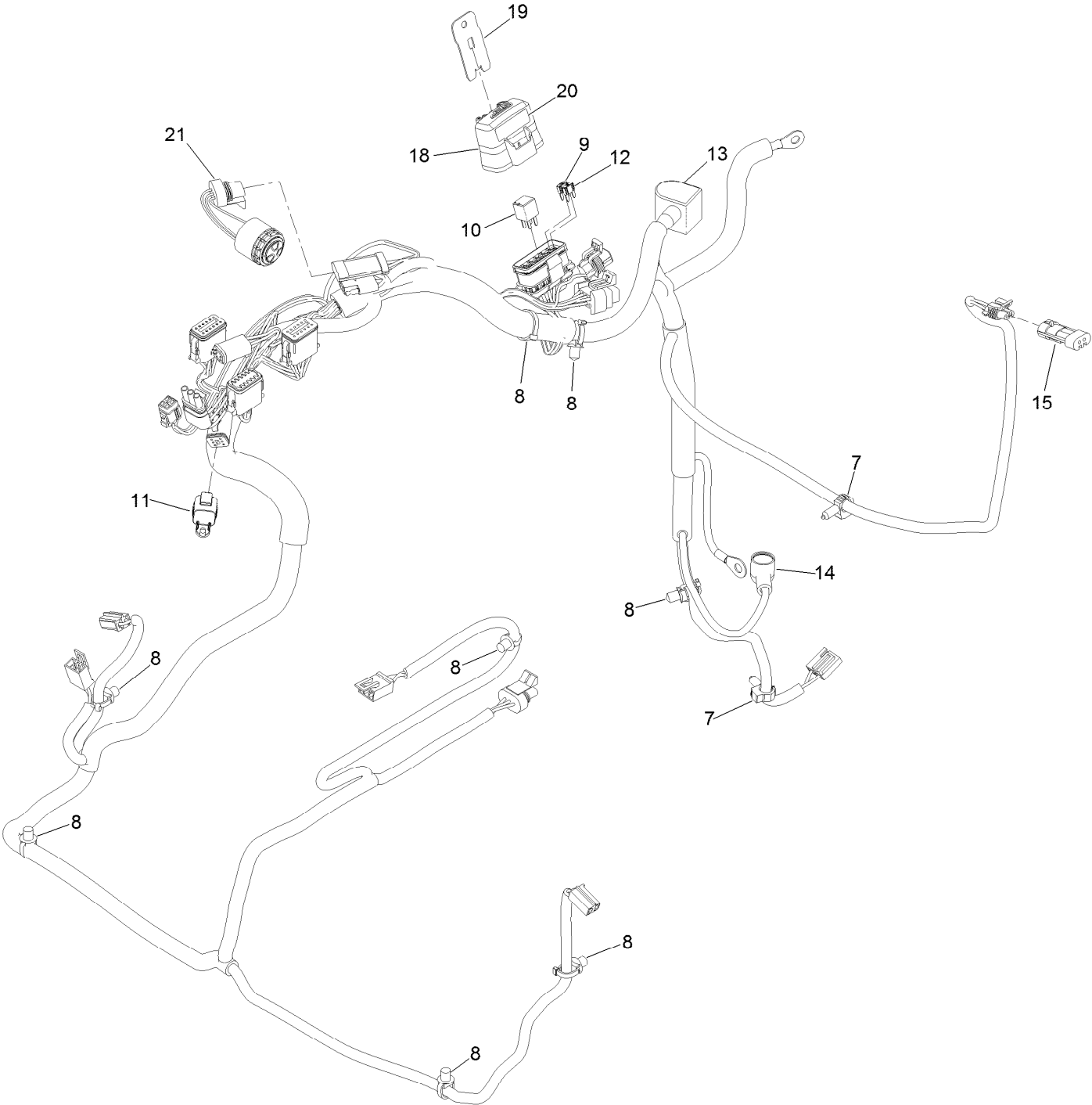

## Wire Harness Assembly No. 135-2305 (continued)

| <i>Ref.</i> | <i>Part Number</i> | <i>Qty.</i> | <i>Description</i>      | <i>Ref.</i> | <i>Part Number</i> | <i>Qty.</i> | <i>Description</i> |
|-------------|--------------------|-------------|-------------------------|-------------|--------------------|-------------|--------------------|
| 7           | 32180-037          | 2           | Clip-Harness            | 14          | 1-543393           | 1           | Insulator-Solenoid |
| 8           | 32180-030          | 8           | Clip-Tie                | 15          | 32160-070          | 1           | Connector          |
| 9           | 121-8868           | 1           | Fuse-Mini Blade, 20 Amp | 18          | 32180-176          | 1           | Cover-Block, Fuse  |
| 10          | 126-3991           | 1           | Relay-Micro             | 19          | 32180-177          | 1           | Clip-Mounting      |
| 11          | 32180-156          | 1           | Cap-Plug, 6 Way         | 20          | 126-7875           | 1           | Decal-Fuse         |
| 12          | 121-8867           | 1           | Fuse-Mini Blade, 15 Amp | 21          | 126-6286           | 1           | Alarm-Dual Tone    |
| 13          | 126-8876           | 1           | Insulator-Battery       |             |                    |             |                    |

**Notes:**

**Notes:**

**Notes:**



# MAXIMIZE THE PERFORMANCE OF YOUR EXMARK MACHINE.



## EXMARK® PREMIUM ENGINE OIL

Exmark now offers a family of engine oil viscosities to perform well in any environment. Each viscosity has the same synthetic formulation to give you what you need in punishing conditions. We designed each grade to the highest quality, making it ideal even for diesel applications. Coupled with Exmark Premium Fuel Treatment, we have the performance products to make your machine hum.

### EXMARK PREMIUM ENGINE OIL SAE 30/10W-30

- Meets zero shear requirements of a straight grade SAE 30 as well as the cold temp properties of a 10W-30.
- Most versatile oil in the industry.
- Superior corrosion protection over conventional oil - even in corrosive, humid environments.

### EXMARK PREMIUM ENGINE OIL SAE 20W-50

- Perfect for your big block engine, or any application in severe service.
- Same full synthetic formulation as all other Exmark Premium viscosities.
- Also effective for use in severe service small block engines.

### EXMARK PREMIUM ENGINE OIL SAE 10W-50

- Full synthetic formulation gives you peak performance. Don't settle for less.
- Wide span multi-grade combines easy starting in cold weather with maximum protection in high temperature operation.
- Reduce friction & wear over standard mineral formulations.

### EXMARK PREMIUM ENGINE OIL SAE 0W-40

- The perfect choice for when the weather turns cold or unpredictable, and your Exmark UTV has to perform.
- Commercial quality for severe service.
- Advanced additive package helps prevent corrosion from long-term storage.

### EXMARK PREMIUM ENGINE OIL UTV FORMULATION

- 4-cycle high-temp formulation.
- Heavier viscosity, full synthetic, perfect for your UTV.

### EXMARK PREMIUM UTV EXTREME CONDITIONS GEAR OIL

- SAE 80W-90, designed to keep your UTV performing at its peak.
- Shear stable, hypoid gear lube.
- Includes a premium additive system to combat wear, oxidation, rust & corrosion.

**Available from your local Exmark dealer. Find your closest dealer at [exmark.com](http://exmark.com)**

## EXMARK ACCESSORIES AND OPTIONS\*

### MID-MOUNT RIDING ACCESSORIES AND OPTIONS

|                                    |                                 |
|------------------------------------|---------------------------------|
| CUSTOM RIDE SEAT SUSPENSION SYSTEM | OPERATOR CONTROLLED DISCHARGE   |
| FULL SUSPENSION SEAT               | SUN SHADE                       |
| DECK LIFT ASSIST KIT               | TRASH CONTAINER                 |
| HITCH KIT                          | TURF STRIPER                    |
| LIGHT KIT                          | ULTRA VAC COLLECTION SYSTEM     |
| 12V POWER PORT                     | ULTRA VAC QUICK DISPOSAL SYSTEM |
| MICRO-MULCH SYSTEM                 |                                 |

### OUT-FRONT RIDING ACCESSORIES AND OPTIONS

|                                    |                                 |
|------------------------------------|---------------------------------|
| CUSTOM RIDE SEAT SUSPENSION SYSTEM | SNOW BLADE                      |
| DUAL-TAIL WHEEL                    | SNOWBLOWER                      |
| FLOOR PAN EXTENDER                 | SUN SHADE                       |
| HITCH KIT                          | TRASH CONTAINER                 |
| LIGHT KIT                          | ULTRA VAC COLLECTION SYSTEM     |
| MICRO-MULCH SYSTEM                 | ULTRA VAC QUICK DISPOSAL SYSTEM |
| ROLL OVER PROTECTION SYSTEM (ROPS) | WEATHER CAB                     |

### WALK-BEHIND ACCESSORIES AND OPTIONS

|                    |              |
|--------------------|--------------|
| GRASS CATCHER      | TURF STRIPER |
| MICRO-MULCH SYSTEM | STANDON      |

\*Some accessories and options not available for some models.

Place Model No. and Serial No.  
Label Here (Included in the Literature  
Pack) or Fill in Below

Model No. \_\_\_\_\_

Serial No. \_\_\_\_\_

Date Purchased \_\_\_\_\_

Engine Model No. and Spec. No. \_\_\_\_\_

Engine Serial No. (E/No) \_\_\_\_\_

© 2017 Exmark Mfg. Co., Inc.  
Industrial Park Box 808  
Beatrice, NE 68310  
All Rights Reserved

Part No. 4503-733 Rev. A  
(402) 223-6375  
Fax (402) 223-5489  
Printed in the USA.



[www.exmark.com](http://www.exmark.com)