



RADIUS S-SERIES

Model No. RAS708GEM483C3—Serial No. 402082300 and Up

Picture below may not reflect actual product.



Parts Manual

Part No. 4503-537 Rev. A

Ordering Replacement Parts

To order replacement parts, please supply the part number, the quantity, and the description of each part desired.

Understanding Reference Numbers

Each identified part in an illustration has a reference number. The reference number for a part also appears in the parts list, along with other information about the part.

This catalog uses two special reference number formats, one to indicate parts in a service assembly and another to indicate the quantity of a given part in an illustration.

Service Assembly Reference Numbers

Parts in service assemblies have reference numbers in the form a:b. The a represents the reference number of the entire service assembly and the b represents a sequential number unique to each part within the service assembly.

For example, a wheel assembly might be identified by reference number 6, the tire by 6:1, the valve by 6:2, and the wheel by 6:3. When you order the assembly identified by reference number 6, you receive all parts identified by reference numbers 6:1, 6:2, and 6:3. However, you may also order any part individually. Reference numbers of this type appear in illustration and in parts lists.

Reference Numbers Indicating Quantity

In an illustration, if a reference number indicates more than one part, the reference number has the form nX y. The n represents the quantity of the part, the X is the multiplication symbol, and the y represents the reference number.

For example, in an illustration, the reference number 2X 37 means that two of the parts identified by reference number 37 are indicated.

Touch Up Paint

Exmark black touch up spray paint – gloss black.

Exmark red touch up paint (spray paint – P/N 1-850337 - .6 oz liquid bottle – P/N 103-9140).



If your Exmark dealer does not have the Exmark part in stock, Exmark will get the parts to the dealer the next business day or the part will be FREE Guaranteed!! (Some restrictions apply. See your participating Exmark Dealer for details.)

Contents

Complete Deck Assembly	4
Deck Assembly	6
Deck W/Decals Assembly	8
Idler Arm Assembly No. 126-0976	10
Main Frame Assembly	12
Caster Tire Assembly	14
Caster Wheel Assembly	16
Roll-Over Protection System Assembly	18
Deck Lift Assembly	20
Deck Strut Assembly	22
Motion Control Assembly	24
LH and RH Motion Control Assembly	26
Control Assembly	28
Rear Tire Assembly	30
Fuel Tank and Vent Hose System Assembly	32
Fuel Tank Assembly (cont.)	34
Engine Assembly	36
Air Cleaner Assembly No. 93-2190	38
Fuel System Assembly	40
Carburetor Assembly	42
Air Intake and Filtration Assembly	44
Ignition and Cooling Fan	46
Crankcase and Crankshaft Assembly	48
Governor Control Assembly	50
Piston and Cylinder Head Assembly	52
Blower Housing Assembly	54
Gasket and Seal Kit	56
Suspension Assembly	58
Seat Assembly	60
Hydraulic Drive Assembly	62
LH Transaxle Assembly	64
RH Transaxle Assembly	66
Electrical Assembly	68
Harness Assembly No. 126-5803	70

Complete Deck Assembly

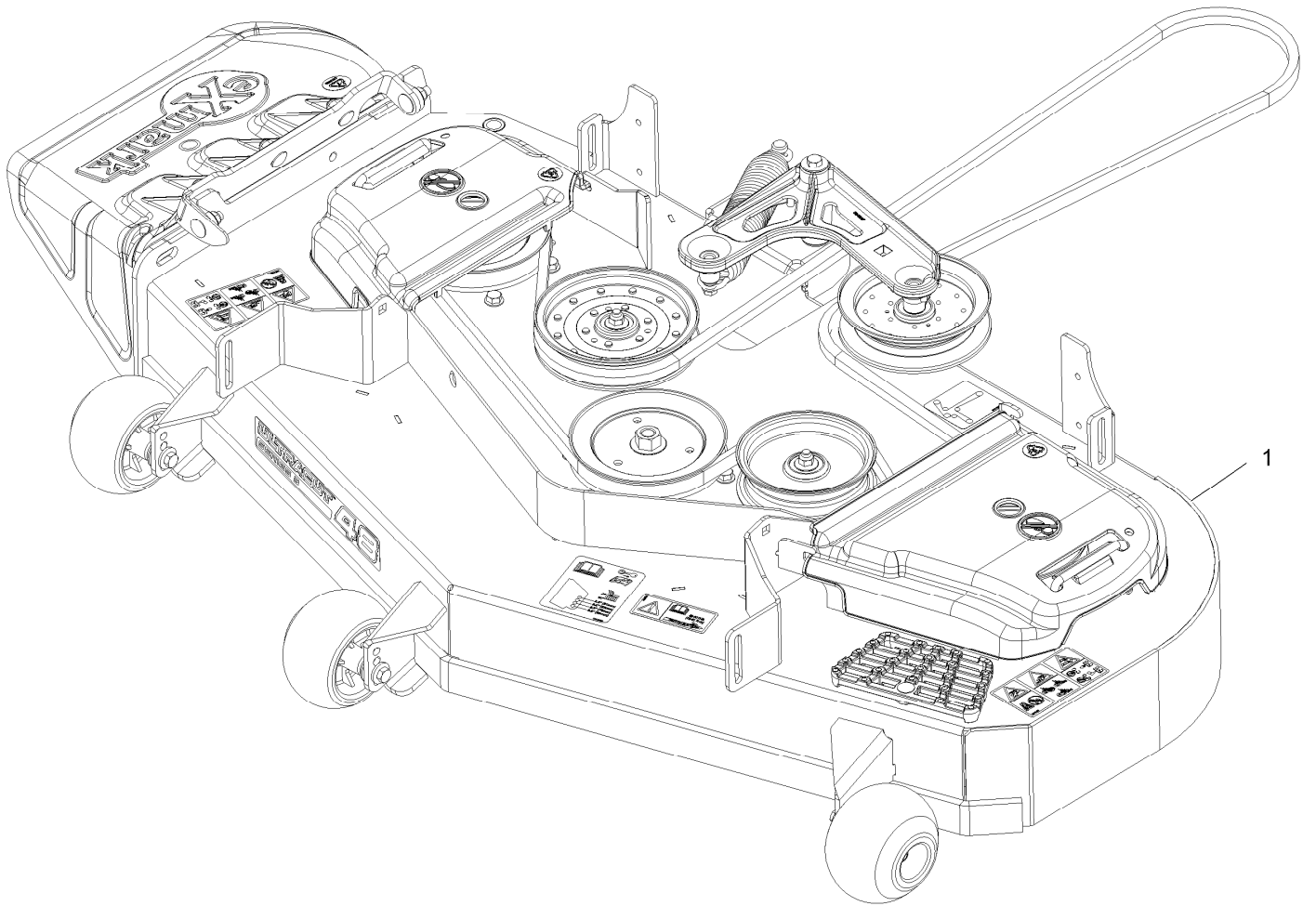

Complete Deck Assembly (continued)

<i>Ref.</i>	<i>Part Number</i>	<i>Qty.</i>	<i>Description</i>
1	126-8036	1	ASM-Deck Complete 483

Deck Assembly

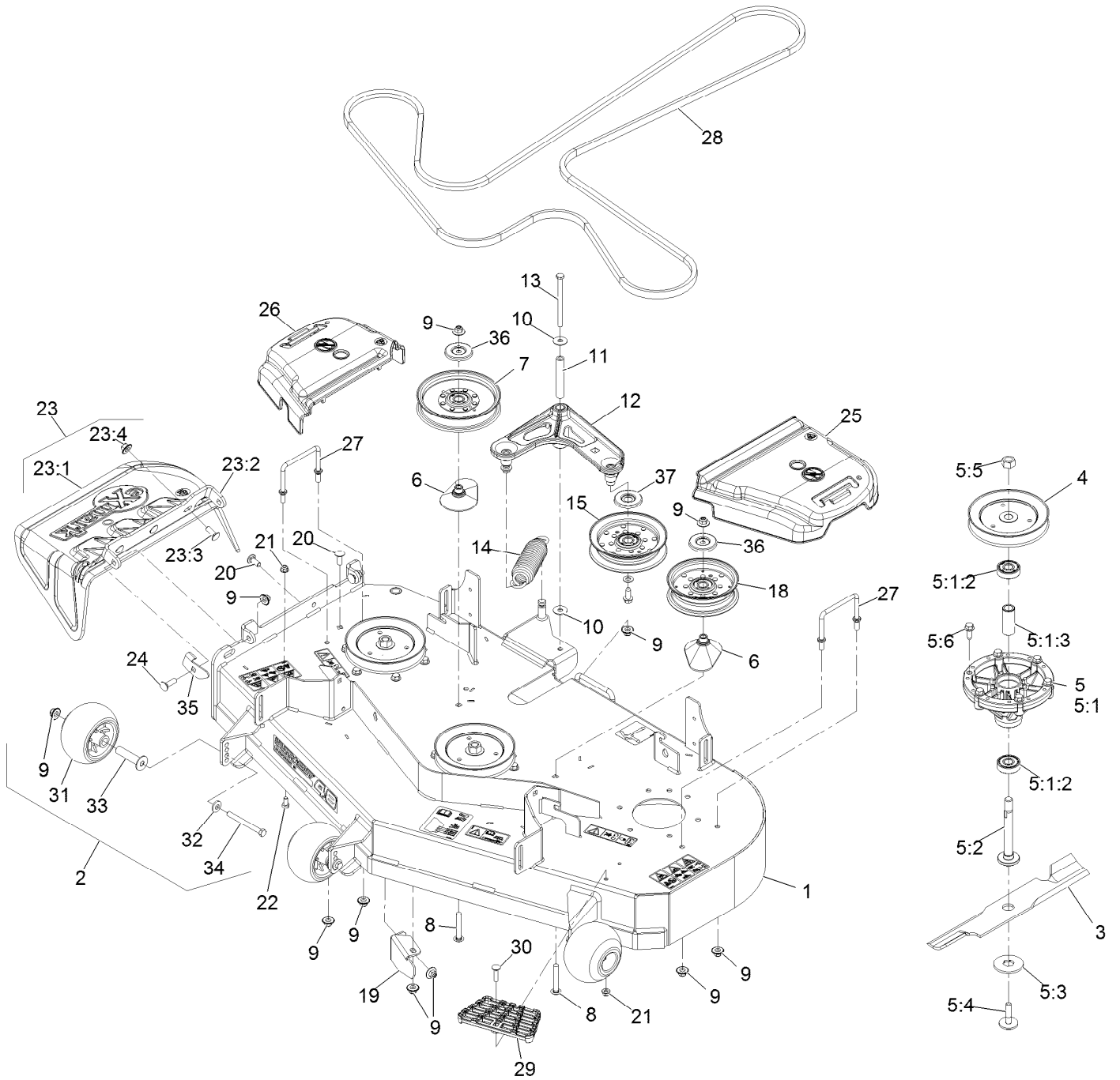

Deck Assembly (continued)

<i>Ref.</i>	<i>Part Number</i>	<i>Qty.</i>	<i>Description</i>	<i>Ref.</i>	<i>Part Number</i>	<i>Qty.</i>	<i>Description</i>
1	126-3575	1	ASM-Deck W/Decals 483	15	126-9196	1	Idler-Pulley, Flat
2	116-9981	3	Kit, Anti-Scalp Roller	18	126-9197	1	Idler-Pulley, Flat 5.00X1.31
3	103-6391	3	Blade, Mulching ♦	19	116-0680-01	1	Baffle, Discharge 483
3	103-6386	3	Blade, Low Lift ●	20	3231-22	2	Bolt-Carriage 3/8-16 X 1
3	103-6381	3	Blade, Solid ●	21	104-8300	2	Nut-Nyloc 5/16-18 Flg
3	103-6401	3	Blade-Notched	22	322-2	1	Screw-HH 5/16-18 X 5/8
3	116-5177	3	Blade-Extreme 2, 16.25" ●	23	109-7188	1	ASM, Discharge Chute
4	116-5043	3	Sheave, Blade Drive 5.90	23:1	109-2738	1	Chute, Discharge
5	126-4630	3	ASM, Cutter Housing Complete	23:2	109-8675-01	1	Bracket, Discharge Chute
5:1	126-4627	1	ASM-Cutter Housing	23:3	3231-22	3	Bolt-Carriage 3/8-16 X 1
5:1:2	116-4004	2	Bearing	23:4	109-6658	3	Nut-Nyloc 3/8-16 Flg
5:1:3	116-4876	1	Spacer-Bearing	24	3231-25	2	Bolt-Carriage 3/8-16 X 1 1/4
5:2	109-7431	1	Spindle-Hex Pilot □	25	109-6936	1	Cover-Belt, LH
5:3	126-4530	1	Washer-Hex Blade Drive	26	109-6935	1	Cover-Belt, RH
5:4	116-0005	1	Bolt-Blade, Sem ■ ○	27	109-6982	2	Wireform-Cover
5:5	3219-6	1	Nut-Hex 5/8-18 ▲	28	126-6626	1	Belt-V
5:6	126-1696	6	Screw-Forming, Thread	29	126-4781-03	1	Step-Deck
6	109-2872	2	Spacer-Pulley	30	3230-3	1	Bolt-Carriage 5/16-18 X 1 1/4
7	126-9189	1	Idler-Pulley, Flat 6.00X1.00	31	103-8415	3	Roller-Anti-Scalp
8	3231-44	2	Bolt-Carriage 3/8-16 X 2 1/2	32	98-5975	3	Washer-Spring Disc 3/8
9	109-6658	14	Nut-Nyloc 3/8-16 Flg	33	116-8131	3	Axle, Roller
10	52-2860	2	Washer	34	116-9362	3	Screw-HH 3/8-16 X 3 3/4 GR 8
11	116-5111	1	Bushing	35	135-0064	1	Stop-Discharge Chute
12	126-0976	1	Idler Arm ASM	36	126-8043	2	Shield-Dust
13	323-38	1	Screw-HH 3/8-16 X 4 3/4	37	126-9195	1	Shield-Guard, Dust
14	116-6317	1	Spring-Extension				

● Optional Equipment

▲ Torque to 75-85 ft-lb

♦ Requires installation of mulch kit for proper mulching. See your Exmark dealer for details.

□ Apply Mobil HTS grease (P/N 103-5217 1.5 oz packet) (or a food-grade anti-seize) to spindle shaft

○ Apply lubricant to threads as needed to prevent seizing. Copper based anti-seize preferable. Grease is an acceptable substitute.

■ Torque to 50-60 ft-lb

Deck W/Decals Assembly

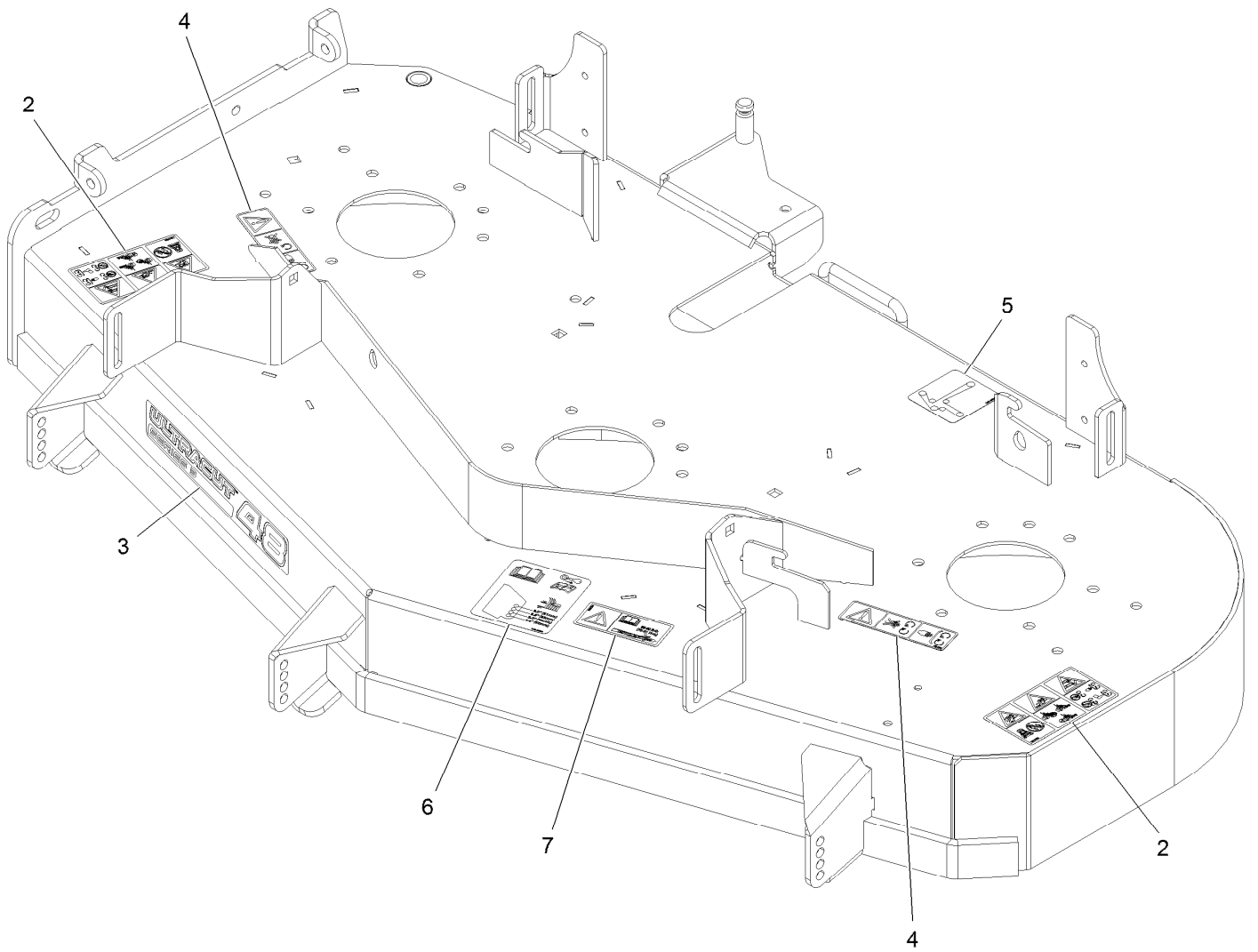

Deck W/Decals Assembly (continued)

<i>Ref.</i>	<i>Part Number</i>	<i>Qty.</i>	<i>Description</i>	<i>Ref.</i>	<i>Part Number</i>	<i>Qty.</i>	<i>Description</i>
2	126-6464	2	Decal-Danger Thrown Objects	5	109-6035	1	Decal-Routing, Belt
3	126-6746	1	Decal-Ultracut 48 Series 3	6	109-6036	1	Decal-Roller, Anti-Scalp
4	112-9028	2	Decal-Cover, Missing	7	116-8283	1	Decal-Bolt Torque

Idler Arm Assembly No. 126-0976

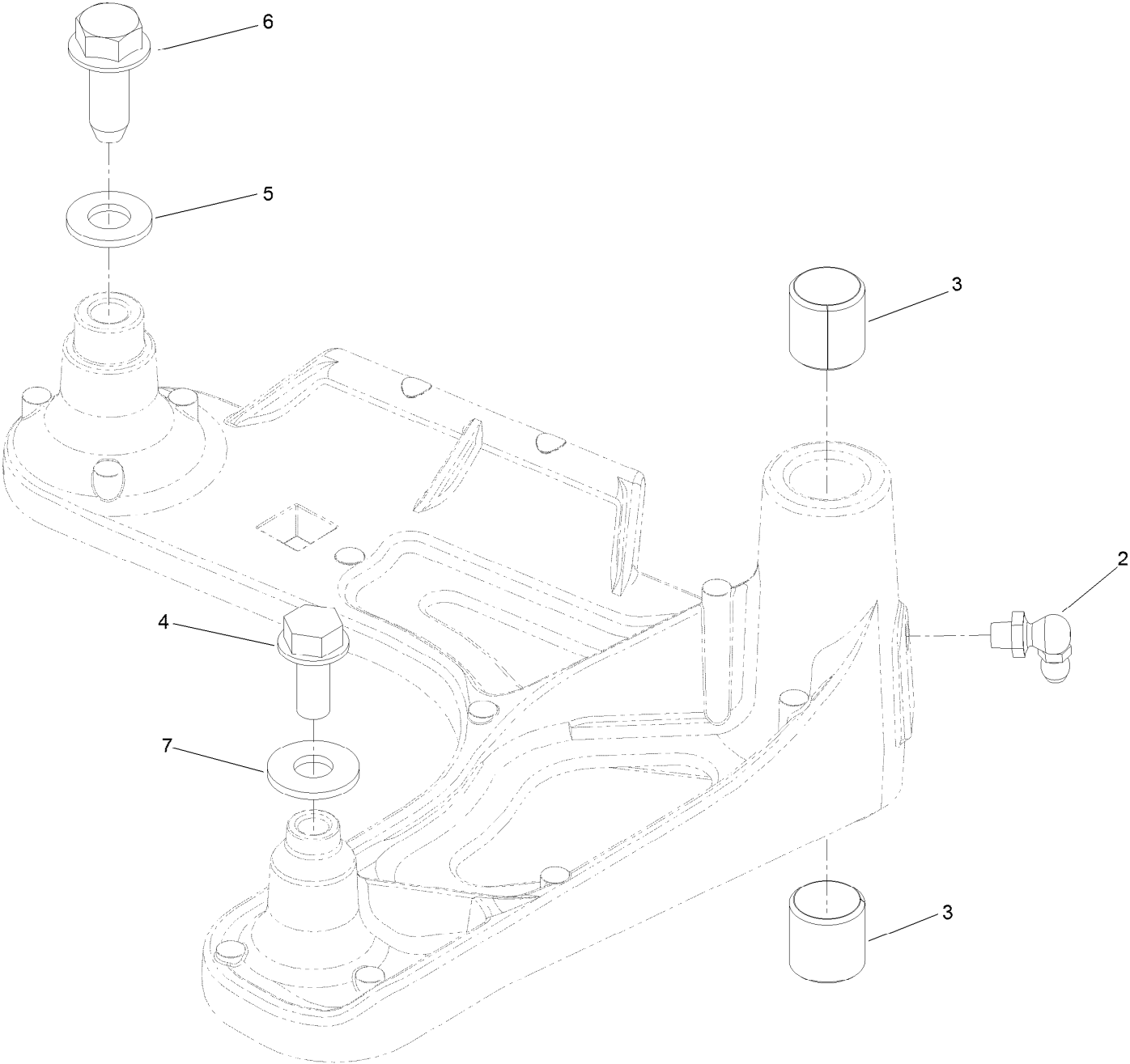

Idler Arm Assembly No. 126-0976 (continued)

<i>Ref.</i>	<i>Part Number</i>	<i>Qty.</i>	<i>Description</i>
2	302-40	1	Fitting-Grease, 90 DEG
3	1-513034	2	Sleeve-Bearing
4	32144-11	1	Screw-HWHTF

<i>Ref.</i>	<i>Part Number</i>	<i>Qty.</i>	<i>Description</i>
5	3256-24	1	Washer-Flat
6	126-1696	1	Screw-Forming, Thread
7	3256-3	1	Washer-Flat

Main Frame Assembly

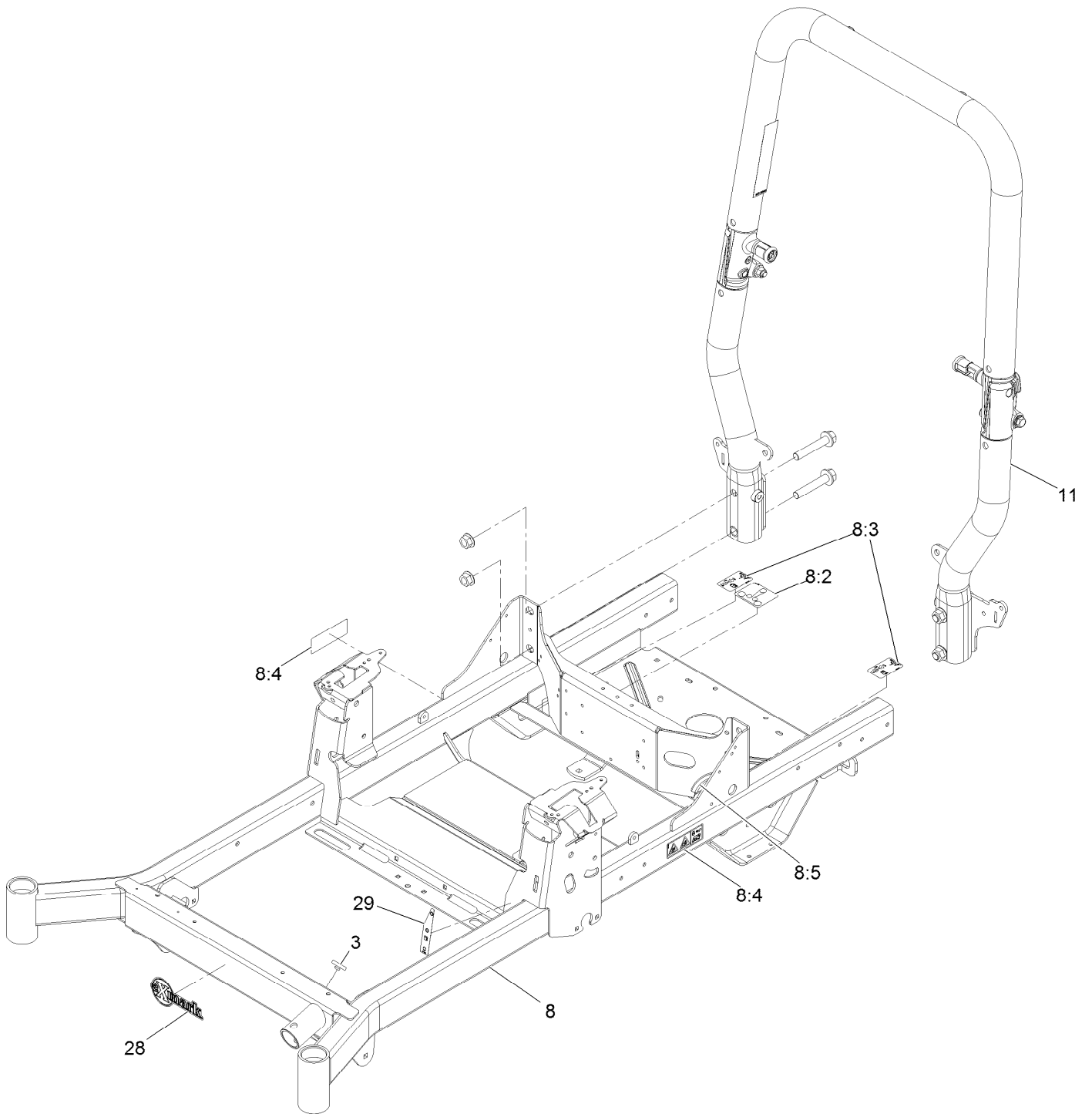

Main Frame Assembly (continued)

<i>Ref.</i>	<i>Part Number</i>	<i>Qty.</i>	<i>Description</i>	<i>Ref.</i>	<i>Part Number</i>	<i>Qty.</i>	<i>Description</i>
3	109-9233	2	Bumper-Push-In, Rubber	8:5	127-6618	1	Strip-Seal
8	136-8983	1	Suspension Frame ASM	11	136-8985	1	ASM-ROPS Tapered
8:2	109-6014	1	Decal-Routing, Belt	28	126-6575	1	Decal-Exmark Logo
8:3	116-8588	2	Decal-Release, Drive	29	136-8992	1	Decal-Fill, Fuel
8:4	126-4363	2	Decal-Warning				

Caster Tire Assembly

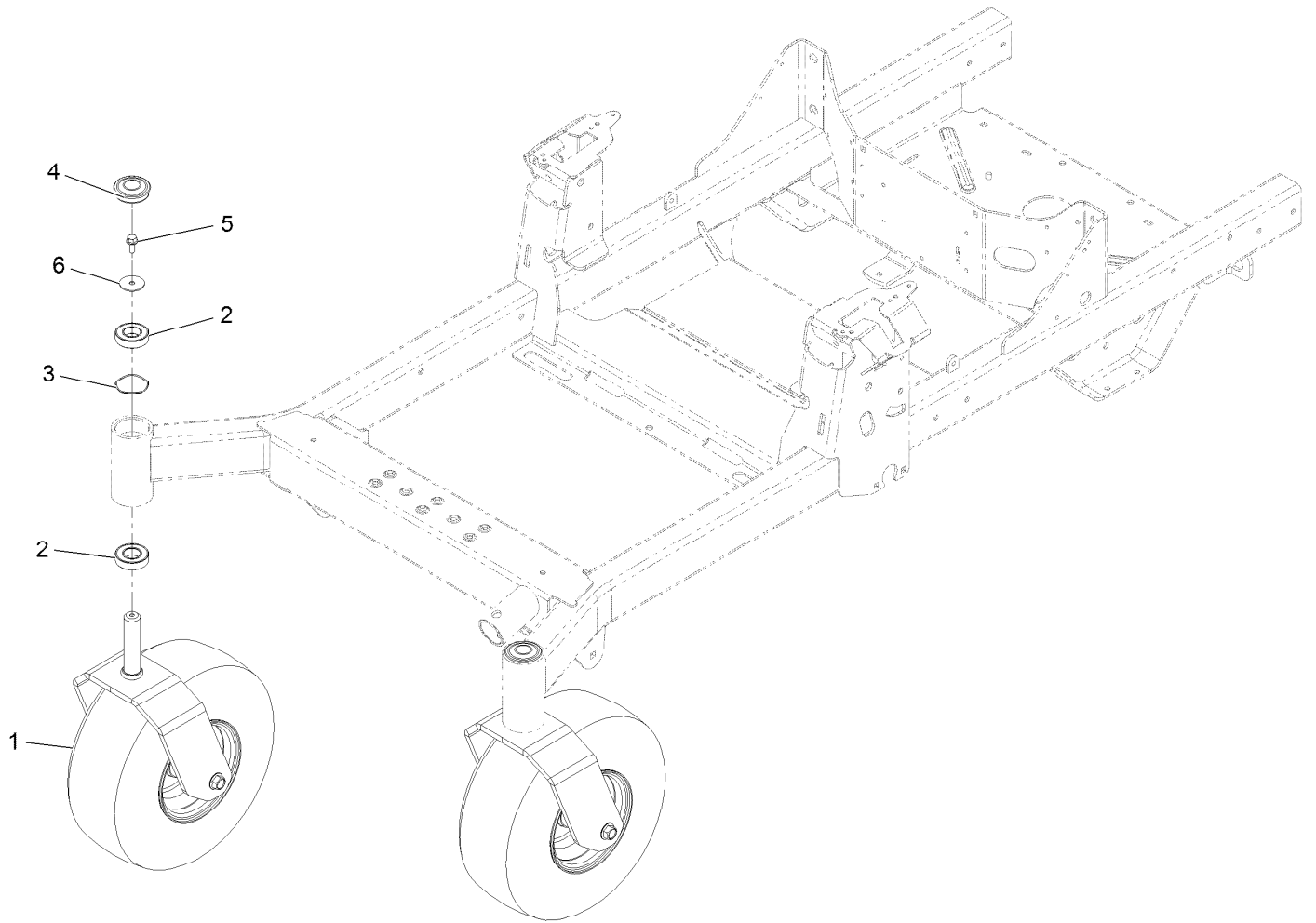

Caster Tire Assembly (continued)

<i>Ref.</i>	<i>Part Number</i>	<i>Qty.</i>	<i>Description</i>	<i>Ref.</i>	<i>Part Number</i>	<i>Qty.</i>	<i>Description</i>
1		2	ASM-Front Caster W/Fork ●	4	116-4348	2	Cap-Grease
2	109-3678	4	Bearing-Ball	5	3234-5	2	Screw-HH Flg 5/16-18 X 3/4
3	126-5897	2	Spring	6	3256-68	2	Washer-Flat

● Not serviced separately

Caster Wheel Assembly

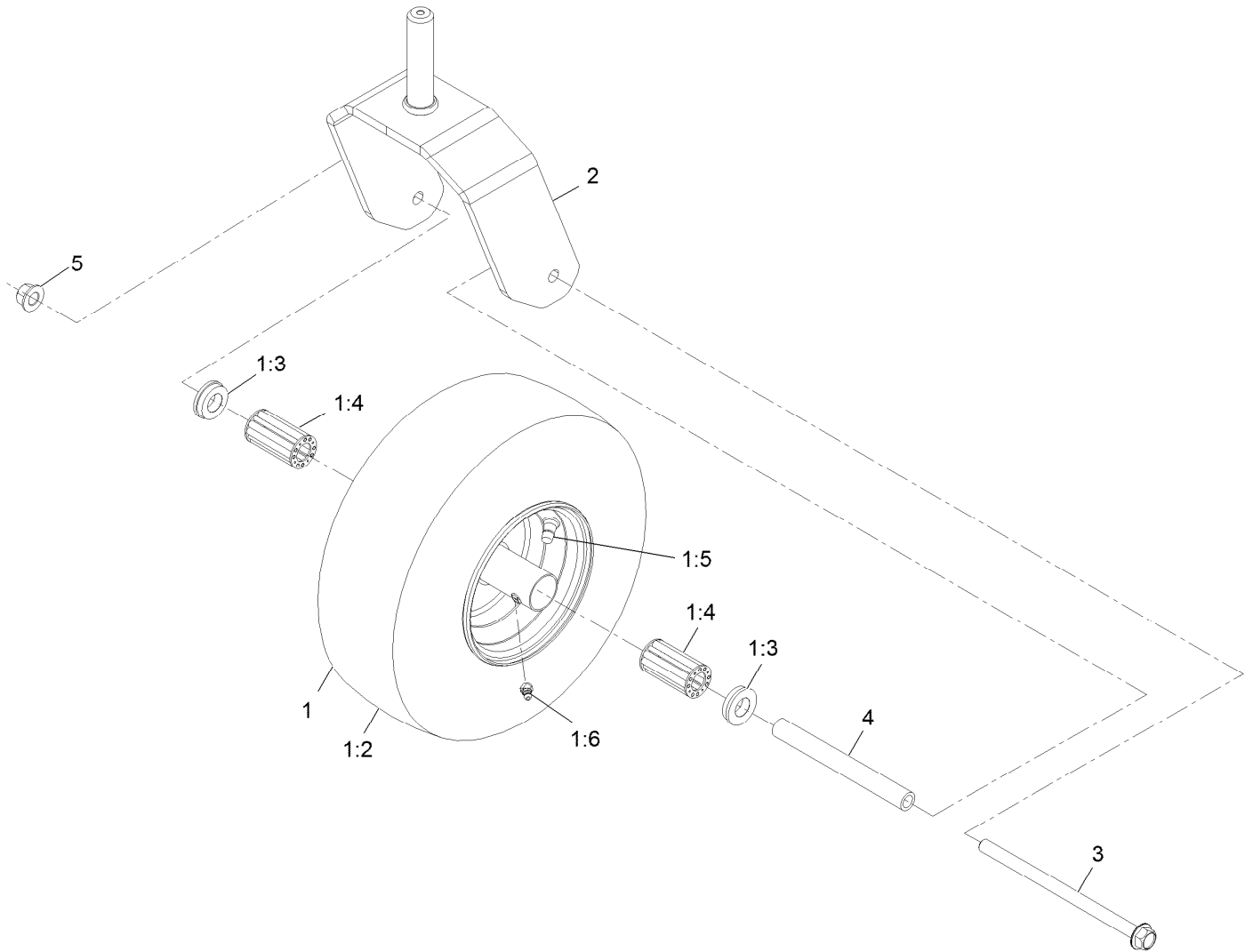

Caster Wheel Assembly (continued)

<i>Ref.</i>	<i>Part Number</i>	<i>Qty.</i>	<i>Description</i>	<i>Ref.</i>	<i>Part Number</i>	<i>Qty.</i>	<i>Description</i>
1	126-3289	1	ASM-Wheel And Tire 13X6.50-6	1:6	120-7125	1	Fitting-Zerk
1:2	126-5959	1	Tire	2	126-4312-01	1	Fork-Caster
1:3	130-0705	2	Bushing-Flange	3	126-5389	1	Screw-HHF
1:4	135-4489	2	Bearing-Roller, Wheel	4	127-0068	1	Spanner-Wheel, Caster
1:5	5108	1	Valve	5	99-5107	1	Nut-Lock 1/2-13

Roll-Over Protection System Assembly

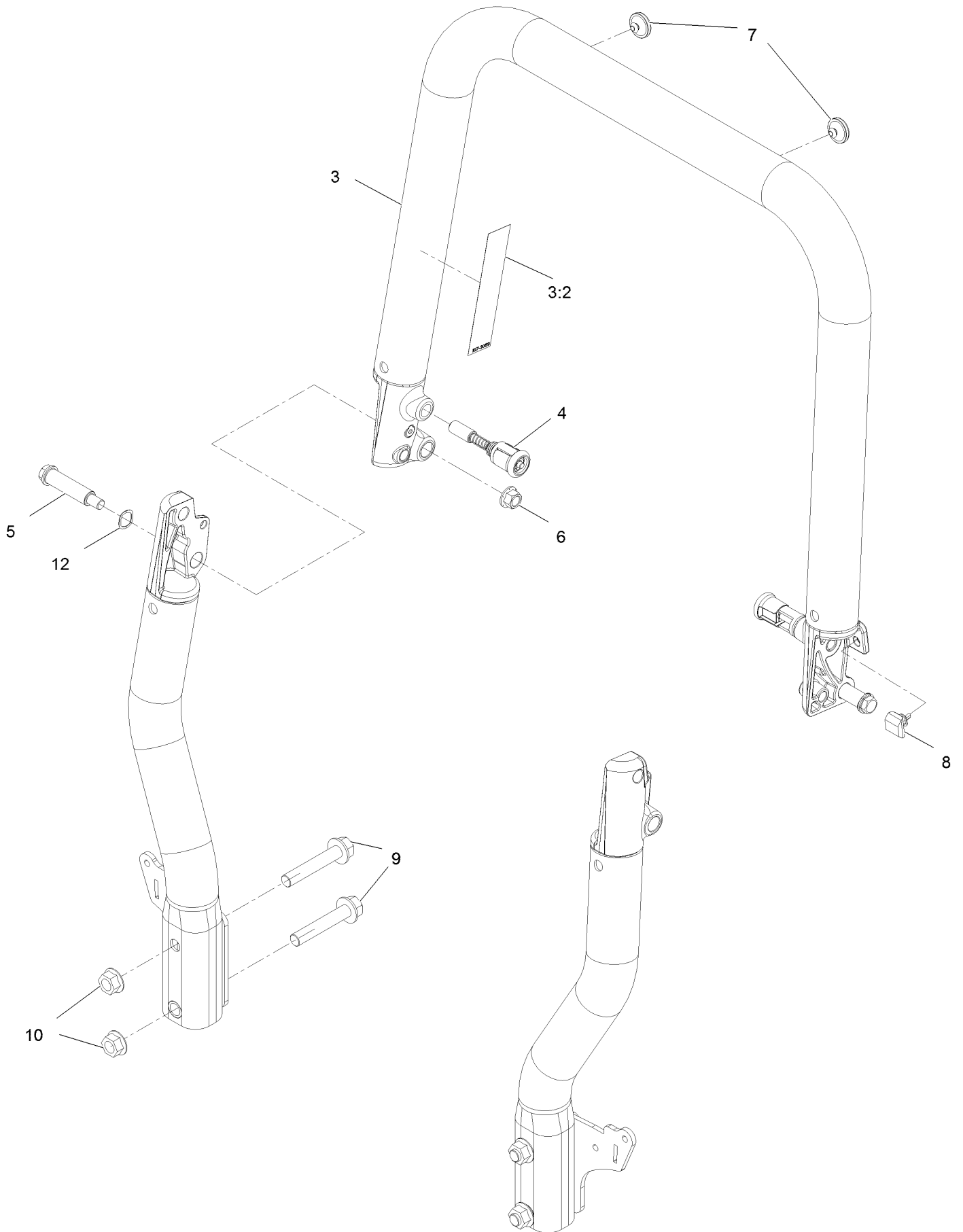

Roll-Over Protection System Assembly (continued)

<i>Ref.</i>	<i>Part Number</i>	<i>Qty.</i>	<i>Description</i>	<i>Ref.</i>	<i>Part Number</i>	<i>Qty.</i>	<i>Description</i>
3	126-7838	1	Top Tube ASM	7	135-0504	2	Bumper-ROPS
3:2	107-3069	1	Decal-Warning	8	126-9966	2	Bumper-ROPS
4	116-0104	2	Pin-Spring	9	126-9488	4	Screw-HHF
5	126-9209	2	Bolt-Shoulder	10	32128-50	4	Nut-Flange
6	99-5107	2	Nut-Lock	12	119-4164	2	Washer-Wave

Deck Lift Assembly

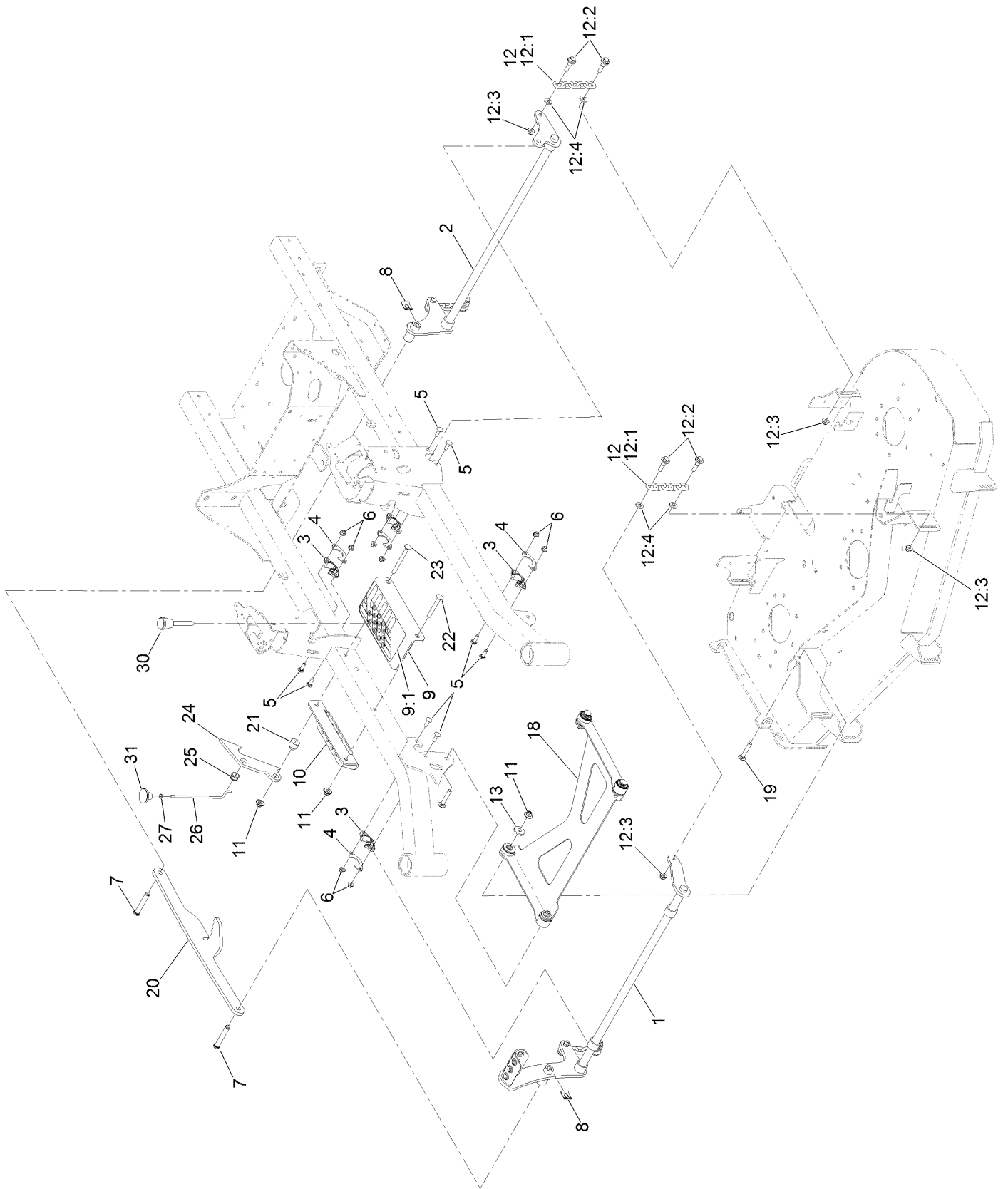

Deck Lift Assembly (continued)

<i>Ref.</i>	<i>Part Number</i>	<i>Qty.</i>	<i>Description</i>	<i>Ref.</i>	<i>Part Number</i>	<i>Qty.</i>	<i>Description</i>
1	126-3342-03	1	Shaft-Lift, Deck	12:3	104-8301	2	Nut-HF, NI
2	126-3343-03	1	Shaft-Lift, Deck (Rear)	12:4	43-0940	2	Spacer
3	115-5065	4	Bushing-Flange	13	1-373034	2	Washer
4	116-2887	4	Gusset-Lift, Deck	18	126-8365	1	Deck Strut ASM
5	3230-22	8	Screw-CARR	19	3231-7	2	Screw-CARR
6	104-8300	8	Nut-HF, NI	20	126-4639-03	1	Link-Lift
7	126-9181	2	Pin-Clevis	21	126-5221	1	Spacer-Stepped
8	95-4064	2	Clip-Pin	22	3231-42	1	Screw-CARR
9	126-4535	1	Bracket ASM	23	135-0313	1	Screw-CARR
9:1	126-4784	1	Decal-HOC	24	126-5222	1	Plate-Lock, Transport
10	126-4640-03	1	Angle-HOC, Lower	25	126-5593	1	Grommet
11	109-6658	4	Nut-Flange, NI	26	126-5223	1	Rod-Lock, Transport
12	126-8877	4	Deck Chain ASM	27	3218-1	1	Nut-Jam
12:1	1-633447	1	Chain-Lift, Deck	30	126-5401	1	Pin-HOC
12:2	130-0742	2	Bolt-Shoulder	31	126-7019	1	Knob

Deck Strut Assembly



Deck Strut Assembly (continued)

<i>Ref.</i>	<i>Part Number</i>	<i>Qty.</i>	<i>Description</i>	<i>Ref.</i>	<i>Part Number</i>	<i>Qty.</i>	<i>Description</i>
2	126-8360	4	Bushing-Rubber, Suspension	4	3231-7	2	Screw-CARR
3	108-6544	4	Spacer	5	2844	2	Washer
				6	104-8301	2	Nut-HF, NI

Motion Control Assembly

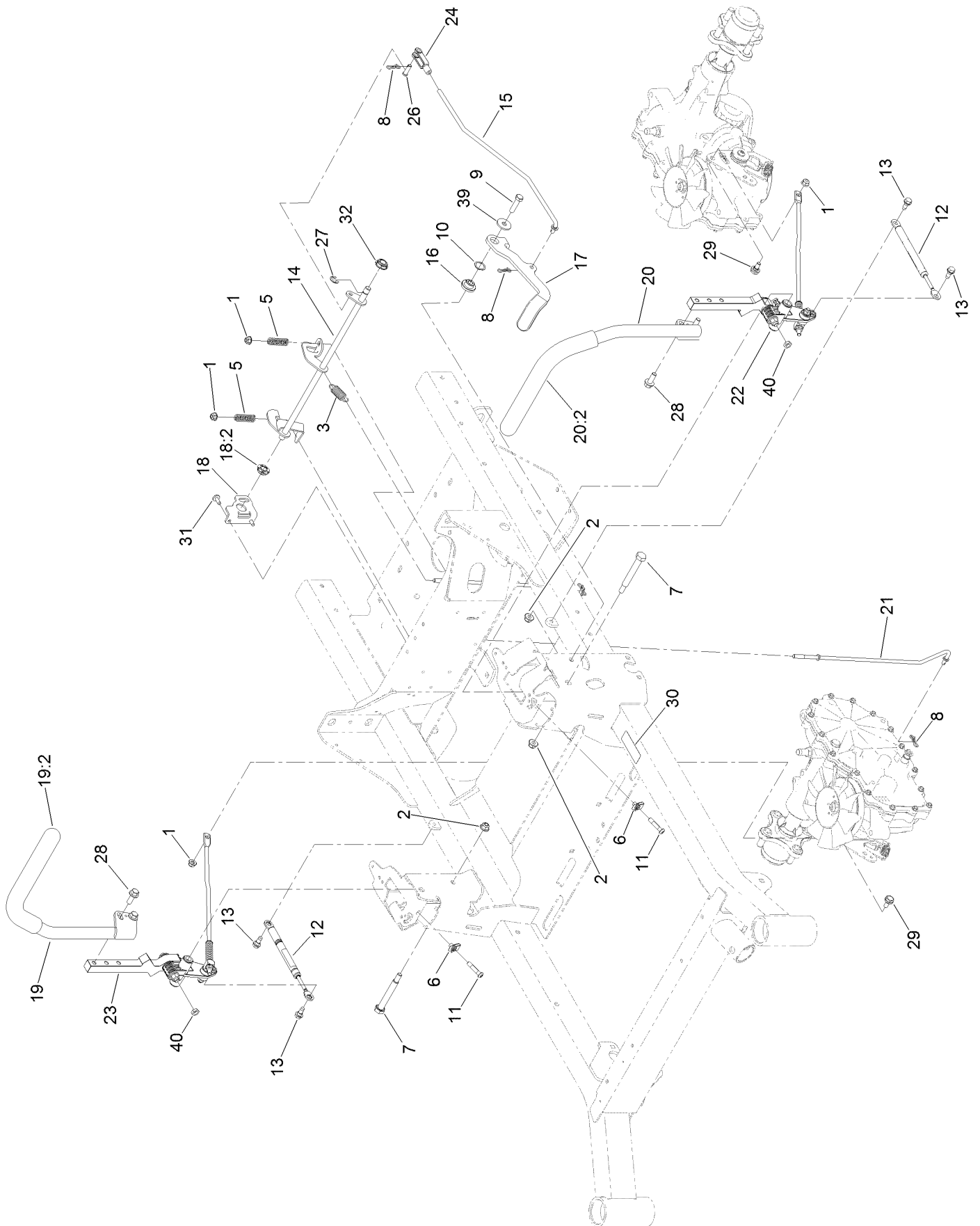

Motion Control Assembly (continued)

<i>Ref.</i>	<i>Part Number</i>	<i>Qty.</i>	<i>Description</i>	<i>Ref.</i>	<i>Part Number</i>	<i>Qty.</i>	<i>Description</i>
1	104-8300	4	Nut-HF, NI	19	136-1725	1	RH Control Handle ASM
2	104-8301	3	Nut-HF, NI	19:2	126-7359	1	Grip
3	107-1045	1	Spring-Extension	20	136-1728	1	LH Control Handle ASM
5	109-7694	2	Spring-Compression	20:2	126-7359	1	Grip
6	112-3306	2	Nut	21	126-7217	2	Linkage-Brake, Lower
7	115-5099	2	Bolt-Pivot	22		1	LH Motion Control ASM ●
8	119-1415	4	Pin-Cotter, Locking	23		1	RH Motion Control ASM ●
9	323-8	1	Screw-HH	24	1-303105	1	Yoke-Adjustable
10	119-4164	1	Washer-Wave	26	1-808280	1	Pin-Clevis
11	126-4299	2	Screw-HSBH	27	32120-47	1	Ring-Retaining, External
12	126-4322	2	Damper	28	3234-42	4	Screw-HHF
13	126-4424	4	Screw-Shoulder	29	37-8771	2	Bolt-Shoulder
14	126-5813	1	Shaft-Brake	30	115-9625	1	Decal-Brake, Parking
15	126-5819	1	Linkage-Brake, Upper	31	126-6266	2	Screw-Torx
16	126-5989	1	Pivot-Flange	32	126-5820	1	Bearing-Spherical
17	126-9490	1	Lever-Brake (With Grip)	39	2844	1	Washer
18	126-6456	1	Bracket-Brake	40	3218-3	2	Nut-Jam
18:2	126-5820	1	Bearing-Spherical				

● Not serviced separately

LH and RH Motion Control Assembly

WASHER ORIENTATION

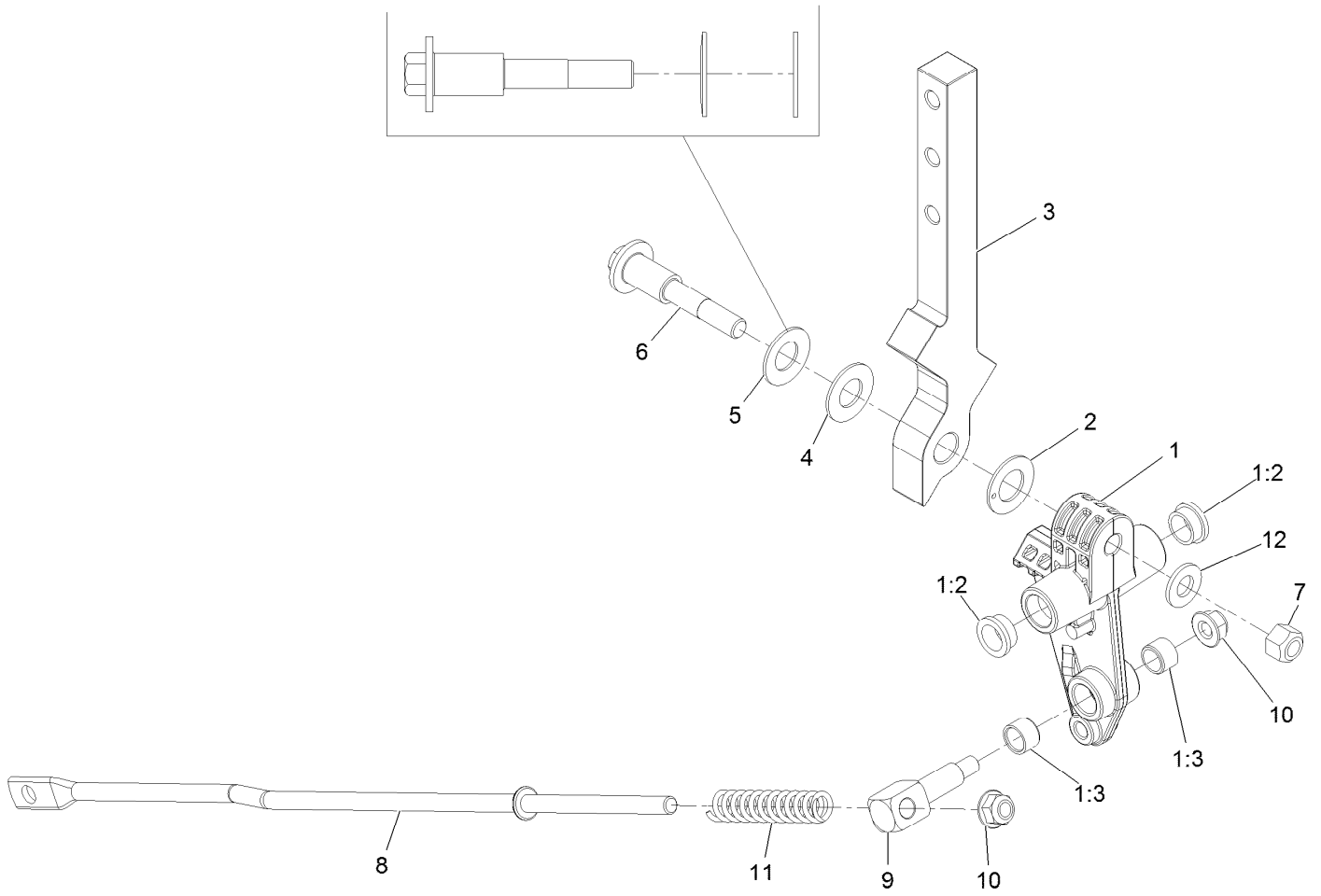

LH and RH Motion Control Assembly (continued)

<i>Ref.</i>	<i>Part Number</i>	<i>Qty.</i>	<i>Description</i>	<i>Ref.</i>	<i>Part Number</i>	<i>Qty.</i>	<i>Description</i>
1	126-3773	1	Control Arm ASM	6	117-1198	1	Bolt-Pivot
1:2	126-8909	2	Bushing	7	32152-2	1	Nut-Hex 3/8-16 Lock
1:3	1-413152	2	Bushing-Sleeve	8	126-5435	1	Link-Control
2	126-7296	1	Washer-Friction	9	126-5434	1	Swivel
3	126-8182	1	Arm-Control	10	104-8300	2	Nut-Nyloc 5/16-18 Flg
4	117-1240	1	Washer	11	126-8195	1	Spring-Return, Neutral
5	119-8925	1	Washer-Belleville	12	3256-24	1	Washer-3/8 SAE

Control Assembly

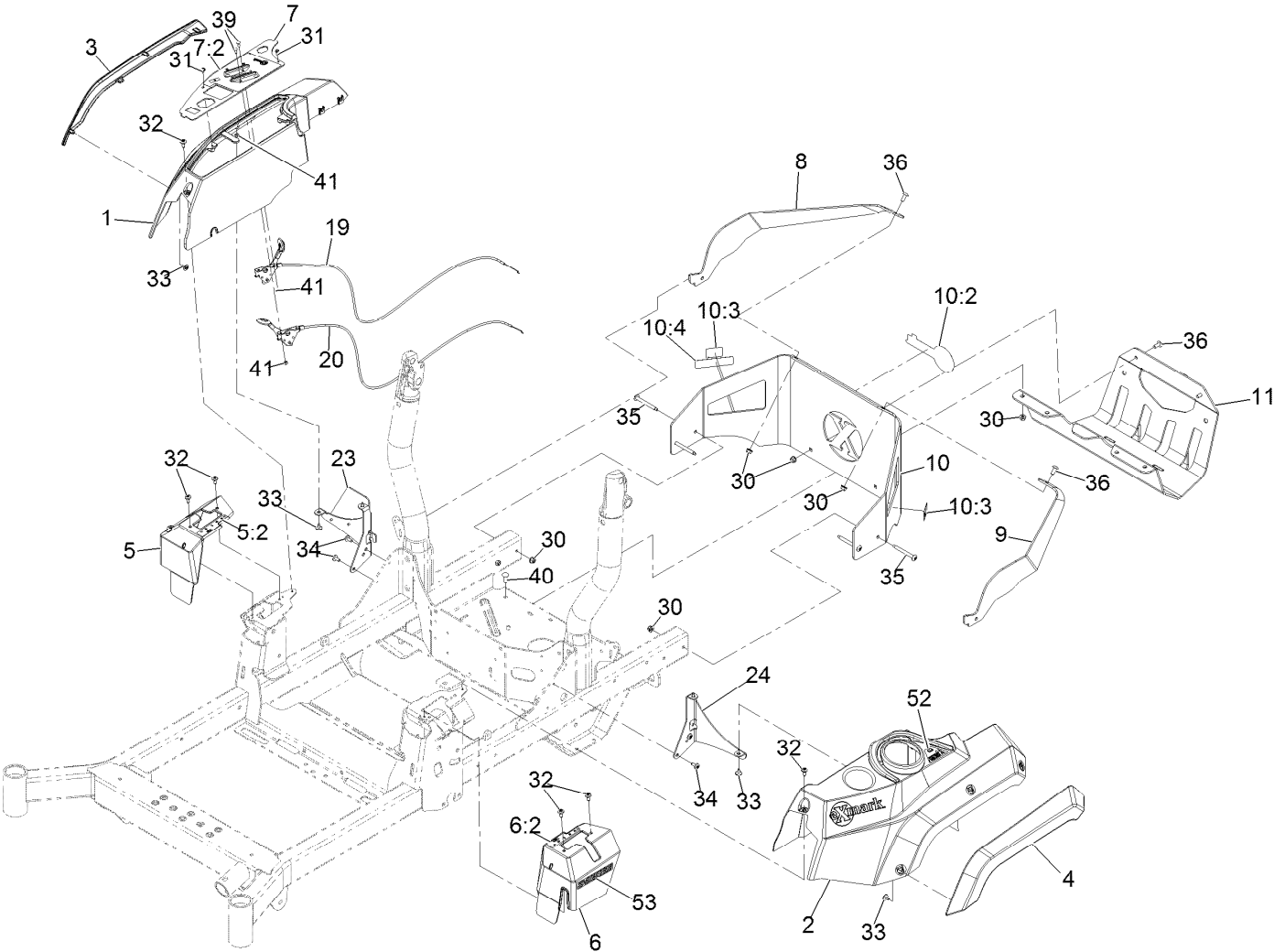

Control Assembly (continued)

<i>Ref.</i>	<i>Part Number</i>	<i>Qty.</i>	<i>Description</i>	<i>Ref.</i>	<i>Part Number</i>	<i>Qty.</i>	<i>Description</i>
1	126-4959	1	Console-Exmark, RH	24	126-5532-03	1	Bracket-Console, LH
2	126-4960	1	Console, LH	30	104-8300	10	Nut-Nyloc 5/16-18 Flg
3	126-4741	1	Fender-RH	31	117-5036	2	Screw-HWH #10-14 X 1/2
4	126-4742	1	Fender-LH	32	120-7950	6	Screw-1/4-20 X 1/2 Tf Torx Plus
5	126-7371	1	Cover-Control, Motion (RH)	33	126-5544	10	Screw-HWH #10-14 X 1/2 Torx
5:2	126-6183	1	Decal-Control, Motion (RH)	34	126-6266	4	Screw-1/4-20 X .65 Torx Plus
6	126-7372	1	Cover-Control, Motion (LH)	35	126-6267	4	Screw-Truss HD 5/16-18 X 2 3/4 Torx Plus
6:2	126-6194	1	Decal-Control, Motion (LH)	36	126-6268	4	Screw-Truss HD 5/16-18 X 3/4 Torx Plus
7	126-7789	1	Ctrl Panel ASM W/Decal	39	1-807513	4	Bolt-Carriage #10-24 X 1/2
7:2	126-6570	1	Decal-Control Panel	40	3230-22	2	Bolt-Carriage 5/16-18 X 1 Sp
8	126-6015-03	1	Support-Upper, RH	41	3296-2	4	Nut-Nyloc #10-24
9	126-6016-03	1	Support-Upper, LH	52	126-9939	1	Decal-Fill, Fuel
10	126-7802	1	Rear Guard ASM	53	126-9296	2	Decal-S-Series
10:2	126-6965	1	Decal-Exmark Logo				
10:3	106-5517	2	Decal-Warning				
10:4	117-2718	1	Decal-Arrester, Spark				
11	126-7664-03	1	Guard-Muffler				
19	126-6945	1	Cable-Control, Choke				
20	126-6944	1	Cable-Control, Throttle				
23	126-9945	1	Support-Console, RH				

Rear Tire Assembly

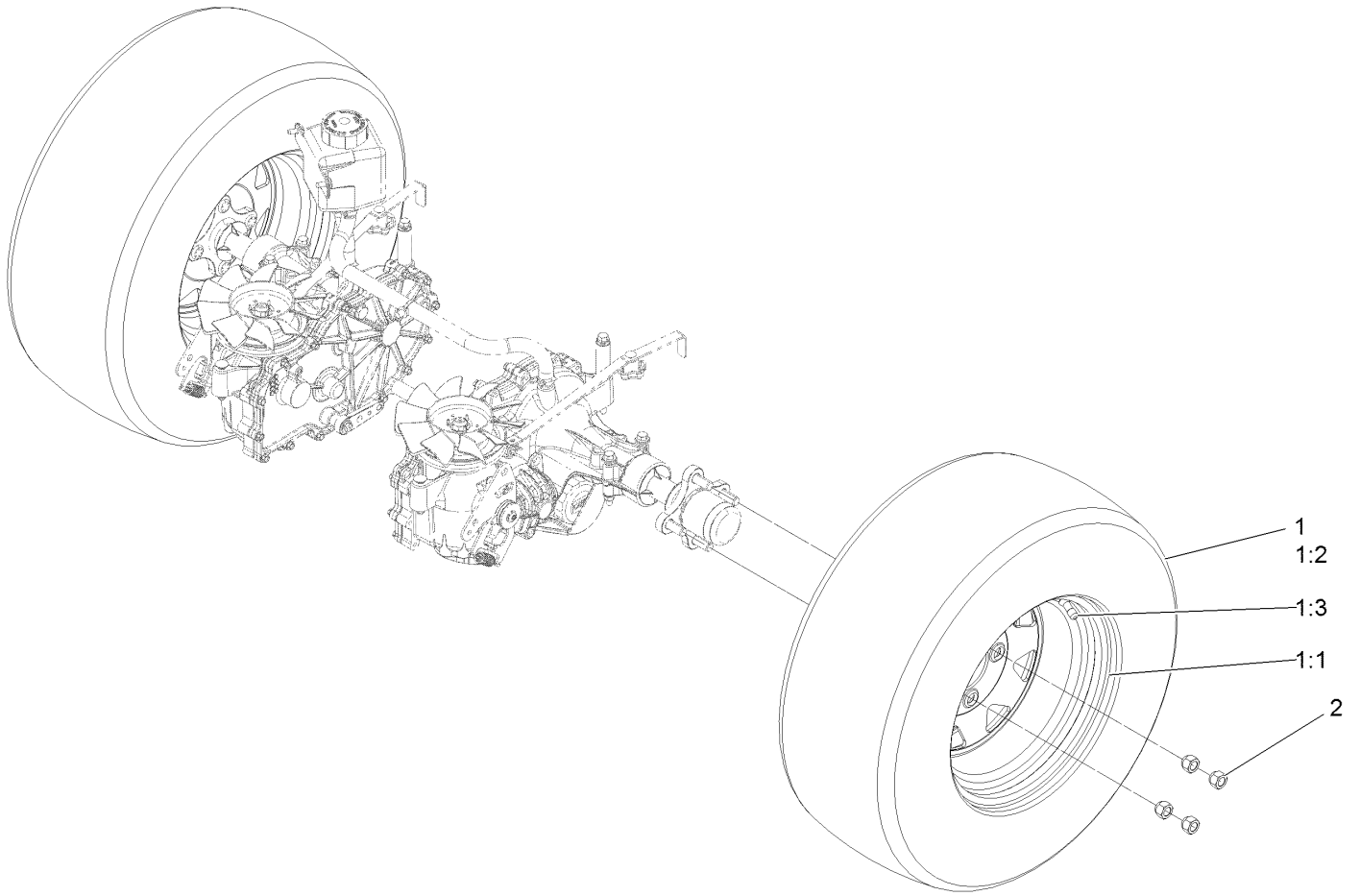

Rear Tire Assembly (continued)

<i>Ref.</i>	<i>Part Number</i>	<i>Qty.</i>	<i>Description</i>
1	126-3284	2	Wheel And Tire ASM
1:1	126-9073	1	Wheel
1:2	126-3288	1	Tire

<i>Ref.</i>	<i>Part Number</i>	<i>Qty.</i>	<i>Description</i>
1:3	232-27	1	Stem-Valve
2	242-50	8	Nut-Lug 1/2-20

Fuel Tank and Vent Hose System Assembly

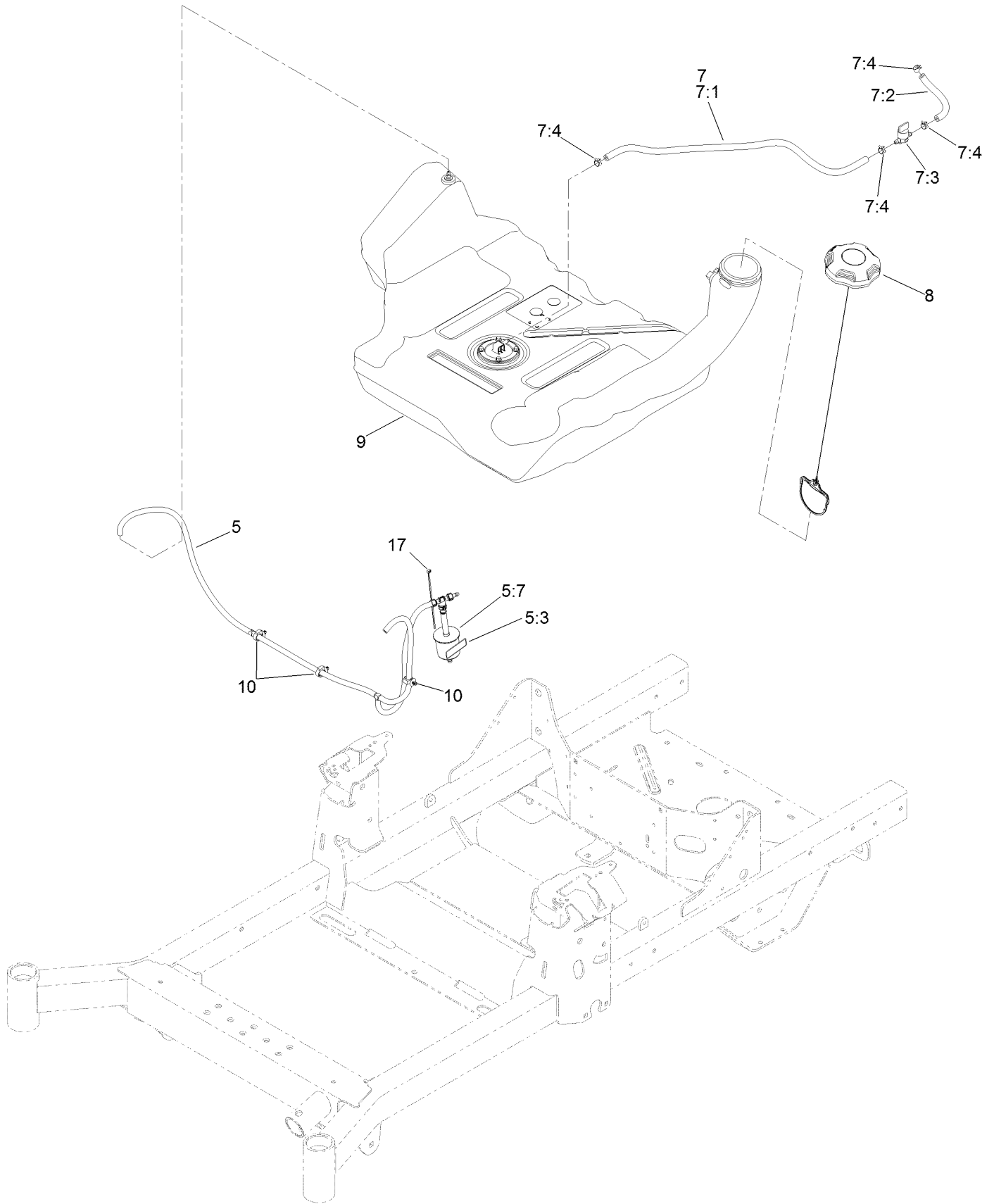

Fuel Tank and Vent Hose System Assembly (continued)

<i>Ref.</i>	<i>Part Number</i>	<i>Qty.</i>	<i>Description</i>	<i>Ref.</i>	<i>Part Number</i>	<i>Qty.</i>	<i>Description</i>
5	126-8738	1	Vent Hose ASM	7:3	1-603770	1	Valve-Fuel
5:3	116-4769	1	Decal-Filter, Emissions	7:4	2412-98	4	Clamp-Hose
5:7	120-2235	1	Filter-Fuel	8	126-4723	1	Cap-Fuel
7	126-8740	1	Fuel Hose ASM	9	126-4724	1	Tank-Fuel
7:1	109-0302	1	Hose-Fuel	10	126-5523	3	Clip
7:2	109-0678	1	Hose-Fuel	17	1-303287	1	Tie-Cable

Fuel Tank Assembly (cont.)

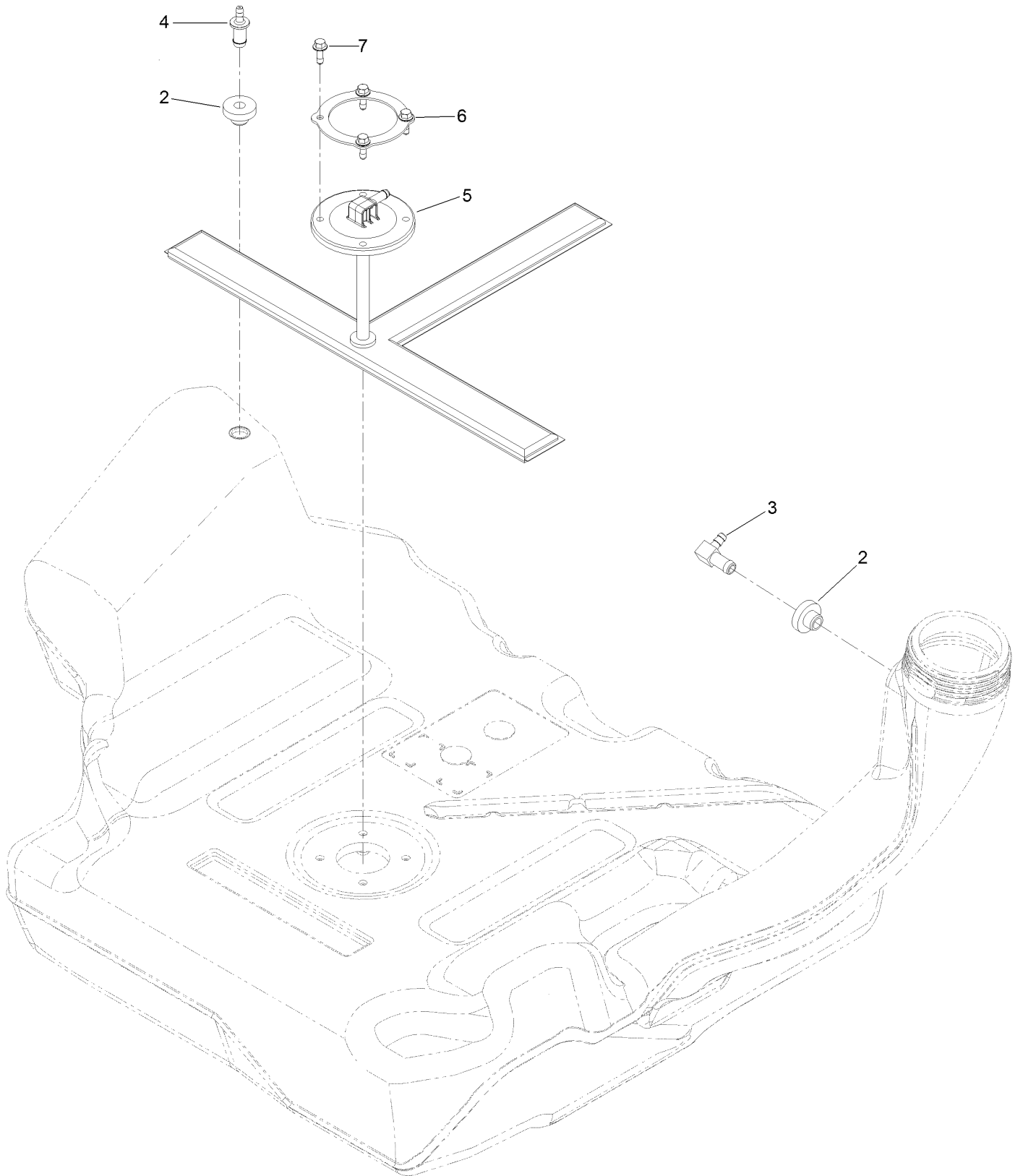

Fuel Tank Assembly (cont.) (continued)

<i>Ref.</i>	<i>Part Number</i>	<i>Qty.</i>	<i>Description</i>	<i>Ref.</i>	<i>Part Number</i>	<i>Qty.</i>	<i>Description</i>
2	46-6560	2	Bushing	5	126-5528	1	Pickup-Fuel
3	126-9057	1	Fitting-90 DEG	6	126-5527	1	Ring-Retainer
4	116-4630	1	Fitting-Orifice, Straight	7	126-5525	4	Bolt

Engine Assembly

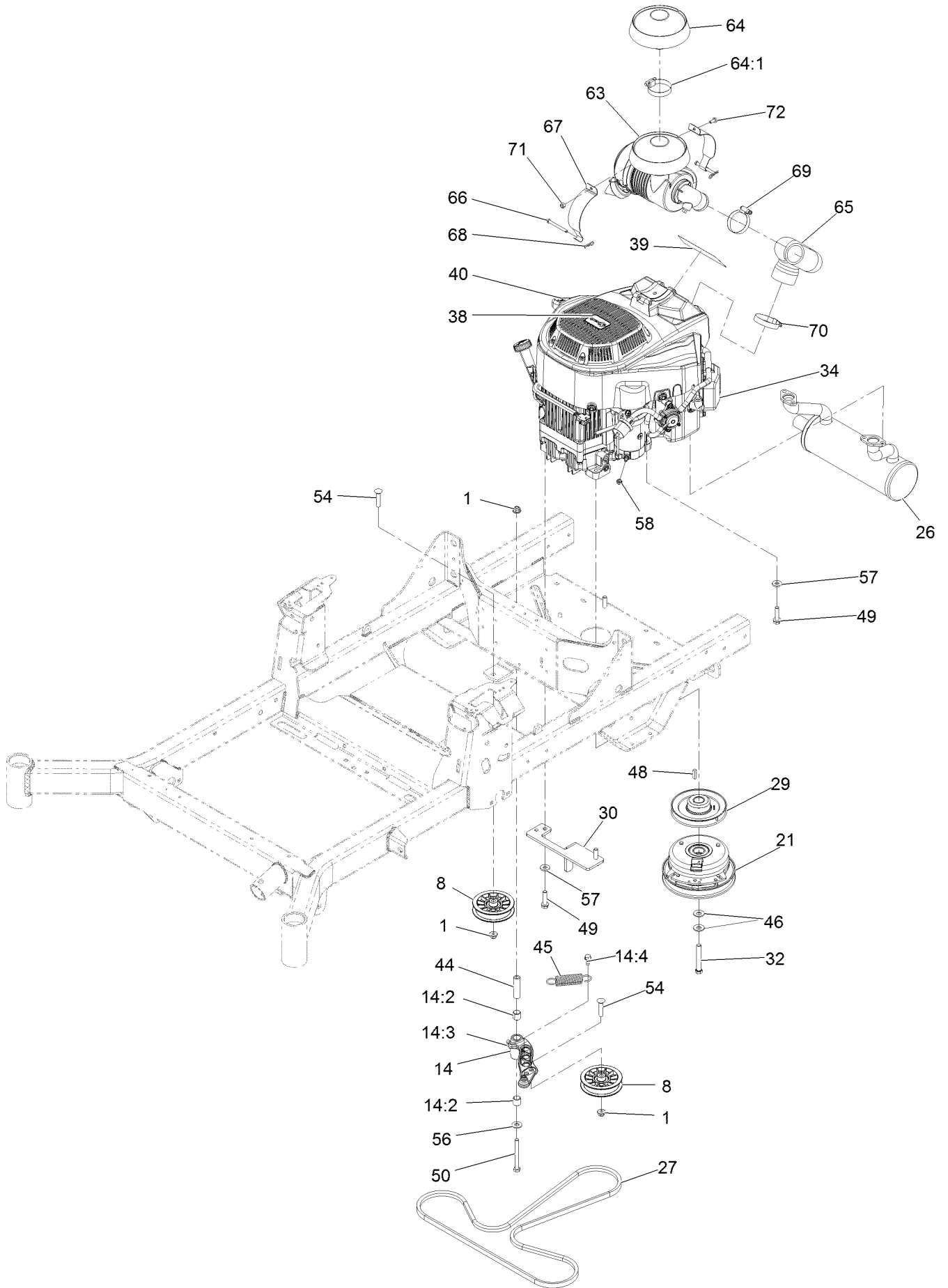

Engine Assembly (continued)

<i>Ref.</i>	<i>Part Number</i>	<i>Qty.</i>	<i>Description</i>	<i>Ref.</i>	<i>Part Number</i>	<i>Qty.</i>	<i>Description</i>
1	104-8301	3	Nut-Nyloc 3/8-16 Flg	46	1-603610	2	Washer-Spring Disc 7/16
8	116-2456	2	Pulley-Flat	48	1-807259	1	Key-Machine 1/4 X 1/4 X 1
14	126-0973	1	Idler Arm ASM	49	32144-102	4	Screw-HWH 3/8-16 X 1 1/2 Taptite
14:2	1-513034	2	Sleeve-Bearing	50	323-15	1	Screw-HH 3/8-16 X 3 1/2
14:3	302-40	1	Zerk-90° 1/4-28	54	3231-29	2	Bolt-Carriage 3/8-16 X 1 3/4
14:4	32144-11	1	Screw-HWH 5/16-18 X 3/4 Tf	56	3256-4	1	Washer-3/8 Std
21	126-4323	1	Clutch 1.00	57	98-5975	4	Washer-Spring Disc 3/8
26	126-5864	1	Muffler	58	33003-00	1	Nut-Hex M6-1 Flg
27	126-5993	1	Belt-V	63	93-2190	1	Air Cleaner ASM
29	136-9012	1	Sheave-Engine	64	136-7859	1	Rain Cap Kit
30	126-6687-03	1	Anchor-Clutch	64:1	1-643009	1	Clamp-Hose
32	126-7198	1	Screw-HH 7/16-20 X 3 W/Loctite ●	65	136-9242	1	Hose-Intake
34	136-7823	1	Engine-2P77F-HD	66	137-2011	2	Pin-Clevis
38	131-1078	1	Decal	67	136-9243	2	Strap-Canister, Air
39	135-2516	1	Decal - Air Canister Mount	68	1-806003	2	Hairpin-Cotter
40	131-1097	1	Decal-Drain, Oil	69	1-643009	1	Clamp-Hose
44	1-603384	1	Bushing-Pivot, Idler	70	2412-130	1	Clamp-Hose
45	1-603402	1	Spring-Extension	71	137-3088	1	Nut-Hex
				72	137-3041	1	Screw-HH

● Use Pro-Lock, Nut Type (P/N 1-840022, .5ml tube) on threads.

Air Cleaner Assembly No. 93-2190

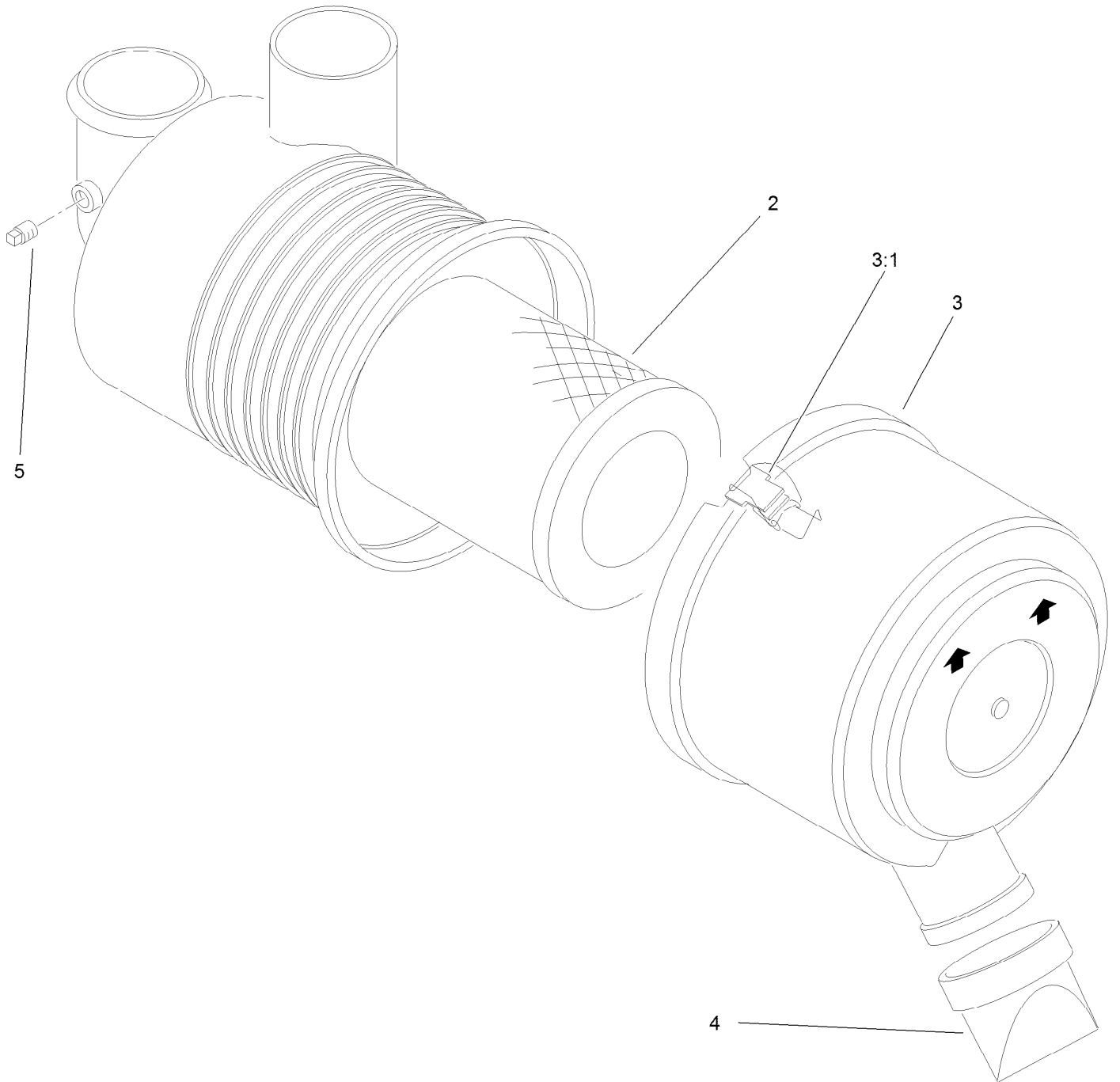

Air Cleaner Assembly No. 93-2190 (continued)

<i>Ref.</i>	<i>Part Number</i>	<i>Qty.</i>	<i>Description</i>	<i>Ref.</i>	<i>Part Number</i>	<i>Qty.</i>	<i>Description</i>
2	108-3811	1	Filter-Air	4	87-9400	1	Valve-Vacuator
3	94-3652	1	Cover ASM	5	285-17	1	Plug-Pipe
3:1	1-643283	2	Latch-Cleaner, Air				

Fuel System Assembly

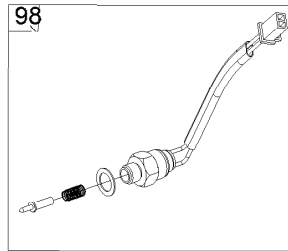
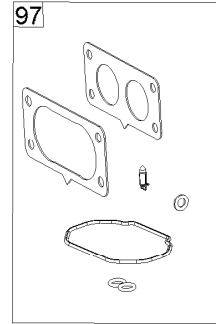
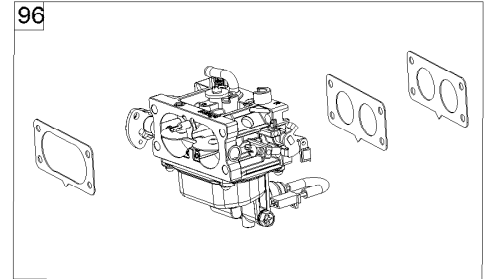
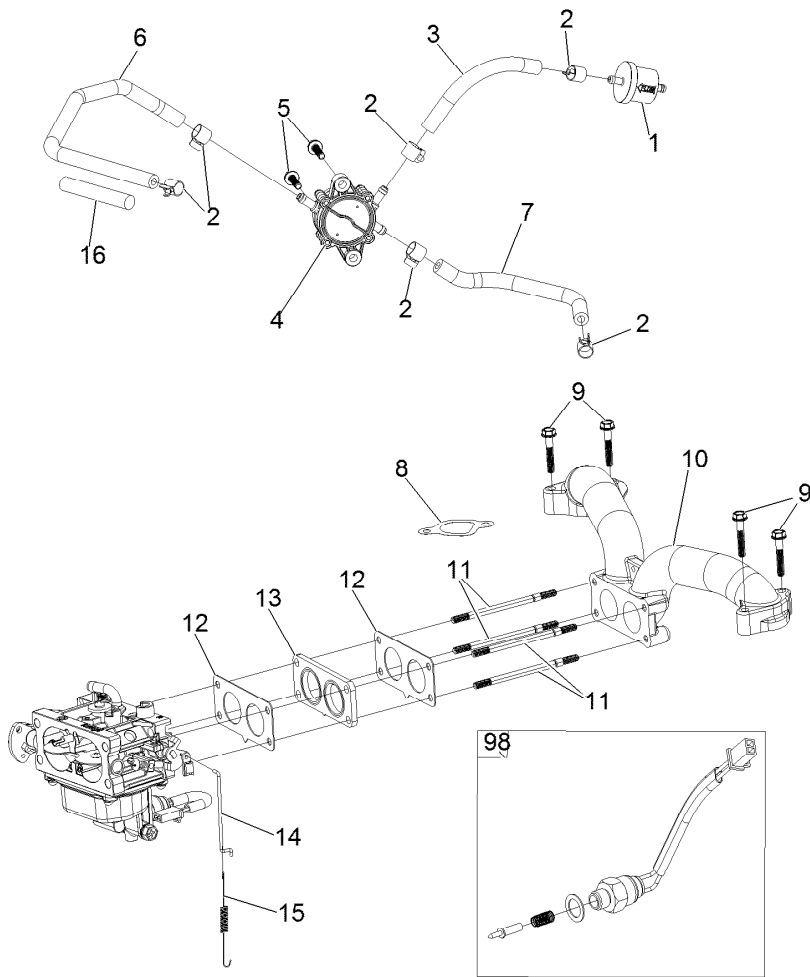

Fuel System Assembly (continued)

<i>Ref.</i>	<i>Part Number</i>	<i>Qty.</i>	<i>Description</i>	<i>Ref.</i>	<i>Part Number</i>	<i>Qty.</i>	<i>Description</i>
1	133-1563	1	Filter-Fuel	12	127-9246	2	Gasket-Carburetor
2	120-4251	6	Clamp-Fuel Line	13	127-9247	1	Insulator-Carburetor
3	120-4371	1	Line-Fuel	14	133-9963	1	Linkage-Throttle
4	127-9206	1	Pump-Fuel	15	133-9964	1	Spring-Return, Throttle
5	120-4225	2	Screw-HHF	16	127-9355	1	Sleeve-Fuel Line Protector
6	127-9205	1	Hose-Fuel	96	136-7842	1	Carburetor Replacement Kit ASM
7	127-9207	1	Hose-Fuel	97	127-9290	1	Carburetor Repair Kit
8	127-9230	2	Gasket-Intake	98	127-9292	1	Solenoid Kit
9	120-4284	4	Screw-HHF	99	136-7838	1	High Altitude Kit ●
10	127-9244	1	Manifold-Intake				
11	127-9245	4	Stud				

● Not illustrated

Carburetor Assembly

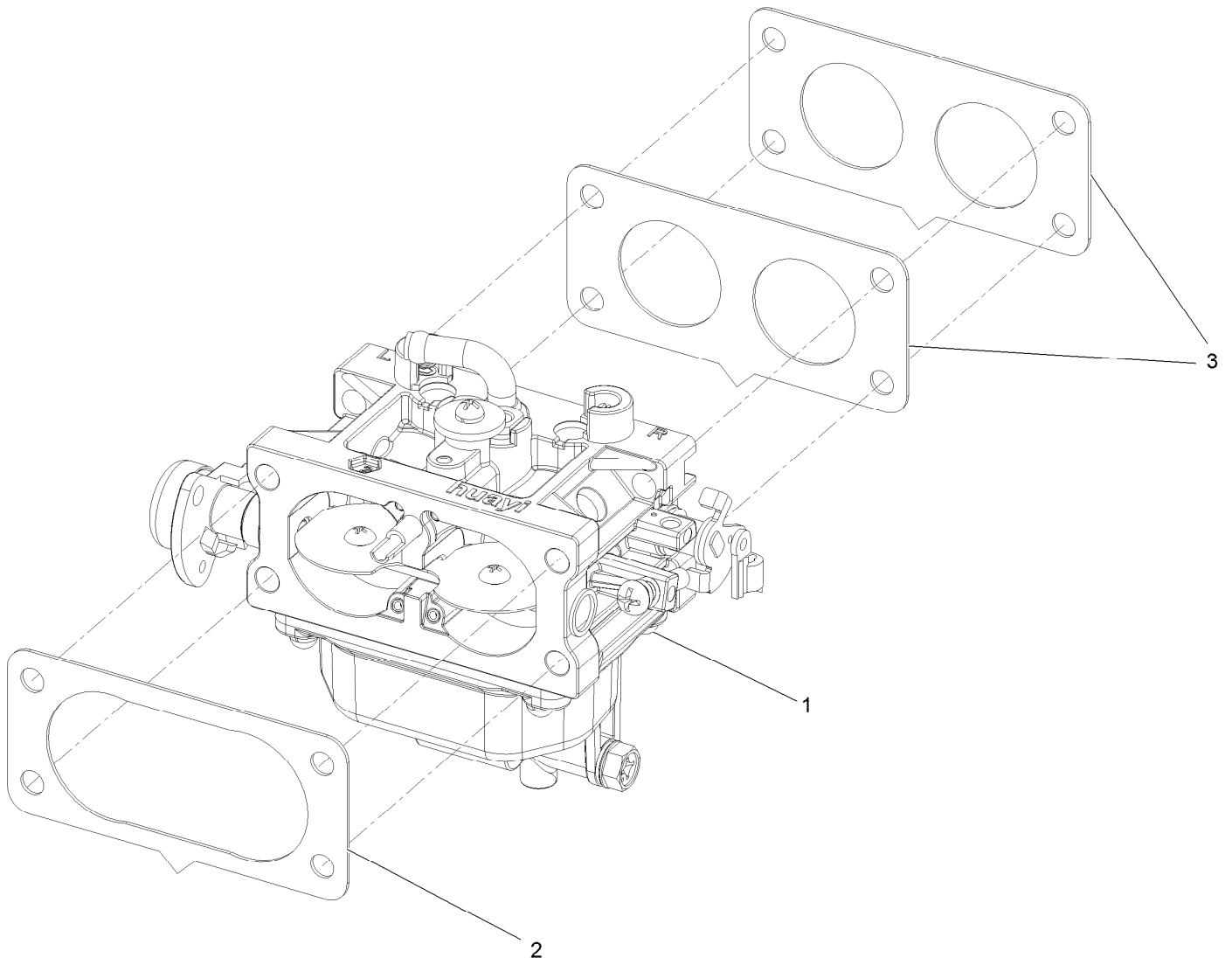

Carburetor Assembly (continued)

<i>Ref.</i>	<i>Part Number</i>	<i>Qty.</i>	<i>Description</i>
1		1	Carburetor ●
2	127-9251	1	Gasket-Carburetor
3	127-9246	2	Gasket-Carburetor

● Not serviced separately

Air Intake and Filtration Assembly

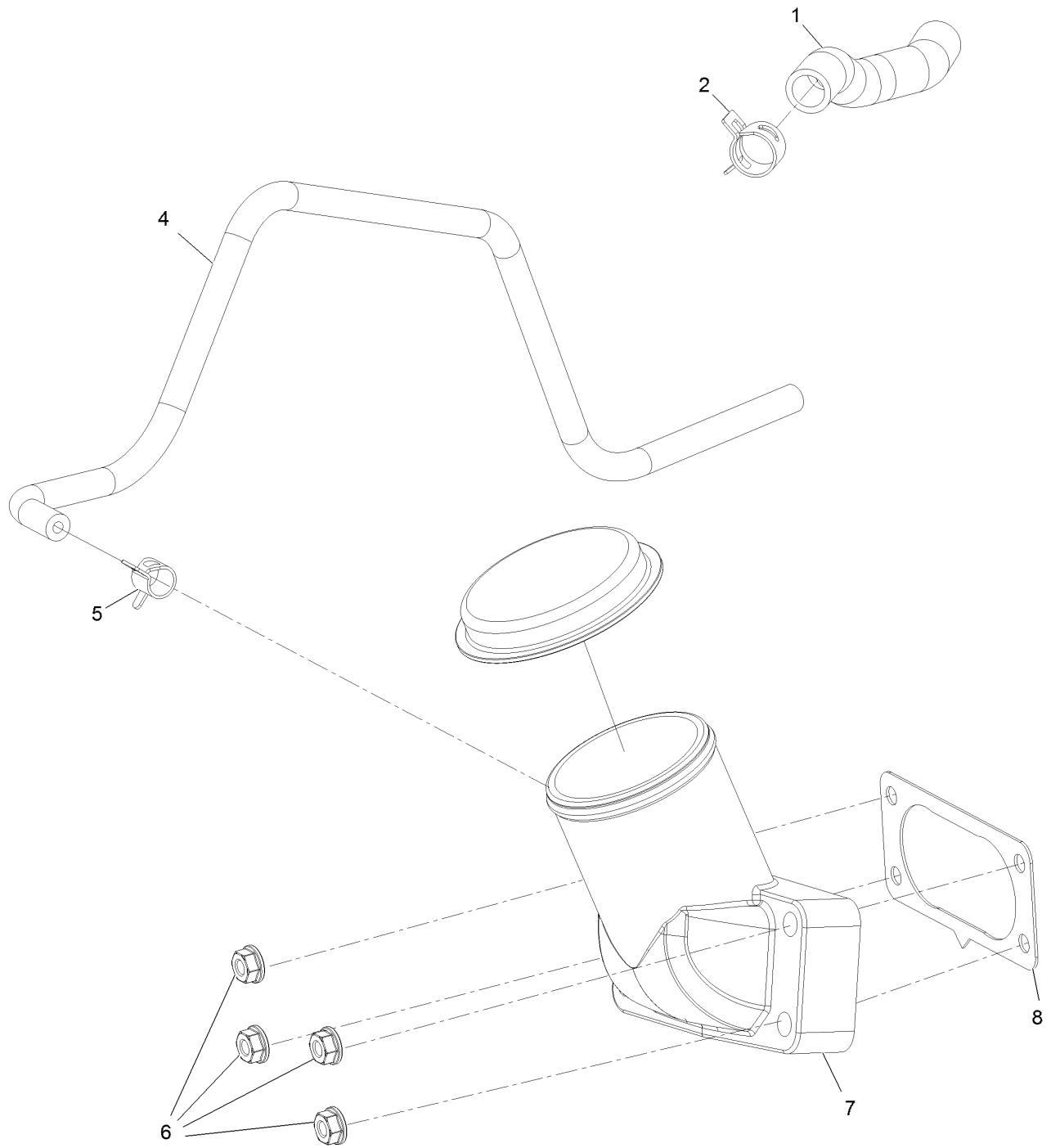

Air Intake and Filtration Assembly (continued)

<i>Ref.</i>	<i>Part Number</i>	<i>Qty.</i>	<i>Description</i>	<i>Ref.</i>	<i>Part Number</i>	<i>Qty.</i>	<i>Description</i>
1	127-9235	1	Tube-Breather	6	120-4236	4	Nut-Flange
2	127-9234	2	Clamp-Hose	7	136-9241	1	Manifold-Intake
4	127-9253	1	Hose-Fuel	8	127-9251	1	Gasket-Carburetor
5	127-9187	1	Clamp-Hose				

Ignition and Cooling Fan

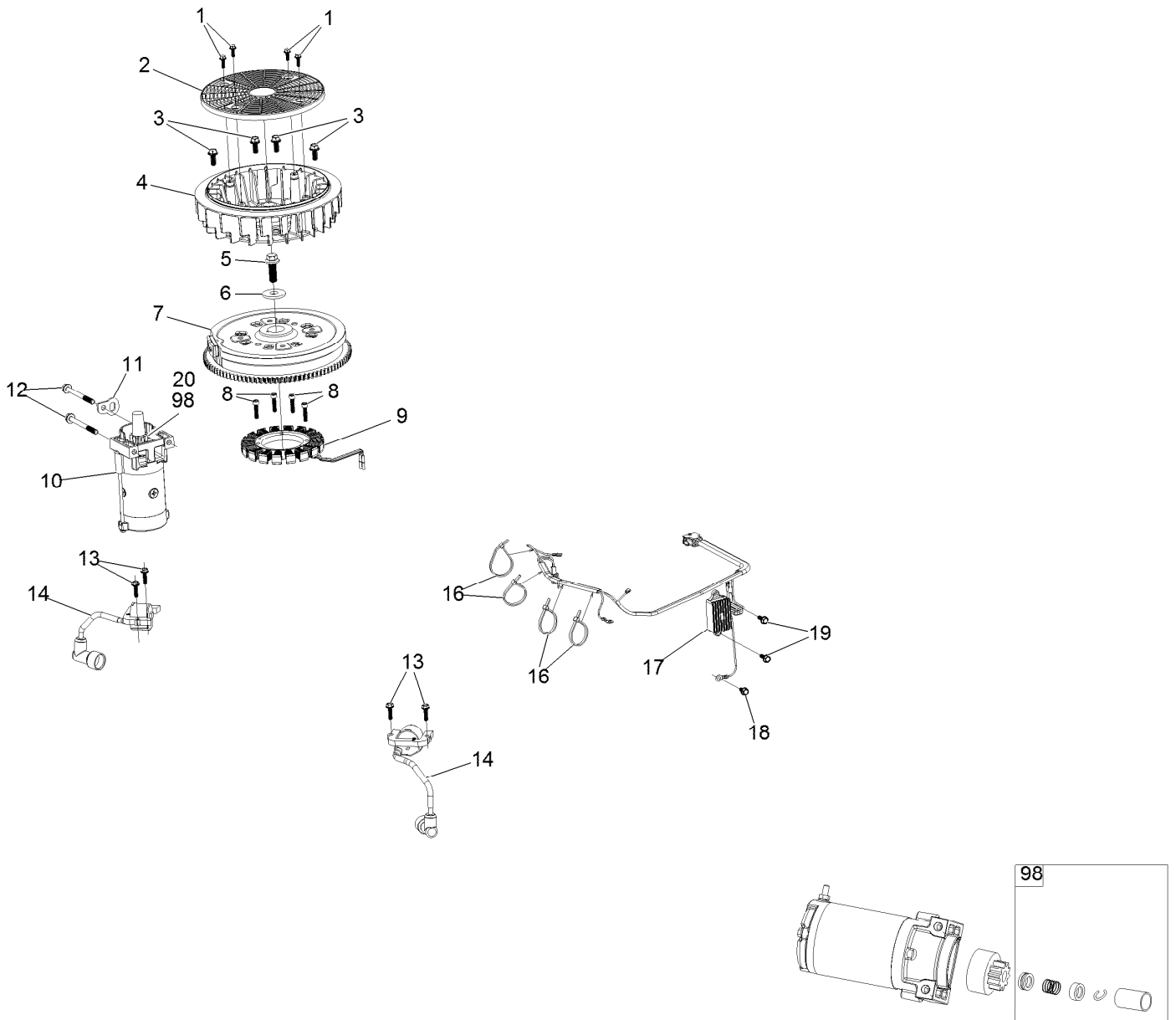

Ignition and Cooling Fan (continued)

<i>Ref.</i>	<i>Part Number</i>	<i>Qty.</i>	<i>Description</i>	<i>Ref.</i>	<i>Part Number</i>	<i>Qty.</i>	<i>Description</i>
1	127-9197	4	Screw-HWH	12	120-4231	2	Screw-HHF
2	127-9198	1	Screen-Rotating	13	121-0007	4	Bolt-Flange
3	127-9199	4	Screw-HWH	14	136-7883	2	Ignition Coil ASM
4	127-9200	1	Fan-Cooling	16	127-9220	4	Tie-Zip
5	127-9201	1	Screw-HWH	17	136-7879	1	Regulator-Voltage, W/Harness
6	127-9202	1	Washer-Flat	18	120-4216	1	Screw-HHF
7	127-9306	1	Flywheel	19	120-4232	2	Screw-HHF
8	127-9210	4	Screw-HSH	20	133-1562	1	Pinion-Starter
9	136-7876	1	Alternator	98	133-1566	1	Starter Repair Kit
10	136-7880	1	Motor-Starter				
11	127-9208	1	Bracket-Lift				

Crankcase and Crankshaft Assembly

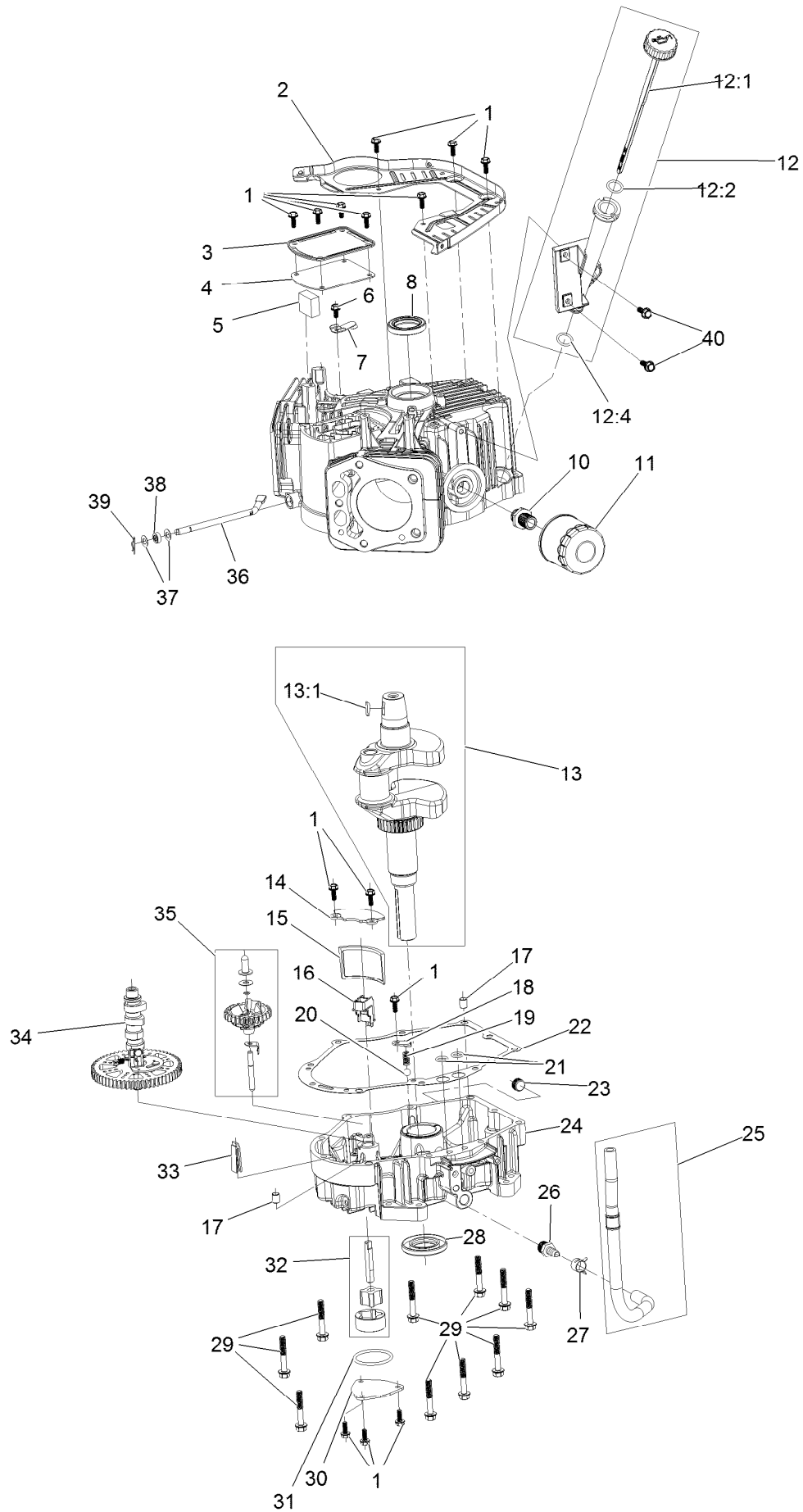

Crankcase and Crankshaft Assembly (continued)

<i>Ref.</i>	<i>Part Number</i>	<i>Qty.</i>	<i>Description</i>	<i>Ref.</i>	<i>Part Number</i>	<i>Qty.</i>	<i>Description</i>
1	120-4232	14	Screw-HHF	20	127-9266	1	Valve-Ball
2	127-9212	1	Baffle	21	120-4262	2	O-Ring
3	127-9213	1	Cover-Breather	22	127-9267	1	Gasket-Cover, Crankcase
4	127-9214	1	Gasket-Breather	23	133-9805	1	Plug-Drain
5	127-9215	1	Filter-Breather	24	127-9268	1	Cover-Crankcase
6	120-4216	1	Screw-HHF	25	127-9293	1	Oil Drain Hose ASM
7	127-9217	1	Valve-Breather	26	127-9275	1	Fitting-Hose
8	120-4267	1	Seal-Oil	27	127-9276	1	Clamp-Hose
10	136-7884	1	Adaptor-Filter, Oil	28	127-9271	1	Seal
11	136-7848	1	Filter-Oil	29	121-0473	10	Screw-HHF
12	127-9218	1	Oil Tube ASM	30	127-9274	1	Cover-Oil Pump
12:1	127-9283	1	Dipstick	31	127-9273	1	O-Ring
12:2	127-9284	1	O-Ring	32	127-9272	1	Oil Pump ASM
12:4	127-9286	1	O-Ring	33	120-4275	1	Deflector-Oil, Rubber
13	127-9255	1	Crankshaft	34	133-1568	1	Camshaft
13:1	120-4320	1	Key-Woodruff	35	136-7882	1	Governor ASM
14	127-9261	1	Cover-Screen, Oil	36	127-9238	1	Rod-Governor
15	127-9262	1	Screen-Oil	37	120-4258	2	Washer-Plain
16	127-9263	1	Retainer-Screen	38	120-4257	1	Seal-Oil
17	120-4274	2	Pin-Dowel	39	120-4256	1	Pin-Hair
18	127-9264	1	Plate-Retainer	40	120-4232	2	Screw-HHF
19	127-9265	1	Spring				

Governor Control Assembly

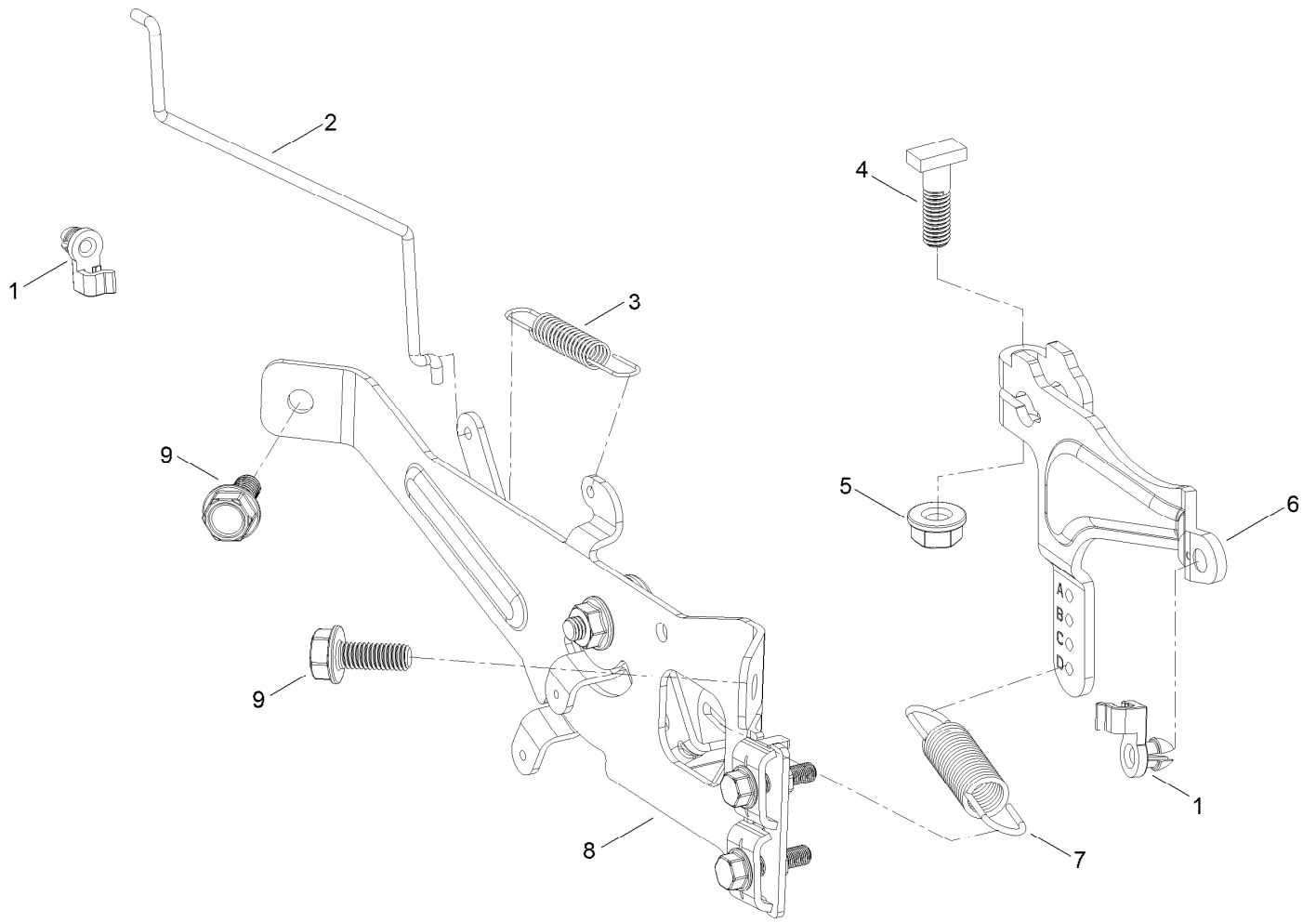

Governor Control Assembly (continued)

<i>Ref.</i>	<i>Part Number</i>	<i>Qty.</i>	<i>Description</i>	<i>Ref.</i>	<i>Part Number</i>	<i>Qty.</i>	<i>Description</i>
1	127-9250	2	Clip-Linkage	6	133-9961	1	Arm-Governor
2	127-9242	1	Linkage-Choke	7	133-9962	1	Spring-Governor
3	127-9241	1	Spring-Governor	8	133-1570	1	Control Plate ASM
4	120-4238	1	Bolt-Arm, Governor	9	120-4232	2	Screw-HHF
5	120-4236	1	Nut-Flange				

Piston and Cylinder Head Assembly

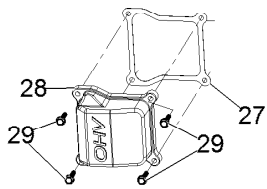
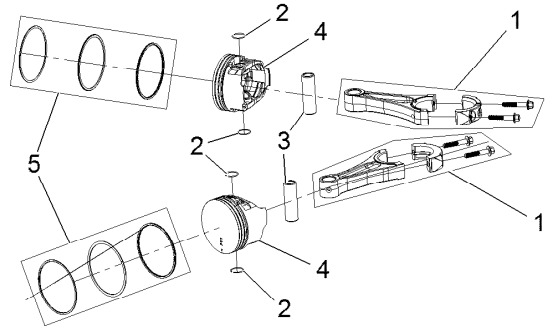
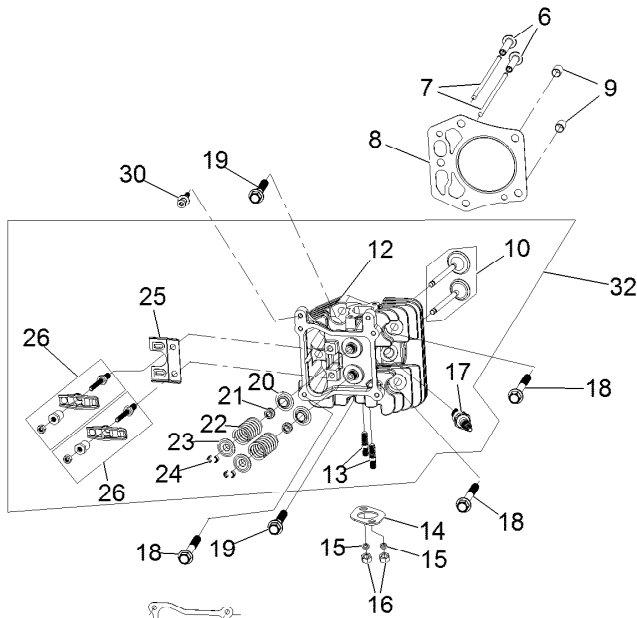
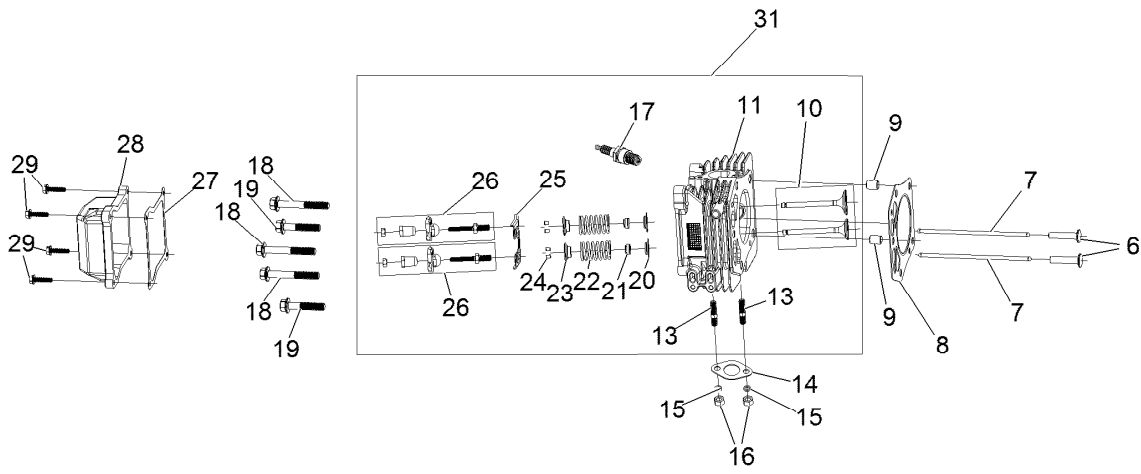

Piston and Cylinder Head Assembly (continued)

<i>Ref.</i>	<i>Part Number</i>	<i>Qty.</i>	<i>Description</i>	<i>Ref.</i>	<i>Part Number</i>	<i>Qty.</i>	<i>Description</i>
1	127-9256	2	Connecting Rod ASM	17	81-3250	2	Spark Plug
2	127-9258	4	Clip-Pin, Piston	18	127-9231	6	Screw-HWH
3	127-9257	2	Pin-Piston	19	127-9232	4	Screw-HWH
4	127-9259	2	Piston	20	120-4303	4	Seat-Spring, Valve
5	127-9260	2	Piston Ring Set	21	120-4304	4	Seal-Stem, Valve
6	127-9224	4	Lifter-Valve	22	120-4305	4	Spring-Valve
7	127-9225	4	Rod-Push	23	120-4306	4	Retainer-Spring, Valve
8	127-9226	2	Gasket-Head, Cylinder	24	120-4307	8	Keeper-Valve
9	127-9227	4	Pin-Dowel	25	127-9233	2	Plate-Guide, Push Rod
10	127-9228	2	Valve Set	26	136-7881	4	Rocker Arm ASM
11	127-9229	1	Head-Cylinder	27	127-9295	2	Gasket-Valve Cover
12	127-9254	1	Head-Cylinder	28	127-9050	2	Cover-Valve
13	121-0464	4	Stud-Exhaust	29	120-4225	8	Screw-HHF
14	120-4317	2	Gasket-Exhaust	30	120-4214	1	Screw-Shoulder, HH
15	127-9279	4	Washer-Lock, Split	31	136-7891	1	Complete Right Head ASM
16	121-0199	4	Nut-Hex M8	32	136-7892	1	Complete Left Head ASM

Blower Housing Assembly

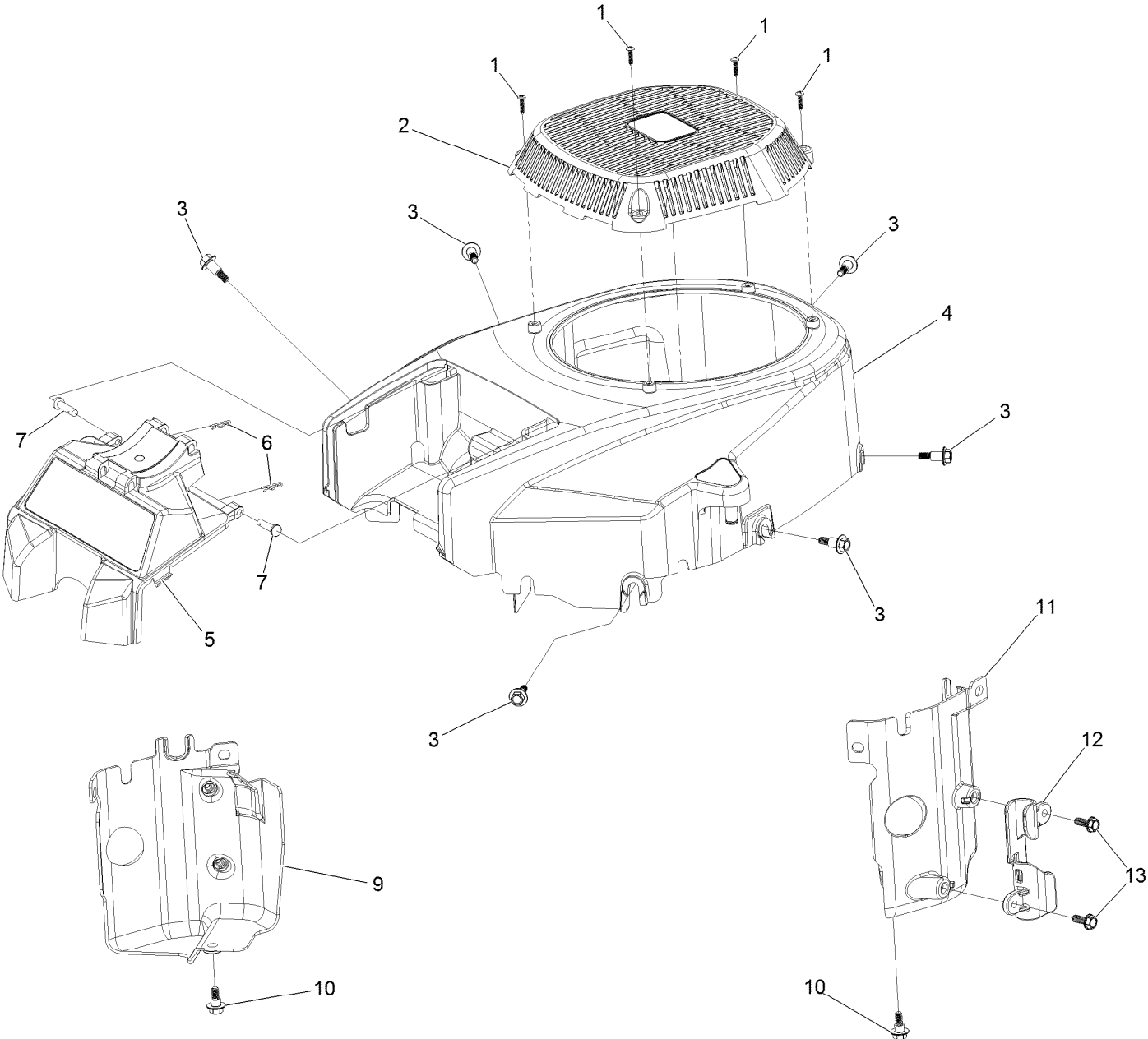

Blower Housing Assembly (continued)

<i>Ref.</i>	<i>Part Number</i>	<i>Qty.</i>	<i>Description</i>	<i>Ref.</i>	<i>Part Number</i>	<i>Qty.</i>	<i>Description</i>
1	133-1571	4	Screw-PPH, Plastic	7	127-9282	2	Pin
2	127-9045	1	Cover-Fan	9	136-7877	1	Baffle-Air, Left
3	127-9196	6	Screw-Shoulder, HWH	10	120-4210	2	Screw-Shoulder, HHF
4	133-1572	1	Shroud-Engine	11	136-7878	1	Baffle-Air, Right
5	136-5585	1	Support-Filter	12	127-9287	1	Cleat-Hose
6	127-9280	2	Pin-Hair	13	120-4232	2	Screw-HHF

Gasket and Seal Kit

1

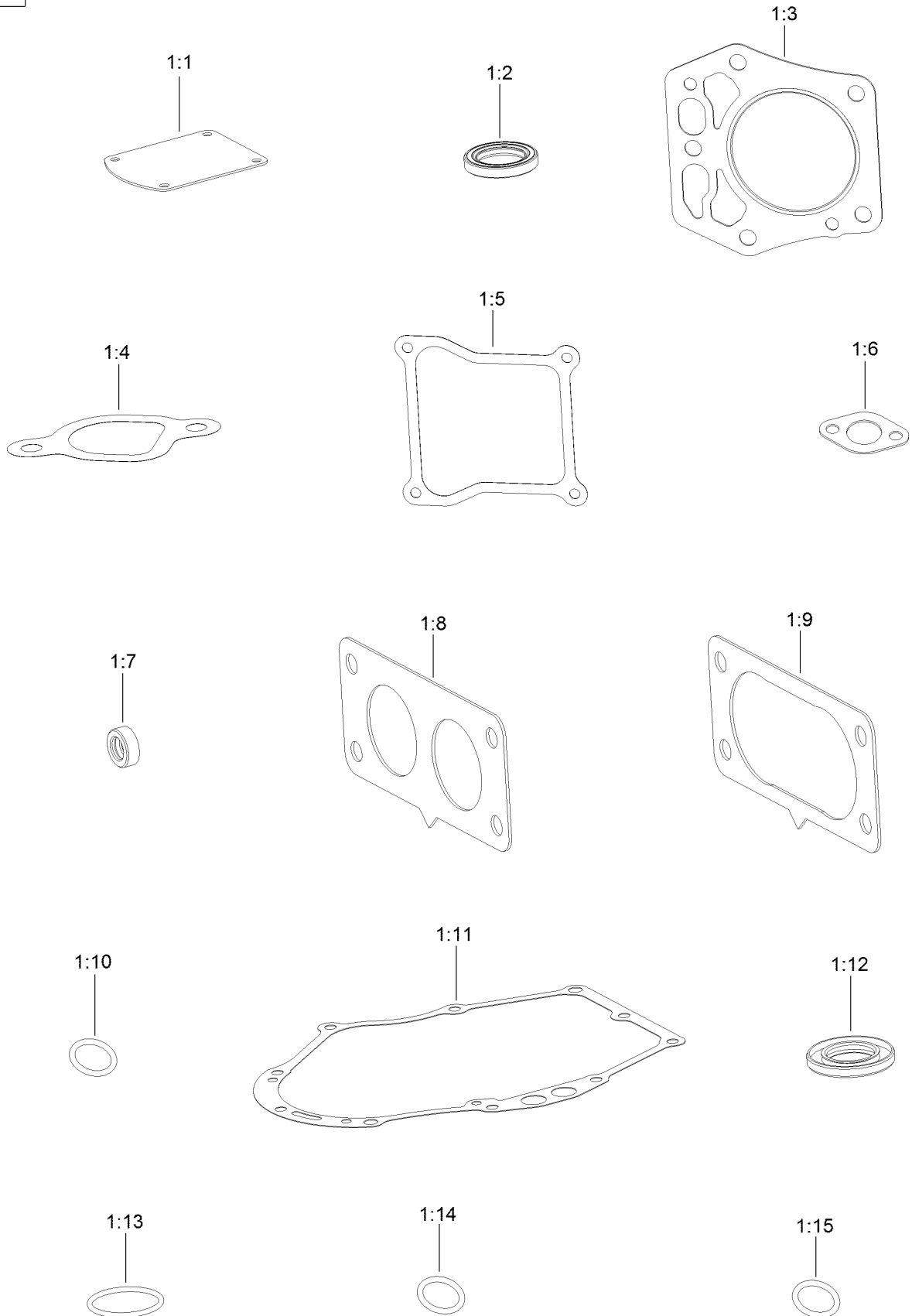

Gasket and Seal Kit (continued)

<i>Ref.</i>	<i>Part Number</i>	<i>Qty.</i>	<i>Description</i>	<i>Ref.</i>	<i>Part Number</i>	<i>Qty.</i>	<i>Description</i>
1	127-9296	1	Gasket And Seal Kit	1:8	127-9246	2	Gasket-Carburetor
1:1	127-9214	1	Gasket-Breather	1:9	127-9251	1	Gasket-Carburetor
1:2	120-4267	1	Seal-Oil	1:10	120-4262	2	O-Ring
1:3	127-9226	2	Gasket-Head, Cylinder	1:11	127-9267	1	Gasket-Cover, Crankcase
1:4	127-9230	2	Gasket-Intake	1:12	127-9271	1	Seal
1:5	127-9295	2	Gasket-Valve Cover	1:13	127-9273	1	O-Ring
1:6	120-4317	2	Gasket-Exhaust	1:14	127-9284	1	O-Ring
1:7	120-4257	1	Seal-Oil	1:15	127-9286	1	O-Ring

Suspension Assembly

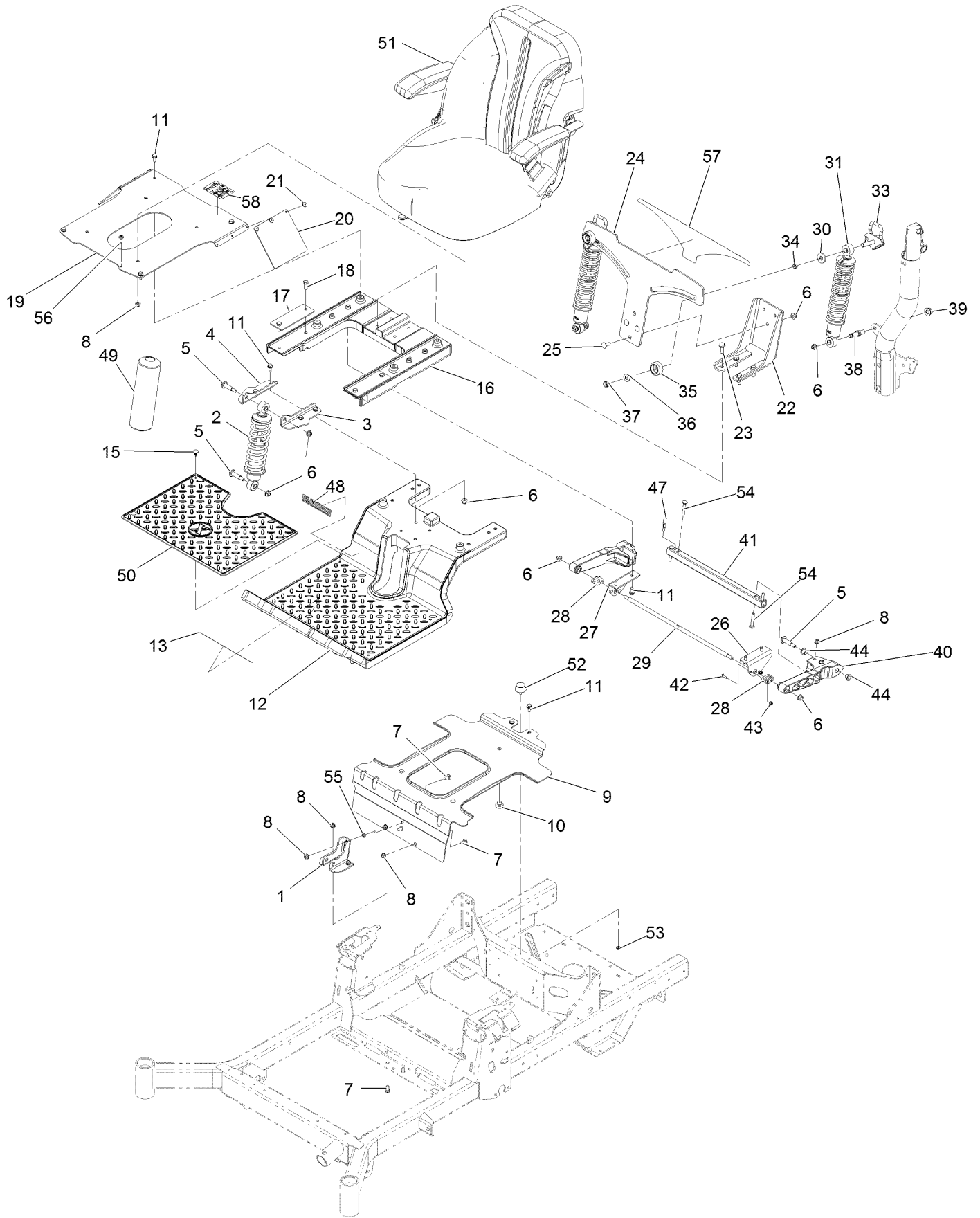

Suspension Assembly (continued)

<i>Ref.</i>	<i>Part Number</i>	<i>Qty.</i>	<i>Description</i>	<i>Ref.</i>	<i>Part Number</i>	<i>Qty.</i>	<i>Description</i>
1	133-1864-03	1	Bracket-Shock, Front Lower	27	136-1742-03	1	Bracket-Arm, Trailing (RH)
2	136-8971	1	Shock/Spring	28	127-0146	2	Bearing-Flange
3	133-9318-03	1	Bracket-Shock Mount, Upper (LH)	29	136-1739	1	Rod-Pivot
4	133-9319-03	1	Bracket-Shock Mount, Upper (RH)	30	131-4699	2	Washer-Plastic
5	136-9028	4	Bolt-Shoulder, HWH	31	133-5154	2	Shock/Spring ASM
6	104-8301	13	Nut-Nyloc 3/8-16 Flg	33	136-5634	2	Cam Lock ASM
7	3230-23	6	Bolt-Carriage 5/16-18 X 3/4 Short Neck	34	133-5109	2	Bearing-Sleeve
8	104-8300	14	Nut-Nyloc 5/16-18 Flg	35	136-5636	2	Knob-Lock, Cam
9	136-8963-03	1	Bracket-Tank	36	3-6803	2	Washer-Adjusting
10	135-0505	3	Bumper-Seat	37	3296-45	2	Nut-Nyloc 1/2-13 Thin
11	32144-70	14	Screw-HWH 5/16-18 X 3/4 Tf	38	133-4401	2	Bolt-Shoulder
12	133-7083-01	1	Subframe-Front	39	99-5107	2	Nut-Lock 1/2-13
13	132-0871	1	Decal-Danger	40	136-8979	2	Trailing Arm
15	117-2382	4	Plug-Plastic	41	137-9754-03	1	Tube-Arm, Trailing
16	137-7031-01	1	Subframe-Rear	42	3229-20	4	Screw-CARR
17	133-7089-03	2	Plate-Backer	43	120-4578	4	Nut-HF
18	323-6	4	Screw-HH 3/8-16 X 1	44	125-5239	4	Bushing-Flange
19	136-8962-03	1	Plate-Seat	47	105-1853	1	Clamp-Hose
20	136-8967	2	Flap-Rubber	48	136-8966	1	Decal-Radius Logo
21	132-5064	6	Rivet-Pop	49	136-8972	1	Cover-Shock
22	136-8955-03	1	Bracket-Mount, Lower	50	136-8957	1	Floor Mat
23	32144-109	4	Screw-HWH 3/8-16 X 1 1/4 Taptite	51	135-3442	1	ASM-Seat Exmark
24	136-1744-03	1	Plate-Mounting, Adj Shock	52	131-8834	1	Bumper
25	3231-22	3	Bolt-Carriage 3/8-16 X 1	53	104-7201	1	Nut-Nyloc 1/4-20 Flg
26	136-1741-03	1	Bracket-Arm, Trailing (LH)	54	3230-6	4	Bolt-Carriage 3/16-18 X 2
				55	117-2749	2	Nut-Push
				56	135-2015	1	Screw-Shoulder
				57	136-8952	1	Decal-Adjustment, Ride
				58	136-9024	1	Decal-Aid, Service

Seat Assembly

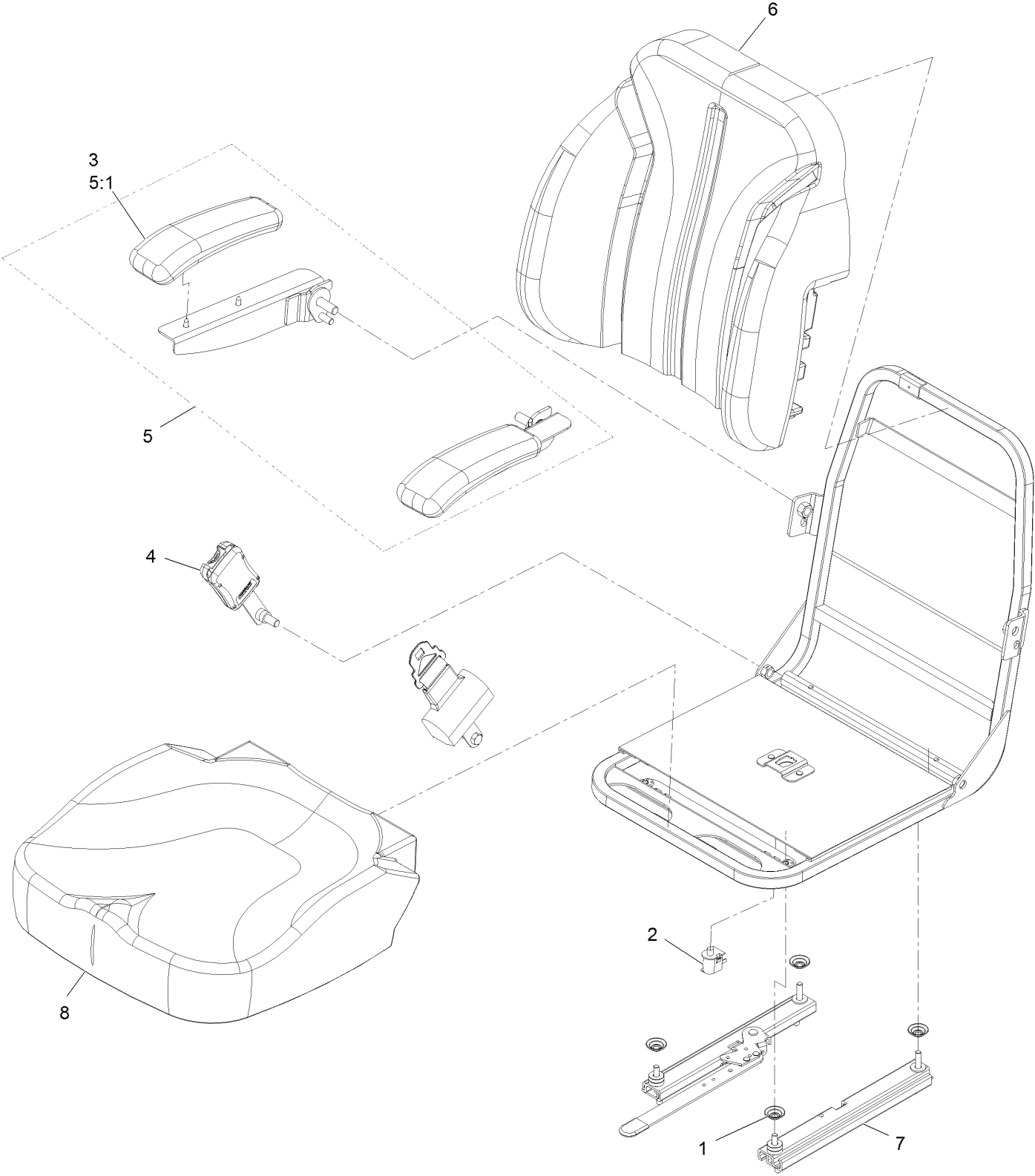

Seat Assembly (continued)

<i>Ref.</i>	<i>Part Number</i>	<i>Qty.</i>	<i>Description</i>	<i>Ref.</i>	<i>Part Number</i>	<i>Qty.</i>	<i>Description</i>
1	136-9002	4	Spacer-Mounting	5:1	110-4163	2	Cushion-Rest, Arm
2	82-2190	1	Switch	6	126-8552	1	Cover-Seat Back Svc
3	110-4163	2	Cushion-Rest, Arm	7	126-2177	1	Track-Seat
4	126-9091	1	Seat Belt Kit	8	136-9000	1	Cover-Seat Bottom Svc
5	126-2058	1	Armrest Kit				

Hydraulic Drive Assembly

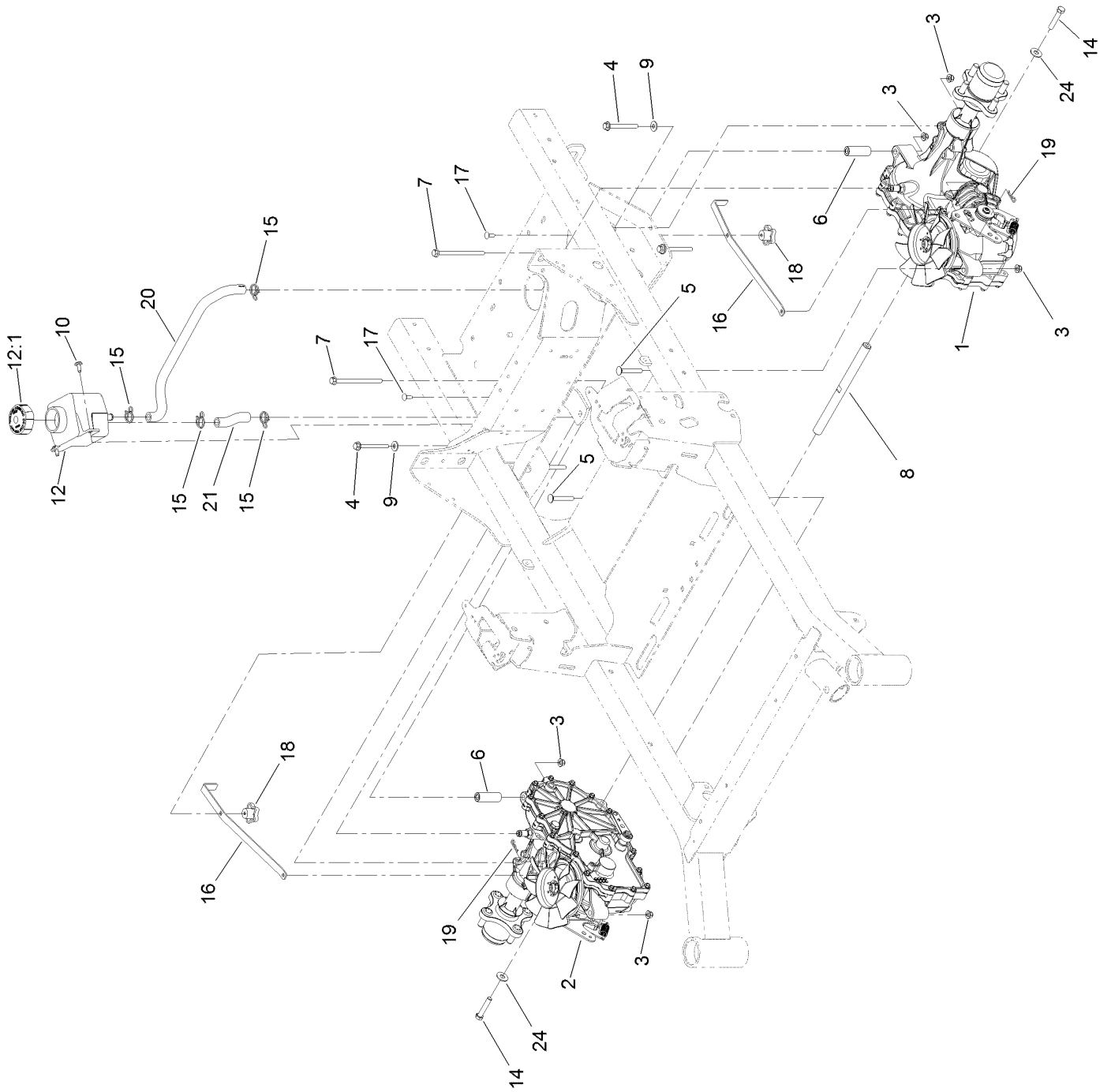

Hydraulic Drive Assembly (continued)

<i>Ref.</i>	<i>Part Number</i>	<i>Qty.</i>	<i>Description</i>	<i>Ref.</i>	<i>Part Number</i>	<i>Qty.</i>	<i>Description</i>
1	135-0140	1	LH Transaxle ASM	12:1	109-3320	1	Cap-Reservoir, HYD
2	135-0139	1	RH Transaxle ASM	14	94-7972	2	Screw-HH W/Loctite ●
3	104-8300	8	Nut-HF, NI	15	126-0327	4	Clamp-Hose
4	126-4687	4	Screw-HHF	16	109-5395	2	Arm-Bypass, Hydro
5	3230-7	2	Bolt-CARR	17	3229-1	2	Bolt-CARR
6	116-5809	2	Spacer-Hydro	18	108-6402	2	Knob-Handle
7	126-5896	2	Screw HHF	19	1-806003	2	Pin-Cotter
8	116-6833	1	Shaft-Spacer	20	133-1325	1	Hose-Hydraulic
9	1-303334	4	Washer-Spring	21	133-1320	1	Hose-Hydraulic
10	126-6266	2	Screw-Torx	24	3256-4	2	Washer-Flat
12	109-2250	1	Tank-HYD				

● Use Pro-Lock, Nut Type (P/N 1-840022, .5ml tube) on threads.

LH Transaxle Assembly

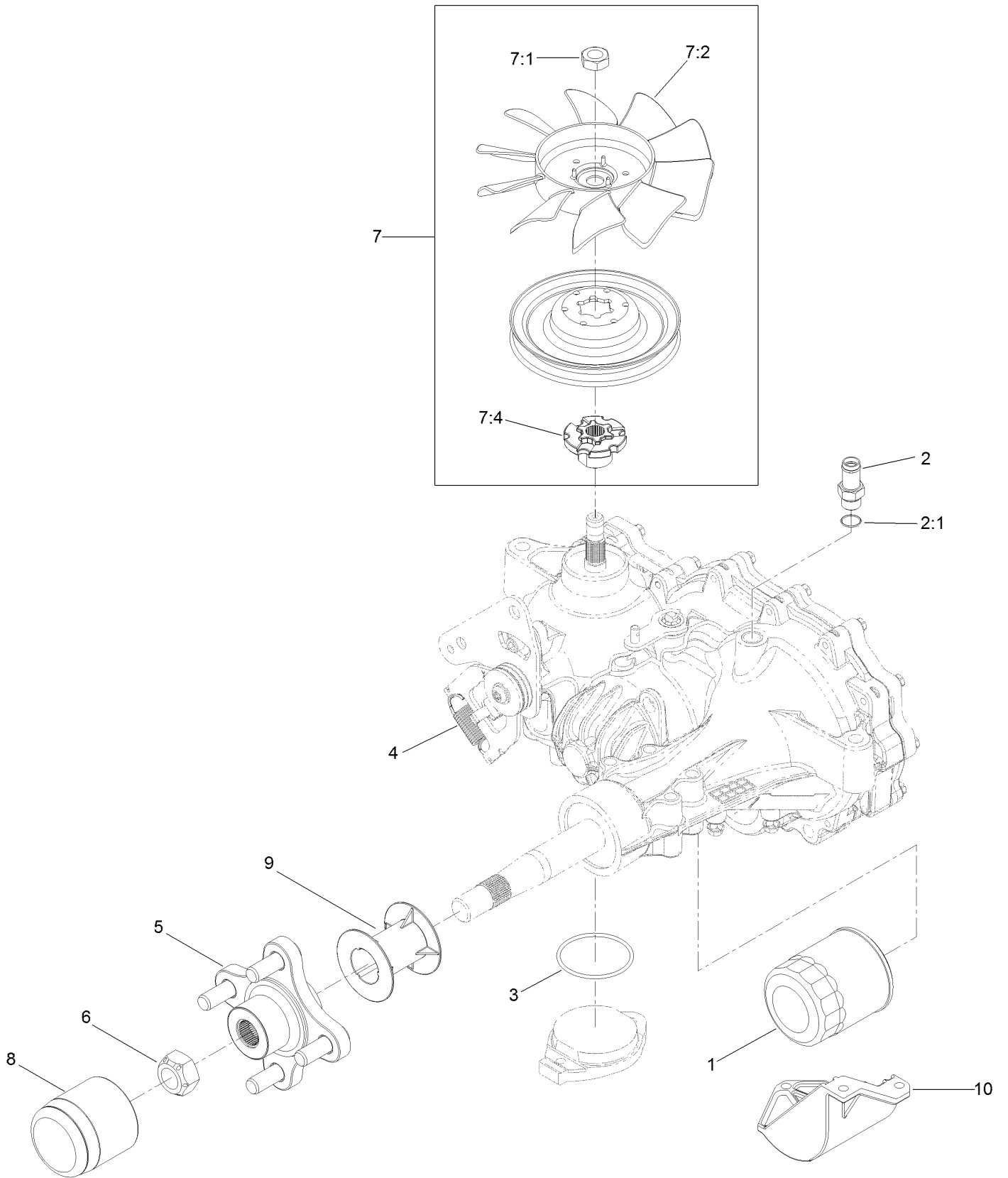

LH Transaxle Assembly (continued)

<i>Ref.</i>	<i>Part Number</i>	<i>Qty.</i>	<i>Description</i>	<i>Ref.</i>	<i>Part Number</i>	<i>Qty.</i>	<i>Description</i>
1	109-3321	1	Filter-Hydraulic	7:1	116-9714	1	Nut-HJ
2	109-3278	1	Adapter-Straight	7:2	126-0226	1	Fan
2:1	237-42	1	O-Ring	7:4	116-9705	1	Hub-Pulley
3	109-3540	1	O-Ring-Charge Seal Cover	8	116-6214	1	Cap-Axle, Long
4	109-5592	1	Spring	9	116-6213	1	Tube-Axle
5	116-3872	1	Hub-Offset	10	120-7979	1	Guard-Filter, LH
6	109-3536	1	Nut-Hub	99	109-3537	1	Seal Kit ●
7	125-0059	1	Fan And Pulley Kit	99	135-3604	1	Brake Shaft Seal Kit

● Not illustrated

RH Transaxle Assembly

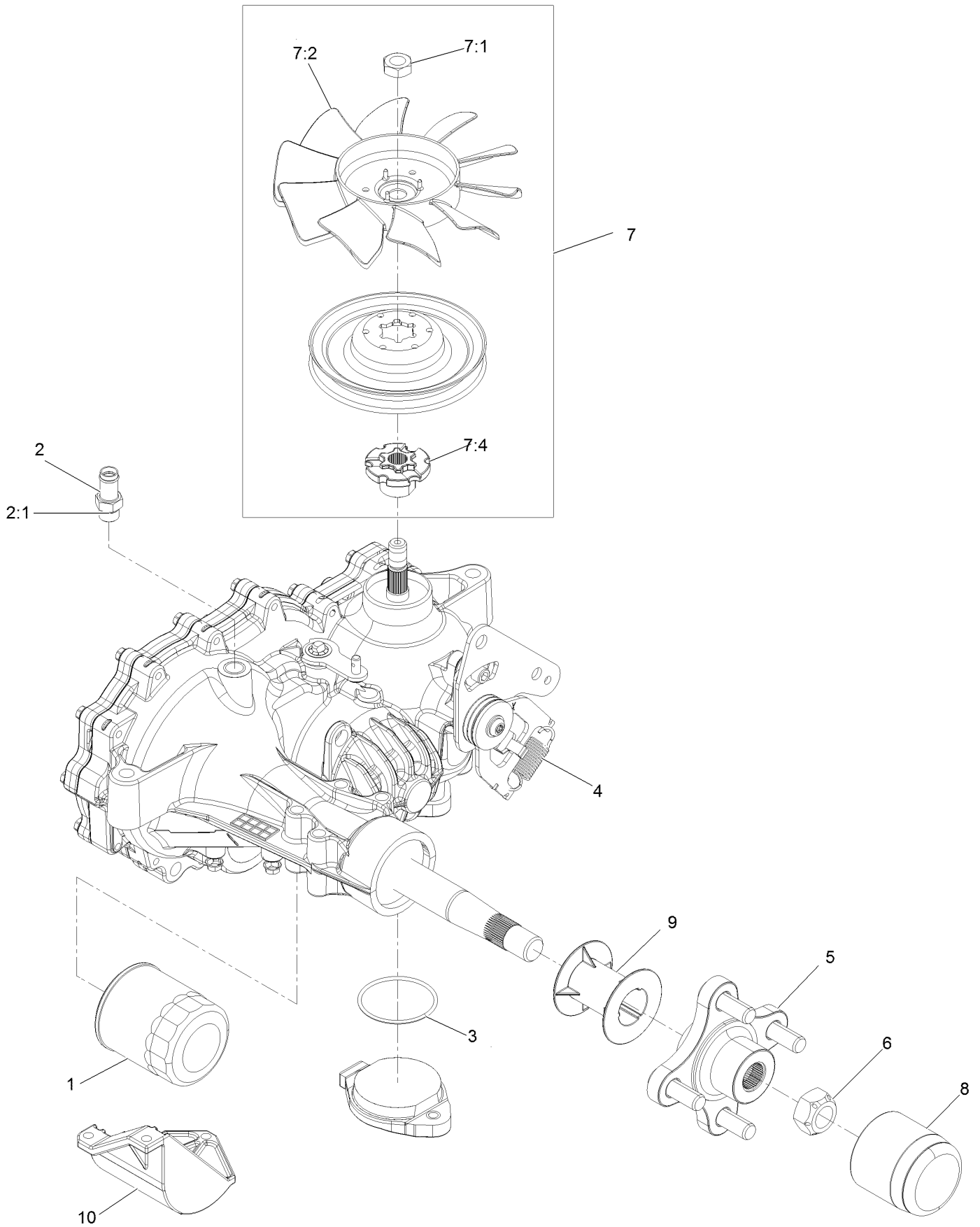

RH Transaxle Assembly (continued)

<i>Ref.</i>	<i>Part Number</i>	<i>Qty.</i>	<i>Description</i>	<i>Ref.</i>	<i>Part Number</i>	<i>Qty.</i>	<i>Description</i>
1	109-3321	1	Element-Oil Filter, HYD	7:1	116-9714	1	Nut-HJ
2	109-3278	1	Adapter-Straight	7:2	126-0226	1	Fan
2:1	237-42	1	O-Ring	7:4	116-9705	1	Hub-Pulley
3	109-3540	1	O Ring-Seal	8	116-6214	1	Cap-Axle, Long
4	109-5592	1	Spring-Extension	9	116-6213	1	Tube-Axle
5	116-3872	1	Hub-Offset	10	120-7981	1	Guard-Filter, RH
6	109-3536	1	Nut-Hub	99	109-3537	1	Seal Kit ●
7	125-0059	1	Fan And Pulley Kit	99	135-3604	1	Brake Shaft Seal Kit

● Not illustrated

Electrical Assembly

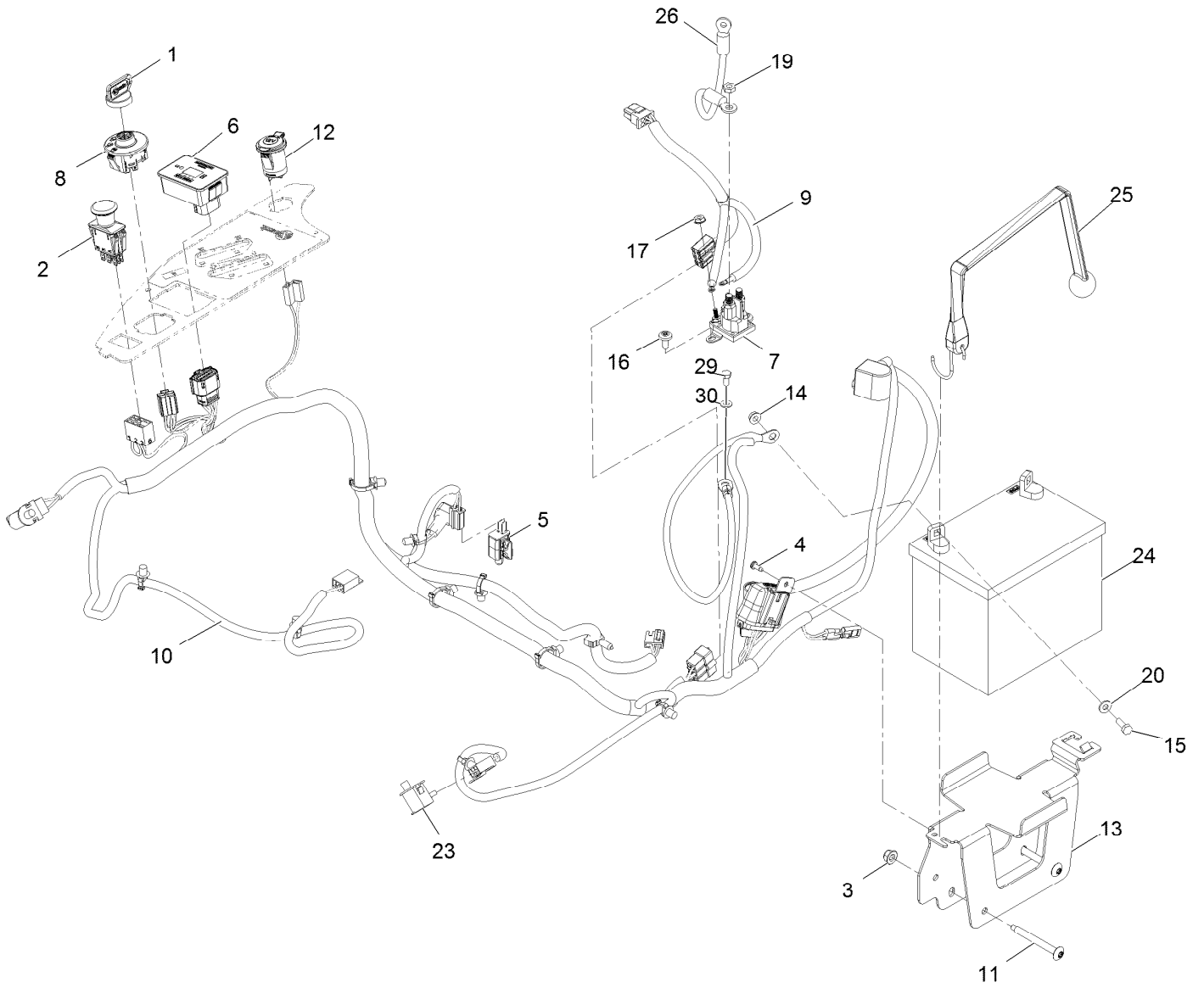

Electrical Assembly (continued)

<i>Ref.</i>	<i>Part Number</i>	<i>Qty.</i>	<i>Description</i>	<i>Ref.</i>	<i>Part Number</i>	<i>Qty.</i>	<i>Description</i>
1	1-603511	1	Key-Ignition	13	126-6725-03	1	Tray-Battery
1	103-2106	1	Key-Exmark Logo	14	32128-33	2	Nut-Whizlock 1/4-20
2	103-5221	1	Switch-PTO	15	321-4	2	Screw-HH 1/4-20 X 3/4
3	104-8300	2	Nut-Nyloc 5/16-18 Flg	16	126-6266	2	Screw-1/4-20 X .65 Torx Plus
4	105-6849	1	Screw-Tph #10-24 X 1/2 Tf	17	32149-8	2	Nut-Keps 10-32 Unf Yz
5	110-6765	1	Switch	19	3220-2	1	Nut-Jam 5/16-24
6	116-5609	1	Module ASM	20	3256-22	2	Washer-1/4 SAE
7	117-1197	1	Solenoid	23	82-2190	2	Switch
8	137-4100	1	Switch-Ignition	24		1	Battery (300 CCA, Wet) ●■
9	126-5036	1	Adapter-Harness, Wire	25	126-7627	1	Strap-Bungee
10	126-5803	1	Harness-Wire ▲	26	100-3540	1	Cable-Battery, Positive
11	126-6267	2	Screw-Truss HD 5/16-18 X 2 3/4 Torx Plus	29	135-2868	1	Screw-HH
12	126-6499	1	Port-Power, 12V	30	3256-23	1	Washer-5/16 SAE

● Obtain locally.

■ Not serviced separately

▲ Use dielectric grease on all unsealed connectors and terminals only. Do not apply in sealed connectors.

Harness Assembly No. 126-5803

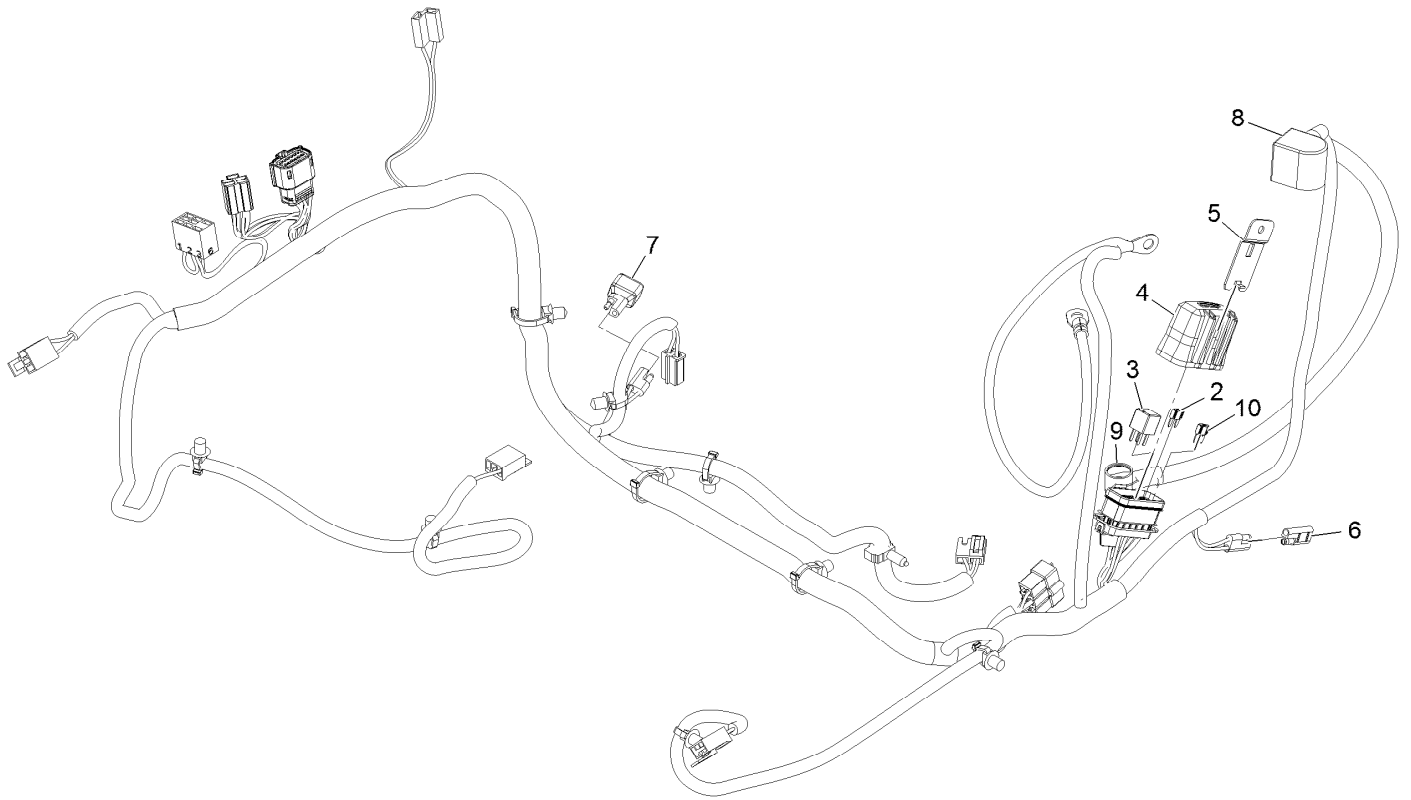

Harness Assembly No. 126-5803 (continued)

<i>Ref.</i>	<i>Part Number</i>	<i>Qty.</i>	<i>Description</i>
2	121-8868	1	Fuse-Mini Blade, 20 Amp
3	126-3991	1	Relay-Micro
4	32180-176	1	Cover-Block, Fuse
5	32180-177	1	Clip-Mounting
6	116-0053	1	Cap-Plug

<i>Ref.</i>	<i>Part Number</i>	<i>Qty.</i>	<i>Description</i>
7	103-3895	1	Diode
8	126-8876	1	Insulator-Battery
9	1-543393	1	Insulator-Solenoid
10	121-8867	1	Fuse-Mini Blade, 15 Amp

Notes:

Notes:

Notes:



MAXIMIZE THE PERFORMANCE OF YOUR EXMARK MACHINE.



EXMARK® PREMIUM ENGINE OIL

Exmark now offers a family of engine oil viscosities to perform well in any environment. Each viscosity has the same synthetic formulation to give you what you need in punishing conditions. We designed each grade to the highest quality, making it ideal even for diesel applications. Coupled with Exmark Premium Fuel Treatment, we have the performance products to make your machine hum.

EXMARK PREMIUM ENGINE OIL SAE 30/10W-30

- Meets zero shear requirements of a straight grade SAE 30 as well as the cold temp properties of a 10W-30.
- Most versatile oil in the industry.
- Superior corrosion protection over conventional oil - even in corrosive, humid environments.

EXMARK PREMIUM ENGINE OIL SAE 20W-50

- Perfect for your big block engine, or any application in severe service.
- Same full synthetic formulation as all other Exmark Premium viscosities.
- Also effective for use in severe service small block engines.

EXMARK PREMIUM ENGINE OIL SAE 10W-50

- Full synthetic formulation gives you peak performance. Don't settle for less.
- Wide span multi-grade combines easy starting in cold weather with maximum protection in high temperature operation.
- Reduce friction & wear over standard mineral formulations.

EXMARK PREMIUM ENGINE OIL SAE 0W-40

- The perfect choice for when the weather turns cold or unpredictable, and your Exmark UTV has to perform.
- Commercial quality for severe service.
- Advanced additive package helps prevent corrosion from long-term storage.

EXMARK PREMIUM ENGINE OIL UTV FORMULATION

- 4-cycle high-temp formulation.
- Heavier viscosity, full synthetic, perfect for your UTV.

EXMARK PREMIUM UTV EXTREME CONDITIONS GEAR OIL

- SAE 80W-90, designed to keep your UTV performing at its peak.
- Shear stable, hypoid gear lube.
- Includes a premium additive system to combat wear, oxidation, rust & corrosion.

Available from your local Exmark dealer. Find your closest dealer at exmark.com

EXMARK ACCESSORIES AND OPTIONS*

MID-MOUNT RIDING ACCESSORIES AND OPTIONS

CUSTOM RIDE SEAT SUSPENSION SYSTEM	OPERATOR CONTROLLED DISCHARGE
FULL SUSPENSION SEAT	SUN SHADE
DECK LIFT ASSIST KIT	TRASH CONTAINER
HITCH KIT	TURF STRIPER
LIGHT KIT	ULTRA VAC COLLECTION SYSTEM
12V POWER PORT	ULTRA VAC QUICK DISPOSAL SYSTEM
MICRO-MULCH SYSTEM	

OUT-FRONT RIDING ACCESSORIES AND OPTIONS

CUSTOM RIDE SEAT SUSPENSION SYSTEM	SNOW BLADE
DUAL-TAIL WHEEL	SNOWBLOWER
FLOOR PAN EXTENDER	SUN SHADE
HITCH KIT	TRASH CONTAINER
LIGHT KIT	ULTRA VAC COLLECTION SYSTEM
MICRO-MULCH SYSTEM	ULTRA VAC QUICK DISPOSAL SYSTEM
ROLL OVER PROTECTION SYSTEM (ROPS)	WEATHER CAB

WALK-BEHIND ACCESSORIES AND OPTIONS

GRASS CATCHER	TURF STRIPER
MICRO-MULCH SYSTEM	STANDON

*Some accessories and options not available for some models.

Place Model No. and Serial No.
Label Here (Included in the Literature
Pack) or Fill in Below

Model No. _____

Serial No. _____

Date Purchased _____

Engine Model No. and Spec. No. _____

Engine Serial No. (E/No) _____

© 2018 Exmark Mfg. Co., Inc.
2101 Ashland Ave
Beatrice, NE 68310
All Rights Reserved

Part No. 4503-537 Rev. A
(402) 223-6375
Fax (402) 223-5489
Printed in the USA.

