

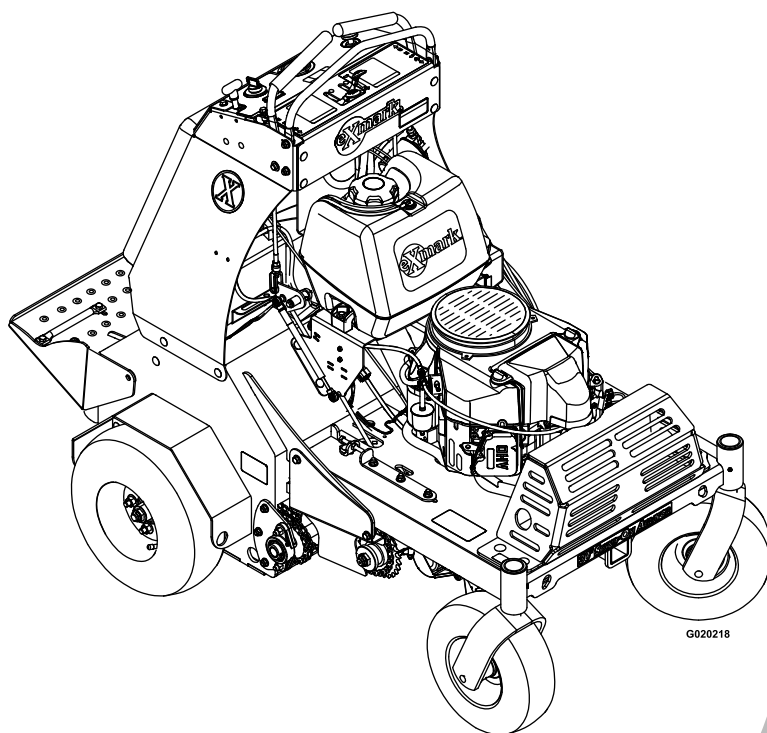

AERATOR 30

Model No. ARX541CKA30000—Serial No. 402082300 and Up

Picture below may not reflect actual product.



Parts Manual

Part No. 4503-523 Rev. A

Ordering Replacement Parts

To order replacement parts, please supply the part number, the quantity, and the description of each part desired.

Understanding Reference Numbers

Each identified part in an illustration has a reference number. The reference number for a part also appears in the parts list, along with other information about the part.

This catalog uses two special reference number formats, one to indicate parts in a service assembly and another to indicate the quantity of a given part in an illustration.

Service Assembly Reference Numbers

Parts in service assemblies have reference numbers in the form a:b. The a represents the reference number of the entire service assembly and the b represents a sequential number unique to each part within the service assembly.

For example, a wheel assembly might be identified by reference number 6, the tire by 6:1, the valve by 6:2, and the wheel by 6:3. When you order the assembly identified by reference number 6, you receive all parts identified by reference numbers 6:1, 6:2, and 6:3. However, you may also order any part individually. Reference numbers of this type appear in illustration and in parts lists.

Reference Numbers Indicating Quantity

In an illustration, if a reference number indicates more than one part, the reference number has the form nX y. The n represents the quantity of the part, the X is the multiplication symbol, and the y represents the reference number.

For example, in an illustration, the reference number 2X 37 means that two of the parts identified by reference number 37 are indicated.

Touch Up Paint

Exmark black touch up spray paint – gloss black.

Exmark red touch up paint (spray paint – P/N 1-850337 - .6 oz liquid bottle – P/N 103-9140).



If your Exmark dealer does not have the Exmark part in stock, Exmark will get the parts to the dealer the next business day or the part will be FREE Guaranteed!! (Some restrictions apply. See your participating Exmark Dealer for details.)

Contents

Main Frame Assembly	4
Main Frame Assembly	6
Main Frame Decal Assembly	8
Caster Wheel and Fork Assembly	10
Platform and Rocker Assembly	12
Tower Assembly	14
Motion Control Assembly	16
Engine Assembly	18
Fuel Assembly	20
Auxiliary Hydraulic Assembly	22
Manifold W/Check and Relief Valve Assembly No. 116-9549	24
Ground Drive Assembly	26
Idler Arm Assembly No. 116-9307	28
Axle and Bearing Assembly No. 116-9545	30
LH Transaxle Assembly No. 135-1051	32
RH Transaxle Assembly No. 135-1050	34
Tine Assembly	36
LH Tine Wheel Assembly No. 116-6739	38
RH Tine Wheel Assembly No. 116-6738	40
Electrical Assembly	42

Main Frame Assembly

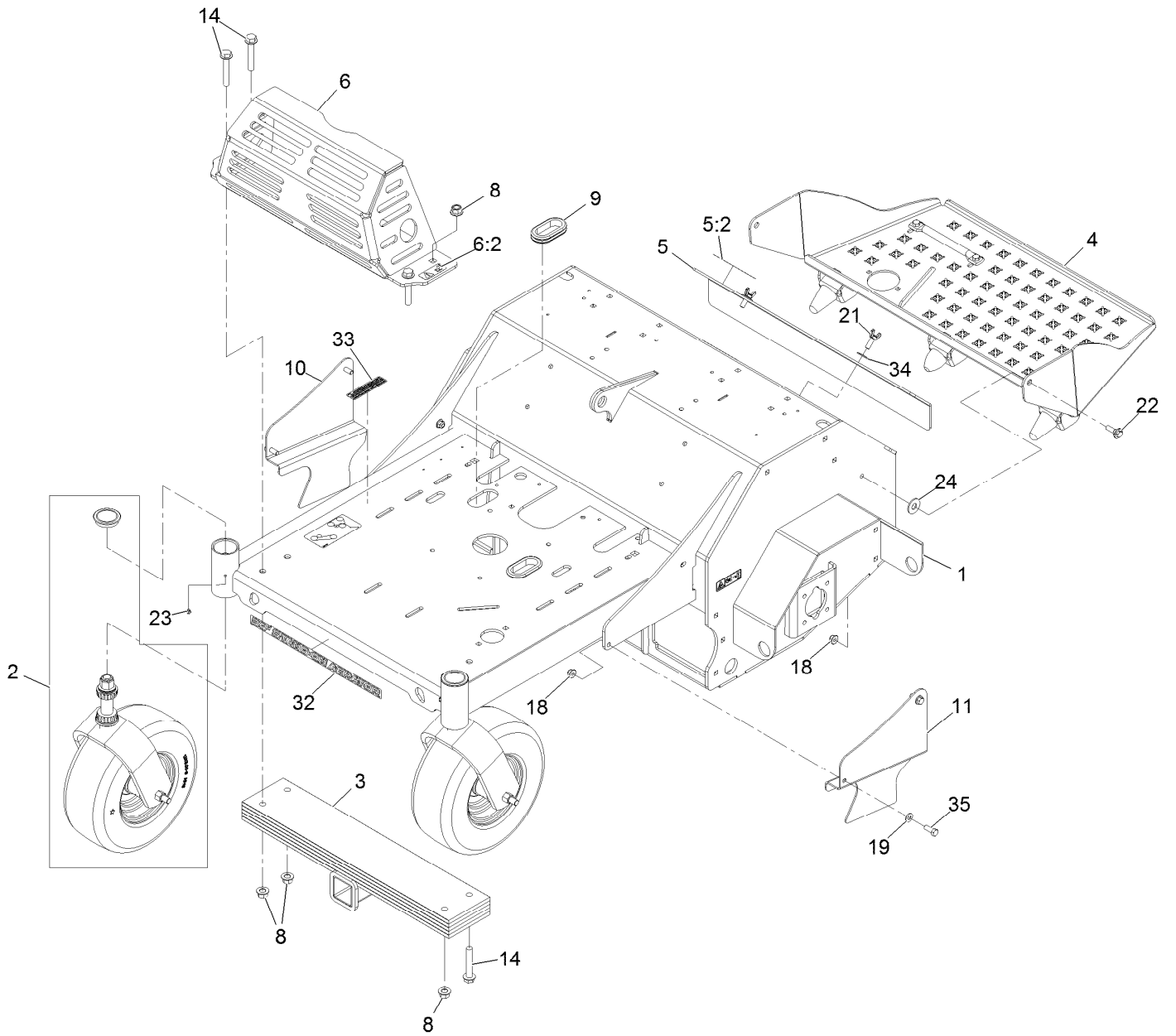

Main Frame Assembly (continued)

<i>Ref.</i>	<i>Part Number</i>	<i>Qty.</i>	<i>Description</i>	<i>Ref.</i>	<i>Part Number</i>	<i>Qty.</i>	<i>Description</i>
1	116-8138	1	Main Frame ASM	11	116-6611-01	1	Guard-Chain, LH
2		2	Front Caster ASM W/Fork ●	14	3234-40	4	Screw-HF
3	116-6536-01	1	Weight	18	104-8301	6	Nut-Nyloc 3/8-16 Flg
4	116-9134	1	Platform ASM W/Decal & Rocker	19	3256-24	4	Washer-3/8 SAE
5	116-7300	1	Access Cover ASM	21	126-6752	2	Screw-Thumb
5:2	121-6163	1	Decal-Tine Ground Operation (CE)	22	614672	2	Screw-Shoulder 3/8-16 X 1.295
6	116-8258	1	Muffler Guard ASM	23	1-811010	2	Plug
6:2	115-2047	2	Decal-Surface, Hot	24	3256-6	2	Washer
8	99-5107	4	Nut-Lock 1/2-13	32	126-7033	1	Decal-Aerator 30 Logo
9	126-0015	2	Grommet	33	117-2718	1	Decal-Arrester, Spark
10	116-6612-01	1	Guard-Chain, RH	34	3290-461	2	Washer-Spring Disc
				35	323-6	4	Screw-HH 3/8-16 X 1

● Not serviced separately

Main Frame Assembly

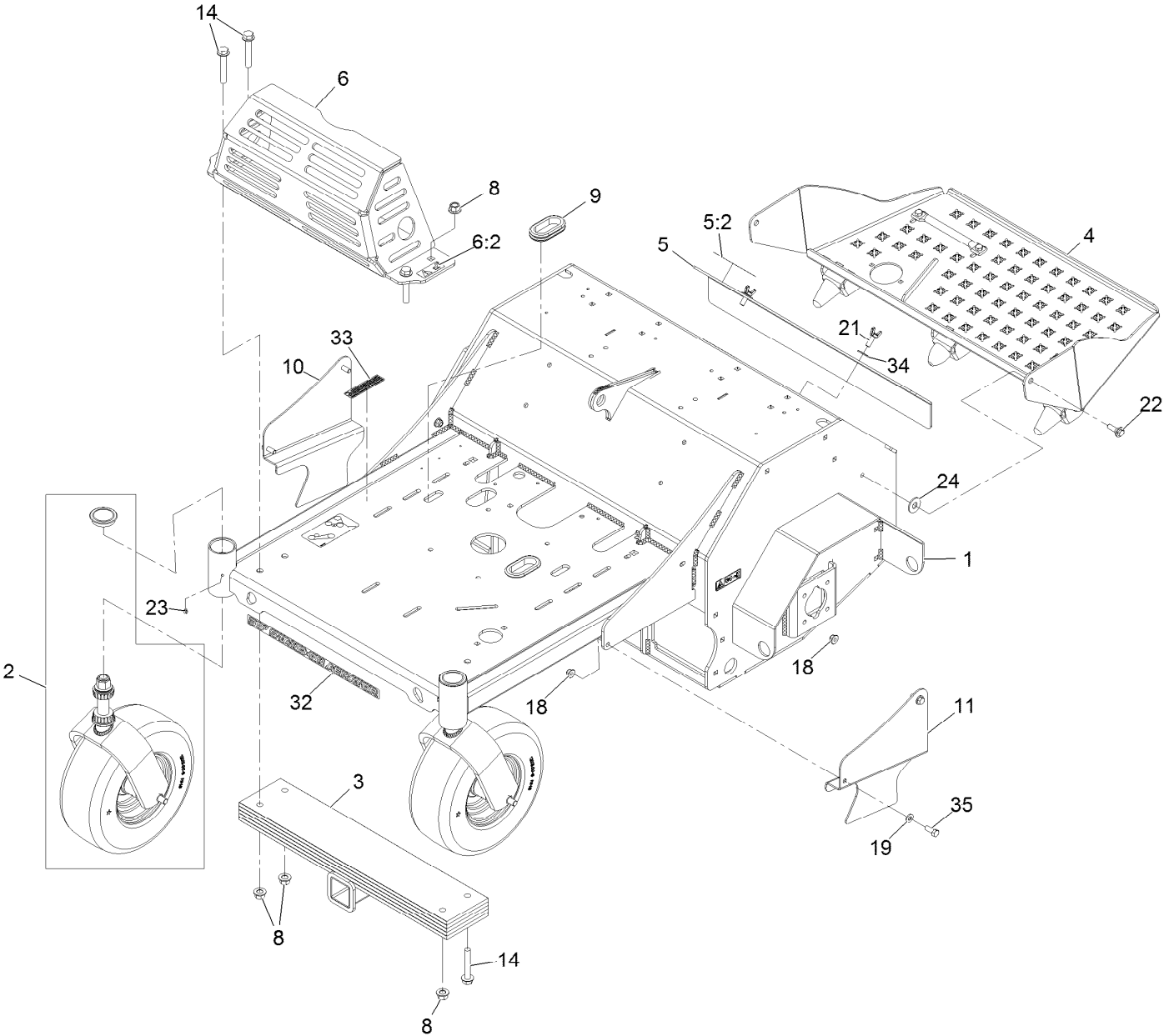

Main Frame Assembly (continued)

<i>Ref.</i>	<i>Part Number</i>	<i>Qty.</i>	<i>Description</i>	<i>Ref.</i>	<i>Part Number</i>	<i>Qty.</i>	<i>Description</i>
1	135-2517	1	Frame-Main W/Symbol Decals	11	116-6611-01	1	Guard-Chain, LH
2		2	Front Caster ASM W/Fork ●	14	3234-40	4	Screw-HF
3	116-6536-01	1	Weight	18	104-8301	6	Nut-Nyloc 3/8-16 Flg
4	116-9134	1	Platform ASM W/Decal & Rocker	19	3256-24	4	Washer-3/8 SAE
5	116-7300	1	Access Cover ASM	21	126-6752	2	Screw-Thumb
5:2	121-6163	1	Decal-Tine Ground Operation (CE)	22	614672	2	Screw-Shoulder 3/8-16 X 1.295
6	116-8258	1	Muffler Guard ASM	23	1-811010	2	Plug
6:2	115-2047	2	Decal-Surface, Hot	24	3256-6	2	Washer
8	99-5107	4	Nut-Lock 1/2-13	32	126-7033	1	Decal-Aerator 30 Logo
9	126-0015	2	Grommet	33	117-2718	1	Decal-Arrester, Spark
10	116-6612-01	1	Guard-Chain, RH	34	3290-461	2	Washer-Spring Disc
				35	323-6	4	Screw-HH 3/8-16 X 1

● Not serviced separately

Main Frame Decal Assembly

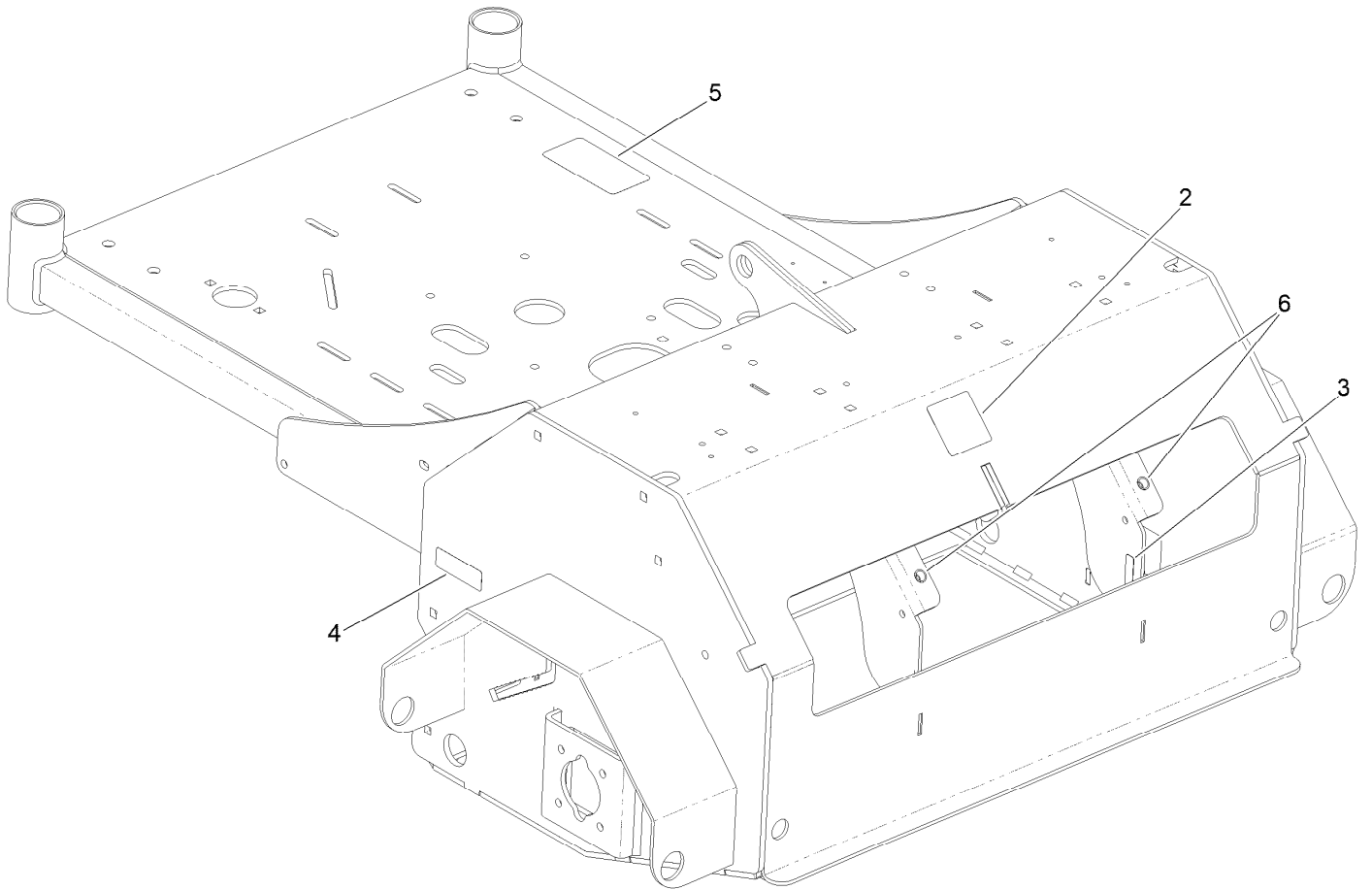

Main Frame Decal Assembly (continued)

<i>Ref.</i>	<i>Part Number</i>	<i>Qty.</i>	<i>Description</i>	<i>Ref.</i>	<i>Part Number</i>	<i>Qty.</i>	<i>Description</i>
2	121-6150	1	Decal-Warning	5	116-9391	1	Decal-Belt Routing
3	120-9570	1	Decal-Warning	6	32148-10	2	Insert-Nut
4	121-6161	2	Decal-Danger				

Caster Wheel and Fork Assembly

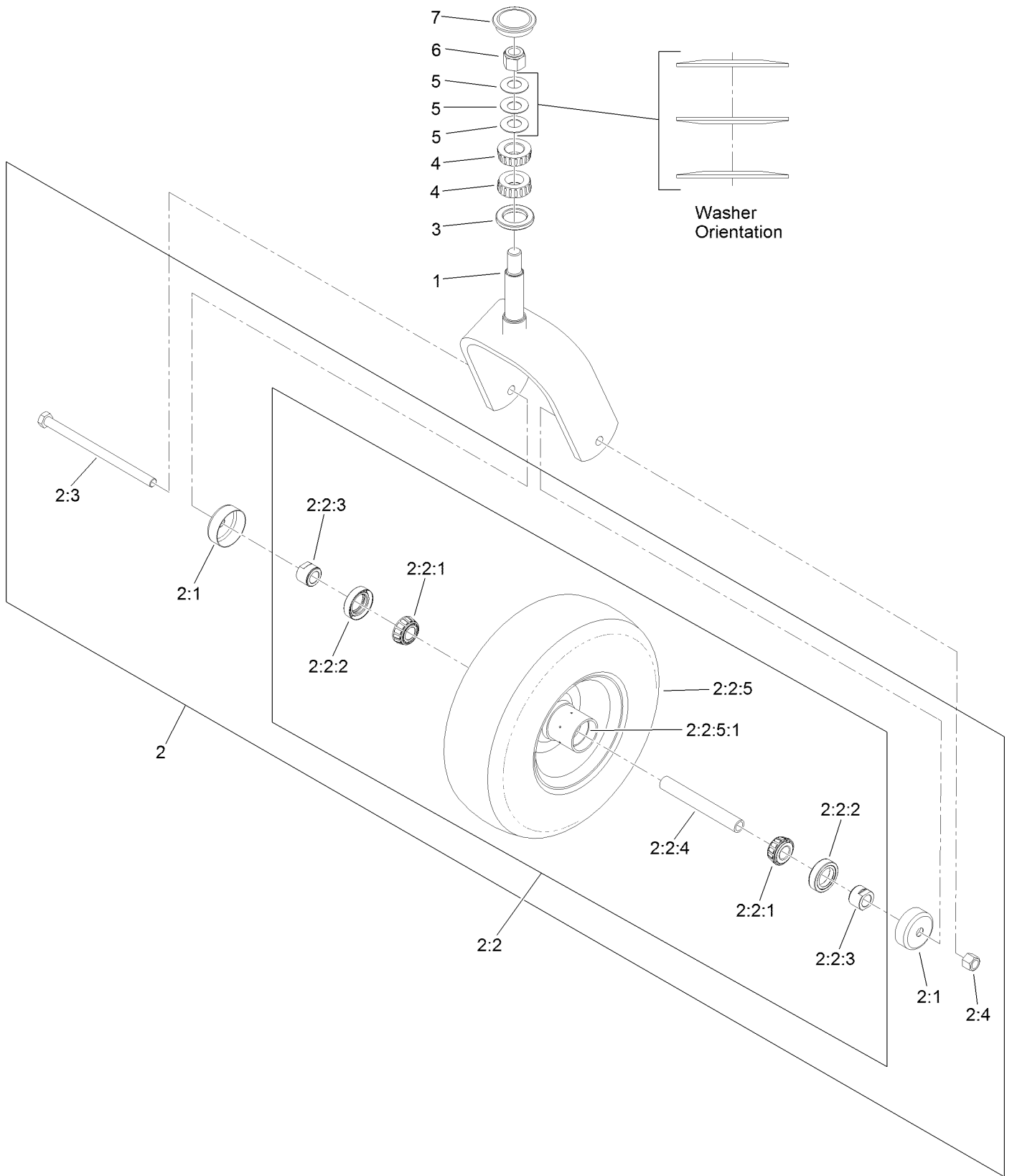

Caster Wheel and Fork Assembly (continued)

<i>Ref.</i>	<i>Part Number</i>	<i>Qty.</i>	<i>Description</i>	<i>Ref.</i>	<i>Part Number</i>	<i>Qty.</i>	<i>Description</i>
1	116-6704-01	1	Caster	2:2:5:1	1-633584	2	Bearing-Cup
2	109-9126	1	Wheel & Tire ASM	2:3	325-42	1	Screw-HH
2:1	103-2768	2	Guard-Seal	2:4	3296-23	1	Nut-Lock, NI
2:2		1	Wheel And Tire ASM ●	3	116-5647	1	Seal-Grease
2:2:1	1-633585	2	Bearing-Cone, Taper	4	1-543509	2	Bearing-Roller, Tapered
2:2:2	103-0063	2	Seal-Caster	5	1-633508	3	Washer-Bellville
2:2:3	103-3051	1	Spacer-Nut ■	6	3296-51	1	Nut-Lock, NI
2:2:4	126-5360	1	Axle-Caster	7	103-4882	1	Cap-Grease
2:2:5		1	Wheel And Tire ASM ●				

● Not serviced separately

■ Use Pro-Lock, Nut Type (P/N 1-840022, .5ml tube) on threads.

Platform and Rocker Assembly

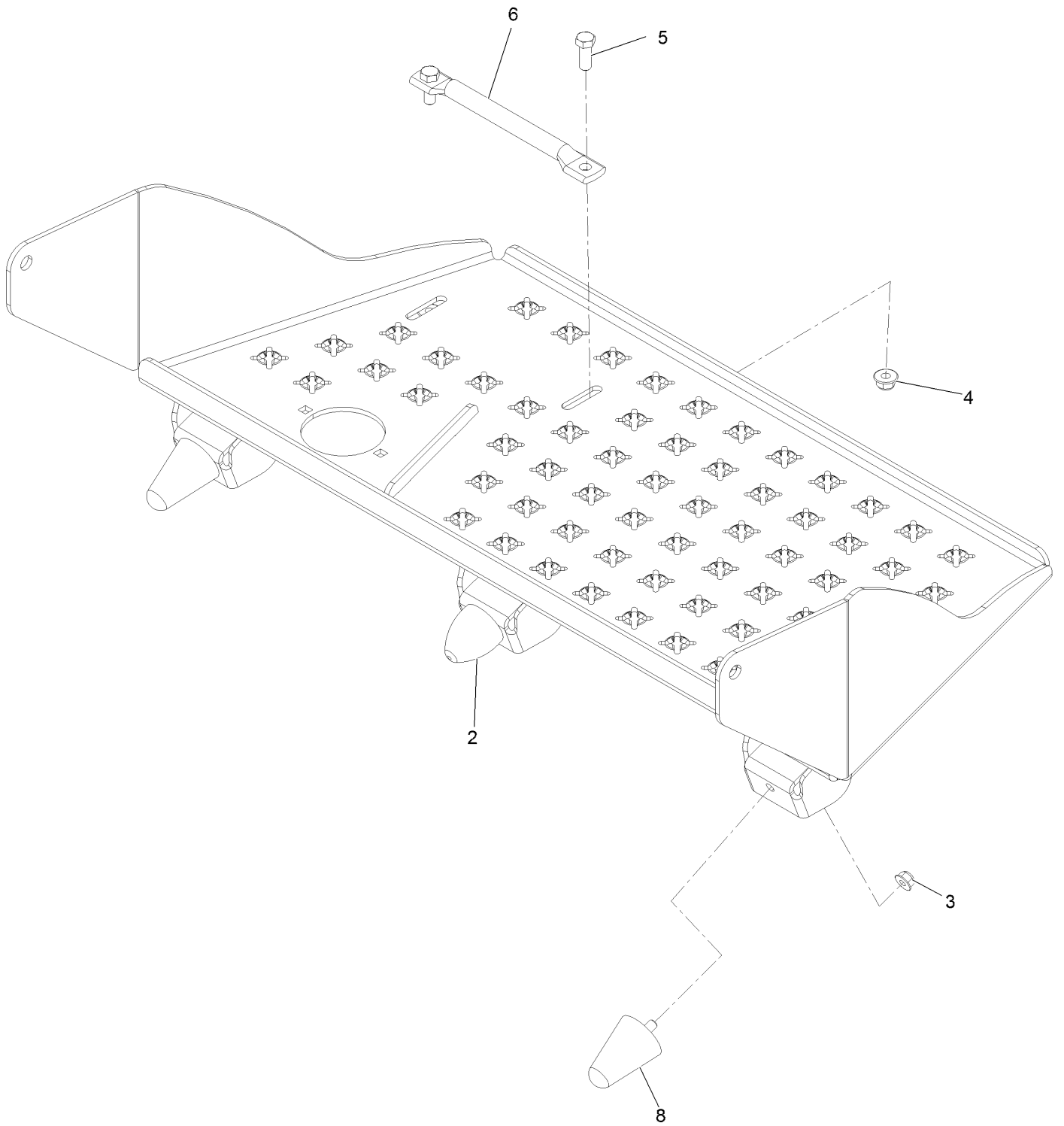

Platform and Rocker Assembly (continued)

<i>Ref.</i>	<i>Part Number</i>	<i>Qty.</i>	<i>Description</i>	<i>Ref.</i>	<i>Part Number</i>	<i>Qty.</i>	<i>Description</i>
2	114-1926	1	Bumper-Rubber	5	323-6	2	Screw-HH 3/8-16 X 1
3	104-8300	3	Nut-Nyloc 5/16-18 Flg	6	116-8950-03	1	Rocker-Foot Pedal
4	104-8301	2	Nut-Nyloc 3/8-16 Flg	8	114-1925	2	Bumper-Rubber

Tower Assembly

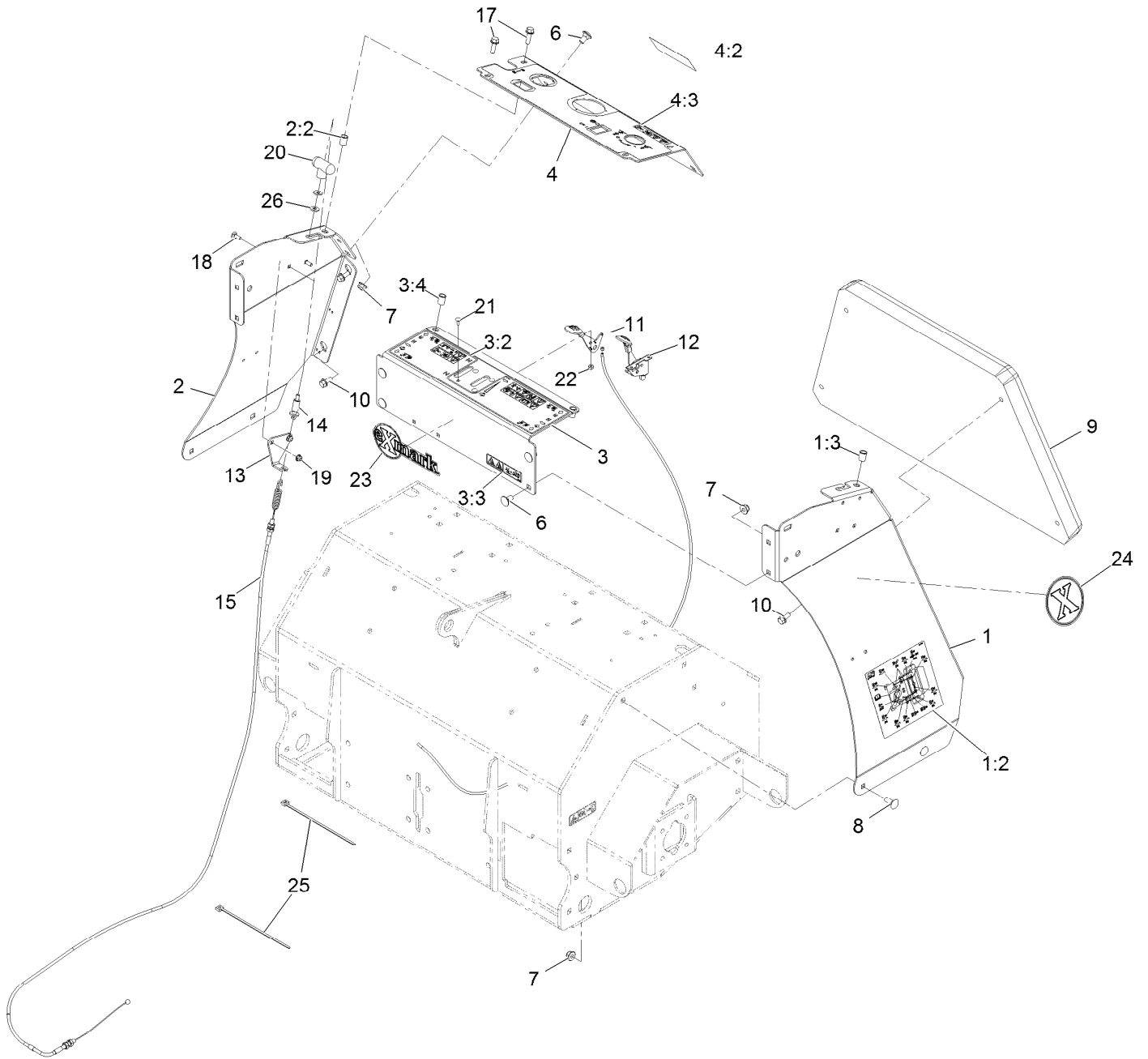

Tower Assembly (continued)

<i>Ref.</i>	<i>Part Number</i>	<i>Qty.</i>	<i>Description</i>	<i>Ref.</i>	<i>Part Number</i>	<i>Qty.</i>	<i>Description</i>
1	116-9386	1	Panel-Side,LH W/Decals-Black	9	116-6765	1	Cushion, Grey
1:2	116-9392	1	Decal-Service Aid CE	10	3234-5	4	Screw-HH Flg 5/16-18 X 3/4
1:3	32148-7	1	Nut-Insert	11	109-9147	1	Control-Choke
2	116-7658	1	ASM-Panel,Side RH (Black)	12	109-3958	1	Control-Throttle
2:2	32148-7	1	Nut-Insert	13	116-6630	1	Bracket-Cable, Brake
3	126-4525	1	ASM-Plate W/Decal	14	116-7504	1	Link-Cable, Brake
3:2	121-6164	1	Decal-Warning, Control Panel	15	116-7503	1	Cable-Brake
3:3	121-6162	1	Decal-Warning, Tines	17	3234-29	4	Screw-HH Flg 5/16-18 X 1
3:4	32148-7	2	Nut-Insert	18	3229-1	2	Bolt-Carriage 1/4-20 X 3/4
4	126-4524	1	ASM-Panel W/Decals	19	104-7201	2	Nut-Nyloc 1/4-20 Flg
4:2	135-2841	1	Decal-Warning	20	116-7607	1	Knob-Tee
4:3	126-4528	1	Decal-Danger, Control Panel	21	1-807513	4	Bolt-Carriage #10-24 X 1/2
6	3231-1	6	Bolt-Carriage 3/8-16 X 3/4	22	3296-2	4	Nut-Nyloc #10-24
7	104-8301	10	Nut-Nyloc 3/8-16 Flg	23	126-6877	1	Decal, Exmark Logo
8	3231-2	4	Bolt-Carriage 3/8-16 X 1	24	126-7457	2	Decal-X-Logo
				25	1-303335	2	Tie-Cable 7 15/16 (Large)
				26	3256-2	2	Washer-1/4 Std

Motion Control Assembly

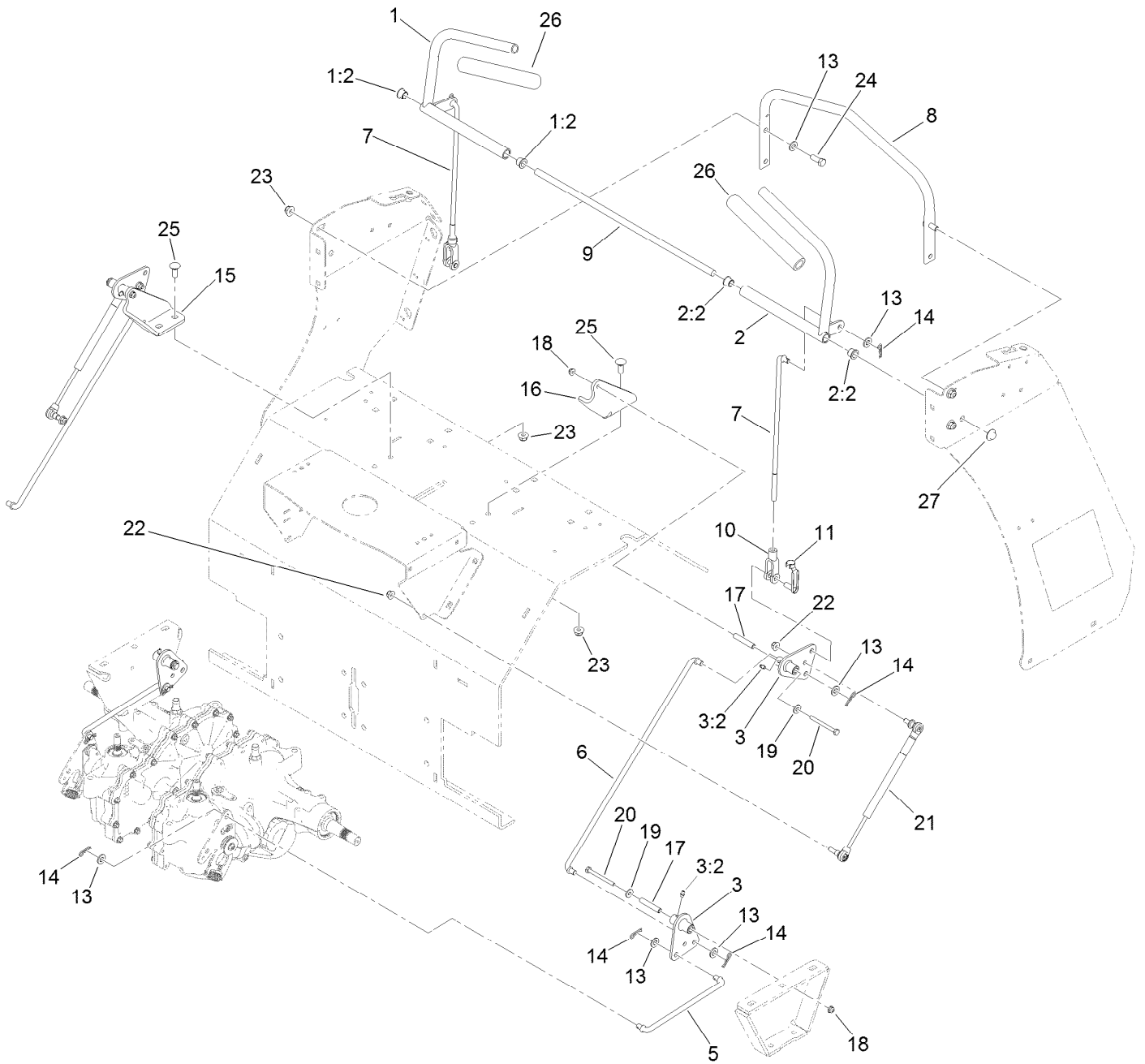

Motion Control Assembly (continued)

<i>Ref.</i>	<i>Part Number</i>	<i>Qty.</i>	<i>Description</i>	<i>Ref.</i>	<i>Part Number</i>	<i>Qty.</i>	<i>Description</i>
1	116-6567	1	RH Control Handle ASM	14	1-806003	10	Pin-Cotter
1:2	116-4279	2	Bearing-Flange	15	116-6576-03	1	Bracket-Pivot, RH
2	116-6566	1	LH Control Handle ASM	16	116-6577-03	1	Bracket-Pivot, LH
2:2	116-4279	2	Bearing-Flange	17	116-7224	4	Spacer
3	126-0340	4	Crank-Bell	18	104-7201	4	Nut-HF
3:2	302-19	1	Fitting-Grease	19	3256-2	4	Washer-Flat
5	116-6722	2	Link-Control, Hydro	20	321-14	4	Screw-HH
6	116-9298	2	Link-Control, Bell Crank	21	116-0027	2	Damper-Control, Motion
7	116-6730	2	Link-Control, Bell Crank	22	104-8300	4	Nut-HF, NI
8	116-6608-03	1	Bar-Reference	23	104-8301	8	Nut-HF, NI
9	116-6607	1	Shaft-Pivot, Control	24	323-6	4	Screw-HH
10	1-633131	2	Yoke-Linkage, Brake	25	3231-2	4	Bolt-CARR
11	103-2399	2	Pin-Spring, Clevis	26	103-8153	2	Grip-Lever, Control
13	3256-24	14	Washer-Flat	27	32112-14	2	Nut-Push

Engine Assembly

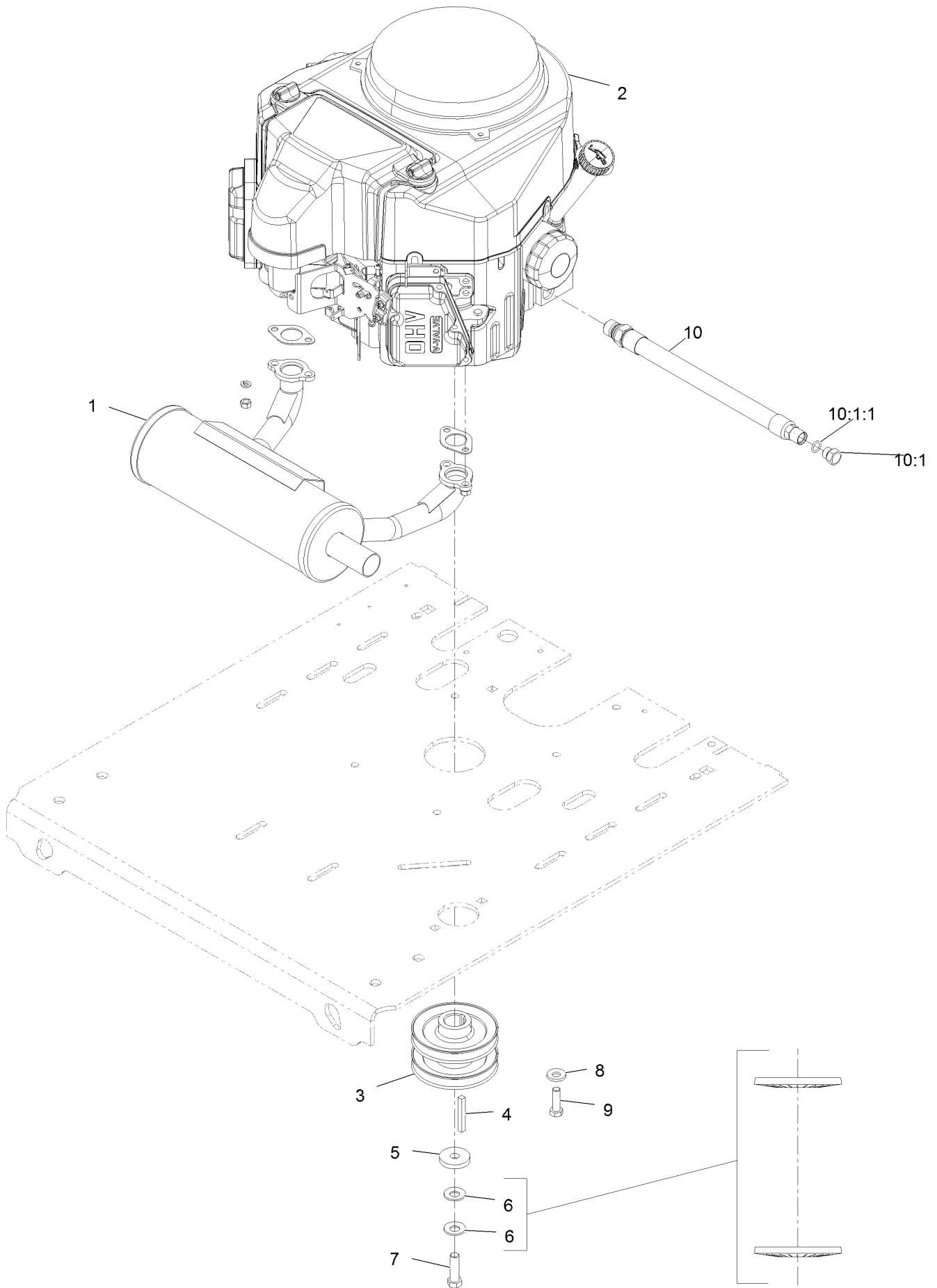

Engine Assembly (continued)

<i>Ref.</i>	<i>Part Number</i>	<i>Qty.</i>	<i>Description</i>	<i>Ref.</i>	<i>Part Number</i>	<i>Qty.</i>	<i>Description</i>
1	116-3735	1	Muffler-Horizontal	8	98-5975	4	Washer-Spring Disc 3/8
2		1	Engine-Kawasaki, Fs541 ■▲	9	323-7	4	Screw-HH 3/8-16 X 1 1/4
3	116-9709	1	Pulley	10	116-4924	1	Asm-Hose Oil Drain W/Plug ◆
4	103-4177	1	Key	10:1	353-508	1	Plug-W/O-Ring ●
5	1-543610	1	Washer	10:1:1	237-42	1	O-Ring
6	1-603610	2	Washer-Spring Disc 7/16				
7	109-9761	1	Screw-HH 7/16-20 X 1 1/2 W/Loctite □				

● Torque to 24-26 ft-lb

▲ Obtain parts from www.kawpowerepc.com

◆ Use a Teflon Pipe Sealant or equivalent on threads.

□ Use Pro-Lock, Nut Type (P/N 1-840022, .5ml tube) on threads.

■ Not serviced separately

Fuel Assembly (continued)

<i>Ref.</i>	<i>Part Number</i>	<i>Qty.</i>	<i>Description</i>	<i>Ref.</i>	<i>Part Number</i>	<i>Qty.</i>	<i>Description</i>
1	116-9541-01	1	Support-Tank, Fuel	11	119-7856	1	Hose-Fuel
2	126-9062	1	Fuel Tank ASM	12	1-603770	1	Valve-Fuel
2:1	126-8886	1	Tank-Fuel 5 Gal	13	135-0494	1	Hose-Line, Gas
2:2	135-0330	1	Cap-Fuel, Ratcheting (3.5 Inch)	17	1-303335	3	Tie-Cable 7 15/16 (Large)
2:3	114-0284	1	Grommet	19	114-0292	1	Bracket-Canister, Carbon
2:4	119-3547	1	Valve-Vent, Fuel	20	117-1221	1	Canister-Carbon, 800Cc
2:5	46-6560	1	Bushing	21	115-0962	1	Hose-Vent, Canister
2:6	109-9364	1	Fitting-Fuel (W/Line And Screen)	22	135-0986	1	Hose-Emissions
3	107-4543	2	Clamp	23	126-4179	1	Hose-Vent, Formed
5	3256-3	2	Washer-5/16 Std	24	119-8501	1	Hose-Vent, Formed
6	322-10	2	Screw-HH 5/16-18 X 2	25	116-2232	1	Valve-Control, Vacuum
7	104-8300	2	Nut-Nyloc 5/16-18 Flg	26	119-8502	1	Hose-Vent, Formed
8	3231-22	4	Bolt-Carriage 3/8-16 X 1	27	126-2991-03	1	Bracket-Mounting, Canister
9	104-8301	4	Nut-Nyloc 3/8-16 Flg	28	3229-1	2	Bolt-Carriage 1/4-20 X 3/4
10	2412-98	4	Clamp-Hose	29	321-2	2	Screw-HH 1/4-20 X 1/2
				30	104-7201	4	Nut-Nyloc 1/4-20 Flg
				31	116-2469	1	Strap-Velcro, Cable Tie

Auxiliary Hydraulic Assembly

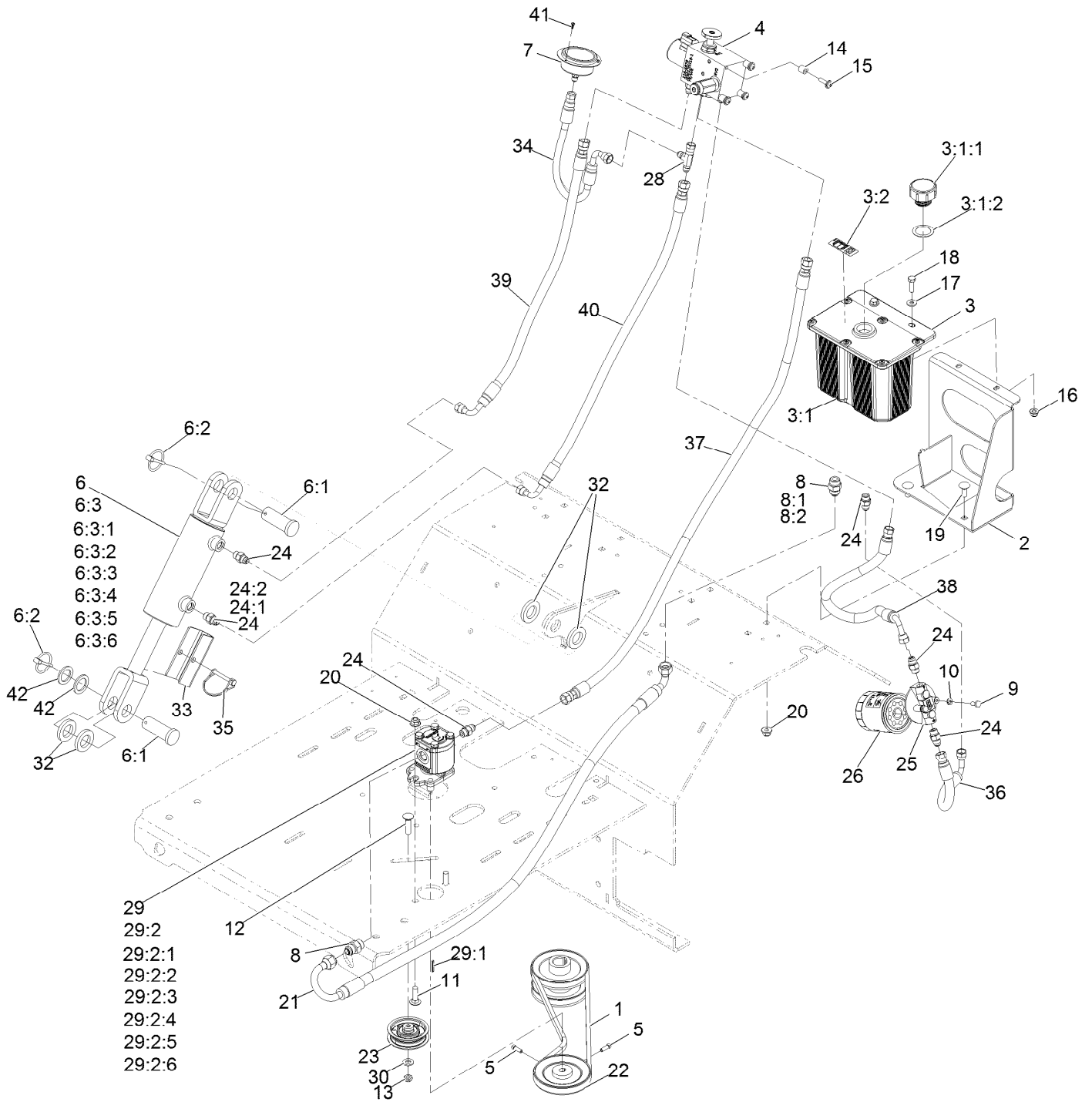

Auxiliary Hydraulic Assembly (continued)

<i>Ref.</i>	<i>Part Number</i>	<i>Qty.</i>	<i>Description</i>	<i>Ref.</i>	<i>Part Number</i>	<i>Qty.</i>	<i>Description</i>
1	116-8874	1	Belt-4L Section	19	3231-2	4	Bolt-Carriage 3/8-16 X 1
2	116-6618-03	1	Bracket-Tank, Hydraulic	20	104-8301	6	Nut-Nyloc 3/8-16 Flg
3	116-7557	1	Reservoir ASM	21	116-9309	1	Hose-Hydraulic
3:1		1	Tank-Hydraulic ●	22	116-6667	1	Pulley
3:1:1	103-1948	1	Cap-Reservoir, HYD	23	116-6760	1	Pulley-Idler, Flat
3:1:2	103-1949	1	Gasket-Cap	24	103-2156	6	Adapter-Straight
3:2	93-6686	1	Decal-Oil, HYD	24:1	1-603921	1	O-Ring-SAE #6
4	116-9549	1	Valve-Manifold	24:2	103-1020	1	O-Ring-37 Flare #6
5	3241-6	2	Screw-SQH ■	25	104-7836	1	Filter-Head
6	116-6969	1	HYD Cylinder ASM	26	109-4180	1	Element, Oil Filter
6:1	116-7290	2	Pin-Clevis	28	353-877	1	Fitting-HYD, Tee
6:2	92-1298	2	Pin-Lynch	29	116-9129	1	Hydraulic Pump ASM
6:3	127-3234	1	Seal Kit	29:1	115-7855	1	Key-Square
6:3:1		1	O-Ring ●	29:2	112-0199	1	Seal Kit
6:3:2		1	Backup Ring ●	29:2:1		1	Seal-Anti Extrusion ●
6:3:3		1	Psp Seal ●	29:2:2		1	Seal-Anti Extrusion ●
6:3:4		1	Bs Seal ●	29:2:3		1	Seal-Shaft ●
6:3:5		1	Dust Seal ●	29:2:4		1	Seal-Upper ●
6:3:6		1	O-Ring ●	29:2:5		1	Seal ●
7	116-8178	1	Gauge-Pressure	29:2:6		2	O-Ring ●
8	1-603990	2	Adapter-Straight	30	3256-24	1	Washer-3/8 SAE
8:1	1-603920	1	O-Ring-SAE #8	32	116-6781	4	Spacer
8:2	1-603992	1	O-Ring-37 Flare #8	33	116-7307-01	1	Stop-Cylinder
9	321-3	2	Screw-HH 1/4-20 X 5/8	34	116-8180	1	Hose-Hydraulic, HP
10	1-805004	2	Washer-Lock 1/4 Heavy	35	112-2583	1	Pin-Locking
11	3231-25	2	Bolt-Carriage 3/8-16 X 1 1/4	36	116-6675	1	Hose-Hydraulic, LP
12	3231-4	1	Bolt-Carriage 3/8-16 X 1 1/2	37	116-8151	1	Hose-Hydraulic
13	3296-59	1	Nut-Nyloc 3/8-16 Thin	38	116-9308	1	Hose-Hydraulic
14	22-7810	4	Spacer	39	116-6677	1	Hose-Hydraulic
15	110-9361	4	Screw-PPH	40	116-6678	1	Hose-Hydraulic, HP
16	104-8300	2	Nut-Nyloc 5/16-18 Flg	41	363-8552	3	Screw-TAP
17	3256-2	2	Washer-1/4 Std	42	3-8514	2	Washer-Thrust
18	322-5	2	Screw-HH 5/16-18 X 1				

● Not serviced separately

■ Use Pro-Lock, Nut Type (P/N 1-840022, .5ml tube) on threads.

Manifold W/Check and Relief Valve Assembly No. 116-9549

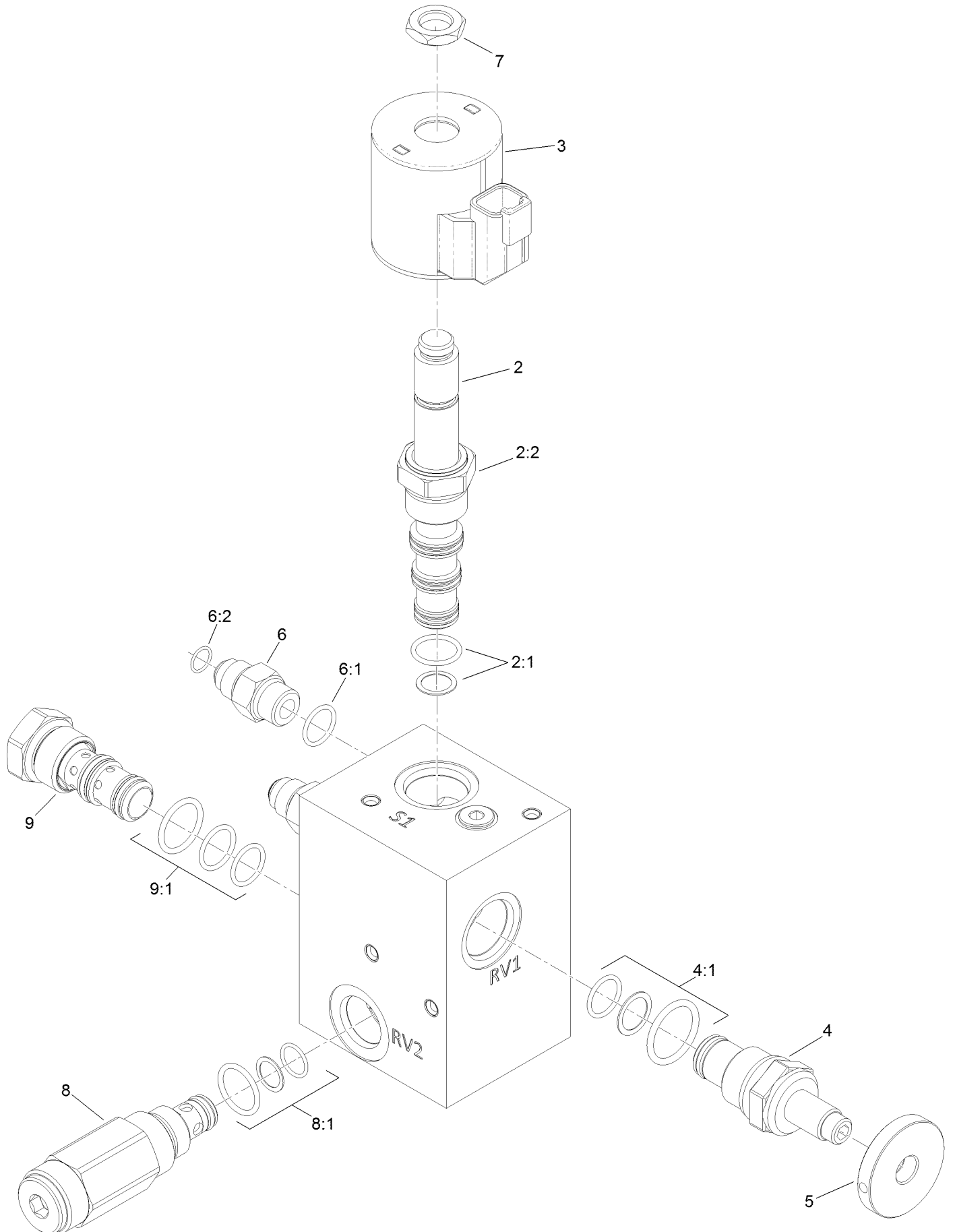

Manifold W/Check and Relief Valve Assembly No. 116-9549 (continued)

<i>Ref.</i>	<i>Part Number</i>	<i>Qty.</i>	<i>Description</i>	<i>Ref.</i>	<i>Part Number</i>	<i>Qty.</i>	<i>Description</i>
2	110-8906	1	Valve-Solenoid	6:1	1-603921	1	O-Ring
2:1	110-8908	1	Spool Valve Seal Kit	6:2	103-1020	1	O-Ring
2:2	110-2634	1	Nut-Coil	7	110-2634	1	Nut-Coil
3	119-4619	1	Coil-Solenoid	8	116-9716	1	Valve-Relief
4	116-9397	1	Valve-Relief, Poppet Style	8:1	116-9717	1	Seal Kit
4:1	116-9398	1	Relief Valve Seal Kit	9	116-9718	1	Valve-Check, P O
5	116-9396	1	Knob (1.5 DIA)	9:1	116-9719	1	Seal Kit
6	103-2156	4	Fitting-Straight				

Ground Drive Assembly

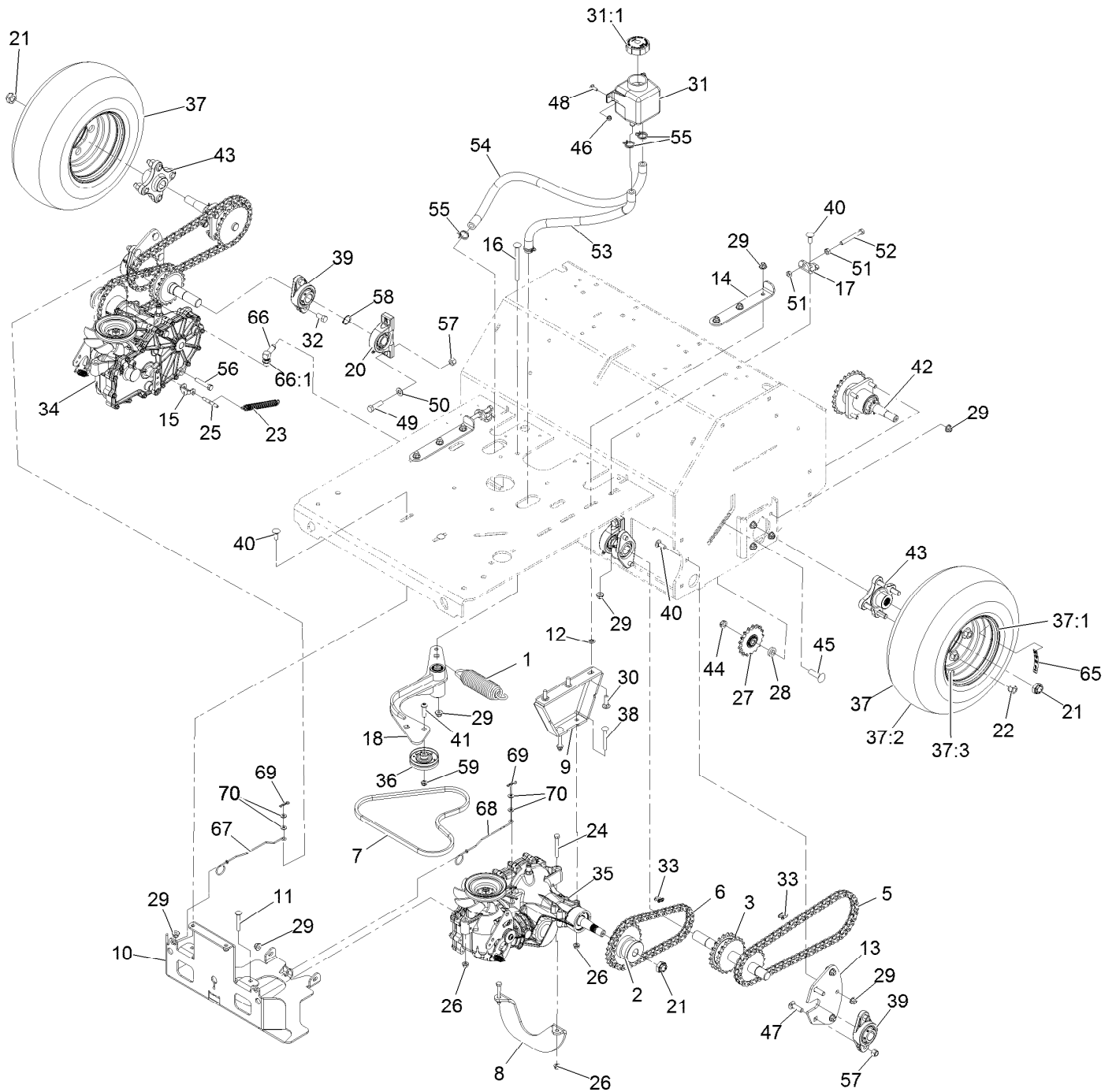

Ground Drive Assembly (continued)

<i>Ref.</i>	<i>Part Number</i>	<i>Qty.</i>	<i>Description</i>	<i>Ref.</i>	<i>Part Number</i>	<i>Qty.</i>	<i>Description</i>
1	116-6317	1	Spring-Extension	36	116-9715	1	Pulley-Idler
2	116-9305	2	Hub-Drive, Chain	37	116-6932	2	Tire ASM (16 X 6.50-8)
3	126-5625	2	Jackshaft	37:1	116-6977	1	Rim (8 X 5.375)
5	126-8808	2	Chain-Roller	37:2	116-6978	1	Tire
6	126-8807	2	Chain-Roller	37:3	232-27	1	Stem-Valve
7	116-8874	1	Belt-4L Section	38	3230-9	4	Bolt-Carriage 5/16-18 X 2 3/4
8	116-9127-03	1	Brace-Angle	39	116-6777	4	Bearing-Flange, 2 Bolt
9	116-9710-03	2	Mount-Transmission	40	3231-2	10	Bolt-Carriage 3/8-16 X 1
10	126-5495-03	1	Guard-Transmission	41	116-9927	1	Screw-HSBH
11	3230-7	2	Bolt-Carriage 5/16-18 X 2 1/4	42	116-9545	2	Axle And Bearing ASM
12	107-3154	6	Nut-Push 3/8-16	43	116-3872	2	Hub-Offset
13	116-6596-01	2	Plate-Jackshaft	44	3296-45	2	Nut-Nyloc 1/2-13 Thin
14	116-6619	2	Plate-Adjustment, Transmission	45	3233-14	2	Screw-CARR
15	116-7597	1	Yoke-Brake, Park	46	104-7201	2	Nut-Nyloc 1/4-20 Flg
16	9000779	1	Bolt-CARR	47	3232-3	4	Bolt-Carriage 7/16-14 X 1 1/2
17	116-6723	2	Bracket-Hydro, Adjust	48	3229-1	2	Bolt-Carriage 1/4-20 X 3/4
18	116-9307	1	Idler Arm ASM	49	324-6	4	Screw-HH 7/16-14 X 1 1/2
20	116-6756	2	Bearing-Pillow Block	50	3256-25	4	Washer-7/16 SAE
21	116-2839	4	Nut-Lock	51	3217-7	4	Nut-Hex 3/8-16
22	242-50	8	Nut-Lug 1/2-20	52	99-8664	2	Bolt-HH 3/8-16 X 3 Tap
23	76-4660	1	Spring-Door	53	116-6775	1	Hose-Hydraulic
24	322-12	2	Screw-HH 5/16-18 X 2 1/2	54	116-6776	1	Hose-Hydraulic
25	116-7596	1	Pin-Brake, Park	55	109-3322	4	Clamp-Hose
26	104-8300	8	Nut-Nyloc 5/16-18 Flg	56	323-10	2	Screw-HH 3/8-16 X 2
27	126-9274	2	Sprocket-Idler	57	3296-48	8	Nut-Nyloc 7/16-14
28	104-8417	2	Washer	58	32151-29	2	Ring-Retaining
29	104-8301	27	Nut-Nyloc 3/8-16 Flg	59	3296-59	1	Nut-Nyloc 3/8-16 Thin
30	3231-25	6	Bolt-Carriage 3/8-16 X 1 1/4	65	126-2054	2	Decal-Hub, Wheel
31	109-2250	1	Vent-Tank, HYD	66	109-6449	1	Fitting-Elbow, 90
31:1	109-3320	1	Cap-Reservoir, HYD	66:1	237-42	1	O-Ring
32	116-7109	4	Screw-HH	67	135-0685	1	Rod-Bypass, RH
33	116-6897	4	Link-Connecting	68	135-0683	1	Rod-Bypass, LH
34	135-1050	1	Transaxle-Zt3100, Rt (W/Pin)	69	1-806003	2	Hairpin-Cotter
35	135-1051	1	Transaxle-Zt3100, Lt (W/Pin)	70	119-8952	4	Washer
				99	109-9828	1	Bottle-Oil, 32Oz Hydraulic●

● Not illustrated

Idler Arm Assembly No. 116-9307

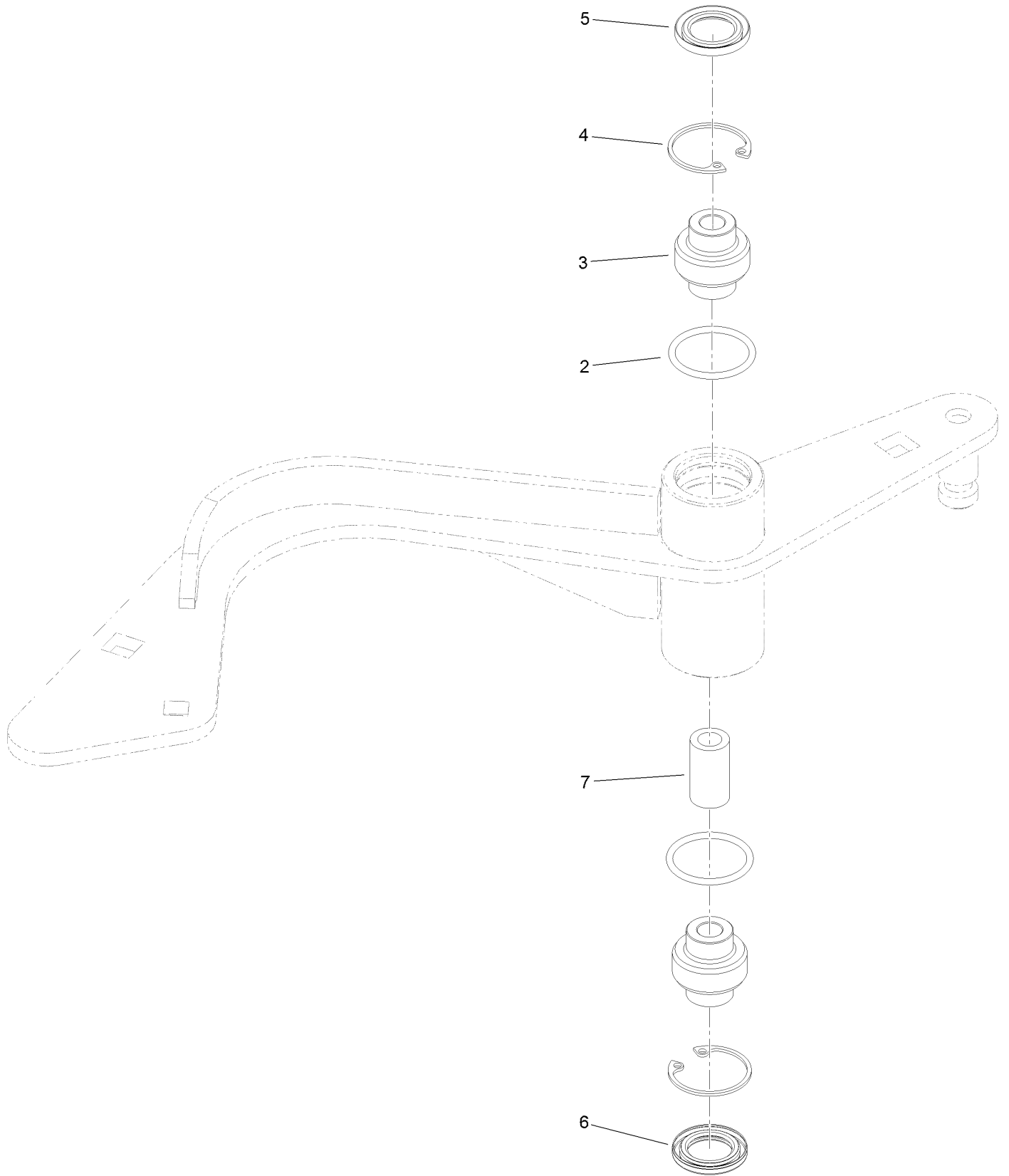

Idler Arm Assembly No. 116-9307 (continued)

<i>Ref.</i>	<i>Part Number</i>	<i>Qty.</i>	<i>Description</i>	<i>Ref.</i>	<i>Part Number</i>	<i>Qty.</i>	<i>Description</i>
2	106-7159	2	O-Ring	5	103-3506	1	Seal-Lip, Single
3	103-3504	2	Bearing-Spherical	6	103-3505	1	Seal-Lip, Double
4	32120-10	2	Ring-Snap	7	1-603401	1	Spacer

Axle and Bearing Assembly No. 116-9545

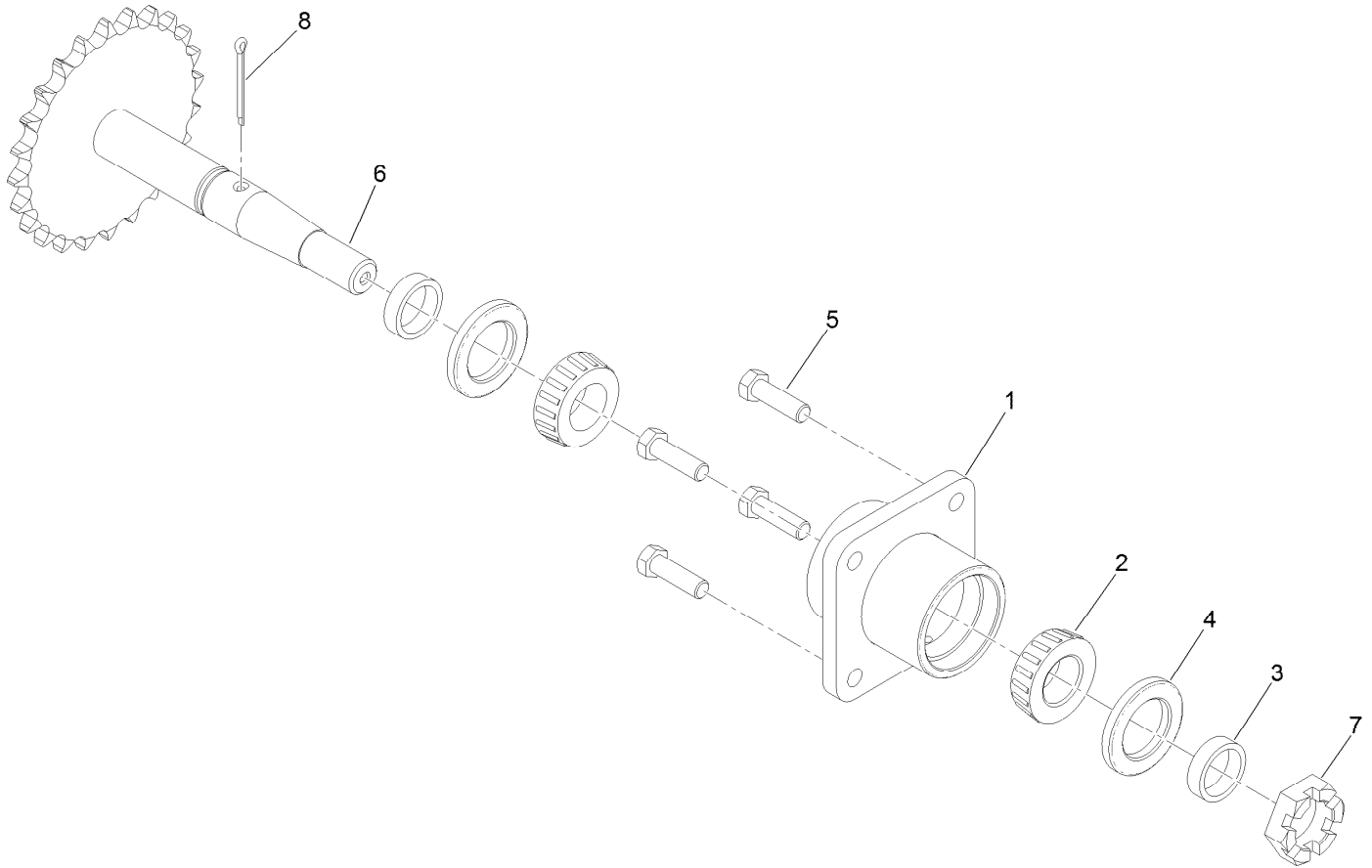

Axle and Bearing Assembly No. 116-9545 (continued)

<i>Ref.</i>	<i>Part Number</i>	<i>Qty.</i>	<i>Description</i>	<i>Ref.</i>	<i>Part Number</i>	<i>Qty.</i>	<i>Description</i>
1	116-6746-01	1	Mount-Bearing, Wheel	5	323-7	4	Screw-HH
2	1-543509	2	Bearing-Roller, Tapered	6	126-0459	1	Axle
3	116-6758	2	Spacer	7	99-3139	1	Nut
4	1-543511	2	Seal-Grease	8	1-806800	1	Pin-Cotter

LH Transaxle Assembly No. 135-1051

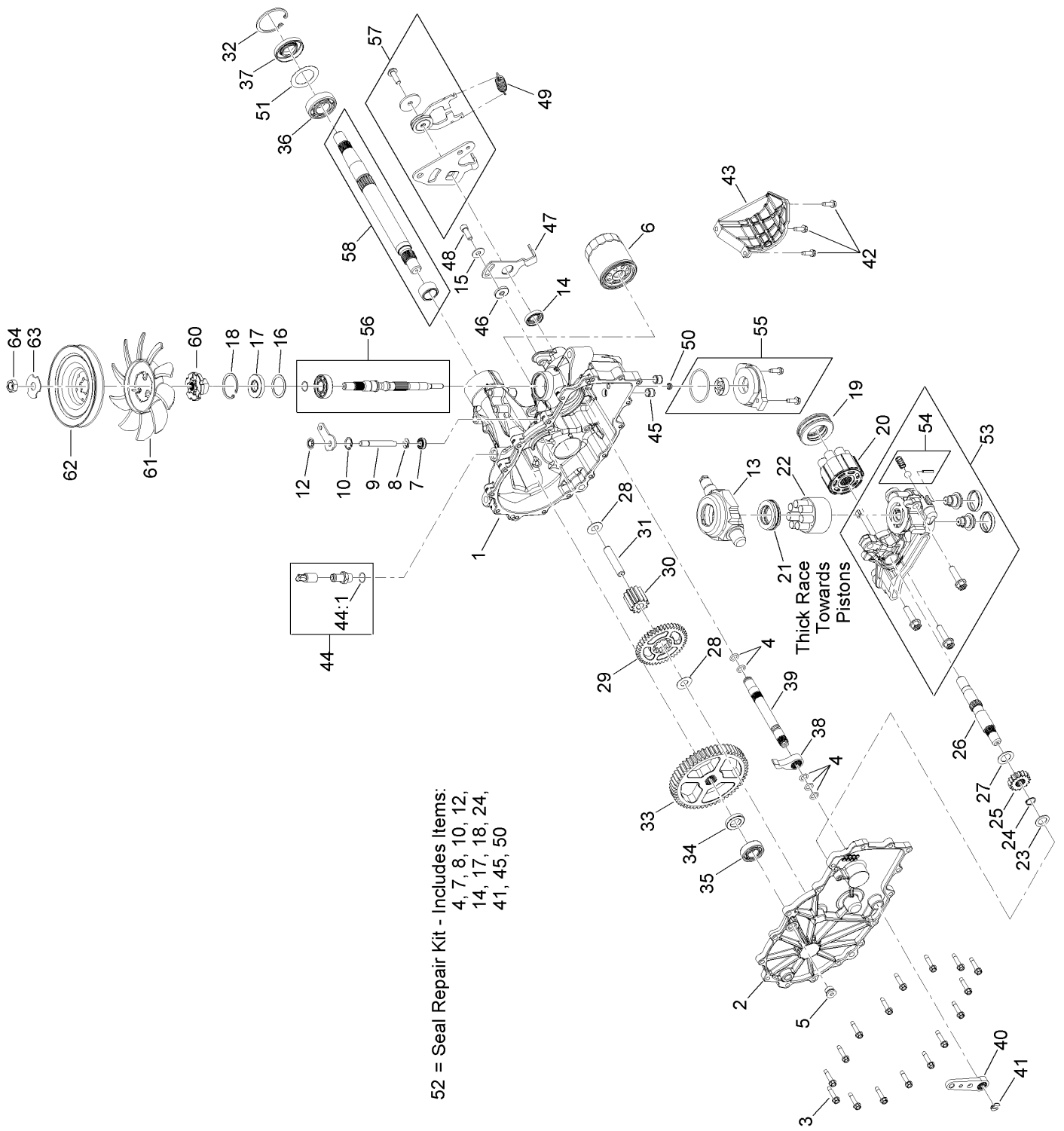

52 = Seal Repair Kit - Includes Items:
 4, 7, 8, 10, 12,
 14, 17, 18, 24,
 41, 45, 50

Thick Race
 Towards
 Pistons

LH Transaxle Assembly No. 135-1051 (continued)

<i>Ref.</i>	<i>Part Number</i>	<i>Qty.</i>	<i>Description</i>	<i>Ref.</i>	<i>Part Number</i>	<i>Qty.</i>	<i>Description</i>
1	114-8471	1	LH Main Housing Kit	34	120-7975	1	Spacer
2	114-8472	1	LH Side Cover Kit	35	135-1361	1	Bearing-Ball
3	117-5359	16	Screw-HHF	36	120-7976	1	Bearing-Ball
4	114-1678	5	O-Ring	37	104-2144	1	Seal
5	135-1140	1	Plug-Straight	38	114-1697	1	Pawl-Brake
6	109-3321	1	Filter-Hydraulic	39	114-1698	1	Shaft-Brake, Inboard
7	106-8676	1	Seal-Lip	40	125-0021	1	Handle-Brake
8	106-8677	1	Ring-Retaining, External	41	131-0906	1	Ring-Retaining, EXT
9	114-1685	1	Rod-Bypass	42	104-2120	3	Screw
10	106-8679	1	Ring-Retaining, Internal	43	120-7979	1	Guard-Filter, LH
12	106-8681	1	Ring-Retaining, External	44	109-3278	1	Adapter-Straight
13	104-5304	1	Swashplate-Trunnion	44:1	237-42	1	O-Ring
14	104-5313	1	Seal-Lip	45	114-8455	2	Tube-Connecting
15	114-8491	1	Washer	46	114-8458	1	Spacer
16	104-5308	1	Spacer	47	114-8474	1	Arm-Neutral, Left
17	104-5310	1	Seal-Lip	48	106-8682	1	Screw-Sh
18	104-5309	1	Ring-Retaining	49	115-8307	1	Spring-Extension
19	109-2865	1	Bearing-Thrust	50	131-0908	1	Seal-Gerotor
20	114-1689	1	Motor Cylinder Block Kit	51	121-5745	1	Spacer
21	94-6922	1	Bearing-Thrust	52	109-3537	1	Seal Kit
22	110-8561	1	Pump Block ASM	53	120-7980	1	LH Center Section Charge Kit
23	104-5339	1	Washer-Flat	54	114-8464	1	Charge Relief Kit
24	104-5340	1	Ring-Retaining	55	114-8465	1	Charge Kit
25	126-0788	1	Gear-16T	56	117-5361	1	Input Shaft Kit
26	114-1691	1	Shaft-Motor	57	126-0790	1	Control Arm Kit
27	104-5360	1	Washer	58	114-8470	1	Axle Shaft Kit
28	94-1933	2	Washer	60	116-9705	1	Hub-Pulley
29	125-0000	1	Gear-43T	61	116-9706	1	Fan
30	120-7974	1	Gear-11T	62	116-9707	1	Pulley
31	104-5329	1	Pin-Jackshaft	63	116-9708	1	Washer-Slotted
32	104-2169	1	Ring-Retaining	64	116-9714	1	Nut-HJ
33	114-1694	1	Gear-54T				

RH Transaxle Assembly No. 135-1050

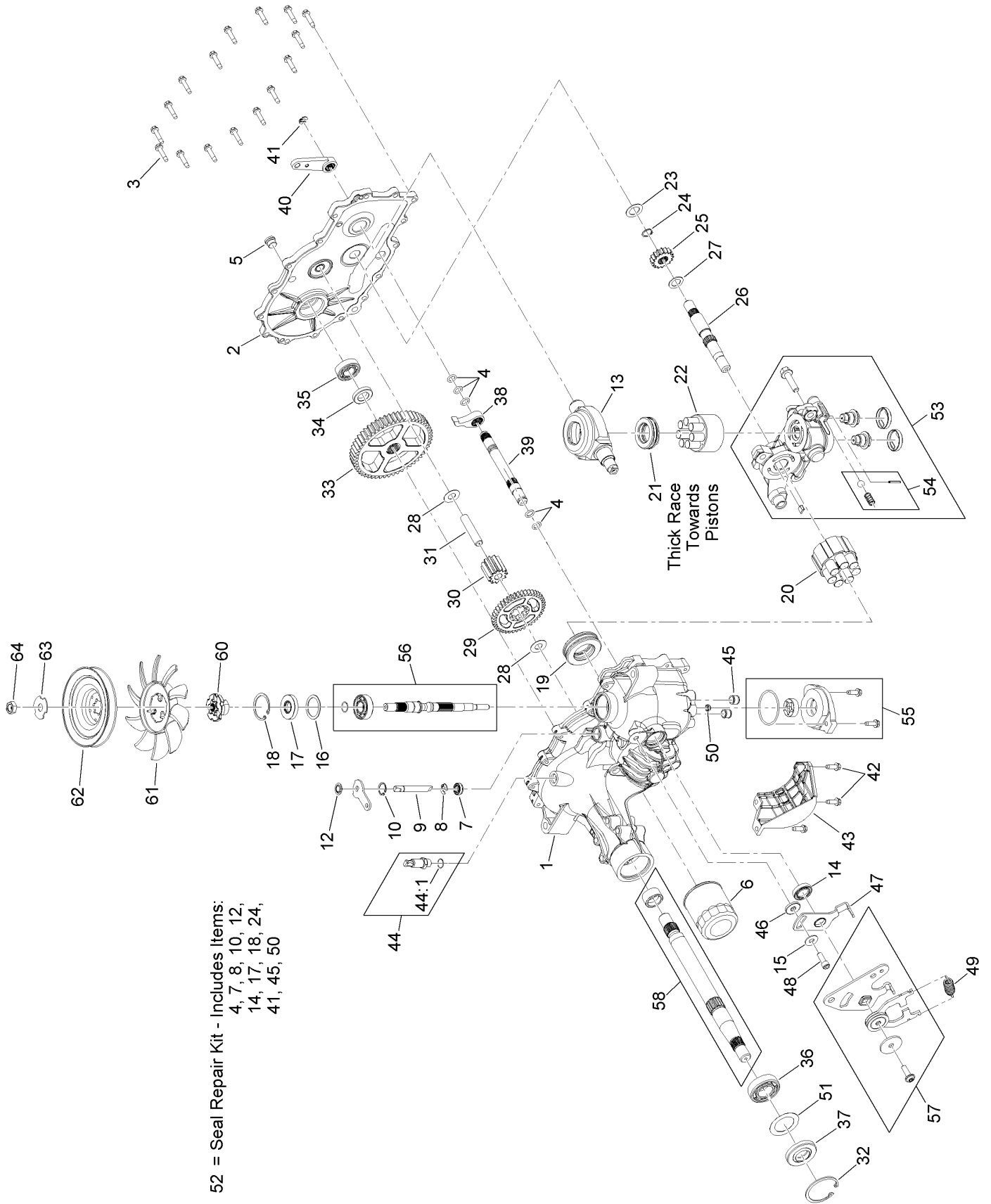

RH Transaxle Assembly No. 135-1050 (continued)

<i>Ref.</i>	<i>Part Number</i>	<i>Qty.</i>	<i>Description</i>	<i>Ref.</i>	<i>Part Number</i>	<i>Qty.</i>	<i>Description</i>
1	114-1676	1	Main Housing Kit	34	120-7975	1	Spacer
2	117-5358	1	RH Housing Side Kit	35	135-1361	1	Bearing-Ball
3	117-5359	16	Screw-HHF	36	120-7976	1	Bearing-Ball
4	114-1678	5	O-Ring	37	104-2144	1	Seal
5	135-1140	1	Plug-Straight	38	114-1697	1	Pawl-Brake
6	109-3321	1	Element-Oil Filter, HYD	39	114-1698	1	Shaft-Brake, Inboard
7	106-8676	1	Seal-Lip	40	125-0021	1	Handle-Brake
8	106-8677	1	Ring-Retaining, External	41	131-0906	1	Ring-Retaining, EXT
9	114-1685	1	Rod-Bypass	42	104-2120	3	Screw
10	106-8679	1	Ring-Retaining, Internal	43	120-7981	1	Guard-Filter, RH
12	106-8681	1	Ring-Retaining, External	44	109-3278	1	Adapter-Straight
13	104-5304	1	Swashplate-Trunnion	44:1	237-42	1	O-Ring
14	104-5313	1	Seal-Lip	45	126-3251	2	Tube-Charge
15	114-8491	1	Washer	46	114-8458	1	Spacer
16	104-5308	1	Spacer	47	114-8459	1	Arm-Neutral, Right
17	104-5310	1	Seal-Lip	48	106-8682	1	Screw-Sh
18	104-5309	1	Ring-Retaining	49	115-8307	1	Spring-Extension
19	109-2865	1	Bearing-Thrust	50	131-0908	1	Seal-Gerotor
20	114-1689	1	Motor Cylinder Block Kit	51	121-5745	1	Spacer
21	94-6922	1	Bearing-Thrust	52	109-3537	1	Seal Kit
22	110-8561	1	Pump Block ASM	53	120-7982	1	RH Center Section Charge Kit
23	104-5339	1	Washer-Flat	54	114-8464	1	Charge Relief Kit
24	104-5340	1	Ring-Retaining	55	114-8465	1	Charge Kit
25	126-0788	1	Gear-16T	56	117-5361	1	Input Shaft Kit
26	114-1691	1	Shaft-Motor	57	126-2291	1	Control Arm Kit
27	104-5360	1	Washer	58	114-8470	1	Axle Shaft Kit
28	94-1933	2	Washer	60	116-9705	1	Hub-Pulley
29	125-0000	1	Gear-43T	61	116-9706	1	Fan
30	120-7974	1	Gear-11T	62	116-9707	1	Pulley
31	104-5329	1	Pin-Jackshaft	63	116-9708	1	Washer-Slotted
32	104-2169	1	Ring-Retaining	64	116-9714	1	Nut-HJ
33	114-1694	1	Gear-54T				

Tine Assembly

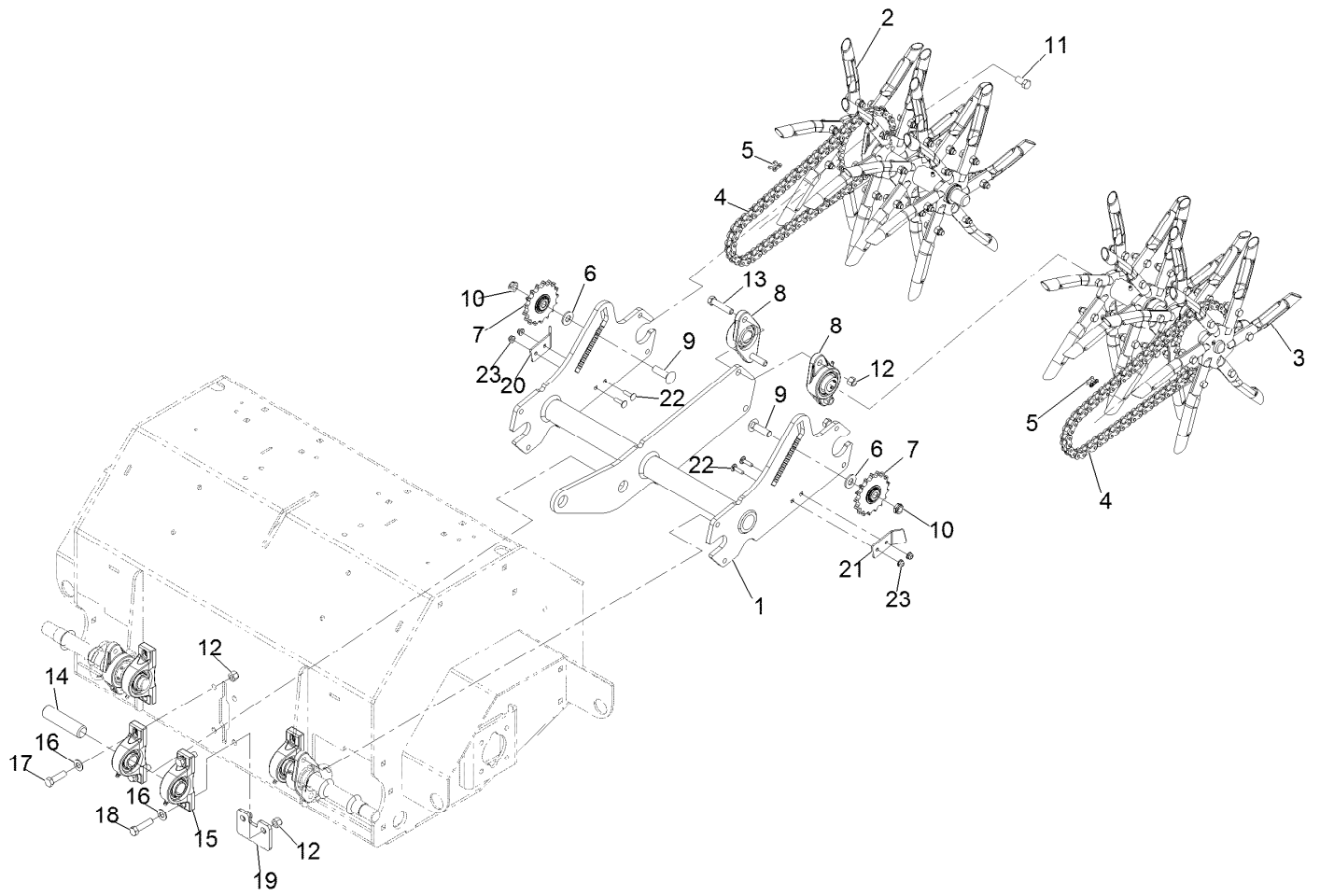

Tine Assembly (continued)

<i>Ref.</i>	<i>Part Number</i>	<i>Qty.</i>	<i>Description</i>	<i>Ref.</i>	<i>Part Number</i>	<i>Qty.</i>	<i>Description</i>
1	126-4817-03	1	Arm-Trail	13	324-8	2	Screw-HH
2	116-6738	1	RH Tine Wheel ASM	14	116-6629	1	Shaft
3	116-6739	1	LH Tine Wheel ASM	15	116-6756	2	Bearing-Pillow Block ●
4	126-8808	2	Chain-Roller	16	3256-25	4	Washer-7/16 SAE
5	116-6897	2	Link-Connecting	17	324-6	2	Screw-HH 7/16-14 X 1 1/2
6	87-7270	2	Washer-Thrust	18	324-7	2	Screw-HH
7	126-9274	2	Sprocket-Idler	19	116-7327-01	1	Plate-Downstop
8	116-6777	2	Bearing-Flange, 2 Bolt	20	126-4192-03	1	Guard-Chain, RH
9	3233-14	2	Screw-CARR	21	126-4193-03	1	Guard-Chain, LH
10	3296-45	2	Nut-Nyloc 1/2-13 Thin	22	3229-30	4	Bolt-Carriage 1/4-20 X 1
11	116-7109	4	Screw-HH ●	23	104-7201	4	Nut-Nyloc 1/4-20 Flg
12	3296-48	6	Nut-Nyloc 7/16-14				

● Use Pro-Lock, Nut Type (P/N 1-840022, .5ml tube) on threads.

LH Tine Wheel Assembly No. 116-6739

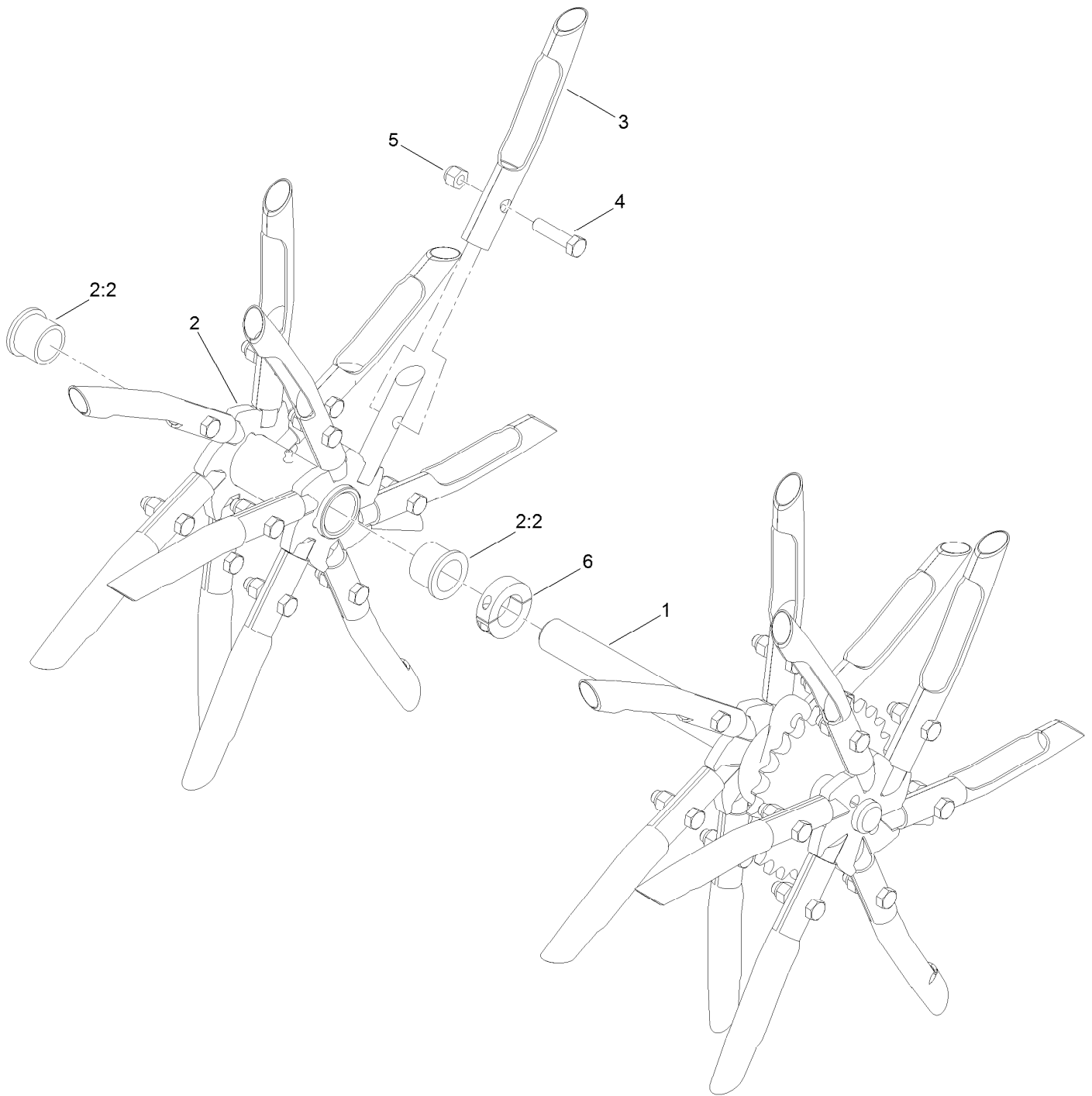

LH Tine Wheel Assembly No. 116-6739 (continued)

<i>Ref.</i>	<i>Part Number</i>	<i>Qty.</i>	<i>Description</i>	<i>Ref.</i>	<i>Part Number</i>	<i>Qty.</i>	<i>Description</i>
1	116-6728	1	Shaft-Tine, LH	4	323-8	24	Screw-HH
2	116-6731	1	Float Tine Shaft ASM	5	3296-39	24	Nut-Lock, NI
2:2	94-8949	2	Bushing-Flange	6	116-7271	1	Collar-Locking ●
3	126-2143	24	Tine-Coring (3/4 Inch)				

● Use Loctite® 243 on threads.

RH Tine Wheel Assembly No. 116-6738

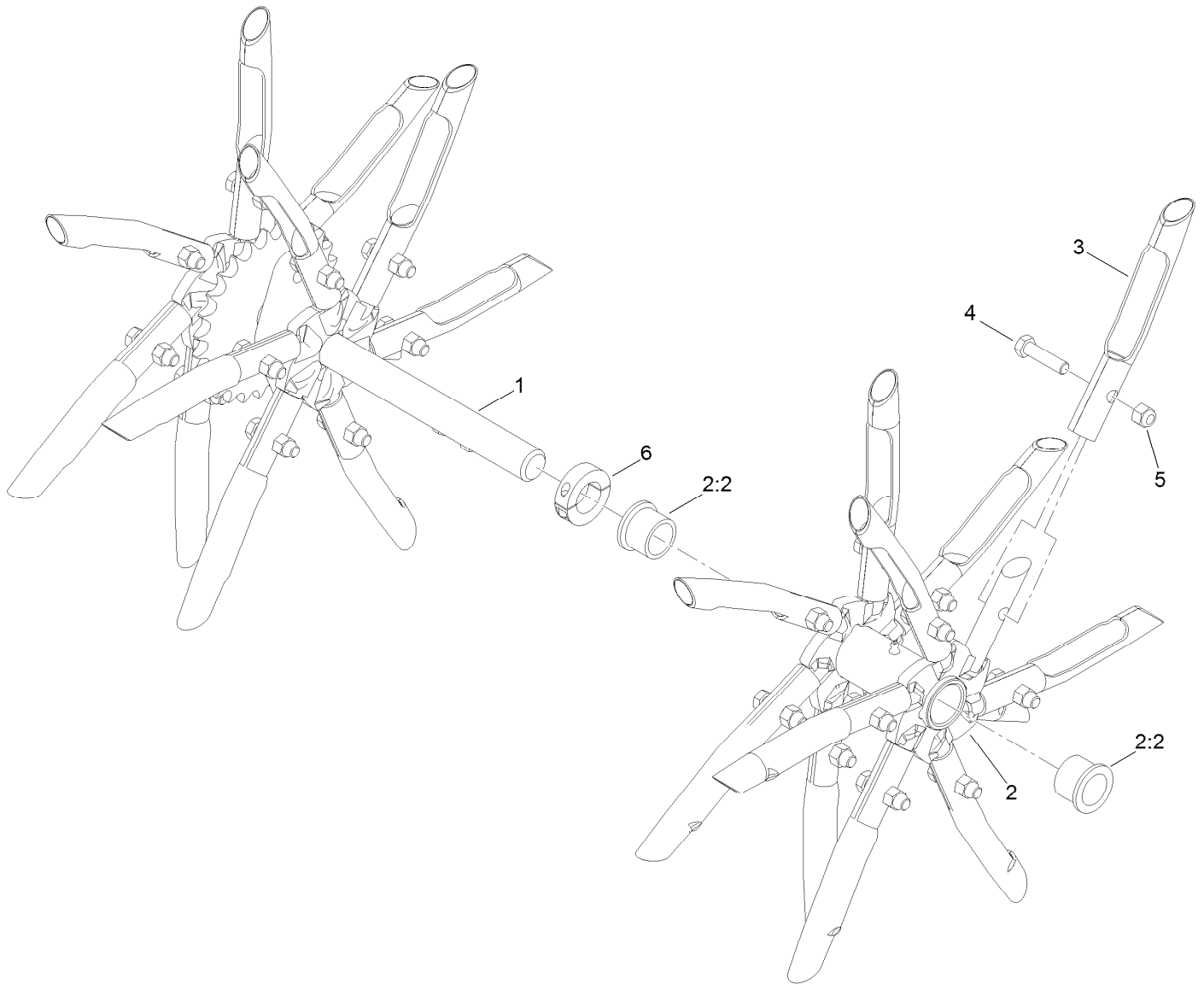

RH Tine Wheel Assembly No. 116-6738 (continued)

<i>Ref.</i>	<i>Part Number</i>	<i>Qty.</i>	<i>Description</i>	<i>Ref.</i>	<i>Part Number</i>	<i>Qty.</i>	<i>Description</i>
1	116-6727	1	Shaft-Tine, RH	4	323-8	24	Screw-HH
2	116-6731	1	Float Tine Shaft ASM	5	3296-39	24	Nut-Lock, NI
2:2	94-8949	2	Bushing-Flange	6	116-7271	1	Collar-Locking ●
3	126-2143	24	Tine-Coring (3/4 Inch)				

● Use Loctite® 243 on threads.

Electrical Assembly

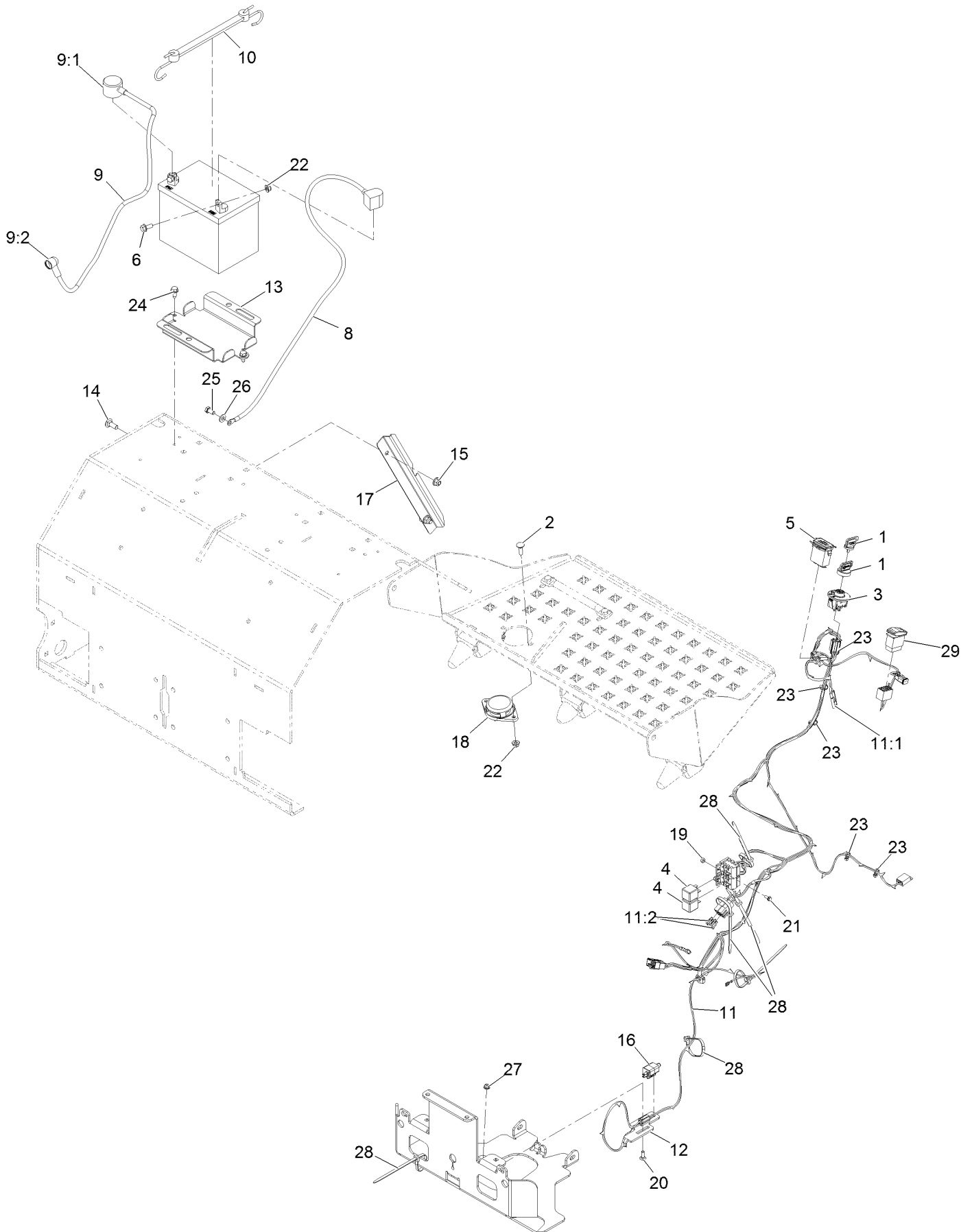

Electrical Assembly (continued)

<i>Ref.</i>	<i>Part Number</i>	<i>Qty.</i>	<i>Description</i>	<i>Ref.</i>	<i>Part Number</i>	<i>Qty.</i>	<i>Description</i>
1	1-603511	1	Key-Ignition	14	3231-2	2	Bolt-Carriage 3/8-16 X 1
1	103-2106	1	Key-Exmark Logo	15	104-8301	2	Nut-Nyloc 3/8-16 Flg
2	3230-2	2	Bolt-Carriage 5/16-18 X 1	16	110-6765	1	Switch
3	137-4100	1	Switch-Ignition	17	116-9394-03	1	Guard-Harness
4	1-643275	2	Relay-12Vdc 40 Amp	18	92-6282	1	Switch-Seat
5	1-513374	1	Meter-Engine Hours	19	3296-2	2	Nut-Nyloc #10-24
6	3234-5	2	Screw-HH Flg 5/16-18 X 3/4	20	3229-1	1	Bolt-Carriage 1/4-20 X 3/4
8	117-6422	1	Cable-Battery, Black	21	3290-321	2	Screw-HWH
9	109-7630	1	Positive Battery Cable ASM	22	104-8300	4	Nut-Nyloc 5/16-18 Flg
9:1	109-2407	1	Insulator-Battery	23	1-303287	5	Tie-Cable 5 1/2 (Small)
9:2	1-543393	1	Insulator-Solenoid	24	32144-70	2	Screw-HWH 5/16-18 X 3/4 Tf
10	104-2466	1	Holddown-Battery	25	33114-016	1	Screw-HH M8-1.25 X 16Mm
11	126-9480	1	Harness-Wire ●	26	33094-00	1	Washer
11:1	116-0053	1	Cap-Plug	27	104-7201	1	Nut-Nyloc 1/4-20 Flg
11:2	1-816001	2	Fuse-Blade Type, 20 Amp	28	1-303335	5	Tie-Cable 7 15/16 (Large)
12	116-7589	1	Mount-Switch	29	95-8999	1	Switch
13	116-9383-03	1	Bracket-Battery				

● Use dielectric grease on all unsealed connectors and terminals only. Do not apply in sealed connectors.

Notes:

Notes:

Notes:



MAXIMIZE THE PERFORMANCE OF YOUR EXMARK MACHINE.



EXMARK® PREMIUM ENGINE OIL

Exmark now offers a family of engine oil viscosities to perform well in any environment. Each viscosity has the same synthetic formulation to give you what you need in punishing conditions. We designed each grade to the highest quality, making it ideal even for diesel applications. Coupled with Exmark Premium Fuel Treatment, we have the performance products to make your machine hum.

EXMARK PREMIUM ENGINE OIL SAE 30/10W-30

- Meets zero shear requirements of a straight grade SAE 30 as well as the cold temp properties of a 10W-30.
- Most versatile oil in the industry.
- Superior corrosion protection over conventional oil - even in corrosive, humid environments.

EXMARK PREMIUM ENGINE OIL SAE 20W-50

- Perfect for your big block engine, or any application in severe service.
- Same full synthetic formulation as all other Exmark Premium viscosities.
- Also effective for use in severe service small block engines.

EXMARK PREMIUM ENGINE OIL SAE 10W-50

- Full synthetic formulation gives you peak performance. Don't settle for less.
- Wide span multi-grade combines easy starting in cold weather with maximum protection in high temperature operation.
- Reduce friction & wear over standard mineral formulations.

EXMARK PREMIUM ENGINE OIL SAE 0W-40

- The perfect choice for when the weather turns cold or unpredictable, and your Exmark UTV has to perform.
- Commercial quality for severe service.
- Advanced additive package helps prevent corrosion from long-term storage.

EXMARK PREMIUM ENGINE OIL UTV FORMULATION

- 4-cycle high-temp formulation.
- Heavier viscosity, full synthetic, perfect for your UTV.

EXMARK PREMIUM UTV EXTREME CONDITIONS GEAR OIL

- SAE 80W-90, designed to keep your UTV performing at its peak.
- Shear stable, hypoid gear lube.
- Includes a premium additive system to combat wear, oxidation, rust & corrosion.

Available from your local Exmark dealer. Find your closest dealer at exmark.com

EXMARK ACCESSORIES AND OPTIONS*

MID-MOUNT RIDING ACCESSORIES AND OPTIONS

CUSTOM RIDE SEAT SUSPENSION SYSTEM	OPERATOR CONTROLLED DISCHARGE
FULL SUSPENSION SEAT	SUN SHADE
DECK LIFT ASSIST KIT	TRASH CONTAINER
HITCH KIT	TURF STRIPER
LIGHT KIT	ULTRA VAC COLLECTION SYSTEM
12V POWER PORT	ULTRA VAC QUICK DISPOSAL SYSTEM
MICRO-MULCH SYSTEM	

OUT-FRONT RIDING ACCESSORIES AND OPTIONS

CUSTOM RIDE SEAT SUSPENSION SYSTEM	SNOW BLADE
DUAL-TAIL WHEEL	SNOWBLOWER
FLOOR PAN EXTENDER	SUN SHADE
HITCH KIT	TRASH CONTAINER
LIGHT KIT	ULTRA VAC COLLECTION SYSTEM
MICRO-MULCH SYSTEM	ULTRA VAC QUICK DISPOSAL SYSTEM
ROLL OVER PROTECTION SYSTEM (ROPS)	WEATHER CAB

WALK-BEHIND ACCESSORIES AND OPTIONS

GRASS CATCHER	TURF STRIPER
MICRO-MULCH SYSTEM	STANDON

*Some accessories and options not available for some models.

Place Model No. and Serial No.
Label Here (Included in the Literature
Pack) or Fill in Below

Model No. _____

Serial No. _____

Date Purchased _____

Engine Model No. and Spec. No. _____

Engine Serial No. (E/No) _____

© 2017 Exmark Mfg. Co., Inc.
Industrial Park Box 808
Beatrice, NE 68310
All Rights Reserved

Part No. 4503-523 Rev. A
(402) 223-6375
Fax (402) 223-5489
Printed in the USA.

