



TURF TRACER[®]

S-SERIES LP

Model No. TTS680PKC483E0—Serial No. 402082300 and Up

Picture below may not reflect actual product.

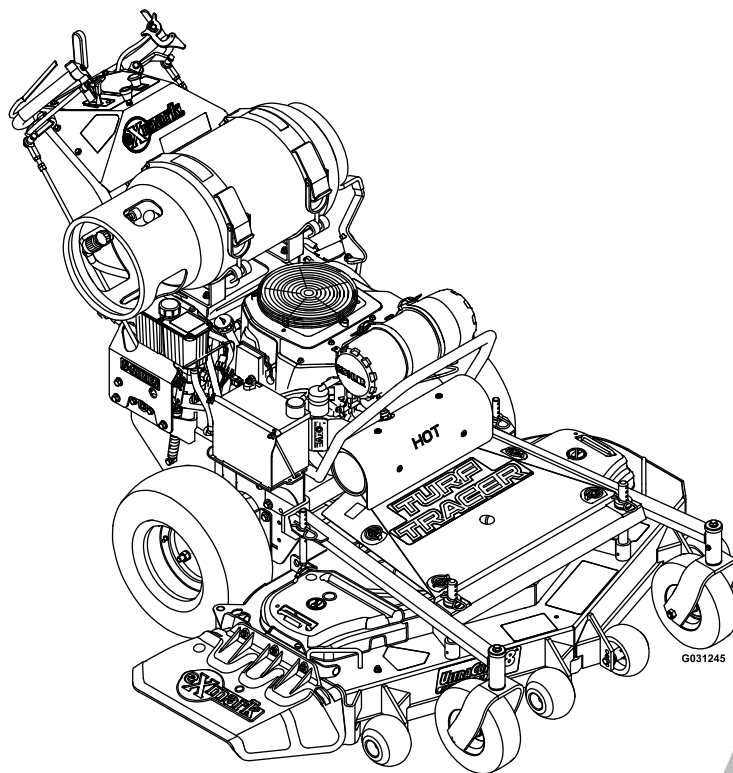

Parts Manual

Part No. 4503-474 Rev. A

Ordering Replacement Parts

To order replacement parts, please supply the part number, the quantity, and the description of each part desired.

Understanding Reference Numbers

Each identified part in an illustration has a reference number. The reference number for a part also appears in the parts list, along with other information about the part.

This catalog uses two special reference number formats, one to indicate parts in a service assembly and another to indicate the quantity of a given part in an illustration.

Service Assembly Reference Numbers

Parts in service assemblies have reference numbers in the form a:b. The a represents the reference number of the entire service assembly and the b represents a sequential number unique to each part within the service assembly.

For example, a wheel assembly might be identified by reference number 6, the tire by 6:1, the valve by 6:2, and the wheel by 6:3. When you order the assembly identified by reference number 6, you receive all parts identified by reference numbers 6:1, 6:2, and 6:3. However, you may also order any part individually. Reference numbers of this type appear in illustration and in parts lists.

Reference Numbers Indicating Quantity

In an illustration, if a reference number indicates more than one part, the reference number has the form nX y. The n represents the quantity of the part, the X is the multiplication symbol, and the y represents the reference number.

For example, in an illustration, the reference number 2X 37 means that two of the parts identified by reference number 37 are indicated.

Touch Up Paint

Exmark black touch up spray paint – gloss black.

Exmark red touch up paint (spray paint – P/N 1-850337 - .6 oz liquid bottle – P/N 103-9140).



If your Exmark dealer does not have the Exmark part in stock, Exmark will get the parts to the dealer the next business day or the part will be FREE Guaranteed!! (Some restrictions apply. See your participating Exmark Dealer for details.)

Contents

Complete Deck Assembly.....	4
Deck Assembly.....	6
Deck W/Decals Assembly No. 126-0781.....	8
Deck Idler Assembly No. 126-2314.....	10
Main Frame Assembly.....	12
Engine Deck.....	14
Handle Assembly.....	16
Controls Assembly.....	18
Fuel Assembly.....	20
Engine Assembly.....	22
Ground Drive Assembly.....	24
Pump Idler Assembly No. 126-0615.....	26
Electrical Assembly.....	28

Complete Deck Assembly

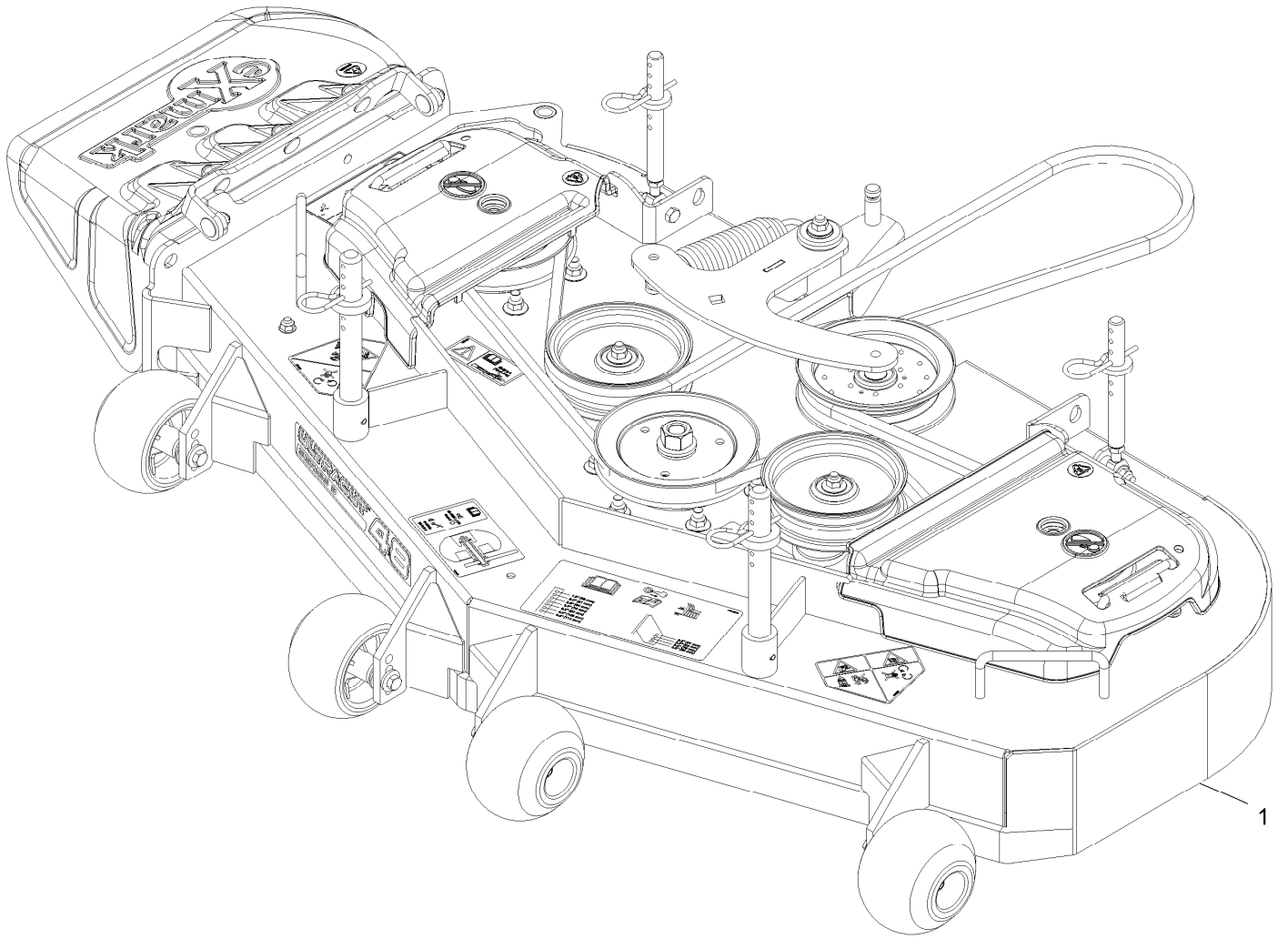

Complete Deck Assembly (continued)

<i>Ref.</i>	<i>Part Number</i>	<i>Qty.</i>	<i>Description</i>
1	126-1909	1	ASM-Complete Deck 48

Deck Assembly

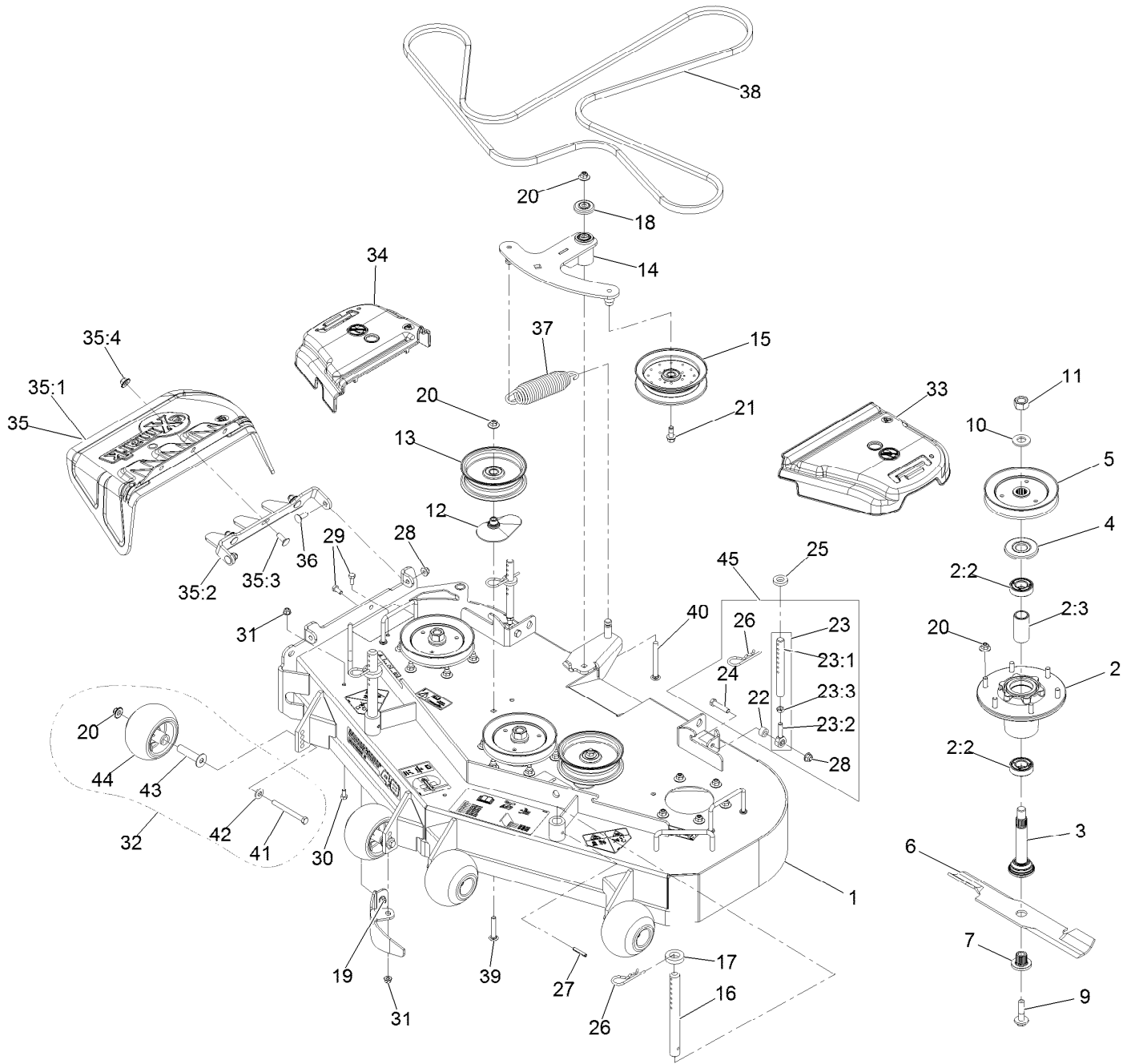

Deck Assembly (continued)

<i>Ref.</i>	<i>Part Number</i>	<i>Qty.</i>	<i>Description</i>	<i>Ref.</i>	<i>Part Number</i>	<i>Qty.</i>	<i>Description</i>
1	126-0781	1	ASM, Deck 48" W/Decals	23:1	1-413525	1	Link, Rear Deck Support
2	116-3344	3	ASM-Cutter Hsg With Bearings	23:2	1-613204	1	Balljoint
2:2	116-0720	2	Bearing-Ball	23:3	3220-3	1	Nut-HJ
2:3	116-3312	1	Spacer-Bearing	24	323-9	2	Screw-HH
3	116-3342	3	ASM-Spindle And Seal ◻	25	1-323539	2	Spacer
4	116-1286	3	Guard,Bearing Top .989	26	1-806009	4	Hairpin, .177
5	116-0674	3	Sheave,Blade Drive 5.90	27	1-806332	2	Roll Pin, 1/4 X 1-1/2
6	116-5177	3	Blade-Extreme 2, 16.25" ●	28	104-8301	4	Nut-HF, NI
6	103-6401	3	Blade-Notched	29	322-3	2	Screw-HH
6	103-6391	3	Blade, Mulching ◆	30	322-2	1	Screw-HH
6	103-6386	3	Blade, Low Lift ●	31	104-8300	3	Nut-HF, NI
6	103-6381	3	Blade, Solid ●	32	116-9981	4	Kit, Anti-Scalp Roller
7	103-3037	3	Bushing, Splined	33	109-6936	1	Cover-Belt, LH
9	109-9220	3	Screw,Sems (1/2-20 X 2.19, GR5) ■ ○	34	109-6935	1	Cover-Belt, RH
10	103-2802	3	Washer	35	126-0959	1	ASM, Discharge Chute
11	116-7306	3	Nut-Hex ▲	35:1	109-2738	1	Chute, Discharge
12	109-2872	2	Spacer-Pulley	35:2	126-0958-01	1	Bracket, Discharge Chute
13	116-4669	2	Idler-Pulley, Flat	35:3	3231-22	3	Screw-CARR
14	126-2314	1	ASM, Deck Idler	35:4	109-6658	3	Nut-Flange, NI
15	116-4668	1	Idler-Pulley, Flanged	36	3231-22	2	Screw-CARR
16	1-603001	2	Rod, Deck Support	37	116-6317	1	Spring-Extension
17	1-413425	2	Spacer-Deck Support	38	126-0783	1	Belt, Deck
18	103-2916	1	Guard-Top	39	3231-40	2	Bolt-CARR, Short Neck
19	126-2782-01	1	Baffle, Dogleg	40	3231-24	1	Screw-CARR
20	109-6658	25	Nut-Flange, NI	41	116-9362	4	Screw-HH
21	126-1680	1	Screw-Hfh	42	98-5975	4	Washer-Belleville
22	1-603050	2	Spacer	43	116-8131	4	Axle, Roller
23	1-414521	2	Link Assy	44	103-8415	4	Roller-Anti-Scalp
				45	1-411532	2	Kit, Support Link W/Pin

● Optional Equipment

▲ Torque to 130-160 ft-lb

◆ Requires installation of mulch kit for proper mulching. See your Exmark dealer for details.

◻ Apply Mobil HTS grease (P/N 103-5217 1.5 oz packet) (or a food-grade anti-seize). See operator s manual for locations.

○ Apply lubricant to threads as needed to prevent seizing. Copper based anti-seize preferable. Grease is an acceptable substitute.

■ Torque to 50-60 ft-lb

Deck W/Decals Assembly No. 126-0781

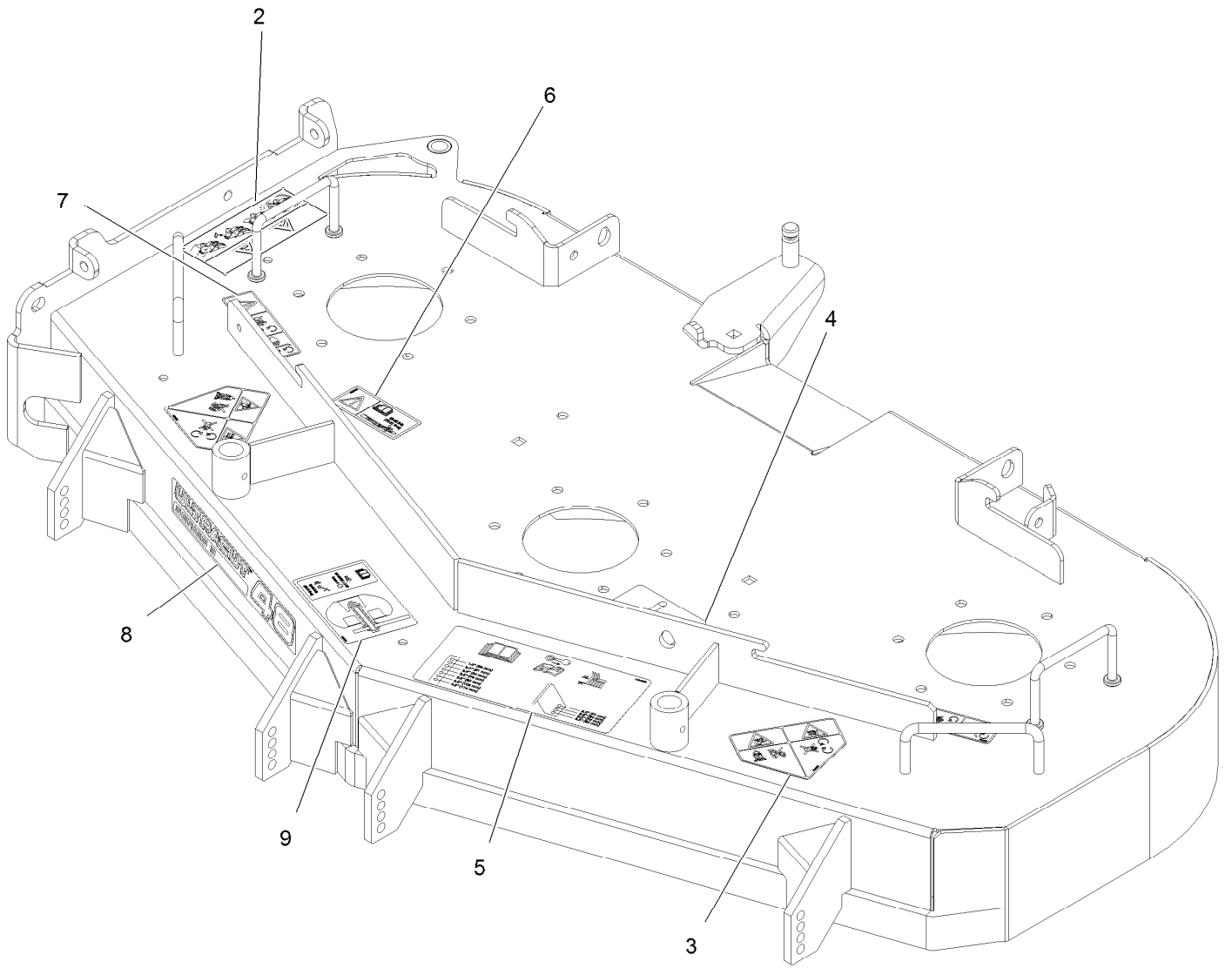

Deck W/Decals Assembly No. 126-0781 (continued)

<i>Ref.</i>	<i>Part Number</i>	<i>Qty.</i>	<i>Description</i>	<i>Ref.</i>	<i>Part Number</i>	<i>Qty.</i>	<i>Description</i>
2	114-3489	1	Decal-Warning, Bagger	6	116-8283	1	Decal-Bolt Torque
3	112-8760	2	Decal-Danger	7	112-9028	3	Decal-Cover, Missing
4	116-8727	1	Decal-Belt Routing	8	126-6746	1	Decal-Ultracut 48 Series 3
5	116-8278	1	Decal-Anti-Scalp	9	126-0898	1	Decal-Roller Mounting

Deck Idler Assembly No. 126-2314



Deck Idler Assembly No. 126-2314 (continued)

<i>Ref.</i>	<i>Part Number</i>	<i>Qty.</i>	<i>Description</i>	<i>Ref.</i>	<i>Part Number</i>	<i>Qty.</i>	<i>Description</i>
1		1	Weld, Idler Arm ●	5	103-5677	1	Spacer
2	106-7159	2	O-Ring	6	103-3505	1	Seal-Lip, Double
3	32120-10	2	Ring-Snap	7	103-3506	1	Seal-Lip, Single
4	103-3504	2	Bearing-Spherical	8	302-40	1	Fitting-Grease, 90 DEG

● Not serviced separately

Main Frame Assembly

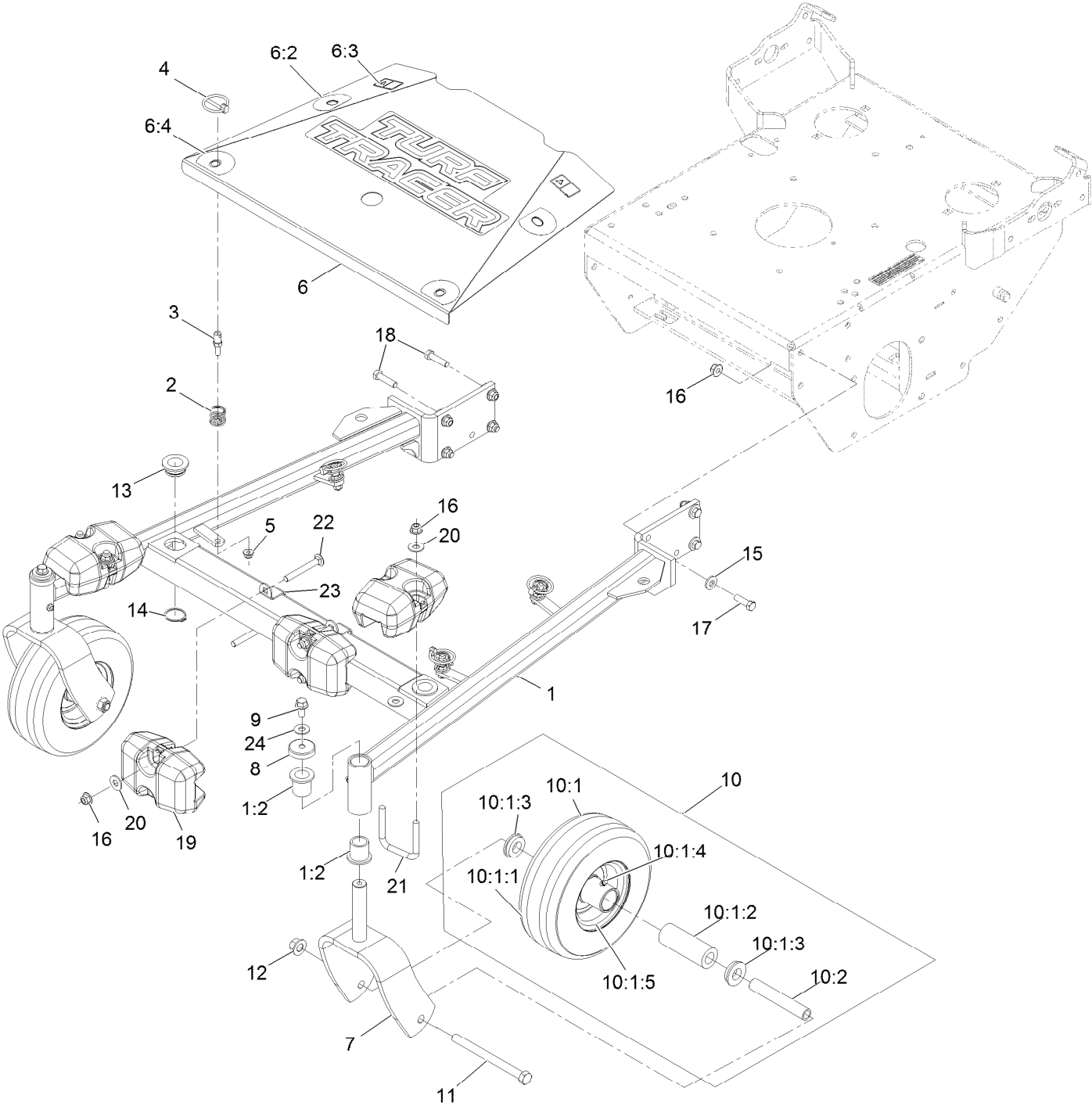

Main Frame Assembly (continued)

<i>Ref.</i>	<i>Part Number</i>	<i>Qty.</i>	<i>Description</i>	<i>Ref.</i>	<i>Part Number</i>	<i>Qty.</i>	<i>Description</i>
1	126-1514	1	ASM, Frame W/ Bushings, 48	10:1:2	1-513809	1	Bearing
1:2	1-303514	4	Bearing-Flanged	10:1:3	1-513810	2	Bushing-Flanged
2	126-1503	4	Spring	10:1:4	302-61	1	Zerk-45° 1/4-28
3	126-1504	4	Pin-Spring	10:1:5		1	Wheel ●
4	92-1298	4	Pin-Lynch	10:2	1-513547	1	Spacer
5	104-8300	4	Nut-Nyloc 5/16-18 Flg	11	325-20	2	Screw-HH 1/2-13 X 6
6	126-1517	1	ASM, Shield W/ Decals, 48	12	99-5107	2	Nut-Lock 1/2-13
6:2	126-6892	1	Decal-Turf Tracer	13	1-513336	2	Bushing-Deck
6:3	106-5517	2	Decal-Warning	14	32120-33	2	Ring-Retaining
6:4	126-1692	4	Decal-Scratch Cover	15	98-5975	8	Washer-Spring Disc 3/8
7	116-7941-01	2	Fork, Caster [red]	16	104-8301	16	Nut-Nyloc 3/8-16 Flg
8	126-1425	2	Cap, Dust	17	323-7	6	Screw-HH 3/8-16 X 1 1/4
9	110-1718	2	Screw-Hex Flange 3/8-16 X 3/4	18	323-8	2	Screw-HH 3/8-16 X 1 1/2
10	1-513547	2	Spacer	19	103-2455-01	4	Weight-Support, Caster
10	103-2171	2	Kit,Semi-Pneumatic Wheel Replacement	20	3256-4	8	Washer-Flat
10:1		1	Wheel And Tire ASM ●	21	103-2469	2	U-Bolt
10:1:1		1	Tire ●	22	3231-10	4	Screw-CARR
				23	126-3851-01	2	Strap, Weight
				24	1-373034	2	Washer

● Not serviced separately

Engine Deck

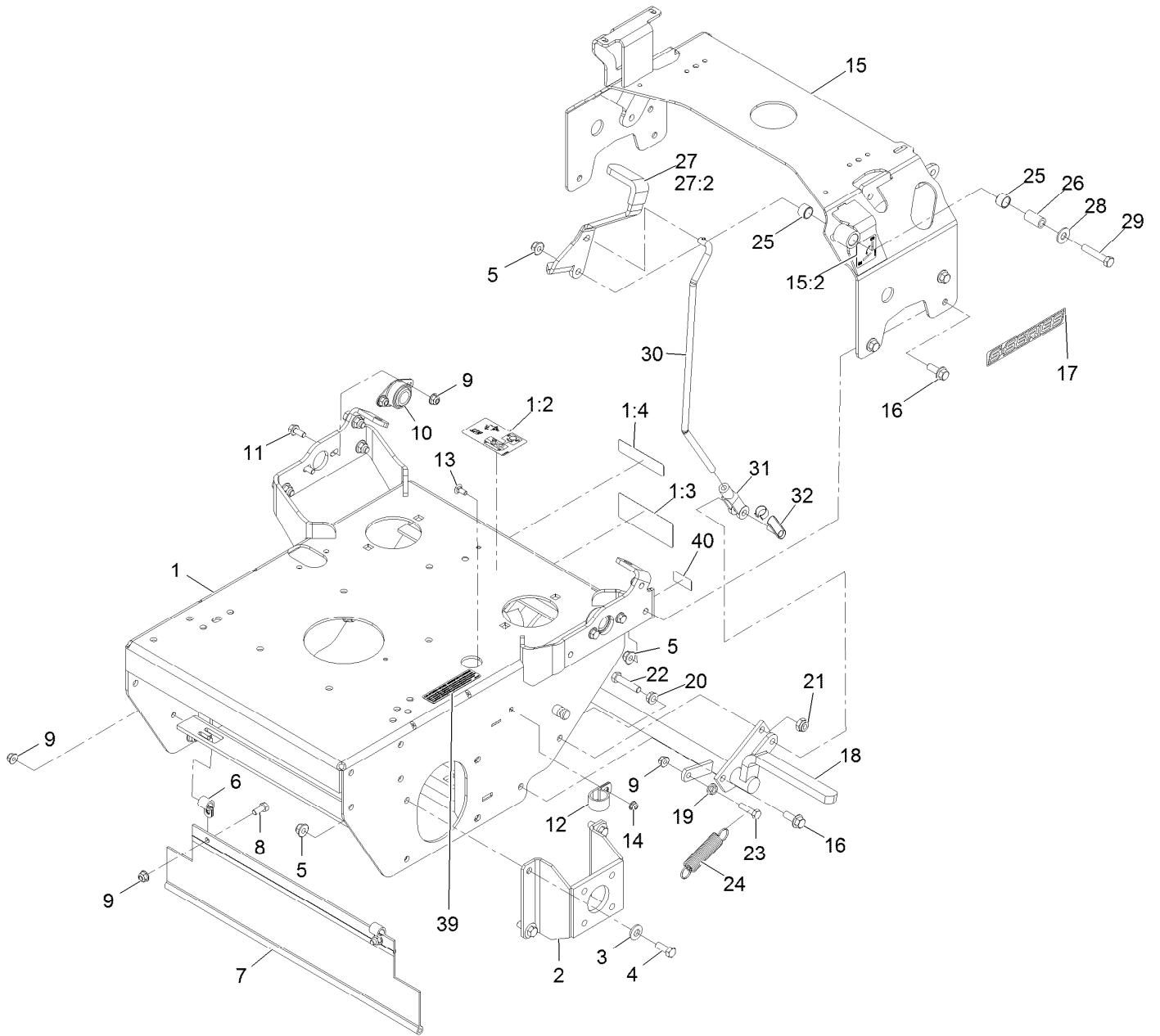

Engine Deck (continued)

<i>Ref.</i>	<i>Part Number</i>	<i>Qty.</i>	<i>Description</i>	<i>Ref.</i>	<i>Part Number</i>	<i>Qty.</i>	<i>Description</i>
1	126-1238	1	ASM, Engine Deck W/ Decals	16	3234-42	9	Screw HHF 3/8-16 X 1
1:2	116-8253	1	Decal-Drive Release	17	126-6572	2	Decal-S-Series
1:3	126-1400	1	Decal-Warning, Sulky	18	116-9964	1	Brake
1:4	98-1977	1	Decal-Warning	19	32128-20	1	Nut-Whizlock 5/16-18
2	1-412082-01	2	Mount-Wheel Motor	20	3290-357	1	Nut-Whizlock 3/8-16
3	98-5975	8	Washer-Spring Disc 3/8	21	3296-44	1	Nut-Lock, NI
4	323-6	8	Screw-HH 3/8-16 X 1	22	323-9	1	Screw-HH 3/8-16 X 1 3/4
5	104-8301	18	Nut-Nyloc 3/8-16 Flg	23	322-6	1	Screw-HH 5/16-18 X 1 1/4
6	1-413510	2	Clip-Loom	24	1-323161	1	Spring
7	103-2056	1	Shield-Drag	25	1-413347	2	Sleeve-Bushing
8	322-3	2	Screw-HH 5/16-18 X 3/4	26	1-413344	1	Bushing-Pivot
9	104-8300	7	Nut-Nyloc 5/16-18 Flg	27	126-2180	1	ASM, Brake Lever W/ Grip
10	1-633102	2	Bearing-Flanged	27:2	1-303020	1	Grip-Lever
11	3234-47	4	Screw-HH Flg 5/16-18 X 3/4	28	3256-4	1	Washer-3/8 Std
12	1-643312	1	Clip-Loom	29	323-10	1	Screw-HH 3/8-16 X 2
13	3229-11	1	Bolt-Carriage 1/4-20 X 5/8	30	116-9959	1	Linkage, Brake
14	104-7201	1	Nut-Nyloc 1/4-20 Flg	31	1-633131	1	Yoke-Linkage, Brake
15	126-2181	1	ASM, Tank Support W/ Decal	32	103-2399	1	Pin-Clevis Spring 3/8
15:2	116-5988	1	Decal-Park Brake, CE	39	117-2718	1	Decal-Arrester, Spark
				40	126-4345	1	Decal-Patent

Handle Assembly

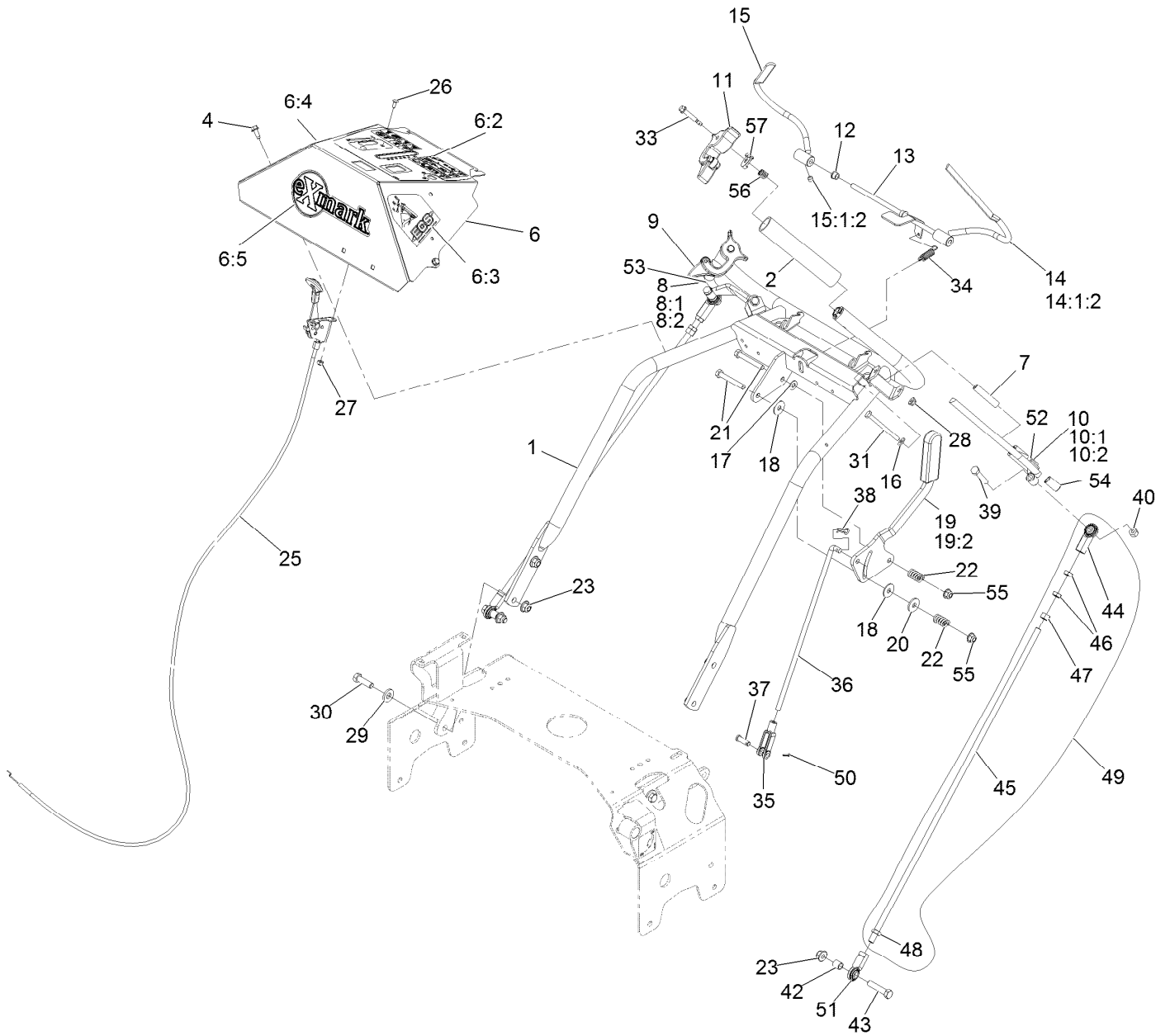

Handle Assembly (continued)

<i>Ref.</i>	<i>Part Number</i>	<i>Qty.</i>	<i>Description</i>	<i>Ref.</i>	<i>Part Number</i>	<i>Qty.</i>	<i>Description</i>
1	126-2642-03	1	Weld, Handle	25	109-3958	1	Control-Throttle
2	103-0815	2	Grip-Bar, Handle	26	1-807513	2	Bolt-Carriage #10-24 X 1/2
4	32144-10	2	Screw-HWH 1/4-20 X .62	27	3296-2	2	Nut-Nyloc #10-24
6	126-4705	1	ASM, Console W/ Decals	28	104-7201	2	Nut-Nyloc 1/4-20 Flg
6:2	135-2856	1	Decal-Console	29	98-5975	4	Washer-Spring Disc 3/8
6:3	103-2242	1	Decal, Ecs Instruction LH	30	323-7	4	Screw-HH 3/8-16 X 1 1/4
6:4	103-2243	1	Decal, Ecs Instruction RH	31	321-14	2	Screw-HH 1/4-20 X 2 3/4
6:5	126-6877	1	Decal, Exmark Logo	33	126-2931	2	Screw-Shoulder
7	103-0027	2	Bushing-Lever, Drive	34	1-303363	1	Spring-Extension
8	103-2513	1	Asm, Drive Lever RH	35	1-303105	1	Yoke-Adjustable
8:1	116-4082	1	Wld,RH Drive Lever	36	1-413225	1	Rod, Speed Control
8:2	126-9366	2	Bushing, Sleeve	37	1-808280	1	Pin-Clevis 5/16 X 1 49/64
9	103-1371	1	Thumb Latch Asm RH	38	1-806003	1	Hairpin-Cotter
10	103-2514	1	Asm, Drive Lever LH	39	322-9	2	Screw-HH 5/16-18 X 1 3/4
10:1	116-4081	1	Wld,LH Drive Lever	40	3296-29	2	Nut-Nyloc 5/16-18
10:2	126-9366	2	Bushing, Sleeve	42	103-1166	2	Spacer-Tube, Pump Link
11	103-1372	1	Thumb Latch Asm LH	43	323-9	2	Screw-HH 3/8-16 X 1 3/4
12	1-303365	2	Bushing-Nylon	44	103-2463	2	Balljoint
13	103-0769-03	1	Rod Weldment, OPC	45	103-1148	2	Rod,Drive Lever
14	116-4079	1	Wld,LH OPC Lever ■	46	3220-3	4	Nut-Jam 3/8-24
14:1:2	1-803322	1	Setscrew-5/16-24 X 5/16 ●	47	3219-3	2	Nut-Hex 3/8-24
15	116-4080	1	Wld,RH OPC Lever ■	48	3220-16	2	Nut-Jam 3/8-24 LH
15:1:2	1-803322	1	Setscrew-5/16-24 X 5/16 ●	49	116-3414	2	Drive Link ASM
16	3256-22	2	Washer-1/4 SAE	50	3272-5	1	Pin-Cotter 3/32 X 1/2
17	3256-23	1	Washer-5/16 SAE	51	103-1167	2	Joint-Ball End
18	1-323244	2	Washer-Friction	52	116-4081	1	Wld,LH Drive Lever
19	126-0148	1	Lever, Shift W/Grip	53	116-4082	1	Wld,RH Drive Lever
19:2	103-5994	1	Grip-Handle, Steering	54	126-9366	4	Bushing, Sleeve
20	1-603716	1	Washer-Friction Disc	55	104-8300	2	Nut-Nyloc 5/16-18 Flg
21	322-11	2	Screw-HH 5/16-18 X 2 1/4	56	1-633349	2	Spring-Compression
22	1-323245	2	Spring-Compression	57	126-2921	2	Latch, Ecs
23	104-8301	6	Nut-Nyloc 3/8-16 Flg				

● Use Pro-Lock, Nut Type (P/N 1-840022, .5ml tube) on threads.

■ Use Pro-Lock retaining type, Part no. 1-840023 (.5cc tube) on inside of bore of OPC hub.

Controls Assembly



Controls Assembly (continued)

<i>Ref.</i>	<i>Part Number</i>	<i>Qty.</i>	<i>Description</i>	<i>Ref.</i>	<i>Part Number</i>	<i>Qty.</i>	<i>Description</i>
1	116-9975	1	Weld, Motion Control, Rt	15	1-808280	2	Pin-Clevis 5/16 X 1 49/64
2	116-9974	1	Weld, Motion Control, Lt	16	1-806003	2	Hairpin-Cotter
3	1-803022	2	Setscrew-5/16-18 X 5/8	17	1-613089	2	Tab-Spring, Extension
4	126-2982-01	1	Weld, Speed Control	18	1-603693	2	Spring
5	1-603735	2	Bushing-Flanged	19	126-0610	2	Pin, Motion Control
6	103-0265	2	Spring, Neutral Return	20	1-603676	2	Swivel-Adjustable, Short
7	1-603737	2	Bolt-Neutral Return	21	1-413350	2	Link-Control, Speed
8	3256-23	9	Washer-5/16 SAE	22	3272-5	2	Pin-Cotter 3/32 X 1/2
9	3219-2	7	Nut-Hex 5/16-24	23	1-323245	1	Spring-Compression
10	3220-2	2	Nut-Jam 5/16-24	24	1-603903	1	Spacer
11	104-8300	6	Nut-Nyloc 5/16-18 Flg	25	103-3060	1	Knob-Tracking
12	32128-20	2	Nut-Whizlock 5/16-18	27	1-809056	2	Screw-Sh 5/16-18 X 1 3/8
13	322-5	2	Screw-HH 5/16-18 X 1	28	116-7918	1	Decal-Tracking Adjustment
14	1-303105	2	Yoke-Adjustable	29	302-19	2	Zerk-1/4-28 Str

Fuel Assembly

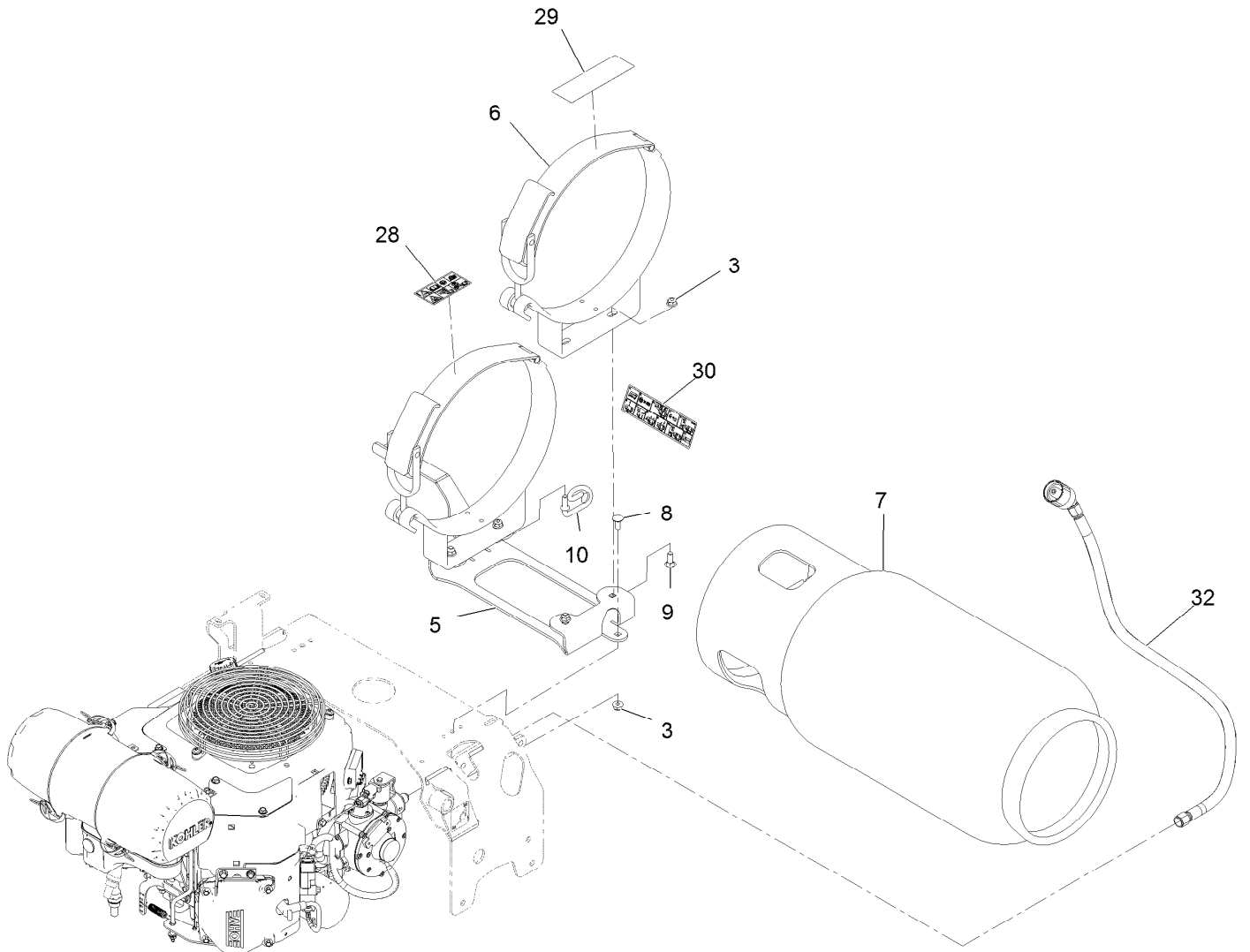

Fuel Assembly (continued)

<i>Ref.</i>	<i>Part Number</i>	<i>Qty.</i>	<i>Description</i>	<i>Ref.</i>	<i>Part Number</i>	<i>Qty.</i>	<i>Description</i>
3	104-8300	6	Nut-Nyloc 5/16-18 Flg	9	3230-16	3	Bolt-Carriage 5/16-18 X 7/8
5	126-1491-03	1	Weld, Tank Mount	10	126-1921	1	Retainer, LP Hose
6	116-1074	1	Brackets, LPG Tank - Horizontal (Pair)	28	126-3275	1	Decal-LPG Warning
7	126-4506	1	Tank, LP - 33.5 Lb.Horizontal-Al	29	126-3276	1	Decal-LPG Horiz Tank Spec
8	3230-23	2	Bolt-Carriage 5/16-18 X 3/4 Short Neck	30	126-3277	1	Decal-LPG Fuel Tank Replacement
				32	126-8403	1	ASM, LPG Hose W/Connector-Tt

Engine Assembly

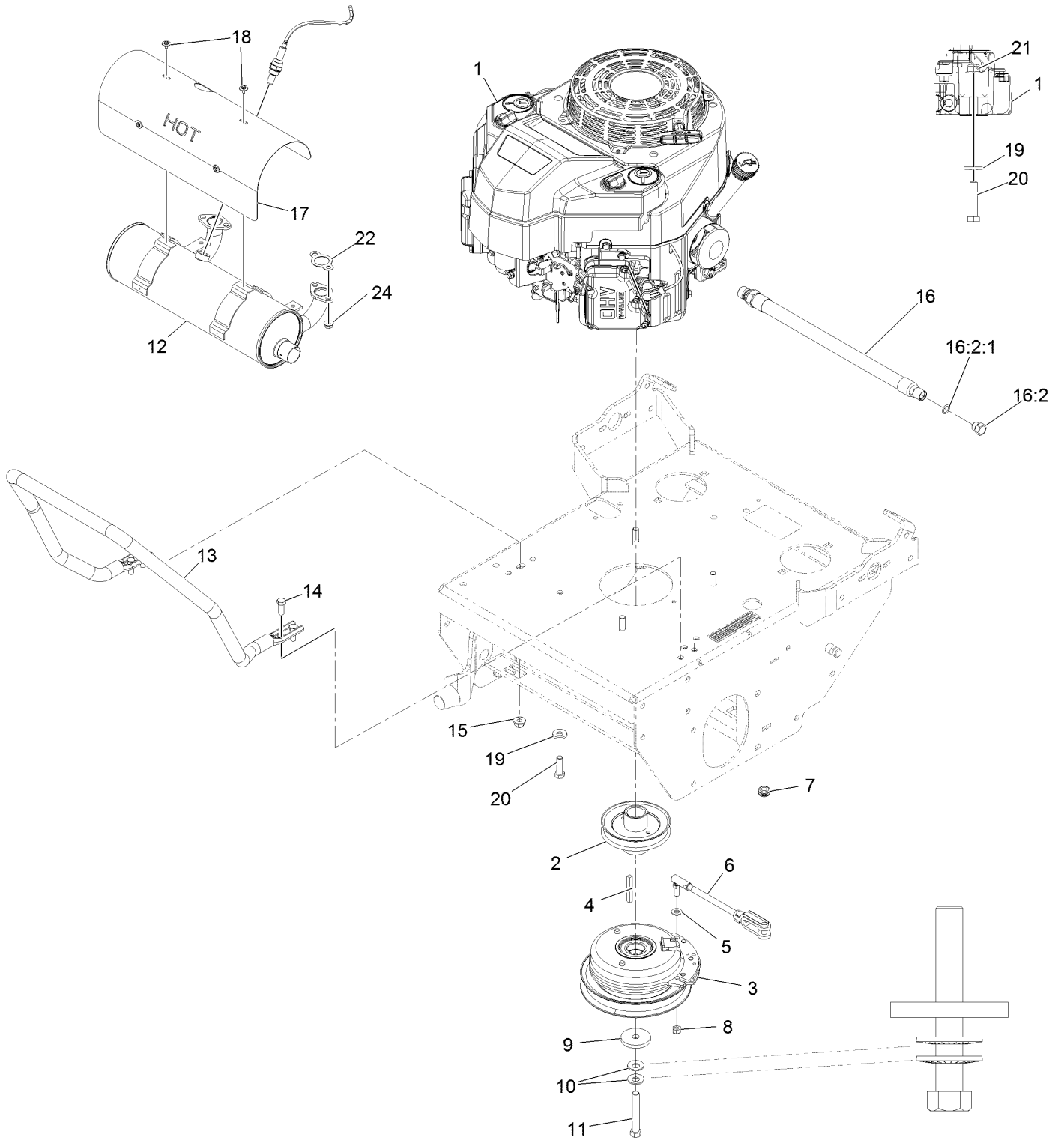

Engine Assembly (continued)

<i>Ref.</i>	<i>Part Number</i>	<i>Qty.</i>	<i>Description</i>	<i>Ref.</i>	<i>Part Number</i>	<i>Qty.</i>	<i>Description</i>
1		1	Engine, Kohler Pcv680 ■▲	14	323-6	4	Screw-HH 3/8-16 X 1
2	116-7328	1	Sheave, W/ Hub	15	104-8301	4	Nut-Nyloc 3/8-16 Flg
3	126-2616	1	Clutch, 125 Ft/Lbs, 1.13	16	116-5316	1	Oil Drain Hose ASM ♦
4	5-1336	1	Key-Machine 1/4 X 1/4 X 2 ○	16:2	353-508	1	Plug-W/O-Ring ●
5	3256-23	1	Washer-5/16 SAE	16:2:1	237-42	1	O-Ring
6	126-0620	1	ASM, Clutch Anchor	17	116-8654	1	Shield-Muffler, Ttx Efi
7	237-136	1	Grommet	18	116-1103	4	Screw-HH, Thread Forming
8	3296-4	1	Nut-Lock 5/16-24	19	1-303334	4	Washer-Spring Disc 5/16
9	109-6919	1	Washer-Clutch	20	322-7	4	Screw-HH 5/16-18 X 1 1/2
10	1-603610	2	Washer-Spring Disc 7/16	21	104-8300	4	Nut-Nyloc 5/16-18 Flg
11	3212-12	1	Screw-HH 7/16-20 X 3 □	22	110-6697	2	Gasket-Exhaust
12	116-8653	1	Muffler-Ttx, Efi	24	68-9400	4	Nut-Flange
13	116-8575-03	1	Guard,Air Cleaner				

● Torque to 24-26 ft-lb

▲ Obtain parts from www.kohlerplus.com

◆ Use a Teflon Pipe Sealant or equivalent on threads.

□ Use Pro-Lock, Nut Type (P/N 1-840022, .5ml tube) on threads.

○ Apply anti-seize compound to engine crankshaft, pulley hub I.D., clutch bore I.D. and square key.

■ Not serviced separately

Ground Drive Assembly

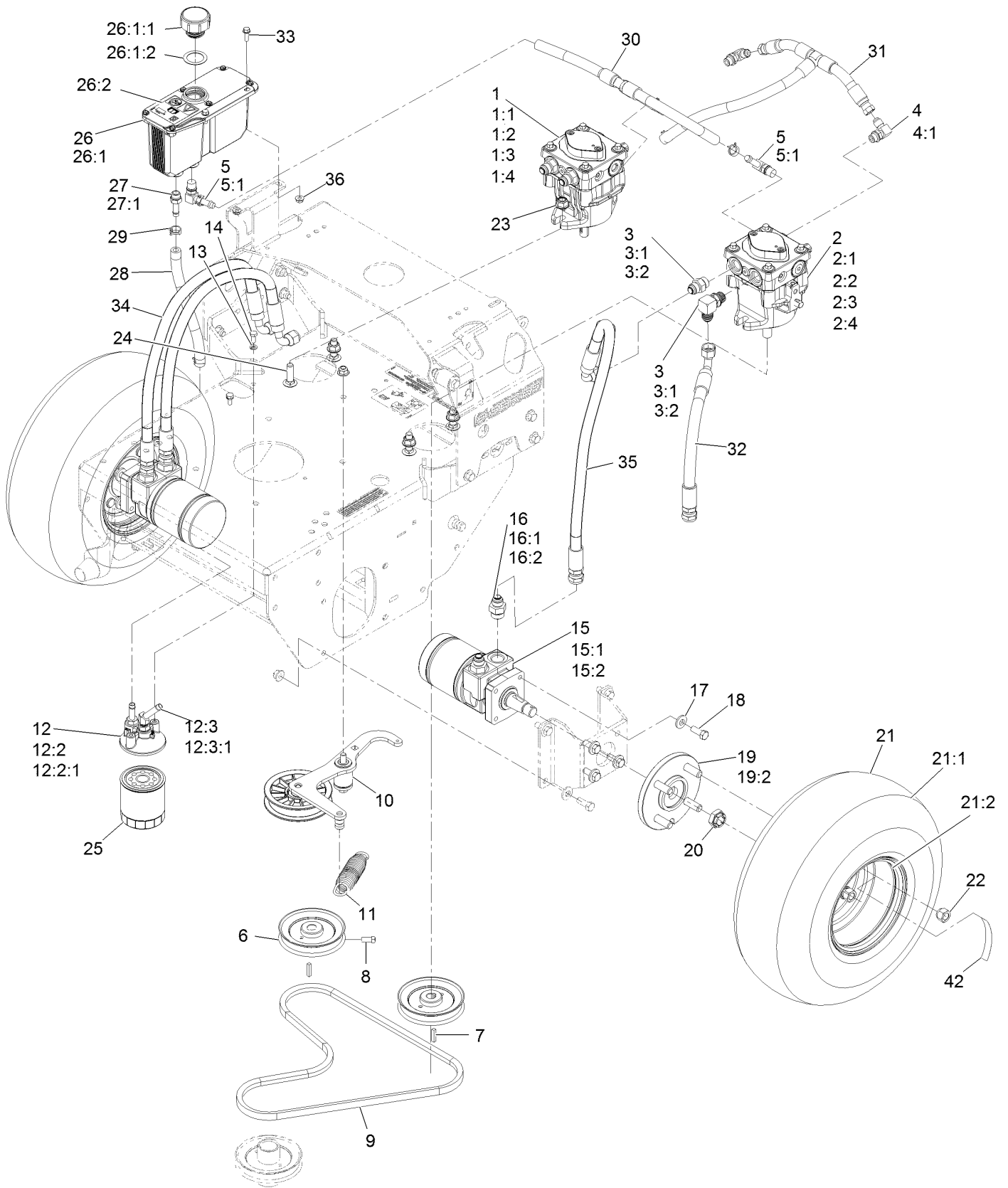

Ground Drive Assembly (continued)

<i>Ref.</i>	<i>Part Number</i>	<i>Qty.</i>	<i>Description</i>	<i>Ref.</i>	<i>Part Number</i>	<i>Qty.</i>	<i>Description</i>
1	116-0943	1	RH HYD Pump ASM	15:2	1-000138	1	Bearing And Seal Kit
1:1	103-2664	1	Input Shaft Kit	16	1-603991	4	Adapter-Straight
1:2	94-6922	1	Bearing-Thrust	16:1	237-80	1	O-Ring
1:3	103-2666	1	Cylinder Block Kit	16:2	1-603992	1	O-Ring-37 Flare #8
1:4	105-6184	1	Seal Overhaul Kit	17	98-5975	8	Washer-Spring Disc 3/8
2	116-0942	1	LH HYD Pump ASM	18	323-6	8	Screw-HH 3/8-16 X 1
2:1	103-2664	1	Input Shaft Kit	19	112-9049	2	Wheel Hub ASM
2:2	94-6922	1	Bearing-Thrust	19:2	1-633926	4	Stud-Wheel
2:3	103-2666	1	Cylinder Block Kit	20	116-2839	2	Nut-Lock
2:4	105-6184	1	Seal Overhaul Kit	21	1-613263	2	Wheel And Tire ASM
3	1-603990	3	Adapter-Straight	21:1	1-613264	1	Tire-Turfmaster
3	103-2153	1	Elbow-90°	21:2	1-603715	1	Rim-Wheel
3:1	1-603920	1	O-Ring-SAE #8	22	242-50	8	Nut-Lug 1/2-20
3:1	1-603920	1	O-Ring-SAE #8	23	114-8417	4	Nut-HF, NI
3:2	1-603992	1	O-Ring-37 Flare #8	24	3232-3	4	Bolt-Carriage 7/16-14 X 1 1/2
3:2	1-603992	1	O-Ring-37 Flare #8	25	109-4180	1	Element, Oil Filter
4	103-1802	2	Fitting-Elbow, 90 DEG	26	126-1248	1	ASM, HYD Reservoir ■
4:1	237-42	1	O-Ring	26:1		1	Reservoir-HYD ●
5	100-4887	3	Fitting-Elbow, 90	26:1:1	103-1948	1	Cap-Reservoir, HYD
5:1	237-42	1	O-Ring	26:1:2	103-1949	1	Gasket-Cap
6	1-413010	2	Sheave ASM	26:2	115-4212	1	Decal-Warning
7	1-807272	2	Key-5Mm X 5Mm X 25Mm	27	103-1912	1	Adapter-Straight
8	120-6474	4	Screw-Set, SQH 5/16-18 X 3/4	27:1	237-42	1	O-Ring
9	103-4761	1	Belt	28	103-2959	1	Hose-Charge
10	126-0615	1	ASM, Pump Idler	29	103-1988	6	Clamp-Hose 11/16
11	116-6316	1	Spring-Extension	30	126-0623	1	Hose-Case Drain
12	126-0621	1	ASM, Filter Head	31	126-0622	1	Hose-Charge
12:2	103-1912	1	Adapter-Straight	32	126-0856	1	ASM, HP Hose
12:2:1	237-42	1	O-Ring	33	32105-15	2	Screw-Machine 1/4-20 X 3/4
12:3	103-1807	1	Fitting-Barbed, 45 DEG	34	119-7827	2	HYD Hose ASM
12:3:1	237-42	1	O-Ring	35	119-7826	1	HYD Hose ASM
13	1-805004	2	Washer-Lock 1/4 Heavy	36	32128-33	2	Nut-Whizlock 1/4-20
14	321-3	2	Screw-HH 1/4-20 X 5/8	42	126-2056	2	Decal-Torque Wheel Lug-Hub
15	1-603718	2	HYD Motor ASM				
15:1	1-000119	1	Seal Kit				

● Not serviced separately

■ Use Exmark Premium Hydro Oil P/N 109-9828 (32oz)

Pump Idler Assembly No. 126-0615

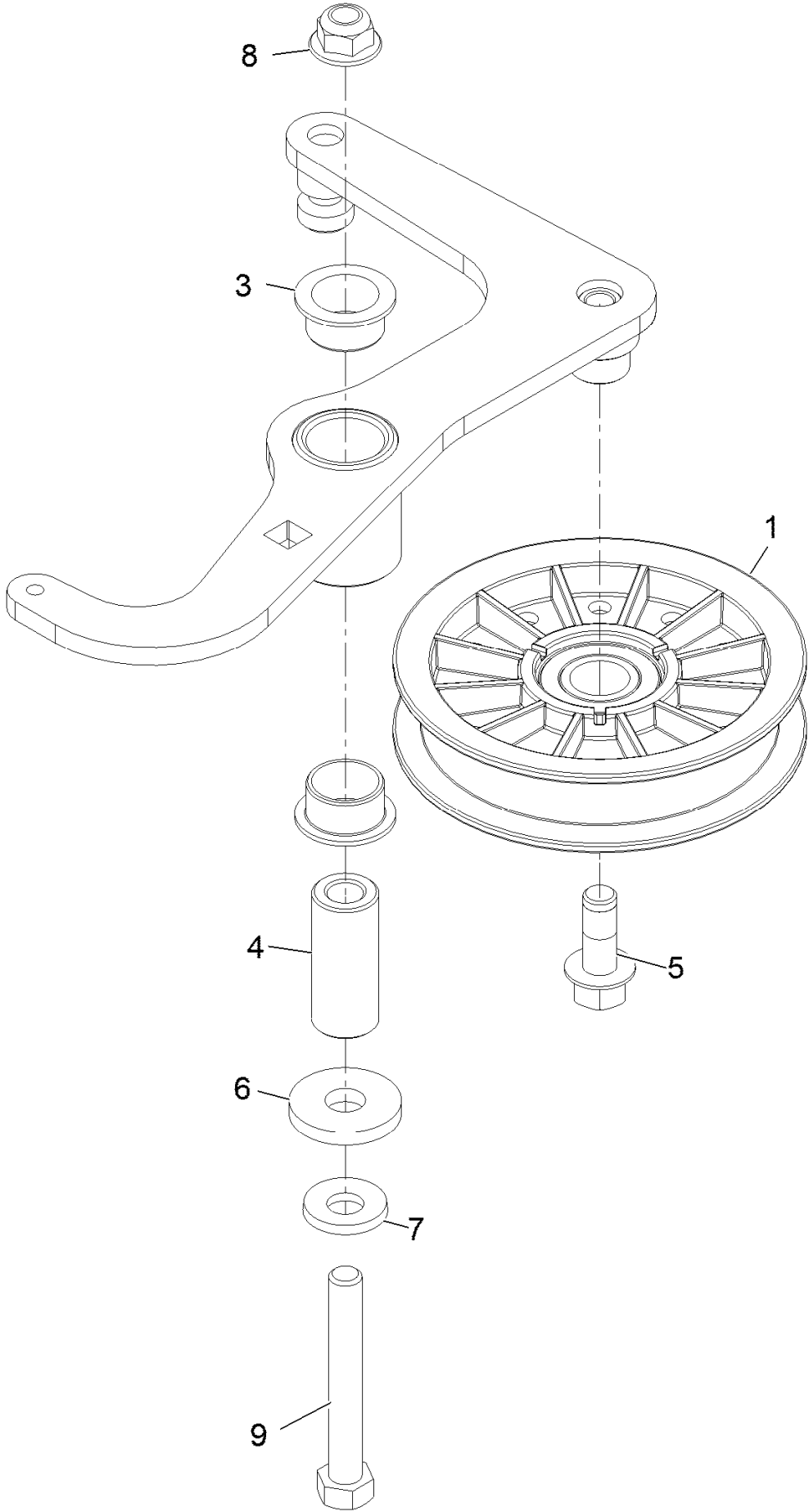

Pump Idler Assembly No. 126-0615 (continued)

<i>Ref.</i>	<i>Part Number</i>	<i>Qty.</i>	<i>Description</i>	<i>Ref.</i>	<i>Part Number</i>	<i>Qty.</i>	<i>Description</i>
1	109-4077	1	Pulley-Idler, Flat	6	1-373034	1	Washer
3	109-8054	2	Bushing-Flanged	7	98-5975	1	Washer-Spring Disc 3/8
4	116-8718	1	Spacer, Pivot	8	104-8301	1	Nut-Nyloc 3/8-16 Flg
5	126-1680	1	Screw-Hfh	9	112-7451	1	Screw-TAP

Electrical Assembly

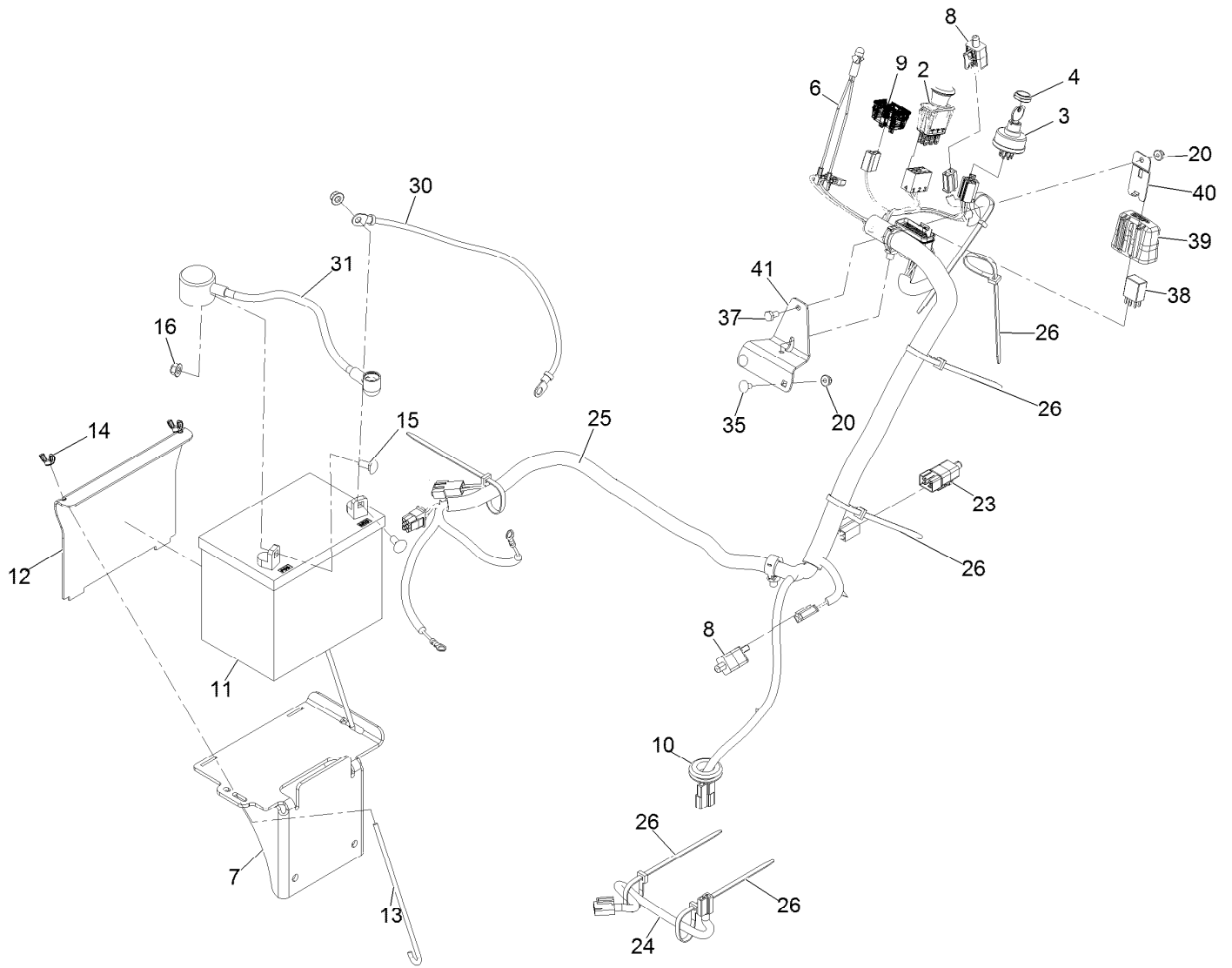

Electrical Assembly (continued)

<i>Ref.</i>	<i>Part Number</i>	<i>Qty.</i>	<i>Description</i>	<i>Ref.</i>	<i>Part Number</i>	<i>Qty.</i>	<i>Description</i>
2	103-5221	1	Switch-PTO	20	104-7201	3	Nut-Nyloc 1/4-20 Flg
3	135-2253	1	Switch, Key Start	23	126-1904	1	Switch, 2 Pole
4	103-0498	1	Nut-Ignition	24	126-0624	1	Harness-Clutch Pigtail
6	1-643267	1	Indicator-Red LED	25	126-6614	1	Harness-Wiring ▲
7	126-1470-03	1	Weld, Battery Mount	26	1-303335	7	Tie-Cable 7 15/16 (Large)
8	110-6765	2	Switch	30	1-413540	1	Cable-Battery, Negative ●
9	126-3931	1	Hour Meter	31	109-7628	1	Cable, Battery +
10	1-543286	1	Grommet	35	3229-10	2	Bolt-Carriage 1/4-20 X 1/2
11		1	Battery (300 CCA, Wet) ■	37	321-2	1	Screw-HH 1/4-20 X 1/2
12	126-0069-03	1	Bracket, Battery Hold Down	38	126-6157	1	Relay-Micro 280, Spdt
13	1-633651	2	Bolt-Holddown	39	32180-176	1	Cover-Block, Fuse
14	1-543792	2	Wingnut-Nyloc 1/4-20	40	32180-177	1	Clip-Mounting
15	3230-1	2	Bolt-Carriage 5/16-18 X 3/4	41	126-6603-03	1	Bracket-Mounting, Fuseblock
16	104-8300	2	Nut-Nyloc 5/16-18 Flg				

● Not illustrated

■ Not serviced separately

▲ Use dielectric grease on all unsealed connectors and terminals only. Do not apply in sealed connectors.

Notes:



MAXIMIZE THE PERFORMANCE OF YOUR EXMARK MACHINE.



EXMARK® PREMIUM ENGINE OIL

Exmark now offers a family of engine oil viscosities to perform well in any environment. Each viscosity has the same synthetic formulation to give you what you need in punishing conditions. We designed each grade to the highest quality, making it ideal even for diesel applications. Coupled with Exmark Premium Fuel Treatment, we have the performance products to make your machine hum.

EXMARK PREMIUM ENGINE OIL SAE 30/10W-30

- Meets zero shear requirements of a straight grade SAE 30 as well as the cold temp properties of a 10W-30.
- Most versatile oil in the industry.
- Superior corrosion protection over conventional oil - even in corrosive, humid environments.

EXMARK PREMIUM ENGINE OIL SAE 20W-50

- Perfect for your big block engine, or any application in severe service.
- Same full synthetic formulation as all other Exmark Premium viscosities.
- Also effective for use in severe service small block engines.

EXMARK PREMIUM ENGINE OIL SAE 10W-50

- Full synthetic formulation gives you peak performance. Don't settle for less.
- Wide span multi-grade combines easy starting in cold weather with maximum protection in high temperature operation.
- Reduce friction & wear over standard mineral formulations.

EXMARK PREMIUM ENGINE OIL SAE 0W-40

- The perfect choice for when the weather turns cold or unpredictable, and your Exmark UTV has to perform.
- Commercial quality for severe service.
- Advanced additive package helps prevent corrosion from long-term storage.

EXMARK PREMIUM ENGINE OIL UTV FORMULATION

- 4-cycle high-temp formulation.
- Heavier viscosity, full synthetic, perfect for your UTV.

EXMARK PREMIUM UTV EXTREME CONDITIONS GEAR OIL

- SAE 80W-90, designed to keep your UTV performing at its peak.
- Shear stable, hypoid gear lube.
- Includes a premium additive system to combat wear, oxidation, rust & corrosion.

Available from your local Exmark dealer. Find your closest dealer at exmark.com

EXMARK ACCESSORIES AND OPTIONS*

MID-MOUNT RIDING ACCESSORIES AND OPTIONS

CUSTOM RIDE SEAT SUSPENSION SYSTEM	OPERATOR CONTROLLED DISCHARGE
FULL SUSPENSION SEAT	SUN SHADE
DECK LIFT ASSIST KIT	TRASH CONTAINER
HITCH KIT	TURF STRIPER
LIGHT KIT	ULTRA VAC COLLECTION SYSTEM
12V POWER PORT	ULTRA VAC QUICK DISPOSAL SYSTEM
MICRO-MULCH SYSTEM	

OUT-FRONT RIDING ACCESSORIES AND OPTIONS

CUSTOM RIDE SEAT SUSPENSION SYSTEM	SNOW BLADE
DUAL-TAIL WHEEL	SNOWBLOWER
FLOOR PAN EXTENDER	SUN SHADE
HITCH KIT	TRASH CONTAINER
LIGHT KIT	ULTRA VAC COLLECTION SYSTEM
MICRO-MULCH SYSTEM	ULTRA VAC QUICK DISPOSAL SYSTEM
ROLL OVER PROTECTION SYSTEM (ROPS)	WEATHER CAB

WALK-BEHIND ACCESSORIES AND OPTIONS

GRASS CATCHER	TURF STRIPER
MICRO-MULCH SYSTEM	STANDON

*Some accessories and options not available for some models.

Place Model No. and Serial No.
Label Here (Included in the Literature
Pack) or Fill in Below

Model No. _____

Serial No. _____

Date Purchased _____

Engine Model No. and Spec. No. _____

Engine Serial No. (E/No) _____

© 2018 Exmark Mfg. Co., Inc.
2101 Ashland Ave
Beatrice, NE 68310
All Rights Reserved

Part No. 4503-474 Rev. A
(402) 223-6375
Fax (402) 223-5489
Printed in the USA.

