

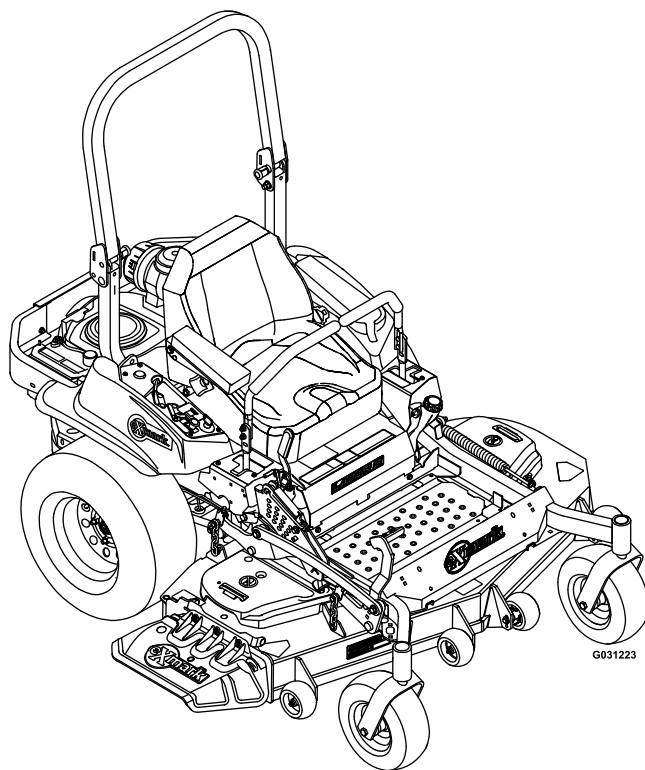

LAZER Z[®] X-SERIES

Model No. LZX801CKA60600—Serial No. 40000000 and Up

Picture below may not reflect actual product.



Parts Manual

Part No. 4503-348 Rev. A

Ordering Replacement Parts

To order replacement parts, please supply the part number, the quantity, and the description of each part desired.

Understanding Reference Numbers

Each identified part in an illustration has a reference number. The reference number for a part also appears in the parts list, along with other information about the part.

This catalog uses two special reference number formats, one to indicate parts in a service assembly and another to indicate the quantity of a given part in an illustration.

Service Assembly Reference Numbers

Parts in service assemblies have reference numbers in the form a:b. The a represents the reference number of the entire service assembly and the b represents a sequential number unique to each part within the service assembly.

For example, a wheel assembly might be identified by reference number 6, the tire by 6:1, the valve by 6:2, and the wheel by 6:3. When you order the assembly identified by reference number 6, you receive all parts identified by reference numbers 6:1, 6:2, and 6:3. However, you may also order any part individually. Reference numbers of this type appear in illustration and in parts lists.

Reference Numbers Indicating Quantity

In an illustration, if a reference number indicates more than one part, the reference number has the form nX y. The n represents the quantity of the part, the X is the multiplication symbol, and the y represents the reference number.

For example, in an illustration, the reference number 2X 37 means that two of the parts identified by reference number 37 are indicated.

Touch Up Paint

Exmark black touch up spray paint – gloss black.

Exmark red touch up paint (spray paint – P/N 1-850337 - .6 oz liquid bottle – P/N 103-9140).



If your Exmark dealer does not have the Exmark part in stock, Exmark will get the parts to the dealer the next business day or the part will be FREE Guaranteed!! (Some restrictions apply. See your participating Exmark Dealer for details.)

Contents

Complete Deck Assembly	4
Deck Assembly	6
Deck W/Decals Assembly No. 116-4232	8
Idler Assembly	10
Cutter Housing Assembly No. 103-9539	12
Main Frame Assembly	14
X-Series Decal	16
Roll-Over Protection System	18
Roll-Over Protection System Assembly No. 116-0230	20
Front Caster and Fork Assembly	22
Caster Wheel and Fork Assembly	24
Deck Lift Assembly	26
Height-of-Cut Assembly No. 109-7438	28
Controls Assembly	30
Motion Control Assembly	32
Rear Wheel Assembly	34
Park Brake Assembly	36
Seat Assembly	38
Seat Assembly (cont.)	40
Fuel Assembly	42
Fuel Tank Assembly	44
Engine Assembly	46
Hydraulic Assembly	48
LH Hydro Assembly No. 126-1325	50
RH Hydro Assembly No. 126-1326	52
Pump Idler Assembly No. 116-1255	54
Electrical Assembly	56

Complete Deck Assembly

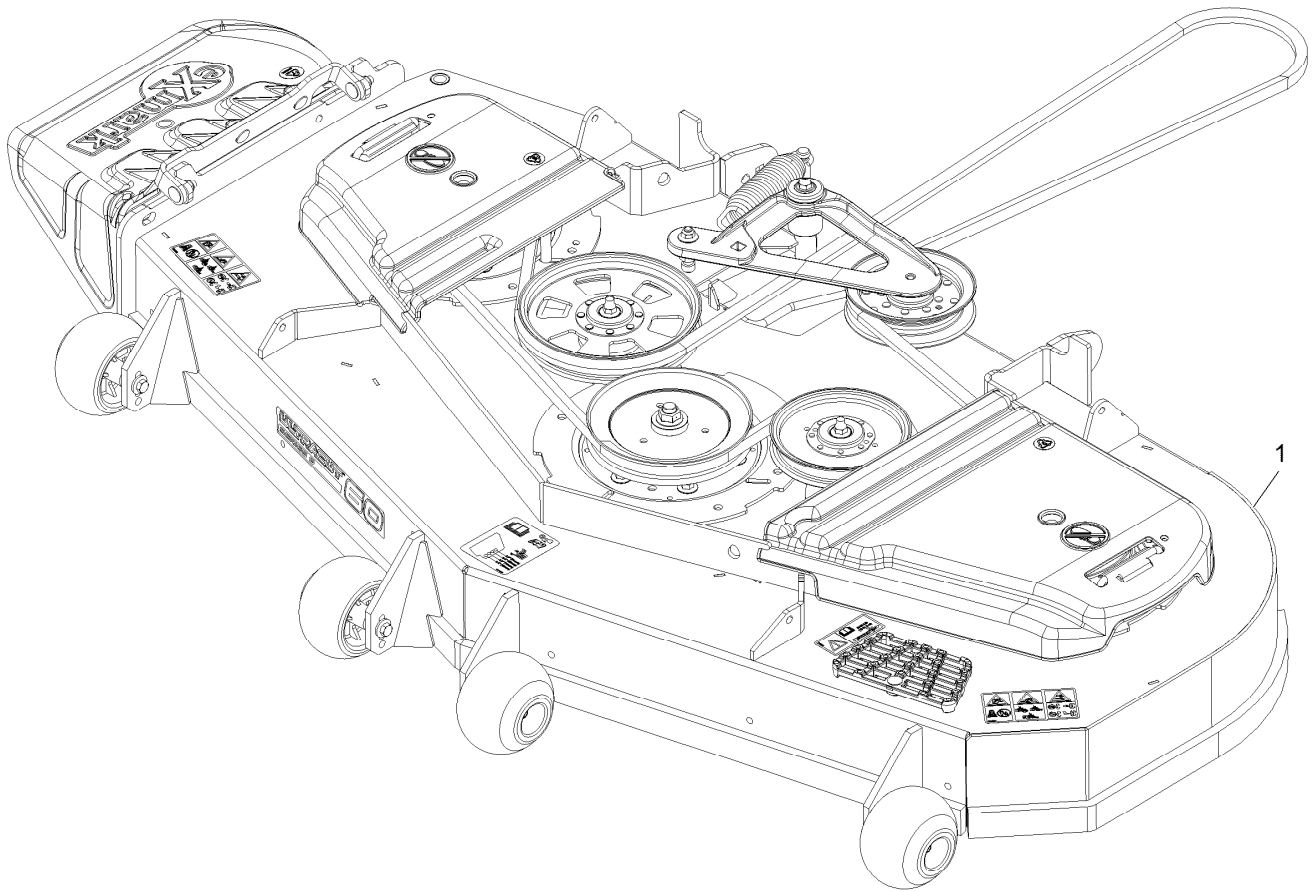

Complete Deck Assembly (continued)

<i>Ref.</i>	<i>Part Number</i>	<i>Qty.</i>	<i>Description</i>
1	109-9647	1	ASM,Deck Complete 606

Deck Assembly

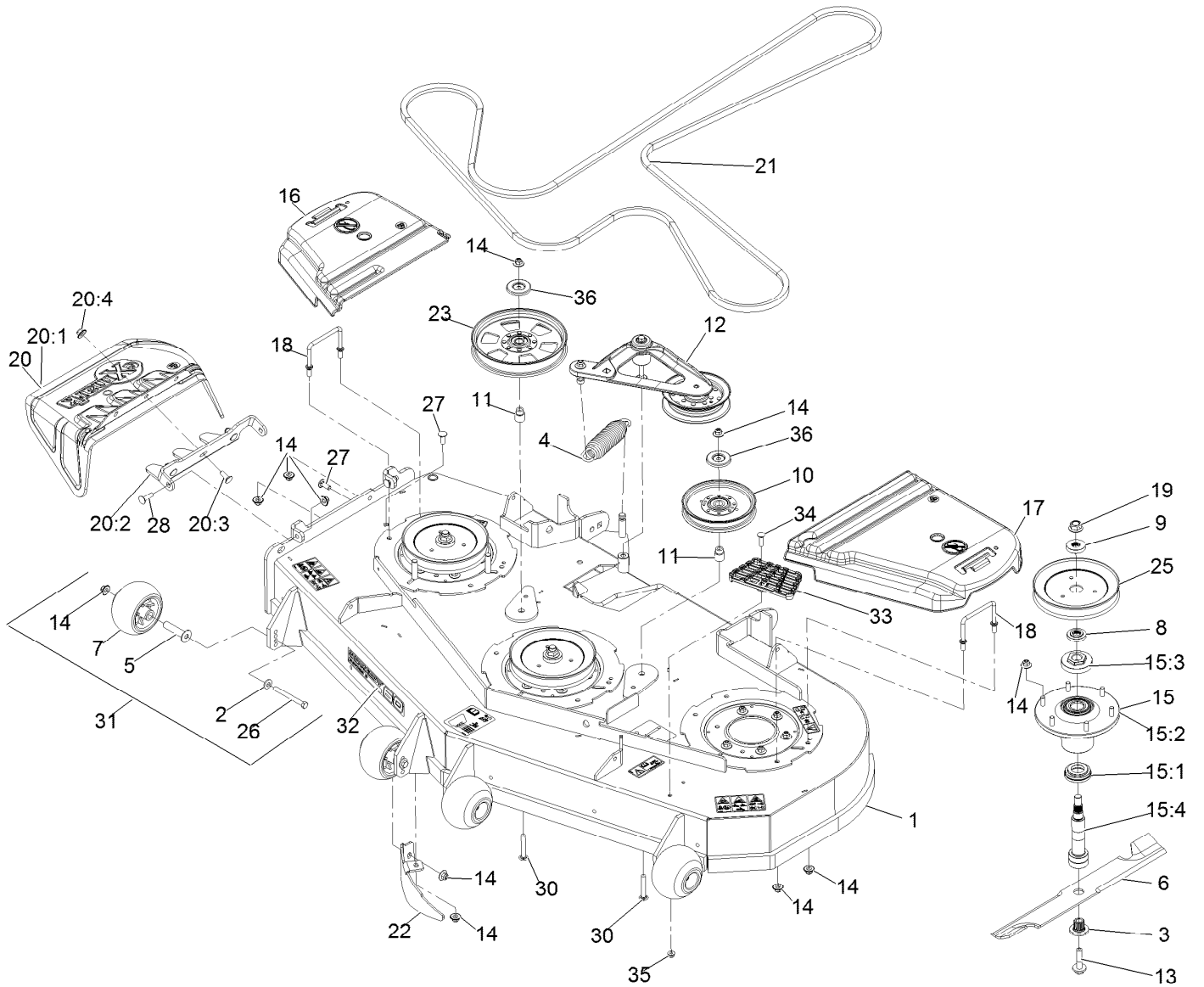

Deck Assembly (continued)

<i>Ref.</i>	<i>Part Number</i>	<i>Qty.</i>	<i>Description</i>	<i>Ref.</i>	<i>Part Number</i>	<i>Qty.</i>	<i>Description</i>
1	116-4232	1	Deck ASM,W/Decals 60	17	109-6938	1	Cover-Belt, LH
2	98-5975	4	Washer-Spring Disc 3/8	18	109-6982	2	Wireform-Cover
3	103-3037	3	Bushing, Splined	19	109-7033	3	Nut-Flange 5/8-18 Centerlock ▲
4	116-6317	1	Spring-Extension	20	109-7188	1	ASM,Discharge Chute
5	116-8131	4	Axle, Roller	20:1	109-2738	1	Chute, Discharge
6	103-6383	3	Blade, Solid ●	20:2	109-8675-01	1	Bracket,Discharge Chute
6	103-6388	3	Blade, Low Lift ●	20:3	3231-22	3	Bolt-Carriage 3/8-16 X 1
6	103-6393	3	Blade, Mulching □	20:4	109-6658	3	Nut-Nyloc 3/8-16 Flg
6	103-6403	3	Blade, Notched	21	109-8073	1	Belt,V-5V-198.75
6	116-5174	3	Blade-Extreme 2, 20.50" ●	22	116-5614-01	1	Dogleg - Lz60
7	103-8415	4	Roller-Anti-Scalp	23	116-9639	1	Pulley-Idler, Flat
8	103-9522	3	Spacer, Splined Stepped	25	109-9511	3	Sheave,Blade Drive 7.25
9	103-9523	3	Spacer, Splined	26	116-9362	4	Screw-HH 3/8-16 X 3 3/4 GR 8
10	126-7685	1	Idler-Pulley, Flat 6.00X0.75	27	3231-22	2	Bolt-Carriage 3/8-16 X 1
11	1-633456	2	Bushing, Idler	28	3231-28	2	Bolt-Carriage 3/8-16 X 1 1/4
12	116-3755	1	Deck Idler ASM	30	3231-44	2	Bolt-Carriage 3/8-16 X 2 1/2
13	109-9220	3	Screw-Sems 1/2-20 X 2.19 ■	31	116-9981	4	Kit, Anti-Scalp Roller
14	109-6658	32	Nut-Nyloc 3/8-16 Flg	32	126-6592	1	Decal, 606
15	109-6917	3	ASM,Spindle Housing	33	126-4781-03	1	Step-Deck
15:1	103-9504	1	Guard, Bottom	34	3230-3	1	Bolt-Carriage 5/16-18 X 1 1/4
15:2	103-9539	1	Asm, Cutter Housing	35	104-8300	1	Nut-Nyloc 5/16-18 Flg
15:3	109-0916	1	Nut, Spindle 7/8-14 ◆	36	126-8043	2	Shield-Dust
15:4	109-6881	1	Spindle,Double Spline ○				
16	116-0094	1	Cover-Belt, RH				

● Optional Equipment

▲ Torque to 90-110 ft-lb

□ Requires installation of mulch kit for proper mulching. See your Exmark dealer for details.

○ Apply Mobil HTS grease (P/N 103-5217 1.5 oz packet) (or a food-grade anti-seize). See operator s manual for locations.

▶ Apply lubricant to threads as needed to prevent seizing. Copper based anti-seize preferable. Grease is an acceptable substitute.

■ Torque to 55-60 ft-lb

◆ Torque to 160-185 ft-lb

Deck W/Decals Assembly No. 116-4232

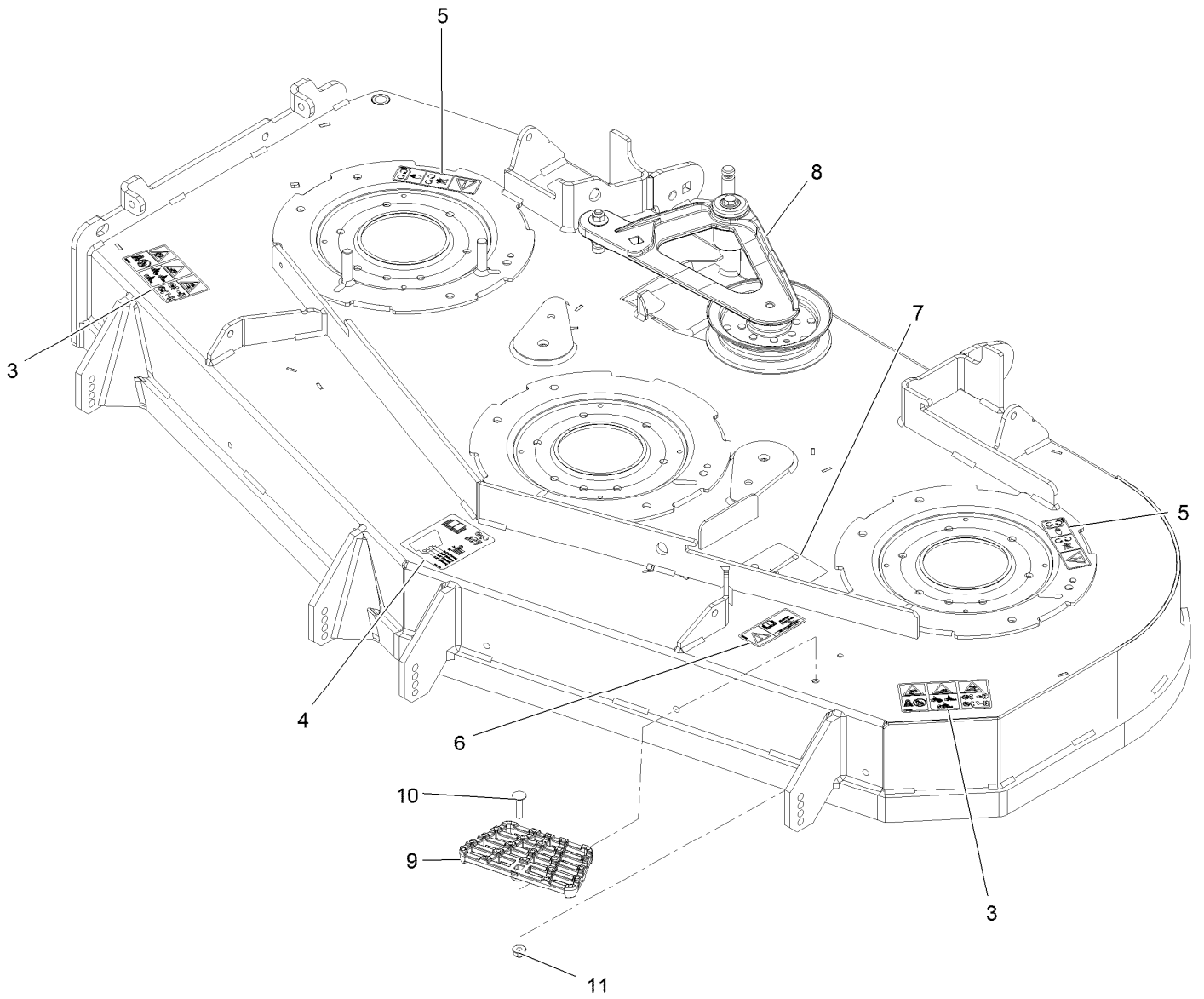

Deck W/Decals Assembly No. 116-4232 (continued)

<i>Ref.</i>	<i>Part Number</i>	<i>Qty.</i>	<i>Description</i>	<i>Ref.</i>	<i>Part Number</i>	<i>Qty.</i>	<i>Description</i>
3	126-6464	2	Decal-Danger Thrown Objects	8	116-3755	1	Deck Idler ASM
4	109-6036	1	Decal-Roller, Anti-Scalp	9	126-4781-03	1	Step-Deck
5	112-9028	2	Decal-Missing, Cover	10	3230-3	1	Bolt-Carriage 5/16-18 X 1 1/4
6	116-8283	1	Decal-Bolt Torque	11	104-8300	1	Nut-Nyloc 5/16-18 Flg
7	116-8727	1	Decal-Belt Routing				

Idler Assembly

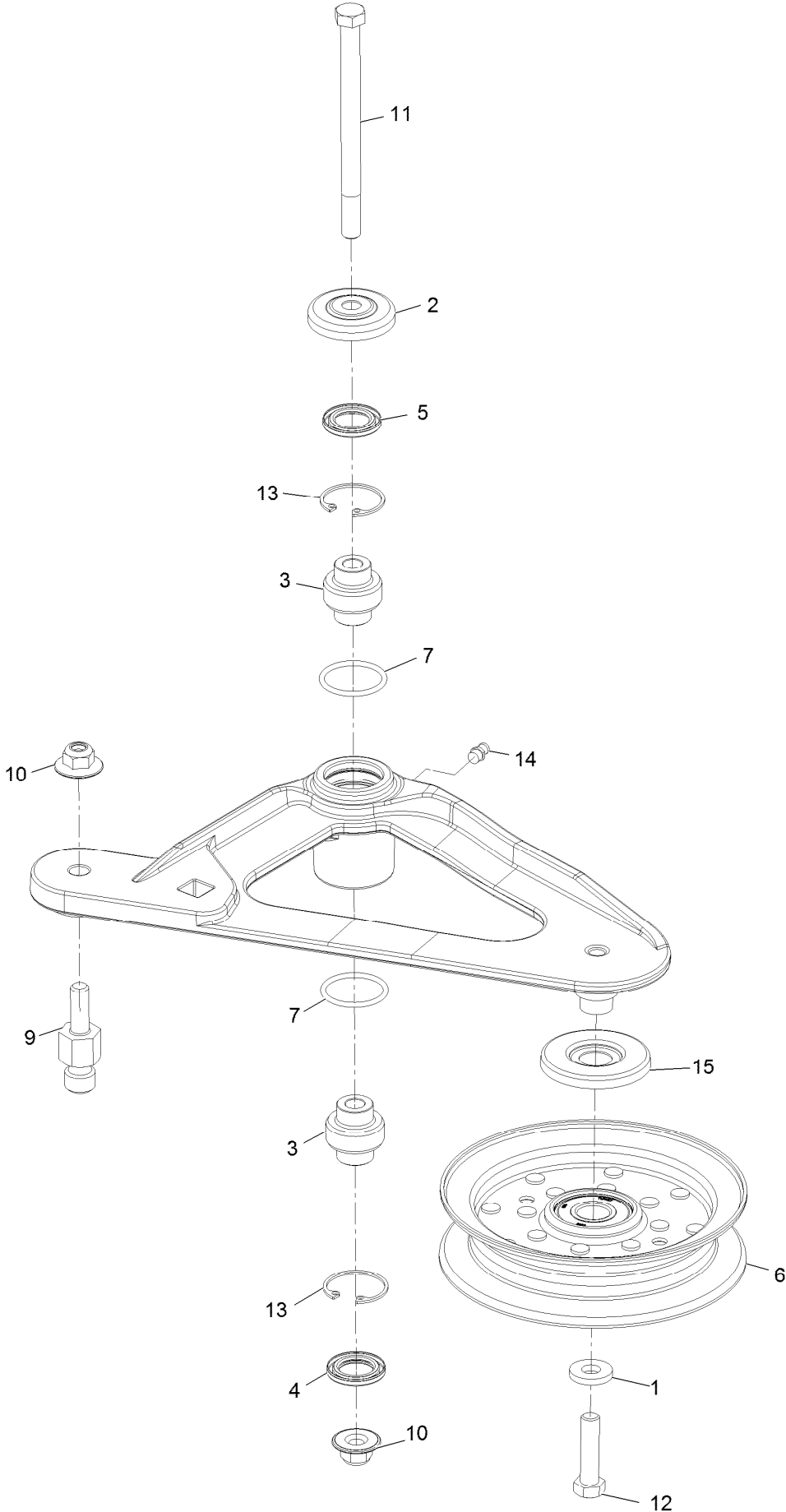

Idler Assembly (continued)

<i>Ref.</i>	<i>Part Number</i>	<i>Qty.</i>	<i>Description</i>	<i>Ref.</i>	<i>Part Number</i>	<i>Qty.</i>	<i>Description</i>
1	43-0940	1	Spacer	9	126-0423	1	Pin-Spring, Anchor
2	103-2916	1	Guard-Top	10	109-6658	2	Nut-Flange, NI
3	103-3504	2	Bearing-Spherical	11	109-7409	1	Screw-Shoulder, HH
4	103-3505	1	Seal-Double Lip	12	323-8	1	Screw-HH
5	103-3506	1	Seal-Lip, Single	13	32120-10	2	Ring-Snap
6	126-9196	1	Idler-Pulley, Flat	14	302-19	1	Fitting-Grease
7	106-7159	2	O-Ring	15	126-9195	1	Shield-Guard, Dust

Cutter Housing Assembly No. 103-9539

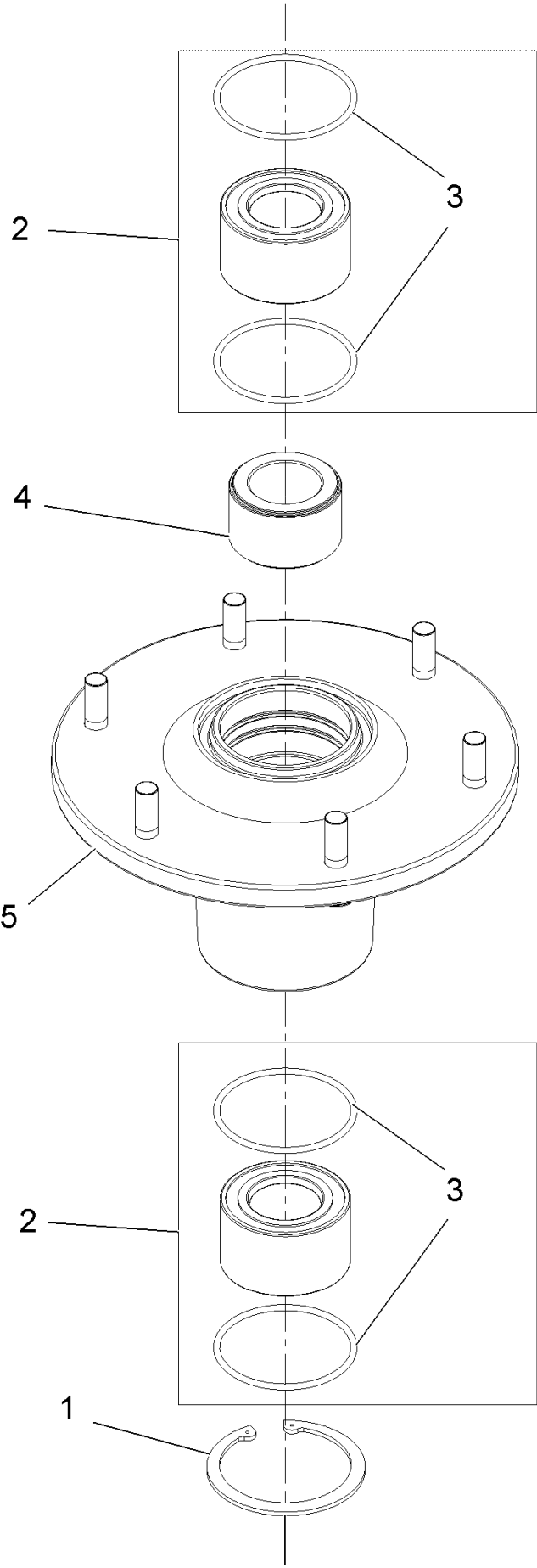

Cutter Housing Assembly No. 103-9539 (continued)

<i>Ref.</i>	<i>Part Number</i>	<i>Qty.</i>	<i>Description</i>	<i>Ref.</i>	<i>Part Number</i>	<i>Qty.</i>	<i>Description</i>
1	92-5581	1	Ring-Retaining	4	103-9506	1	Spacer, Bearing
2	109-2064	1	Asm, Bearing W/O-Rings	5	109-0764	1	Asm, Housing W/Studs
3	103-5895	4	O-Ring				

Main Frame Assembly

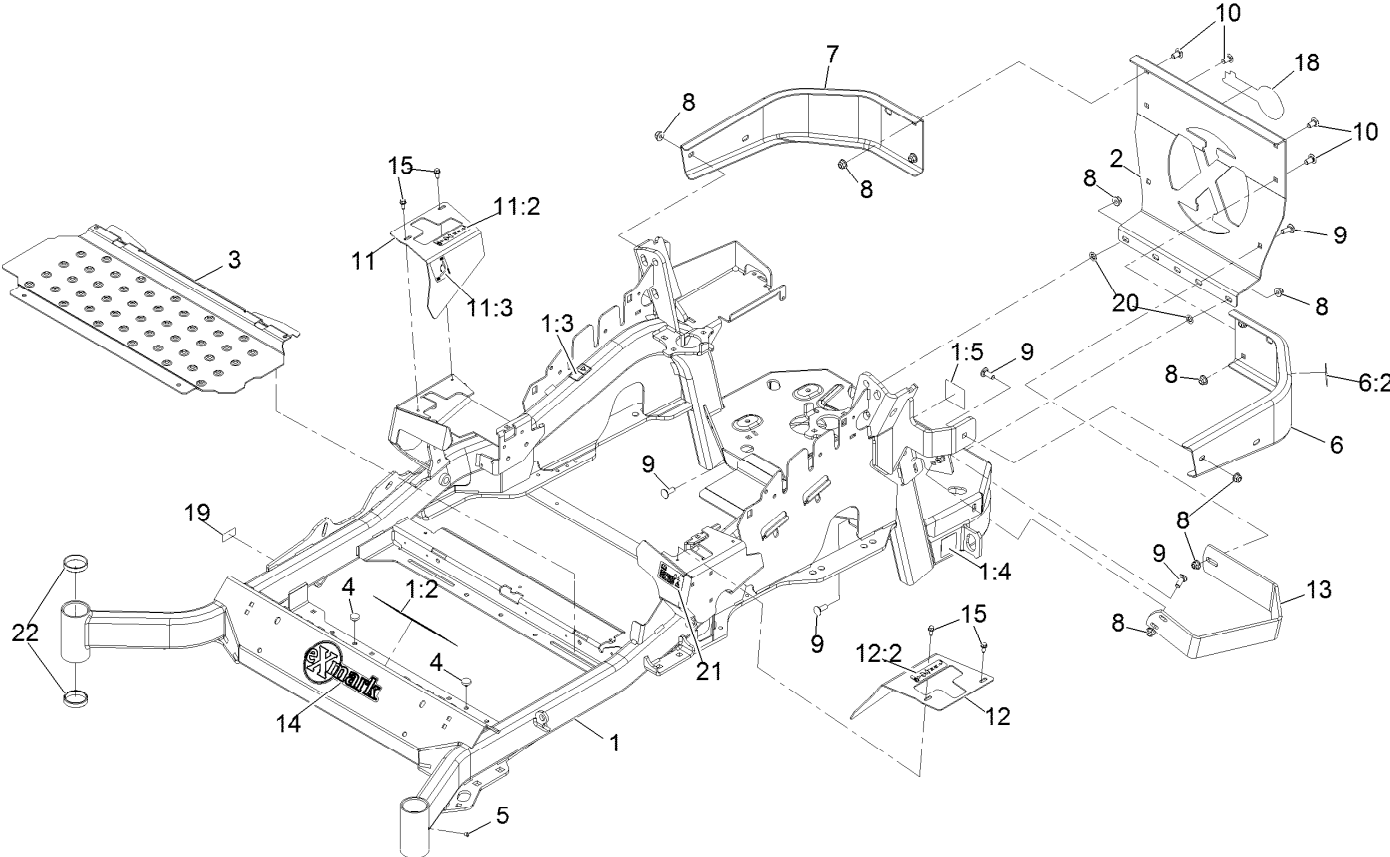

Main Frame Assembly (continued)

<i>Ref.</i>	<i>Part Number</i>	<i>Qty.</i>	<i>Description</i>	<i>Ref.</i>	<i>Part Number</i>	<i>Qty.</i>	<i>Description</i>
1	116-5902	1	Mainframe ASM	11	116-5899	1	RH Motion Control Cover ASM
1:2	132-0871	1	Decal-Danger	11:2	99-8936	1	Decal-Control, Motion
1:3	106-5517	2	Decal-Warning	11:3	116-5988	1	Decal-Park Brake, CE
1:4	106-2655	2	Decal-Hazard, Pinched Finger	12	116-0580	1	LH Motion Control Cover ASM
1:5	116-4858	1	Decal-Spark Arrester	12:2	99-8936	1	Decal-Control, Motion
2	109-8863-03	1	Plate,Rear Guard	13	126-2067-03	1	Guard-Muffler
3	116-8898-01	1	Floorpan	14	126-6969	1	Decal-Exmark Logo
4	1-513658	2	Bumper	15	32144-10	4	Screw-HWH 1/4-20 X .62
5	1-811010	2	Plug	18	126-6965	1	Decal-Exmark Logo
6	116-0180	1	LH Bumper ASM	19	126-4345	1	Decal-Patent
6:2	106-5517	1	Decal-Warning	20	107-3154	2	Nut-Push 3/8-16
7	116-0057-03	1	Bumper-RH	21	117-3864	1	Decal-Fuel Fill, CE
8	104-8301	11	Nut-Nyloc 3/8-16 Flg	22	1-543508	4	Cup-Bearing Tapered Roller
9	3231-22	7	Bolt-Carriage 3/8-16 X 1				
10	3231-21	4	Bolt-Carriage 3/8-16 X 3/4				

X-Series Decal

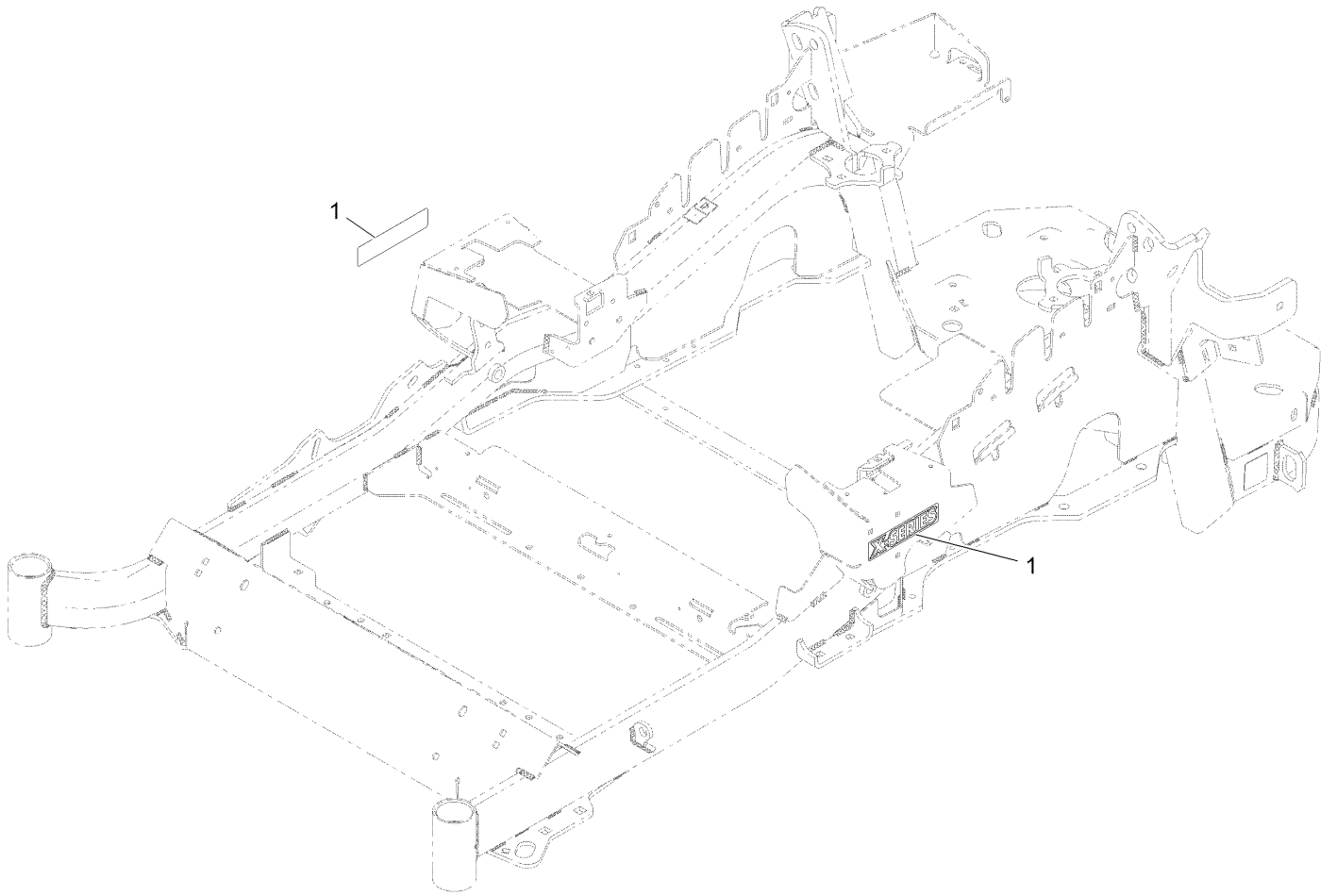

X-Series Decal (continued)

<i>Ref.</i>	<i>Part Number</i>	<i>Qty.</i>	<i>Description</i>
1	126-6573	2	Decal-X-Series

Roll-Over Protection System

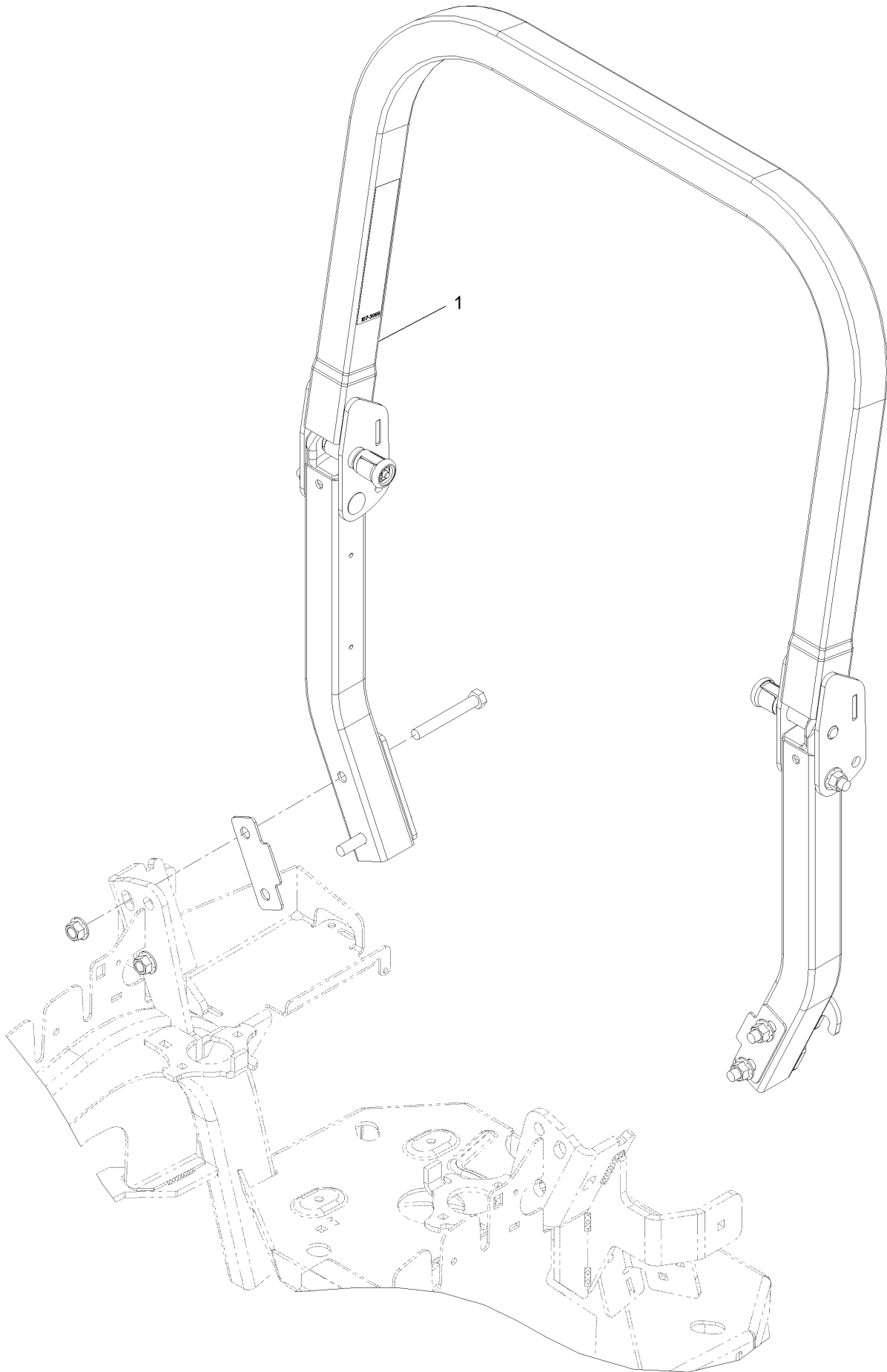

Roll-Over Protection System (continued)

<i>Ref.</i>	<i>Part Number</i>	<i>Qty.</i>	<i>Description</i>
1	116-0230	1	ASM,ROPS Service Exmark

Roll-Over Protection System Assembly No. 116-0230

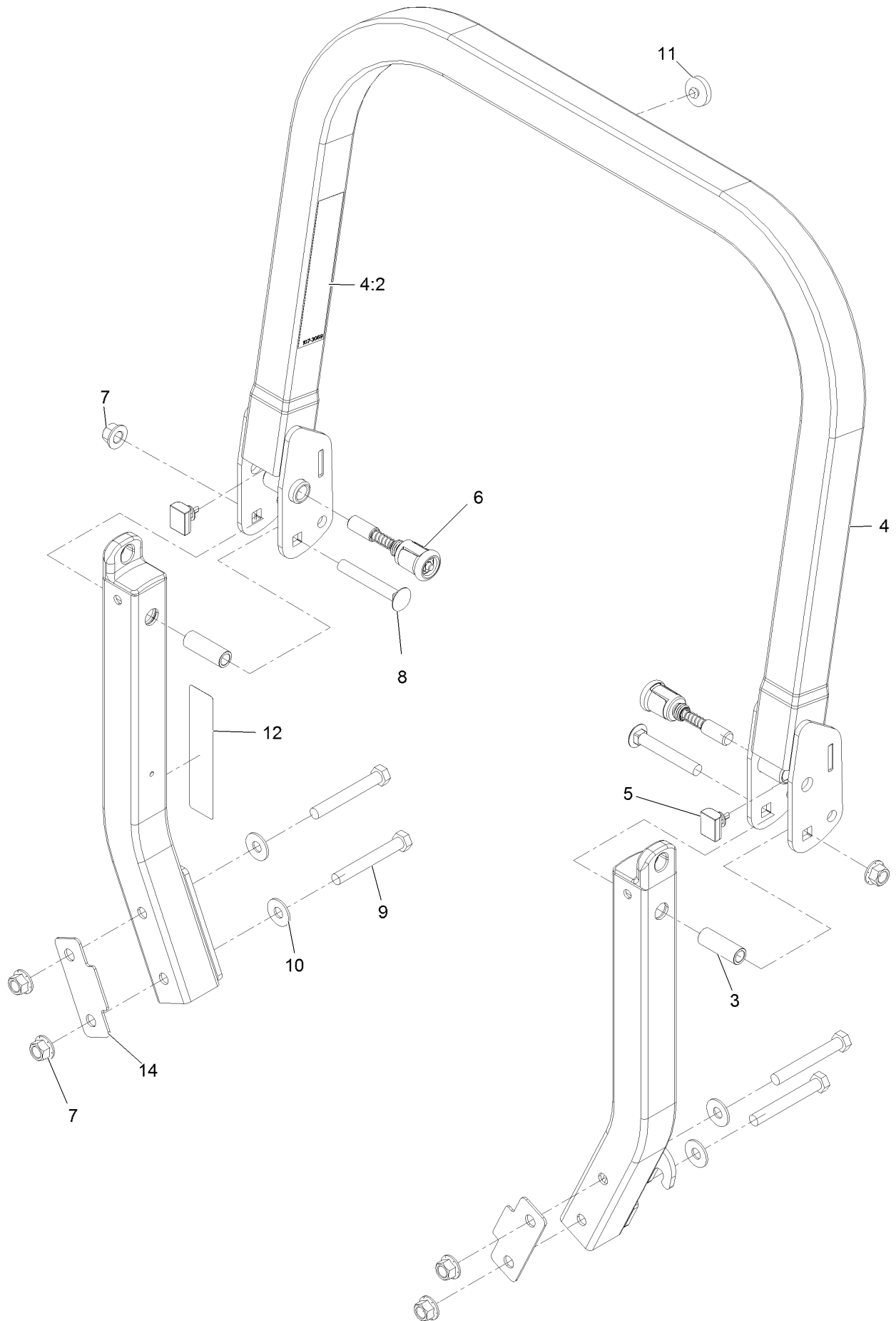

Roll-Over Protection System Assembly No. 116-0230 (continued)

<i>Ref.</i>	<i>Part Number</i>	<i>Qty.</i>	<i>Description</i>	<i>Ref.</i>	<i>Part Number</i>	<i>Qty.</i>	<i>Description</i>
3	109-6653	2	Spacer	8	3233-10	2	Bolt-Carriage 1/2-13 X 3 1/2
4	116-0019	1	Upper ROPS ASM	9	325-35	4	Screw-HH
4:2	107-3069	1	Decal-Warning	10	109-9505	4	Washer, Spring Disc 1/2
5	109-5337	2	Bumper-ROPS	11	109-9233	1	Bumper-Push-In, Rubber
6	116-0104	2	Pin-Spring	12	117-0346	1	Decal-Caution, Fuel Vent
7	99-5107	6	Nut-Lock 1/2-13	14	116-0960	2	Spacer

Front Caster and Fork Assembly

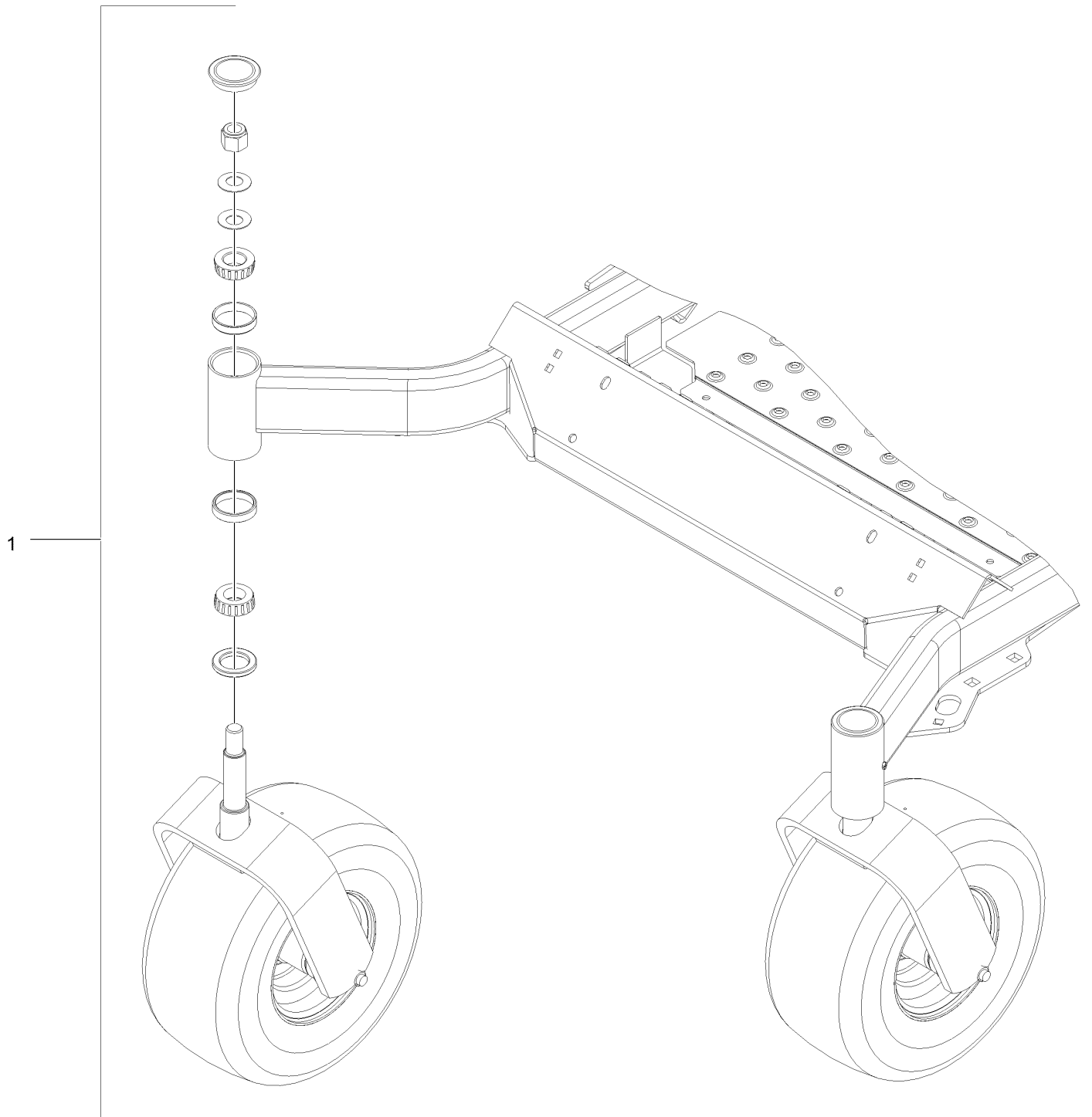

Front Caster and Fork Assembly (continued)

<i>Ref.</i>	<i>Part Number</i>	<i>Qty.</i>	<i>Description</i>
1		2	Caster Wheel ASM ●

● Not serviced separately

Caster Wheel and Fork Assembly

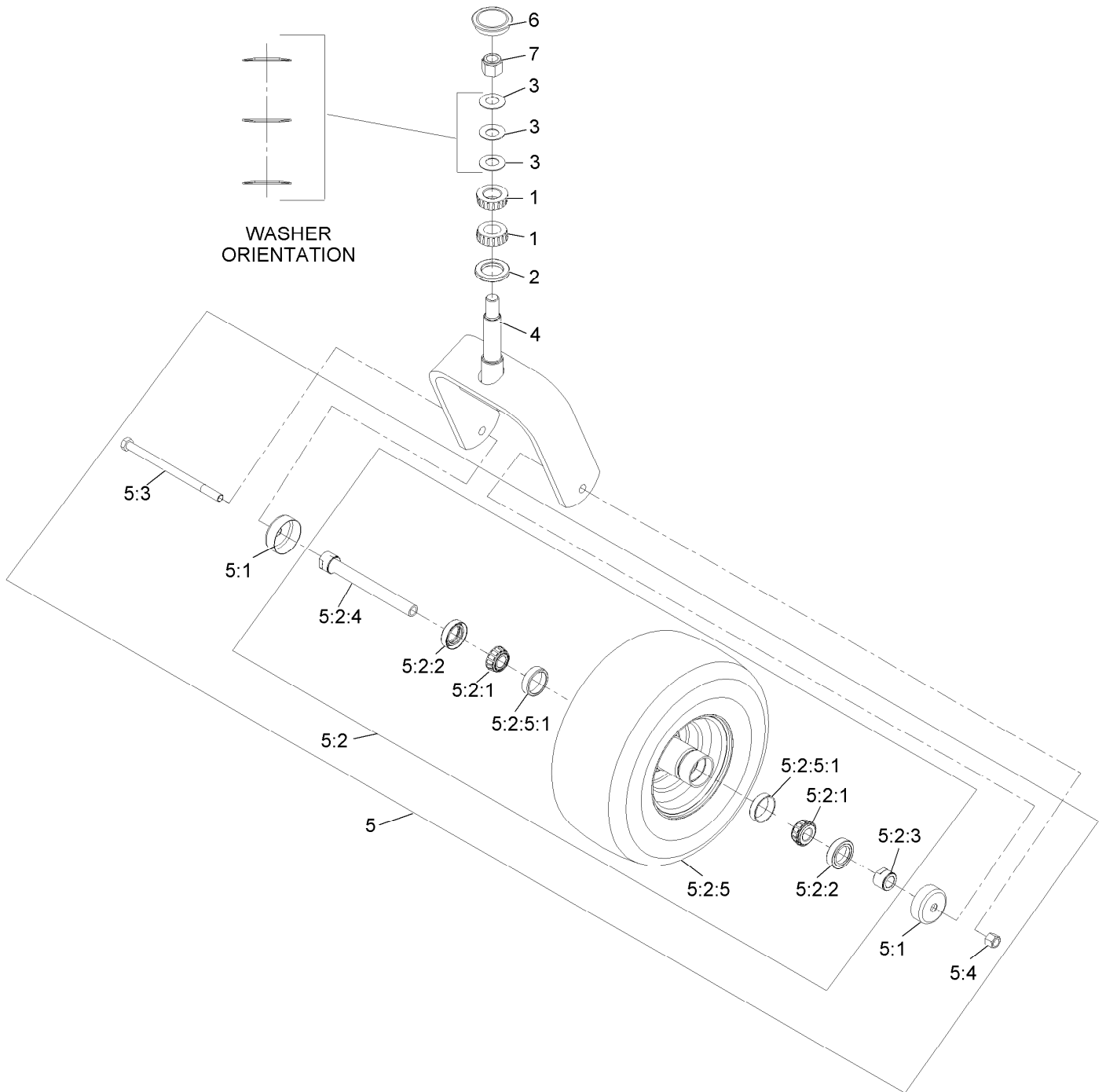

Caster Wheel and Fork Assembly (continued)

<i>Ref.</i>	<i>Part Number</i>	<i>Qty.</i>	<i>Description</i>	<i>Ref.</i>	<i>Part Number</i>	<i>Qty.</i>	<i>Description</i>
1	1-543509	2	Bearing-Roller, Tapered	5:2:3	103-3051	1	Spacer-Nut ■
2	116-5647	1	Seal-Grease	5:2:4	126-5361	1	Axle Caster ASM
3	1-633508	3	Washer-Bellville	5:2:5		1	Wheel And Tire ASM ●
4	116-6707-01	1	Caster	5:2:5:1	1-633584	2	Bearing-Cup
5	109-9127	1	Wheel & Tire ASM	5:3	325-39	1	Screw-HH
5:1	103-2768	2	Guard-Seal	5:4	3296-23	1	Nut-Lock, NI
5:2		1	Wheel And Tire ASM ●	6	103-4882	1	Cap-Grease
5:2:1	1-633585	2	Bearing-Cone, Taper	7	3296-51	1	Nut-Lock, NI
5:2:2	103-0063	2	Seal-Caster				

● Not serviced separately

■ Use Pro-Lock, Nut Type (P/N 1-840022, .5ml tube) on threads.

Deck Lift Assembly

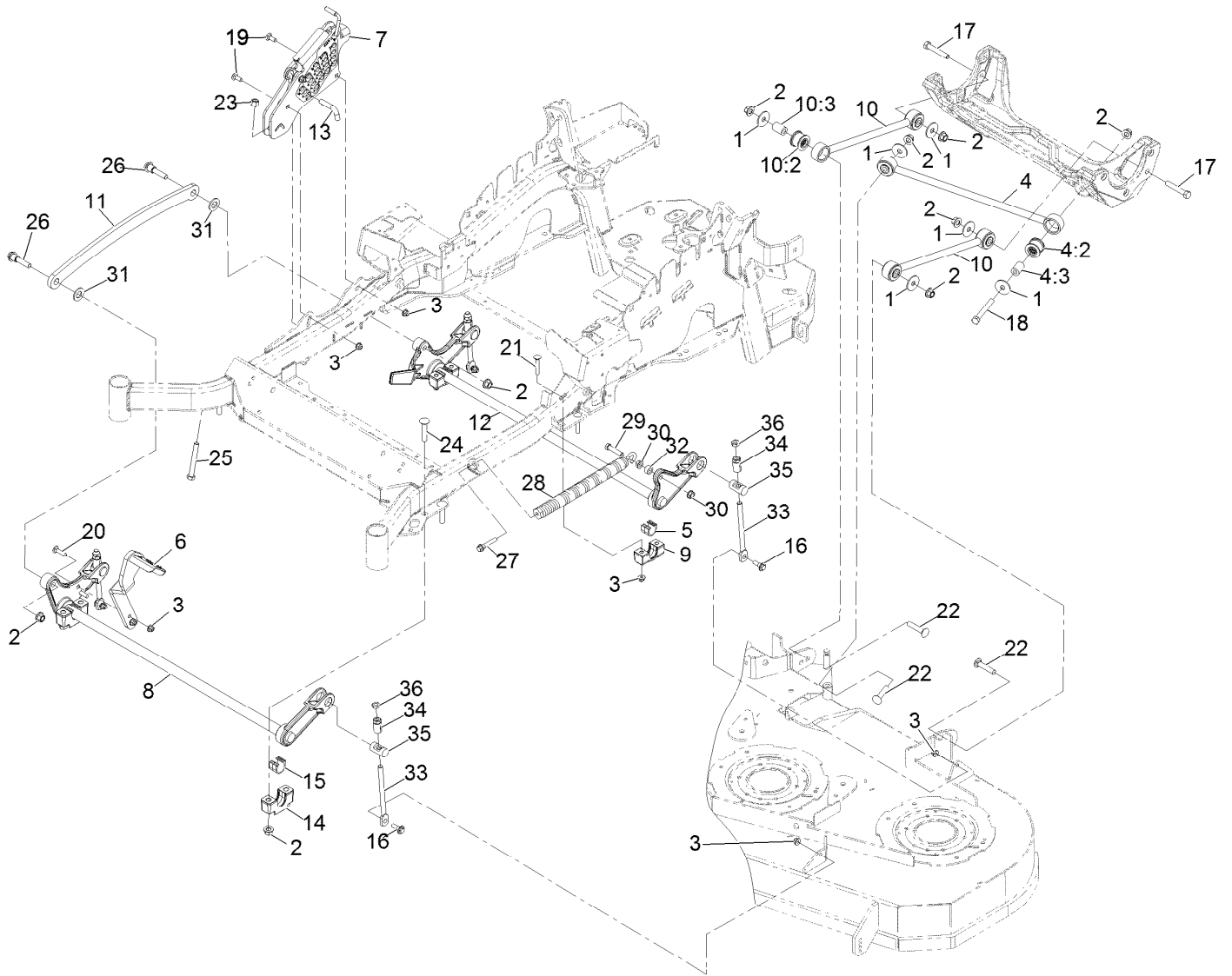

Deck Lift Assembly (continued)

<i>Ref.</i>	<i>Part Number</i>	<i>Qty.</i>	<i>Description</i>	<i>Ref.</i>	<i>Part Number</i>	<i>Qty.</i>	<i>Description</i>
1	86-1990	6	Washer	17	325-12	2	Screw-HH 1/2-13 X 3
2	99-5107	12	Nut-Lock 1/2-13	18	325-17	1	Screw-HH 1/2-13 X 4
3	104-8301	12	Nut-Nyloc 3/8-16 Flg	19	3231-2	2	Bolt-Carriage 3/8-16 X 1
4	109-5013	1	Panhard Rod ASM	20	3231-4	2	Bolt-Carriage 3/8-16 X 1 1/2
4:2	109-5009	2	Bushing-Suspension, Rubber	21	3231-7	4	Bolt-Carriage 3/8-16 X 2 1/4
4:3	109-5010	2	Spacer	22	3233-34	3	Bolt-Carriage 1/2-13 X 2 1/2
5	109-7173	2	Bearing-Cross Shaft, Rear	23	3296-23	1	Nut-Nyloc 1/2-13
6	116-1919-01	1	Lever-Foot	24	116-1700	4	Bolt-Carriage 1/2-13 X 2 1/2 Spl Neck
7	109-7438	1	HOC ASM	25	116-0559	1	Bolt-HH 1/2-13 X 4 Tap
8	126-2477-03	1	Decklift-Front	26	116-2022	2	Screw-Hex Flange 1/2-13 X 1.90
9	127-0553	2	Support-Cross Shaft, Bearing Rear	27	92-7674	1	Screw-Shcs 3/8-16 X 2.212
10	109-7952	2	Deck Strut ASM	28	116-0000	1	Spring-Extension
10:2	109-5009	2	Bushing-Suspension, Rubber	29	109-9065	1	Screw-HH 7/16-14 X 2
10:3	109-5010	2	Spacer	30	32128-37	2	Nut-Whizlock 7/16-14
11	116-0797-03	1	Link-Lift, Deck	31	3256-28	2	Washer-3/4 SAE
12	116-2645-03	1	Lift-Deck, Rear	32	116-2695	1	Spacer
13	116-5584	1	Pin-HOC	33	109-8007	4	Link-Adjuster, Deck Lift
14	109-9409	2	Support-Cross Shaft, Bearing	34	109-7840	4	Adjuster-Lift, Deck
15	109-9410	2	Bearing-Cross Shaft, Front	35	109-8353	4	Trunnion
16	109-9840	4	Screw-Hex Flange 3/8-16 X .80	36	3218-5	4	Nut-Jam 1/2-13

Height-of-Cut Assembly No. 109-7438

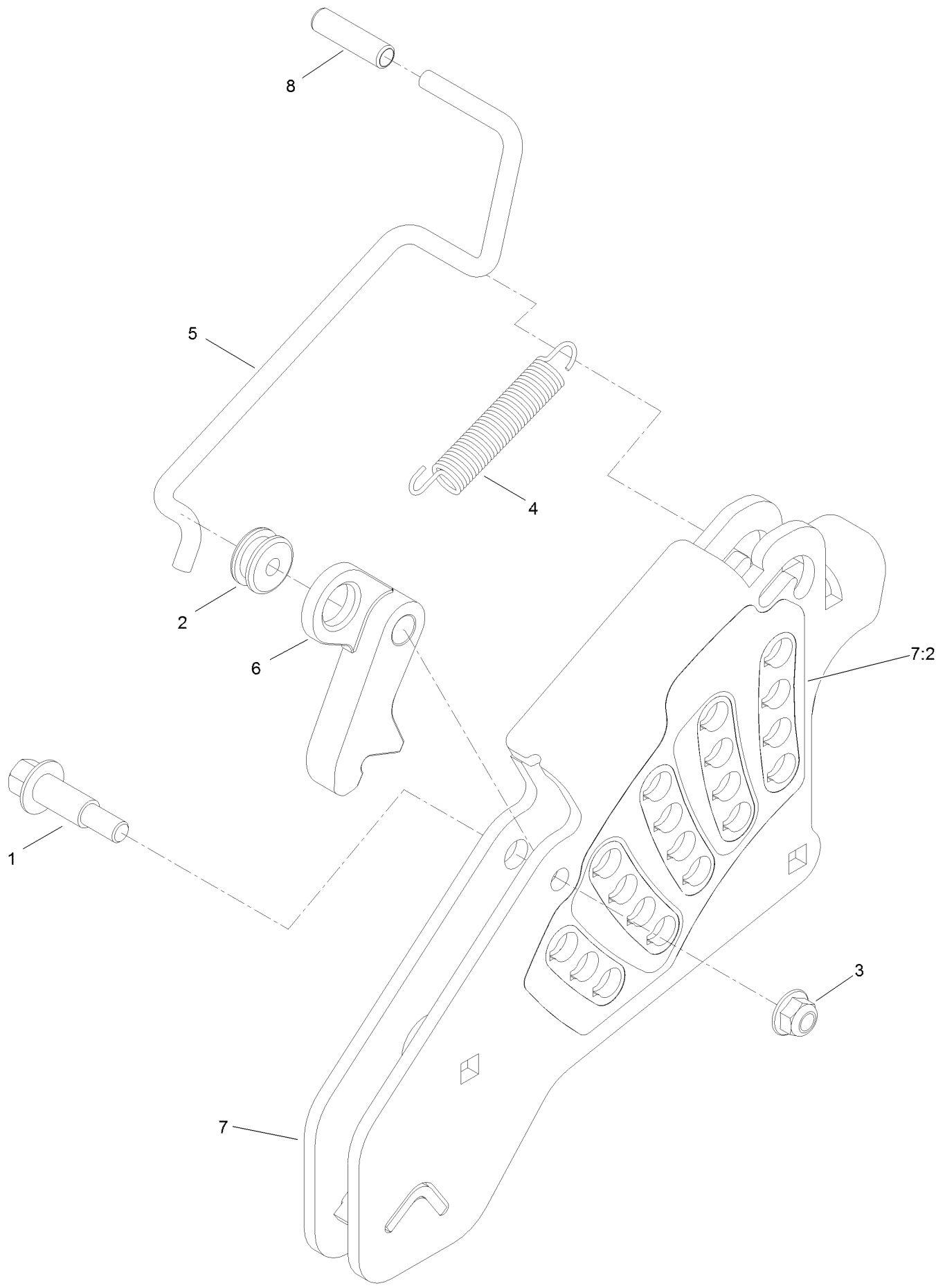

Height-of-Cut Assembly No. 109-7438 (continued)

<i>Ref.</i>	<i>Part Number</i>	<i>Qty.</i>	<i>Description</i>	<i>Ref.</i>	<i>Part Number</i>	<i>Qty.</i>	<i>Description</i>
1	62-1330	1	Bolt-Shoulder	6	116-0118	1	Pawl-Transport, HOC
2	109-7130	1	Grommet	7	109-7335	1	HOC Plate ASM
3	104-8301	1	Nut-Flange, NI	7:2	126-4398	1	Decal-HOC
4	109-7124	1	Spring-Extension	8	109-8250	1	Grip-Lever
5	109-7128	1	Rod-Lock, Transport				

Controls Assembly

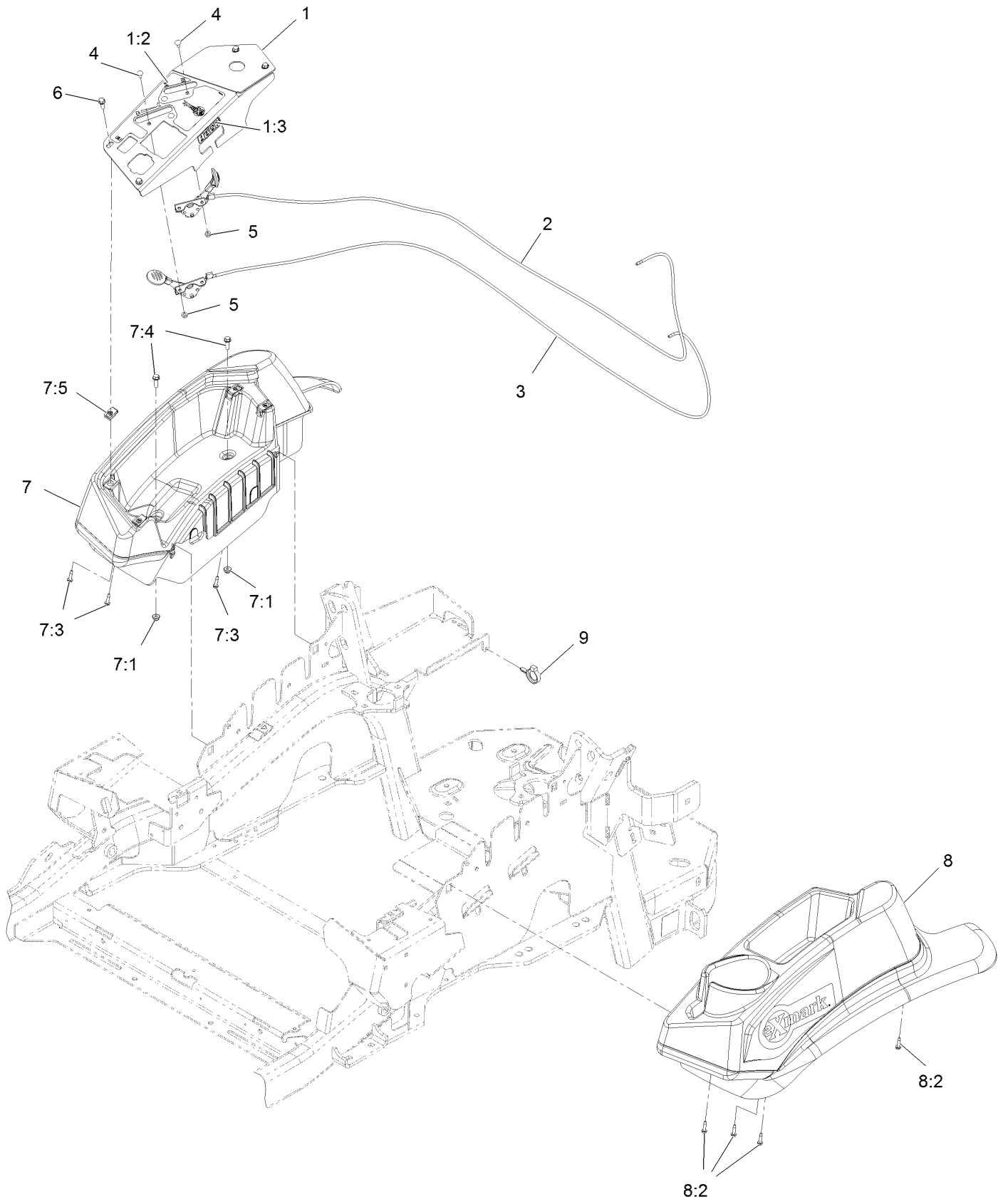

Controls Assembly (continued)

<i>Ref.</i>	<i>Part Number</i>	<i>Qty.</i>	<i>Description</i>	<i>Ref.</i>	<i>Part Number</i>	<i>Qty.</i>	<i>Description</i>
1	109-8484	1	Console,Panel W/Decal	7	109-9341	1	Console,RH Narrow ASM
1:2	116-8724	1	Decal-Control Panel Non-Efi	7:1	104-7201	2	Nut-Nyloc 1/4-20 Flg
1:3	114-4466	1	Decal-Fuses	7:3	109-9345	3	Screw-HWH #10-14 X 3/4 Tf
2	109-8167	1	ASM, Choke Cable	7:4	32105-15	2	Screw-Machine 1/4-20 X 3/4
3	116-1972	1	ASM,Throttle Cable	7:5	107069	4	Nut-Retainer-Panel 1/4-20
4	1-807513	4	Bolt-Carriage #10-24 X 1/2	8	109-9342	1	Console.LH Narrow ASM
5	3296-2	4	Nut-Nyloc #10-24	8:2	109-9345	4	Screw-HWH #10-14 X 3/4 Tf
6	32105-15	4	Screw-Machine 1/4-20 X 3/4	9	105-1853	1	Clamp-Hose

Motion Control Assembly

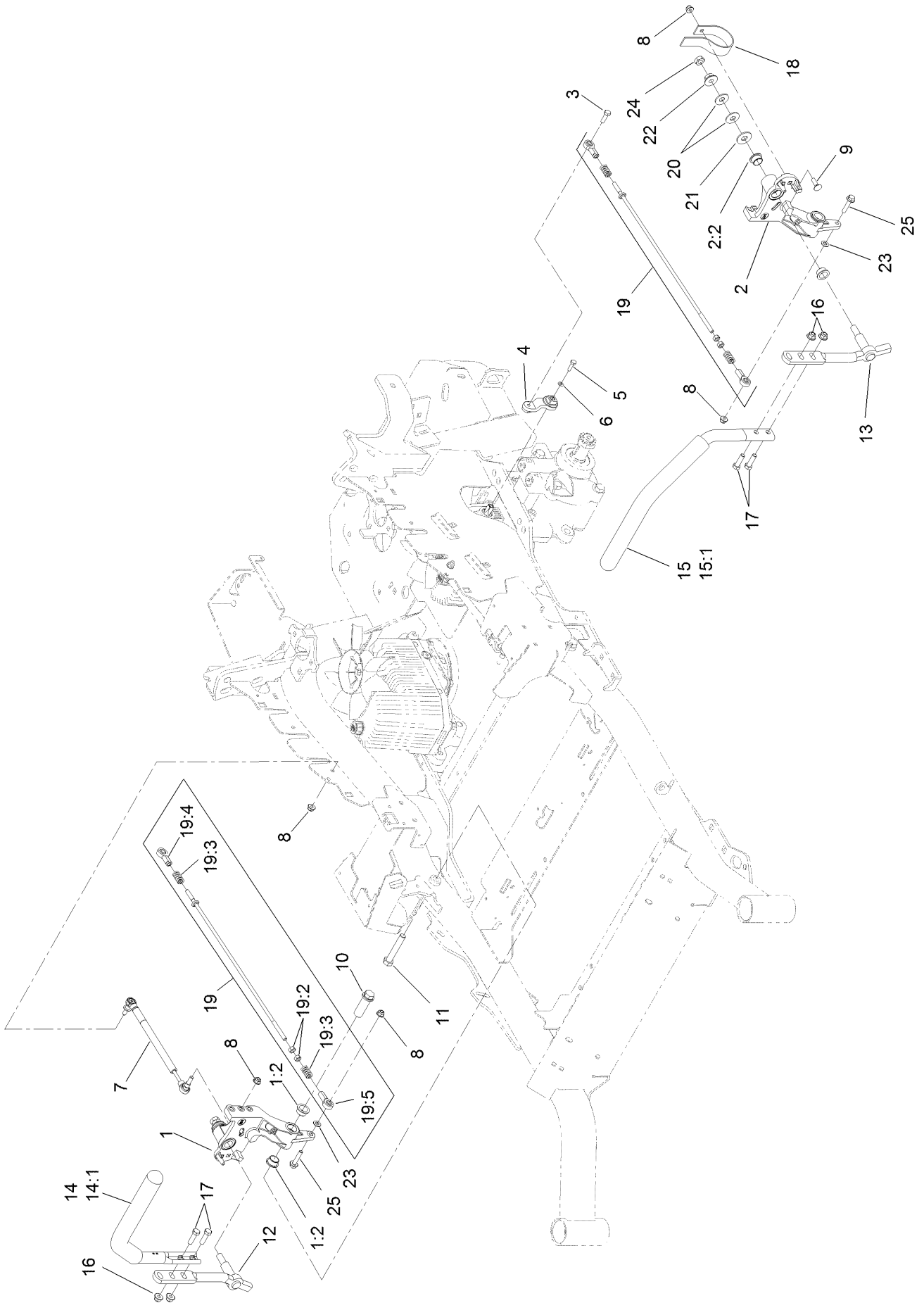

Motion Control Assembly (continued)

<i>Ref.</i>	<i>Part Number</i>	<i>Qty.</i>	<i>Description</i>	<i>Ref.</i>	<i>Part Number</i>	<i>Qty.</i>	<i>Description</i>
1	116-0880	1	RH Motion Control And Bushing ASM	14	109-6589	1	RH Steering Handle ASM
1:2	109-8054	4	Bushing-Flange	14:1	109-5668	1	Grip-Control, Lever
2	116-0881	1	LH Motion Control And Bushing ASM	15	109-6590	1	LH Steering Handle ASM
2:2	109-8054	4	Bushing-Flange	15:1	109-5668	1	Grip-Control, Lever
3	116-0648	2	Screw-HH, Thread Locking ●	16	104-8301	4	Nut-Flange, NI
4	109-4581	2	Arm-Control, Pump	17	323-7	4	Screw-HH
5	9080046	2	Screw-HH ●	18	109-5575	2	Spring-Leaf
6	1-303435	2	Washer-Spring	19	109-8106	2	Front Pump Linkage ASM
7	116-0027	2	Damper-Control, Motion	19:2	3219-2	2	Nut-Hex
8	104-8300	8	Nut-Flange, NI	19:3	1-323245	2	Spring-Compression
9	3230-2	2	Bolt-CARR	19:4	1-633152	1	Balljoint-LH
10	109-5891	2	Hub-Threaded	19:5	1-543017	1	Balljoint-RH
11	325-12	2	Screw-HH	20	109-9505	4	Washer-Spring
12	116-0039	1	Lever-Control Motion, RH	21	3256-6	2	Washer-Flat
13	116-0040	1	Lever-Control Motion, LH	22	32128-56	2	Nut-HF
				23	3256-23	2	Washer-Flat
				24	3218-5	2	Nut-Jam
				25	115-1794	2	Screw-HHF

● Use Pro-Lock, Nut Type (P/N 1-840022, .5ml tube) on threads.

Rear Wheel Assembly

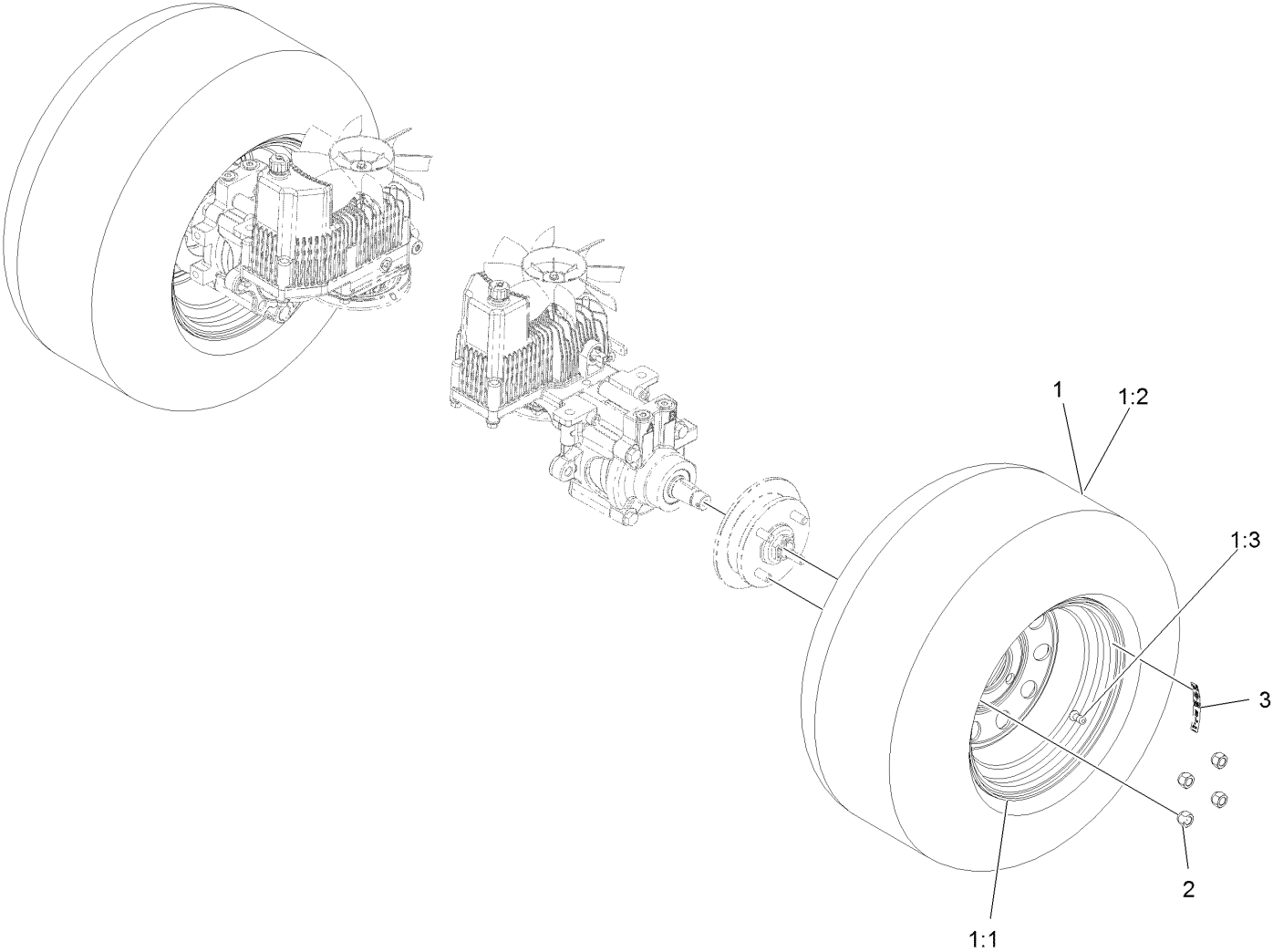

Rear Wheel Assembly (continued)

<i>Ref.</i>	<i>Part Number</i>	<i>Qty.</i>	<i>Description</i>	<i>Ref.</i>	<i>Part Number</i>	<i>Qty.</i>	<i>Description</i>
1	115-3588	2	Wheel And Tire ASM	2	242-50	8	Nut-Lug 1/2-20
1:1	109-2871	1	Rim	3	126-2055	2	Decal-Torque, Wheel Hub Lug
1:2	1-633993	1	Tire				
1:3	232-27	1	Stem-Valve				

Park Brake Assembly

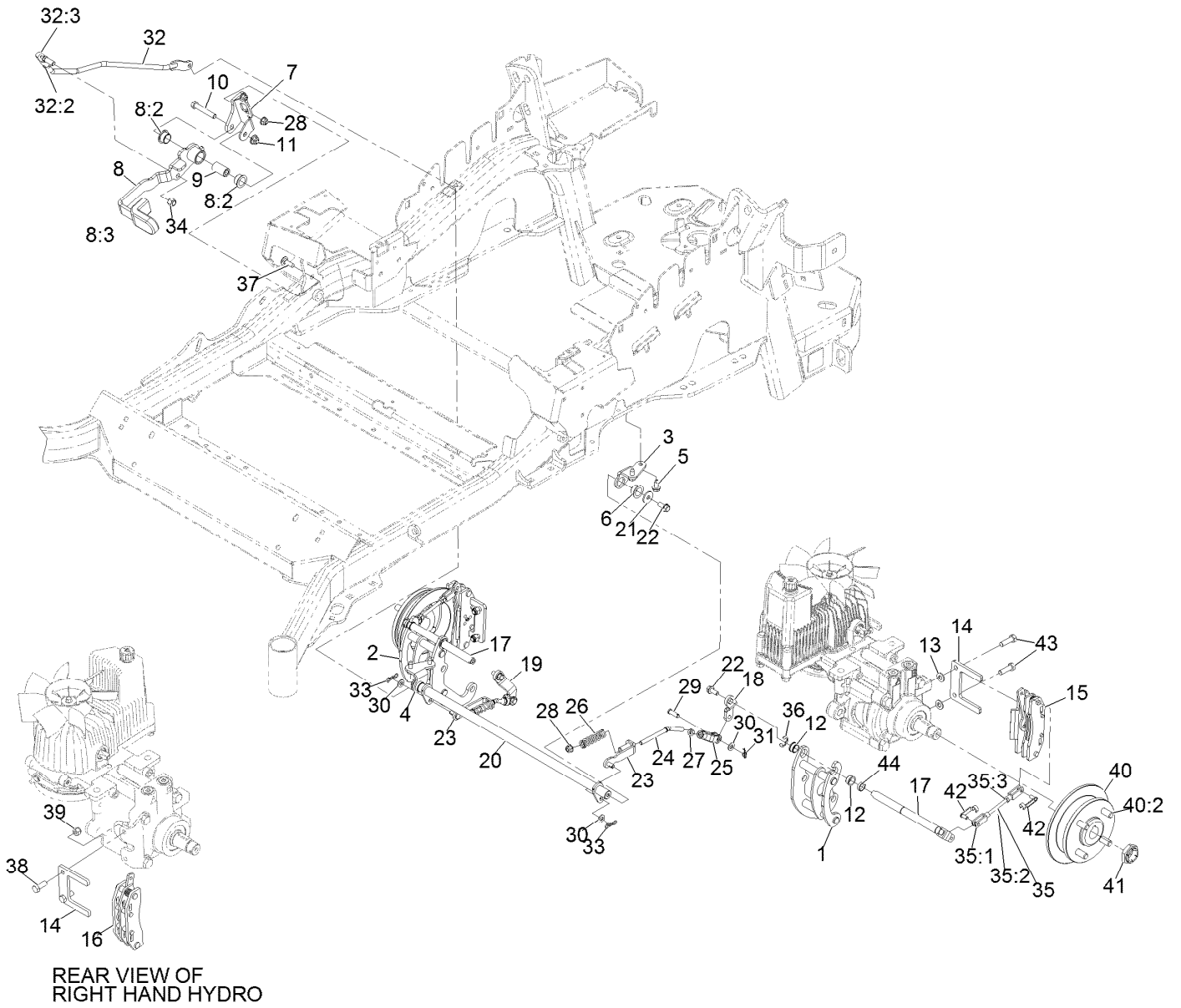

Park Brake Assembly (continued)

<i>Ref.</i>	<i>Part Number</i>	<i>Qty.</i>	<i>Description</i>	<i>Ref.</i>	<i>Part Number</i>	<i>Qty.</i>	<i>Description</i>
1	126-4248	1	Mount-Bellcrank, LH	26	116-9085	2	Spring-Compression
2	126-4249	1	Mount-Bellcrank, RH	27	3220-2	2	Nut-Jam 5/16-24
3	116-9681	1	Mount-Pivot, LH	28	104-8300	4	Nut-Nyloc 5/16-18 Flg
4	116-9682	1	Mount-Pivot, RH	29	1-808280	2	Pin-Clevis 5/16 X 1 49/64
5	32144-70	4	Screw-HWH 5/16-18 X 3/4 Tf	30	3256-23	4	Washer-5/16 SAE
6	109-8054	2	Bushing-Flanged	31	116-6639	2	Pin-Cotter, Locking
7	116-9096-01	1	Bracket-Mount	32	116-9102	1	Front Linkage ASM
8	132-9406	1	Brake Lever ASM W/ Grip	32:2	94-7572	1	End-Tie Rod, RH
8:2	109-8054	2	Bushing-Flanged	32:3	3220-3	1	Nut-Jam 3/8-24
8:3	132-4749	1	Grip-Lever	33	119-1415	2	Pin-Cotter, Locking
9	116-9117	1	Handle-Pivot, Brake	34	3296-6	1	Nut-Nyloc 3/8-24
10	323-11	1	Screw-HH 3/8-16 X 2 1/4	35	126-7587	2	Rear Linkage ASM
11	104-8301	1	Nut-Nyloc 3/8-16 Flg	35:1	126-7588	2	Yoke
12	126-6199	4	Bushing-Igus	35:2	116-9069	1	Linkage, Rear
13	3256-24	2	Washer-3/8 SAE	35:3	3220-1	1	Nut-Jam 1/4-28
14	109-0958	2	Plate-Mount, Brake	36	32120-19	2	E-Ring
15	109-2889	1	Caliper-Brake	37	3230-2	2	Bolt-Carriage 5/16-18 X 1
16	116-9103	1	Caliper-Brake, RH	38	323-6	2	Screw-HH 3/8-16 X 1
17	126-4251	2	Bellcrank	39	3296-39	2	Nut-Nyloc 3/8-16
18	126-3715	1	Arm-Inner, LH	40	116-1746	2	Wheel Hub ASM
19	126-3716	1	Arm-Inner, RH	40:2	116-1696	4	Stud-Wheel
20	116-9080	1	Shaft-Cross	41	116-1399	2	Locknut
21	115-7109	2	Washer-Flat	42	126-6395	4	Pin-Clevis, Spring
22	98-9940	4	Screw	43	92-5727	2	Screw-HH 3/8-16 X 1 1/4 Patch Lock
23	116-9609	2	Bracket-L	44	126-6200	2	Spacer
24	116-9086	2	Linkage-Mid				
25	126-3693	2	Yoke-Offset				

Seat Assembly

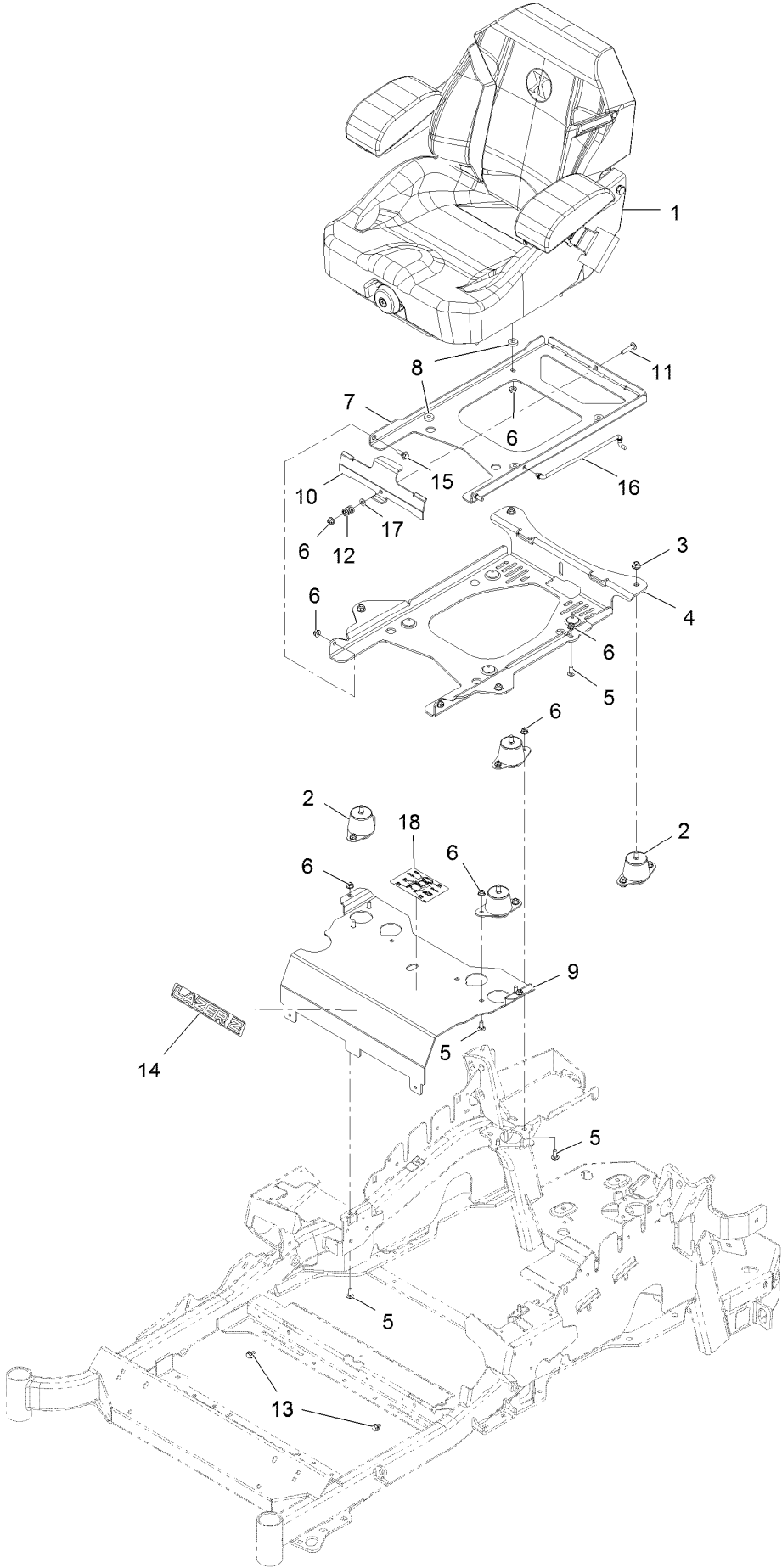

Seat Assembly (continued)

<i>Ref.</i>	<i>Part Number</i>	<i>Qty.</i>	<i>Description</i>	<i>Ref.</i>	<i>Part Number</i>	<i>Qty.</i>	<i>Description</i>
1	116-8912	1	Kit-Suspension Seat	10	109-9881-03	1	Plate-Latch, Seat
2	109-9034	4	Isolator-Seat	11	3230-4	1	Bolt-Carriage 5/16-18 X 1 1/2
3	104-8301	4	Nut-Nyloc 3/8-16 Flg	12	107-3017	1	Spring-Compression
4	116-3860-03	1	Plate-Tilt, Seat Support	13	9266934	2	Screw-HWH 5/16 X 1/2 Tf
5	3230-23	11	Bolt-Carriage 5/16-18 X 3/4 Short Neck	14	126-6574	1	Decal, Lazer Model
6	104-8300	18	Nut-Nyloc 5/16-18 Flg	15	116-1297	2	Screw-Shoulder
7	116-3859-03	1	Plate-Frame, Seat	16	116-0070	1	Rod-Prop
8	26-4840	4	Spacer-Pin, Mounting	17	3256-23	1	Washer-5/16 SAE
9	116-2130-03	1	Panel-Front, Seat Mount	18	114-4465	1	Decal-Service Aid

Seat Assembly (cont.)

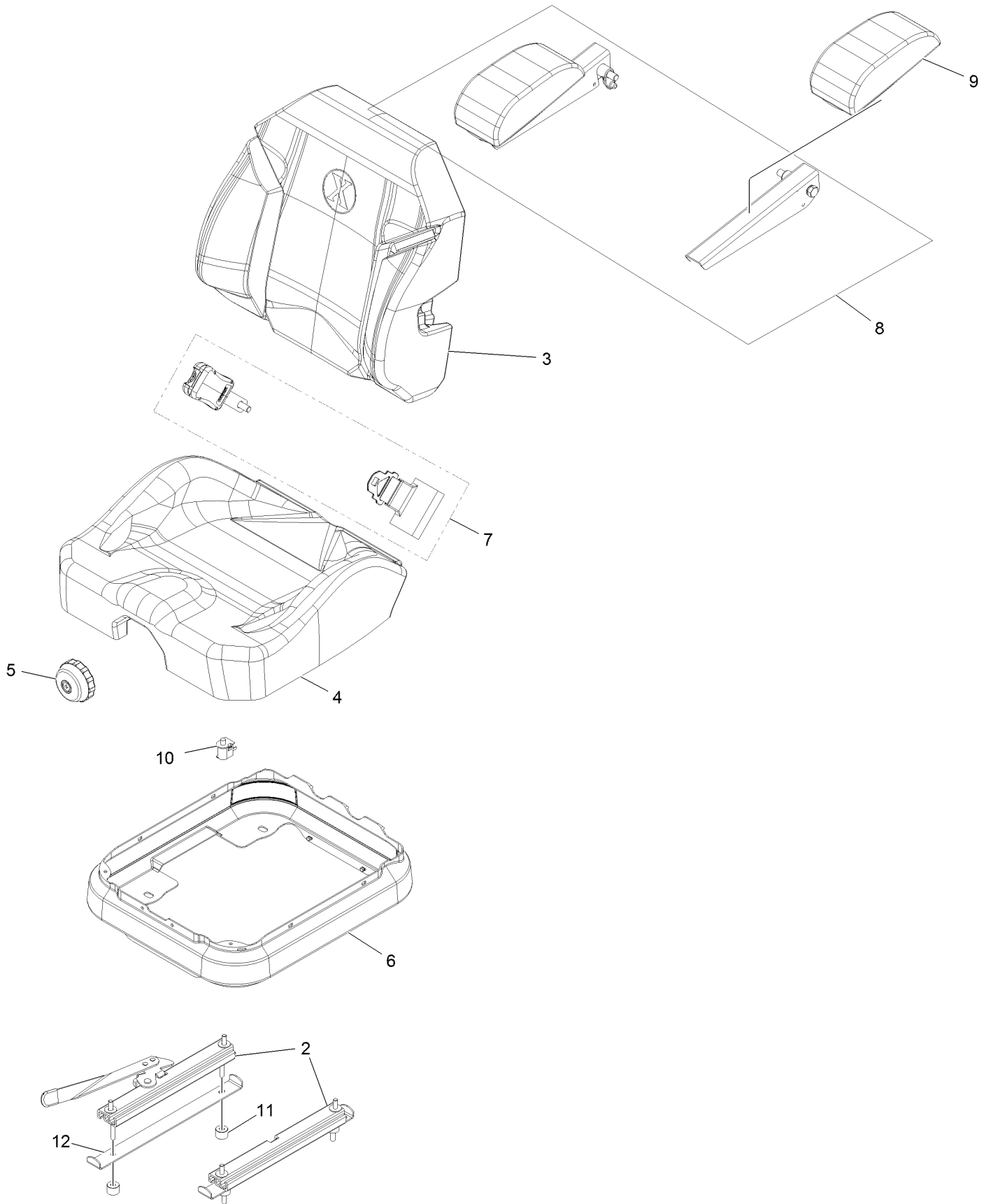

Seat Assembly (cont.) (continued)

<i>Ref.</i>	<i>Part Number</i>	<i>Qty.</i>	<i>Description</i>	<i>Ref.</i>	<i>Part Number</i>	<i>Qty.</i>	<i>Description</i>
2	116-8910	1	Seat Track Set	7	126-2061	1	Seat Belt Service Kit
3	116-8908	1	Cover-Back 311463Vn500	8	116-8906	1	Kit-Arm Rest Set
4	116-8909	1	Cover-Cushion 311464Vn500	9	116-8905	1	Kit-Arm Rest Pads
5	116-8911	1	Knob-Adjuster	10	82-2190	1	Switch
6	116-5659	1	Cover-Suspension Bellows	11	116-9329	4	Spacer
				12	126-9918-03	2	Stop, Seat ●

● Used on Diesel models only

Fuel Assembly

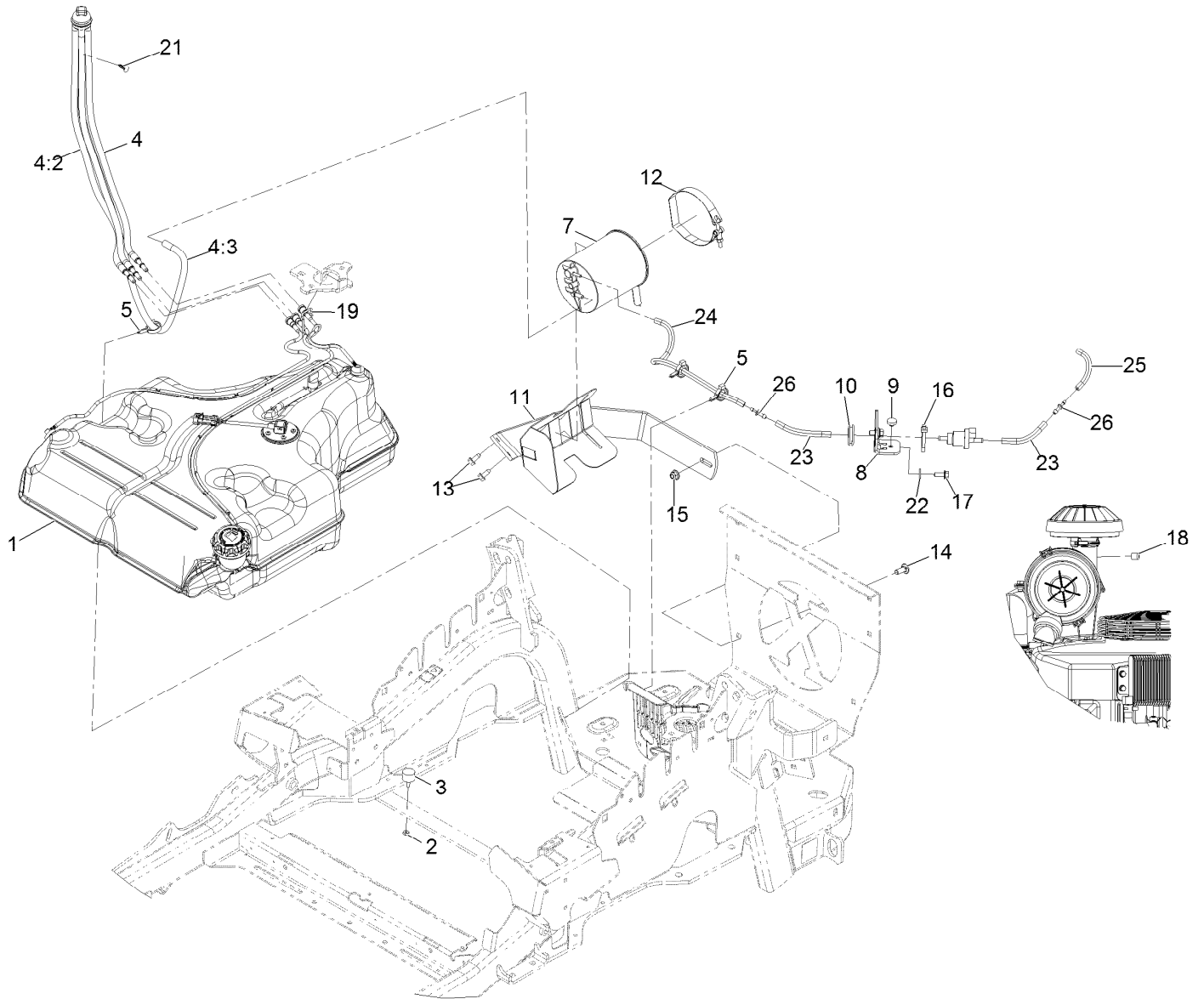

Fuel Assembly (continued)

<i>Ref.</i>	<i>Part Number</i>	<i>Qty.</i>	<i>Description</i>	<i>Ref.</i>	<i>Part Number</i>	<i>Qty.</i>	<i>Description</i>
1	135-0643	1	Fuel Tank ASM	14	3231-22	1	Bolt-Carriage 3/8-16 X 1
2	3218-1	2	Nut-Jam 1/4-20	15	104-8301	1	Nut-Nyloc 3/8-16 Flg
3	116-6380	2	Bumper-Rubber (W/ Stud)	16	1-303335	1	Tie-Cable 7 15/16 (Large)
4	127-0583	1	Fuel Manifold Vent ASM	17	95-4184	2	Screw-HH M8-1.25 X 20Mm
4:2	109-0302	3	Hose-Fuel Line 24"	18	116-4464	1	Plug-Port
4:3	108-5376	1	Hose-Fuel	19	116-6005	1	Retainer-Line, Vapor
5	105-1853	2	Clamp-Hose	21	125-8067	1	Plug-Plastic
7	116-1442	1	Canister-Carbon, 1200Cc	22	1-303334	2	Washer-Spring Disc 5/16
8	135-0350	1	Bracket-Valve Mount	23	109-0650	2	Hose-Fuel
9	1-513658	1	Bumper	24	119-6074	1	Hose-Fuel
10	1-543286	1	Grommet	25	68-3632	1	Hose-Fuel
11	116-1433-03	1	Mount-Canister	26	121-2573	2	Fitting-Straight
12	116-2228	1	Clamp-T-Bolt				
13	32144-70	2	Screw-HWH 5/16-18 X 3/4 Tf				

Fuel Tank Assembly

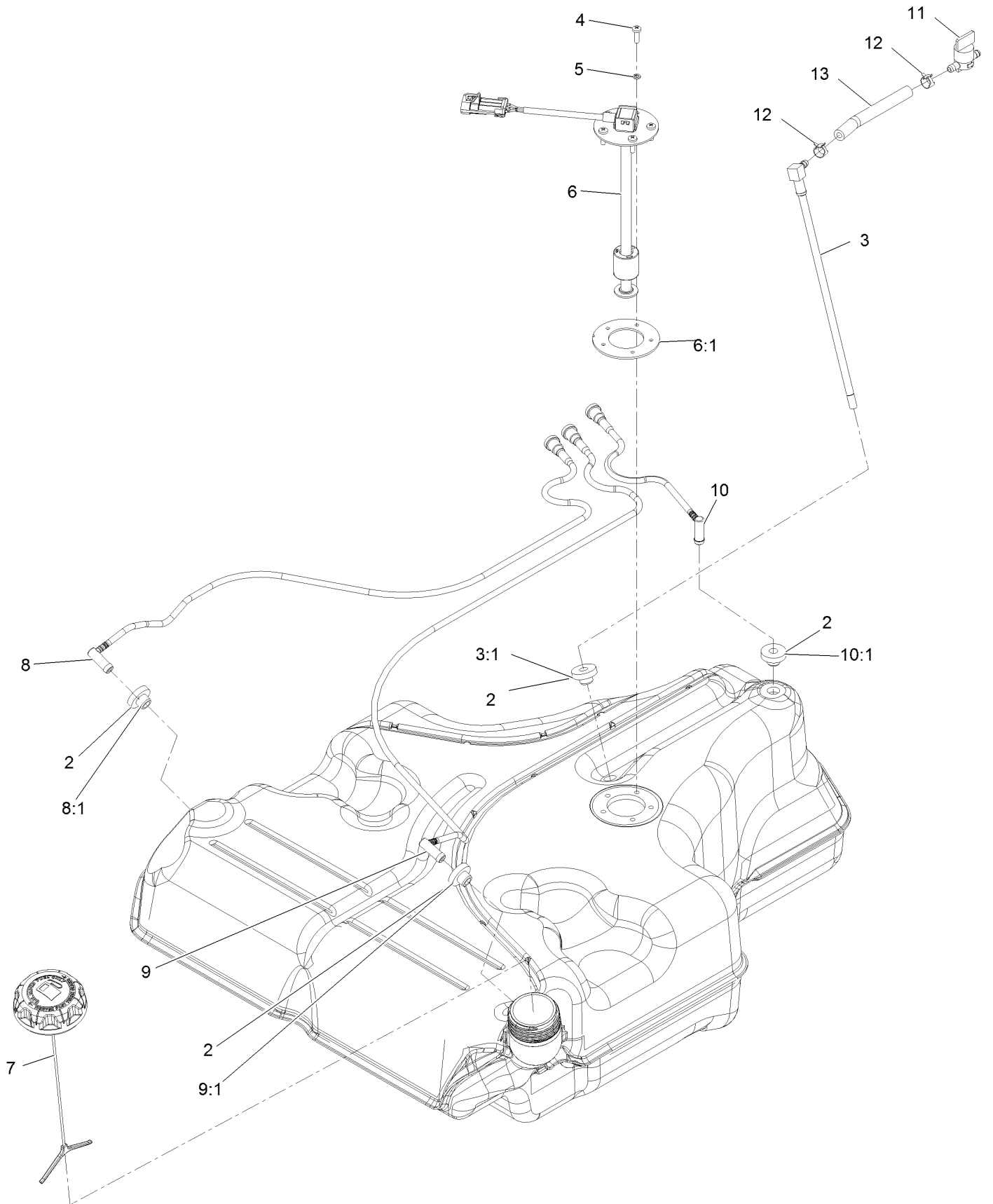

Fuel Tank Assembly (continued)

<i>Ref.</i>	<i>Part Number</i>	<i>Qty.</i>	<i>Description</i>	<i>Ref.</i>	<i>Part Number</i>	<i>Qty.</i>	<i>Description</i>
2	46-6560	4	Bushing	8:1	46-6560	1	Bushing
3	116-2459	1	Fuel Line Kit (With Grommet)	9	116-2461	1	LH Vent Line Kit (With Grommet)
3:1	46-6560	1	Bushing	9:1	46-6560	1	Bushing
4	3290-500	5	Screw-PPH	10	116-2462	1	Rear Vent Line Kit (With Grommet)
5	3253-17	5	Washer-Lock	10:1	46-6560	1	Bushing
6	126-3913	1	Float-Sender, Fuel	11	1-603770	1	Valve-Fuel
6:1	126-3950	1	Gasket-Sender	12	2412-98	2	Clamp-Hose
7	126-1789	1	Cap-Fuel, Ratcheting	13	109-0650	1	Hose-Fuel
8	116-2460	1	RH Vent Line Kit (With Grommet)				

Engine Assembly (continued)

<i>Ref.</i>	<i>Part Number</i>	<i>Qty.</i>	<i>Description</i>	<i>Ref.</i>	<i>Part Number</i>	<i>Qty.</i>	<i>Description</i>
1		1	Engine-Kawasaki, Fx801V-S04-R ▲◆	9:1	353-508	1	Plug-W/O-Ring ●
1:1		1	Kawasaki 49065-2078 Engine Oil Filter ▲◆	9:1:1	237-42	1	O-Ring
1:2		1	Kawasaki 11013-7044 Engine Air Filter ▲◆	10	98-5975	4	Washer-Spring Disc 3/8
1:3		1	Kawasaki 11013-7045 Safety Filter ▲◆	12	116-2612-01	1	Clutch-Anchor
3	116-1620	1	Clutch Kit	13	323-7	4	Screw-HH 3/8-16 X 1 1/4
4	109-6919	1	Washer-Clutch	14	104-8301	1	Nut-Nyloc 3/8-16 Flg
5	1-603610	2	Washer-Spring Disc 7/16	15	1-303334	3	Washer-Spring Disc 5/16
6	109-9761	1	Screw-HH 7/16-20 X 1 1/2 W/Loctite □	16	94-2413	2	Nut-U
7	3231-22	1	Bolt-Carriage 3/8-16 X 1	17	3234-5	2	Screw-HH Flg 5/16-18 X 3/4
8	33114-020	1	Screw-HH M8-1.25 X 20Mm	18	116-1712	1	Muffler
9	116-4924	1	Asm-Hose Oil Drain W/Plug ■	19	116-0203	1	Bracket-Muffler
				20	109-0296	1	Hose-Fuel Line 15"
				21	2412-98	2	Clamp-Hose
				22	95-4184	2	Screw-HHF
				23	105-1853	1	Clamp-Hose

● Torque to 24-26 ft-lb

▲ Not serviced separately

□ Use Pro-Lock, Nut Type (P/N 1-840022, .5ml tube) on threads.

■ Torque to 23-29 ft-lb

◆ Obtain parts from www.kawpowerepc.com

Hydraulic Assembly

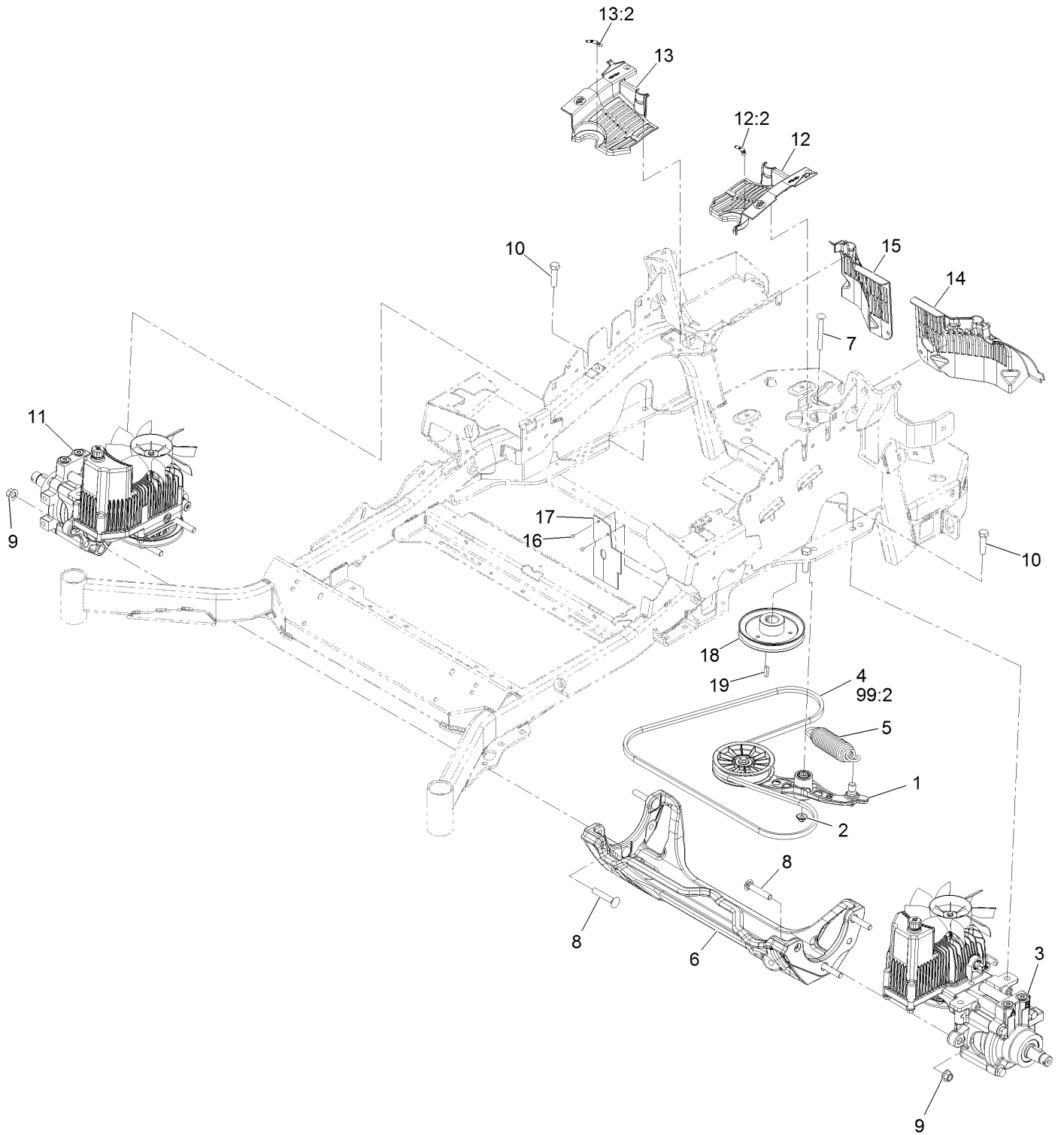

Hydraulic Assembly (continued)

<i>Ref.</i>	<i>Part Number</i>	<i>Qty.</i>	<i>Description</i>	<i>Ref.</i>	<i>Part Number</i>	<i>Qty.</i>	<i>Description</i>
1	116-1255	1	Pump Idler ASM	13	116-0171	1	RH Hydro Guard ASM
2	109-6658	1	Nut-Nyloc 3/8-16 Flg	13:2	116-8726	1	Decal-Oil, Hydro
3	126-1325	1	LH Hydro ASM (16Cc W/ Shock)	14	109-9057	1	Guard-Hydro, Rear (LH)
4	109-3388	1	Belt	15	109-9058	1	Guard-Hydro, Rear (RH)
5	116-6317	1	Spring-Extension	16	1-803035	2	Rivet 3/16 X 1/4
6	116-7558	1	Cradle-Hydro	17	116-2362	1	Deflector-Air Flow
7	116-1502	1	Bolt-Carriage Shoulder 3/8-16 X 3 1/2	18	109-9905	1	Sheave
8	126-0095	6	Screw-CARR	19	1-807259	1	Key-Machine 1/4 X 1/4 X 1
9	99-5107	6	Nut-Lock 1/2-13	99	109-9828	1	Bottle-Oil, 32Oz Hydraulic ●
10	325-8	4	Screw-HH 1/2-13 X 1 1/4	99	116-0164	1	Filter-Hydro ●
11	126-1326	1	RH Hydro ASM (16Cc W/ Shock)	99	116-1218	1	Bottle,Oil 1 Gallon Hydraulic ●
12	116-0170	1	LH Hydro Guard ASM	99	116-3270	1	Kit, Hydro Service ●
12:2	116-8726	1	Decal-Oil, Hydro	99:1	109-9828	4	Bottle-Oil, 32Oz Hydraulic ●
				99:2	109-3388	1	Belt
				99:3	116-0164	2	Filter-Hydro ●

● Not illustrated

LH Hydro Assembly No. 126-1325

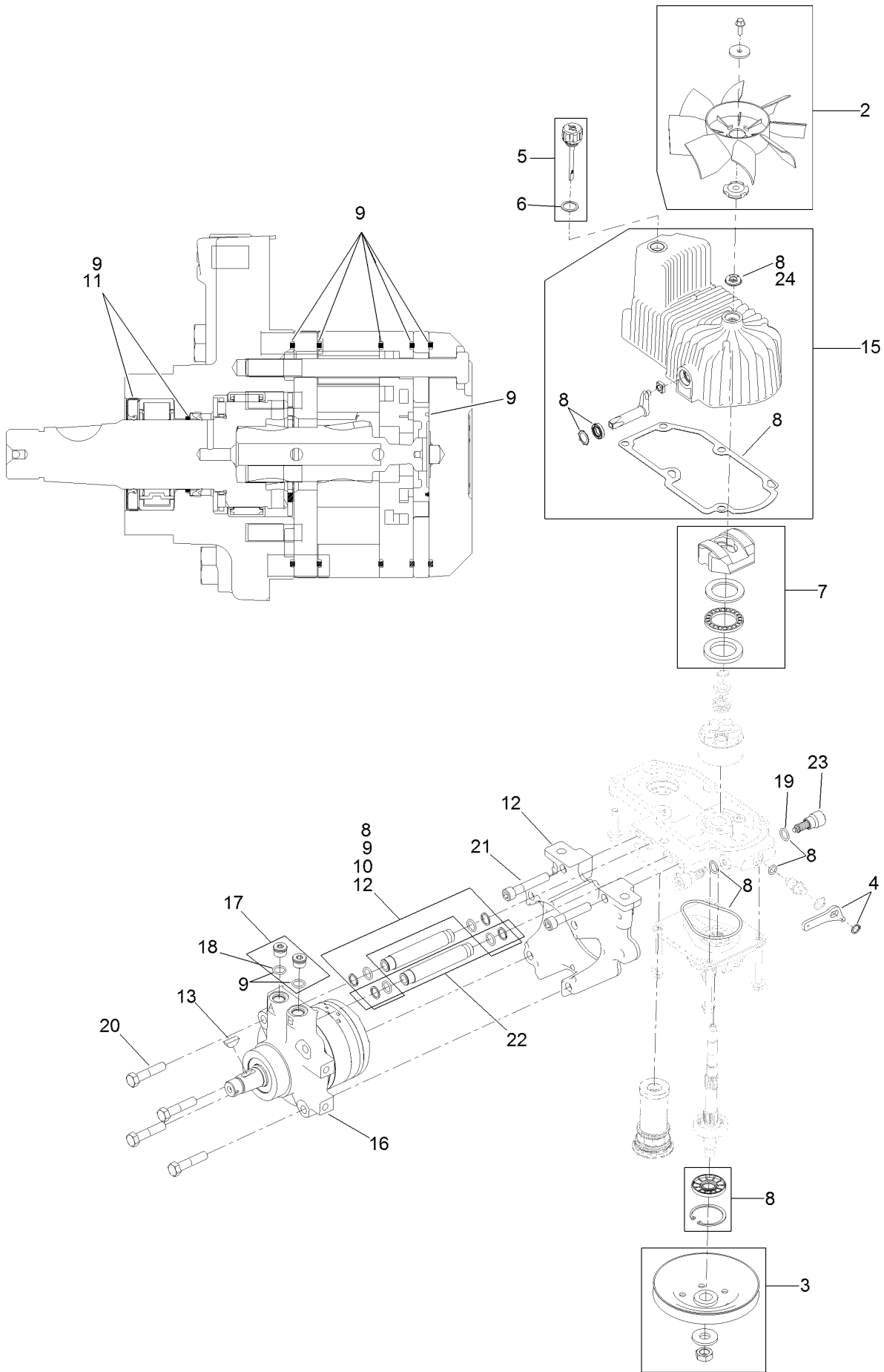

LH Hydro Assembly No. 126-1325 (continued)

<i>Ref.</i>	<i>Part Number</i>	<i>Qty.</i>	<i>Description</i>	<i>Ref.</i>	<i>Part Number</i>	<i>Qty.</i>	<i>Description</i>
2	116-0233	1	Fan Kit	15	116-3287	1	Housing-LH
3	116-0234	1	Pulley Kit	16	116-8917	1	Motor-Hydraulic, LH 280Cc
4	116-0235	1	Handle-Bypass Valve, Hydro	17	116-7901	1	Magnetic Plugs Service Kit
5	116-0236	1	Dipstick-Hydro W/Gasket	18	76-1900	2	O-Ring
6	116-0237	1	Gasket-Dipstick, Hydro	19	116-8662	2	O-Ring-Check Valve
7	116-1367	1	Swash Block Kit	20	116-8974	4	Screw HH
8	116-1368	1	Pump Seal Kit	21	116-8975	2	Screw-HSH
9	116-1369	1	Motor Seal Kit	22	116-9922	2	Hydraulic Tube Kit
10	116-1370	1	Tube Seal Kit	23	126-7467	2	Shock Valve, 16Cc Hydro
11	116-1371	1	Output Shaft Seal Kit	24	126-7711	1	Seal-Fan Drive
12	116-5469	1	Nose Cup-Uht	99	116-1373	1	Flow Test Kit ●
13	3257-42	1	Key-Woodruff	99	116-4245	1	Puller-Pulley

● Not illustrated

RH Hydro Assembly No. 126-1326

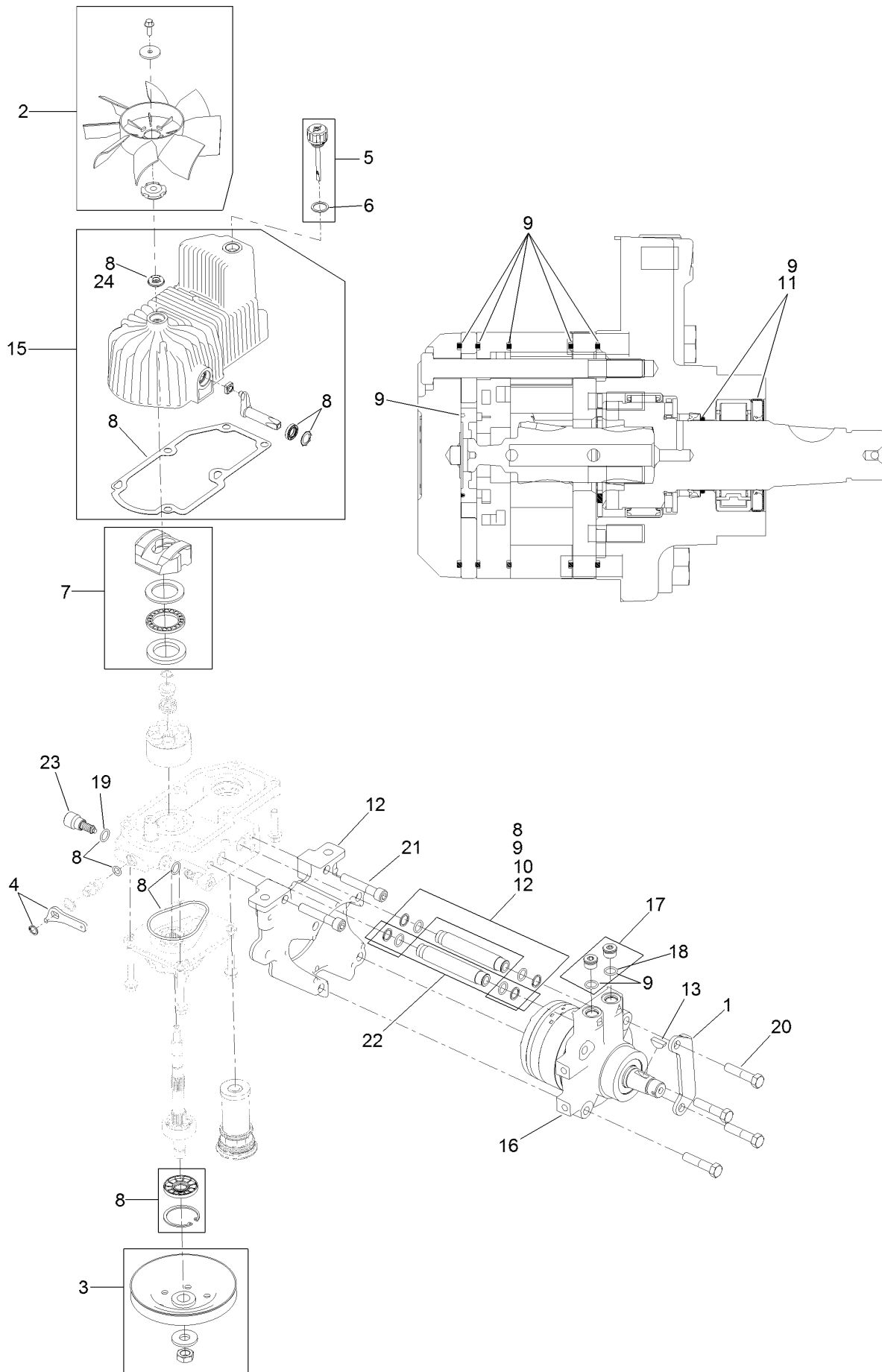

RH Hydro Assembly No. 126-1326 (continued)

<i>Ref.</i>	<i>Part Number</i>	<i>Qty.</i>	<i>Description</i>	<i>Ref.</i>	<i>Part Number</i>	<i>Qty.</i>	<i>Description</i>
1	116-9063	1	Mount-Shoe, Horse	13	3257-42	1	Key-Woodruff
2	116-0233	1	Fan Kit	15	116-3288	1	Housing-RH
3	116-0234	1	Pulley Kit	16	116-8918	1	Motor-Hydraulic, RH 280Cc
4	116-0235	1	Handle-Bypass Valve, Hydro	17	116-7901	1	Magnetic Plugs Service Kit
5	116-0236	1	Dipstick-Hydro W/Gasket	18	76-1900	2	O-Ring
6	116-0237	1	Gasket-Dipstick, Hydro	19	116-8662	2	O-Ring-Check Valve
7	116-1367	1	Swash Block Kit	20	116-8974	4	Screw HH
8	116-1368	1	Pump Seal Kit	21	116-8975	2	Screw-HSH
9	116-1369	1	Motor Seal Kit	22	116-9922	2	Hydraulic Tube Kit
10	116-1370	1	Tube Seal Kit	23	126-7467	2	Shock Valve, 16Cc Hydro
11	116-1371	1	Output Shaft Seal Kit	24	126-7711	1	Seal-Fan Drive
12	116-5469	1	Nose Cup-Uht	99	116-1373	1	Flow Test Kit ●
				99	116-4245	1	Puller-Pulley

● Not illustrated

Pump Idler Assembly No. 116-1255

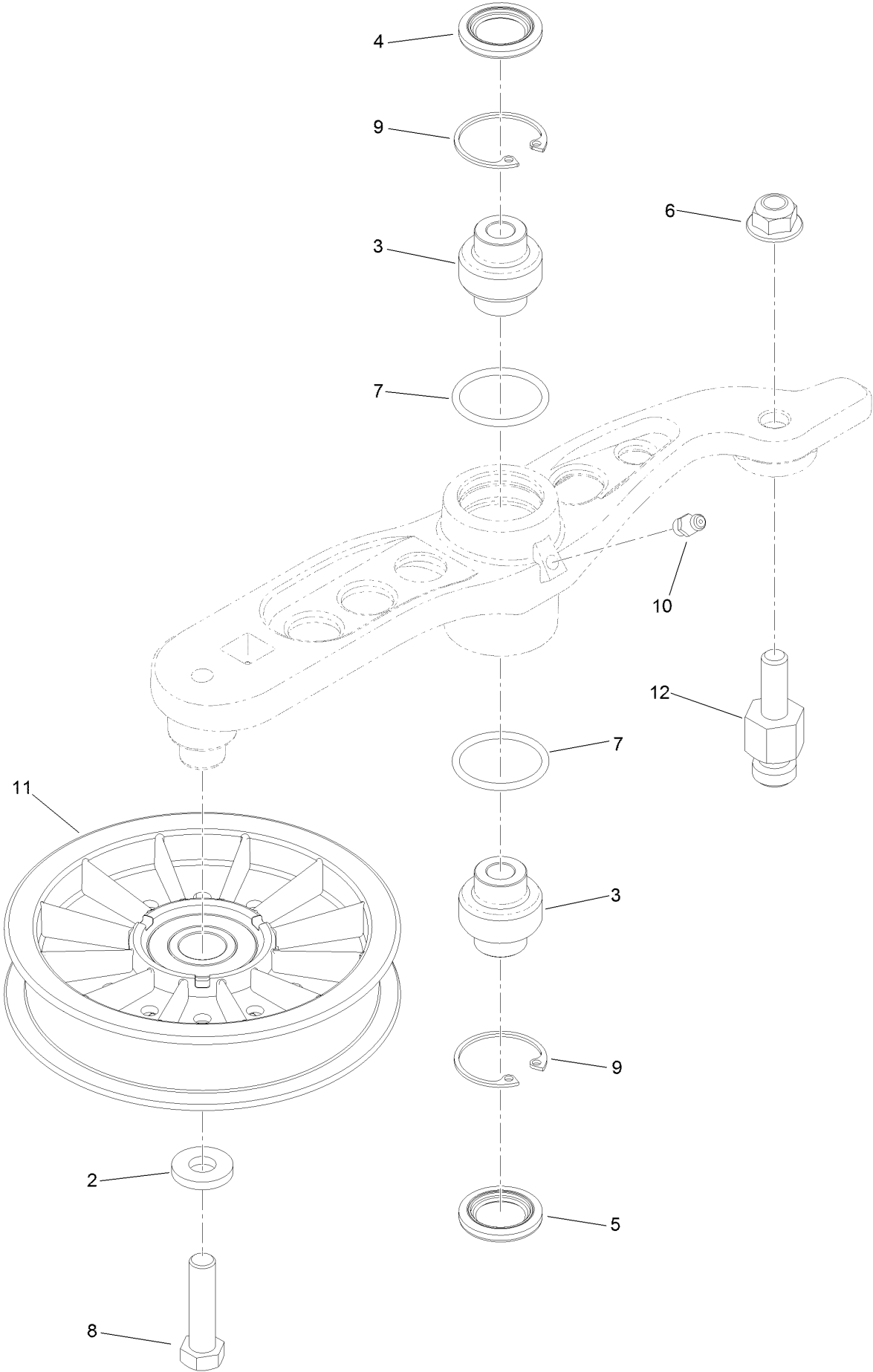

Pump Idler Assembly No. 116-1255 (continued)

<i>Ref.</i>	<i>Part Number</i>	<i>Qty.</i>	<i>Description</i>	<i>Ref.</i>	<i>Part Number</i>	<i>Qty.</i>	<i>Description</i>
2	43-0940	1	Spacer	8	323-8	1	Screw-HH
3	103-3504	2	Bearing-Spherical	9	32120-10	2	Ring-Snap
4	103-3505	1	Seal-Double Lip	10	302-19	1	Fitting-Grease
5	103-3506	1	Seal-Lip, Single	11	109-8076	1	Pulley-Idler
6	109-6658	1	Nut-Flange, NI	12	132-4724	1	Pin-Anchor, Spring
7	106-7159	2	O-Ring				

Electrical Assembly

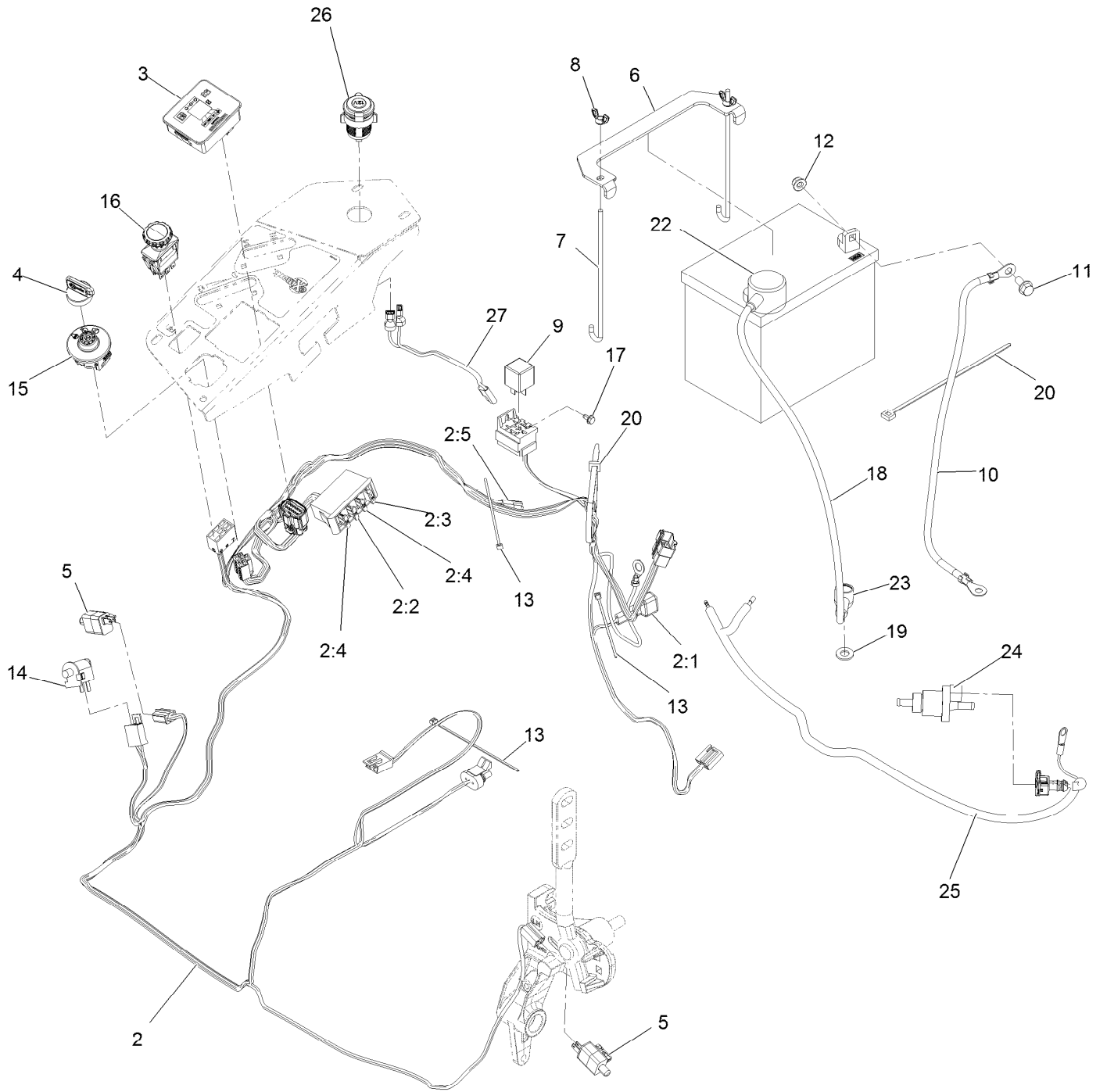

Electrical Assembly (continued)

<i>Ref.</i>	<i>Part Number</i>	<i>Qty.</i>	<i>Description</i>	<i>Ref.</i>	<i>Part Number</i>	<i>Qty.</i>	<i>Description</i>
2	116-6009	1	Harness-Wire, Main ●	12	104-8300	2	Nut-Nyloc 5/16-18 Flg
2:1	103-3895	1	Diode	13	1-303287	3	Tie-Cable 5 1/2 (Small)
2:2	218-578	1	Fuse-Blade, 10 Amp	14	82-2190	1	Switch
2:3	109355	1	Fuse-Blade, 15 Amp	15	117-2221	1	Switch-Ignition
2:4	109102	2	Fuse-Blade, 25 Amp	16	116-0124	1	Switch-PTO, 10 Amp
2:5	116-0053	1	Cap-Plug	17	104-2065	1	Screw-HWH #10-24 X 3/8
3	117-3882	1	Fuel/Hour Meter ASM	18	115-3864	1	Cable-Battery, Positive
4	1-603511	1	Key-Ignition	19	3256-24	1	Washer-3/8 SAE
4	103-2106	1	Key-Exmark Logo	20	1-303335	2	Tie-Cable 7 15/16 (Large)
5	110-6765	2	Switch	22	109-2407	1	Insulator-Battery
6	116-0042-03	1	Strap-Tie Down, Battery	23	1-543393	1	Insulator-Solenoid
7	1-633651	2	Bolt-Holddown	24	135-0331	1	Valve-Purge
8	1-543792	2	Wingnut-Nyloc 1/4-20	25	135-0400	1	Harness-Wire, Adapter
9	1-643275	1	Relay-12Vdc 40 Amp	26	109-9376	1	Receptacle-12V
10	114-1218	1	Cable-Battery, Negative	27	109-9693	1	Harness, Receptacle 12V
11	3234-5	2	Screw-HH Flg 5/16-18 X 3/4				

● Use dielectric grease on all unsealed connectors and terminals only. Do not apply in sealed connectors.

Notes:



MAXIMIZE THE PERFORMANCE OF YOUR EXMARK MACHINE.



EXMARK® PREMIUM ENGINE OIL

Exmark now offers a family of engine oil viscosities to perform well in any environment. Each viscosity has the same synthetic formulation to give you what you need in punishing conditions. We designed each grade to the highest quality, making it ideal even for diesel applications. Coupled with Exmark Premium Fuel Treatment, we have the performance products to make your machine hum.

EXMARK PREMIUM ENGINE OIL SAE 30/10W-30

- Meets zero shear requirements of a straight grade SAE 30 as well as the cold temp properties of a 10W-30.
- Most versatile oil in the industry.
- Superior corrosion protection over conventional oil - even in corrosive, humid environments.

EXMARK PREMIUM ENGINE OIL SAE 20W-50

- Perfect for your big block engine, or any application in severe service.
- Same full synthetic formulation as all other Exmark Premium viscosities.
- Also effective for use in severe service small block engines.

EXMARK PREMIUM ENGINE OIL SAE 10W-50

- Full synthetic formulation gives you peak performance. Don't settle for less.
- Wide span multi-grade combines easy starting in cold weather with maximum protection in high temperature operation.
- Reduce friction & wear over standard mineral formulations.

EXMARK PREMIUM ENGINE OIL SAE 0W-40

- The perfect choice for when the weather turns cold or unpredictable, and your Exmark UTV has to perform.
- Commercial quality for severe service.
- Advanced additive package helps prevent corrosion from long-term storage.

EXMARK PREMIUM ENGINE OIL UTV FORMULATION

- 4-cycle high-temp formulation.
- Heavier viscosity, full synthetic, perfect for your UTV.

EXMARK PREMIUM UTV EXTREME CONDITIONS GEAR OIL

- SAE 80W-90, designed to keep your UTV performing at its peak.
- Shear stable, hypoid gear lube.
- Includes a premium additive system to combat wear, oxidation, rust & corrosion.

Available from your local Exmark dealer. Find your closest dealer at exmark.com

EXMARK ACCESSORIES AND OPTIONS*

MID-MOUNT RIDING ACCESSORIES AND OPTIONS

CUSTOM RIDE SEAT SUSPENSION SYSTEM	OPERATOR CONTROLLED DISCHARGE
FULL SUSPENSION SEAT	SUN SHADE
DECK LIFT ASSIST KIT	TRASH CONTAINER
HITCH KIT	TURF STRIPER
LIGHT KIT	ULTRA VAC COLLECTION SYSTEM
12V POWER PORT	ULTRA VAC QUICK DISPOSAL SYSTEM
MICRO-MULCH SYSTEM	

OUT-FRONT RIDING ACCESSORIES AND OPTIONS

CUSTOM RIDE SEAT SUSPENSION SYSTEM	SNOW BLADE
DUAL-TAIL WHEEL	SNOWBLOWER
FLOOR PAN EXTENDER	SUN SHADE
HITCH KIT	TRASH CONTAINER
LIGHT KIT	ULTRA VAC COLLECTION SYSTEM
MICRO-MULCH SYSTEM	ULTRA VAC QUICK DISPOSAL SYSTEM
ROLL OVER PROTECTION SYSTEM (ROPS)	WEATHER CAB

WALK-BEHIND ACCESSORIES AND OPTIONS

GRASS CATCHER	TURF STRIPER
MICRO-MULCH SYSTEM	STANDON

*Some accessories and options not available for some models.

Place Model No. and Serial No.
Label Here (Included in the Literature
Pack) or Fill in Below

Model No. _____

Serial No. _____

Date Purchased _____

Engine Model No. and Spec. No. _____

Engine Serial No. (E/No) _____

© 2017 Exmark Mfg. Co., Inc.
Industrial Park Box 808
Beatrice, NE 68310
All Rights Reserved

Part No. 4503-348 Rev. A
(402) 223-6375
Fax (402) 223-5489
Printed in the USA.

