

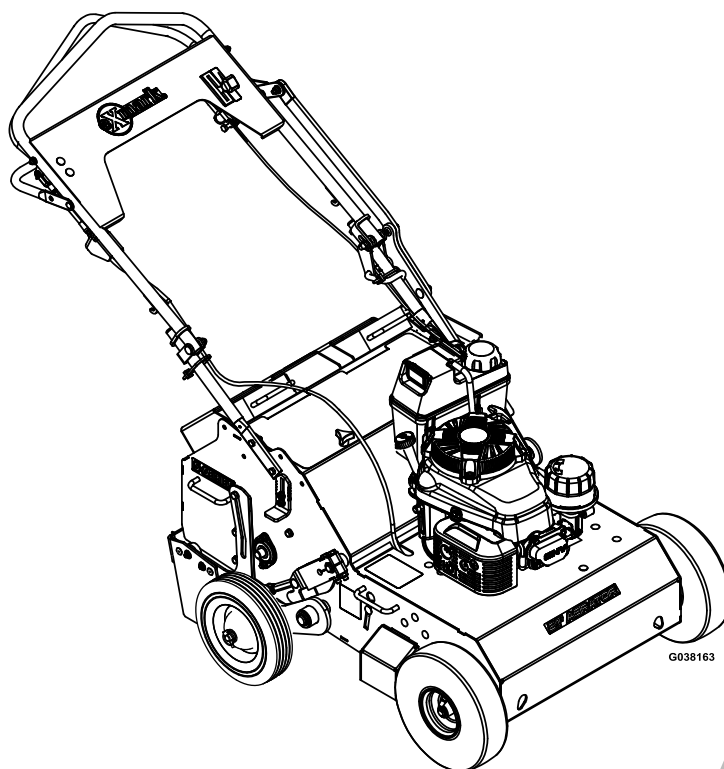

21 INCH WALK-BEHIND AERATOR

Model No. ARS180CKA21000—Serial No. 40000000 and Up

Picture below may not reflect actual product.



Parts Manual

Part No. 4503-222 Rev. A

Ordering Replacement Parts

To order replacement parts, please supply the part number, the quantity, and the description of each part desired.

Understanding Reference Numbers

Each identified part in an illustration has a reference number. The reference number for a part also appears in the parts list, along with other information about the part.

This catalog uses two special reference number formats, one to indicate parts in a service assembly and another to indicate the quantity of a given part in an illustration.

Service Assembly Reference Numbers

Parts in service assemblies have reference numbers in the form a:b. The a represents the reference number of the entire service assembly and the b represents a sequential number unique to each part within the service assembly.

For example, a wheel assembly might be identified by reference number 6, the tire by 6:1, the valve by 6:2, and the wheel by 6:3. When you order the assembly identified by reference number 6, you receive all parts identified by reference numbers 6:1, 6:2, and 6:3. However, you may also order any part individually. Reference numbers of this type appear in illustration and in parts lists.

Reference Numbers Indicating Quantity

In an illustration, if a reference number indicates more than one part, the reference number has the form nX y. The n represents the quantity of the part, the X is the multiplication symbol, and the y represents the reference number.

For example, in an illustration, the reference number 2X 37 means that two of the parts identified by reference number 37 are indicated.

List of Abbreviations

AR: as required	HLH: hex lag head	PTH: phillips truss head
ASM: assembly	HOC: height-of-cut	PTO: power-take-off
BBC: blade brake control	HP: high pressure	RH: right hand
BHTF: button head thread forming	HSBH: hex socket button head	ROPS: roll-over protection system
CARR: carriage	HSFH: hex socket flat head	RRB: rear roller brush
CCW: counter clockwise	HSH: hex socket head	SFH: slotted fillister head
CW: clockwise	HWH: hex washer head	SHH: slotted hex head
DEG: degrees	HWHTF: hex washer head thread forming	SHWH: slotted hex washer head
DPA: Dual Point Adjustment	HYD: hydraulic	SPH: slotted pan head
ECM: electronic control module	LH: left hand	SQH: square head
EXT: external	LP: low pressure	SRH: slotted round head
FH: flat head	LPG: Liquefied Petroleum Gas	STD: standard
GA: gauge	NI: nylon insert	TAP: self tapping
HD: heavy-duty	NPTF: national pipe thread fine	TTH: torx truss head
HF: hex flange	PFH: phillips flat head	
HH: hex head	PPH: phillips pan head	
HHF: hex head flange	PPHTF: phillips pan head thread forming	
HHFTF: hex head flange thread forming	PRH: phillips round head	
HJ: hex jam		

Touch Up Paint

Exmark black touch up spray paint – gloss black.

Exmark red touch up paint (spray paint – P/N 1-850337 - .6 oz liquid bottle – P/N 103-9140).



If your Exmark dealer does not have the Exmark part in stock, Exmark will get the parts to the dealer the next business day or the part will be FREE Guaranteed!! (Some restrictions apply. See your participating Exmark Dealer for details.)

Contents

Frame Assembly..... 4
Frame Assembly W/Decals 6
Engine Assembly 8
Drive Assembly..... 10
Handle Assembly 12
Height Linkage Assembly 14
Tine Wheel Drive Assembly 16

Frame Assembly

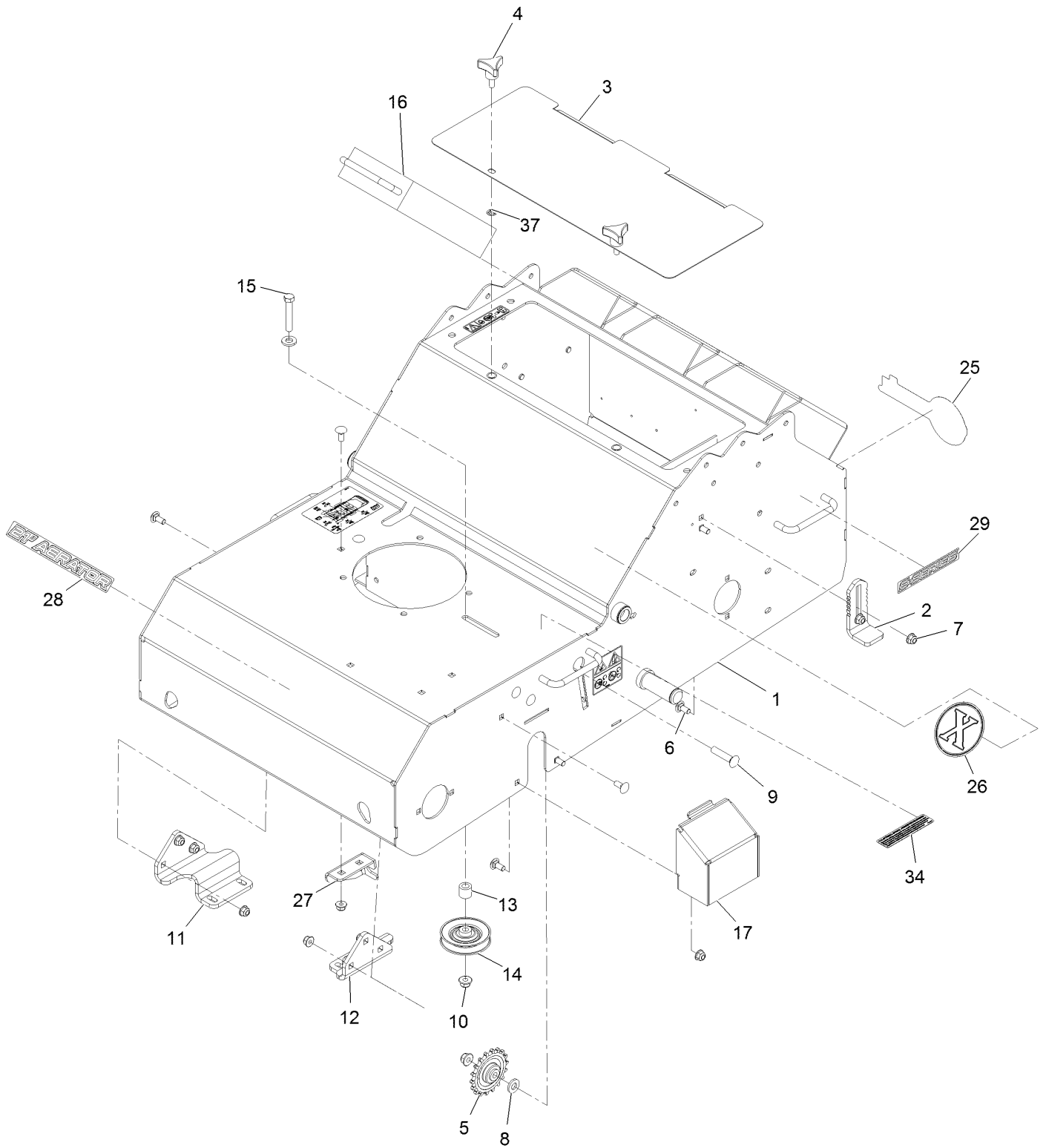

Frame Assembly (continued)

<i>Ref.</i>	<i>Part Number</i>	<i>Qty.</i>	<i>Description</i>	<i>Ref.</i>	<i>Part Number</i>	<i>Qty.</i>	<i>Description</i>
1	126-5102	1	Frame ASM	13	121-6087	1	Bushing-Idler
2	116-9886	2	Stop-Depth	14	62-4530	1	Pulley
3	126-0974-01	1	Cover-Access	15	323-11	1	Screw-HH 3/8-16 X 2 1/4
4	109-3351	2	Knob-5/16X3/4 3-Prong	16	121-6080	1	Weight-Aerator
5	121-4915	2	Sprocket-Idler	17	121-1981-01	2	Cover-Transaxle
6	3230-1	16	Bolt-Carriage 5/16-18 X 3/4	25	126-7196	1	Decal, Exmark Logo
7	104-8300	16	Nut-Nyloc 5/16-18 Flg	26	126-7194	1	Decal-X-Logo
8	87-7480	3	Washer	27	121-6056	1	Bracket-Mounting, Cable
9	3231-29	2	Bolt-Carriage 3/8-16 X 1 3/4	28	126-7032	1	Decal-Aerator 21 Logo
10	104-8301	3	Nut-Nyloc 3/8-16 Flg	29	126-6998	2	Decal-S-Series
11	121-4948-03	1	Bracket-Mount Axle, RH	34	117-2718	1	Decal-Arrester, Spark
12	121-4949-03	1	Bracket-Mount Axle, LH	37	117-2749	2	Nut-Push

Frame Assembly W/Decals

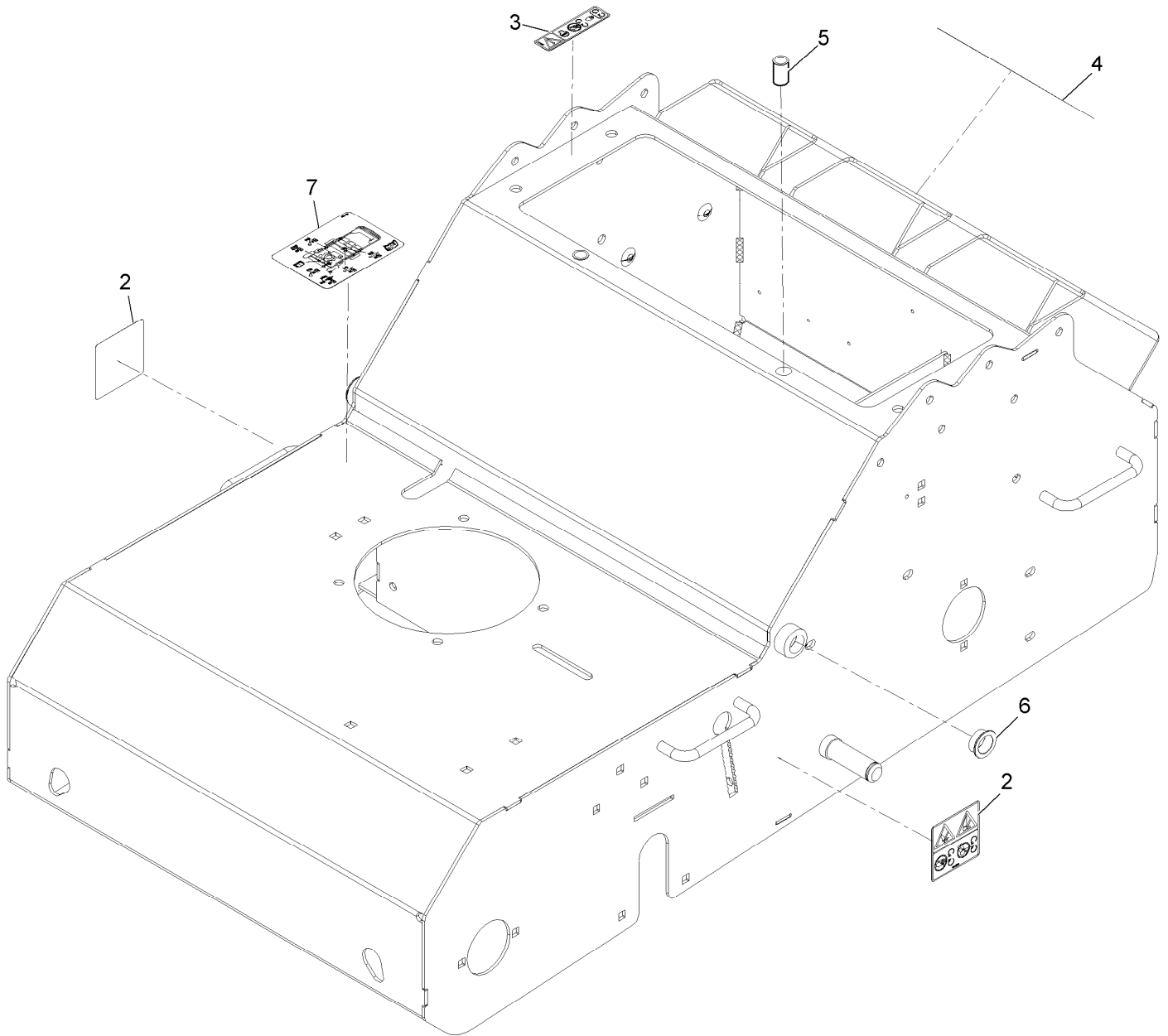

Frame Assembly W/Decals (continued)

<i>Ref.</i>	<i>Part Number</i>	<i>Qty.</i>	<i>Description</i>	<i>Ref.</i>	<i>Part Number</i>	<i>Qty.</i>	<i>Description</i>
2	121-6150	2	Decal-Warning	5	32148-7	2	Nut-Insert
3	119-0217	1	Decal-Danger	6	108519	2	Bushing-Bronze
4	126-0651	1	Decal-Warning	7	126-1209	1	Decal-Service Aid

Engine Assembly

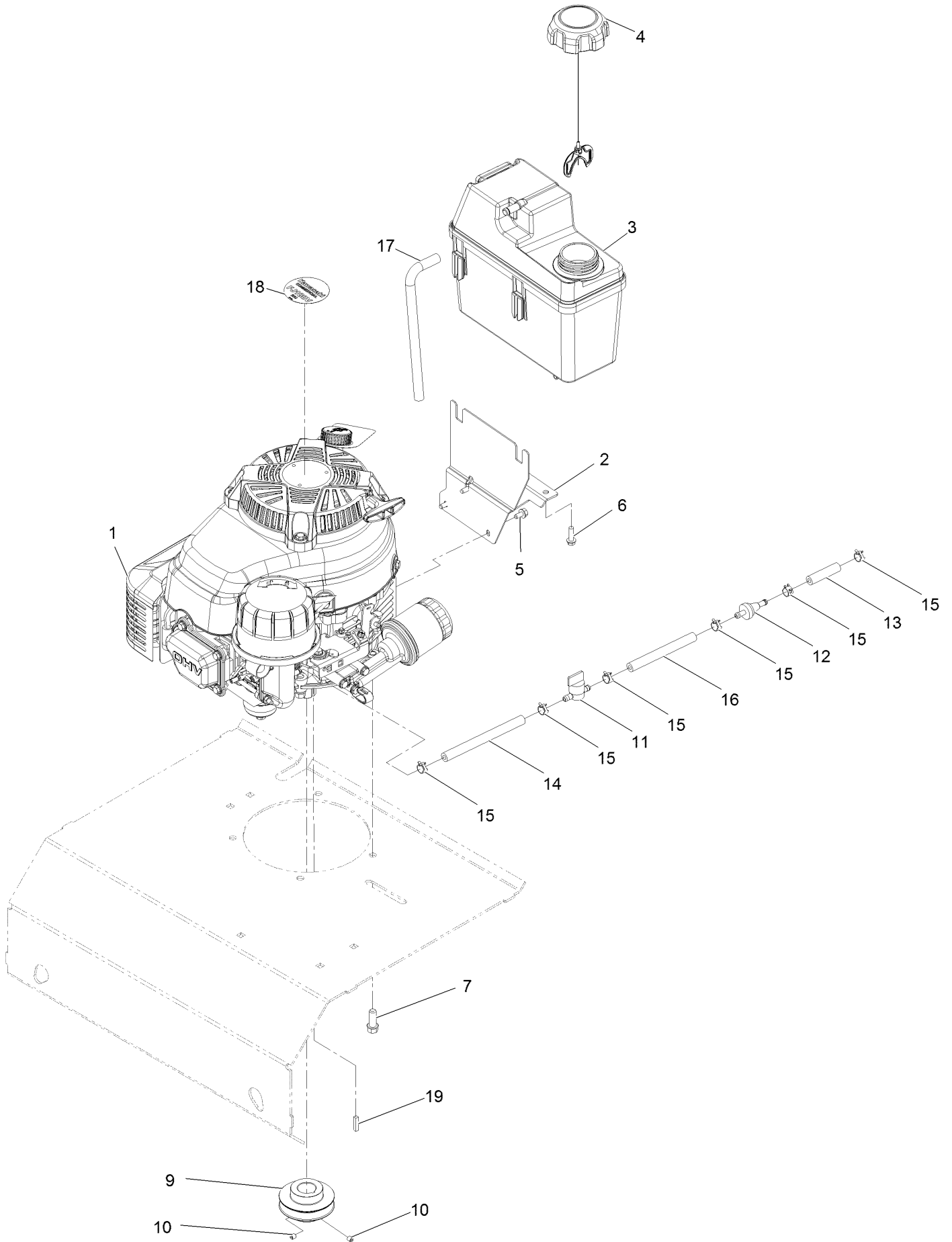

Engine Assembly (continued)

<i>Ref.</i>	<i>Part Number</i>	<i>Qty.</i>	<i>Description</i>	<i>Ref.</i>	<i>Part Number</i>	<i>Qty.</i>	<i>Description</i>
1		1	Engine-Kawasaki, Fj180V-Bm02-M ●■	10	3245-35	2	Screw-Set HSH 1/4-28 X 1/4 ▲
2	115-0954-03	1	Mount-Tank	11	1-603770	1	Valve-Fuel
3	114-0280	1	Tank-Fuel	12	71-9280	1	Filter-Fuel
4	115-7788	1	Cap-Fuel	13	99-9415	1	Hose-Fuel
5	104-2628	3	Screw-HWH M6-1 X 12Mm Tf	14	109-0300	1	Hose-Fuel
6	46-8091	2	Screw-HWH 1/4-10 X .82 Plastite	15	2412-98	6	Clamp-Hose
7	95-1726	4	Screw-HWH 3/8-16 X 1 Taptite	16	109-0650	1	Hose-Fuel
9	126-0839	1	Pulley-Driver	17	115-0962	1	Hose-Vent, Canister
				18	109-6528	1	Decal-Recoil
				19	6366	1	Key-3/16 X 3/16 X 7/8

● Not serviced separately

▲ Use Pro-Lock, Nut Type (P/N 1-840022, .5ml tube) on threads.

■ Obtain parts from www.kawpowerepc.com

Drive Assembly

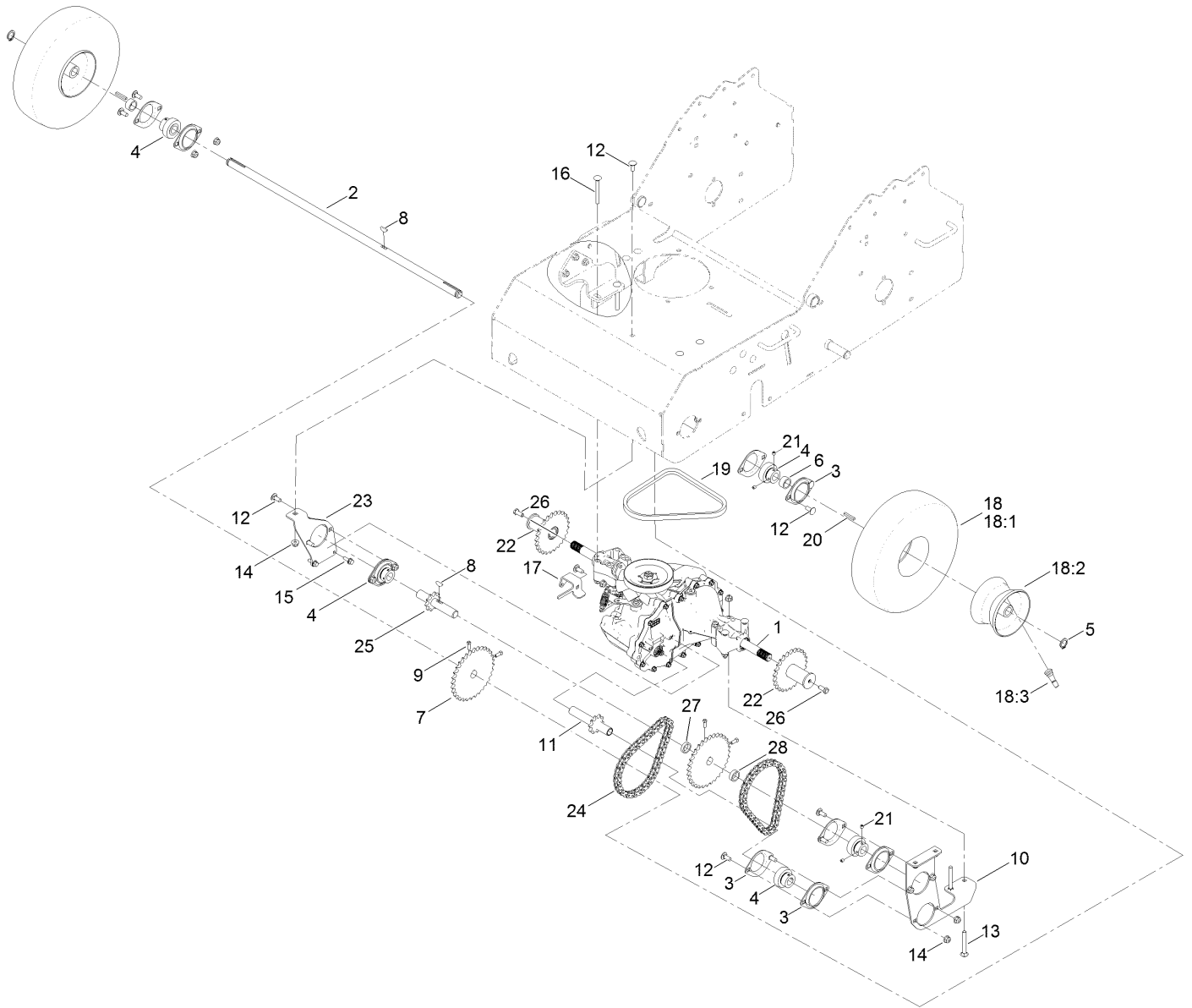

Drive Assembly (continued)

<i>Ref.</i>	<i>Part Number</i>	<i>Qty.</i>	<i>Description</i>	<i>Ref.</i>	<i>Part Number</i>	<i>Qty.</i>	<i>Description</i>
1	121-4899	1	Transaxle ASM	17	121-6067	1	Angle-Control
2	121-4927	1	Shaft-Wheel	18	120-3550	2	Wheel ASM
3	105-9714	10	Flange-Bearing	18:1	121-6081	1	Tire
4	120-9350	5	Bearing-Lock, Collar	18:2	121-6082	1	Wheel-Rim
5	32120-93	2	Ring-Retaining	18:3	5108	1	Valve
6	121-4931	2	Spacer-Wheel	19	121-1999	1	Belt-Drive
7	121-4934	2	Sprocket	20	92-0049	2	Key-Square
8	3257-5	2	Key-Woodruff	21	3245-35	10	Screw-Set, HSH ●
9	3241-5	4	Screw-Set ●	22	116-9860	2	Sprocket
10	121-4936-03	1	Plate-Bearing	23	121-4932-03	1	Bracket-Support, Shaft
11	121-4937	1	Shaft-Output	24	121-6105	2	Chain-Drive Wheel
12	3230-23	14	Screw-CARR	25	121-6108	1	Shaft-Jack
13	3230-8	2	Screw-CARR	26	3235-6	2	Screw-HH ●
14	104-8300	20	Nut-Flange, NI	27	105-3828	1	Spacer
15	3234-4	2	Screw-HHF	28	94-9524	1	Spacer-Control
16	3230-9	4	Screw-CARR				

● Use Pro-Lock, Nut Type (P/N 1-840022, .5ml tube) on threads.

Handle Assembly

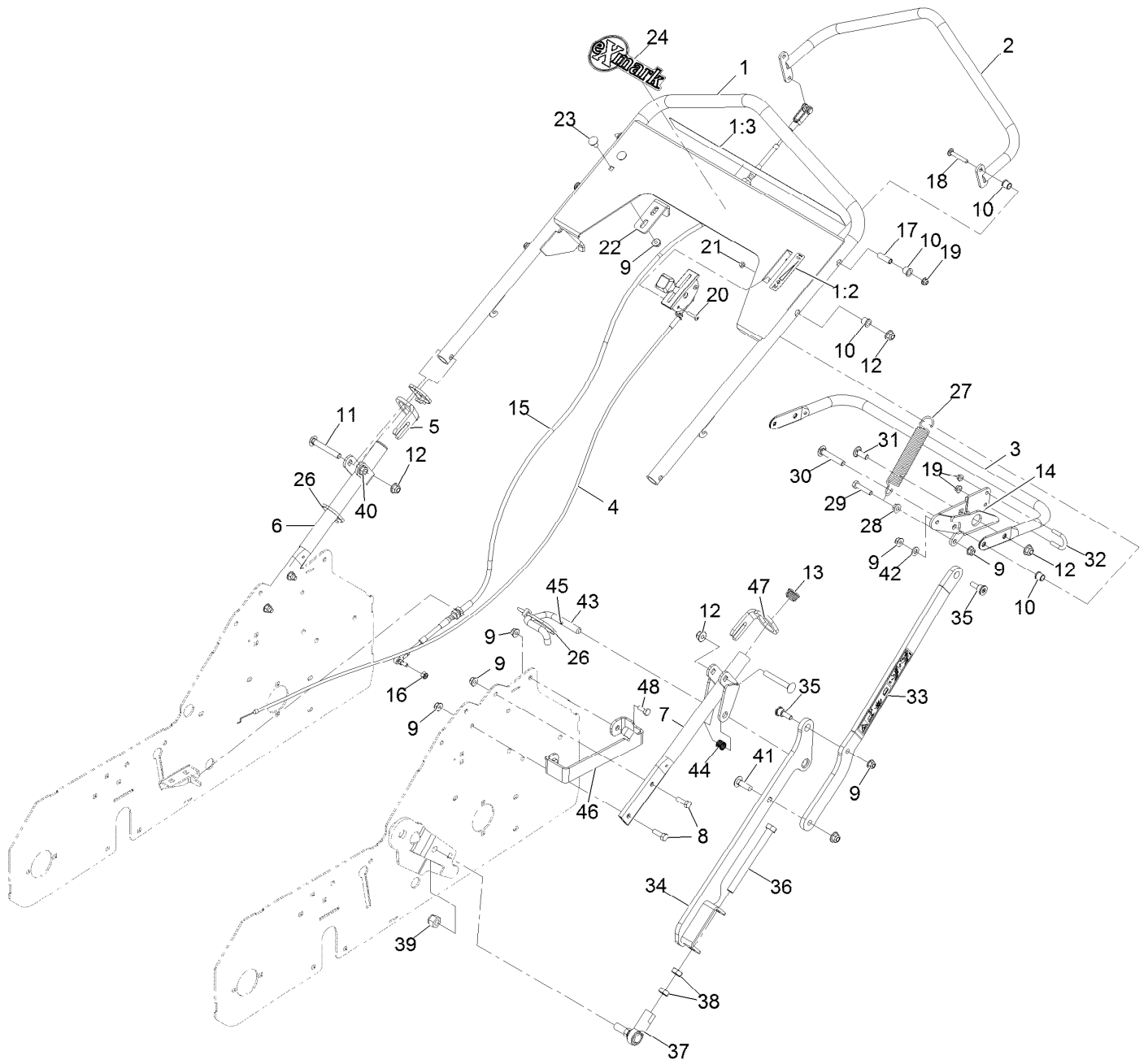

Handle Assembly (continued)

<i>Ref.</i>	<i>Part Number</i>	<i>Qty.</i>	<i>Description</i>	<i>Ref.</i>	<i>Part Number</i>	<i>Qty.</i>	<i>Description</i>
1	126-0639	1	Handle ASM	24	126-7196	1	Decal, Exmark Logo
1:2	121-6151	1	Decal-Throttle, Choke	26	3290-378	3	Tie-Cable
1:3	116-8699	1	Decal-Aerator Control Panel	27	106-2177	1	Spring-Extension
2	121-6053-03	1	Tube-Control	28	32128-20	1	Nut-Whizlock 5/16-18
3	116-9873-03	1	Tube-Handle Lift	29	322-7	1	Screw-HH 5/16-18 X 1 1/2
4	116-9898	1	Control-Throttle	30	3231-40	1	Bolt-Carriage 3/8-16 X 2 1/4
5	126-6287	1	Ring, Handle Lock	31	3231-22	1	Bolt-Carriage 3/8-16 X 1
6	121-1893-03	1	Handle-Lower	32	01-170-0040	1	U-Bolt
7	116-9883-03	1	Asm-Lower Handle	33	126-6512	1	ASM, Upper Link W/ Decal
8	322-5	4	Screw-HH 5/16-18 X 1	34	126-5470-03	1	Arm-Lower
9	104-8300	11	Nut-Nyloc 5/16-18 Flg	35	119-4073	2	Bolt-Shoulder, Groomer
10	103-9928	8	Bearing	36	126-5473	1	Screw-HH 1/2-20 X 5 1/2
11	126-7090	2	Screw-CARR	37	86-1550	1	End-Rod, RH Thread
12	104-8301	5	Nut-Nyloc 3/8-16 Flg	38	3220-5	2	Nut-Jam 1/2-20
13	121-4870	2	Plug	39	3296-19	1	Nut-Nyloc 1/2-20
14	126-5715-03	1	Arm-Upper	40	3290-357	2	Nut-Whizlock 3/8-16
15	121-6068	1	Cable	41	3231-25	1	Bolt-Carriage 3/8-16 X 1 1/4
16	3296-3	1	Nut-Nyloc 1/4-28	42	3256-23	1	Washer-5/16 Sae
17	121-6060	3	Bushing-Pivot	43	126-5150	1	Pin-Latch, Transport
18	3229-5	3	Screw-CARR	44	126-5151	1	Spring-Compression
19	104-7201	5	Nut-Nyloc 1/4-20 Flg	45	32121-50	1	Pin-Spring
20	3250-27	2	Screw-PPH #10-24 X 7/8	46	126-6291-03	1	Strap, Stop
21	3296-2	2	Nut-Nyloc #10-24	47	126-6500	1	Ring, Handle Lock
22	121-6057	1	Angle-Stop	48	322-3	2	Screw-HH 5/16-18 X 3/4
23	3230-18	2	Bolt-Carriage 5/16-18 X 5/8				

Height Linkage Assembly

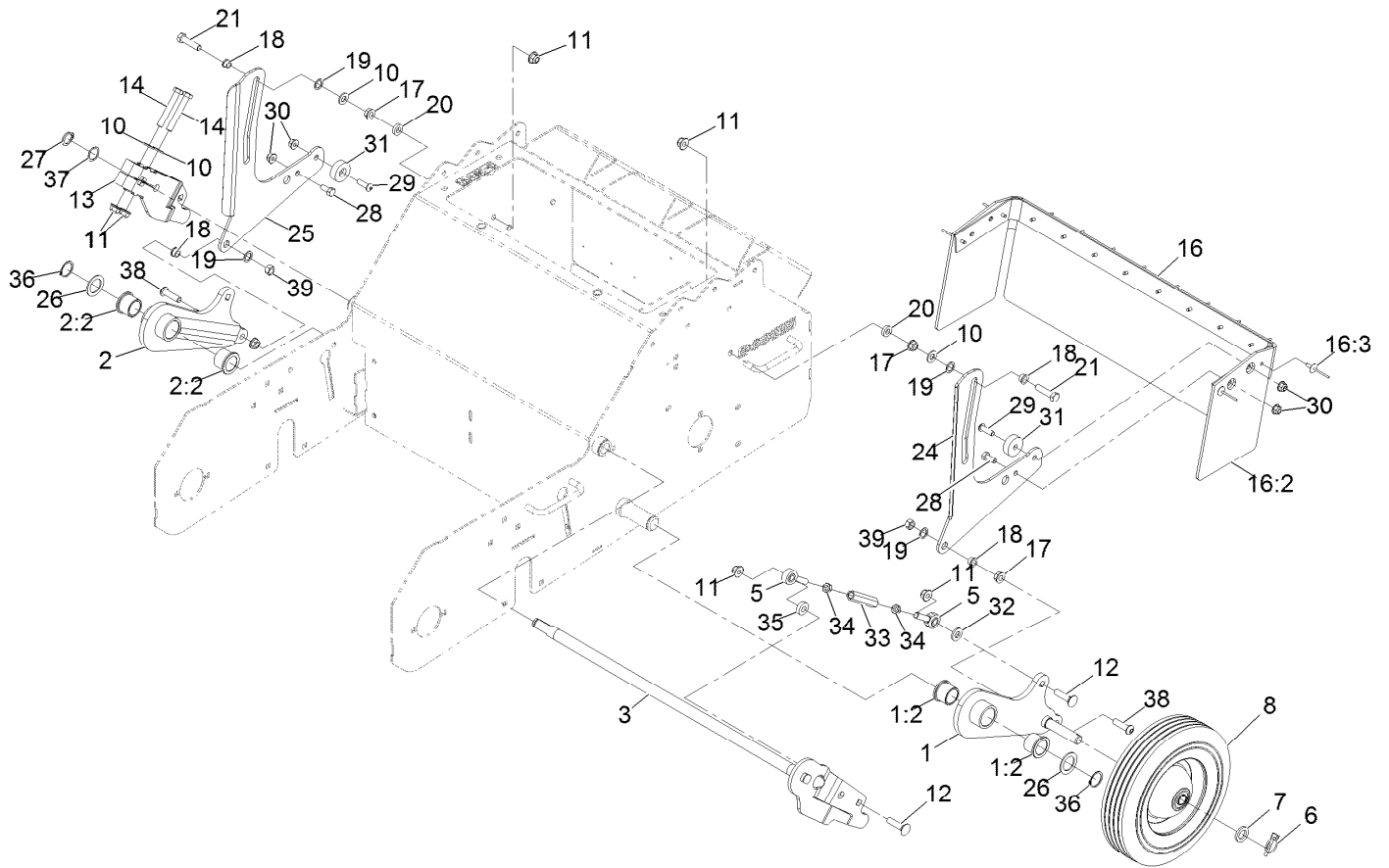

Height Linkage Assembly (continued)

<i>Ref.</i>	<i>Part Number</i>	<i>Qty.</i>	<i>Description</i>	<i>Ref.</i>	<i>Part Number</i>	<i>Qty.</i>	<i>Description</i>
1	126-5098	1	LH Wheel Arm ASM	19	94-8196	4	Washer-Nylon
1:2	94-8949	2	Bushing-Flange	20	80-7730	2	Spacer
2	126-5099	1	RH Wheel Arm ASM	21	323-8	2	Screw-HH 3/8-16 X 1 1/2
2:2	94-8949	2	Bushing-Flange	24	126-0824-01	1	Guard-Arm, LH
3	126-7273	1	Pivot Shaft ASM	25	126-0825-01	1	Guard-Arm, RH
5	1-613204	4	Balljoint	26	1-523157	2	Washer
6	3290-495	2	Pin-Klik	27	32120-93	1	Ring-Retaining
7	63-9710	2	Spacer-Bearing	28	322-3	2	Screw-HH 5/16-18 X 3/4
8	126-9083	2	Wheel, Transport	29	109-4872	2	Screw-Hsph 5/16-18 X 1
10	3256-24	4	Washer-3/8 Sae	30	104-8300	4	Nut-Nyloc 5/16-18 Flg
11	104-8301	8	Nut-Nyloc 3/8-16 Flg	31	116-8331	2	Guide-Arm, Trail
12	3231-4	4	Bolt-Carriage 3/8-16 X 1 1/2	32	87-7480	2	Washer
13	126-1345-03	1	Arm-Lift RH	33	116-9855	2	Rod-Lift Link
14	323-12	2	Screw-HH 3/8-16 X 2 1/2	34	3220-3	4	Nut-Jam 3/8-24
16	126-0564	1	Guard-Foot	35	5-0652	2	Spacer
16:2	116-9884	1	Foot-Shield	36	32151-29	2	Ring-Retaining
16:3	3269-20	12	Rivet-Pop	37	119-4164	1	Washer-Wave
17	3290-357	4	Nut-Whizlock 3/8-16	38	116-9927	2	Screw-HSBH
18	1-603735	4	Bushing-Flanged	39	125-5069	2	Nut-Hex

Tine Wheel Drive Assembly

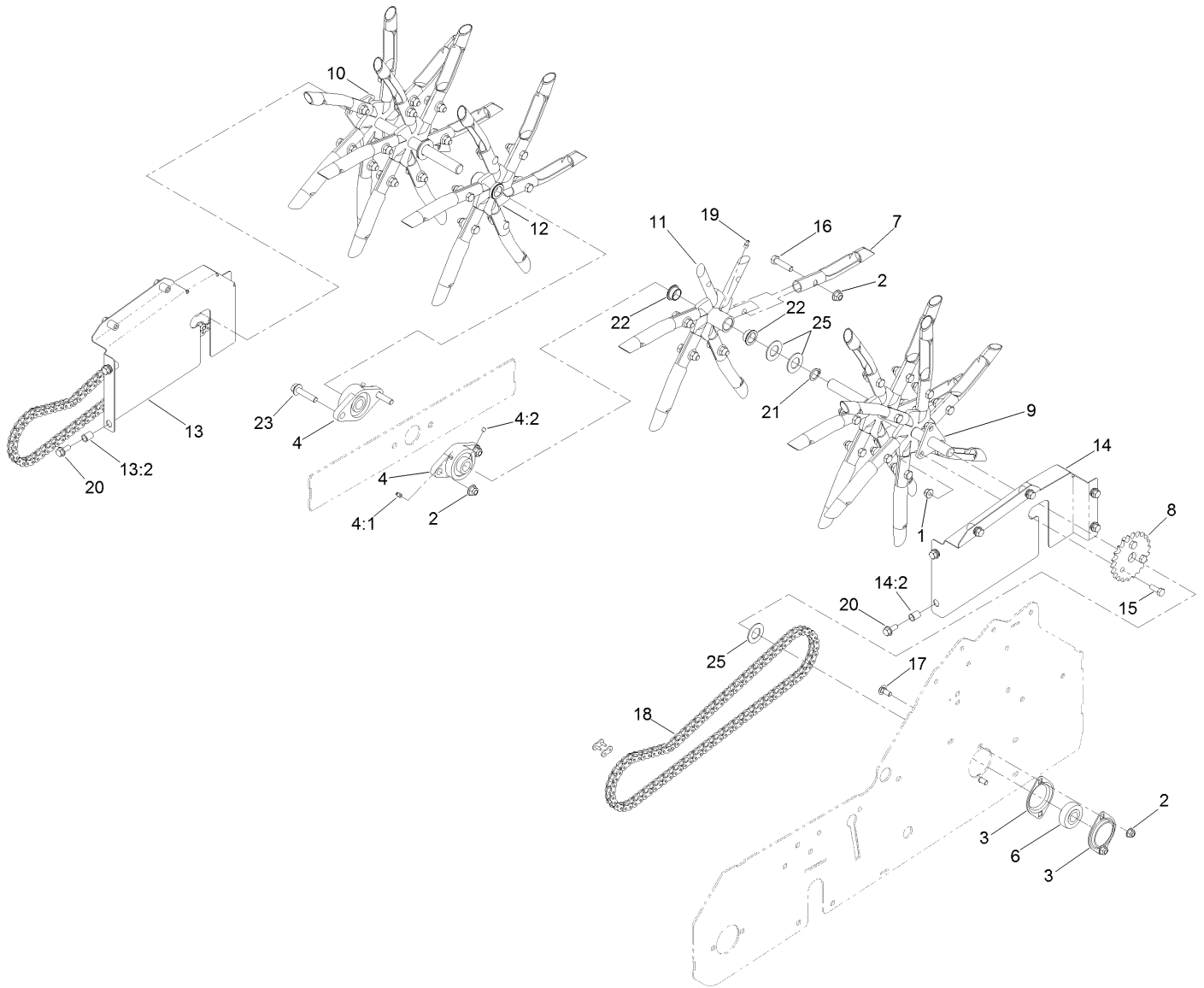

Tine Wheel Drive Assembly (continued)

<i>Ref.</i>	<i>Part Number</i>	<i>Qty.</i>	<i>Description</i>	<i>Ref.</i>	<i>Part Number</i>	<i>Qty.</i>	<i>Description</i>
1	104-8300	10	Nut-Flange, NI	13:2	32148-7	6	Nut-Insert
2	104-8301	38	Nut-Flange, NI	14	126-1206	1	LH Chain Guard ASM
3	105-9714	4	Flange-Bearing	14:2	32148-7	6	Nut-Insert
4	106-7126	2	Bearing-Flange	15	322-4	6	Screw-HH
4:1	302-58	1	Fitting-Straight	16	323-8	36	Screw-HH
4:2	3245-35	2	Screw-Set, HSH	17	3230-1	4	Bolt-CARR
6	120-9350	2	Bearing-Lock, Collar	18	121-6107	2	Chain-Drive
7	126-2143	36	Tine-Coring (3/4 Inch)	19	302-19	2	Fitting-Grease
8	116-9896	2	Sprocket-#40 22T	20	3234-47	12	Screw-HHF
9	121-4930	1	Wheel-Tine, LH	21	32120-93	2	Ring-Retaining
10	121-6072	1	Wheel-Tine, RH	22	108519	4	Bushing-Bronze
11	121-6099	1	Tine-Spyder	23	3234-19	2	Screw-HHF
12	121-6096	1	Tine-Spyder	25	69-8930	6	Washer
13	126-1204	1	RH Chain Guard ASM				

Notes:



MAXIMIZE THE PERFORMANCE OF YOUR EXMARK MACHINE.



EXMARK® PREMIUM ENGINE OIL

Exmark now offers a family of engine oil viscosities to perform well in any environment. Each viscosity has the same synthetic formulation to give you what you need in punishing conditions. We designed each grade to the highest quality, making it ideal even for diesel applications. Coupled with Exmark Premium Fuel Treatment, we have the performance products to make your machine hum.

EXMARK PREMIUM ENGINE OIL SAE 30/10W-30

- Meets zero shear requirements of a straight grade SAE 30 as well as the cold temp properties of a 10W-30.
- Most versatile oil in the industry.
- Superior corrosion protection over conventional oil - even in corrosive, humid environments.

EXMARK PREMIUM ENGINE OIL SAE 20W-50

- Perfect for your big block engine, or any application in severe service.
- Same full synthetic formulation as all other Exmark Premium viscosities.
- Also effective for use in severe service small block engines.

EXMARK PREMIUM ENGINE OIL SAE 10W-50

- Full synthetic formulation gives you peak performance. Don't settle for less.
- Wide span multi-grade combines easy starting in cold weather with maximum protection in high temperature operation.
- Reduce friction & wear over standard mineral formulations.

EXMARK PREMIUM ENGINE OIL SAE 0W-40

- The perfect choice for when the weather turns cold or unpredictable, and your Exmark UTV has to perform.
- Commercial quality for severe service.
- Advanced additive package helps prevent corrosion from long-term storage.

EXMARK PREMIUM ENGINE OIL UTV FORMULATION

- 4-cycle high-temp formulation.
- Heavier viscosity, full synthetic, perfect for your UTV.

EXMARK PREMIUM UTV EXTREME CONDITIONS GEAR OIL

- SAE 80W-90, designed to keep your UTV performing at its peak.
- Shear stable, hypoid gear lube.
- Includes a premium additive system to combat wear, oxidation, rust & corrosion.

Available from your local Exmark dealer. Find your closest dealer at exmark.com

EXMARK ACCESSORIES AND OPTIONS*

MID-MOUNT RIDING ACCESSORIES AND OPTIONS

CUSTOM RIDE SEAT SUSPENSION SYSTEM	OPERATOR CONTROLLED DISCHARGE
FULL SUSPENSION SEAT	SUN SHADE
DECK LIFT ASSIST KIT	TRASH CONTAINER
HITCH KIT	TURF STRIPER
LIGHT KIT	ULTRA VAC COLLECTION SYSTEM
12V POWER PORT	ULTRA VAC QUICK DISPOSAL SYSTEM
MICRO-MULCH SYSTEM	

OUT-FRONT RIDING ACCESSORIES AND OPTIONS

CUSTOM RIDE SEAT SUSPENSION SYSTEM	SNOW BLADE
DUAL-TAIL WHEEL	SNOWBLOWER
FLOOR PAN EXTENDER	SUN SHADE
HITCH KIT	TRASH CONTAINER
LIGHT KIT	ULTRA VAC COLLECTION SYSTEM
MICRO-MULCH SYSTEM	ULTRA VAC QUICK DISPOSAL SYSTEM
ROLL OVER PROTECTION SYSTEM (ROPS)	WEATHER CAB

WALK-BEHIND ACCESSORIES AND OPTIONS

GRASS CATCHER	TURF STRIPER
MICRO-MULCH SYSTEM	STANDON

*Some accessories and options not available for some models.

Place Model No. and Serial No.
Label Here (Included in the Literature
Pack) or Fill in Below

Model No. _____

Serial No. _____

Date Purchased _____

Engine Model No. and Spec. No. _____

Engine Serial No. (E/No) _____

© 2016 Exmark Mfg. Co., Inc.
Industrial Park Box 808
Beatrice, NE 68310
All Rights Reserved

Part No. 4503-222 Rev. A
(402) 223-6375
Fax (402) 223-5489
Printed in the USA.

