



LAZER Z[®] E-SERIES

Model No. LZE751GKA524A2—Serial No. 40000000 and Up

Picture below may not reflect actual product.



Parts Manual

Part No. 4503-141 Rev. A

Ordering Replacement Parts

To order replacement parts, please supply the part number, the quantity, and the description of each part desired.

Understanding Reference Numbers

Each identified part in an illustration has a reference number. The reference number for a part also appears in the parts list, along with other information about the part.

This catalog uses two special reference number formats, one to indicate parts in a service assembly and another to indicate the quantity of a given part in an illustration.

Service Assembly Reference Numbers

Parts in service assemblies have reference numbers in the form a:b. The a represents the reference number of the entire service assembly and the b represents a sequential number unique to each part within the service assembly.

For example, a wheel assembly might be identified by reference number 6, the tire by 6:1, the valve by 6:2, and the wheel by 6:3. When you order the assembly identified by reference number 6, you receive all parts identified by reference numbers 6:1, 6:2, and 6:3. However, you may also order any part individually. Reference numbers of this type appear in illustration and in parts lists.

Reference Numbers Indicating Quantity

In an illustration, if a reference number indicates more than one part, the reference number has the form nX y. The n represents the quantity of the part, the X is the multiplication symbol, and the y represents the reference number.

For example, in an illustration, the reference number 2X 37 means that two of the parts identified by reference number 37 are indicated.

Touch Up Paint

Exmark black touch up spray paint – gloss black.

Exmark red touch up paint (spray paint – P/N 1-850337 - .6 oz liquid bottle – P/N 103-9140).



If your Exmark dealer does not have the Exmark part in stock, Exmark will get the parts to the dealer the next business day or the part will be FREE Guaranteed!! (Some restrictions apply. See your participating Exmark Dealer for details.)

Contents

Complete Deck Assembly	4
Deck Assembly	6
Deck W/Decals Assembly No. 109-9149	8
Idler Assembly	10
Main Frame Assembly	12
E-Series Decal	14
Roll-Over Protection System	16
Roll-Over Protection System Assembly No. 116-2882	18
Front Caster and Fork Assembly	20
Caster Wheel and Fork Assembly	22
Deck Lift Assembly	24
Height-of-Cut Assembly No. 109-7438	26
Control Assembly	28
Motion Control Assembly	30
Rear Wheel Assembly	32
Park Brake Assembly	34
Seat Assembly	36
Seat Assembly (cont.)	38
Fuel Tank Assembly	40
Fuel Tank Assembly No. 126-6493	42
Engine Assembly	44
Hydraulic Assembly	46
LH Hydro Assembly No. 126-1327	48
RH Hydro Assembly No. 126-1328	50
Pump Idler Assembly No. 116-1255	52
Electrical Assembly	54

Complete Deck Assembly

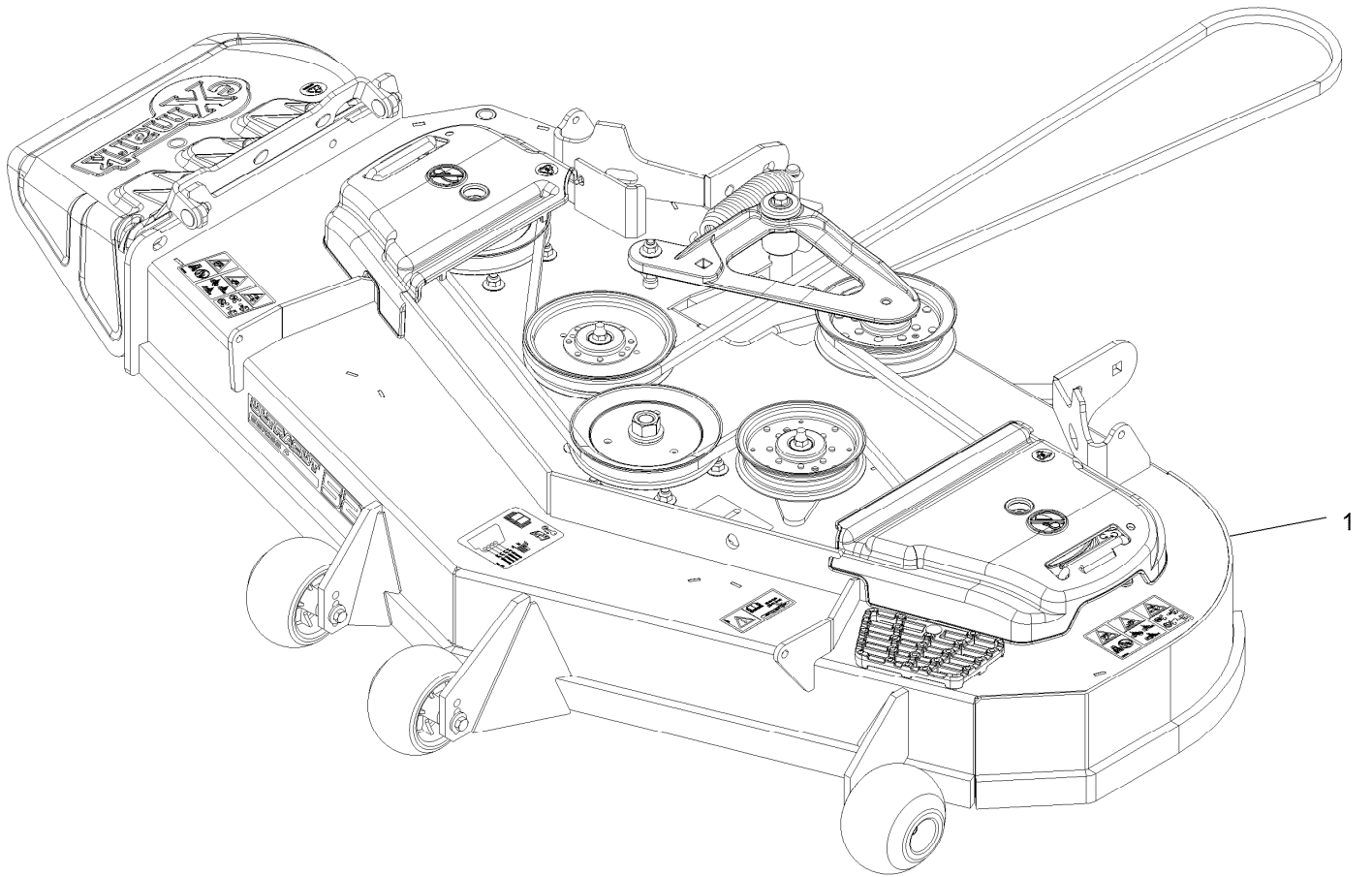

Complete Deck Assembly (continued)

<i>Ref.</i>	<i>Part Number</i>	<i>Qty.</i>	<i>Description</i>
1	116-3598	1	ASM,524 Deck Complete

Deck Assembly

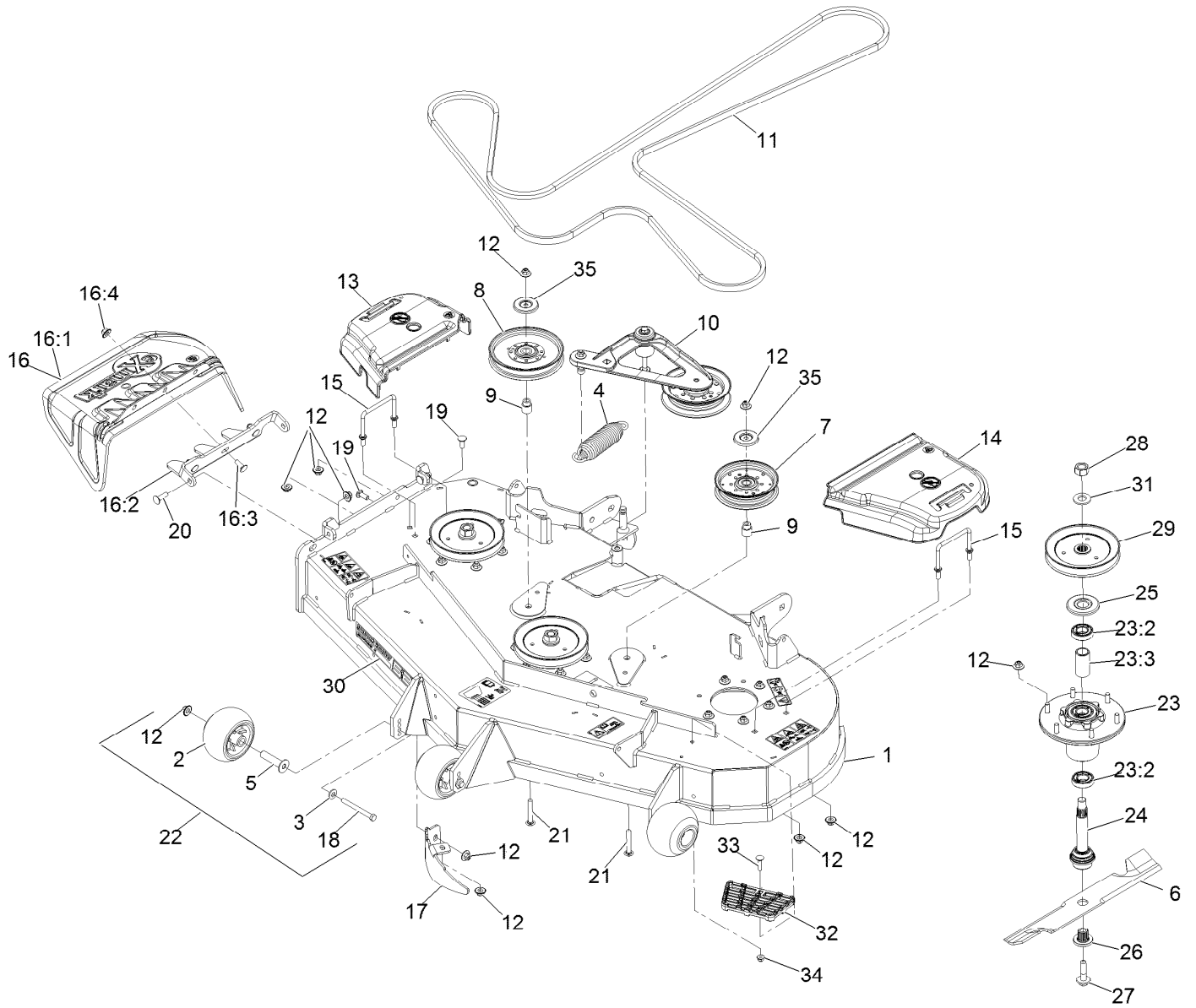

Deck Assembly (continued)

<i>Ref.</i>	<i>Part Number</i>	<i>Qty.</i>	<i>Description</i>	<i>Ref.</i>	<i>Part Number</i>	<i>Qty.</i>	<i>Description</i>
1	109-9149	1	ASM,Deck W/ Decals 52	18	116-9362	3	Screw-HH 3/8-16 X 3 3/4 GR 8
2	103-8415	3	Roller-Anti-Scalp	19	3231-22	2	Bolt-Carriage 3/8-16 X 1
3	98-5975	3	Washer-Spring Disc 3/8	20	3231-28	2	Bolt-Carriage 3/8-16 X 1 1/4
4	116-6317	1	Spring-Extension	21	3231-44	2	Bolt-Carriage 3/8-16 X 2 1/2
5	116-8131	3	Axle, Roller	22	116-9981	3	Kit, Anti-Scalp Roller
6	103-6382	3	Blade, Solid	23	116-3344	3	ASM-Cutter Hsg With Bearings
6	103-6387	3	Blade, Low Lift	23:2	116-0720	2	Bearing-Ball
6	103-6392	3	Blade, Mulching ■	23:3	116-3312	1	Spacer-Bearing
6	103-6402	3	Blade-Notched	24	116-3341	3	ASM-Spindle And Seal ▲
6	116-5175	3	Blade-Extreme 2, 18.00"	25	116-1286	3	Guard,Bearing Top .989
7	126-9187	1	Idler-Pulley, Flat 5.00X0.95	26	103-3037	3	Bushing, Splined
8	126-7685	1	Idler-Pulley, Flat 6.00X0.75	27	109-9220	3	Screw-Sems 1/2-20 X 2.19 ● ◆
9	1-633456	2	Bushing, Idler	28	116-7306	3	Nut-Hex
10	116-3755	1	Deck Idler ASM	29	116-0675	3	Sheave,Blade Drive 6.50
11	109-4994	1	Belt,V-B X 186.00"	30	126-6588	1	Decal, 524
12	109-6658	31	Nut-Nyloc 3/8-16 Flg	31	103-2802	3	Washer-Spring Disc 3/4
13	109-6935	1	Cover-Belt, RH	32	126-4781-03	1	Step-Deck
14	109-6936	1	Cover-Belt, LH	33	3230-3	1	Bolt-Carriage 5/16-18 X 1 1/4
15	109-6982	2	Wireform-Cover	34	104-8300	1	Nut-Nyloc 5/16-18 Flg
16	109-7188	1	ASM,Discharge Chute	35	126-8043	2	Shield-Dust
16:1	109-2738	1	Chute, Discharge				
16:2	109-8675-01	1	Bracket,Discharge Chute				
16:3	3231-22	3	Bolt-Carriage 3/8-16 X 1				
16:4	109-6658	3	Nut-Nyloc 3/8-16 Flg				
17	116-5814-01	1	Baffle-Dogleg, Lz-Vt52				

● Torque to 50-60 ft-lb

■ Requires installation of mulch kit for proper mulching. See your Exmark dealer for details.

▲ Apply Mobil HTS grease (P/N 103-5217 1.5 oz packet) (or a food-grade anti-seize) to spindle shaft

◆ Apply lubricant to threads as needed to prevent seizing. Copper based anti-seize preferable. Grease is an acceptable substitute.

Deck W/Decals Assembly No. 109-9149



Deck W/Decals Assembly No. 109-9149 (continued)

<i>Ref.</i>	<i>Part Number</i>	<i>Qty.</i>	<i>Description</i>	<i>Ref.</i>	<i>Part Number</i>	<i>Qty.</i>	<i>Description</i>
3	126-6464	2	Decal-Danger Thrown Objects	9	1-633456	2	Bushing, Idler
4	109-6036	1	Decal-Roller, Anti-Scalp	10	3231-44	2	Bolt-Carriage 3/8-16 X 2 1/2
5	112-9028	2	Decal-Missing, Cover	11	126-4781-03	1	Step-Deck
6	116-8283	1	Decal-Bolt Torque	12	3230-3	1	Bolt-Carriage 5/16-18 X 1 1/4
7	116-8727	1	Decal-Belt Routing	13	104-8300	1	Nut-Nyloc 5/16-18 Flg
8	109-6658	2	Nut-Nyloc 3/8-16 Flg				

Idler Assembly



Idler Assembly (continued)

<i>Ref.</i>	<i>Part Number</i>	<i>Qty.</i>	<i>Description</i>	<i>Ref.</i>	<i>Part Number</i>	<i>Qty.</i>	<i>Description</i>
1	43-0940	1	Spacer	9	126-0423	1	Pin-Spring, Anchor
2	103-2916	1	Guard-Top	10	109-6658	2	Nut-Flange, NI
3	103-3504	2	Bearing-Spherical	11	109-7409	1	Screw-Shoulder, HH
4	103-3505	1	Seal-Double Lip	12	323-8	1	Screw-HH
5	103-3506	1	Seal-Lip, Single	13	32120-10	2	Ring-Snap
6	126-9196	1	Idler-Pulley, Flat 5.00X0.87	14	302-19	1	Fitting-Grease
7	106-7159	2	O-Ring	15	126-9195	1	Guard-Dust Shield

Main Frame Assembly

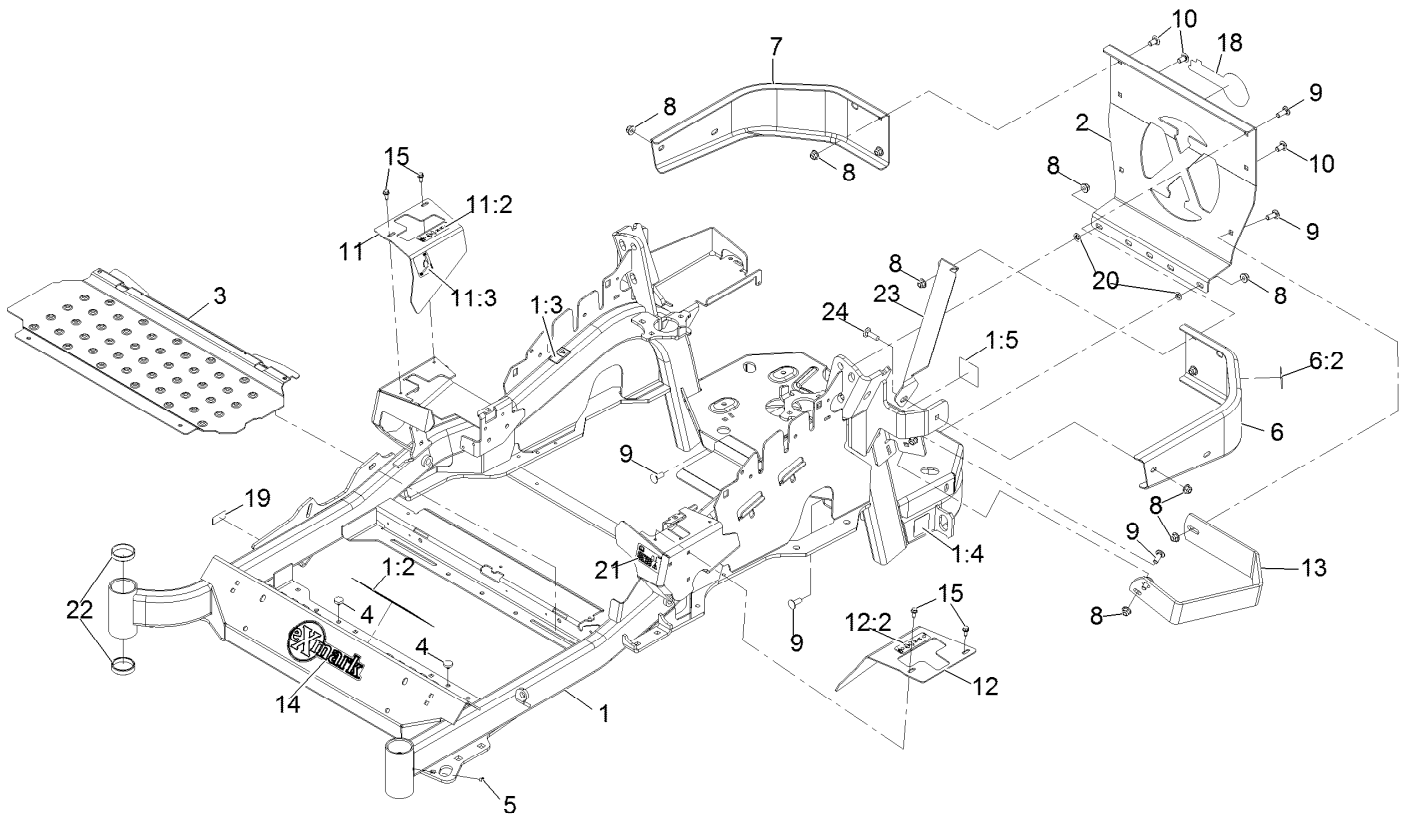

Main Frame Assembly (continued)

<i>Ref.</i>	<i>Part Number</i>	<i>Qty.</i>	<i>Description</i>	<i>Ref.</i>	<i>Part Number</i>	<i>Qty.</i>	<i>Description</i>
1	116-5900	1	Mainframe ASM	11:2	99-8936	1	Decal-Control, Motion
1:2	132-0871	1	Decal-Danger	11:3	116-5988	1	Decal-Park Brake, CE
1:3	106-5517	2	Decal-Warning	12	116-0580	1	LH Motion Control Cover ASM
1:4	106-2655	2	Decal-Hazard, Pinched Finger	12:2	99-8936	1	Decal-Control, Motion
1:5	116-4858	1	Decal-Spark Arrester	13	126-2067-03	1	Guard-Muffler
2	109-8863-03	1	Plate,Rear Guard	14	126-6969	1	Decal-Exmark Logo
3	116-8898-01	1	Floorpan	15	32144-10	4	Screw-HWH 1/4-20 X .62
4	1-513658	2	Bumper	18	126-6965	1	Decal-Exmark Logo
5	1-811010	2	Plug	19	126-4345	1	Decal-Patent
6	116-0180	1	LH Bumper ASM	20	107-3154	2	Nut-Push 3/8-16
6:2	106-5517	1	Decal-Warning	21	117-3864	1	Decal-Fuel Fill, CE
7	116-0057-03	1	Bumper-RH	22	1-543508	4	Cup-Bearing Tapered Roller
8	104-8301	11	Nut-Nyloc 3/8-16 Flg	23	127-0324-03	1	Strap
9	3231-22	7	Bolt-Carriage 3/8-16 X 1	24	3231-25	1	Bolt-Carriage 3/8-16 X 1 1/4
10	3231-21	3	Bolt-Carriage 3/8-16 X 3/4				
11	116-5899	1	RH Motion Control Cover ASM				

E-Series Decal



E-Series Decal (continued)

<i>Ref.</i>	<i>Part Number</i>	<i>Qty.</i>	<i>Description</i>
1	126-6571	2	Decal-E-Series

Roll-Over Protection System



Roll-Over Protection System (continued)

<i>Ref.</i>	<i>Part Number</i>	<i>Qty.</i>	<i>Description</i>
1	116-2882	1	ROPS ASM

Roll-Over Protection System Assembly No. 116-2882

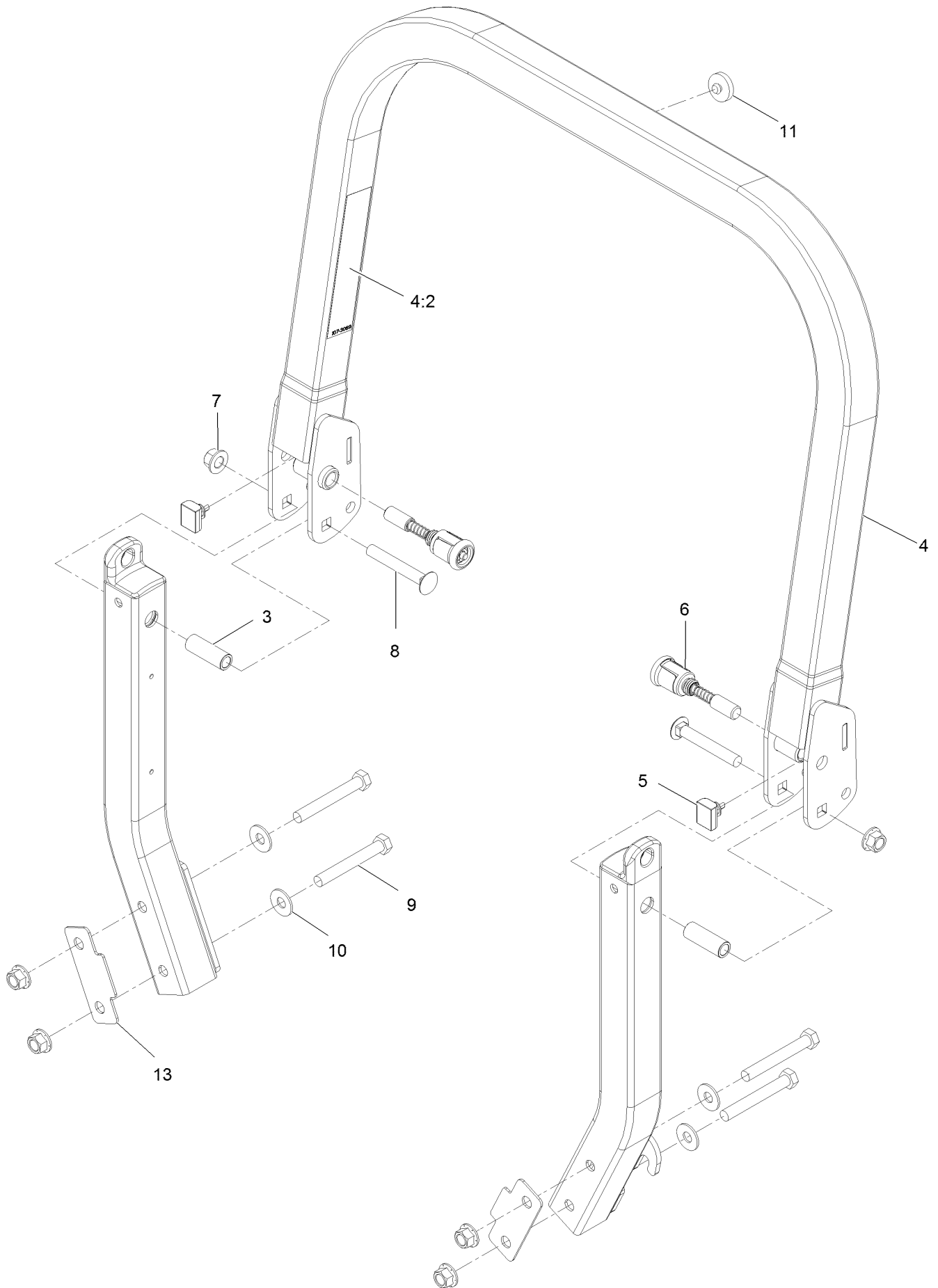

Roll-Over Protection System Assembly No. 116-2882 (continued)

<i>Ref.</i>	<i>Part Number</i>	<i>Qty.</i>	<i>Description</i>	<i>Ref.</i>	<i>Part Number</i>	<i>Qty.</i>	<i>Description</i>
3	109-6653	2	Spacer	8	3233-10	2	Bolt-Carriage 1/2-13 X 3 1/2
4	116-0019	1	Upper ROPS ASM	9	325-35	4	Screw-HH
4:2	107-3069	1	Decal-Warning	10	109-9505	4	Washer, Spring Disc 1/2
5	109-5337	2	Bumper-ROPS	11	109-9233	1	Bumper-Push-In, Rubber
6	116-0104	2	Pin-Spring	13	116-0960	2	Spacer
7	99-5107	6	Nut-Lock 1/2-13				

Front Caster and Fork Assembly

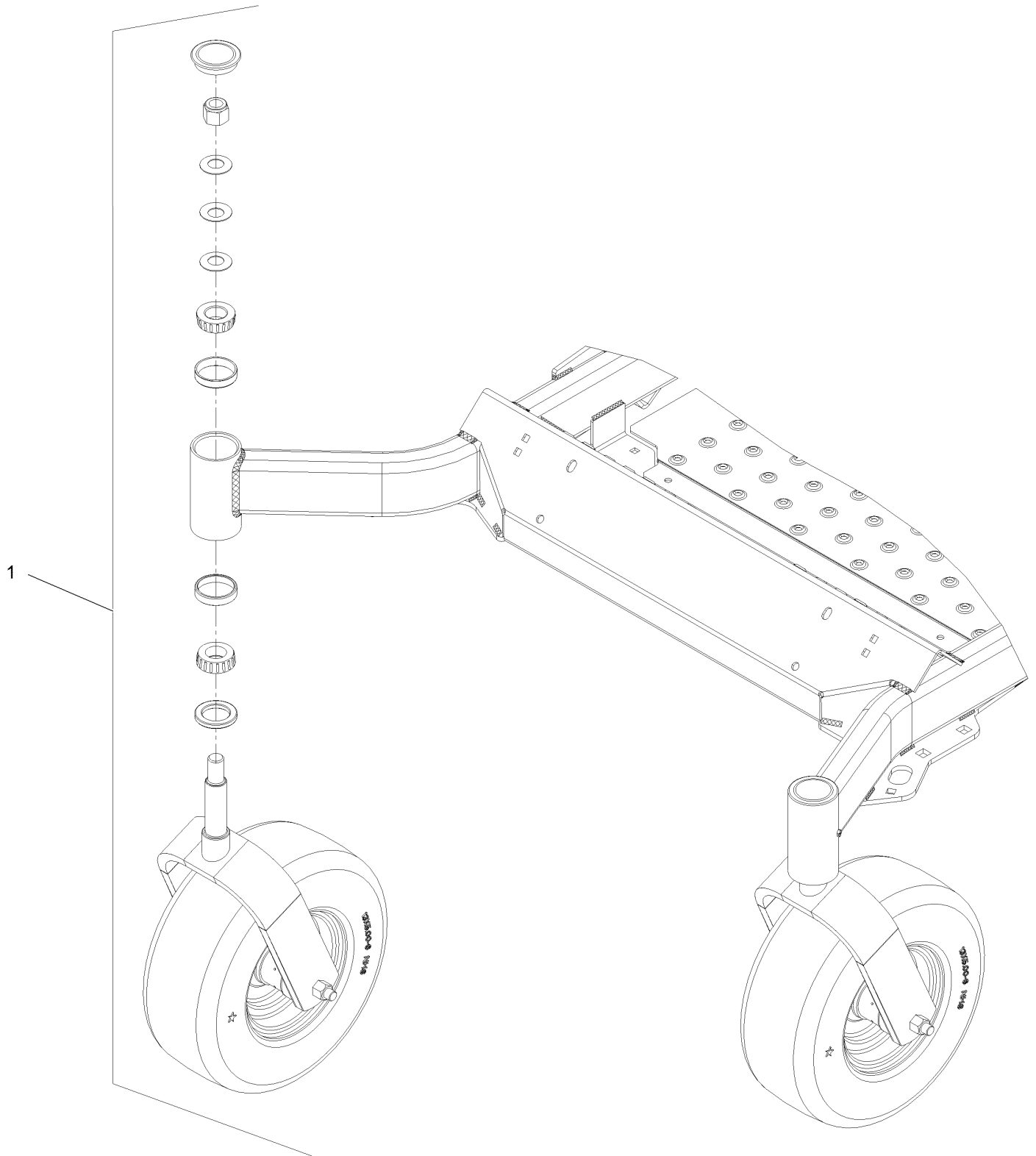

Front Caster and Fork Assembly (continued)

<i>Ref.</i>	<i>Part Number</i>	<i>Qty.</i>	<i>Description</i>
1		2	Front Caster And Fork ASM
			●

● Not serviced separately

Caster Wheel and Fork Assembly

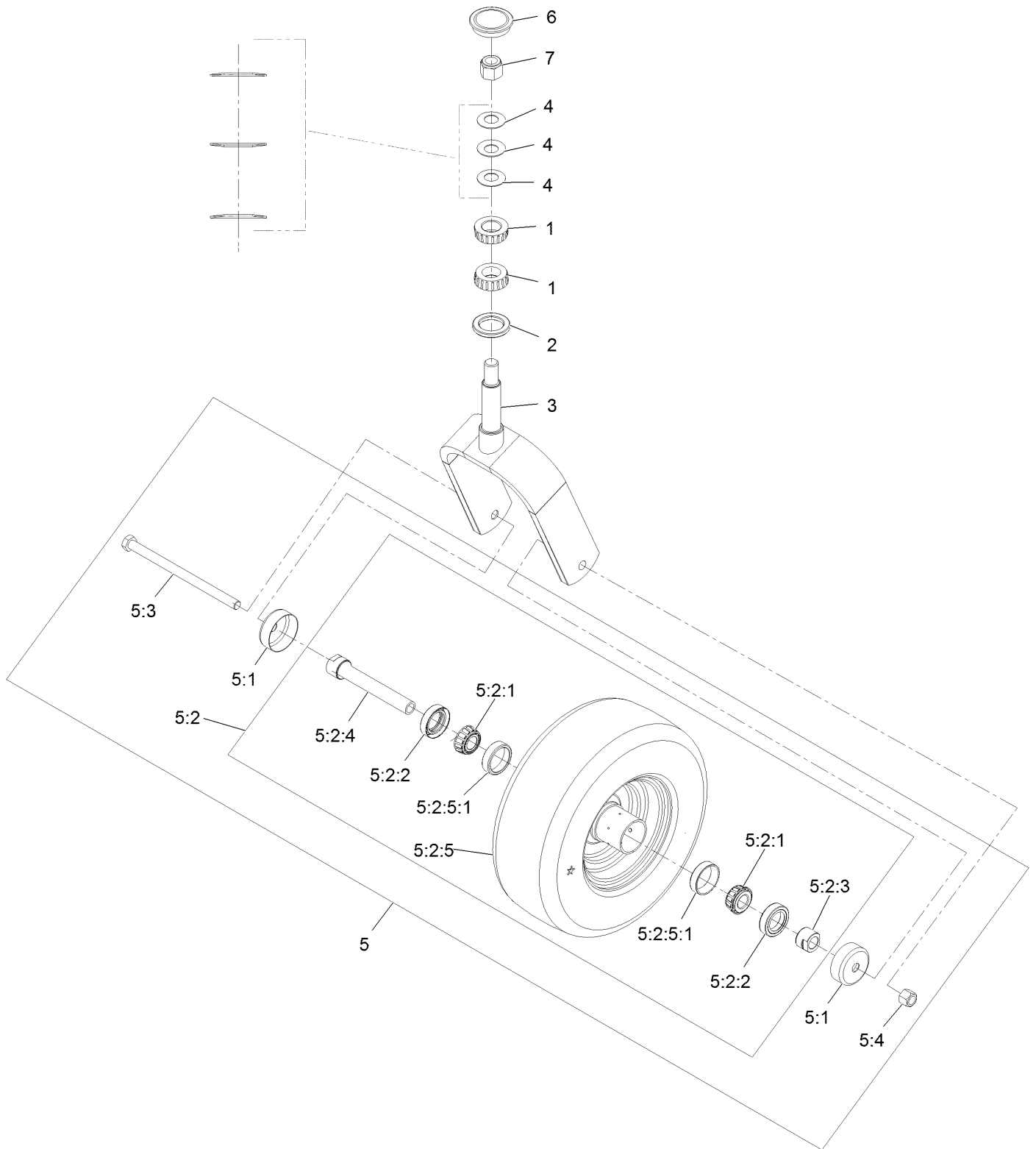

Caster Wheel and Fork Assembly (continued)

<i>Ref.</i>	<i>Part Number</i>	<i>Qty.</i>	<i>Description</i>	<i>Ref.</i>	<i>Part Number</i>	<i>Qty.</i>	<i>Description</i>
1	1-543509	2	Cone-Bearing Tapered Roller	5:2:2	103-0063	2	Seal-Double Lip
2	116-5647	1	Seal-Grease	5:2:3	103-3051	1	Spacer-Nut ■
3	116-6703-01	1	Weld, Fork	5:2:4	126-5360	1	Axle ASM-Caster
4	1-633508	3	Washer-Spring Disc	5:2:5		1	Wheel And Tire ASM ●
5	109-9126	1	Wheel & Tire ASM	5:2:5:1	1-633584	2	Bearing-Cup
5:1	103-2768	2	Guard-Seal	5:3	325-42	1	Screw-HH 1/2-13 X 8
5:2		1	Wheel And Tire ASM ●	5:4	3296-23	1	Nut-Nyloc 1/2-13
5:2:1	1-633585	2	Bearing-Cone Tapered Roller	6	103-4882	1	Cap-Grease
				7	3296-51	1	Nut-Nyloc 3/4-10

● Not serviced separately

■ Use Pro-Lock, Nut Type (P/N 1-840022, .5ml tube) on threads.

Deck Lift Assembly

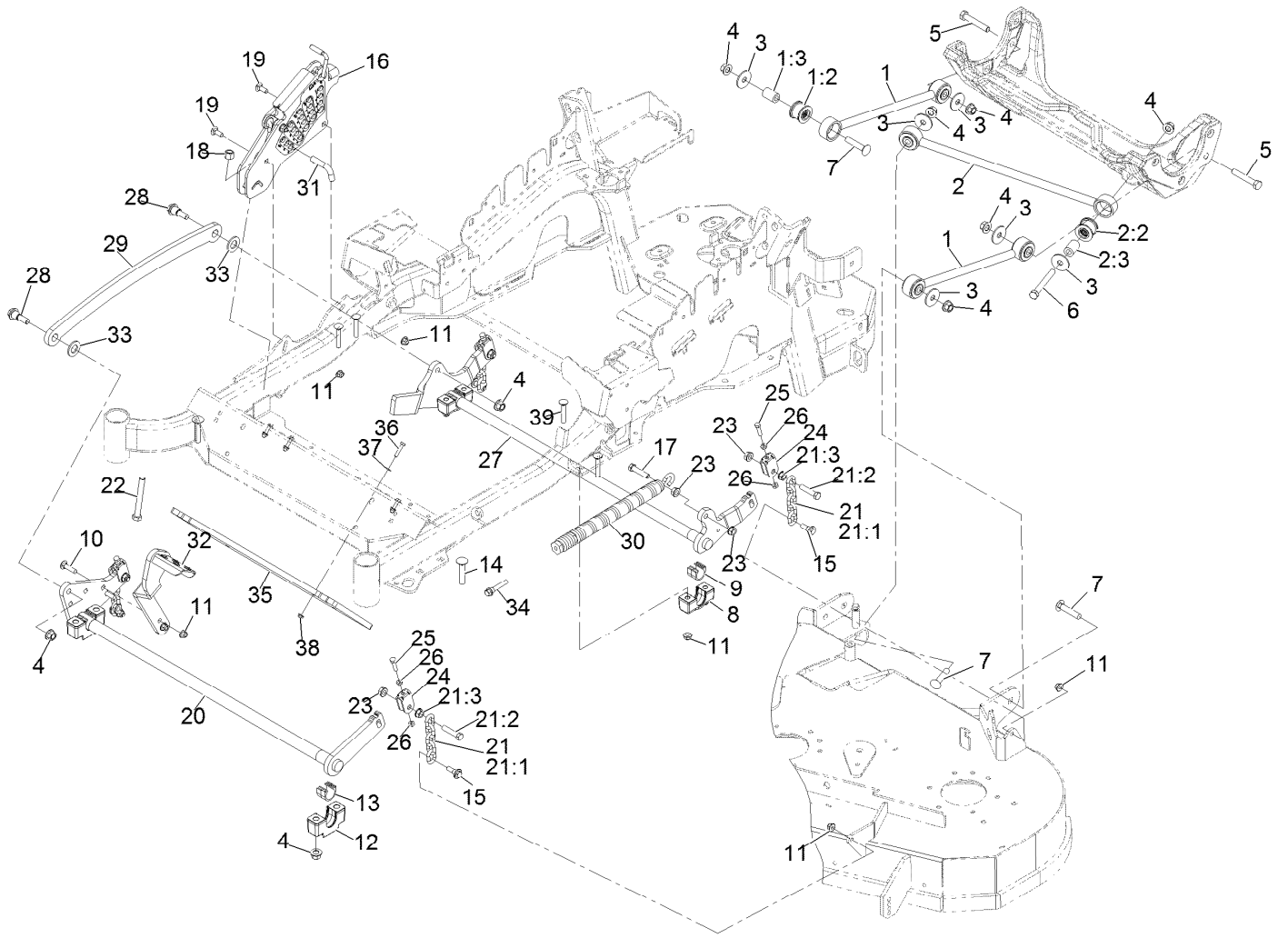

Deck Lift Assembly (continued)

<i>Ref.</i>	<i>Part Number</i>	<i>Qty.</i>	<i>Description</i>	<i>Ref.</i>	<i>Part Number</i>	<i>Qty.</i>	<i>Description</i>
1	109-7952	2	Deck Strut ASM	18	3296-23	1	Nut-Nyloc 1/2-13
1:2	109-5009	2	Bushing-Suspension, Rubber	19	3231-2	2	Bolt-Carriage 3/8-16 X 1
1:3	109-5010	2	Spacer	20	126-2475-03	1	Decklift-Front
2	109-5013	1	Panhard Rod ASM	21	116-0756	4	Deck Lift Chain ASM
2:2	109-5009	2	Bushing-Suspension, Rubber	21:1	1-633447	1	Chain-Lift, Deck
2:3	109-5010	2	Spacer	21:2	109-9065	1	Screw-HH 7/16-14 X 2
3	86-1990	6	Washer	21:3	32128-37	1	Nut-Whizlock 7/16-14
4	99-5107	12	Nut-Lock 1/2-13	22	116-0559	1	Bolt-HH 1/2-13 X 4 Tap
5	325-12	2	Screw-HH 1/2-13 X 3	23	32128-37	6	Nut-Whizlock 7/16-14
6	325-17	1	Screw-HH 1/2-13 X 4	24	109-9066	4	Yoke-Adjust, Deck
7	3233-34	3	Bolt-Carriage 1/2-13 X 2 1/2	25	322-47	4	Screw-HH 5/16-18 X 1 1/4
8	127-0553	2	Support-Cross Shaft, Bearing Rear	26	3218-2	8	Nut-Jam 5/16-18
9	109-7173	2	Bearing-Cross Shaft, Rear	27	116-0459-03	1	Lift-Deck, Rear
10	3231-4	2	Bolt-Carriage 3/8-16 X 1 1/2	28	116-0780	2	Screw-Shoulder HHF 1/2-13 X 1.12
11	104-8301	12	Nut-Nyloc 3/8-16 Flg	29	116-0797-03	1	Link-Lift, Deck
12	109-9409	2	Support-Cross Shaft, Bearing	30	116-0886	1	Extension Spring ASM
13	109-9410	2	Bearing-Cross Shaft, Front	31	116-5584	1	Pin-HOC
14	116-1700	4	Bolt-Carriage 1/2-13 X 2 1/2 Spl Neck	32	116-1919-01	1	Lever-Foot
15	109-9840	4	Screw-Hex Flange 3/8-16 X .80	33	3256-28	2	Washer-3/4 Sae
16	109-7438	1	HOC ASM	34	92-7674	1	Screw-Shcs 3/8-16 X 2.212
17	109-9065	1	Screw-HH 7/16-14 X 2	35	132-5075-01	1	Weight-Toe Board
				36	321-8	4	Screw-HH 1/4-20 X 1 1/4
				37	3256-22	4	Washer-1/4 Sae
				38	104-7201	4	Nut-Nyloc 1/4-20 Flg
				39	3231-7	4	Bolt-Carriage 3/8-16 X 2 1/4

Height-of-Cut Assembly No. 109-7438



Height-of-Cut Assembly No. 109-7438 (continued)

<i>Ref.</i>	<i>Part Number</i>	<i>Qty.</i>	<i>Description</i>	<i>Ref.</i>	<i>Part Number</i>	<i>Qty.</i>	<i>Description</i>
1	62-1330	1	Bolt-Shoulder	6	116-0118	1	Pawl-Transport, HOC
2	109-7130	1	Grommet	7	109-7335	1	HOC Plate ASM
3	104-8301	1	Nut-Flange, NI	7:2	126-4398	1	Decal-HOC
4	109-7124	1	Spring-Extension	8	109-8250	1	Grip-Lever
5	109-7128	1	Rod-Lock, Transport				

Control Assembly

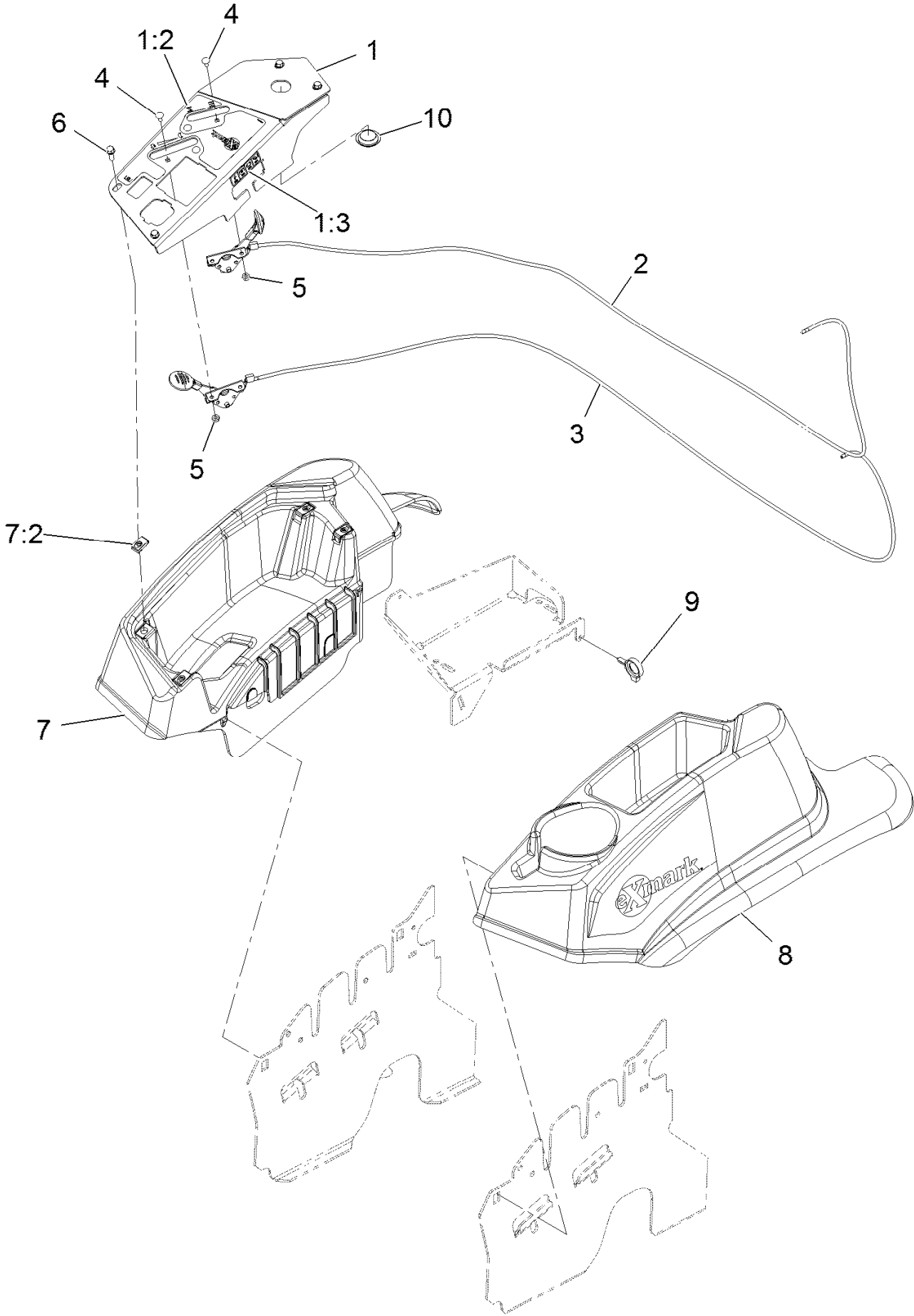

Control Assembly (continued)

<i>Ref.</i>	<i>Part Number</i>	<i>Qty.</i>	<i>Description</i>	<i>Ref.</i>	<i>Part Number</i>	<i>Qty.</i>	<i>Description</i>
1	109-8484	1	Console,Panel W/Decal	6	32105-15	4	Screw-Machine 1/4-20 X 3/4
1:2	116-8724	1	Decal-Control Panel Non-Efi	7	116-1278	1	Console,RH As ASM
1:3	114-4466	1	Decal-Fuses	7:2	107069	4	Nut-Retainer-Panel 1/4-20
2	109-8167	1	ASM, Choke Cable	8	109-9457	1	Console, LH As
3	116-1972	1	ASM,Throttle Cable	9	105-1853	1	Clamp-Hose
4	1-807513	4	Bolt-Carriage #10-24 X 1/2	10	116-1875	1	Plug,Plastic
5	3296-2	4	Nut-Nyloc #10-24				

Motion Control Assembly

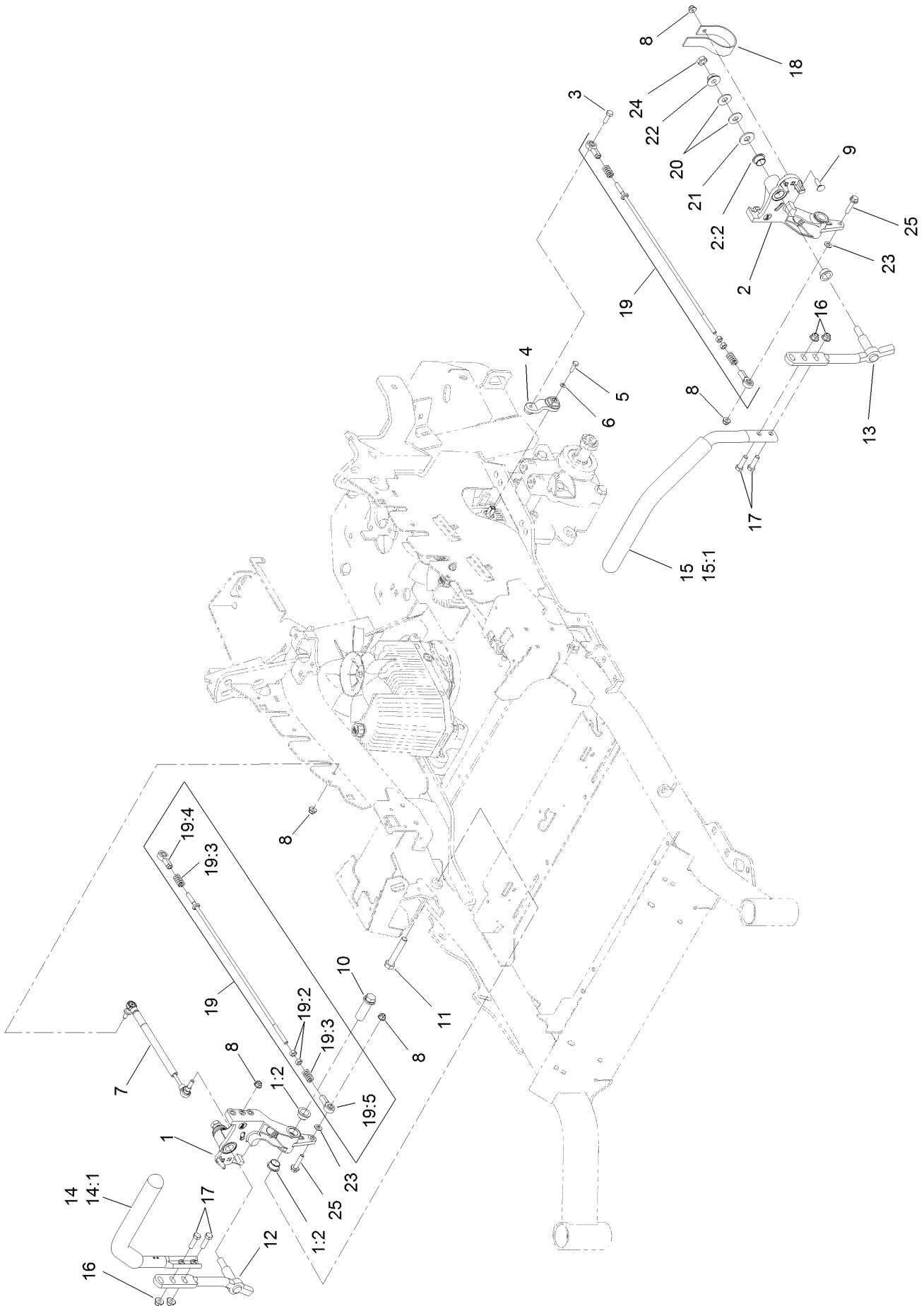

Motion Control Assembly (continued)

<i>Ref.</i>	<i>Part Number</i>	<i>Qty.</i>	<i>Description</i>	<i>Ref.</i>	<i>Part Number</i>	<i>Qty.</i>	<i>Description</i>
1	116-0880	1	RH Motion Control And Bushing ASM	14	109-6589	1	RH Steering Handle ASM
1:2	109-8054	4	Bushing-Flange	14:1	109-5668	1	Grip-Control, Lever
2	116-0881	1	LH Motion Control And Bushing ASM	15	109-6590	1	LH Steering Handle ASM
2:2	109-8054	4	Bushing-Flange	15:1	109-5668	1	Grip-Control, Lever
3	116-0648	2	Screw-HH, Thread Locking ●	16	104-8301	4	Nut-Flange, NI
4	109-4581	2	Arm-Control, Pump	17	323-7	4	Screw-HH
5	9080046	2	Screw-HH ●	18	109-5575	2	Spring-Leaf
6	1-303435	2	Washer-Spring	19	109-8107	2	Pump Linkage Rear ASM
7	116-0027	2	Damper-Control, Motion	19:2	3219-2	2	Nut-Hex
8	104-8300	8	Nut-Flange, NI	19:3	1-323245	2	Spring-Compression
9	3230-2	2	Bolt-CARR	19:4	1-633152	1	Balljoint-LH
10	109-5891	2	Hub-Threaded	19:5	1-543017	1	Balljoint-RH
11	325-12	2	Screw-HH	20	109-9505	4	Washer-Spring
12	116-0039	1	Lever-Control Motion, RH	21	3256-6	2	Washer-Flat
13	116-0040	1	Lever-Control Motion, LH	22	32128-56	2	Nut-HF
				23	3256-23	2	Washer-Flat
				24	3218-5	2	Nut-Jam
				25	115-1794	2	Screw-HHF

● Use Pro-Lock, Nut Type (P/N 1-840022, .5ml tube) on threads.

Rear Wheel Assembly

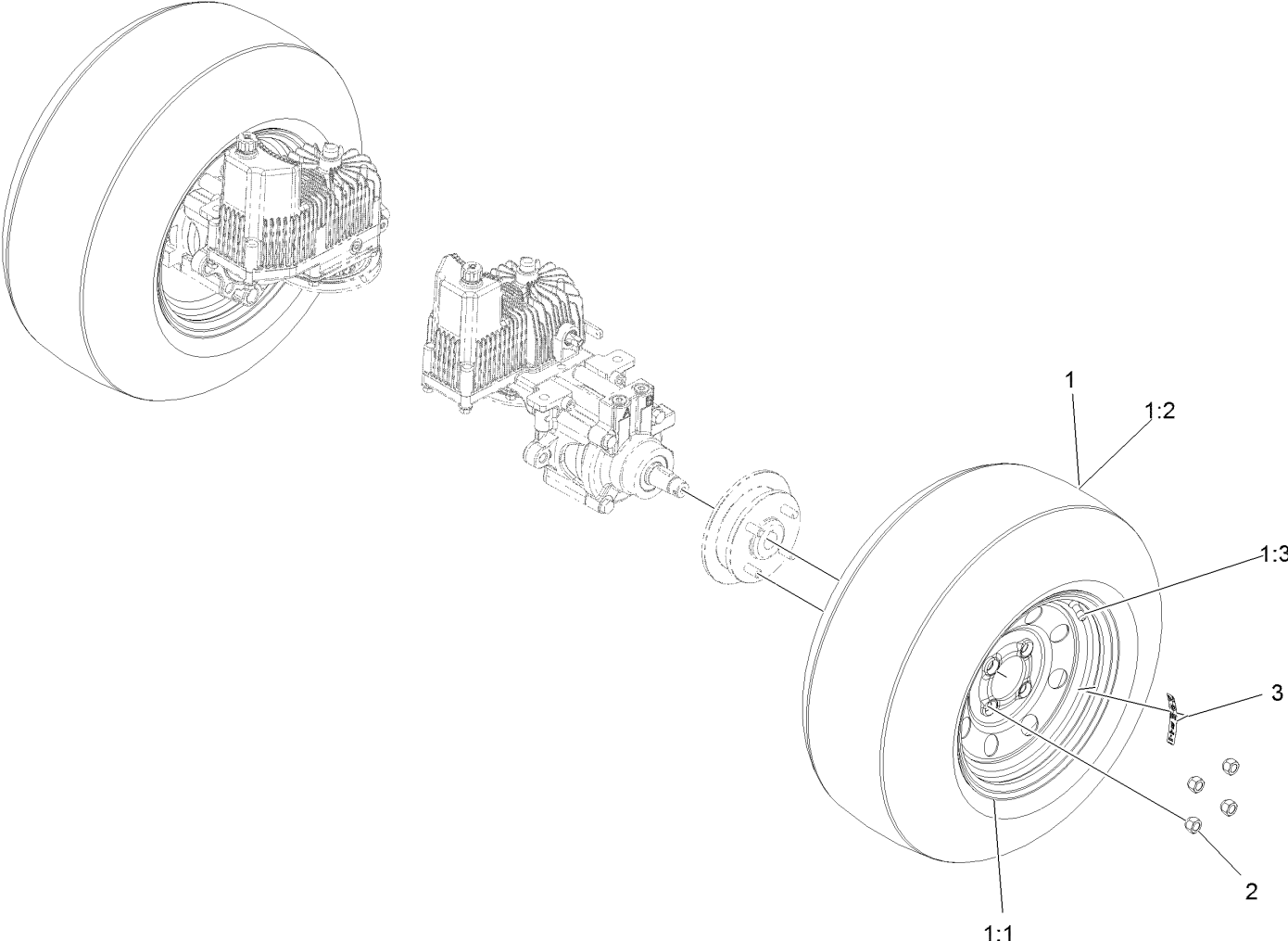

Rear Wheel Assembly (continued)

<i>Ref.</i>	<i>Part Number</i>	<i>Qty.</i>	<i>Description</i>	<i>Ref.</i>	<i>Part Number</i>	<i>Qty.</i>	<i>Description</i>
1	116-8289	2	Wheel And Tire ASM	2	242-50	8	Nut-Lug 1/2-20
1:1	116-8290	1	ASM, Rim	3	126-2055	2	Decal-Torque, Wheel Hub Lug
1:2	116-8291	1	Tire-Drive, 23X9.5-12				
1:3	232-27	1	Stem-Valve				

Park Brake Assembly

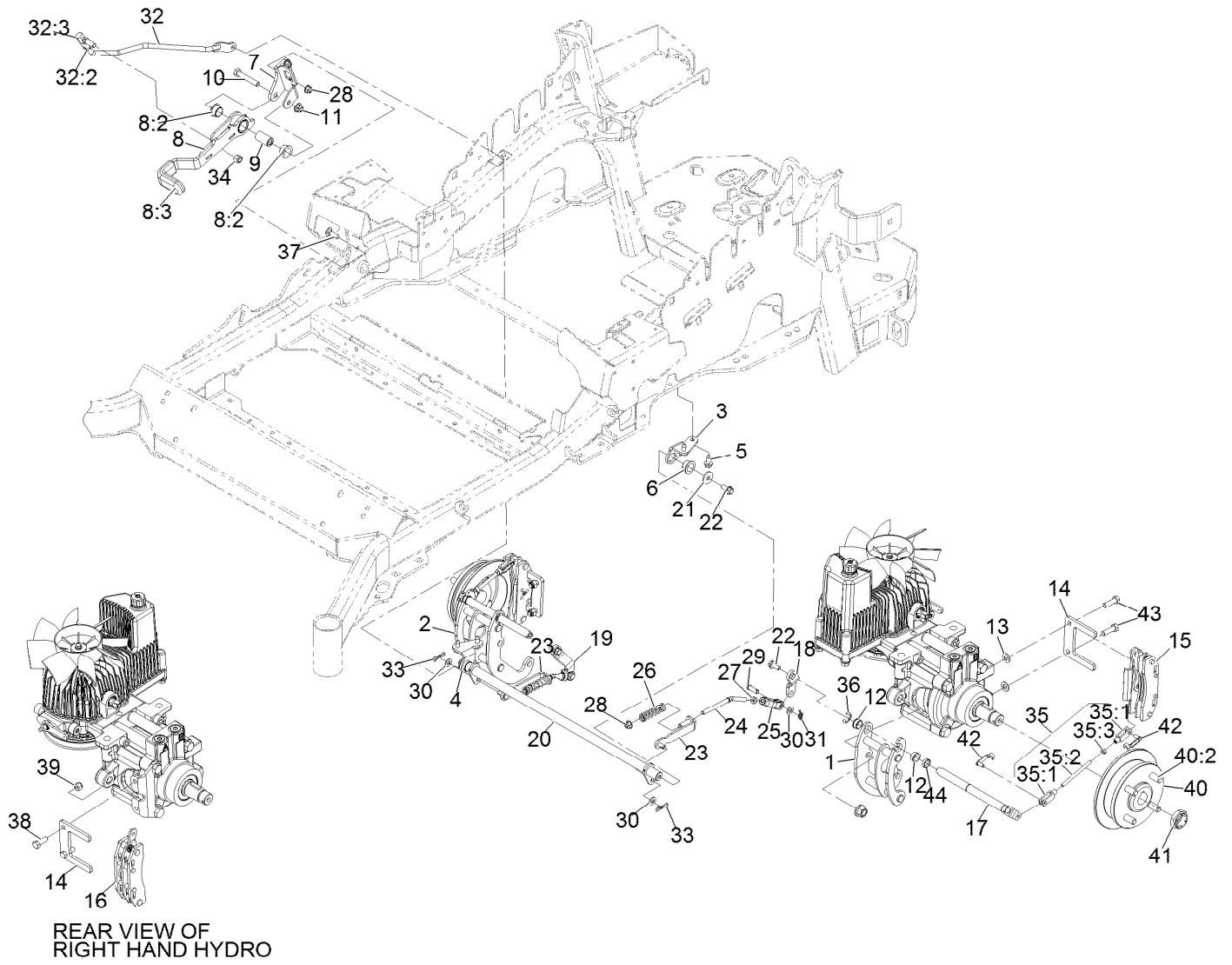

Park Brake Assembly (continued)

<i>Ref.</i>	<i>Part Number</i>	<i>Qty.</i>	<i>Description</i>	<i>Ref.</i>	<i>Part Number</i>	<i>Qty.</i>	<i>Description</i>
1	126-4248	1	Mount-Bellcrank, LH	26	116-9085	2	Spring-Compression
2	126-4249	1	Mount-Bellcrank, RH	27	3220-2	2	Nut-Jam 5/16-24
3	116-9681	1	Mount-Pivot, LH	28	104-8300	4	Nut-Nyloc 5/16-18 Flg
4	116-9682	1	Mount-Pivot, RH	29	1-808280	2	Pin-Clevis 5/16 X 1 49/64
5	32144-70	4	Screw-HWH 5/16-18 X 3/4 Tf	30	3256-23	4	Washer-5/16 Sae
6	109-8054	2	Bushing-Flanged	31	116-6639	2	Pin-Cotter, Locking
7	116-9096-01	1	Bracket-Mount	32	116-9102	1	Front Linkage ASM
8	126-0970	1	Brake Lever ASM	32:2	94-7572	1	End-Tie Rod, RH
8:2	109-8054	2	Bushing-Flanged	32:3	3220-3	1	Nut-Jam 3/8-24
8:3	1-633268	1	Grip-Lever	33	119-1415	2	Pin-Cotter, Locking
9	116-9117	1	Handle-Pivot, Brake	34	3296-6	1	Nut-Nyloc 3/8-24
10	323-11	1	Screw-HH 3/8-16 X 2 1/4	35	126-7587	2	Rear Linkage ASM
11	104-8301	1	Nut-Nyloc 3/8-16 Flg	35:1	126-7588	2	Yoke
12	126-6199	4	Bushing-Igus	35:2	116-9069	1	Linkage, Rear
13	3256-24	2	Washer-3/8 Sae	35:3	3220-1	1	Nut-Jam 1/4-28
14	109-0958	2	Plate-Mount, Brake	36	32120-19	2	E-Ring
15	109-2889	1	Caliper-Brake	37	3230-2	2	Bolt-Carriage 5/16-18 X 1
16	116-9103	1	Caliper-Brake, RH	38	323-6	2	Screw-HH 3/8-16 X 1
17	126-4251	2	Bellcrank	39	3296-39	2	Nut-Nyloc 3/8-16
18	126-3715	1	Arm-Inner, LH	40	116-1746	2	Wheel Hub ASM
19	126-3716	1	Arm-Inner, RH	40:2	116-1696	4	Stud-Wheel
20	116-9080	1	Shaft-Cross	41	116-1399	2	Locknut
21	115-7109	2	Washer-Flat	42	126-6395	4	Pin-Clevis, Spring
22	98-9940	4	Screw	43	92-5727	2	Screw-HH 3/8-16 X 1 1/4 Patch Lock
23	116-9608	2	Bracket-L	44	126-6200	2	Spacer
24	116-9086	2	Linkage-Mid				
25	126-3693	2	Yoke-Offset				

Seat Assembly

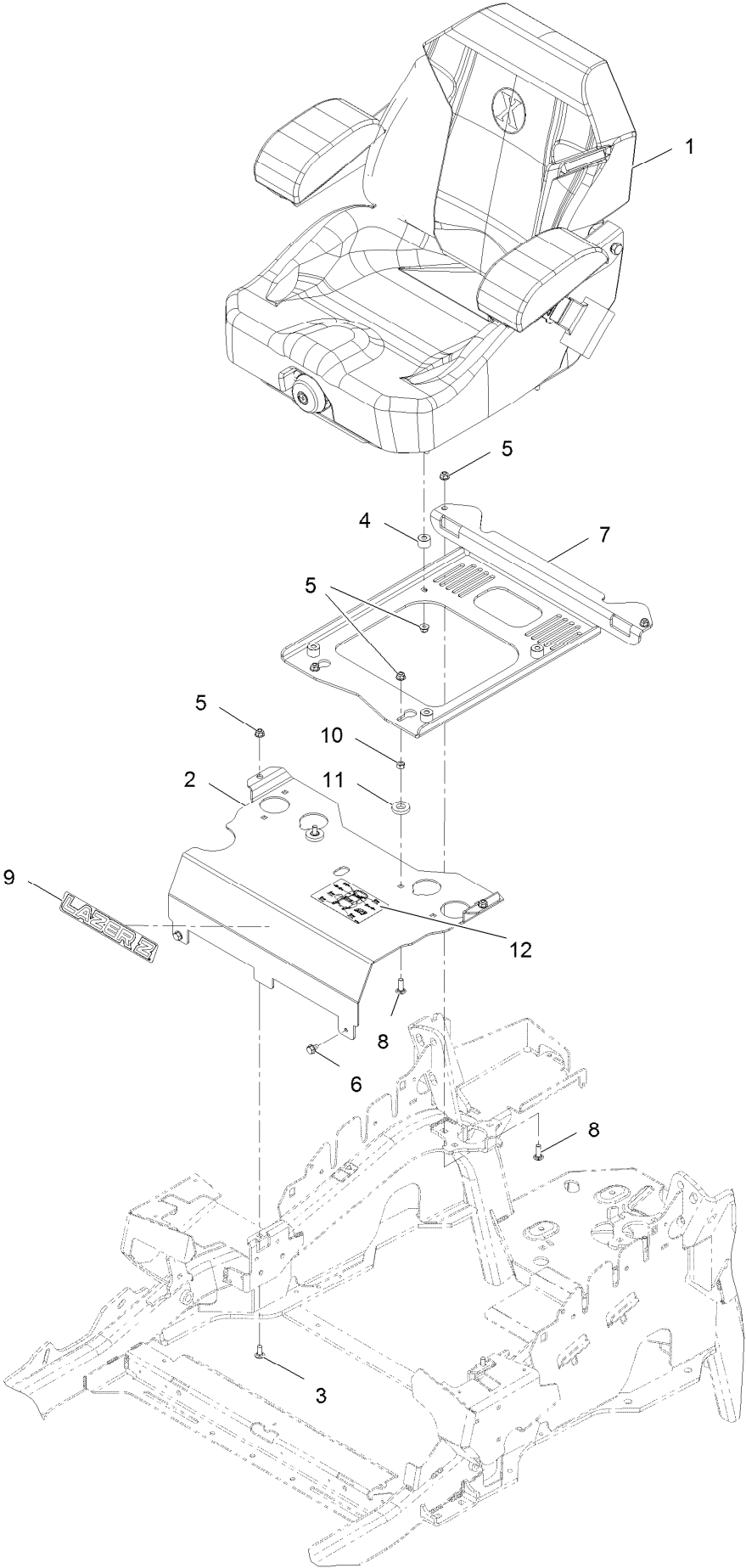

Seat Assembly (continued)

<i>Ref.</i>	<i>Part Number</i>	<i>Qty.</i>	<i>Description</i>	<i>Ref.</i>	<i>Part Number</i>	<i>Qty.</i>	<i>Description</i>
1	116-8912	1	Kit-Suspension Seat	7	116-0192-03	1	Plate-Support, Seat
2	116-2130-03	1	Panel-Front, Seat Mount	8	3230-22	4	Bolt-Carriage 5/16-18 X 1 Sp
3	3230-23	2	Bolt-Carriage 5/16-18 X 3/4 Short Neck	9	126-6574	1	Decal, Lazer Model
4	116-9329	4	Spacer	10	3217-6	2	Nut-Hex 5/16-18
5	104-8300	10	Nut-Nyloc 5/16-18 Flg	11	1-323539	2	Spacer-Blade Drive
6	9266934	2	Screw-HWH 5/16 X 1/2 Tf	12	114-4465	1	Decal-Service Aid

Seat Assembly (cont.)

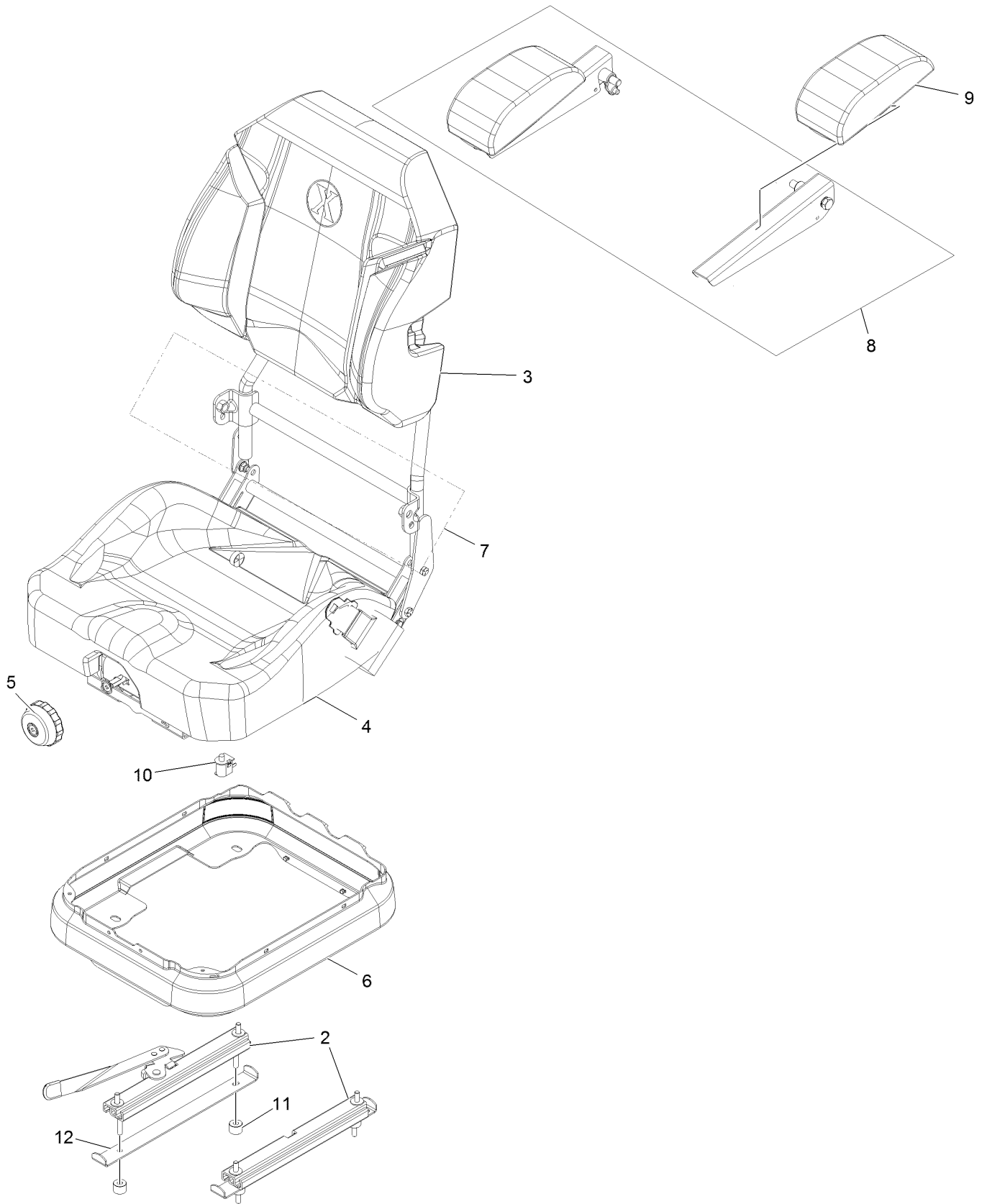

Seat Assembly (cont.) (continued)

<i>Ref.</i>	<i>Part Number</i>	<i>Qty.</i>	<i>Description</i>	<i>Ref.</i>	<i>Part Number</i>	<i>Qty.</i>	<i>Description</i>
2	116-8910	1	Seat Track Set	7	126-2061	1	Seat Belt Service Kit
3	116-8908	1	Cover-Back 311463Vn500	8	116-8906	1	Kit-Arm Rest Set
4	116-8909	1	Cover-Cushion 311464Vn500	9	116-8905	1	Kit-Arm Rest Pads
5	116-8911	1	Knob-Adjuster	10	82-2190	1	Switch
6	116-5659	1	Cover-Suspension Bellows	11	116-9329	4	Spacer
				12	126-9918-03	2	Stop, Seat

Fuel Tank Assembly

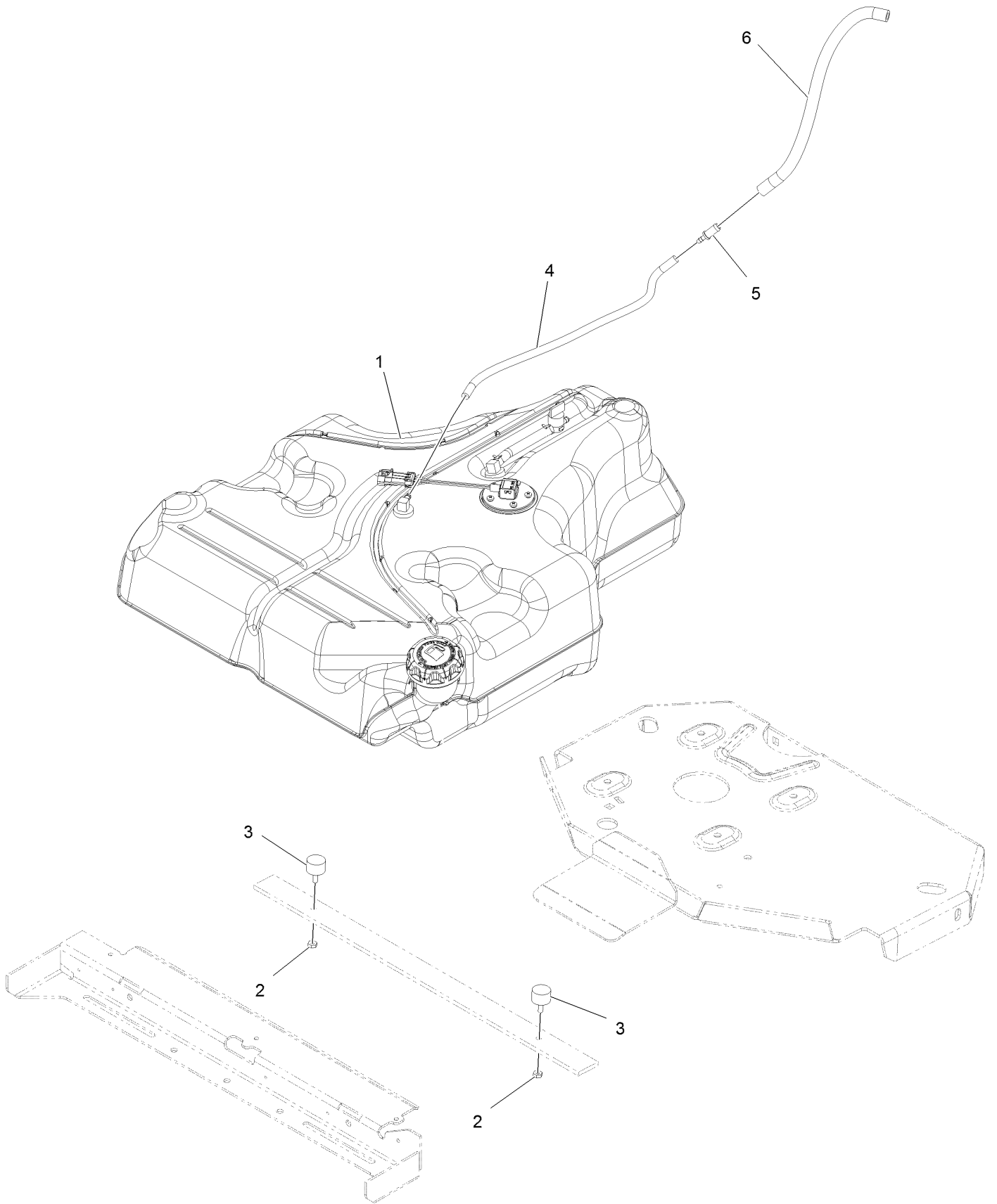

Fuel Tank Assembly (continued)

<i>Ref.</i>	<i>Part Number</i>	<i>Qty.</i>	<i>Description</i>	<i>Ref.</i>	<i>Part Number</i>	<i>Qty.</i>	<i>Description</i>
1	126-6493	1	Fuel Tank ASM	4	110-8751	1	Hose-Fuel
2	3218-1	2	Nut-Jam 1/4-20	5	98-2952	1	Fitting-Straight
3	116-6380	2	Bumper-Rubber (W/ Stud)	6	116-4344	1	Hose-Fuel

Fuel Tank Assembly No. 126-6493

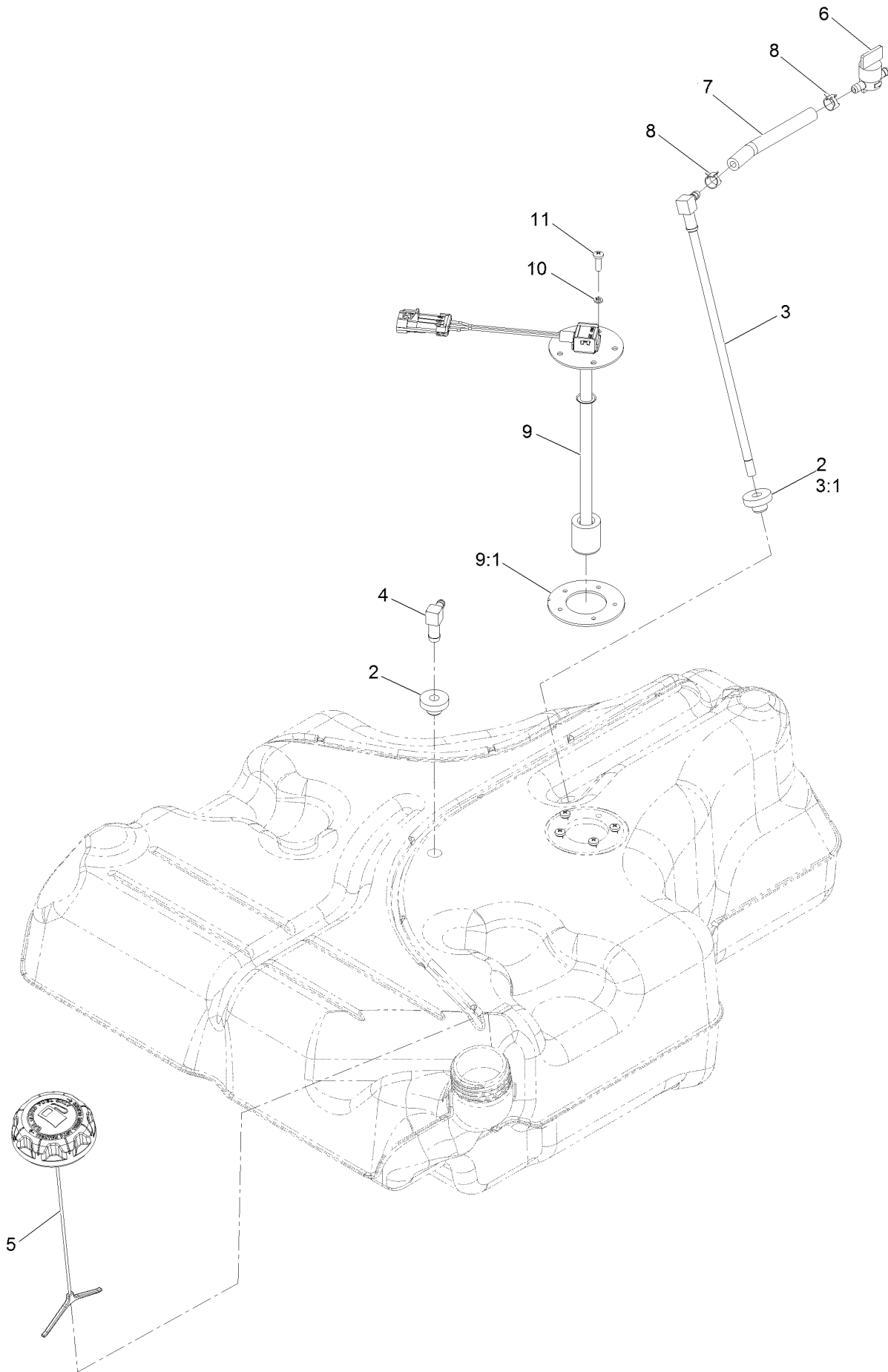

Fuel Tank Assembly No. 126-6493 (continued)

<i>Ref.</i>	<i>Part Number</i>	<i>Qty.</i>	<i>Description</i>	<i>Ref.</i>	<i>Part Number</i>	<i>Qty.</i>	<i>Description</i>
2	46-6560	2	Bushing	7	109-0650	1	Hose-Fuel
3	116-2459	1	Fuel Line Kit (With Grommet)	8	2412-98	2	Clamp-Hose
3:1	46-6560	1	Bushing	9	126-3949	1	Sender-Fuel Level W/Gasket 8 Gallon
4	116-2288	1	Fitting-90 Elbow	9:1	126-3950	1	Gasket-Sender
5	126-1789	1	Cap-Fuel, Ratcheting	10	3253-17	5	Washer-Lock 3/16
6	1-603770	1	Valve-Fuel	11	3290-500	5	Screw-PPH #10-24 X 5/8

Engine Assembly

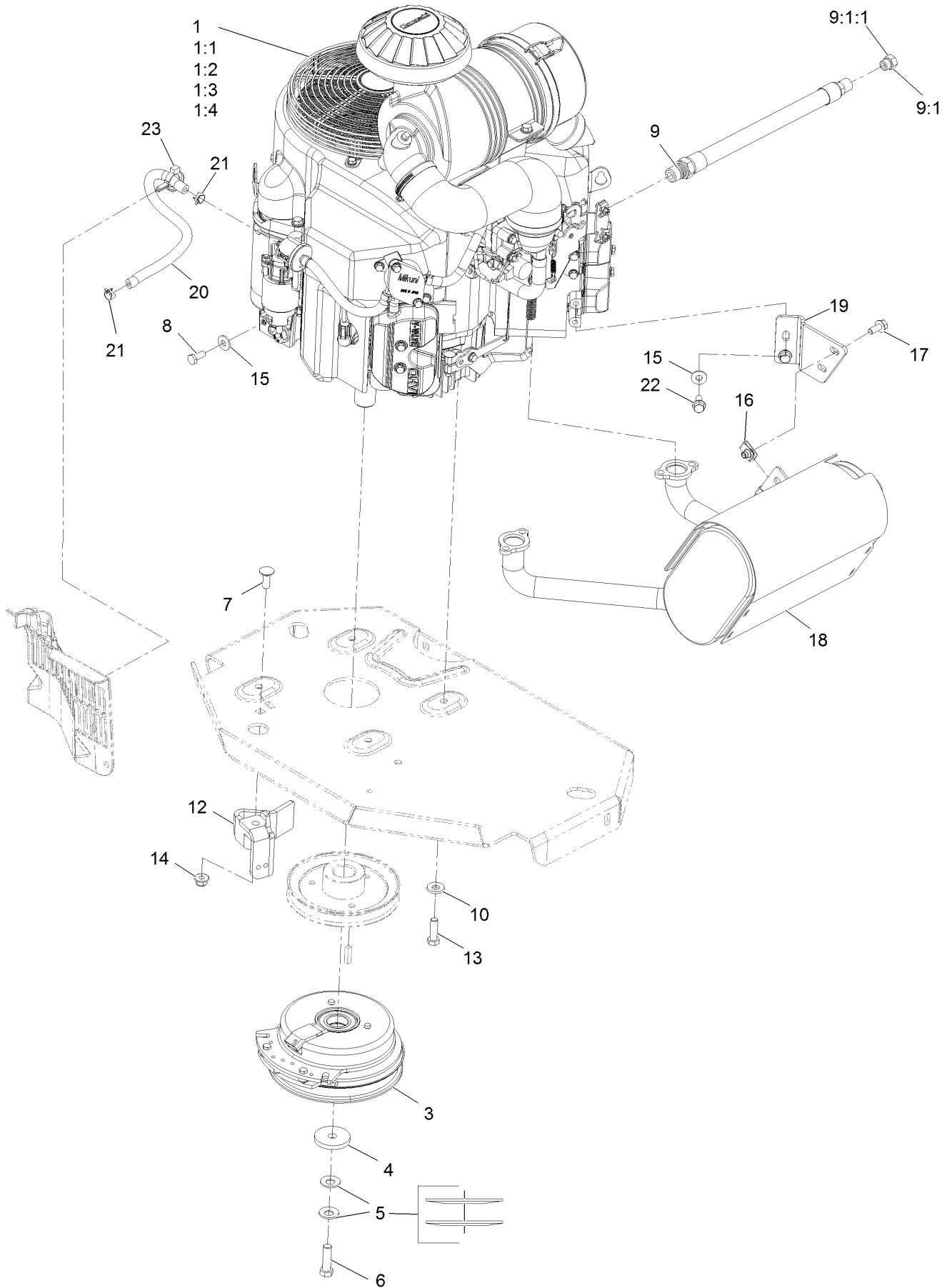

Engine Assembly (continued)

<i>Ref.</i>	<i>Part Number</i>	<i>Qty.</i>	<i>Description</i>	<i>Ref.</i>	<i>Part Number</i>	<i>Qty.</i>	<i>Description</i>
1		1	Engine-Kawasaki, Fx751V-S07-R ▲◆	9:1	353-508	1	Plug-W/O-Ring ●
1:1		1	Kawasaki 49065-2078 Engine Oil Filter ▲◆	9:1:1	237-42	1	O-Ring
1:2		1	Kawasaki 49019-7001 Fuel Filter ▲◆	10	98-5975	4	Washer-Spring Disc 3/8
1:3		1	Kawasaki 11013-7039 Safety Filter ▲◆	12	116-2612-01	1	Clutch-Anchor
1:4		1	Kawasaki 11013-7038 Air Filter ▲◆	13	323-7	4	Screw-HH 3/8-16 X 1 1/4
3	116-1620	1	Clutch Kit	14	104-8301	1	Nut-Nyloc 3/8-16 Flg
4	109-6919	1	Washer-Clutch	15	1-303334	3	Washer-Spring Disc 5/16
5	1-603610	2	Washer-Spring Disc 7/16	16	94-2413	2	Nut-U
6	109-9761	1	Screw-HH 7/16-20 X 1 1/2 W/Loctite □	17	3234-5	2	Screw-HH Flg 5/16-18 X 3/4
7	3231-22	1	Bolt-Carriage 3/8-16 X 1	18	116-1712	1	Muffler
8	33114-020	1	Screw-HH M8-1.25 X 20Mm	19	116-0203	1	Bracket-Muffler
9	116-4924	1	Asm-Hose Oil Drain W/Plug ■	20	109-0296	1	Hose-Fuel Line 15"
				21	2412-98	2	Clamp-Hose
				22	95-4184	2	Screw-HHF
				23	105-1853	1	Clamp-Hose

● Torque to 24-26 ft-lb

▲ Not serviced separately

□ Use Pro-Lock, Nut Type (P/N 1-840022, .5ml tube) on threads.

■ Torque to 23-29 ft-lb

◆ Obtain parts from www.kawpowerepc.com

Hydraulic Assembly

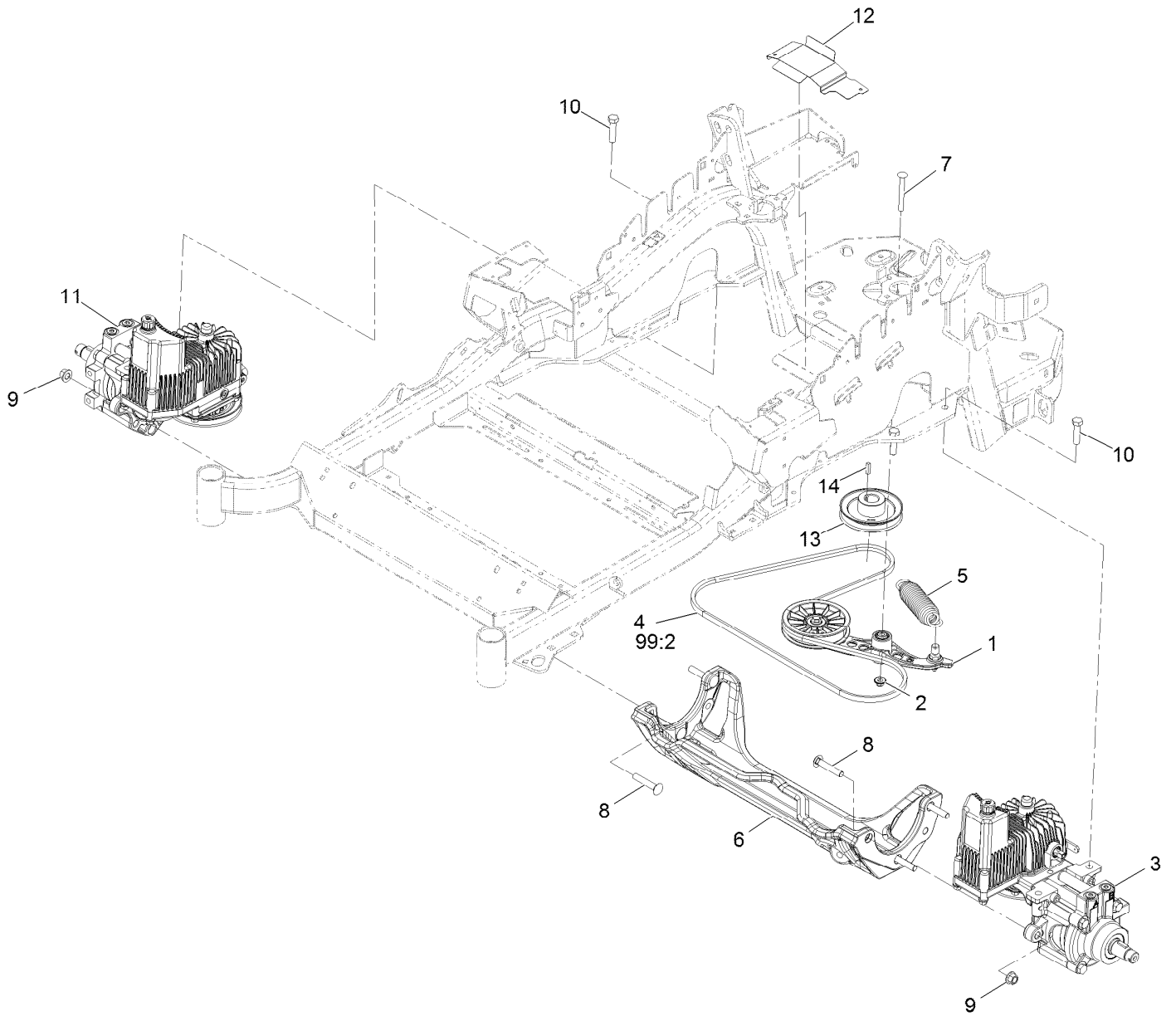

Hydraulic Assembly (continued)

<i>Ref.</i>	<i>Part Number</i>	<i>Qty.</i>	<i>Description</i>	<i>Ref.</i>	<i>Part Number</i>	<i>Qty.</i>	<i>Description</i>
1	116-1255	1	Pump Idler ASM	12	116-2999-01	1	Guard-Belt
2	109-6658	1	Nut-Nyloc 3/8-16 Flg	13	116-1946	1	Sheave-Pump, Drive
3	126-1327	1	LH Hydro ASM (12Cc No Fan)	14	1-807259	1	Key-Machine 1/4 X 1/4 X 1
4	116-1953	1	Belt-V	99	109-9828	1	Bottle-Oil, 32Oz Hydraulic ●
5	116-6317	1	Spring-Extension	99	116-0164	1	Filter-Hydro ●
6	116-7558	1	Cradle-Hydro	99	116-1218	1	Bottle,Oil 1 Gallon Hydraulic ●
7	116-1502	1	Bolt-Carriage Shoulder 3/8-16 X 3 1/2	99	116-3282	1	Kit,Hydro Service ●
8	126-0095	6	Screw-CARR	99:1	109-9828	4	Bottle-Oil, 32Oz Hydraulic ●
9	99-5107	6	Nut-Lock 1/2-13	99:2	116-1953	1	Belt-V
10	325-8	4	Screw-HH 1/2-13 X 1 1/4	99:3	116-0164	2	Filter-Hydro ●
11	126-1328	1	RH Hydro ASM (12Cc No Fan)				

● Not illustrated

LH Hydro Assembly No. 126-1327

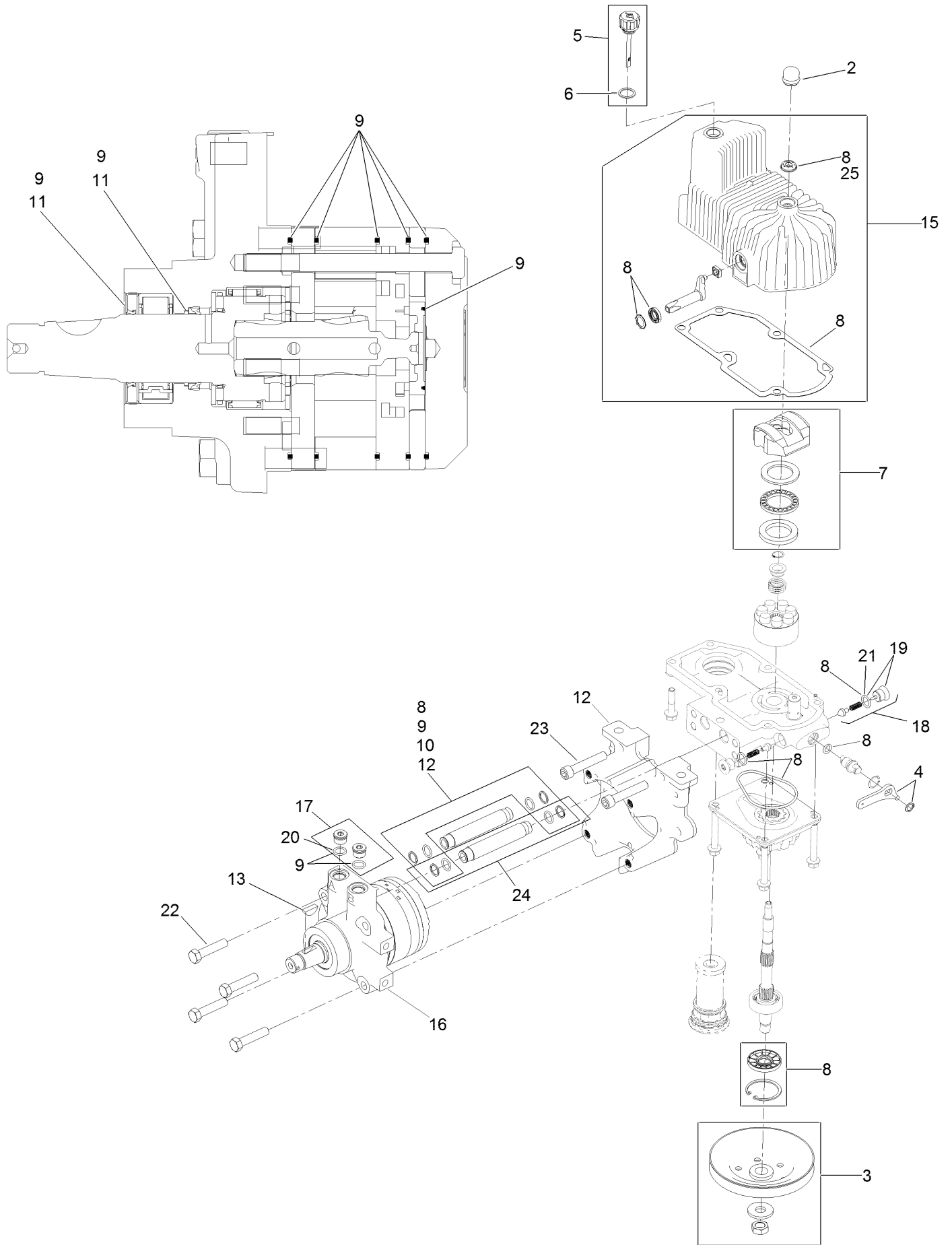

LH Hydro Assembly No. 126-1327 (continued)

<i>Ref.</i>	<i>Part Number</i>	<i>Qty.</i>	<i>Description</i>	<i>Ref.</i>	<i>Part Number</i>	<i>Qty.</i>	<i>Description</i>
2	116-3052	1	Cover-Shaft, Hydro	15	116-3287	1	Housing-LH
3	116-0234	1	Pulley Kit	16	116-8915	1	Motor-Hydraulic LH 240Cc
4	116-0235	1	Handle-Bypass Valve, Hydro	17	116-7901	1	Magnetic Plugs Service Kit
5	116-0236	1	Dipstick-Hydro W/Gasket	18	116-1630	2	Check Valve ASM
6	116-0237	1	Gasket-Dipstick, Hydro	19	116-1631	2	Plug-Check (W/O-Ring)
7	116-1367	1	Swash Block Kit	20	76-1900	2	O-Ring
8	116-1368	1	Pump Seal Kit	21	116-8662	2	O-Ring-Check Valve
9	116-1369	1	Motor Seal Kit	22	116-8974	4	Screw HH
10	116-1370	1	Tube Seal Kit	23	116-8975	2	Screw-HSH
11	116-1371	1	Output Shaft Seal Kit	24	116-9922	2	Hydraulic Tube Kit
12	116-5469	1	Nose Cup-Uht	25	126-7711	1	Seal-Fan Drive
13	3257-42	1	Key-Woodruff	99	116-4245	1	Puller-Pulley ●
				99	116-1373	1	Flow Test Kit ●

● Not illustrated

RH Hydro Assembly No. 126-1328

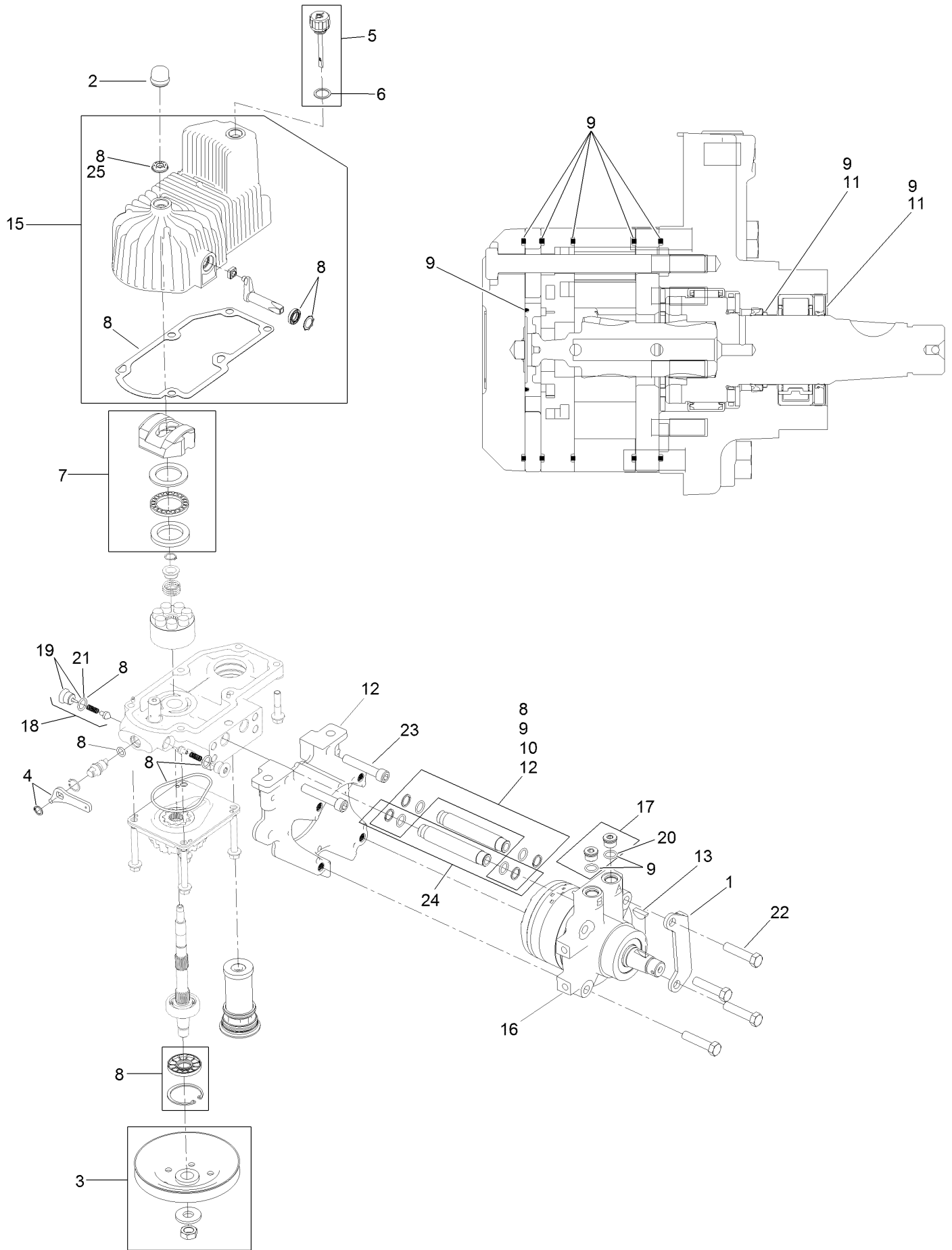

RH Hydro Assembly No. 126-1328 (continued)

<i>Ref.</i>	<i>Part Number</i>	<i>Qty.</i>	<i>Description</i>	<i>Ref.</i>	<i>Part Number</i>	<i>Qty.</i>	<i>Description</i>
1	116-9063	1	Mount-Shoe, Horse	15	116-3288	1	Housing-RH
2	116-3052	1	Cover-Shaft, Hydro	16	116-8916	1	Motor-Hydraulic RH 240Cc
3	116-0234	1	Pulley Kit	17	116-7901	1	Magnetic Plugs Service Kit
4	116-0235	1	Handle-Bypass Valve, Hydro	18	116-1630	2	Check Valve ASM
5	116-0236	1	Dipstick-Hydro W/Gasket	19	116-1631	2	Plug-Check (W/O-Ring)
6	116-0237	1	Gasket-Dipstick, Hydro	20	76-1900	2	O-Ring
7	116-1367	1	Swash Block Kit	21	116-8662	2	O-Ring-Check Valve
8	116-1368	1	Pump Seal Kit	22	116-8974	4	Screw HH
9	116-1369	1	Motor Seal Kit	23	116-8975	2	Screw-HSH
10	116-1370	1	Tube Seal Kit	24	116-9922	2	Hydraulic Tube Kit
11	116-1371	1	Output Shaft Seal Kit	25	126-7711	1	Seal-Fan Drive
12	116-5469	1	Nose Cup-Uht	99	116-4245	1	Puller-Pulley ●
13	3257-42	1	Key-Woodruff	99	116-1373	1	Flow Test Kit ●

● Not illustrated

Pump Idler Assembly No. 116-1255



Pump Idler Assembly No. 116-1255 (continued)

<i>Ref.</i>	<i>Part Number</i>	<i>Qty.</i>	<i>Description</i>	<i>Ref.</i>	<i>Part Number</i>	<i>Qty.</i>	<i>Description</i>
2	43-0940	1	Spacer	8	323-8	1	Screw-HH 3/8-16 X 1 1/2
3	103-3504	2	Bearing-Spherical	9	32120-10	2	Ring-Retaining
4	103-3505	1	Seal-Double Lip	10	302-19	1	Zerk-1/4-28 Str
5	103-3506	1	Seal-Single Lip	11	109-8076	1	Pulley-Idler
6	109-6658	1	Nut-Nyloc 3/8-16 Flg	12	132-4724	1	Pin-Spring Anchor
7	106-7159	2	O-Ring				

Electrical Assembly



Electrical Assembly (continued)

<i>Ref.</i>	<i>Part Number</i>	<i>Qty.</i>	<i>Description</i>	<i>Ref.</i>	<i>Part Number</i>	<i>Qty.</i>	<i>Description</i>
2	116-6009	1	Harness-Wire, Main ●	10	114-1218	1	Cable-Battery, Negative
2:1	103-3895	1	Diode	11	3234-5	2	Screw-HH Flg 5/16-18 X 3/4
2:2	218-578	1	Fuse-Blade, 10 Amp	12	104-8300	2	Nut-Nyloc 5/16-18 Flg
2:3	109355	1	Fuse-Blade, 15 Amp	13	1-303287	3	Tie-Cable 5 1/2 (Small)
2:4	109102	2	Fuse-Blade, 25 Amp	14	82-2190	1	Switch
2:5	116-0053	1	Cap-Plug	15	117-2221	1	Switch-Ignition
3	117-3882	1	Fuel/Hour Meter ASM	16	116-0124	1	Switch-PTO, 10 Amp
4	1-603511	1	Key-Ignition	17	104-2065	1	Screw-HWH #10-24 X 3/8
4	103-2106	1	Key-Exmark Logo	18	115-3864	1	Cable-Battery, Positive
5	110-6765	2	Switch	19	3256-24	1	Washer-3/8 Sae
6	116-0042-03	1	Strap-Tie Down, Battery	20	1-303335	2	Tie-Cable 7 15/16 (Large)
7	1-633651	2	Bolt-Holddown	22	109-2407	1	Insulator-Battery
8	1-543792	2	Wingnut-Nyloc 1/4-20	23	1-543393	1	Insulator-Solenoid
9	1-643275	1	Relay-12Vdc 40 Amp				

● Use dielectric grease on all unsealed connectors and terminals only. Do not apply in sealed connectors.

Notes:

Notes:

Notes:



MAXIMIZE THE PERFORMANCE OF YOUR EXMARK MACHINE.



EXMARK® PREMIUM ENGINE OIL

Exmark now offers a family of engine oil viscosities to perform well in any environment. Each viscosity has the same synthetic formulation to give you what you need in punishing conditions. We designed each grade to the highest quality, making it ideal even for diesel applications. Coupled with Exmark Premium Fuel Treatment, we have the performance products to make your machine hum.

EXMARK PREMIUM ENGINE OIL SAE 30/10W-30

- Meets zero shear requirements of a straight grade SAE 30 as well as the cold temp properties of a 10W-30.
- Most versatile oil in the industry.
- Superior corrosion protection over conventional oil - even in corrosive, humid environments.

EXMARK PREMIUM ENGINE OIL SAE 20W-50

- Perfect for your big block engine, or any application in severe service.
- Same full synthetic formulation as all other Exmark Premium viscosities.
- Also effective for use in severe service small block engines.

EXMARK PREMIUM ENGINE OIL SAE 10W-50

- Full synthetic formulation gives you peak performance. Don't settle for less.
- Wide span multi-grade combines easy starting in cold weather with maximum protection in high temperature operation.
- Reduce friction & wear over standard mineral formulations.

EXMARK PREMIUM ENGINE OIL SAE 0W-40

- The perfect choice for when the weather turns cold or unpredictable, and your Exmark UTV has to perform.
- Commercial quality for severe service.
- Advanced additive package helps prevent corrosion from long-term storage.

EXMARK PREMIUM ENGINE OIL UTV FORMULATION

- 4-cycle high-temp formulation.
- Heavier viscosity, full synthetic, perfect for your UTV.

EXMARK PREMIUM UTV EXTREME CONDITIONS GEAR OIL

- SAE 80W-90, designed to keep your UTV performing at its peak.
- Shear stable, hypoid gear lube.
- Includes a premium additive system to combat wear, oxidation, rust & corrosion.

Available from your local Exmark dealer. Find your closest dealer at exmark.com

EXMARK ACCESSORIES AND OPTIONS*

MID-MOUNT RIDING ACCESSORIES AND OPTIONS

CUSTOM RIDE SEAT SUSPENSION SYSTEM	OPERATOR CONTROLLED DISCHARGE
FULL SUSPENSION SEAT	SUN SHADE
DECK LIFT ASSIST KIT	TRASH CONTAINER
HITCH KIT	TURF STRIPER
LIGHT KIT	ULTRA VAC COLLECTION SYSTEM
12V POWER PORT	ULTRA VAC QUICK DISPOSAL SYSTEM
MICRO-MULCH SYSTEM	

OUT-FRONT RIDING ACCESSORIES AND OPTIONS

CUSTOM RIDE SEAT SUSPENSION SYSTEM	SNOW BLADE
DUAL-TAIL WHEEL	SNOWBLOWER
FLOOR PAN EXTENDER	SUN SHADE
HITCH KIT	TRASH CONTAINER
LIGHT KIT	ULTRA VAC COLLECTION SYSTEM
MICRO-MULCH SYSTEM	ULTRA VAC QUICK DISPOSAL SYSTEM
ROLL OVER PROTECTION SYSTEM (ROPS)	WEATHER CAB

WALK-BEHIND ACCESSORIES AND OPTIONS

GRASS CATCHER	TURF STRIPER
MICRO-MULCH SYSTEM	STANDON

*Some accessories and options not available for some models.

Place Model No. and Serial No.
Label Here (Included in the Literature
Pack) or Fill in Below

Model No. _____

Serial No. _____

Date Purchased _____

Engine Model No. and Spec. No. _____

Engine Serial No. (E/No) _____

© 2016 Exmark Mfg. Co., Inc.
Industrial Park Box 808
Beatrice, NE 68310
All Rights Reserved

Part No. 4503-141 Rev. A
(402) 223-6375
Fax (402) 223-5489
Printed in the USA.

