

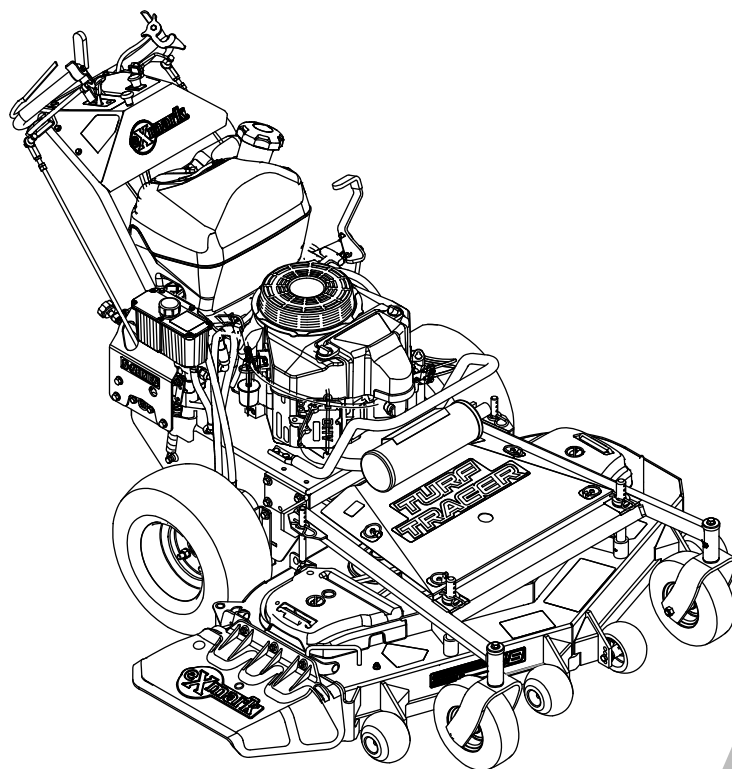

TURF TRACER S-SERIES

Model No. TTS481GKA48300—Serial No. 40000000 and Up

Picture below may not reflect actual product.



Parts Manual

Part No. 4502-979 Rev. A

Ordering Replacement Parts

To order replacement parts, please supply the part number, the quantity, and the description of each part desired.

Understanding Reference Numbers

Each identified part in an illustration has a reference number. The reference number for a part also appears in the parts list, along with other information about the part.

This catalog uses two special reference number formats, one to indicate parts in a service assembly and another to indicate the quantity of a given part in an illustration.

Service Assembly Reference Numbers

Parts in service assemblies have reference numbers in the form a:b. The a represents the reference number of the entire service assembly and the b represents a sequential number unique to each part within the service assembly.

For example, a wheel assembly might be identified by reference number 6, the tire by 6:1, the valve by 6:2, and the wheel by 6:3. When you order the assembly identified by reference number 6, you receive all parts identified by reference numbers 6:1, 6:2, and 6:3. However, you may also order any part individually. Reference numbers of this type appear in illustration and in parts lists.

Reference Numbers Indicating Quantity

In an illustration, if a reference number indicates more than one part, the reference number has the form nX y. The n represents the quantity of the part, the X is the multiplication symbol, and the y represents the reference number.

For example, in an illustration, the reference number 2X 37 means that two of the parts identified by reference number 37 are indicated.

Touch Up Paint

Exmark black touch up spray paint – gloss black.

Exmark red touch up paint (spray paint – P/N 1-850337 - .6 oz liquid bottle – P/N 103-9140).



If your Exmark dealer does not have the Exmark part in stock, Exmark will get the parts to the dealer the next business day or the part will be FREE Guaranteed!! (Some restrictions apply. See your participating Exmark Dealer for details.)

Contents

Complete Deck Assembly.....	4
Deck Assembly.....	6
Deck W/Decals Assembly No. 126-0781.....	8
Deck Idler Assembly No. 126-2314.....	10
Main Frame Assembly.....	12
Engine Deck.....	14
Handle Assembly.....	16
Controls Assembly.....	18
Fuel Assembly.....	20
Engine Assembly.....	22
Ground Drive Assembly.....	24
Pump Idler Assembly No. 126-0615.....	26
Electrical Assembly.....	28

Complete Deck Assembly

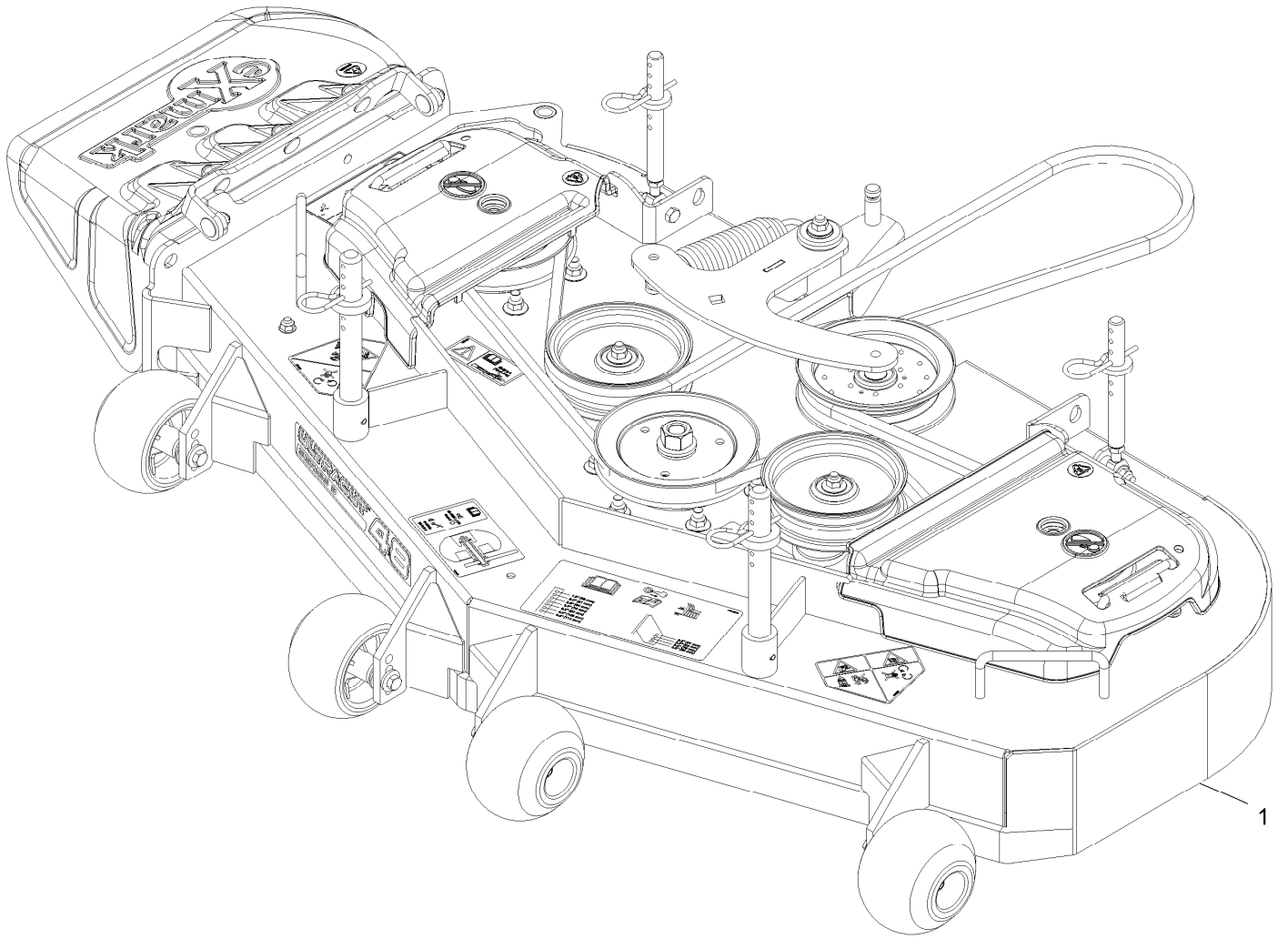

Complete Deck Assembly (continued)

<i>Ref.</i>	<i>Part Number</i>	<i>Qty.</i>	<i>Description</i>
1	126-1909	1	ASM-Complete Deck 48

Deck Assembly

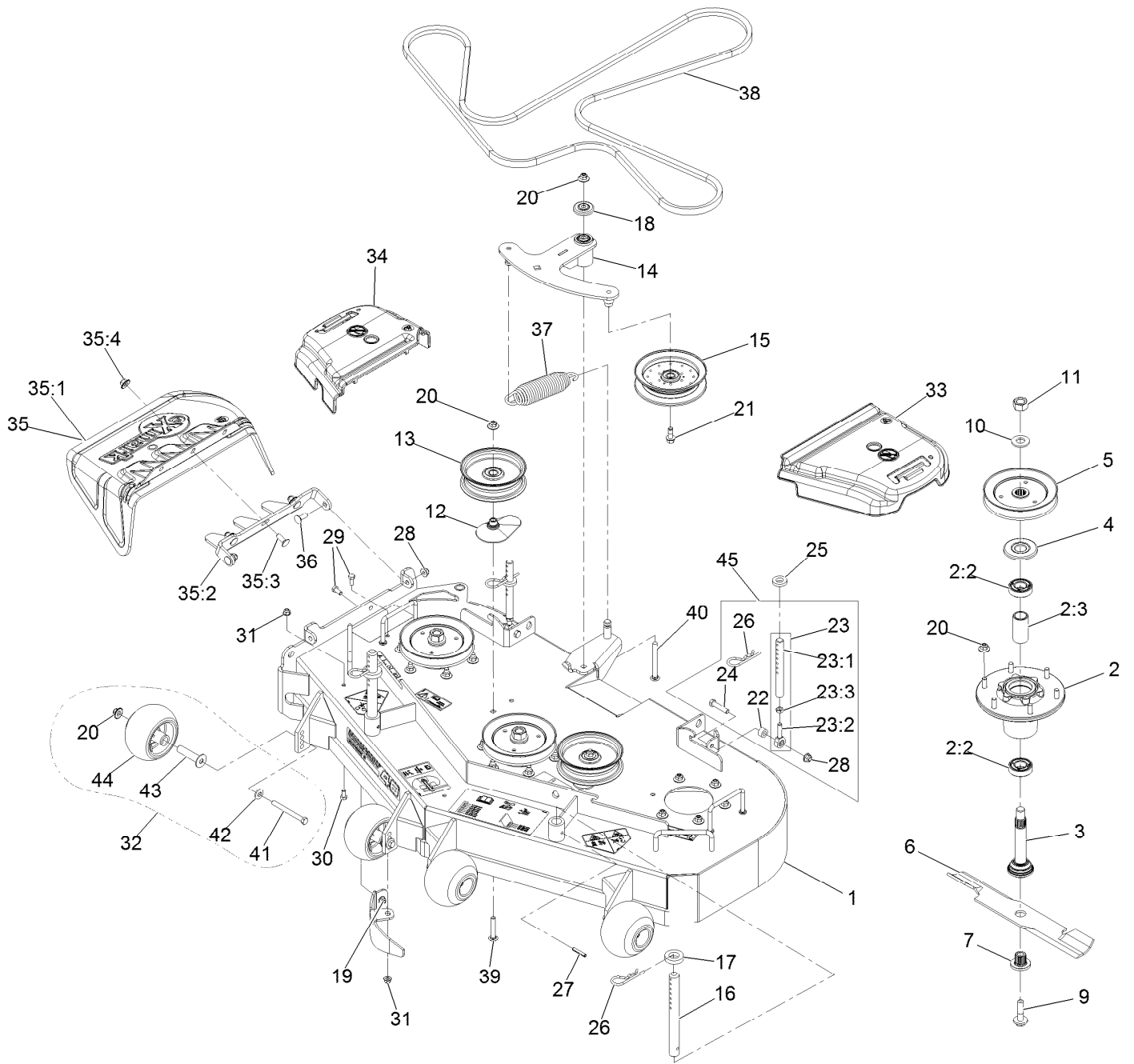

Deck Assembly (continued)

<i>Ref.</i>	<i>Part Number</i>	<i>Qty.</i>	<i>Description</i>	<i>Ref.</i>	<i>Part Number</i>	<i>Qty.</i>	<i>Description</i>
1	126-0781	1	ASM, Deck 48" W/Decals	23:1	1-413525	1	Link, Rear Deck Support
2	116-3344	3	ASM-Cutter Hsg With Bearings	23:2	1-613204	1	Balljoint
2:2	116-0720	2	Bearing-Ball	23:3	3220-3	1	Nut-Jam 3/8-24
2:3	116-3312	1	Spacer-Bearing	24	323-9	2	Screw-HH 3/8-16 X 1 3/4
3	116-3342	3	ASM-Spindle And Seal ◆	25	1-323539	2	Spacer-Blade Drive
4	116-1286	3	Guard,Bearing Top .989	26	1-806009	4	Hairpin-Cotter #206
5	116-0674	3	Sheave,Blade Drive 5.90	27	1-806332	2	Rollpin 1/4 X 1 1/2
6	103-6381	3	Blade, Solid	28	104-8301	4	Nut-Nyloc 3/8-16 Flg
6	103-6386	3	Blade, Low Lift	29	322-3	2	Screw-HH 5/16-18 X 3/4
6	103-6391	3	Blade, Mulching ▲	30	322-2	1	Screw-HH 5/16-18 X 5/8
6	103-6401	3	Blade-Notched	31	104-8300	3	Nut-Nyloc 5/16-18 Flg
6	116-5177	3	Blade-Extreme 2, 16.25"	32	116-9981	4	Kit, Anti-Scalp Roller
7	103-3037	3	Bushing, Splined	33	109-6936	1	Cover-Belt, LH
9	109-9220	3	Screw-Sems 1/2-20 X 2.19 ● □	34	109-6935	1	Cover-Belt, RH
10	103-2802	3	Washer-Spring Disc 3/4	35	126-0959	1	ASM, Discharge Chute
11	116-7306	3	Nut-Hex ■	35:1	109-2738	1	Chute, Discharge
12	109-2872	2	Spacer-Pulley	35:2	126-0958-01	1	Bracket, Discharge Chute
13	116-4669	2	Idler-Pulley, Flat	35:3	3231-22	3	Bolt-Carriage 3/8-16 X 1
14	126-2314	1	ASM, Deck Idler	35:4	109-6658	3	Nut-Nyloc 3/8-16 Flg
15	116-4668	1	Idler-Pulley, Flanged	36	3231-22	2	Bolt-Carriage 3/8-16 X 1
16	1-603001	2	Rod, Deck Support	37	116-6317	1	Spring-Extension
17	1-413425	2	Spacer-Deck Support	38	126-0783	1	Belt, Deck
18	103-2916	1	Guard-Top	39	3231-40	2	Bolt-Carriage 3/8-16 X 2 1/4
19	126-2782-01	1	Baffle, Dogleg	40	3231-24	1	Bolt-Carriage 3/8-16 X 3 3/4
20	109-6658	25	Nut-Nyloc 3/8-16 Flg	41	116-9362	4	Screw-HH 3/8-16 X 3 3/4 GR 8
21	126-1680	1	Screw-Hfh	42	98-5975	4	Washer-Spring Disc 3/8
22	1-603050	2	Spacer	43	116-8131	4	Axle, Roller
23	1-414521	2	Link Assy	44	103-8415	4	Roller-Anti-Scalp
				45	1-411532	2	Kit, Support Link W/Pin

● Torque to 50-60 ft-lb

■ Torque to 130-160 ft-lb

▲ Requires installation of mulch kit for proper mulching. See your Exmark dealer for details.

◆ Apply Mobil HTS grease (P/N 103-5217 1.5 oz packet) (or a food-grade anti-seize). See operator s manual for locations.

□ Apply lubricant to threads as needed to prevent seizing. Copper based anti-seize preferable. Grease is an acceptable substitute.

Deck W/Decals Assembly No. 126-0781

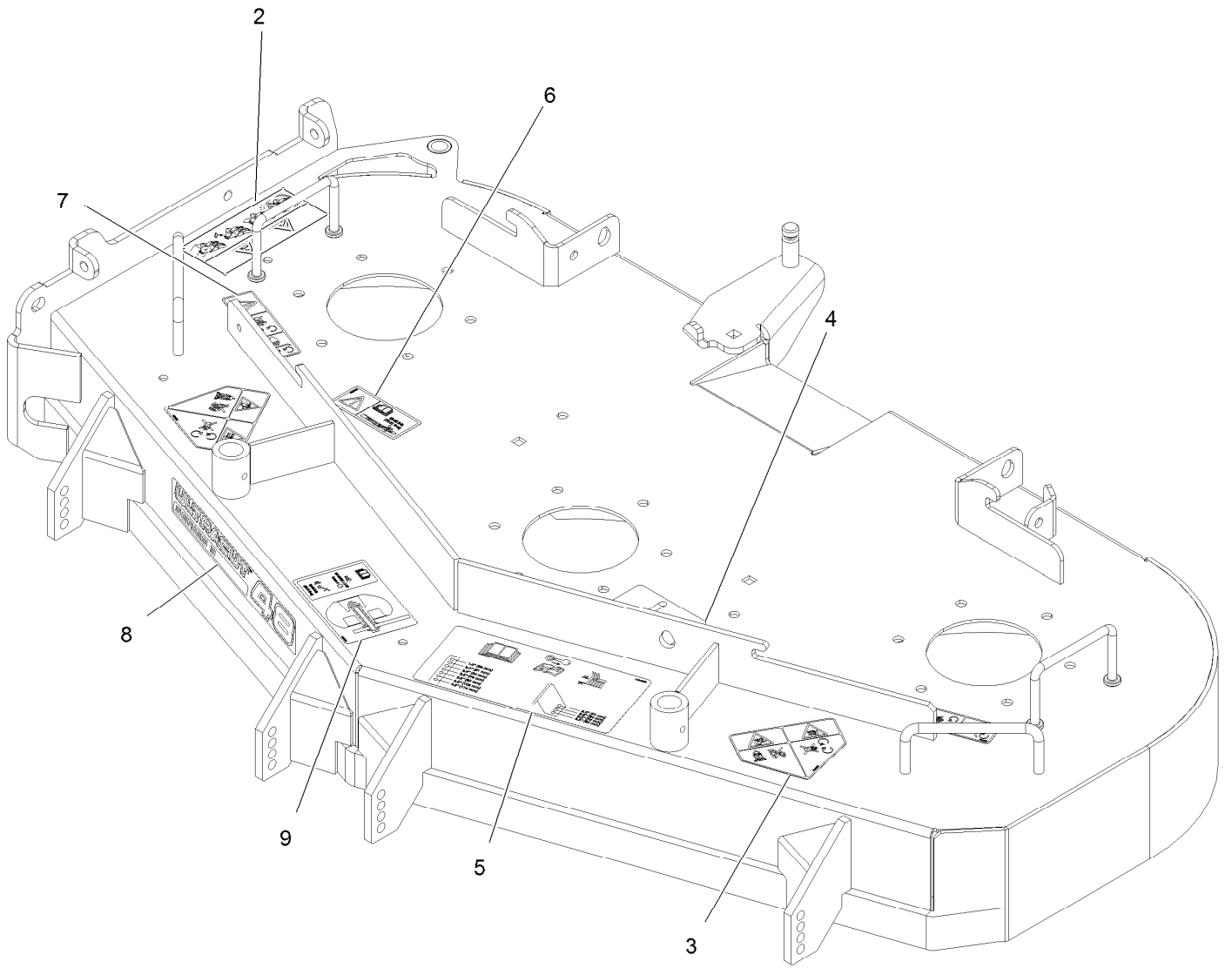

Deck W/Decals Assembly No. 126-0781 (continued)

<i>Ref.</i>	<i>Part Number</i>	<i>Qty.</i>	<i>Description</i>	<i>Ref.</i>	<i>Part Number</i>	<i>Qty.</i>	<i>Description</i>
2	114-3489	1	Decal-Warning, Bagger	6	116-8283	1	Decal-Bolt Torque
3	112-8760	2	Decal-Danger	7	112-9028	3	Decal-Missing, Cover
4	116-8727	1	Decal-Belt Routing	8	126-6746	1	Decal-Ultracut 48 Series 3
5	116-8278	1	Decal-Anti-Scalp	9	126-0898	1	Decal-Roller Mounting

Deck Idler Assembly No. 126-2314

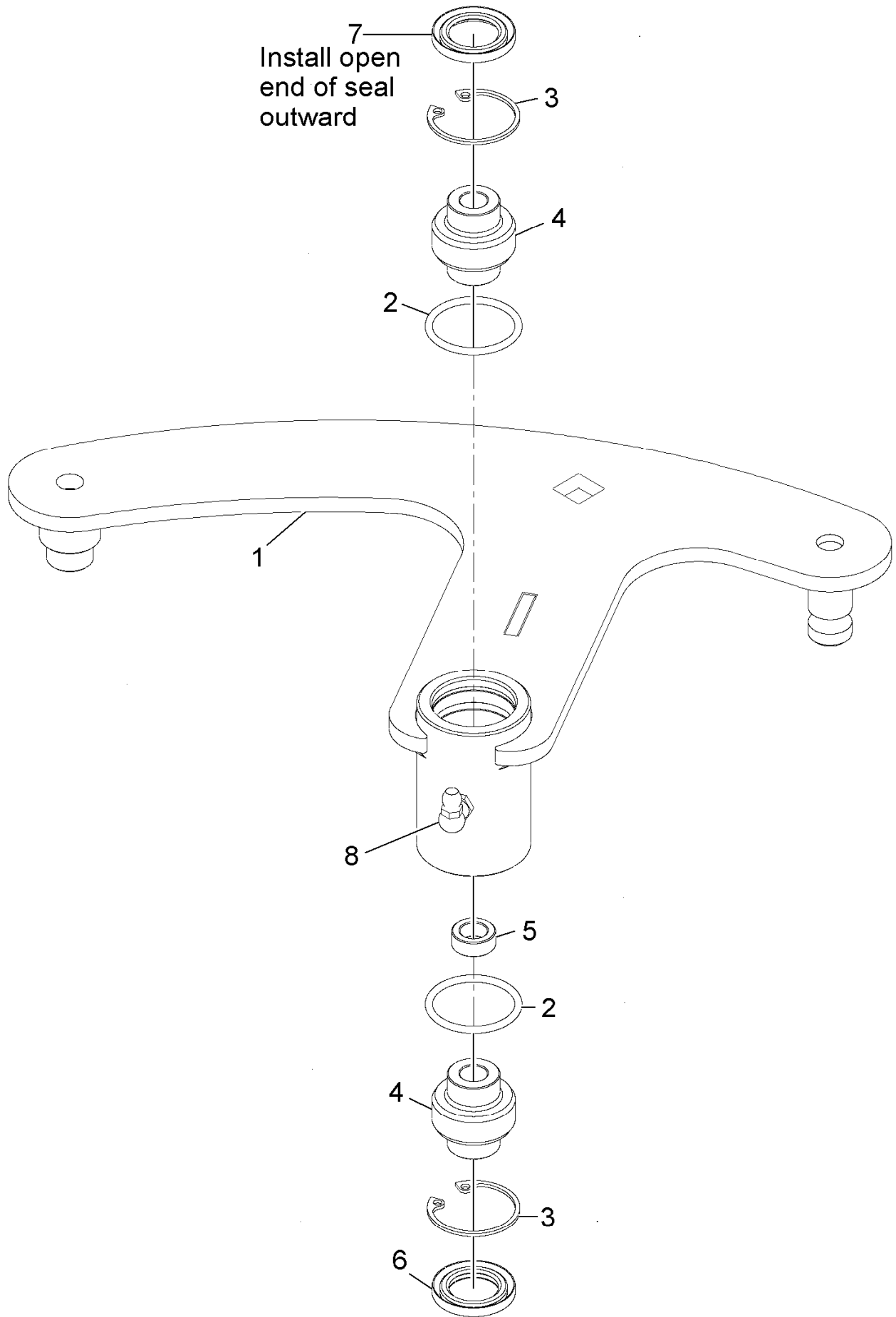

Deck Idler Assembly No. 126-2314 (continued)

<i>Ref.</i>	<i>Part Number</i>	<i>Qty.</i>	<i>Description</i>	<i>Ref.</i>	<i>Part Number</i>	<i>Qty.</i>	<i>Description</i>
1		1	Weld, Idler Arm ●	5	103-5677	1	Spacer
2	106-7159	2	O-Ring	6	103-3505	1	Seal-Double Lip
3	32120-10	2	Ring-Snap	7	103-3506	1	Seal-Lip, Single
4	103-3504	2	Bearing-Spherical	8	302-40	1	Fitting-Grease, 90 DEG

● Not serviced separately

Main Frame Assembly

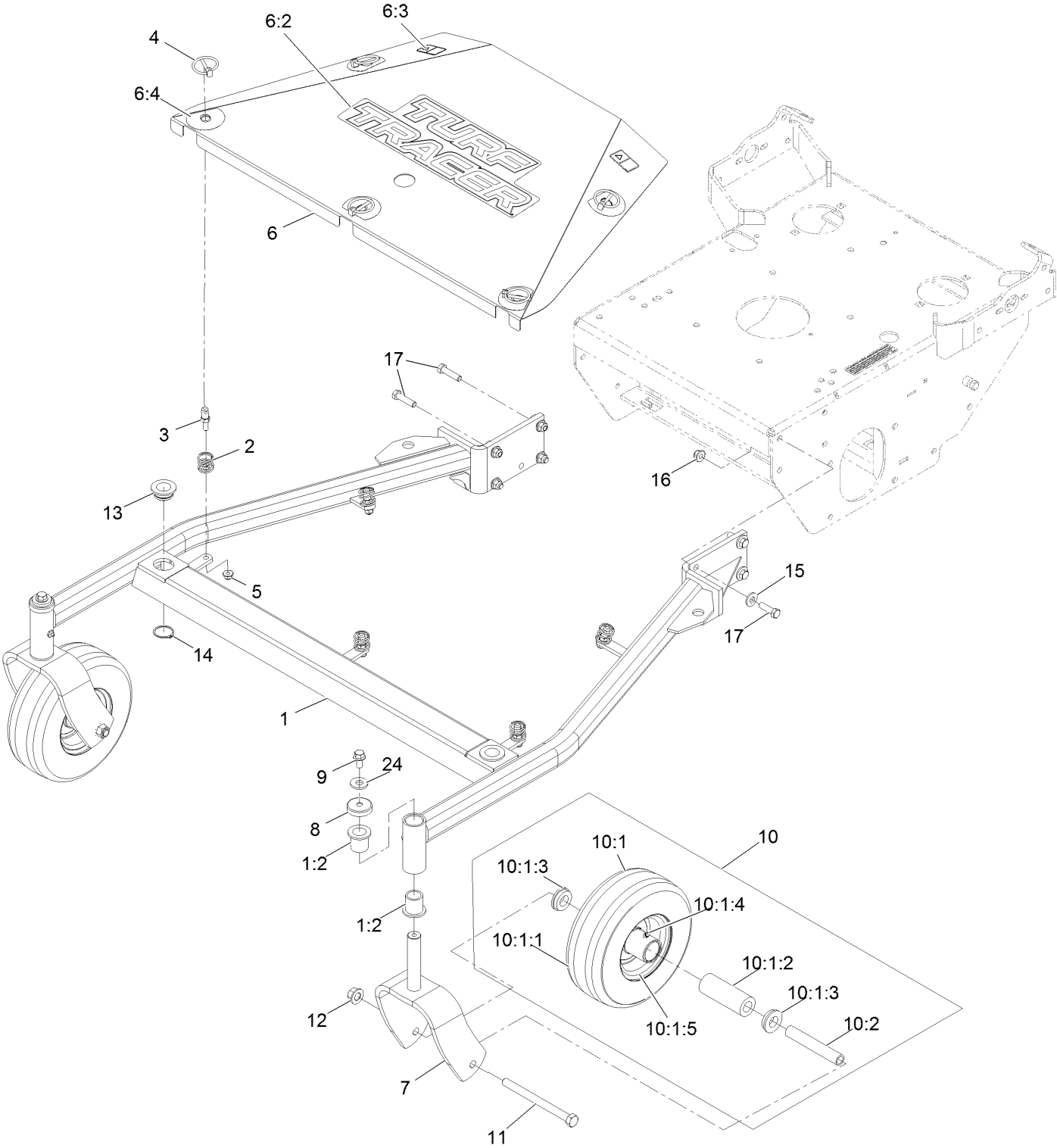

Main Frame Assembly (continued)

<i>Ref.</i>	<i>Part Number</i>	<i>Qty.</i>	<i>Description</i>	<i>Ref.</i>	<i>Part Number</i>	<i>Qty.</i>	<i>Description</i>
1	126-1514	1	ASM, Frame W/ Bushings, 48	10:1		1	Wheel And Tire ASM ●
1:2	1-303514	4	Bearing-Flanged	10:1:1		1	Tire ●
2	126-1503	4	Spring	10:1:2	1-513809	1	Bearing
3	126-1504	4	Pin, Spring	10:1:3	1-513810	2	Bushing-Flanged
4	92-1298	4	Pin-Lynch	10:1:4	302-61	1	Zerk-45° 1/4-28
5	104-8300	4	Nut-Nyloc 5/16-18 Flg	10:1:5		1	Wheel ●
6	126-1517	1	ASM, Shield W/ Decals, 48	10:2	1-513547	1	Spacer
6:2	126-6892	1	Decal-Turf Tracer	11	325-20	2	Screw-HH 1/2-13 X 6
6:3	106-5517	2	Decal-Warning	12	99-5107	2	Nut-Lock 1/2-13
6:4	126-1692	4	Decal-Scratch Cover	13	1-513336	2	Bushing-Deck
7	116-7941-01	2	Fork, Caster [red]	14	32120-33	2	Ring-Retaining
8	126-1425	2	Cap, Dust	15	98-5975	8	Washer-Spring Disc 3/8
9	110-1718	2	Screw-Hex Flange 3/8-16 X 3/4	16	104-8301	8	Nut-Nyloc 3/8-16 Flg
10	1-513547	2	Spacer	17	323-7	8	Screw-HH 3/8-16 X 1 1/4
10	103-2171	2	Kit,Semi-Pneumatic Wheel Replacement	24	1-373034	2	Washer

● Not serviced separately

Engine Deck

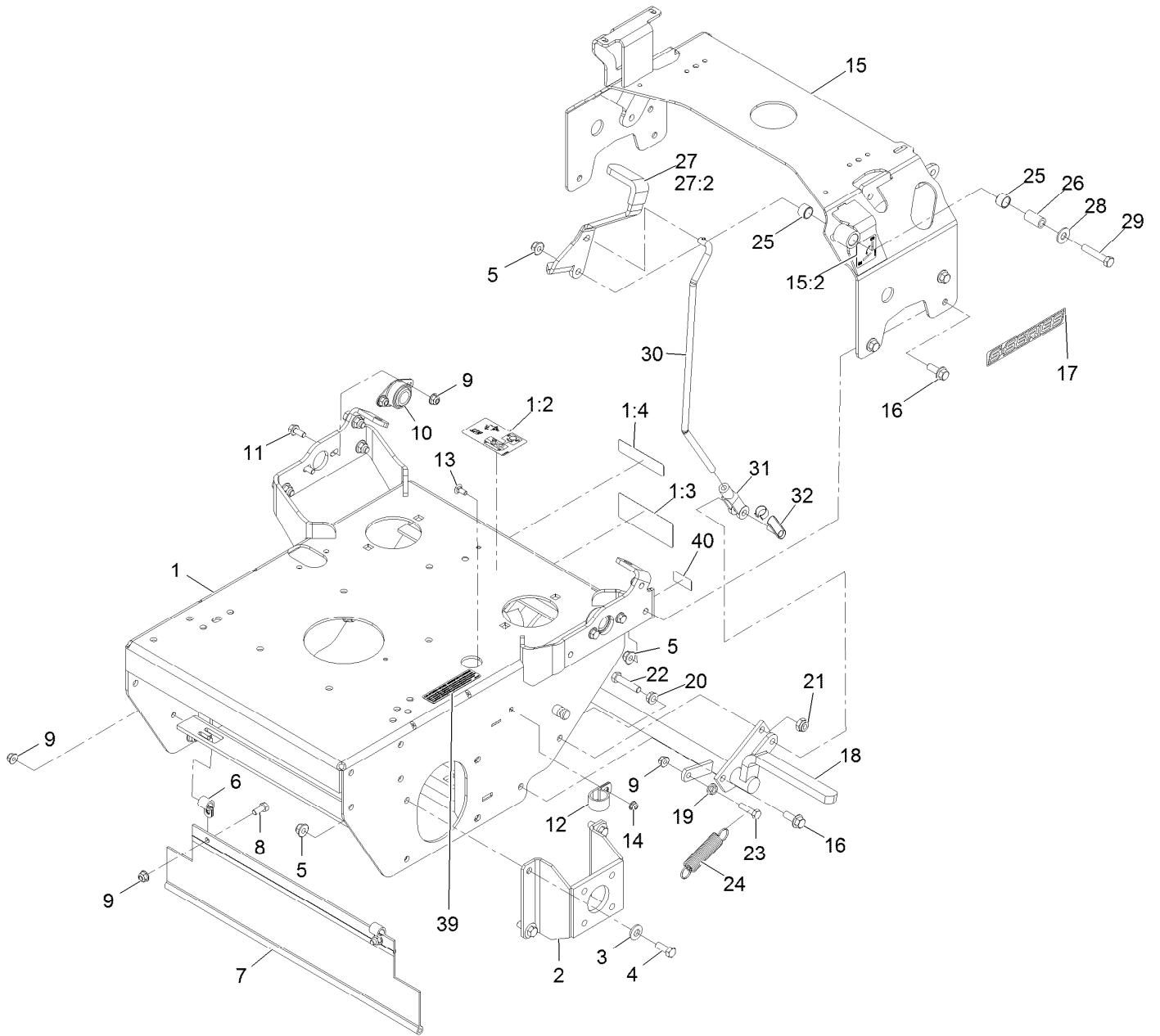

Engine Deck (continued)

<i>Ref.</i>	<i>Part Number</i>	<i>Qty.</i>	<i>Description</i>	<i>Ref.</i>	<i>Part Number</i>	<i>Qty.</i>	<i>Description</i>
1	126-1238	1	ASM, Engine Deck W/ Decals	16	3234-42	9	Screw HHF 3/8-16 X 1
1:2	116-8253	1	Decal-Drive Release	17	126-6572	2	Decal-S-Series
1:3	126-1400	1	Decal-Warning, Sulky	18	116-9964	1	Brake
1:4	98-1977	1	Decal-Warning	19	32128-20	1	Nut-Whizlock 5/16-18
2	1-412082-01	2	Mount-Wheel Motor	20	3290-357	1	Nut-Whizlock 3/8-16
3	98-5975	8	Washer-Spring Disc 3/8	21	3296-44	1	Nut-Lock, NI
4	323-6	8	Screw-HH 3/8-16 X 1	22	323-9	1	Screw-HH 3/8-16 X 1 3/4
5	104-8301	18	Nut-Nyloc 3/8-16 Flg	23	322-6	1	Screw-HH 5/16-18 X 1 1/4
6	1-413510	2	Clip-Loom	24	1-323161	1	Spring
7	103-2056	1	Shield-Drag	25	1-413347	2	Sleeve-Bushing
8	322-3	2	Screw-HH 5/16-18 X 3/4	26	1-413344	1	Bushing-Pivot
9	104-8300	7	Nut-Nyloc 5/16-18 Flg	27	126-2180	1	ASM, Brake Lever W/ Grip
10	1-633102	2	Bearing-Flanged	27:2	1-303020	1	Grip-Lever
11	3234-47	4	Screw-HH Flg 5/16-18 X 3/4	28	3256-4	1	Washer-3/8 Std
12	1-643312	1	Clip-Loom	29	323-10	1	Screw-HH 3/8-16 X 2
13	3229-11	1	Bolt-Carriage 1/4-20 X 5/8	30	116-9959	1	Linkage, Brake
14	104-7201	1	Nut-Nyloc 1/4-20 Flg	31	1-633131	1	Yoke-Linkage, Brake
15	126-2181	1	ASM, Tank Support W/ Decal	32	103-2399	1	Pin-Clevis Spring 3/8
15:2	116-5988	1	Decal-Park Brake, CE	39	117-2718	1	Decal-Arrester, Spark
				40	126-4345	1	Decal-Patent

Handle Assembly

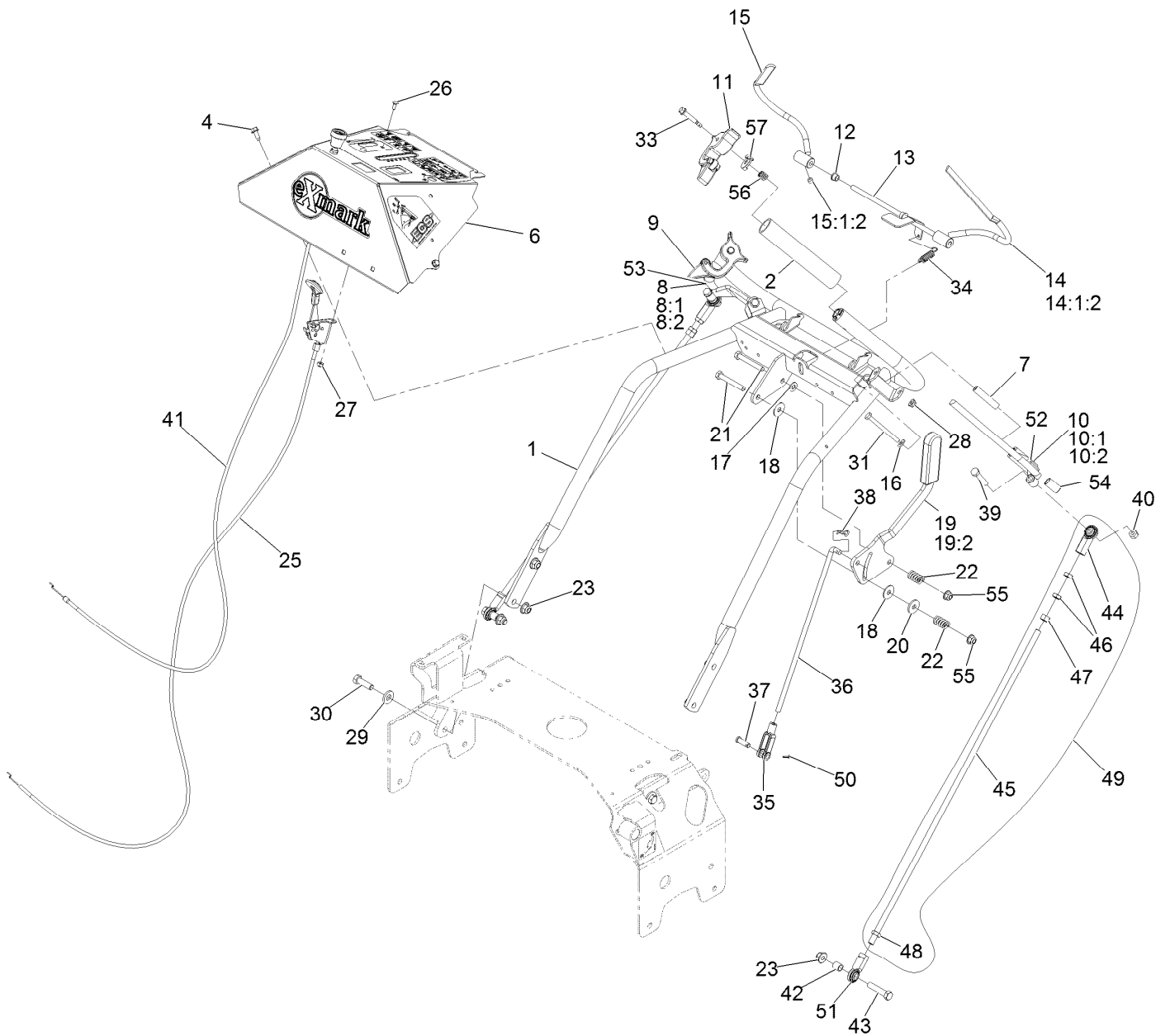

Handle Assembly (continued)

<i>Ref.</i>	<i>Part Number</i>	<i>Qty.</i>	<i>Description</i>	<i>Ref.</i>	<i>Part Number</i>	<i>Qty.</i>	<i>Description</i>
1	126-2642-03	1	Weld, Handle	27	3296-2	2	Nut-Nyloc #10-24
2	103-0815	2	Grip-BAR, Handle	28	104-7201	2	Nut-Nyloc 1/4-20 Flg
4	32144-10	2	Screw-HWH 1/4-20 X .62	29	98-5975	4	Washer-Spring Disc 3/8
6	126-4706	1	ASM, Console W/ Decals	30	323-7	4	Screw-HH 3/8-16 X 1 1/4
7	103-0027	2	Bushing-Lever, Drive	31	321-14	2	Screw-HH 1/4-20 X 2 3/4
8	103-2513	1	Asm, Drive Lever RH	33	126-2931	2	Screw-Shoulder
8:1	116-4082	1	Wld,RH Drive Lever	34	1-303363	1	Spring-Extension
8:2	126-9366	2	Bushing, Sleeve	35	1-303105	1	Yoke-Adjustable
9	103-1371	1	Thumb Latch Asm RH	36	1-413225	1	Rod, Speed Control
10	103-2514	1	Asm, Drive Lever LH	37	1-808280	1	Pin-Clevis 5/16 X 1 49/64
10:1	116-4081	1	Wld,LH Drive Lever	38	1-806003	1	Hairpin-Cotter
10:2	126-9366	2	Bushing, Sleeve	39	322-9	2	Screw-HH 5/16-18 X 1 3/4
11	103-1372	1	Thumb Latch Asm LH	40	3296-29	2	Nut-Nyloc 5/16-18
12	1-303365	2	Bushing-Nylon	41	126-2107	1	Cable, Choke
13	103-0769-03	1	Rod Weldment, OPC	42	103-1166	2	Spacer-Tube, Pump Link
14	116-4079	1	Wld,LH OPC Lever ■	43	323-9	2	Screw-HH 3/8-16 X 1 3/4
14:1:2	1-803322	1	Setscrew-5/16-24 X 5/16 ●	44	103-2463	2	Balljoint
15	116-4080	1	Wld,RH OPC Lever ■	45	103-1148	2	Rod,Drive Lever
15:1:2	1-803322	1	Setscrew-5/16-24 X 5/16 ●	46	3220-3	4	Nut-Jam 3/8-24
16	3256-22	2	Washer-1/4 SAE	47	3219-3	2	Nut-Hex 3/8-24
17	3256-23	1	Washer-5/16 SAE	48	3220-16	2	Nut-Jam 3/8-24 LH
18	1-323244	2	Washer-Friction	49	116-3414	2	Drive Link ASM
19	126-0148	1	Lever, Shift W/Grip	50	3272-5	1	Pin-Cotter 3/32 X 1/2
19:2	103-5994	1	Grip-Handle, Steering	51	103-1167	2	Joint-Ball End
20	1-603716	1	Washer-Friction Disc	52	116-4081	1	Wld,LH Drive Lever
21	322-11	2	Screw-HH 5/16-18 X 2 1/4	53	116-4082	1	Wld,RH Drive Lever
22	1-323245	2	Spring-Compression	54	126-9366	4	Bushing, Sleeve
23	104-8301	6	Nut-Nyloc 3/8-16 Flg	55	104-8300	2	Nut-Nyloc 5/16-18 Flg
25	109-3958	1	Control-Throttle	56	1-633349	2	Spring-Compression
26	1-807513	2	Bolt-Carriage #10-24 X 1/2	57	126-2921	2	Latch, Ecs

● Use Pro-Lock, Nut Type (P/N 1-840022, .5ml tube) on threads.

■ Use Pro-Lock retaining type, Part no. 1-840023 (.5cc tube) on inside of bore of OPC hub.

Controls Assembly



Controls Assembly (continued)

<i>Ref.</i>	<i>Part Number</i>	<i>Qty.</i>	<i>Description</i>	<i>Ref.</i>	<i>Part Number</i>	<i>Qty.</i>	<i>Description</i>
1	116-9975	1	Weld, Motion Control, Rt	15	1-808280	2	Pin-Clevis 5/16 X 1 49/64
2	116-9974	1	Weld, Motion Control, Lt	16	1-806003	2	Hairpin-Cotter
3	1-803022	2	Setscrew-5/16-18 X 5/8	17	1-613089	2	Tab-Spring, Extension
4	126-2982-01	1	Weld, Speed Control	18	1-603693	2	Spring
5	1-603735	2	Bushing-Flanged	19	126-0610	2	Pin, Motion Control
6	103-0265	2	Spring, Neutral Return	20	1-603676	2	Swivel-Adjustable, Short
7	1-603737	2	Bolt-Neutral Return	21	1-413350	2	Link-Control, Speed
8	3256-23	9	Washer-5/16 SAE	22	3272-5	2	Pin-Cotter 3/32 X 1/2
9	3219-2	7	Nut-Hex 5/16-24	23	1-323245	1	Spring-Compression
10	3220-2	2	Nut-Jam 5/16-24	24	1-603903	1	Spacer
11	104-8300	6	Nut-Nyloc 5/16-18 Flg	25	103-3060	1	Knob-Tracking
12	32128-20	2	Nut-Whizlock 5/16-18	27	1-809056	2	Screw-Sh 5/16-18 X 1 3/8
13	322-5	2	Screw-HH 5/16-18 X 1	28	116-7918	1	Decal-Tracking Adjustment
14	1-303105	2	Yoke-Adjustable	29	302-19	2	Zerk-1/4-28 Str

Fuel Assembly

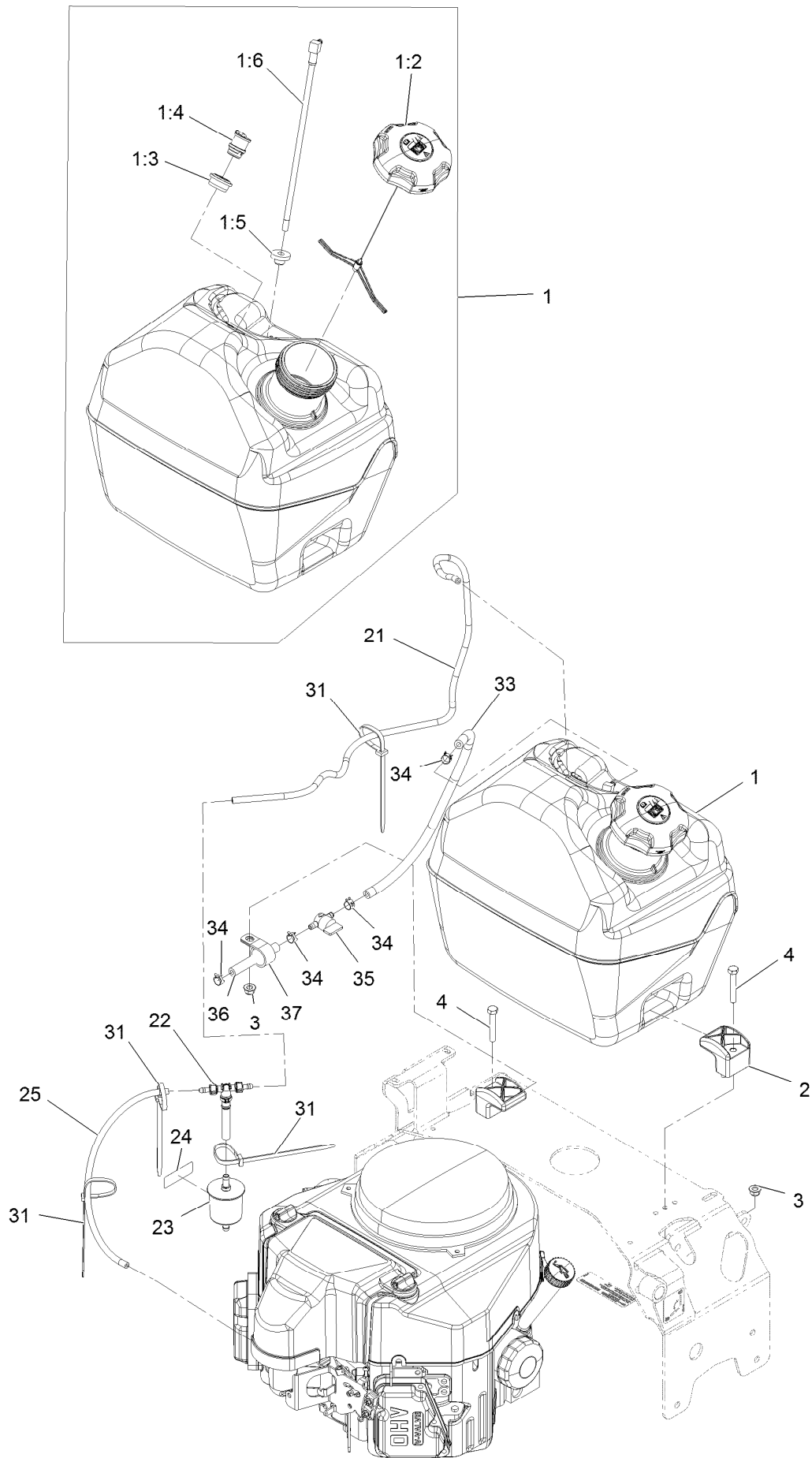

Fuel Assembly (continued)

<i>Ref.</i>	<i>Part Number</i>	<i>Qty.</i>	<i>Description</i>	<i>Ref.</i>	<i>Part Number</i>	<i>Qty.</i>	<i>Description</i>
1	126-9062	1	ASM, Fuel Tank 5 Gal	22	116-5464	1	Tee And Check
1:2	135-0330	1	Cap-Fuel, Ratcheting (3.5")	23	120-2235	1	Filter-Fuel
1:3	114-0284	1	Grommet	24	116-4769	1	Decal-Filter, Emissions
1:4	119-3547	1	Valve-Vent, Fuel	25	115-7872	1	Hose-Fuel
1:5	46-6560	1	Bushing	31	1-303335	4	Tie-Plastic
1:6	109-9364	1	Fitting-Fuel (W/Line And Screen)	33	114-4428	1	Hose-Fuel
2	107-4543	2	Clamp	34	2412-98	4	Clamp-Hose
3	104-8300	2	Nut-Flange, NI	35	1-603770	1	Valve-Fuel
4	322-10	2	Screw-HH	36	105-8342	1	Hose-Fuel
21	126-1679	1	Hose, Emissions	37	1-643312	1	Clip-Loom

Engine Assembly

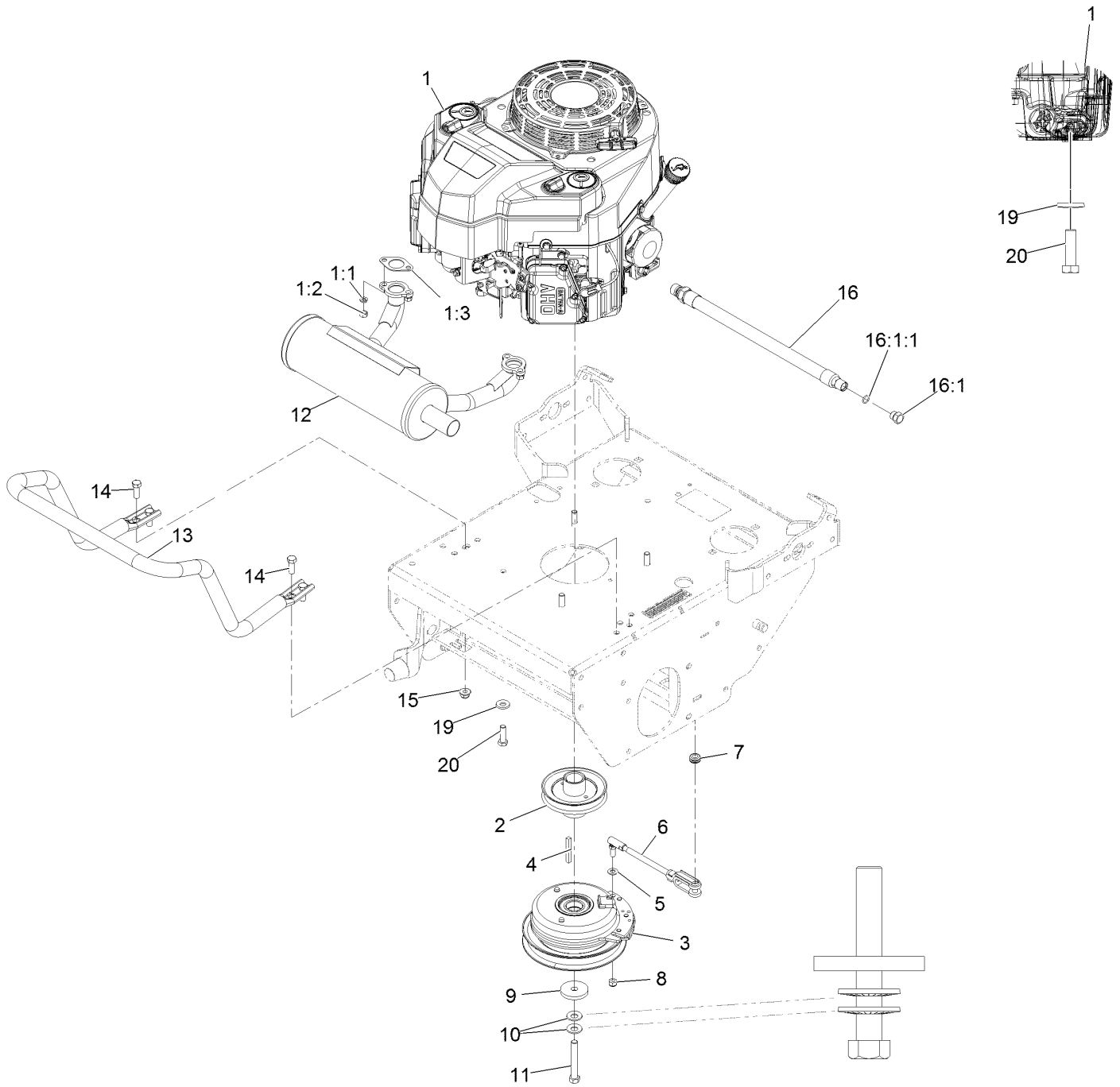

Engine Assembly (continued)

<i>Ref.</i>	<i>Part Number</i>	<i>Qty.</i>	<i>Description</i>	<i>Ref.</i>	<i>Part Number</i>	<i>Qty.</i>	<i>Description</i>
1		1	Engine, Kawasaki 481Cc●■	10	1-603610	2	Washer-Spring Disc 7/16
1:1	114-3550	4	Washer-Lock	11	3212-12	1	Screw-HH 7/16-20 X 3◆
1:2	114-3549	4	Nut	12	116-3735	1	Muffler-Horizontal
1:3	1-653313	2	Gasket-Exhaust	13	116-6278-03	1	Guard-Muffler
2	116-7328	1	Sheave, W/ Hub	14	323-6	4	Screw-HH 3/8-16 X 1
3	126-2615	1	Clutch, 105 Ft/Lbs, 1.13	15	104-8301	4	Nut-Nyloc 3/8-16 Flg
4	5-1336	1	Key-Machine 1/4 X 1/4 X 2□	16	116-5052	1	Asm-Oil Drain Hose W/Plug▲
5	3256-23	1	Washer-5/16 SAE	16:1	353-508	1	Plug-W/O-Ring
6	126-0620	1	ASM, Clutch Anchor	16:1:1	237-42	1	O-Ring
7	237-136	1	Grommet	19	98-5975	4	Washer-Spring Disc 3/8
8	3296-4	1	Nut-Lock 5/16-24	20	323-7	4	Screw-HH 3/8-16 X 1 1/4
9	109-6919	1	Washer-Clutch				

● Not serviced separately

■ Obtain parts from www.kawpowerepc.com

▲ Use a Teflon Pipe Sealant or equivalent on threads.

◆ Use Pro-Lock, Nut Type (P/N 1-840022, .5ml tube) on threads.

□ Apply anti-seize compound to engine crankshaft, pulley hub I.D., clutch bore I.D. and square key.

Ground Drive Assembly

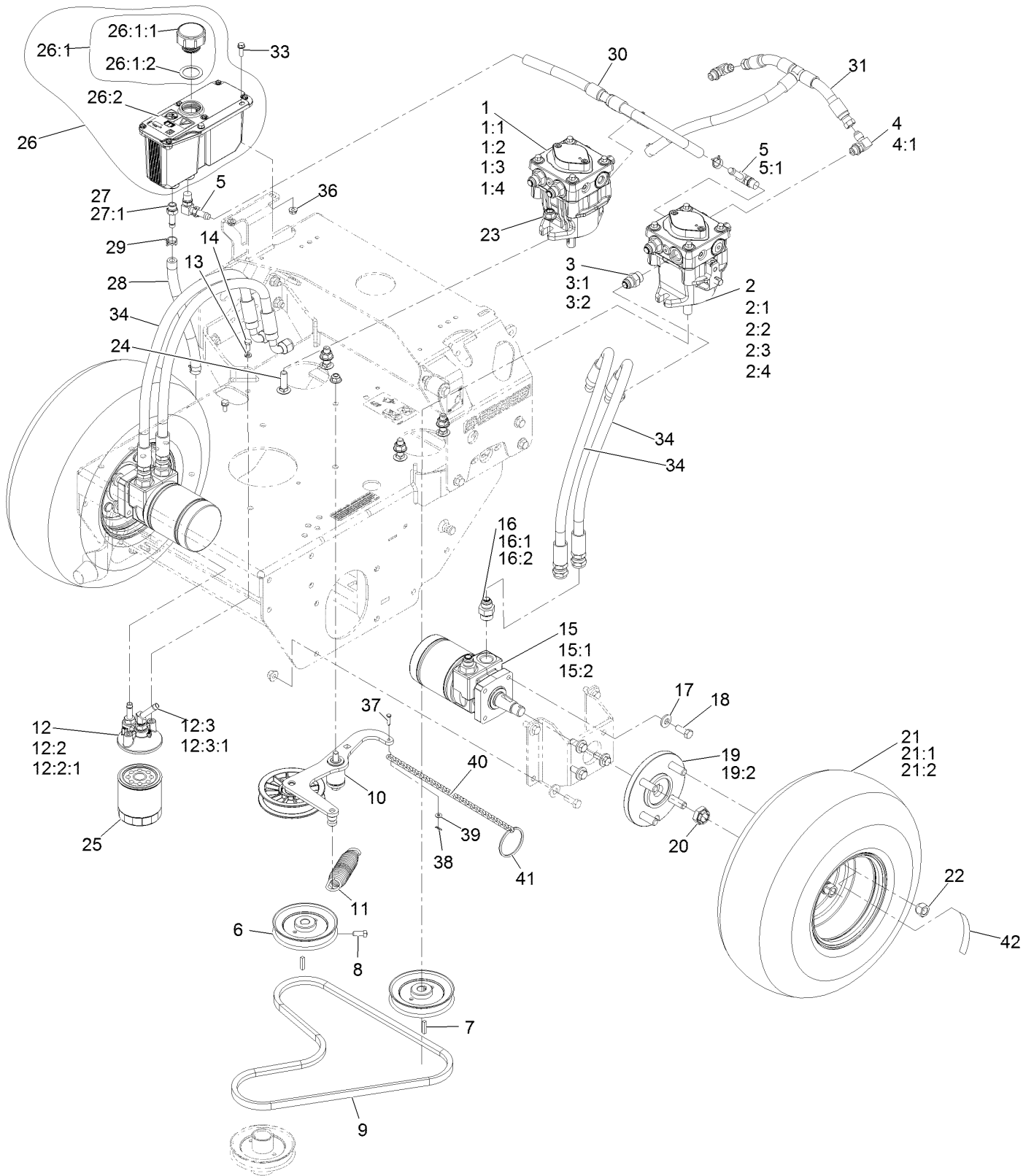

Ground Drive Assembly (continued)

<i>Ref.</i>	<i>Part Number</i>	<i>Qty.</i>	<i>Description</i>	<i>Ref.</i>	<i>Part Number</i>	<i>Qty.</i>	<i>Description</i>
1	116-0943	1	RH HYD Pump ASM	16:2	1-603992	1	O-Ring-37 Flare #8
1:1	103-2664	1	Input Shaft Kit	17	98-5975	8	Washer-Spring Disc 3/8
1:2	94-6922	1	Bearing-Thrust	18	323-6	8	Screw-HH 3/8-16 X 1
1:3	103-2666	1	Cylinder Block Kit	19	112-9049	2	Wheel Hub ASM
1:4	105-6184	1	Seal Overhaul Kit	19:2	1-633926	4	Stud-Wheel
2	116-0942	1	LH HYD Pump ASM	20	116-2839	2	Nut-Lock
2:1	103-2664	1	Input Shaft Kit	21	1-613263	2	Wheel And Tire ASM
2:2	94-6922	1	Bearing-Thrust	21:1	1-613264	1	Tire-Turfmaster
2:3	103-2666	1	Cylinder Block Kit	21:2	1-603715	1	Wheel-Rim
2:4	105-6184	1	Seal Overhaul Kit	22	242-50	8	Nut-Lug 1/2-20
3	1-603990	4	Adapter-Straight	23	114-8417	4	Nut-HF, NI
3:1	1-603920	1	O-Ring-SAE #8	24	3232-3	4	Bolt-Carriage 7/16-14 X 1 1/2
3:2	1-603992	1	O-Ring-37 Flare #8				
4	103-1802	2	Ftg-Elbow 90D	25	109-4180	1	Element, Oil Filter
4:1	237-42	1	O-Ring	26	126-1248	1	ASM, HYD Reservoir ■
5	100-4887	3	Fitting-Barbed, 90 DEG	26:1		1	Reservoir-HYD ●
5:1	237-42	1	O-Ring	26:1:1	103-1948	1	Cap-Reservoir, HYD
6	1-413010	2	Sheave ASM	26:1:2	103-1949	1	Gasket-Cap
7	1-807272	2	Key-5Mm X 5Mm X 25Mm	26:2	115-4212	1	Decal-Warning
8	120-6474	4	Screw-Set, SQH 5/16-18 X 3/4	27	103-1912	1	Adapter-Straight
9	103-4761	1	Belt	27:1	237-42	1	O-Ring
10	126-0615	1	ASM, Pump Idler	28	103-2959	1	Hose-Charge
11	116-6316	1	Spring-Extension	29	103-1988	6	Clamp-Hose 11/16
12	126-0621	1	ASM, Filter Head	30	126-0623	1	Hose-Case Drain
12:2	103-1912	1	Adapter-Straight	31	126-0622	1	Hose-Charge
12:2:1	237-42	1	O-Ring	33	32105-15	2	Screw-Machine 1/4-20 X 3/4
12:3	103-1807	1	Fitting-Barbed, 45 DEG	34	119-7827	4	HYD Hose ASM
12:3:1	237-42	1	O-Ring	36	32128-33	2	Nut-Whizlock 1/4-20
13	1-805004	2	Washer-Lock 1/4 Heavy	37	283-16	1	Pin-Clevis
14	321-3	2	Screw-HH 1/4-20 X 5/8	38	108-2992	1	Pin-Hair
15	1-603718	2	HYD Motor ASM	39	3269-26	1	Washer-Plain
15:1	1-000119	1	Seal Kit	40	1-323365	1	Chain-Link, Twist
15:2	1-000138	1	Bearing And Seal Kit	41	1-323366	1	Ring-Split
16	1-603991	4	Adapter-Straight	42	126-2056	2	Decal-Torque Wheel Lug-Hub
16:1	237-80	1	O-Ring				

● Not serviced separately

■ Use Exmark Premium Hydro Oil P/N 109-9828 (32oz)

Pump Idler Assembly No. 126-0615

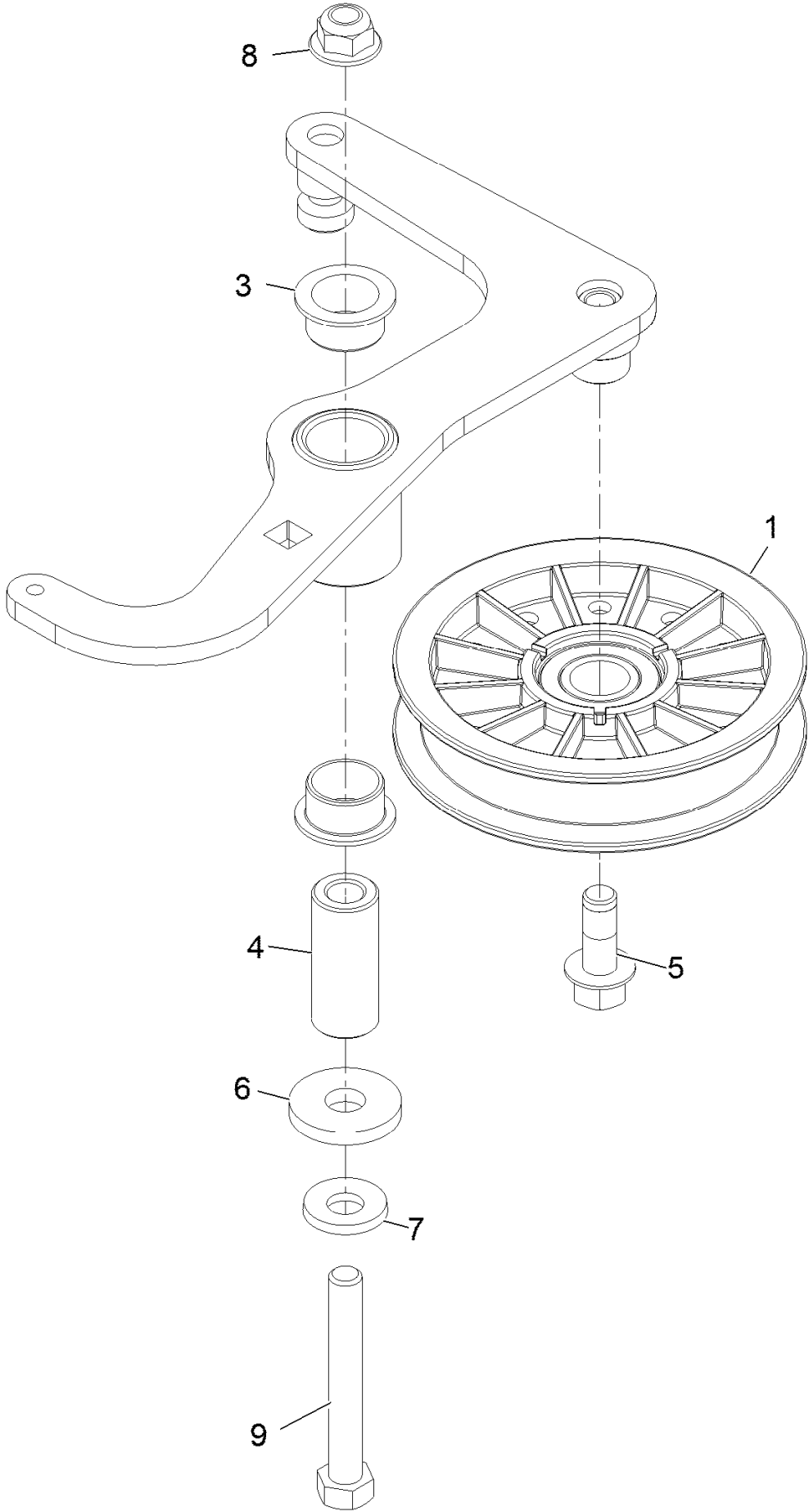

Pump Idler Assembly No. 126-0615 (continued)

<i>Ref.</i>	<i>Part Number</i>	<i>Qty.</i>	<i>Description</i>	<i>Ref.</i>	<i>Part Number</i>	<i>Qty.</i>	<i>Description</i>
1	109-4077	1	Pulley-Idler, Flat	6	1-373034	1	Washer
3	109-8054	2	Bushing-Flanged	7	98-5975	1	Washer-Spring Disc 3/8
4	116-8718	1	Spacer, Pivot	8	104-8301	1	Nut-Nyloc 3/8-16 Flg
5	126-1680	1	Screw-Hfh	9	112-7451	1	Screw-TAP

Electrical Assembly

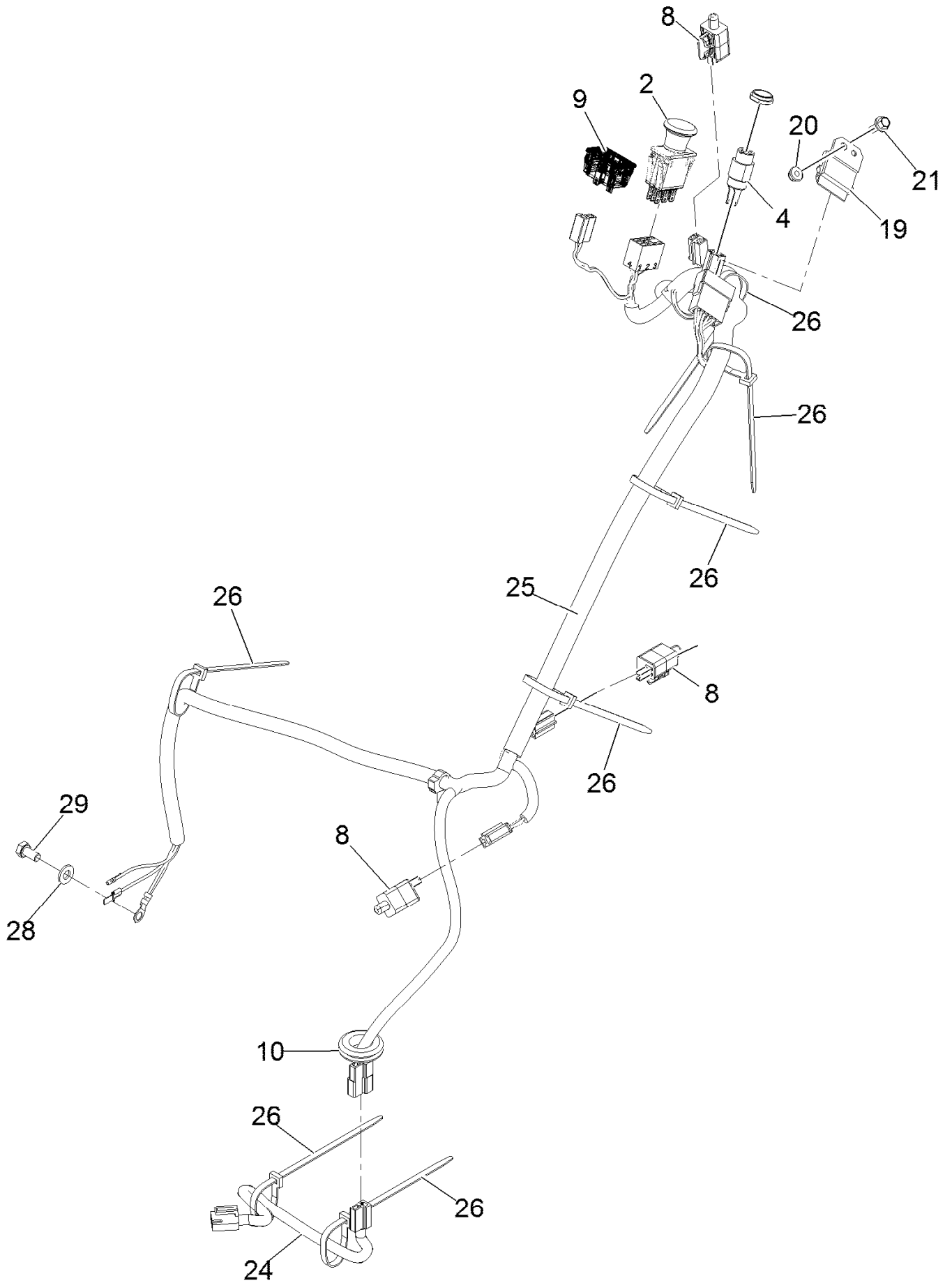

Electrical Assembly (continued)

<i>Ref.</i>	<i>Part Number</i>	<i>Qty.</i>	<i>Description</i>	<i>Ref.</i>	<i>Part Number</i>	<i>Qty.</i>	<i>Description</i>
2	103-5221	1	Switch-PTO	20	104-7201	1	Nut-Nyloc 1/4-20 Flg
4	1-403121	1	Switch & Key (Includes Nut & Washer)	21	126-1592	1	Screw-Flange Head, 1/4-20 X .625
4	103-0498	1	Nut-Ignition	24	126-0624	1	Harness-Clutch Pigtail
8	110-6765	3	Switch	25	126-0625	1	Harness-Main ●
9	126-3931	1	Hour Meter	26	1-303335	7	Tie-Cable 7 15/16 (Large)
10	1-543286	1	Grommet	28	33094-00	1	Washer
19	1-323430	1	Module-Interlock	29	33114-016	1	Screw-HH M8-1.25 X 16Mm

● Use dielectric grease on all unsealed connectors and terminals only. Do not apply in sealed connectors.

Notes:



MAXIMIZE THE PERFORMANCE OF YOUR EXMARK MACHINE.



EXMARK® PREMIUM ENGINE OIL

Exmark now offers a family of engine oil viscosities to perform well in any environment. Each viscosity has the same synthetic formulation to give you what you need in punishing conditions. We designed each grade to the highest quality, making it ideal even for diesel applications. Coupled with Exmark Premium Fuel Treatment, we have the performance products to make your machine hum.

EXMARK PREMIUM ENGINE OIL SAE 30/10W-30

- Meets zero shear requirements of a straight grade SAE 30 as well as the cold temp properties of a 10W-30.
- Most versatile oil in the industry.
- Superior corrosion protection over conventional oil - even in corrosive, humid environments.

EXMARK PREMIUM ENGINE OIL SAE 20W-50

- Perfect for your big block engine, or any application in severe service.
- Same full synthetic formulation as all other Exmark Premium viscosities.
- Also effective for use in severe service small block engines.

EXMARK PREMIUM ENGINE OIL SAE 10W-50

- Full synthetic formulation gives you peak performance. Don't settle for less.
- Wide span multi-grade combines easy starting in cold weather with maximum protection in high temperature operation.
- Reduce friction & wear over standard mineral formulations.

EXMARK PREMIUM ENGINE OIL SAE 0W-40

- The perfect choice for when the weather turns cold or unpredictable, and your Exmark UTV has to perform.
- Commercial quality for severe service.
- Advanced additive package helps prevent corrosion from long-term storage.

EXMARK PREMIUM ENGINE OIL UTV FORMULATION

- 4-cycle high-temp formulation.
- Heavier viscosity, full synthetic, perfect for your UTV.

EXMARK PREMIUM UTV EXTREME CONDITIONS GEAR OIL

- SAE 80W-90, designed to keep your UTV performing at its peak.
- Shear stable, hypoid gear lube.
- Includes a premium additive system to combat wear, oxidation, rust & corrosion.

Available from your local Exmark dealer. Find your closest dealer at exmark.com

EXMARK ACCESSORIES AND OPTIONS*

MID-MOUNT RIDING ACCESSORIES AND OPTIONS

CUSTOM RIDE SEAT SUSPENSION SYSTEM	OPERATOR CONTROLLED DISCHARGE
FULL SUSPENSION SEAT	SUN SHADE
DECK LIFT ASSIST KIT	TRASH CONTAINER
HITCH KIT	TURF STRIPER
LIGHT KIT	ULTRA VAC COLLECTION SYSTEM
12V POWER PORT	ULTRA VAC QUICK DISPOSAL SYSTEM
MICRO-MULCH SYSTEM	

OUT-FRONT RIDING ACCESSORIES AND OPTIONS

CUSTOM RIDE SEAT SUSPENSION SYSTEM	SNOW BLADE
DUAL-TAIL WHEEL	SNOWBLOWER
FLOOR PAN EXTENDER	SUN SHADE
HITCH KIT	TRASH CONTAINER
LIGHT KIT	ULTRA VAC COLLECTION SYSTEM
MICRO-MULCH SYSTEM	ULTRA VAC QUICK DISPOSAL SYSTEM
ROLL OVER PROTECTION SYSTEM (ROPS)	WEATHER CAB

WALK-BEHIND ACCESSORIES AND OPTIONS

GRASS CATCHER	TURF STRIPER
MICRO-MULCH SYSTEM	STANDON

*Some accessories and options not available for some models.

Place Model No. and Serial No.
Label Here (Included in the Literature
Pack) or Fill in Below

Model No. _____

Serial No. _____

Date Purchased _____

Engine Model No. and Spec. No. _____

Engine Serial No. (E/No) _____

© 2016 Exmark Mfg. Co., Inc.
Industrial Park Box 808
Beatrice, NE 68310
All Rights Reserved

Part No. 4502-979 Rev. A
(402) 223-6375
Fax (402) 223-5489
Printed in the USA.

