



RADIUS® X-SERIES

Model No. RAX691GKA524A3—Serial No. 40000000 and Up

Picture below may not reflect actual product.



Parts Manual

Part No. 4502-919 Rev. A

Ordering Replacement Parts

To order replacement parts, please supply the part number, the quantity, and the description of each part desired.

Understanding Reference Numbers

Each identified part in an illustration has a reference number. The reference number for a part also appears in the parts list, along with other information about the part.

This catalog uses two special reference number formats, one to indicate parts in a service assembly and another to indicate the quantity of a given part in an illustration.

Service Assembly Reference Numbers

Parts in service assemblies have reference numbers in the form a:b. The a represents the reference number of the entire service assembly and the b represents a sequential number unique to each part within the service assembly.

For example, a wheel assembly might be identified by reference number 6, the tire by 6:1, the valve by 6:2, and the wheel by 6:3. When you order the assembly identified by reference number 6, you receive all parts identified by reference numbers 6:1, 6:2, and 6:3. However, you may also order any part individually. Reference numbers of this type appear in illustration and in parts lists.

Reference Numbers Indicating Quantity

In an illustration, if a reference number indicates more than one part, the reference number has the form nX y. The n represents the quantity of the part, the X is the multiplication symbol, and the y represents the reference number.

For example, in an illustration, the reference number 2X 37 means that two of the parts identified by reference number 37 are indicated.

List of Abbreviations

AR: as required	HLH: hex lag head	PTH: phillips truss head
ASM: assembly	HOC: height-of-cut	PTO: power-take-off
BBC: blade brake control	HP: high pressure	RH: right hand
BHTF: button head thread forming	HSBH: hex socket button head	ROPS: roll-over protection system
CARR: carriage	HSFH: hex socket flat head	RRB: rear roller brush
CCW: counter clockwise	HSH: hex socket head	SFH: slotted fillister head
CW: clockwise	HWH: hex washer head	SHH: slotted hex head
DEG: degrees	HWHTF: hex washer head thread forming	SHWH: slotted hex washer head
DPA: Dual Point Adjustment	HYD: hydraulic	SPH: slotted pan head
ECM: electronic control module	LH: left hand	SQH: square head
EXT: external	LP: low pressure	SRH: slotted round head
FH: flat head	LPG: Liquefied Petroleum Gas	STD: standard
GA: gauge	NI: nylon insert	TAP: self tapping
HD: heavy-duty	NPTF: national pipe thread fine	TTH: torx truss head
HF: hex flange	PFH: phillips flat head	
HH: hex head	PPH: phillips pan head	
HHF: hex head flange	PPHTF: phillips pan head thread forming	
HHFTF: hex head flange thread forming	PRH: phillips round head	
HJ: hex jam		

Touch Up Paint

Exmark black touch up spray paint – gloss black.

Exmark red touch up paint (spray paint – P/N 1-850337 - .6 oz liquid bottle – P/N 103-9140).



If your Exmark dealer does not have the Exmark part in stock, Exmark will get the parts to the dealer the next business day or the part will be FREE Guaranteed!! (Some restrictions apply. See your participating Exmark Dealer for details.)

Contents

Complete Deck Assembly.....	4
Deck Assembly.....	6
Deck W/Decals Assembly.....	8
Idler Arm W/Bearings Assembly.....	10
Frame Assembly.....	12
Caster Wheel and Fork Assembly.....	14
Roll-Over Protection System Assembly.....	16
Deck Lift Assembly.....	18
Deck Strut Assembly.....	20
Control Assembly.....	22
Motion Control Assembly.....	24
LH Motion Control Assembly.....	26
RH Motion Control Assembly.....	28
Fuel Assembly.....	30
Fuel Tank Assembly (cont.).....	32
Seat Assembly.....	34
Seat Latch Assembly.....	36
Seat Assembly (cont.).....	38
Engine Assembly.....	40
Hydraulic Assembly.....	42
LH Transaxle Assembly.....	44
RH Transaxle Assembly.....	46
Electrical Assembly.....	48
Harness Assembly.....	50

Complete Deck Assembly

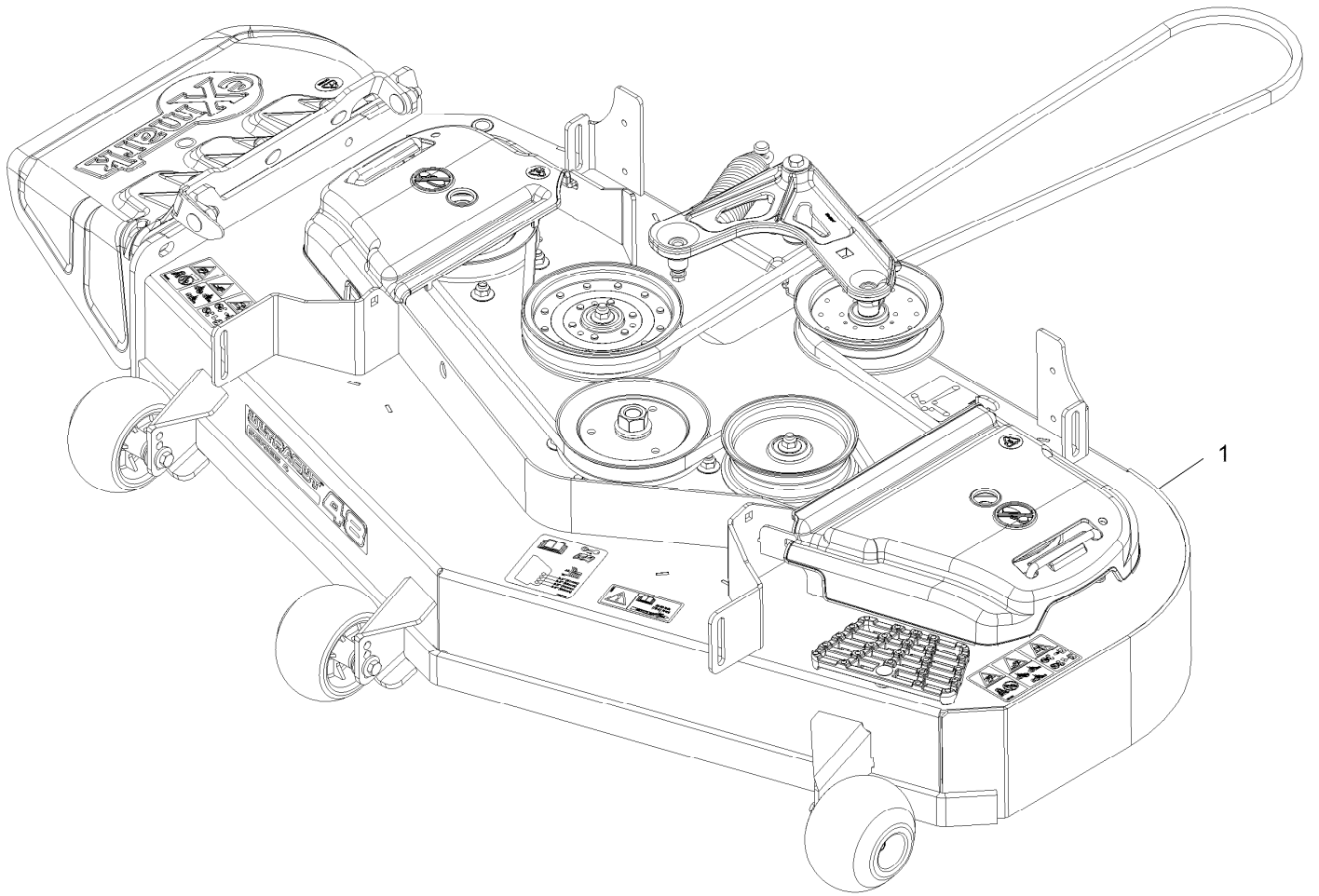

Complete Deck Assembly (continued)

<i>Ref.</i>	<i>Part Number</i>	<i>Qty.</i>	<i>Description</i>
1	126-8039	1	ASM-Deck Complete 524

Deck Assembly

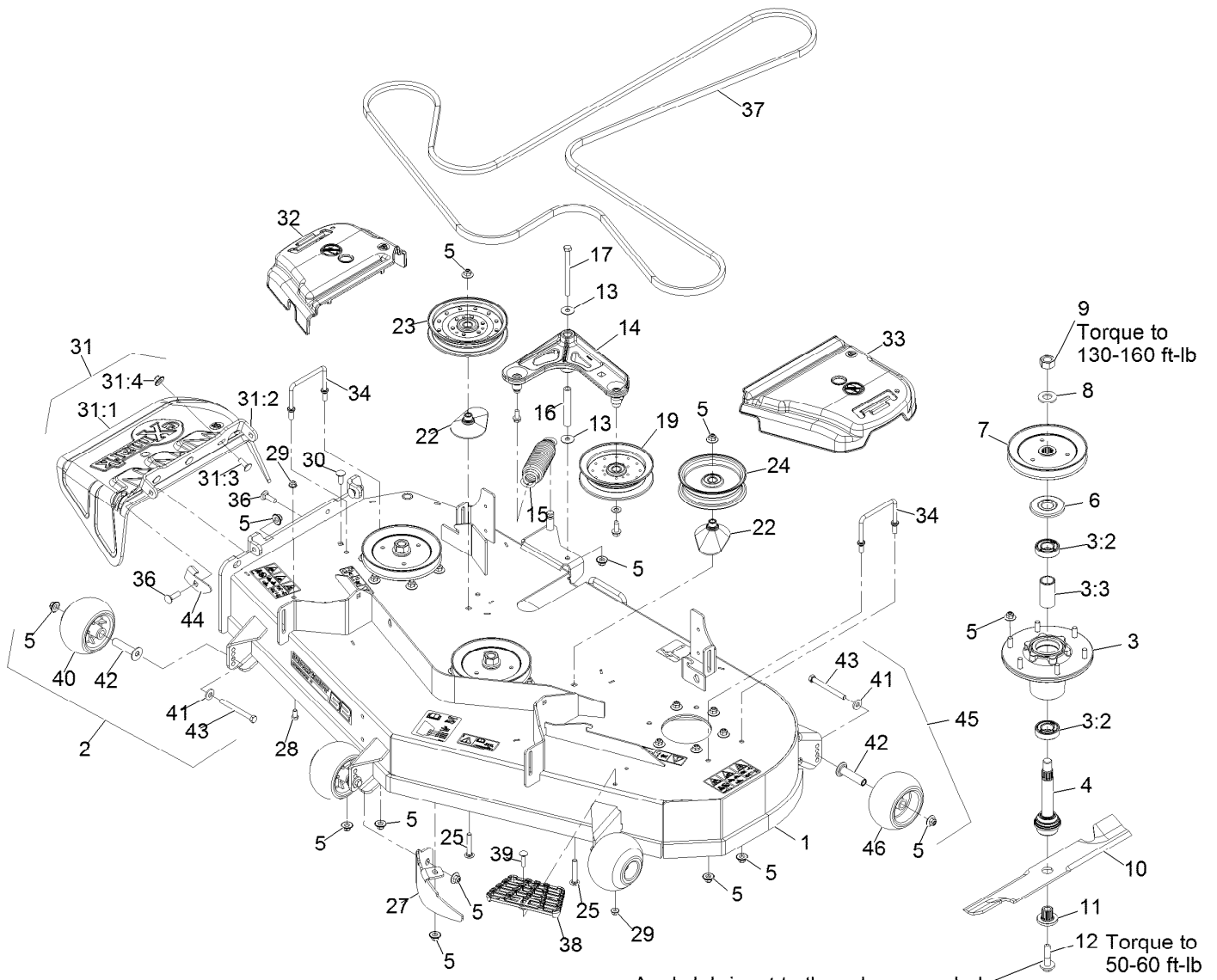

Apply lubricant to threads as needed to prevent seizing. Copper based anti-seize preferable. Grease is an acceptable substitute.

Deck Assembly (continued)

<i>Ref.</i>	<i>Part Number</i>	<i>Qty.</i>	<i>Description</i>	<i>Ref.</i>	<i>Part Number</i>	<i>Qty.</i>	<i>Description</i>
1	126-3587	1	ASM-Deck W/Decals 524	24	116-4669	1	Pulley-Idler Flat
2	116-9981	3	Kit, Anti-Scalp Roller	25	3231-40	2	Bolt-Carriage 3/8-16 X 2 1/4
3	116-3344	3	ASM-Cutter Hsg With Bearings	27	116-5814-01	1	Baffle-Dogleg, Lz-Vt52
3:2	116-0720	2	Bearing-Ball	28	322-2	1	Screw-HH 5/16-18 X 5/8
3:3	116-3312	1	Spacer-Bearing	29	104-8300	2	Nut-Nyloc 5/16-18 Flg
4	116-3341	3	ASM-Spindle And Seal	30	3231-22	1	Bolt-Carriage 3/8-16 X 1
5	109-6658	34	Nut-Nyloc 3/8-16 Flg	31	109-7188	1	ASM,Discharge Chute
6	116-1286	3	Guard,Bearing Top .989	31:1	109-2738	1	Chute, Discharge
7	116-0675	3	Sheave,Blade Drive 6.50	31:2	109-8675-01	1	Bracket,Discharge Chute
8	103-2802	3	Washer-Spring Disc 3/4	31:3	3231-22	3	Bolt-Carriage 3/8-16 X 1
9	116-7306	3	Nut-Hex	31:4	109-6658	3	Nut-Nyloc 3/8-16 Flg
10	116-5175	3	Blade-Extreme 2, 18.00"	32	109-6935	1	Cover-Belt, RH
10	103-6402	3	Blade-Notched	33	109-6936	1	Cover-Belt, LH
10	103-6392	3	Blade, Mulching ●	34	109-6982	2	Wireform-Cover
10	103-6382	3	Blade, Solid	36	3231-25	3	Bolt-Carriage 3/8-16 X 1 1/4
10	103-6387	3	Blade, Low Lift	37	126-7443	1	Belt-V
11	103-3037	3	Bushing, Splined	38	126-4781-03	1	Step-Deck
12	109-9220	3	Screw-Sems 1/2-20 X 2.19	39	3230-3	1	Bolt-Carriage 5/16-18 X 1 1/4
13	52-2860	2	Washer	40	103-8415	3	Roller-Anti-Scalp
14	126-0976	1	ASM-Idler Arm W/Bearings	41	98-5975	5	Washer-Spring Disc 3/8
15	116-6317	1	Spring-Extension	42	116-8131	5	Axle, Roller
16	116-5111	1	Bushing	43	116-9362	5	Screw-HH 3/8-16 X 3 3/4 Gr 8
17	323-38	1	Screw-HH 3/8-16 X 4 3/4	44	135-0064	1	Stop-Discharge Chute
19	116-4668	1	Idler-Pulley, Flanged	45	126-7840	2	Kit-Antiscalp Roller
22	109-2872	2	Spacer-Pulley	46	1-603299	2	Roller-Scalp, Anti
23	116-4670	1	Pulley-Idler, Flat				

● Requires installation of mulch kit for proper mulching. See your Exmark dealer for details.

Deck W/Decals Assembly

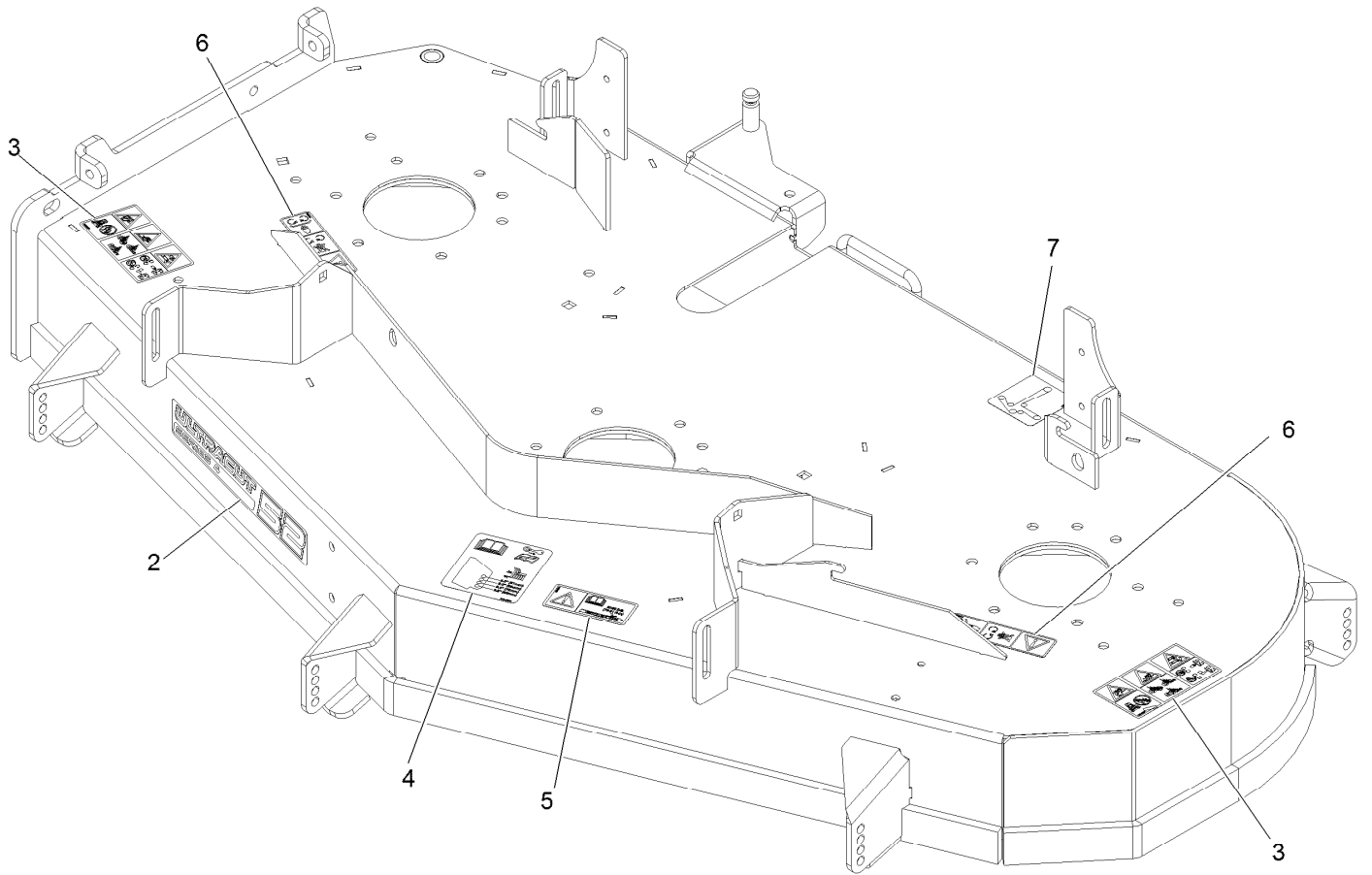

Deck W/Decals Assembly (continued)

<i>Ref.</i>	<i>Part Number</i>	<i>Qty.</i>	<i>Description</i>	<i>Ref.</i>	<i>Part Number</i>	<i>Qty.</i>	<i>Description</i>
2	126-6588	1	Decal, 524	5	116-8283	1	Decal-Bolt Torque
3	126-6464	2	Decal-Danger Thrown Objects	6	112-9028	2	Decal-Missing, Cover
4	109-6036	1	Decal-Roller, Anti-Scalp	7	109-6035	1	Decal-Belt Routing

Idler Arm W/Bearings Assembly

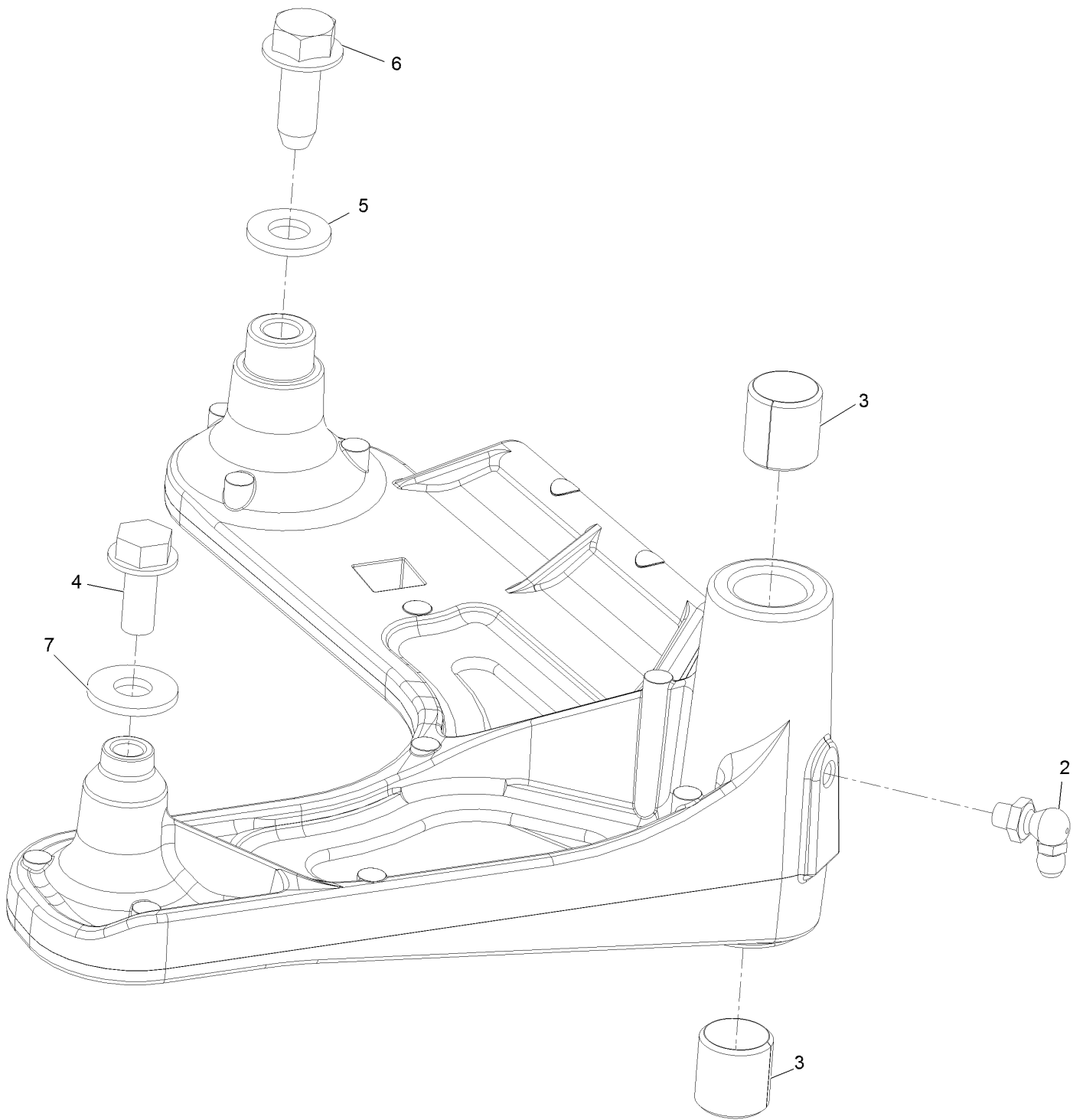

Idler Arm W/Bearings Assembly (continued)

<i>Ref.</i>	<i>Part Number</i>	<i>Qty.</i>	<i>Description</i>	<i>Ref.</i>	<i>Part Number</i>	<i>Qty.</i>	<i>Description</i>
2	302-40	1	Zerk-90° 1/4-28	5	3256-24	1	Washer-3/8 Sae
3	1-513034	2	Sleeve-Bearing	6	126-1696	1	Screw-Thread Forming
4	32144-11	1	Screw-HWH 5/16-18 X 3/4 Tf	7	3256-3	1	Washer-5/16 Std

Frame Assembly

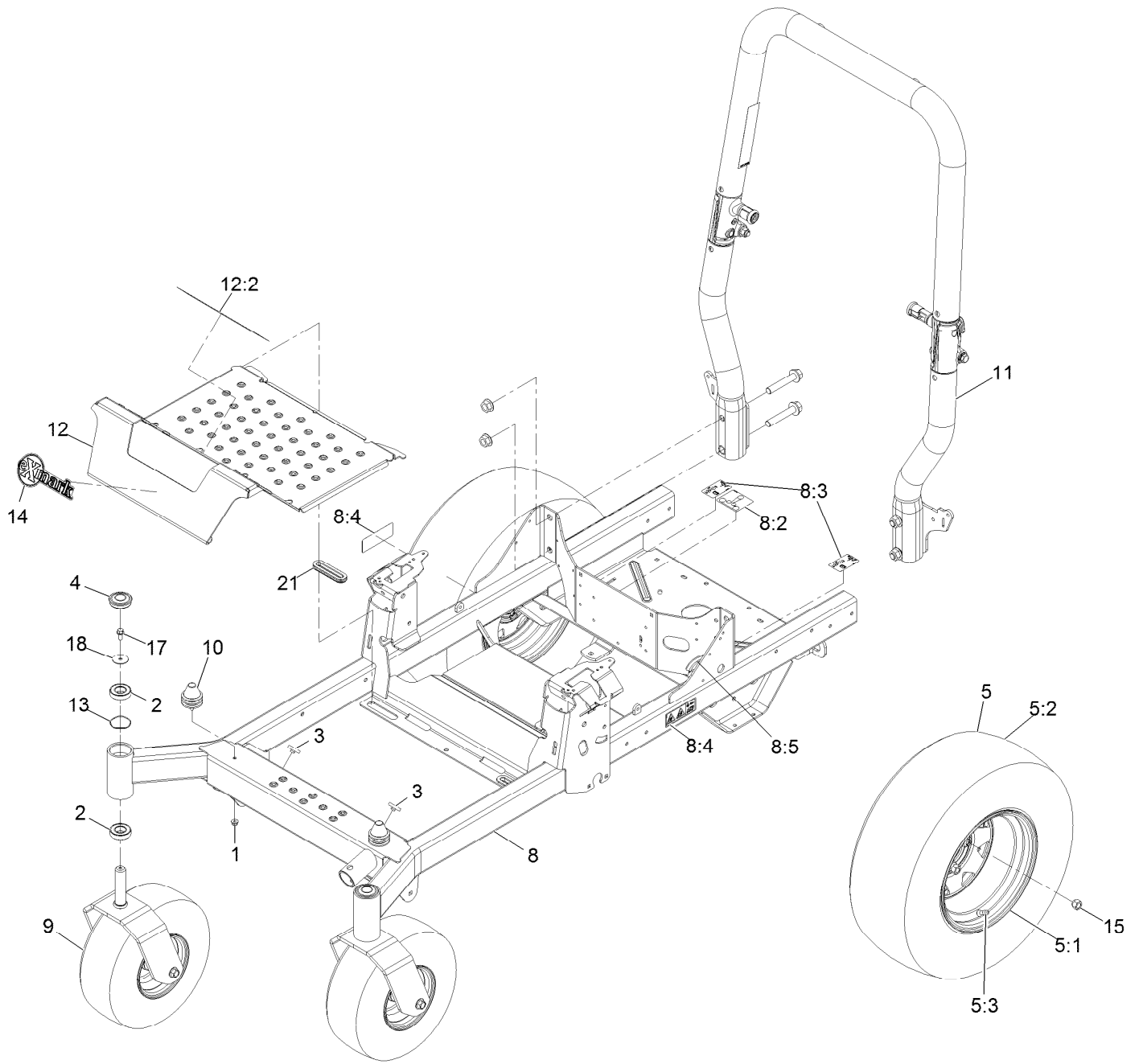

Frame Assembly (continued)

<i>Ref.</i>	<i>Part Number</i>	<i>Qty.</i>	<i>Description</i>	<i>Ref.</i>	<i>Part Number</i>	<i>Qty.</i>	<i>Description</i>
1	104-8300	2	Nut-Nyloc 5/16-18 Flg	8:5	127-6618	1	Strip-Seal
2	109-3678	4	Bearing-Ball	9		2	ASM-Front Caster W/Fork ●
3	109-9233	2	Bumper-Push-In, Rubber	10	126-5491	2	Isolator
4	116-4348	2	Cap-Grease	11	126-9525	1	ASM-ROPS Tapered
5	126-7824	2	Wheel And Tire ASM	12	126-5872	1	Pan Floor
5:1	116-6320	1	Wheel	12:2	126-8383	1	Decal-Danger
5:2	126-4875	1	Tire-K500 24X9.5-12	13	126-5897	2	Spring
5:3	232-27	1	Stem-Valve	14	126-8819	1	Decal-Exmark Logo
8	126-4699	1	Frame ASM	15	242-50	8	Nut-Lug 1/2-20
8:2	109-6014	1	Decal-Belt Routing	17	3234-5	2	Screw-HH Flg 5/16-18 X 3/4
8:3	116-8588	2	Decal-Drive Release	18	3256-68	2	Washer-Flat
8:4	126-4363	2	Decal-Warning Rotating Devices	21	126-7065	2	Grommet-Rubber

● Not serviced separately

Caster Wheel and Fork Assembly

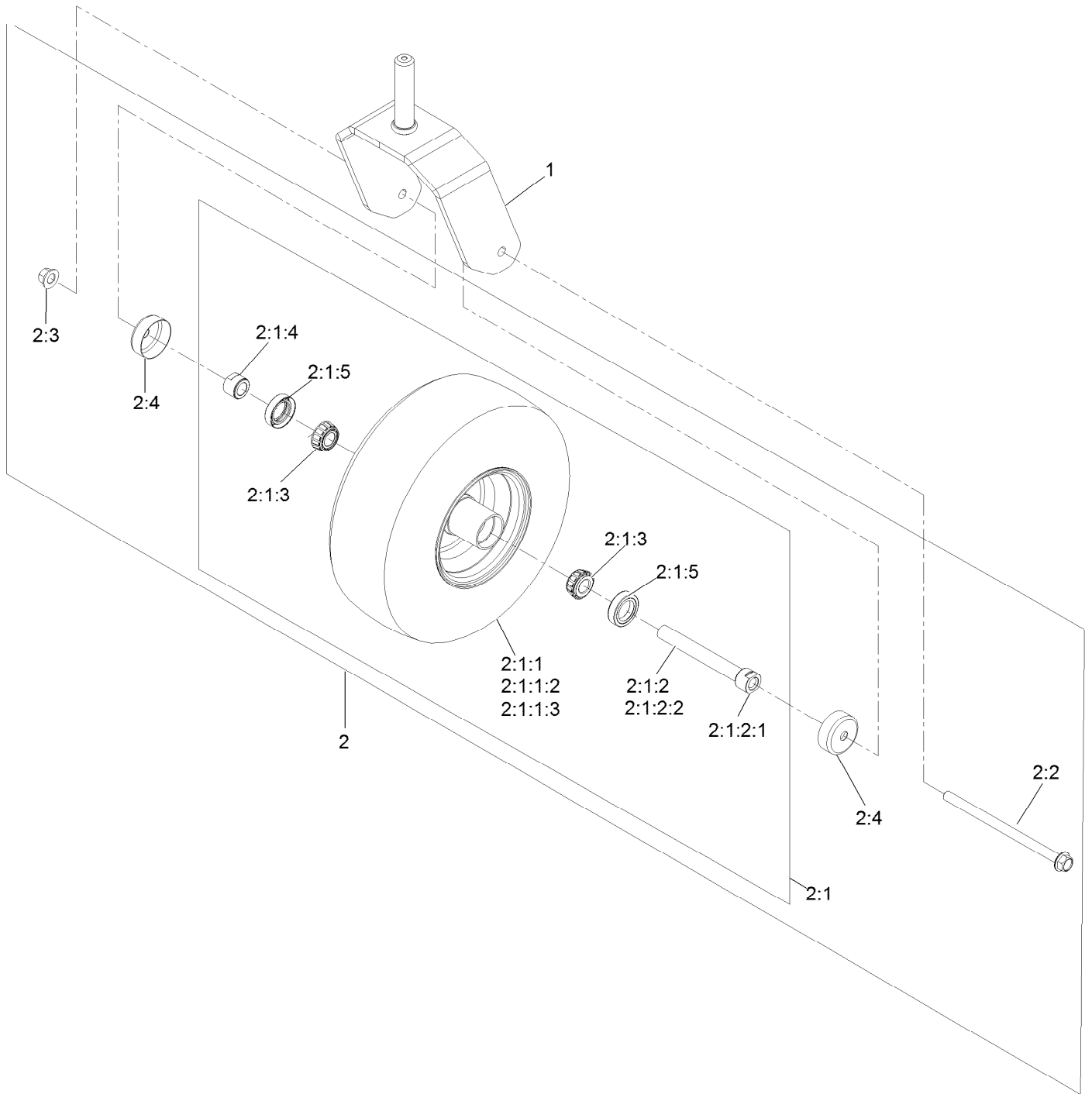

Caster Wheel and Fork Assembly (continued)

<i>Ref.</i>	<i>Part Number</i>	<i>Qty.</i>	<i>Description</i>	<i>Ref.</i>	<i>Part Number</i>	<i>Qty.</i>	<i>Description</i>
1	126-4312-01	1	Fork-Caster	2:1:2:1	126-5220	1	Axle, Caster
2	126-7752	1	ASM-Wheel Brgs Axle 13X6.50-6	2:1:2:2	103-3051	1	Spacer-Nut
2:1		1	ASM-Wheel And Brgs, 13X6.50-6 ●	2:1:3	1-633585	2	Bearing-Cone Tapered Roller
2:1:1		1	ASM-Wheel And Tire 13X6.50-6 ●	2:1:4	103-3051	1	Spacer-Nut
2:1:1:2	5108	1	Valve	2:1:5	103-0063	2	Seal-Double Lip
2:1:1:3	126-5959	1	Tire	2:2	126-5389	1	Screw-HHF
2:1:2	126-7796	1	Axle ASM-Caster	2:3	99-5107	1	Nut-Lock 1/2-13
				2:4	103-2768	2	Guard-Seal

● Not serviced separately

Roll-Over Protection System Assembly

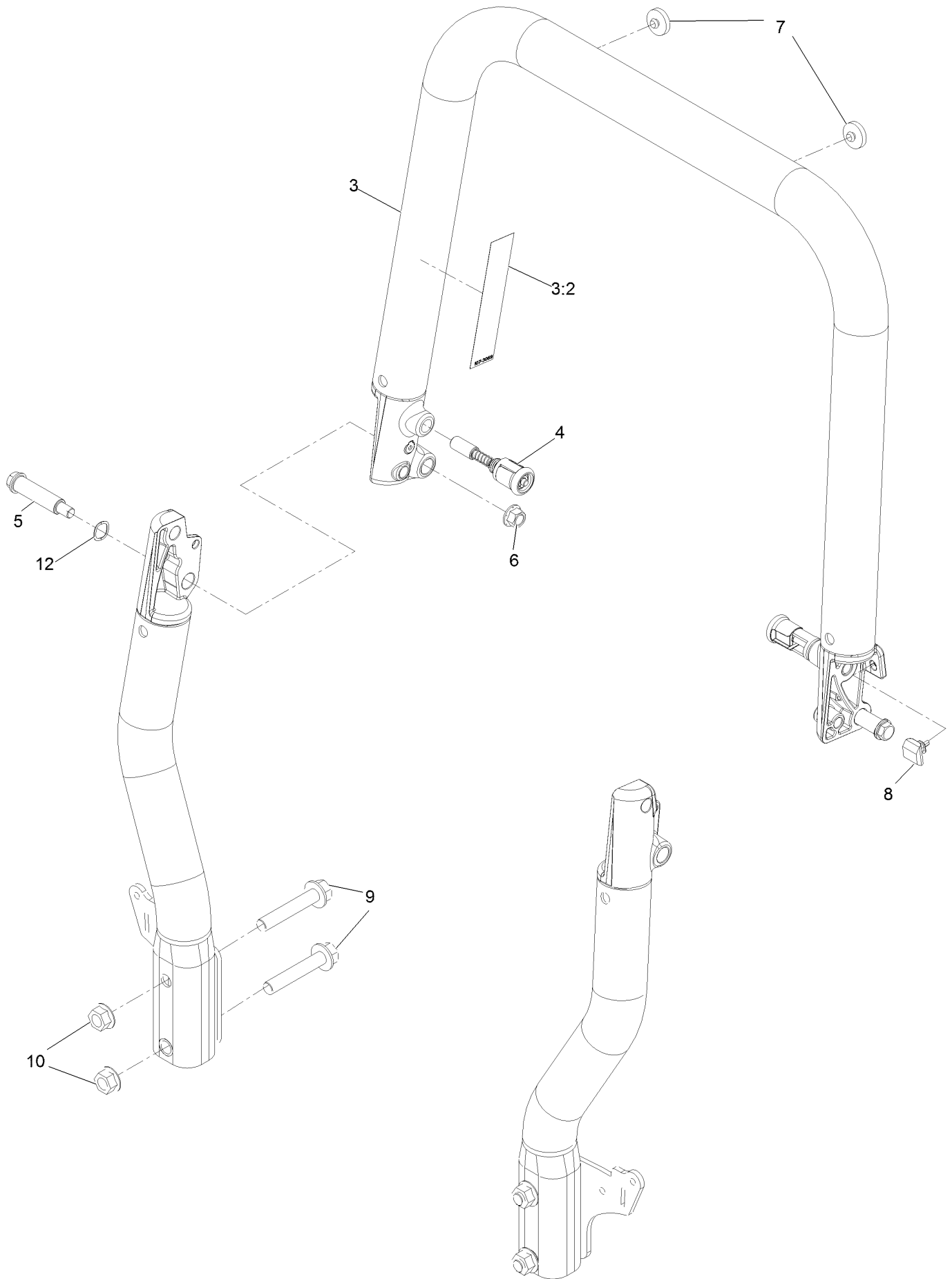

Roll-Over Protection System Assembly (continued)

<i>Ref.</i>	<i>Part Number</i>	<i>Qty.</i>	<i>Description</i>	<i>Ref.</i>	<i>Part Number</i>	<i>Qty.</i>	<i>Description</i>
3	126-7838	1	Tube Top ASM	7	109-9233	2	Bumper-Push-In, Rubber
3:2	107-3069	1	Decal-Warning, Folding ROPS	8	126-9966	2	Bumper,ROPS
4	116-0104	2	Pin-Spring	9	126-9488	4	Screw-HHF 5/8-18 X 3 1/2 Gr 8
5	126-9209	2	Bolt-Shoulder	10	32128-50	4	Nut-Whizlock 5/8-11
6	99-5107	2	Nut-Lock 1/2-13	12	119-4164	2	Washer-Wave

Deck Lift Assembly

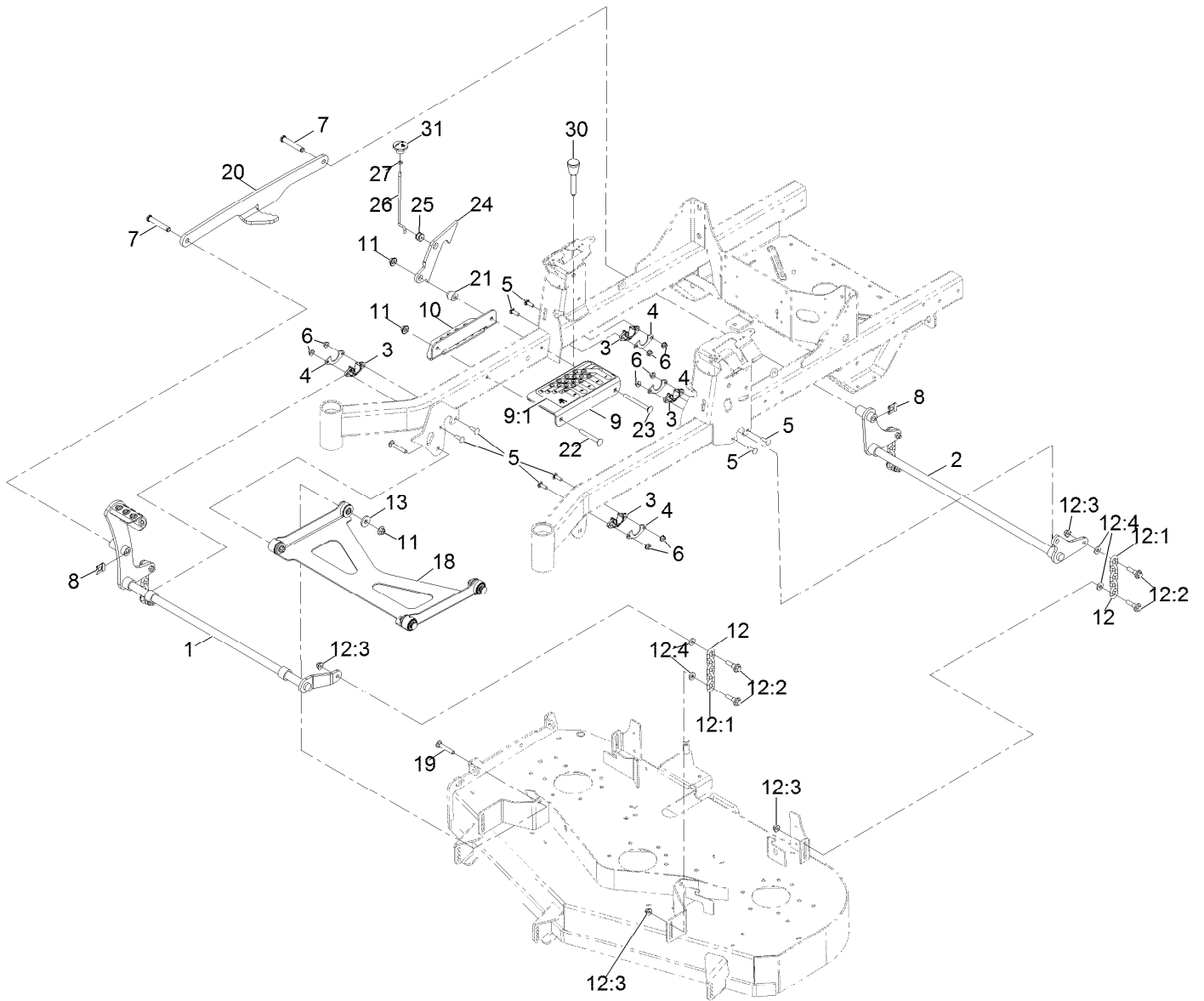

Deck Lift Assembly (continued)

<i>Ref.</i>	<i>Part Number</i>	<i>Qty.</i>	<i>Description</i>	<i>Ref.</i>	<i>Part Number</i>	<i>Qty.</i>	<i>Description</i>
1	126-3342-03	1	Shaft-Lift, Deck	12:3	104-8301	2	Nut-Flange, NI
2	126-3343-03	1	Shaft-Lift, Rear Deck	12:4	43-0940	2	Spacer
3	115-5065	4	Bushing-Flange	13	1-373034	2	Washer
4	116-2887	4	Gusset-Lift, Deck	18	126-8365	1	Deck Strut ASM
5	3230-22	8	Screw-CARR	19	3231-7	2	Screw-CARR
6	104-8300	8	Nut-Flange, NI	20	126-4639-03	1	Link-Lift
7	126-9181	2	Pin-Clevis	21	126-5221	1	Spacer-Stepped
8	95-4064	2	Clip-Pin	22	3231-42	1	Screw-CARR
9	126-4535	1	Bracket ASM	23	3231-37	1	Screw-CARR
9:1	126-4784	1	Decal-Height Of Cut	24	126-5222	1	Plate-Lock, Transport
10	126-4640-03	1	Angle-HOC, Lower	25	126-5593	1	Grommet
11	109-6658	4	Nut-Flange, NI	26	126-5223	1	Rod-Lock, Transport
12	126-8877	4	Deck Chain ASM	27	3218-1	1	Nut-Jam
12:1	1-633447	1	Chain-Lift, Deck	30	126-5401	1	Pin-HOC
12:2	130-0742	2	Bolt-Shoulder	31	126-7019	1	Knob

Deck Strut Assembly

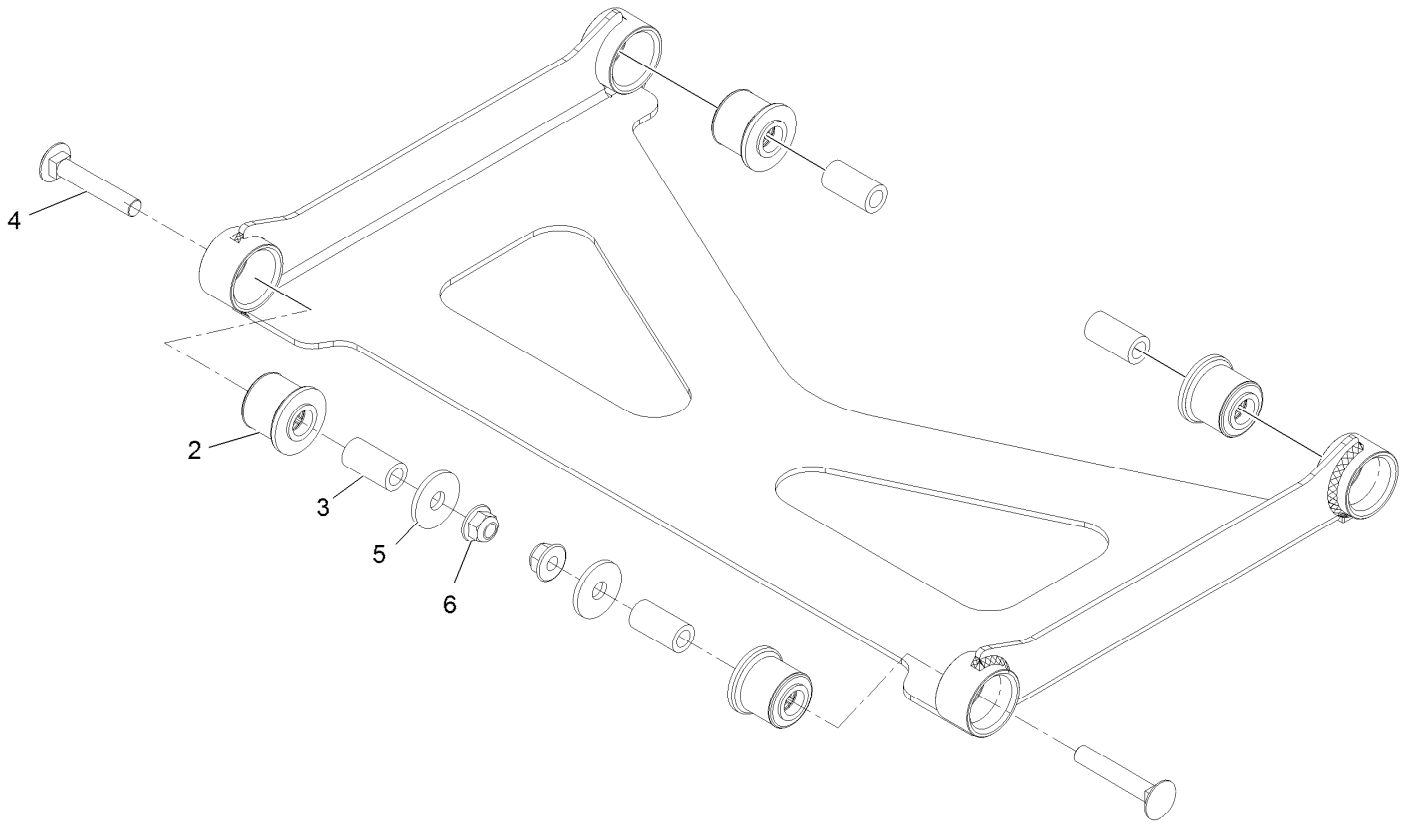

Deck Strut Assembly (continued)

<i>Ref.</i>	<i>Part Number</i>	<i>Qty.</i>	<i>Description</i>	<i>Ref.</i>	<i>Part Number</i>	<i>Qty.</i>	<i>Description</i>
2	126-8360	4	Bushing-Rubber, Suspension	4	3231-7	2	Bolt-Carriage 3/8-16 X 2 1/4
3	108-6544	4	Spacer	5	2844	2	Washer
				6	104-8301	2	Nut-Nyloc 3/8-16 Flg

Control Assembly

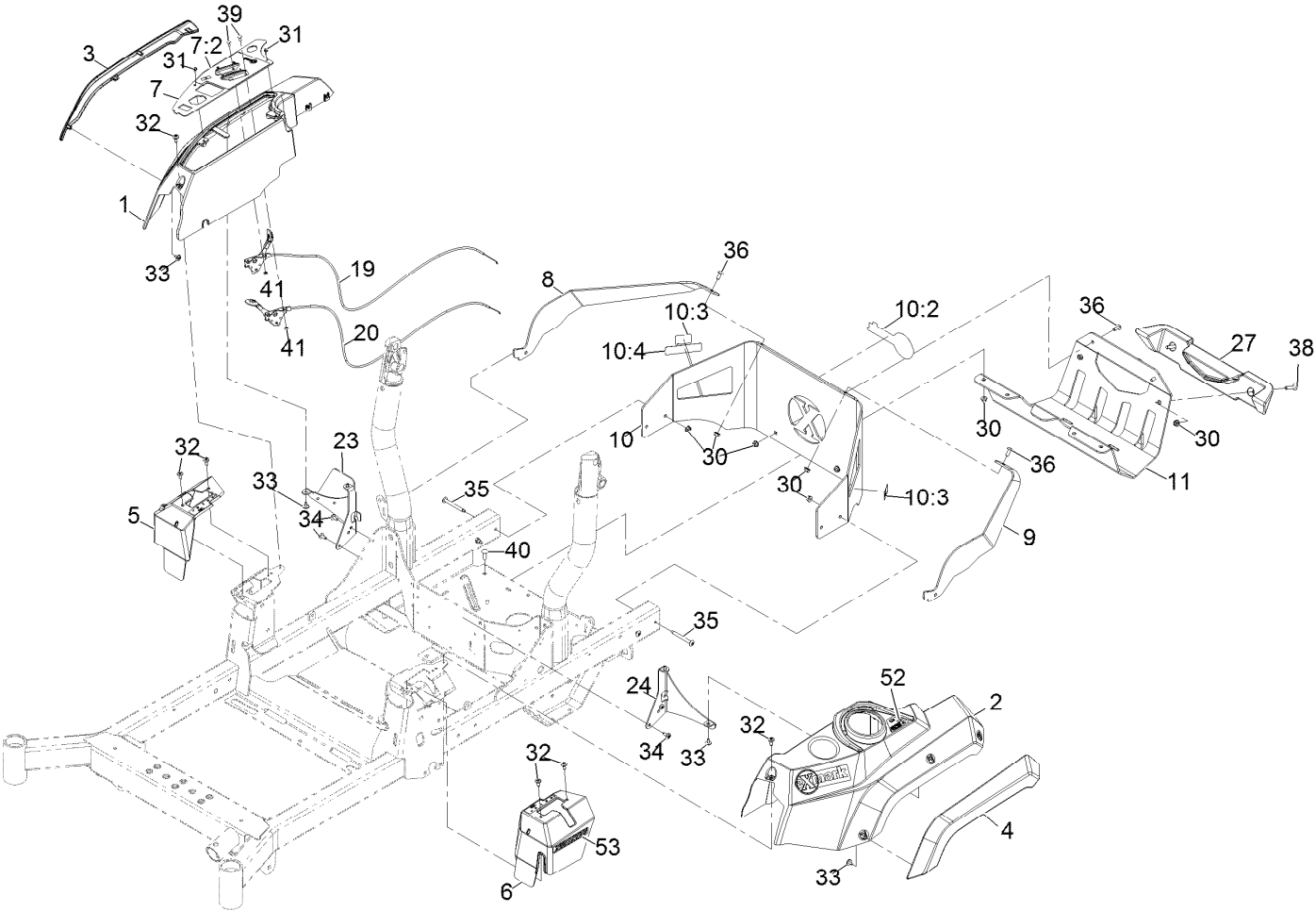

Control Assembly (continued)

<i>Ref.</i>	<i>Part Number</i>	<i>Qty.</i>	<i>Description</i>	<i>Ref.</i>	<i>Part Number</i>	<i>Qty.</i>	<i>Description</i>
1	126-4959	1	Console-Exmark, RH	30	104-8300	12	Nut-Nyloc 5/16-18 Flg
2	126-4960	1	Console, LH	31	117-5036	2	Screw-HWH #10-14 X 1/2
3	126-4741	1	Fender-RH	32	120-7950	6	Screw-1/4-20 X 1/2 Tf Torx Plus
4	126-4742	1	Fender-LH	33	126-5544	10	Screw-HWH #10-14 X 1/2 Torx
5	126-7371	1	Cover-Motion Control, RH	34	126-6266	4	Screw-1/4-20 X .65 Torx Plus
6	126-7372	1	Cover-Motion Control, LH	35	126-6267	4	Screw-Truss HD 5/16-18 X 2 3/4 Torx Plus
7	126-7789	1	Ctrl Panel ASM W/Decal	36	126-6268	4	Screw-Truss HD 5/16-18 X 3/4 Torx Plus
7:2	126-6570	1	Decal-Control Panel	38	126-7439	2	Screw-Truss HD 5-16-18 X 1 1/2 Torx Plus
8	126-6015-03	1	Support-Upper, RH	39	1-807513	4	Bolt-Carriage #10-24 X 1/2
9	126-6016-03	1	Support-Upper, LH	40	3230-22	2	Bolt-Carriage 5/16-18 X 1 Sp
10	126-7802	1	Rear Guard ASM	41	3296-2	4	Nut-Nyloc #10-24
10:2	126-6965	1	Decal-Exmark Logo	52	126-9939	1	Decal-Fuel Fill
10:3	106-5517	2	Decal-Warning, Hot Surface	53	126-9297	2	Decal-X-Series
10:4	117-2718	1	Decal-Arrester, Spark				
11	126-7664-03	1	Guard-Muffler				
19	126-6945	1	Cable-Control, Choke				
20	126-6944	1	Cable-Control, Throttle				
23	126-9945	1	Support-Console, RH				
24	126-5532-03	1	Bracket-Console, LH				
27	126-7418-03	1	Weight				

Motion Control Assembly

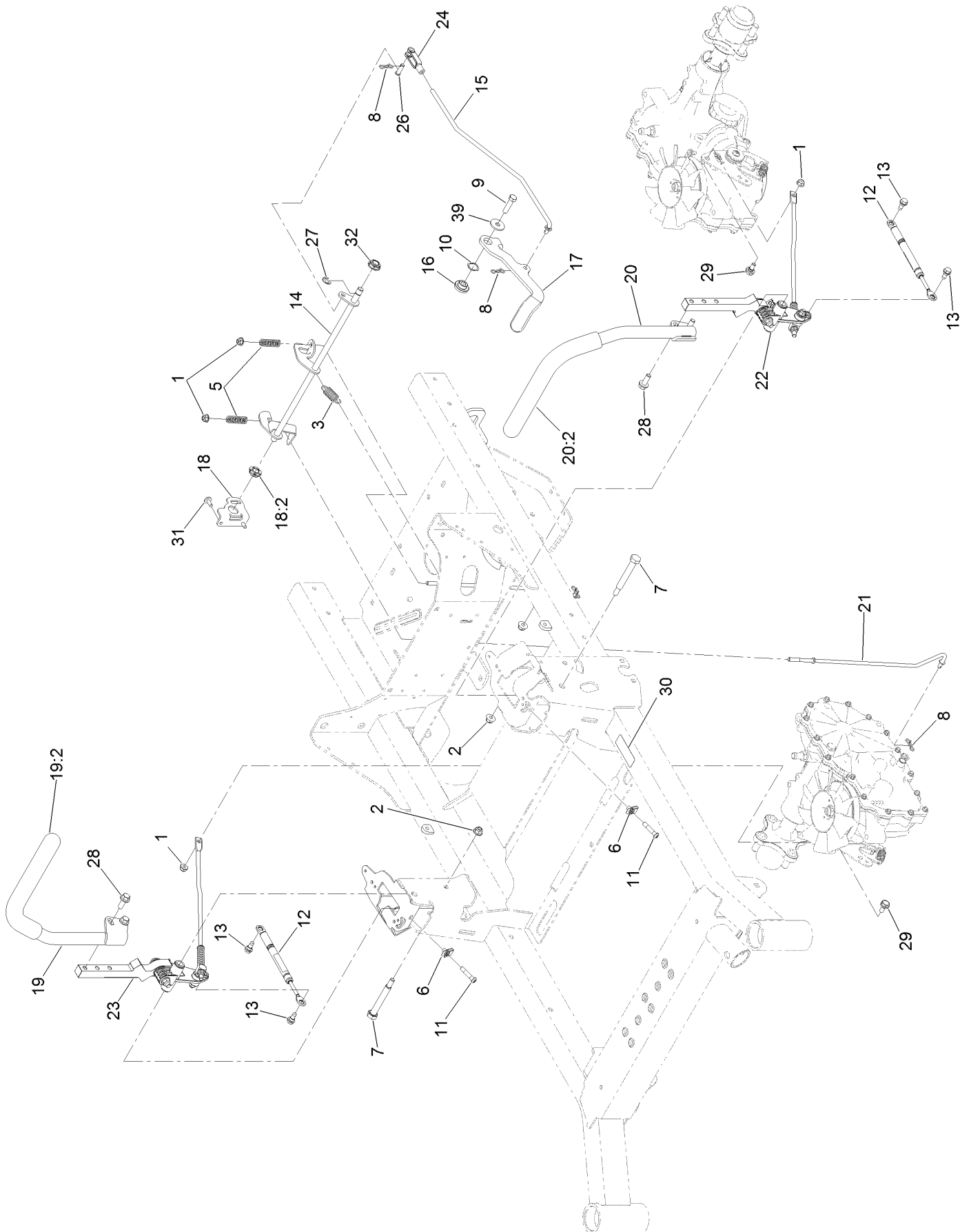

Motion Control Assembly (continued)

<i>Ref.</i>	<i>Part Number</i>	<i>Qty.</i>	<i>Description</i>	<i>Ref.</i>	<i>Part Number</i>	<i>Qty.</i>	<i>Description</i>
1	104-8300	4	Nut-Flange, NI	18:2	126-5820	1	Bearing-Spherical
2	104-8301	3	Nut-Flange, NI	19	126-9191	1	RH Control Handle ASM
3	107-1045	2	Spring-Extension	19:2	126-7359	1	Grip
5	109-7694	2	Spring-Compression	20	126-9192	1	LH Control Handle ASM
6	112-3306	2	Nut	20:2	126-7359	1	Grip
7	115-5099	2	Bolt-Pivot	21	126-7217	2	Linkage, Brake Lower
8	119-1415	4	Pin-Cotter, Locking	22		1	LH Motion Control ASM ●
9	323-8	1	Screw-HH	23		1	RH Motion Control ASM ●
10	119-4164	1	Washer-Wave	24	1-303105	1	Yoke-Adjustable
11	126-4299	2	Screw-HSBH	26	1-808280	1	Pin-Clevis
12	126-4322	2	Damper	27	32120-47	1	Ring-Retaining, External
13	126-4424	4	Screw-Shoulder,HHF,Thd Roll	28	3234-42	4	Screw-HHF
14	126-5813	1	Shaft-Brake	29	37-8771	2	Bolt-Shoulder
15	126-5819	1	Linkage-Brake, Upper	30	115-9625	1	Decal-Brake, Parking
16	126-5989	1	Pivot-Flange	31	126-6266	2	Screw-Torx
17	126-9490	1	Lever-Brake With Grip	32	126-5820	1	Bearing-Spherical
18	126-6456	1	Bracket-Brake, W/Bushing	39	2844	1	Washer

● Not serviced separately

LH Motion Control Assembly

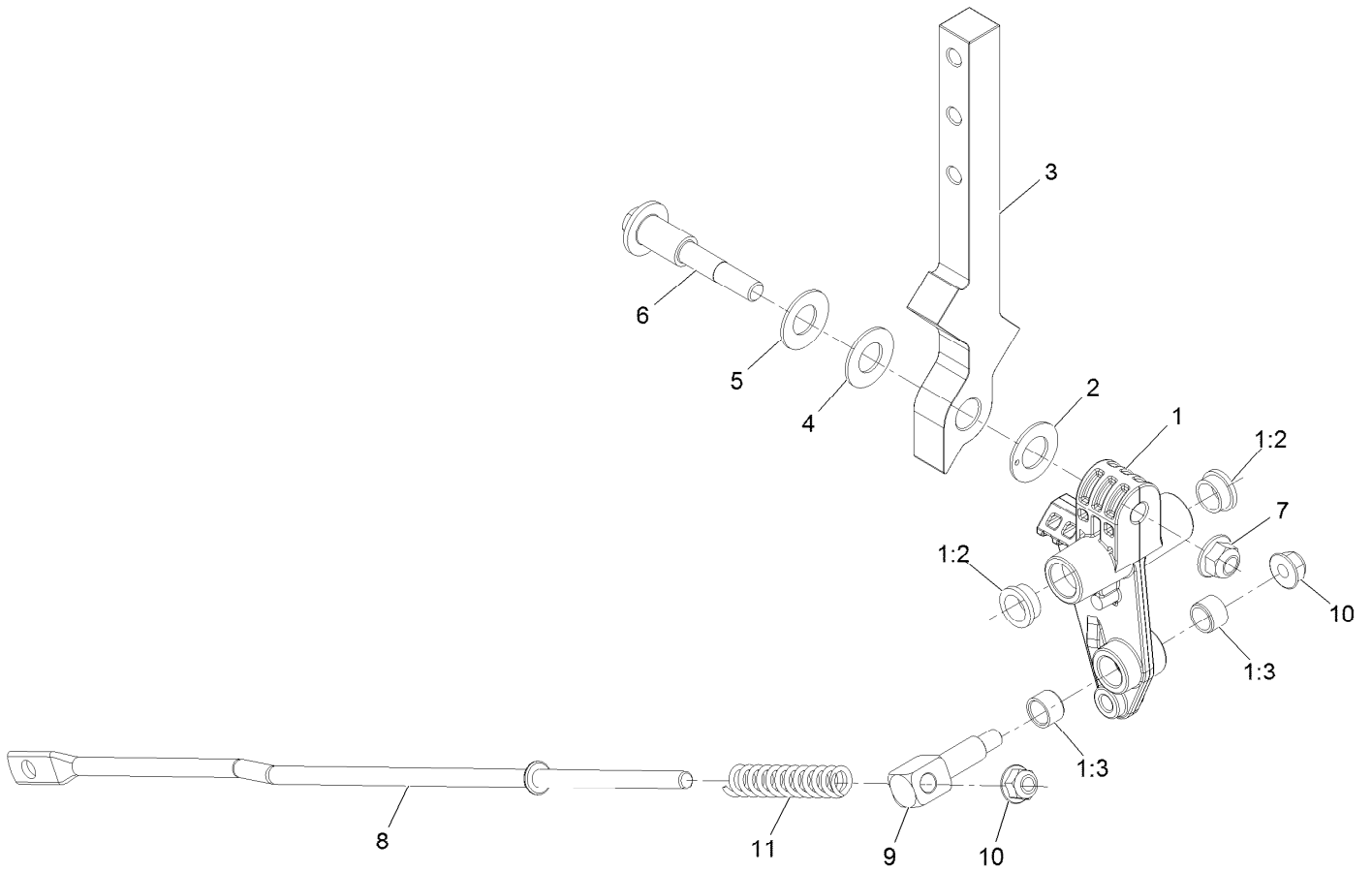

LH Motion Control Assembly (continued)

<i>Ref.</i>	<i>Part Number</i>	<i>Qty.</i>	<i>Description</i>	<i>Ref.</i>	<i>Part Number</i>	<i>Qty.</i>	<i>Description</i>
1	126-3773	1	Control Arm ASM	6	117-1198	1	Bolt-Pivot
1:2	126-8909	2	Bushing-Pm	7	104-8301	1	Nut-Nyloc 3/8-16 Flg
1:3	1-413152	2	Bushing-Sleeve	8	126-5435	1	Link-Control
2	126-7296	1	Washer, Friction	9	126-5434	1	Swivel
3	126-8182	1	Arm-Control	10	104-8300	2	Nut-Nyloc 5/16-18 Flg
4	117-1240	1	Washer	11	126-8195	1	Spring-Return, Neutral
5	119-8925	1	Washer-Belleville				

RH Motion Control Assembly

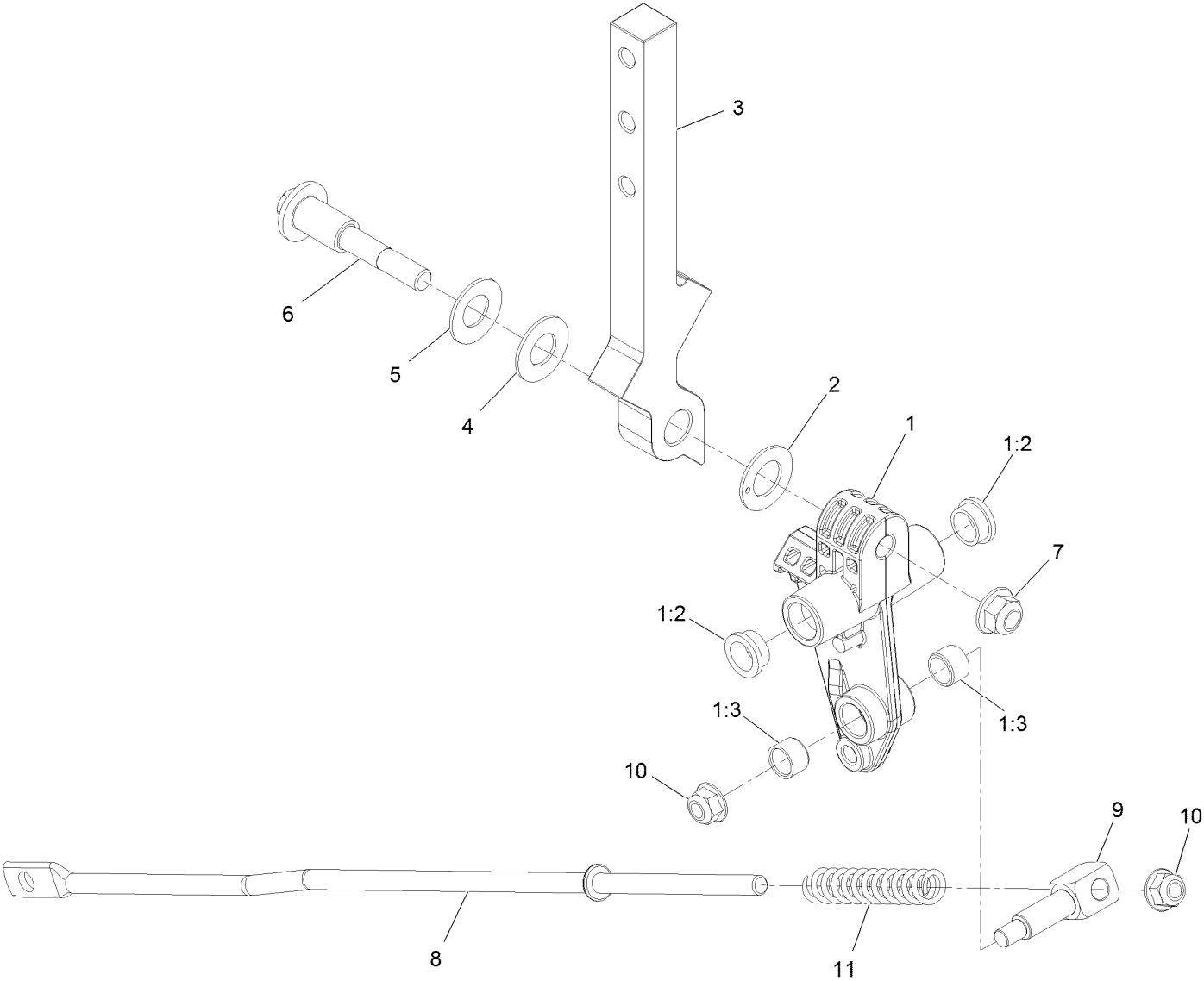

RH Motion Control Assembly (continued)

<i>Ref.</i>	<i>Part Number</i>	<i>Qty.</i>	<i>Description</i>	<i>Ref.</i>	<i>Part Number</i>	<i>Qty.</i>	<i>Description</i>
1	126-3773	1	Control Arm ASM	6	117-1198	1	Bolt-Pivot
1:2	126-8909	2	Bushing-Pm	7	104-8301	1	Nut-Nyloc 3/8-16 Flg
1:3	1-413152	2	Bushing-Sleeve	8	126-5435	1	Link-Control
2	126-7296	1	Washer, Friction	9	126-5434	1	Swivel
3	126-8182	1	Arm-Control	10	104-8300	2	Nut-Nyloc 5/16-18 Flg
4	117-1240	1	Washer	11	126-8195	1	Spring-Return, Neutral
5	119-8925	1	Washer-Belleville				

Fuel Assembly

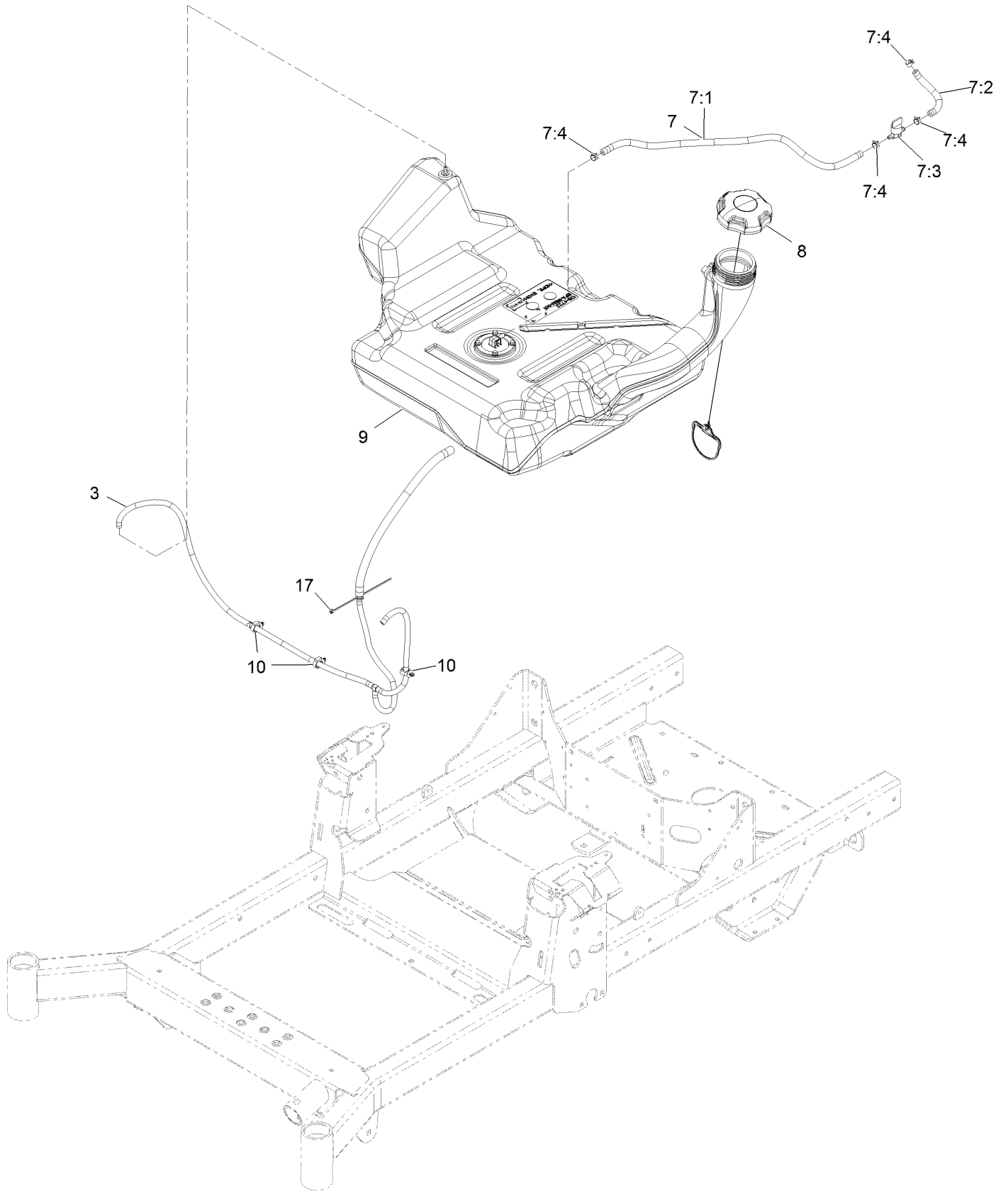

Fuel Assembly (continued)

<i>Ref.</i>	<i>Part Number</i>	<i>Qty.</i>	<i>Description</i>	<i>Ref.</i>	<i>Part Number</i>	<i>Qty.</i>	<i>Description</i>
3	126-8736	1	Vent Hose ASM	7:4	2412-98	4	Clamp-Hose
7	126-8740	1	Fuel Hose ASM	8	126-4723	1	Cap-Fuel
7:1	109-0302	1	Hose-Fuel Line 24"	9	126-4724	1	Fuel Tank ASM
7:2	109-0678	1	Hose-Fuel	10	126-5523	3	Clip
7:3	1-603770	1	Valve-Fuel	17	1-303287	1	Tie-Cable 5 1/2 (Small)

Fuel Tank Assembly (cont.)

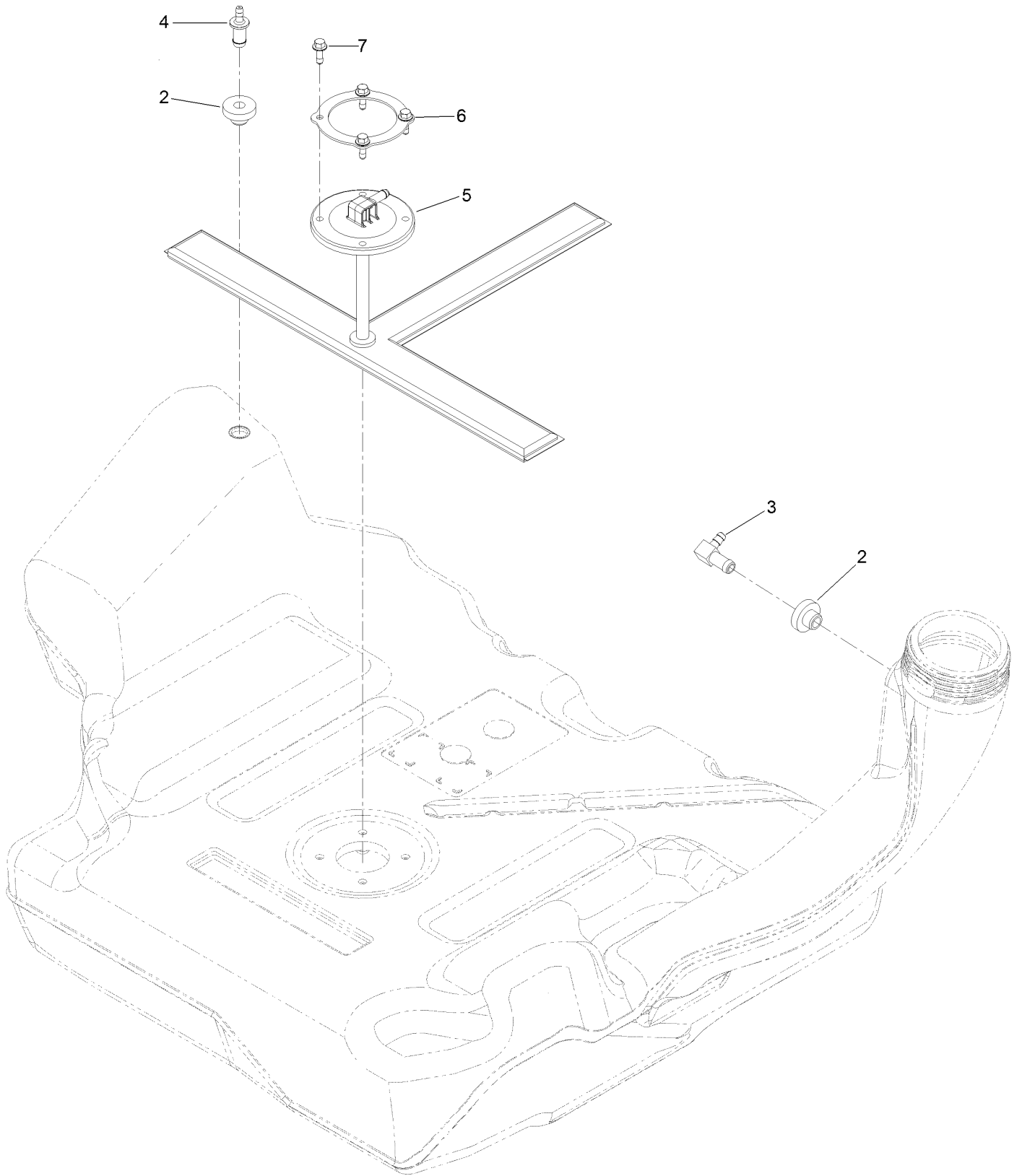

Fuel Tank Assembly (cont.) (continued)

<i>Ref.</i>	<i>Part Number</i>	<i>Qty.</i>	<i>Description</i>	<i>Ref.</i>	<i>Part Number</i>	<i>Qty.</i>	<i>Description</i>
2	46-6560	2	Bushing	5	126-5528	1	Fuel Pickup
3	126-9057	1	Fitting, 90 DEG	6	126-5527	1	Ring-Retainer
4	116-4630	1	Fitting-Straight Orifice	7	126-5525	4	Bolt

Seat Assembly

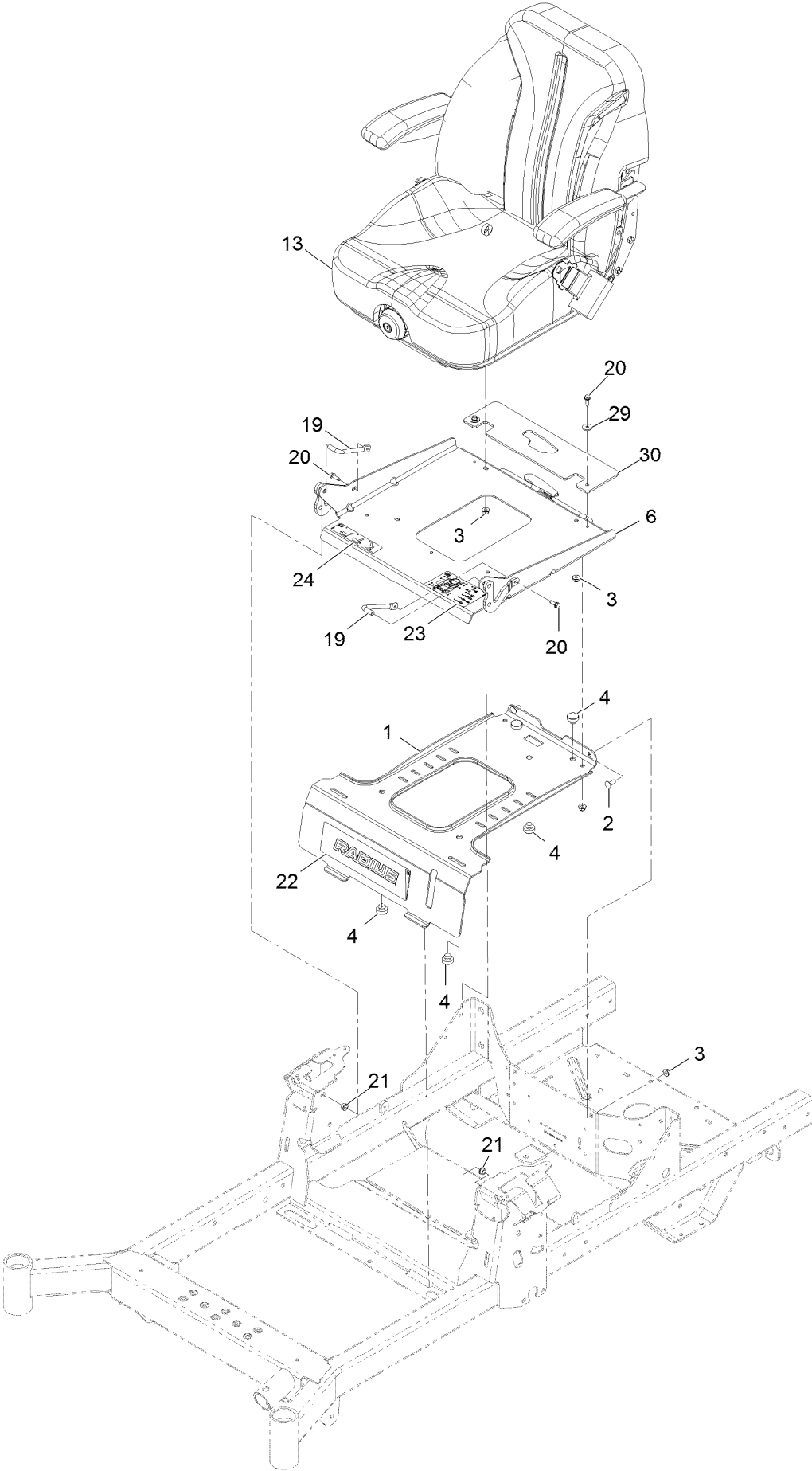

Seat Assembly (continued)

<i>Ref.</i>	<i>Part Number</i>	<i>Qty.</i>	<i>Description</i>	<i>Ref.</i>	<i>Part Number</i>	<i>Qty.</i>	<i>Description</i>
1	126-4082-03	1	Plate-Retainer, Tank	20	32144-44	4	Screw-HWH, Thread Roll
2	3230-23	2	Bolt-Carriage 5/16-18 X 3/4 Short Neck	21	1-603735	2	Bushing-Flanged
3	104-8300	6	Nut-Nyloc 5/16-18 Flg	22	126-9082	1	Decal-Radius Logo
4	104-1412	5	Bumper-Rubber	23	126-8151	1	Decal-Service Aid
6	126-7309	1	Seat Pan And Latch ASM	24	126-8161	1	Decal-Seat Latch
13	126-8292	1	ASM-Susp Seat	29	3256-67	2	Washer-Flat
19	126-5914	2	Pin-Pivot, Seat	30	135-0099	1	Guard-Rubber

Seat Latch Assembly

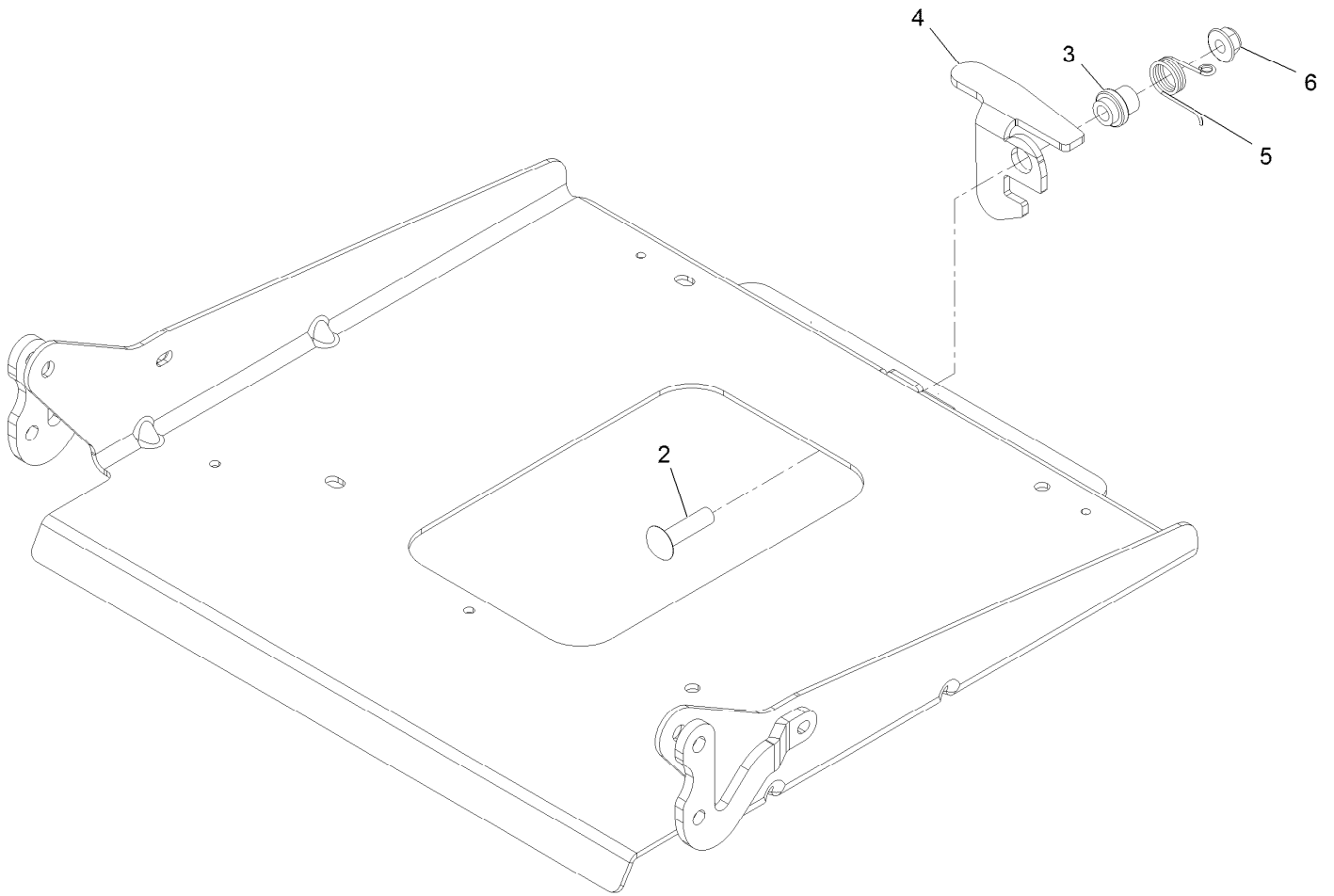

Seat Latch Assembly (continued)

<i>Ref.</i>	<i>Part Number</i>	<i>Qty.</i>	<i>Description</i>	<i>Ref.</i>	<i>Part Number</i>	<i>Qty.</i>	<i>Description</i>
2	3231-26	1	Screw-CARR	5	126-8923	1	Spring-Torsion Latch
3	107-0075	1	Bushing-Latch, Seat	6	104-8301	1	Nut-Flange, NI
4	126-6739	1	Latch-Single Catch				

Seat Assembly (cont)

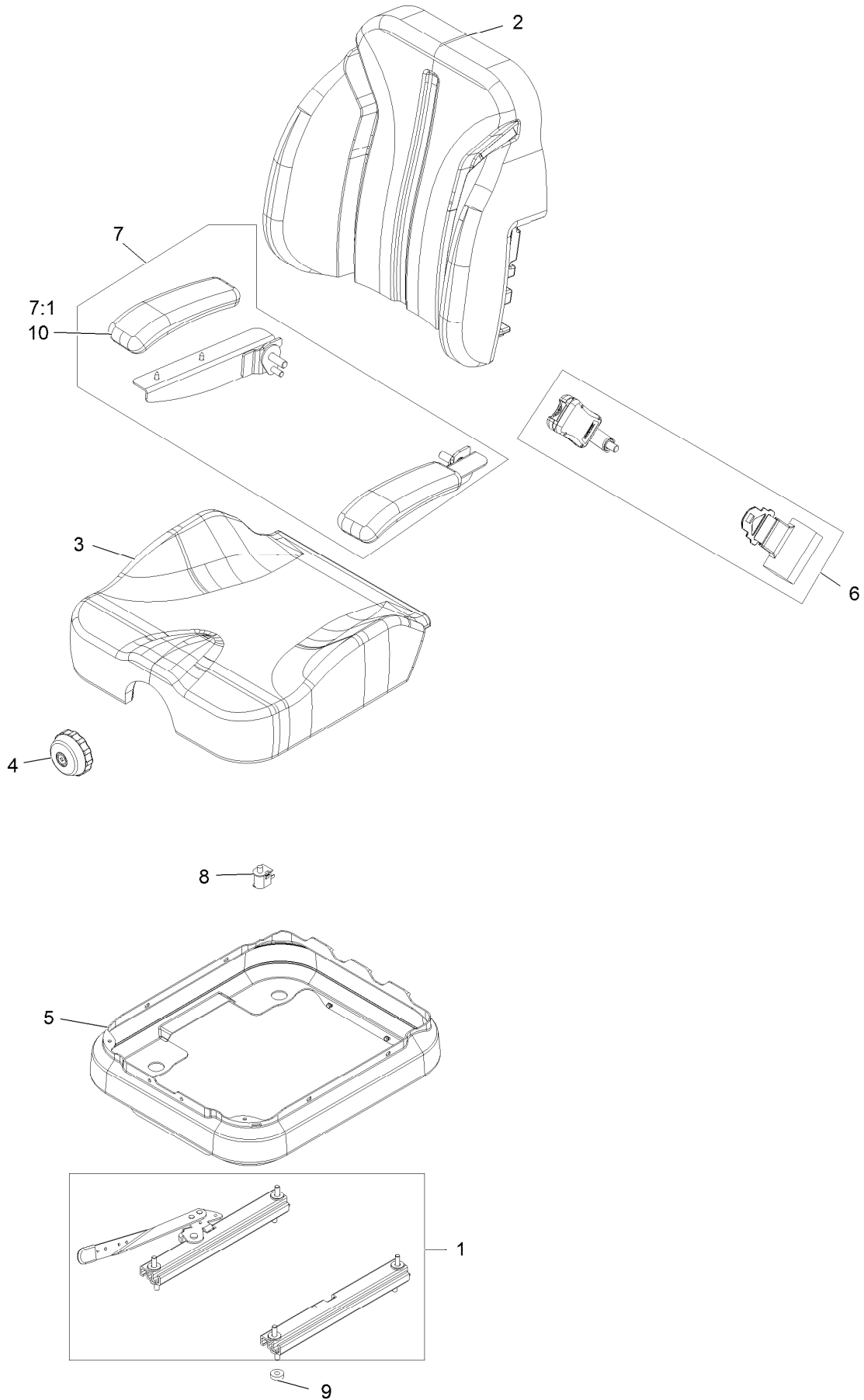

Seat Assembly (cont) (continued)

<i>Ref.</i>	<i>Part Number</i>	<i>Qty.</i>	<i>Description</i>	<i>Ref.</i>	<i>Part Number</i>	<i>Qty.</i>	<i>Description</i>
1	126-8558	1	Tracks-4" Travel	7	126-2058	1	Armrest Kit
2	126-8552	1	Cover-Seat Back Svc	7:1	110-4163	2	Cushion-Rest, Arm
3	126-8551	1	Cover-Seat Bottom Svc	8	82-2190	1	Switch
4	116-8911	1	Knob-Adjuster	9	26-4840	4	Spacer-Pin, Mounting
5	126-8559	1	Bellows-Seat	10	110-4163	2	Cushion-Rest, Arm
6	126-8560	1	Kit-Seat Belt				

Engine Assembly

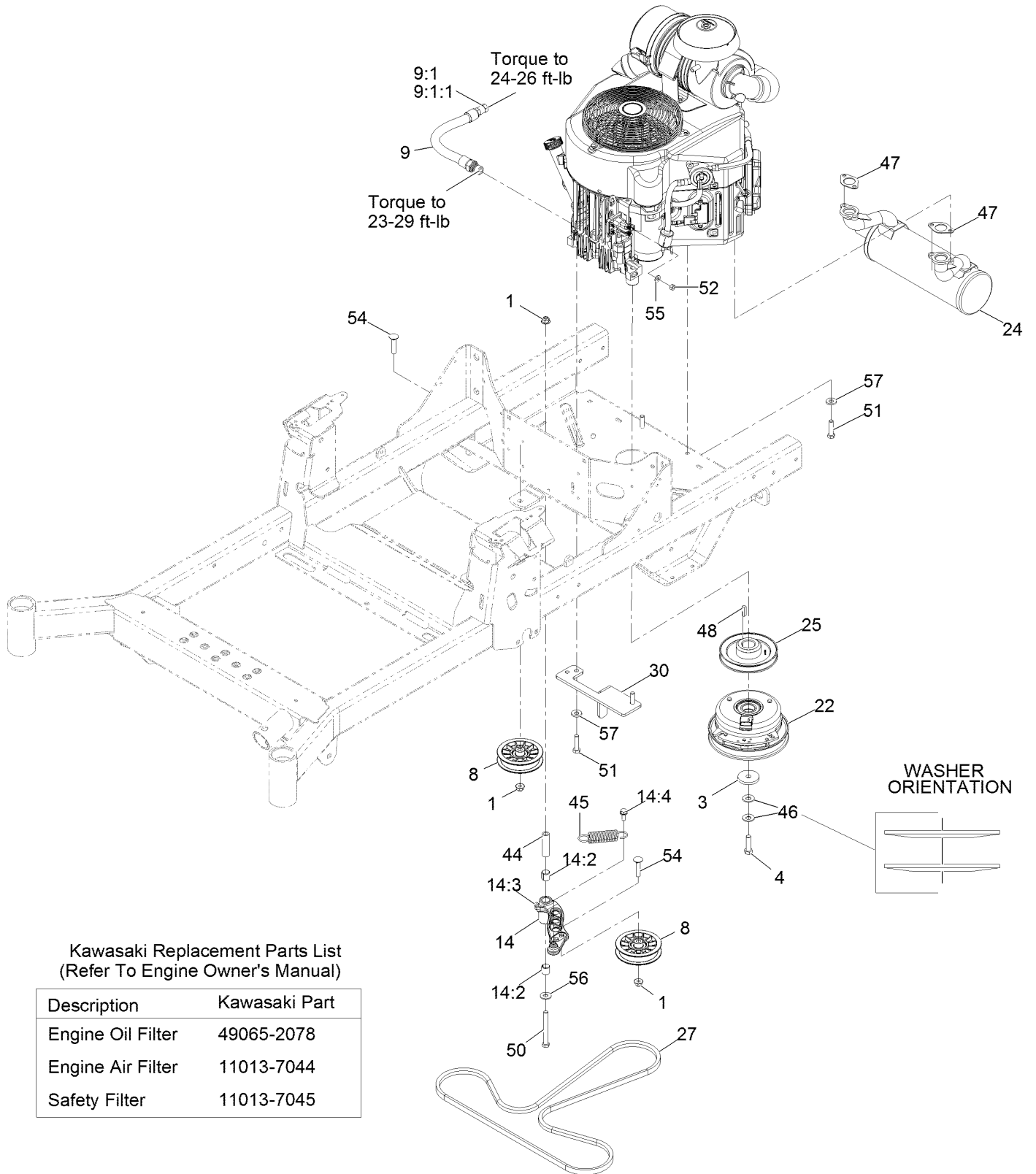

Kawasaki Replacement Parts List
(Refer To Engine Owner's Manual)

Description	Kawasaki Part
Engine Oil Filter	49065-2078
Engine Air Filter	11013-7044
Safety Filter	11013-7045

Engine Assembly (continued)

<i>Ref.</i>	<i>Part Number</i>	<i>Qty.</i>	<i>Description</i>	<i>Ref.</i>	<i>Part Number</i>	<i>Qty.</i>	<i>Description</i>
1	104-8301	3	Nut-Nyloc 3/8-16 Flg	25	126-5358	1	Sheave, W/Hub
3	109-6919	1	Washer-Clutch	27	126-5993	1	Belt-V
4	109-9761	1	Screw-HH 7/16-20 X 1 1/2 W/Loctite ●	30	126-6687-03	1	Anchor Clutch
8	116-2456	2	Pulley-Flat, 3.50 Dia	44	1-603384	1	Bushing-Pivot, Idler
9	116-4924	1	Asm-Hose Oil Drain W/Plug	45	1-603402	1	Spring-Extension
9:1	353-508	1	Plug-W/O-Ring	46	1-603610	2	Washer-Spring Disc 7/16
9:1:1	237-42	1	O-Ring	47	1-653313	2	Gasket-Exhaust
14	126-0973	1	Idler Arm ASM	48	1-807259	1	Key-Machine 1/4 X 1/4 X 1
14:2	1-513034	2	Sleeve-Bearing	50	323-15	1	Screw-HH 3/8-16 X 3 1/2
14:3	302-40	1	Zerk-90° 1/4-28	51	323-8	4	Screw-HH 3/8-16 X 1 1/2
14:4	32144-11	1	Screw-HWH 5/16-18 X 3/4 Tf	52	3217-5	1	Nut-Hex 1/4-20
22	126-4324	1	Clutch 1.13	54	3231-5	2	Bolt-Carriage 3/8-16 X 1 3/4
24	126-4360	1	Muffler-Kawasaki Aes	55	3256-22	1	Washer-1/4 Sae
				56	3256-4	1	Washer-3/8 Std
				57	98-5975	4	Washer-Spring Disc 3/8

● Use Pro-Lock, Nut Type (P/N 1-840022, .5ml tube) on threads.

Hydraulic Assembly

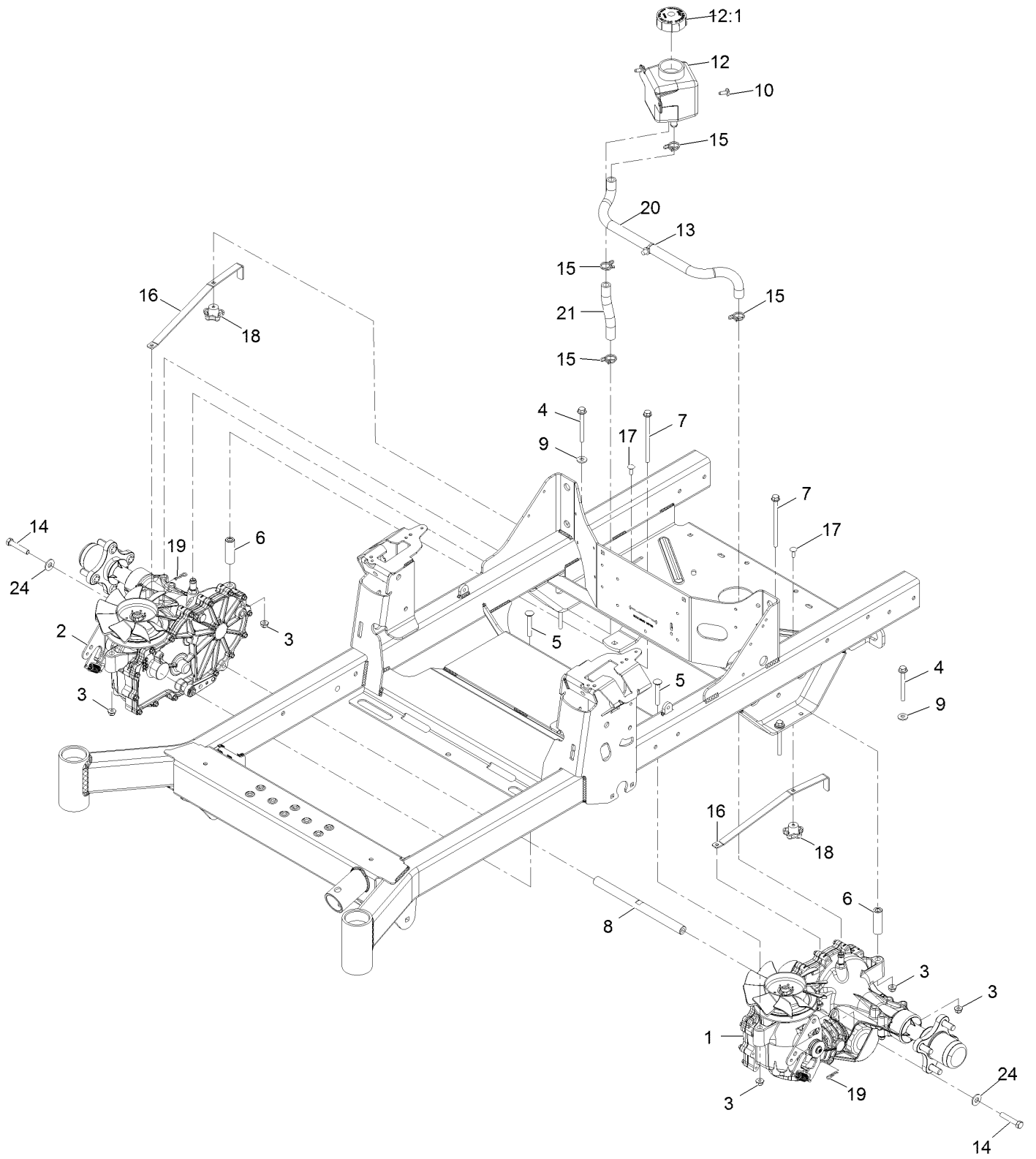

Hydraulic Assembly (continued)

<i>Ref.</i>	<i>Part Number</i>	<i>Qty.</i>	<i>Description</i>	<i>Ref.</i>	<i>Part Number</i>	<i>Qty.</i>	<i>Description</i>
1	126-2883	1	Transaxle ASM	12	109-2250	1	Vent-Tank, HYD
2	126-2884	1	Transaxle ASM	12:1	109-3320	1	Cap-Reservoir, HYD
3	104-8300	8	Nut-Nyloc 5/16-18 Flg	13	32180-118	1	Clip-Tie
4	126-4687	4	Screw-HHF ●	14	94-7972	2	Screw-HH W/Loctite
5	3230-7	2	Bolt-Carriage 5/16-18 X 2 1/4	15	126-0327	4	Clamp-Hose
6	116-5809	2	Spacer-Hydro	16	109-5395	2	Arm-Bypass, Hydro
7	126-5896	2	Screw HHF	17	3229-1	2	Bolt-Carriage 1/4-20 X 3/4
8	116-6833	1	Shaft-Spacer	18	108-6402	2	Knob-Handle
9	1-303334	4	Washer-Spring Disc 5/16	19	1-806003	2	Hairpin-Cotter
10	126-6266	2	Screw-1/4-20 X .65 Torx Plus	20	126-5668	1	Hose-Hydraulic
				21	126-5669	1	Hose-Hydraulic
				24	3256-4	2	Washer-3/8 Std

● Use Pro-Lock, Nut Type (P/N 1-840022, .5ml tube) on threads.

LH Transaxle Assembly

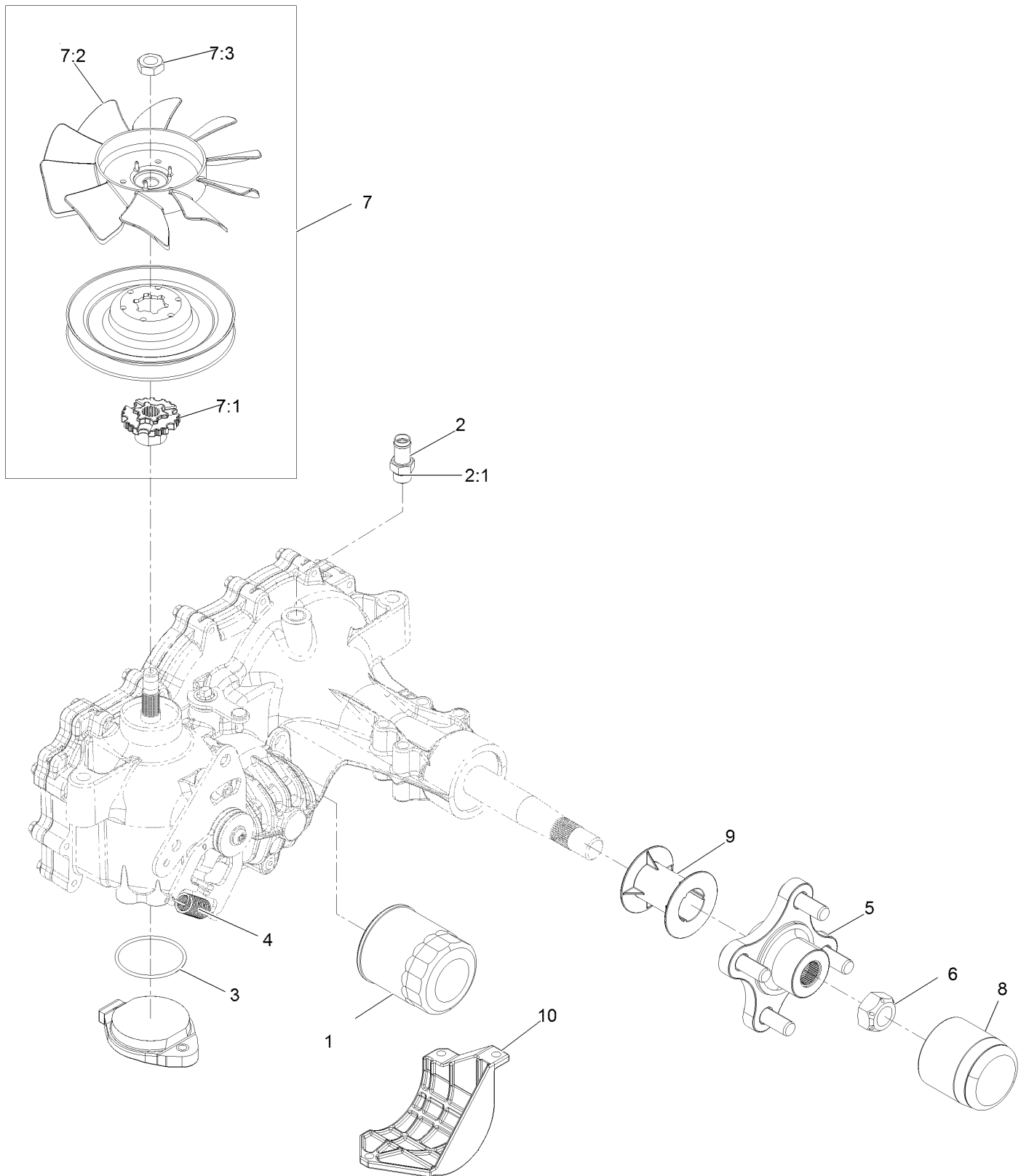

LH Transaxle Assembly (continued)

<i>Ref.</i>	<i>Part Number</i>	<i>Qty.</i>	<i>Description</i>	<i>Ref.</i>	<i>Part Number</i>	<i>Qty.</i>	<i>Description</i>
1	109-3321	1	Filter-Hydraulic	7:1	126-8905	1	Hub-Fan
2	109-3278	1	Adapter-Straight	7:2	126-0226	1	Fan
2:1	237-42	1	O-Ring	7:3	116-9714	1	Nut-HJ
3	109-3540	1	O-Ring-Charge Seal Cover	8	116-6214	1	Cap-Long Axle
4	109-5592	1	Spring	9	116-6213	1	Tube-Axle
5	116-3872	1	Hub-Offset	10	120-7979	1	Guard-Filter, LH
6	109-3536	1	Nut-Hub	11	121-3243	1	Seal Kit ●
7	126-8904	1	Kit,Fan And Pulley				

● Not illustrated

RH Transaxle Assembly

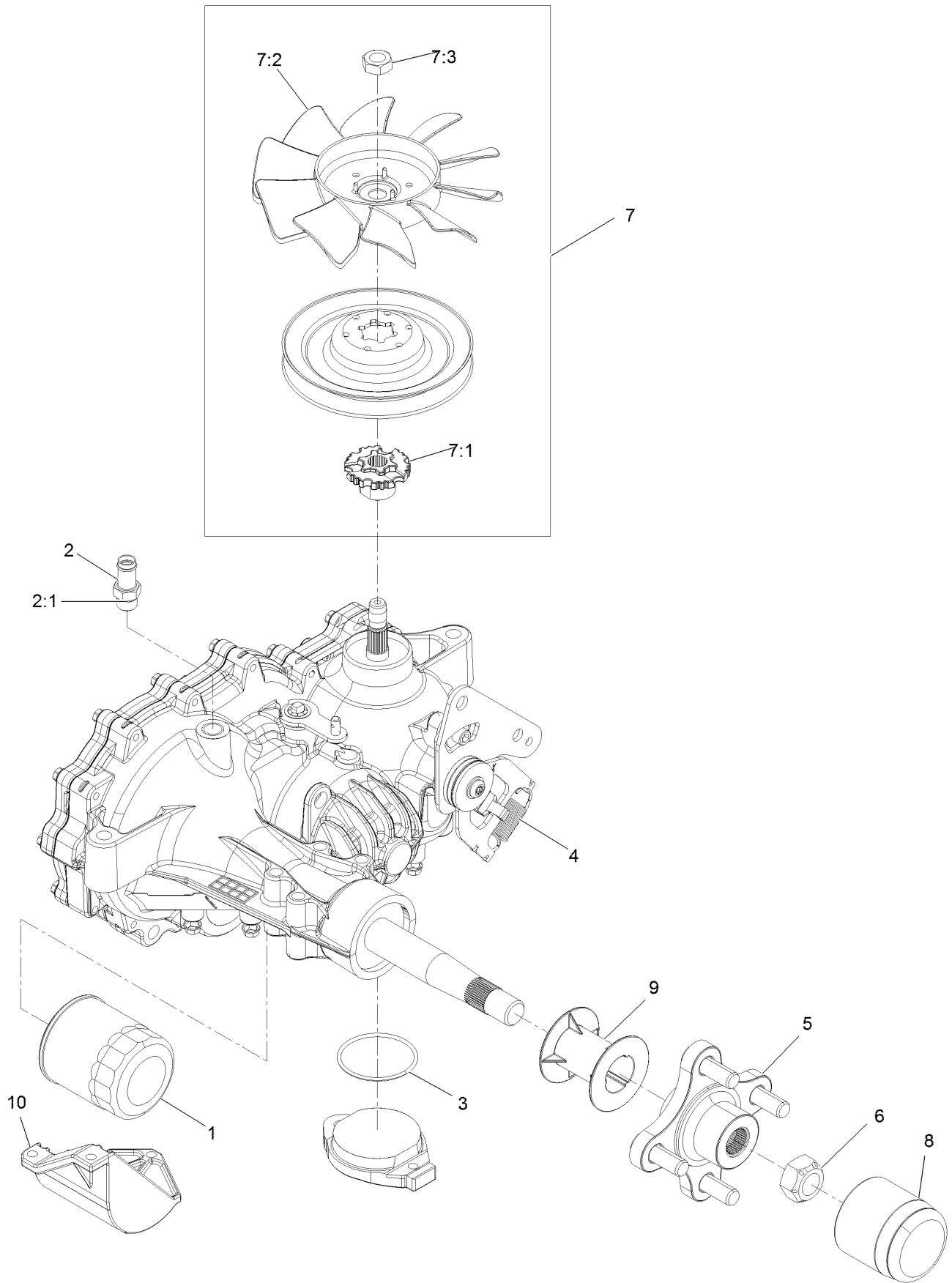

RH Transaxle Assembly (continued)

<i>Ref.</i>	<i>Part Number</i>	<i>Qty.</i>	<i>Description</i>	<i>Ref.</i>	<i>Part Number</i>	<i>Qty.</i>	<i>Description</i>
1	109-3321	1	Element-Oil Filter, HYD	7:1	126-8905	1	Hub-Fan
2	109-3278	1	Adapter-Straight	7:2	126-0226	1	Fan
2:1	237-42	1	O-Ring	7:3	116-9714	1	Nut-HJ
3	109-3540	1	O Ring-Seal	8	116-6214	1	Cap-Long Axle
4	109-5592	1	Spring-Extension	9	116-6213	1	Tube-Axle
5	116-3872	1	Hub-Offset	10	120-7981	1	Guard-Filter, RH
6	109-3536	1	Nut-Hub	11	121-3243	1	Seal Kit ●
7	126-8904	1	Kit,Fan And Pulley				

● Not illustrated

Electrical Assembly

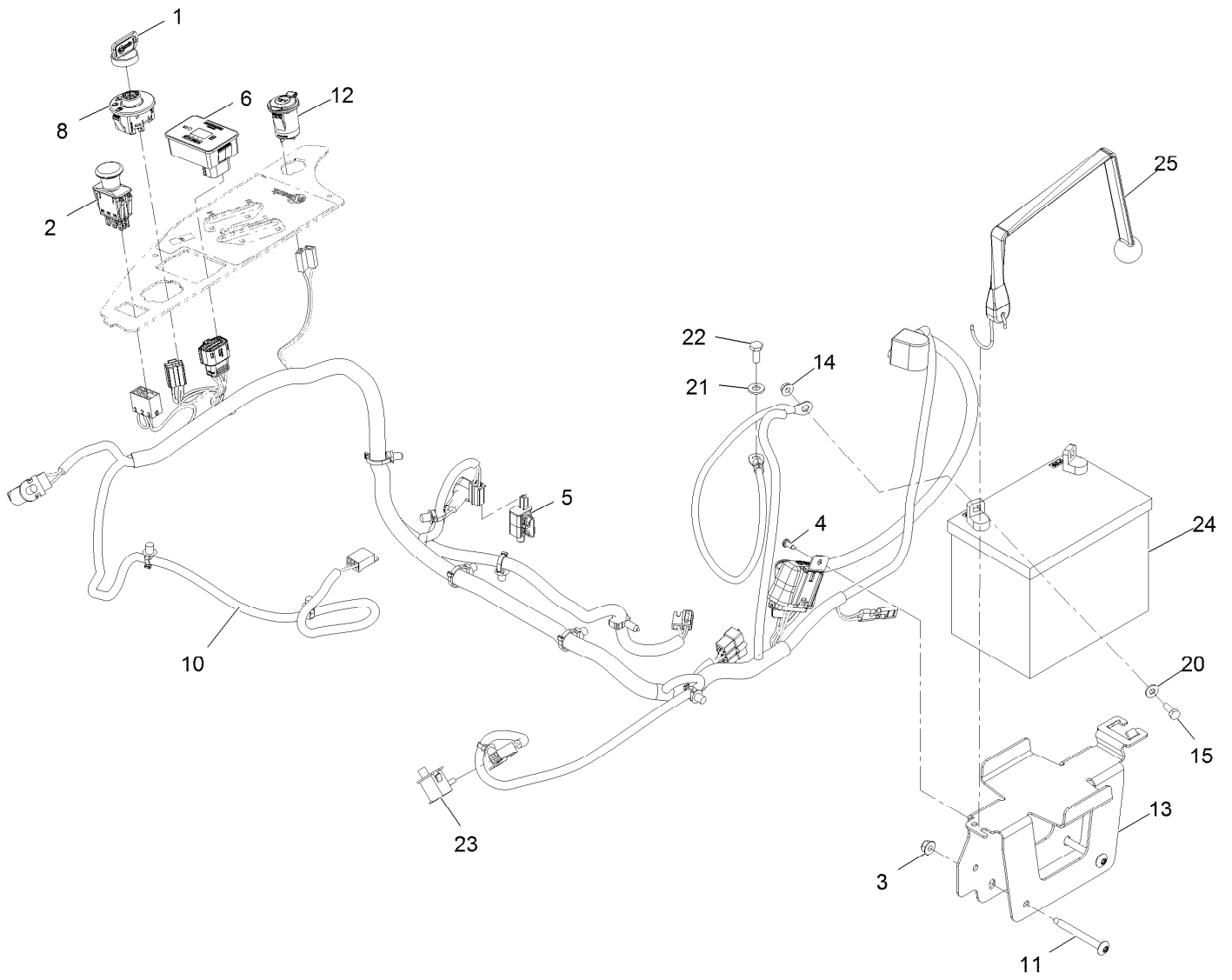

Electrical Assembly (continued)

<i>Ref.</i>	<i>Part Number</i>	<i>Qty.</i>	<i>Description</i>	<i>Ref.</i>	<i>Part Number</i>	<i>Qty.</i>	<i>Description</i>
1	1-603511	1	Key-Ignition	12	126-6499	1	Port-Power, 12V
1	103-2106	1	Key-Exmark Logo	13	126-6725-03	1	Tray - Battery
2	103-5221	1	Switch-PTO	14	32128-33	2	Nut-Whizlock 1/4-20
3	104-8300	2	Nut-Nyloc 5/16-18 Flg	15	321-4	2	Screw-HH 1/4-20 X 3/4
4	105-6849	1	Screw-Tph #10-24 X 1/2 Tf	20	3256-22	2	Washer-1/4 Sae
5	110-6765	1	Switch	21	33094-00	1	Washer
6	116-5609	1	Module ASM	22	33114-020	1	Screw-HH M8-1.25 X 20Mm
8	117-2221	1	Switch-Ignition	23	82-2190	2	Switch
10	126-5803	1	Harness-Wire ■	24		1	Battery (300 Cca, Wet) ●
11	126-6267	2	Screw-Truss HD 5/16-18 X 2 3/4 Torx Plus	25	126-7627	1	Bungee Strap

● Not serviced separately

■ Use dielectric grease on all unsealed connectors and terminals only. Do not apply in sealed connectors.

Harness Assembly

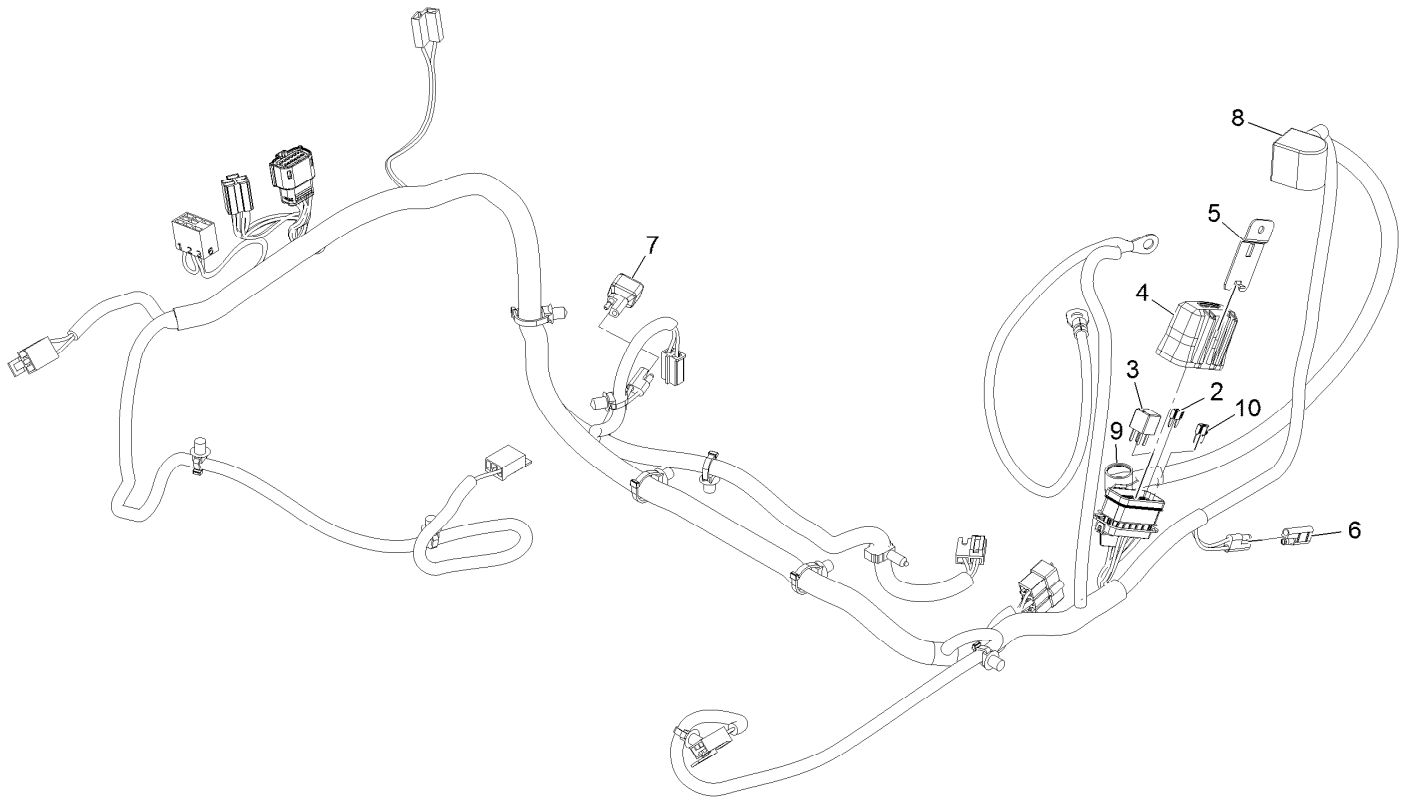

Harness Assembly (continued)

<i>Ref.</i>	<i>Part Number</i>	<i>Qty.</i>	<i>Description</i>	<i>Ref.</i>	<i>Part Number</i>	<i>Qty.</i>	<i>Description</i>
2	121-8868	1	Fuse-Mini Blade, 20 Amp	7	103-3895	1	Diode
3	126-3991	1	Relay-Micro	8	126-8876	1	Insulator-Battery
4	32180-176	1	Cover-Block, Fuse	9	1-543393	1	Insulator-Solenoid
5	32180-177	1	Clip-Mounting	10	121-8867	1	Fuse-Mini Blade, 15 Amp
6	116-0053	1	Cap-Plug				

Notes:

Notes:

Notes:



MAXIMIZE THE PERFORMANCE OF YOUR EXMARK MACHINE.



EXMARK® PREMIUM ENGINE OIL

Exmark now offers a family of engine oil viscosities to perform well in any environment. Each viscosity has the same synthetic formulation to give you what you need in punishing conditions. We designed each grade to the highest quality, making it ideal even for diesel applications. Coupled with Exmark Premium Fuel Treatment, we have the performance products to make your machine hum.

EXMARK PREMIUM ENGINE OIL SAE 30/10W-30

- Meets zero shear requirements of a straight grade SAE 30 as well as the cold temp properties of a 10W-30.
- Most versatile oil in the industry.
- Superior corrosion protection over conventional oil - even in corrosive, humid environments.

EXMARK PREMIUM ENGINE OIL SAE 20W-50

- Perfect for your big block engine, or any application in severe service.
- Same full synthetic formulation as all other Exmark Premium viscosities.
- Also effective for use in severe service small block engines.

EXMARK PREMIUM ENGINE OIL SAE 10W-50

- Full synthetic formulation gives you peak performance. Don't settle for less.
- Wide span multi-grade combines easy starting in cold weather with maximum protection in high temperature operation.
- Reduce friction & wear over standard mineral formulations.

EXMARK PREMIUM ENGINE OIL SAE 0W-40

- The perfect choice for when the weather turns cold or unpredictable, and your Exmark UTV has to perform.
- Commercial quality for severe service.
- Advanced additive package helps prevent corrosion from long-term storage.

EXMARK PREMIUM ENGINE OIL UTV FORMULATION

- 4-cycle high-temp formulation.
- Heavier viscosity, full synthetic, perfect for your UTV.

EXMARK PREMIUM UTV EXTREME CONDITIONS GEAR OIL

- SAE 80W-90, designed to keep your UTV performing at its peak.
- Shear stable, hypoid gear lube.
- Includes a premium additive system to combat wear, oxidation, rust & corrosion.

Available from your local Exmark dealer. Find your closest dealer at exmark.com

EXMARK ACCESSORIES AND OPTIONS*

MID-MOUNT RIDING ACCESSORIES AND OPTIONS

CUSTOM RIDE SEAT SUSPENSION SYSTEM	OPERATOR CONTROLLED DISCHARGE
FULL SUSPENSION SEAT	SUN SHADE
DECK LIFT ASSIST KIT	TRASH CONTAINER
HITCH KIT	TURF STRIPER
LIGHT KIT	ULTRA VAC COLLECTION SYSTEM
12V POWER PORT	ULTRA VAC QUICK DISPOSAL SYSTEM
MICRO-MULCH SYSTEM	

OUT-FRONT RIDING ACCESSORIES AND OPTIONS

CUSTOM RIDE SEAT SUSPENSION SYSTEM	SNOW BLADE
DUAL-TAIL WHEEL	SNOWBLOWER
FLOOR PAN EXTENDER	SUN SHADE
HITCH KIT	TRASH CONTAINER
LIGHT KIT	ULTRA VAC COLLECTION SYSTEM
MICRO-MULCH SYSTEM	ULTRA VAC QUICK DISPOSAL SYSTEM
ROLL OVER PROTECTION SYSTEM (ROPS)	WEATHER CAB

WALK-BEHIND ACCESSORIES AND OPTIONS

GRASS CATCHER	TURF STRIPER
MICRO-MULCH SYSTEM	STANDON

*Some accessories and options not available for some models.

Place Model No. and Serial No.
Label Here (Included in the Literature
Pack) or Fill in Below

Model No. _____

Serial No. _____

Date Purchased _____

Engine Model No. and Spec. No. _____

Engine Serial No. (E/No) _____

© 2016 Exmark Mfg. Co., Inc.
Industrial Park Box 808
Beatrice, NE 68310
All Rights Reserved

Part No. 4502-919 Rev. A
(402) 223-6375
Fax (402) 223-5489
Printed in the USA.

