



# **RADIUS® E-SERIES**

Model No. RAE708GEM52300—Serial No. 40000000 and Up

Picture below may not reflect actual product.



# **Parts Manual**

Part No. 4502-912 Rev. B

# Ordering Replacement Parts

To order replacement parts, please supply the part number, the quantity, and the description of each part desired.

## Understanding Reference Numbers

Each identified part in an illustration has a reference number. The reference number for a part also appears in the parts list, along with other information about the part.

This catalog uses two special reference number formats, one to indicate parts in a service assembly and another to indicate the quantity of a given part in an illustration.

## Service Assembly Reference Numbers

Parts in service assemblies have reference numbers in the form a:b. The a represents the reference number of the entire service assembly and the b represents a sequential number unique to each part within the service assembly.

For example, a wheel assembly might be identified by reference number 6, the tire by 6:1, the valve by 6:2, and the wheel by 6:3. When you order the assembly identified by reference number 6, you receive all parts identified by reference numbers 6:1, 6:2, and 6:3. However, you may also order any part individually. Reference numbers of this type appear in illustration and in parts lists.

## Reference Numbers Indicating Quantity

In an illustration, if a reference number indicates more than one part, the reference number has the form nX y. The n represents the quantity of the part, the X is the multiplication symbol, and the y represents the reference number.

For example, in an illustration, the reference number 2X 37 means that two of the parts identified by reference number 37 are indicated.

# Touch Up Paint

Exmark black touch up spray paint – gloss black.

Exmark red touch up paint (spray paint – P/N 1-850337 - .6 oz liquid bottle – P/N 103-9140).



If your Exmark dealer does not have the Exmark part in stock, Exmark will get the parts to the dealer the next business day or the part will be FREE Guaranteed!! (Some restrictions apply. See your participating Exmark Dealer for details.)

## Contents

Complete Deck Assembly . . . . .	4
Deck Assembly . . . . .	6
Deck W/Decals Assembly No. 126-3578 . . . . .	8
Idler Arm W/Bearings Assembly . . . . .	10
Main Frame Assembly . . . . .	12
Caster Wheel Assembly . . . . .	14
Roll-Over Protection System Assembly . . . . .	16
Deck Lift Assembly . . . . .	18
Deck Strut Assembly . . . . .	20
Controls Assembly . . . . .	22
Motion Control Assembly . . . . .	24
LH Motion Control Assembly . . . . .	26
RH Motion Control Assembly . . . . .	28
Fuel Assembly . . . . .	30
Fuel Tank Assembly (cont.) . . . . .	32
Seat Assembly . . . . .	34
Seat Assembly (cont.) . . . . .	36
Fuel System Assembly . . . . .	38
Carburetor Assembly . . . . .	40
Engine Assembly . . . . .	42
Air Intake and Filtration Assembly . . . . .	44
Ignition and Electrical Assembly . . . . .	46
Crankcase and Crankshaft Assembly . . . . .	48
Governor Control Assembly . . . . .	50
Piston and Cylinder Head Assembly . . . . .	52
Blower Housing Assembly . . . . .	54
Gasket and Seal Kit . . . . .	56
Hydro Transaxle Drive Assembly . . . . .	58
LH Transaxle Assembly . . . . .	60
RH Transaxle Assembly . . . . .	62
Electrical Assembly . . . . .	64
Harness Assembly . . . . .	66

# Complete Deck Assembly

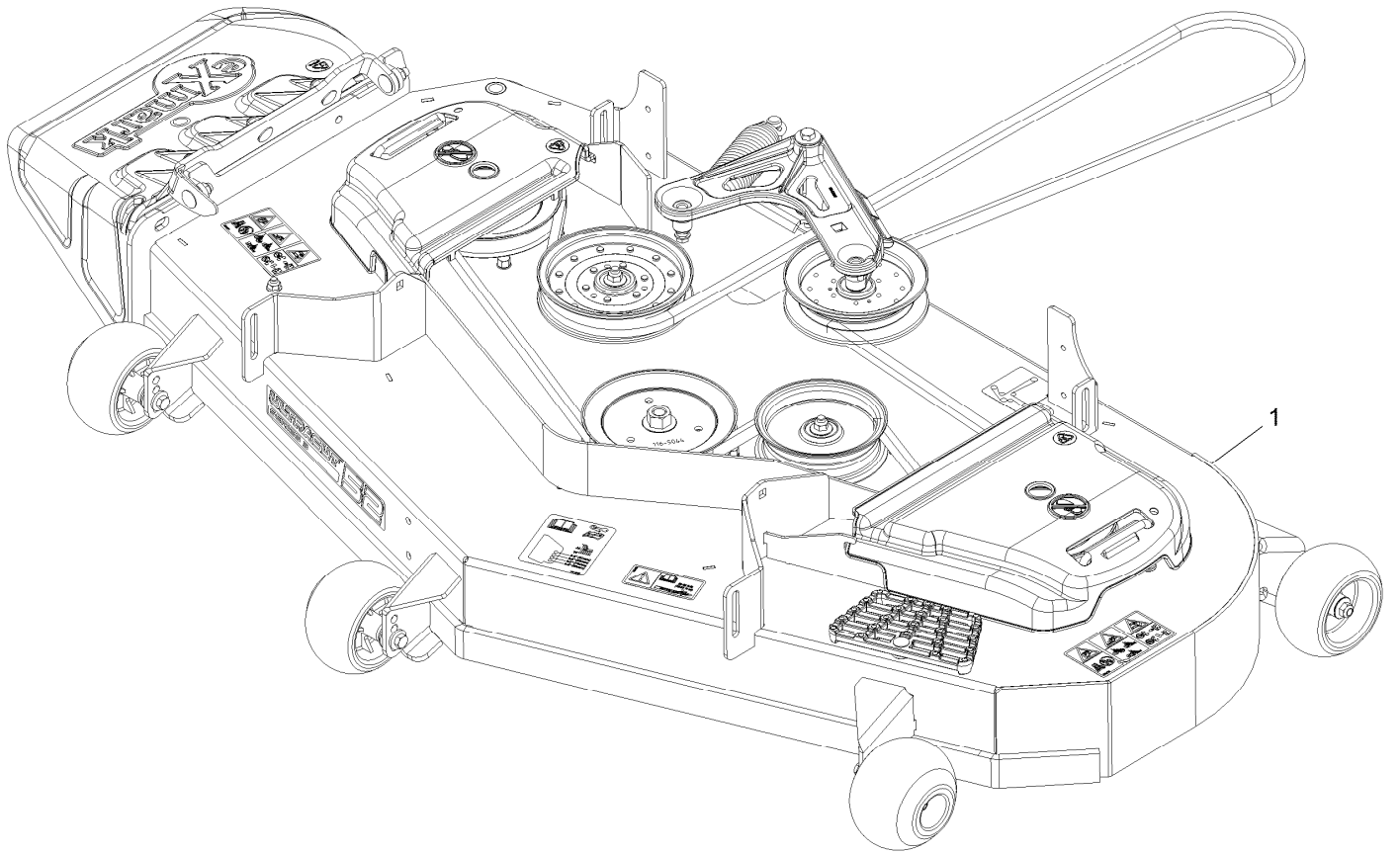

# Complete Deck Assembly (continued)

<i>Ref.</i>	<i>Part Number</i>	<i>Qty.</i>	<i>Description</i>
1	126-8038	1	ASM-Deck Complete 523

# Deck Assembly

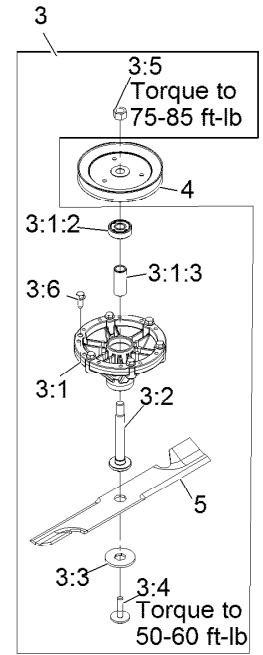
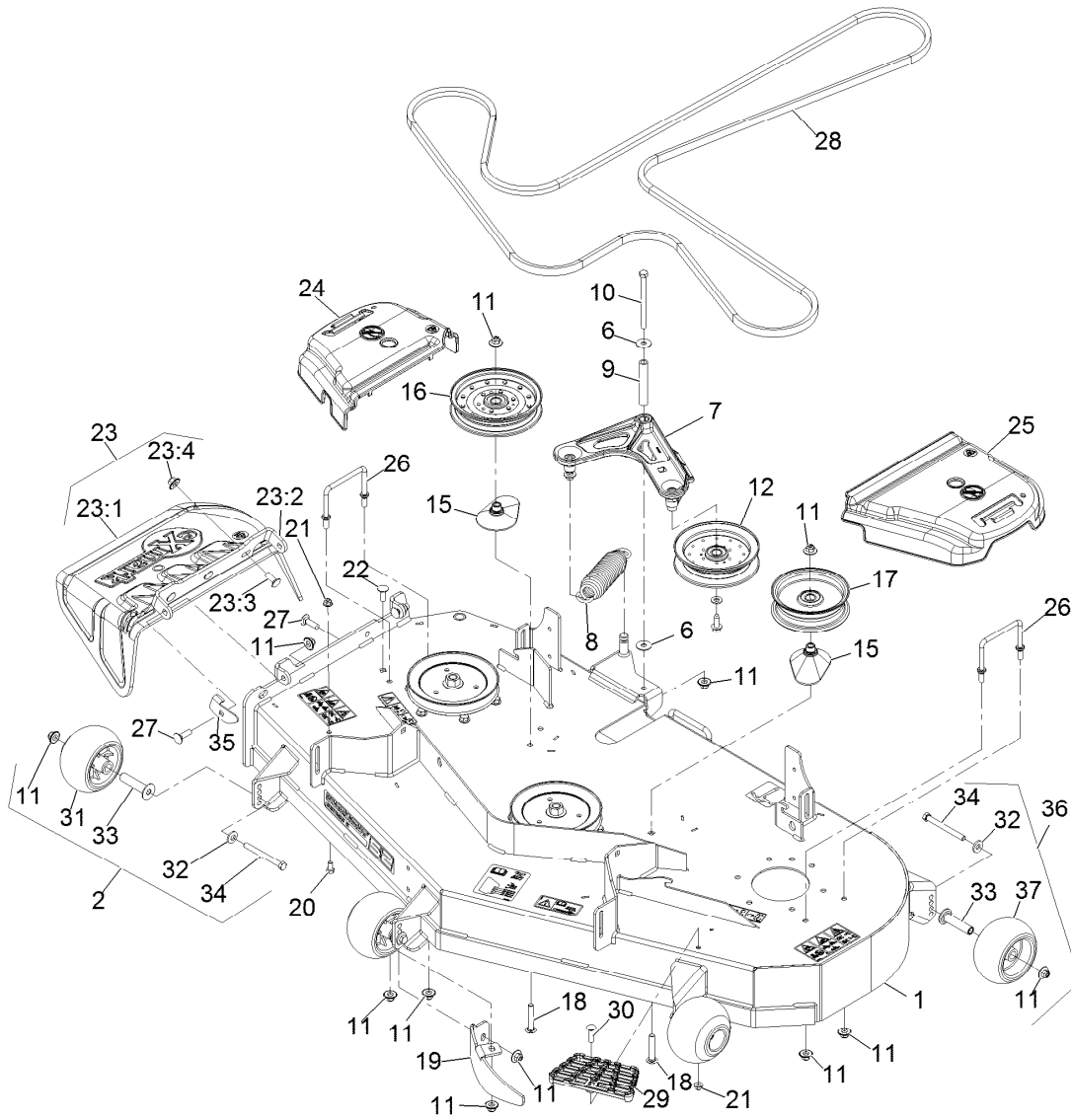

## Deck Assembly (continued)

<i>Ref.</i>	<i>Part Number</i>	<i>Qty.</i>	<i>Description</i>	<i>Ref.</i>	<i>Part Number</i>	<i>Qty.</i>	<i>Description</i>
1	126-3578	1	ASM-Deck W/Decals 523	17	116-4669	1	Idler-Pulley, Flat
2	116-9981	3	Kit, Anti-Scalp Roller	18	3231-40	2	Bolt-Carriage 3/8-16 X 2 1/4
3	126-4630	3	ASM, Cutter Housing Complete	19	116-5835-01	1	Baffle-Dogleg, Lze-Pns-52
3:1	126-4627	1	ASM-Cutter Housing	20	322-2	1	Screw-HH 5/16-18 X 5/8
3:1:2	116-4004	2	Bearing	21	104-8300	2	Nut-Nyloc 5/16-18 Flg
3:1:3	116-4876	1	Spacer-Bearing	22	3231-22	1	Bolt-Carriage 3/8-16 X 1
3:2	109-7431	1	Spindle-Hex Pilot	23	109-7188	1	ASM,Discharge Chute
3:3	126-4530	1	Washer-Hex Blade Drive	23:1	109-2738	1	Chute, Discharge
3:4	116-0005	1	Bolt-Blade, Sem	23:2	109-8675-01	1	Bracket,Discharge Chute
3:5	3219-6	1	Nut-Hex 5/8-18	23:3	3231-22	3	Bolt-Carriage 3/8-16 X 1
3:6	126-1696	6	Screw-Forming, Thread	23:4	109-6658	3	Nut-Nyloc 3/8-16 Flg
4	116-5044	3	Sheave,Blade Drive 6.50	24	109-6935	1	Cover-Belt, RH
5	103-6387	3	Blade, Low Lift	25	109-6936	1	Cover-Belt, LH
5	103-6382	3	Blade, Solid	26	109-6982	2	Wireform-Cover
5	103-6392	3	Blade, Mulching ●	27	3231-25	3	Bolt-Carriage 3/8-16 X 1 1/4
5	103-6402	3	Blade-Notched	28	126-7443	1	Belt-V
5	116-5175	3	Blade-Extreme 2, 18.00"	29	126-4781-03	1	Step-Deck
6	52-2860	2	Washer	30	3230-3	1	Bolt-Carriage 5/16-18 X 1 1/4
7	126-0976	1	Idler Arm ASM	31	103-8415	3	Roller-Anti-Scalp
8	116-6317	1	Spring-Extension	32	98-5975	5	Washer-Spring Disc 3/8
9	116-5111	1	Bushing	33	116-8131	5	Axle, Roller
10	323-38	1	Screw-HH 3/8-16 X 4 3/4	34	116-9362	5	Screw-HH 3/8-16 X 3 3/4 GR 8
11	109-6658	16	Nut-Nyloc 3/8-16 Flg	35	135-0064	1	Stop-Discharge Chute
12	116-4668	1	Idler-Pulley, Flanged	36	126-7840	2	Kit-Antiscalp Roller
15	109-2872	2	Spacer-Pulley	37	1-603299	2	Roller-Scalp, Anti
16	116-4670	1	Pulley-Idler, Flat				

● Requires installation of mulch kit for proper mulching. See your Exmark dealer for details.

# Deck W/Decals Assembly No. 126-3578

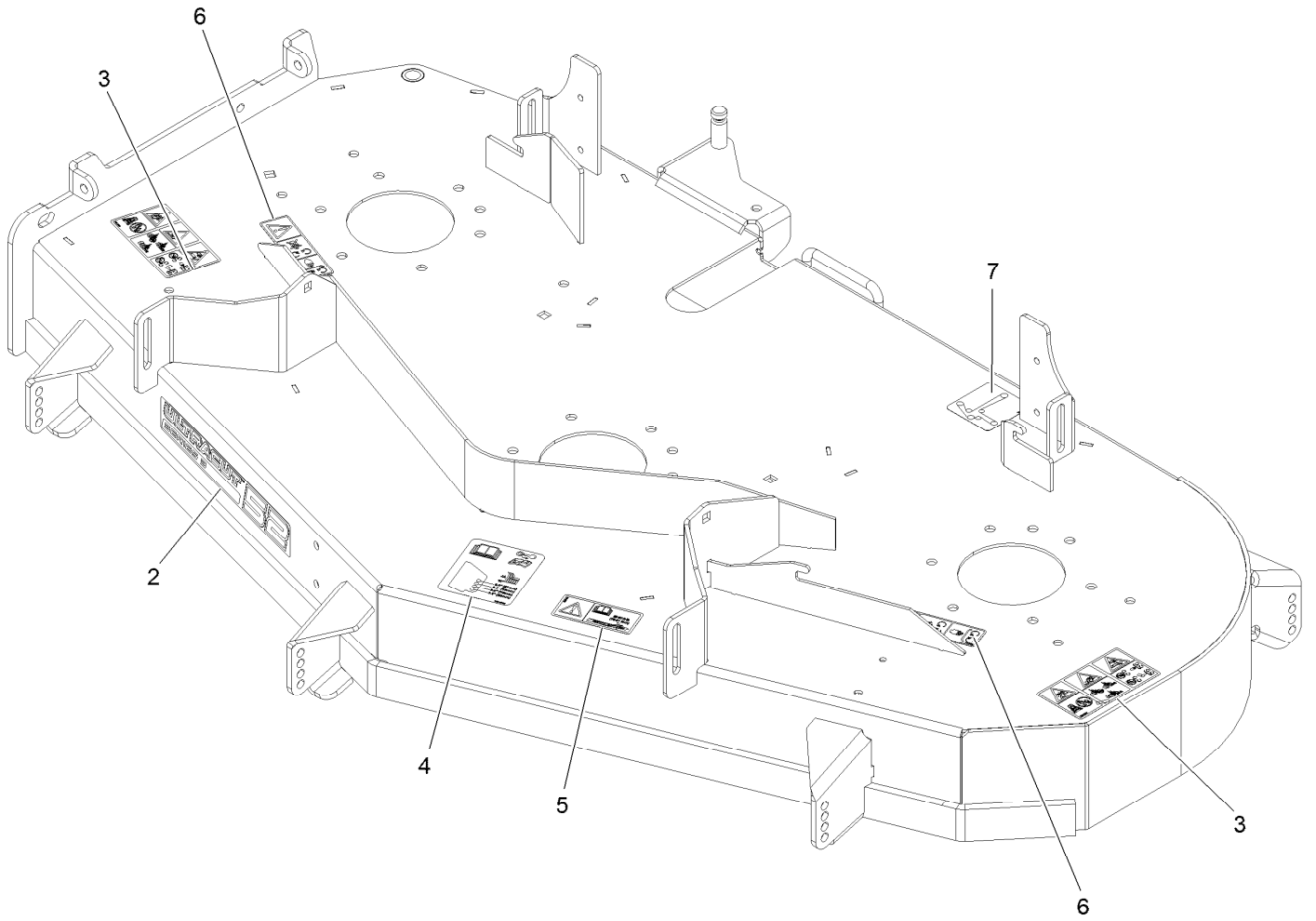



## Deck W/Decals Assembly No. 126-3578 (continued)

<i>Ref.</i>	<i>Part Number</i>	<i>Qty.</i>	<i>Description</i>
2	126-6747	1	Decal-Ultracut 52 Series 3
3	126-6464	2	Decal-Danger Thrown Objects
4	109-6036	1	Decal-Roller, Anti-Scalp

<i>Ref.</i>	<i>Part Number</i>	<i>Qty.</i>	<i>Description</i>
5	116-8283	1	Decal-Bolt Torque
6	112-9028	2	Decal-Missing, Cover
7	109-6035	1	Decal-Belt Routing

# Idler Arm W/Bearings Assembly

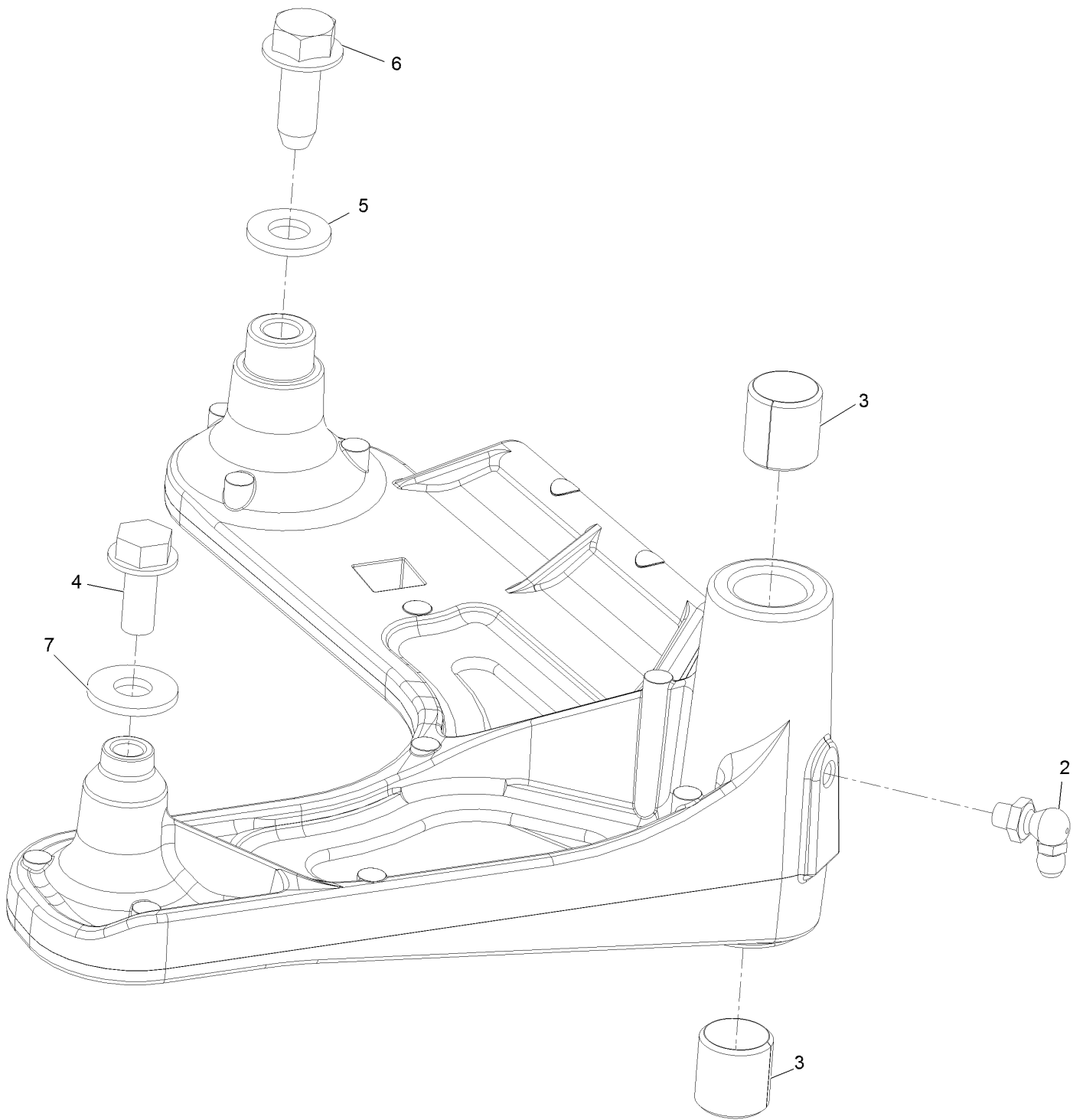

## Idler Arm W/Bearings Assembly (continued)

<i>Ref.</i>	<i>Part Number</i>	<i>Qty.</i>	<i>Description</i>	<i>Ref.</i>	<i>Part Number</i>	<i>Qty.</i>	<i>Description</i>
2	302-40	1	Zerk-90° 1/4-28	5	3256-24	1	Washer-3/8 SAE
3	1-513034	2	Sleeve-Bearing	6	126-1696	1	Screw-Forming, Thread
4	32144-11	1	Screw-HWH 5/16-18 X 3/4 Tf	7	3256-3	1	Washer-5/16 Std

# Main Frame Assembly

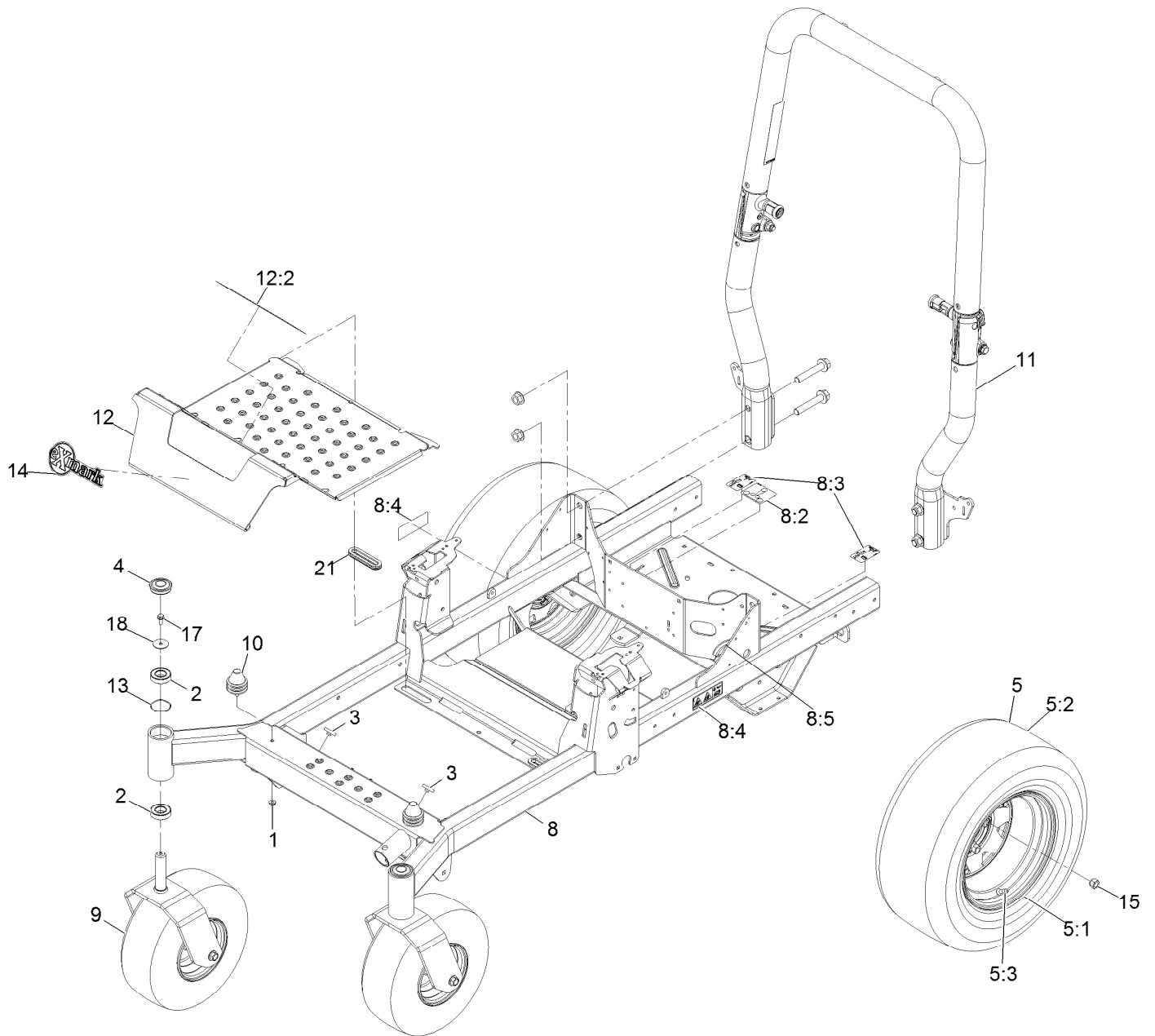

## Main Frame Assembly (continued)

<i>Ref.</i>	<i>Part Number</i>	<i>Qty.</i>	<i>Description</i>	<i>Ref.</i>	<i>Part Number</i>	<i>Qty.</i>	<i>Description</i>
1	104-8300	2	Nut-HF, NI	8:5	127-6618	1	Strip-Seal
2	109-3678	4	Bearing-Ball	9		2	ASM-Front Caster W/Fork ●
3	109-9233	2	Bumper-Push-In, Rubber	10	126-5491	2	Isolator
4	116-4348	2	Cap-Grease	11	126-9525	1	ASM-ROPS Tapered
5	116-6318	2	Wheel And Tire ASM	12	126-5872	1	Pan-Floor
5:1	116-6320	1	Wheel-12X7, 8 Spoke 4 On 4	12:2	126-8383	1	Decal-Danger
5:2	120-3271	1	Tire	13	126-5897	2	Spring
5:3	232-27	1	Stem-Valve	14	126-8819	1	Decal-Exmark Logo
8	126-4699	1	Frame ASM	15	242-50	8	Nut-Lug
8:2	109-6014	1	Decal-Routing, Belt	17	3234-5	2	Screw-HHF
8:3	116-8588	2	Decal-Release, Drive	18	3256-68	2	Washer-Flat
8:4	126-4363	2	Decal-Warning	21	126-7065	2	Grommet-Rubber

● Not serviced separately

# Caster Wheel Assembly

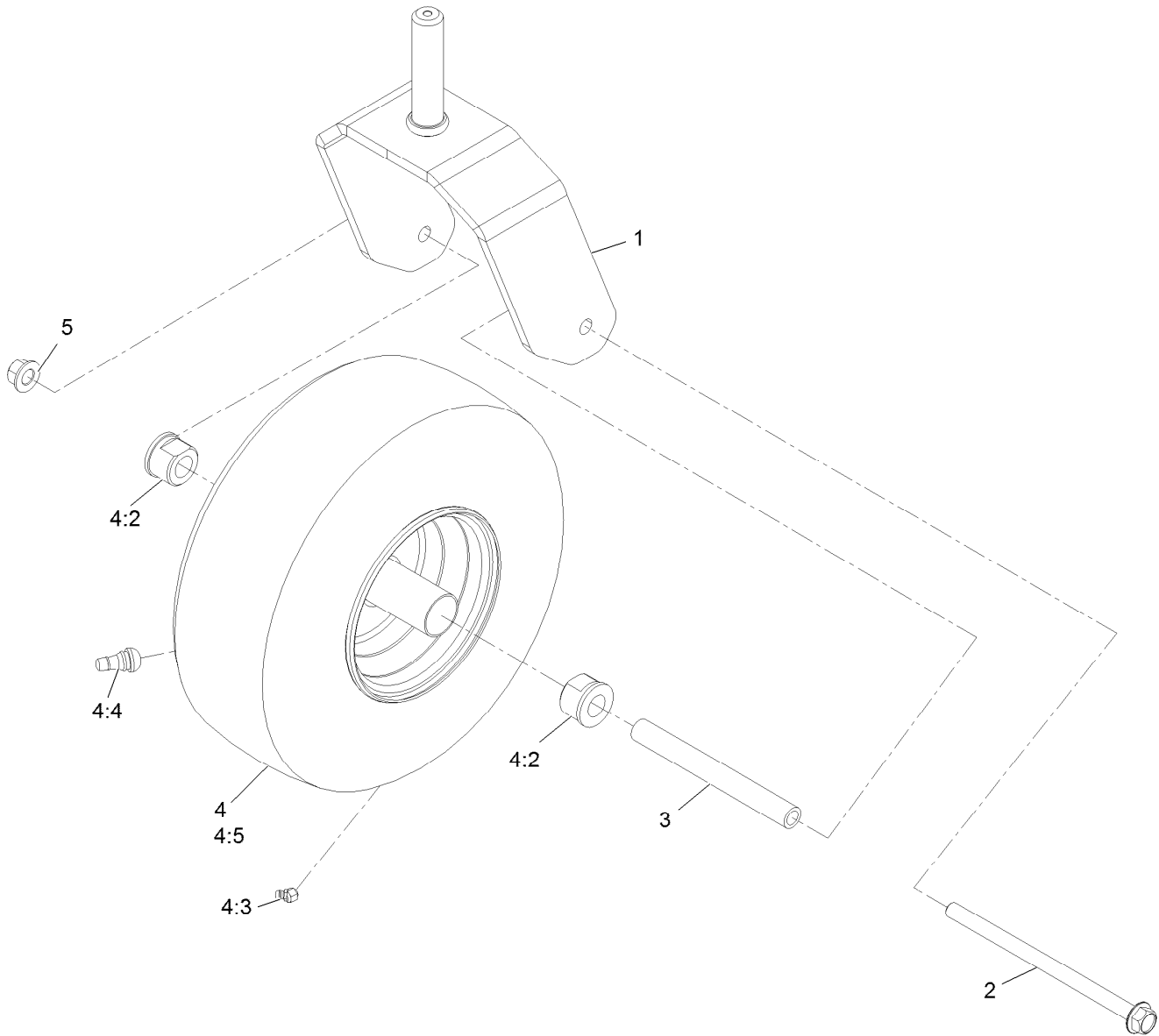

## Caster Wheel Assembly (continued)

<i>Ref.</i>	<i>Part Number</i>	<i>Qty.</i>	<i>Description</i>	<i>Ref.</i>	<i>Part Number</i>	<i>Qty.</i>	<i>Description</i>
1	126-4312-01	1	Fork-Caster	4:3	120-7125	1	Fitting-Zerk
2	126-5389	1	Screw-HHF	4:4	5108	1	Valve
3	127-0068	1	Spanner-Wheel, Caster	4:5	126-5959	1	Tire
4	126-4860	1	ASM, Tire & Wheel	5	99-5107	1	Nut-Lock 1/2-13
4:2	114-1640	2	Bushing-Flange				

# Roll-Over Protection System Assembly

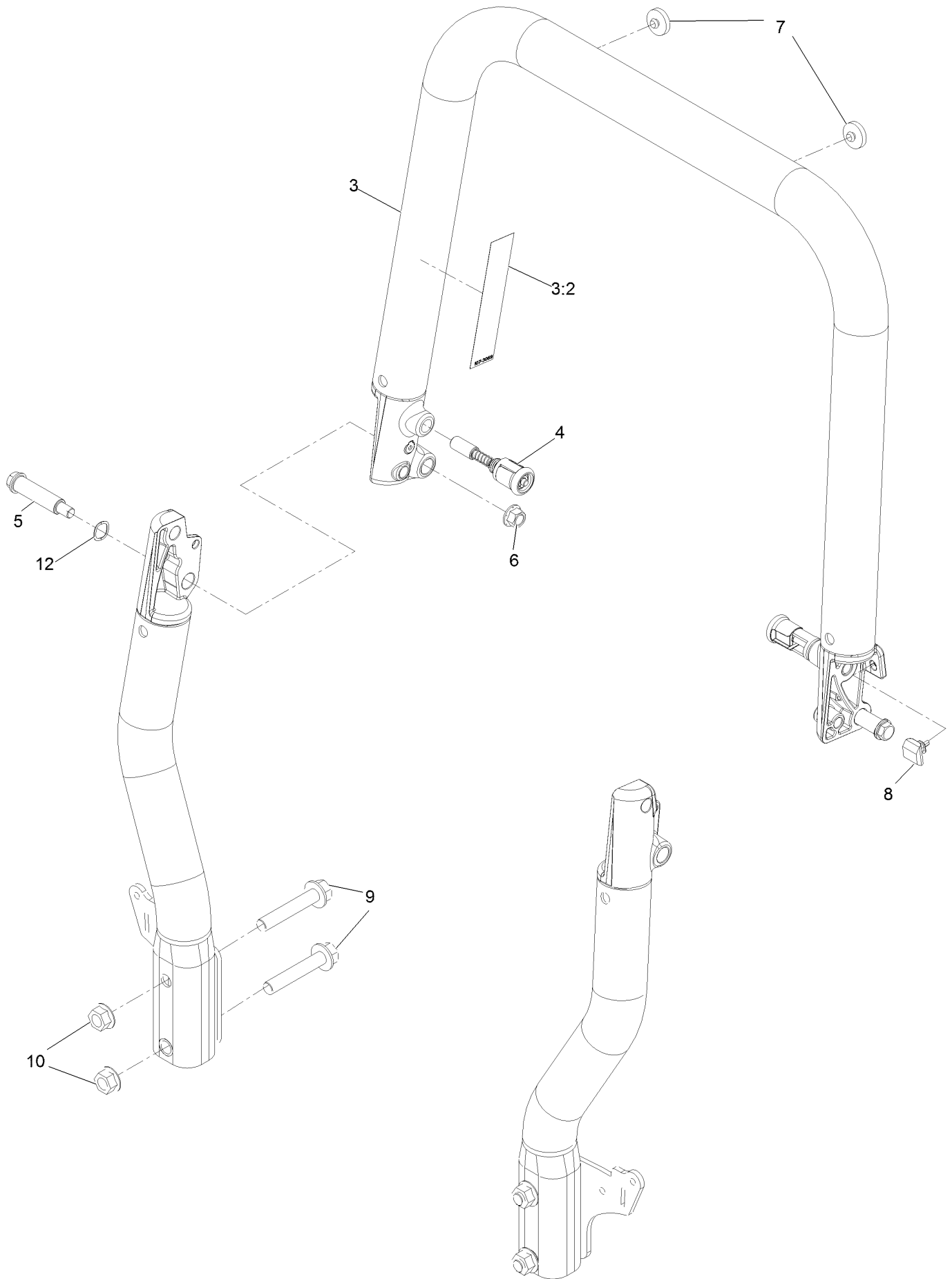



## Roll-Over Protection System Assembly (continued)

<i>Ref.</i>	<i>Part Number</i>	<i>Qty.</i>	<i>Description</i>	<i>Ref.</i>	<i>Part Number</i>	<i>Qty.</i>	<i>Description</i>
3	126-7838	1	Top Tube ASM	8	126-9966	2	Bumper-ROPS
3:2	107-3069	1	Decal-Warning	9	126-9488	4	Screw-HHF 5/8-18 X 3 1/2 Gr 8
4	116-0104	2	Pin-Spring	10	32128-50	4	Nut-Whizlock 5/8-11
5	126-9209	2	Bolt-Shoulder	12	119-4164	2	Washer-Wave
6	99-5107	2	Nut-Lock 1/2-13				
7	109-9233	2	Bumper-Push-In, Rubber				

# Deck Lift Assembly

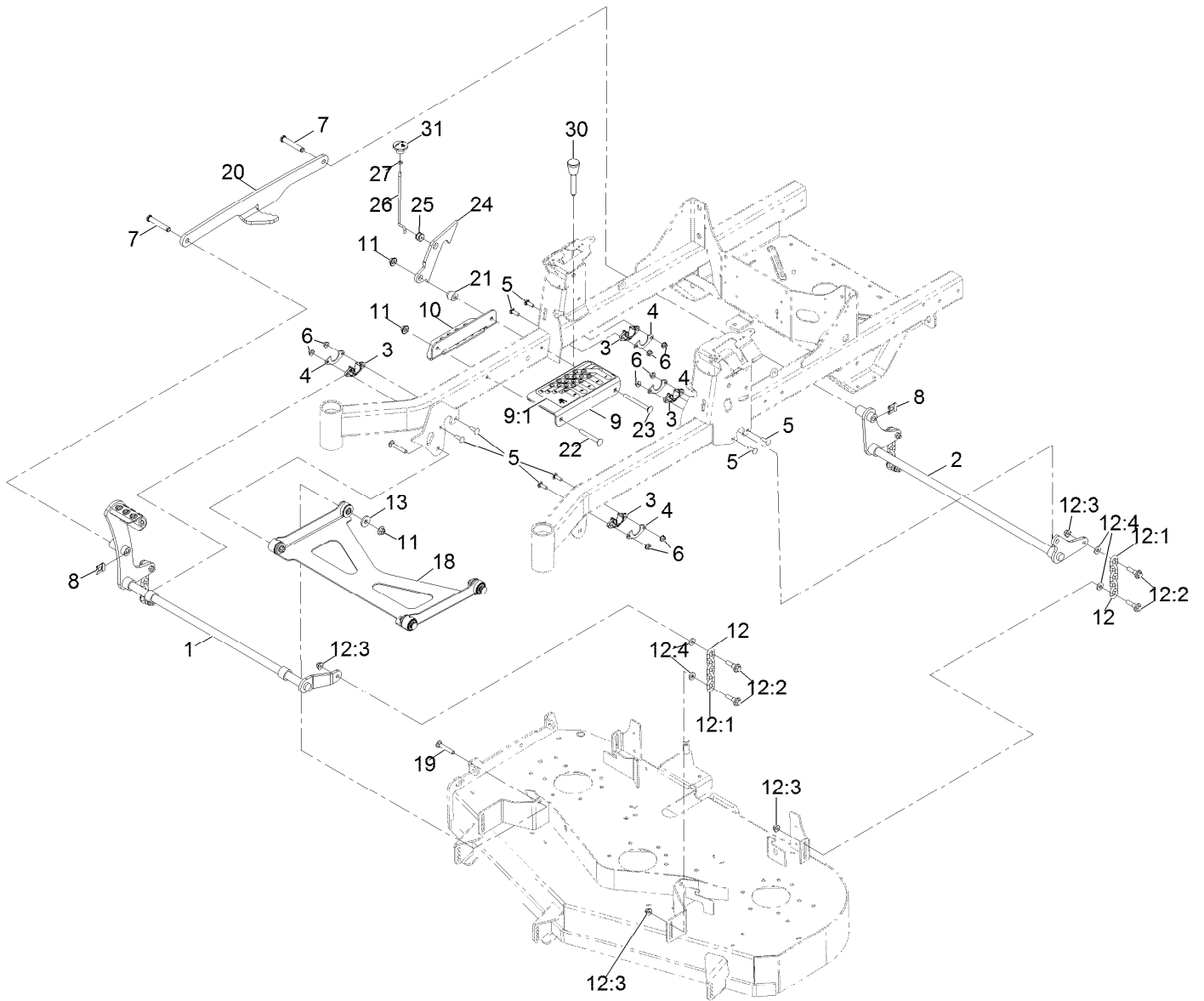

## Deck Lift Assembly (continued)

<i>Ref.</i>	<i>Part Number</i>	<i>Qty.</i>	<i>Description</i>	<i>Ref.</i>	<i>Part Number</i>	<i>Qty.</i>	<i>Description</i>
1	126-3342-03	1	Shaft-Lift, Deck	12:3	104-8301	2	Nut-HF, NI
2	126-3343-03	1	Shaft-Lift, Deck (Rear)	12:4	43-0940	2	Spacer
3	115-5065	4	Bushing-Flange	13	1-373034	2	Washer
4	116-2887	4	Gusset-Lift, Deck	18	126-8365	1	Deck Strut ASM
5	3230-22	8	Screw-CARR	19	3231-7	2	Screw-CARR
6	104-8300	8	Nut-HF, NI	20	126-4639-03	1	Link-Lift
7	126-9181	2	Pin-Clevis	21	126-5221	1	Spacer-Stepped
8	95-4064	2	Clip-Pin	22	3231-42	1	Screw-CARR
9	126-4535	1	Bracket ASM	23	3231-37	1	Screw-CARR
9:1	126-4784	1	Decal-HOC	24	126-5222	1	Plate-Lock, Transport
10	126-4640-03	1	Angle-HOC, Lower	25	126-5593	1	Grommet
11	109-6658	4	Nut-Flange, NI	26	126-5223	1	Rod-Lock, Transport
12	126-8877	4	Deck Chain ASM	27	3218-1	1	Nut-Jam
12:1	1-633447	1	Chain-Lift, Deck	30	126-5401	1	Pin-HOC
12:2	130-0742	2	Bolt-Shoulder	31	126-7019	1	Knob

# Deck Strut Assembly

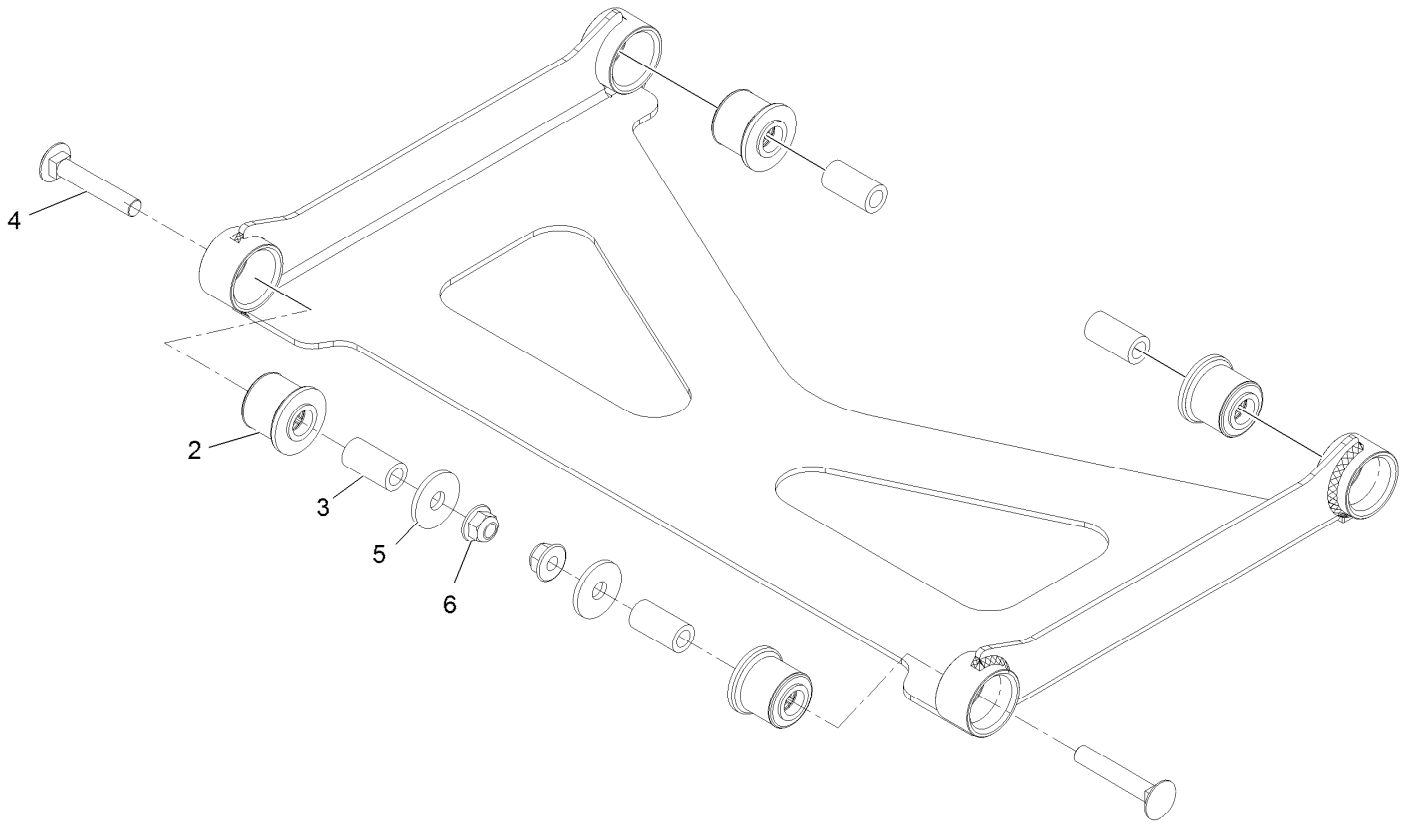

## Deck Strut Assembly (continued)

<i>Ref.</i>	<i>Part Number</i>	<i>Qty.</i>	<i>Description</i>	<i>Ref.</i>	<i>Part Number</i>	<i>Qty.</i>	<i>Description</i>
2	126-8360	4	Bushing-Rubber, Suspension	4	3231-7	2	Bolt-Carriage 3/8-16 X 2 1/4
3	108-6544	4	Spacer	5	2844	2	Washer
				6	104-8301	2	Nut-Nyloc 3/8-16 Flg

# Controls Assembly

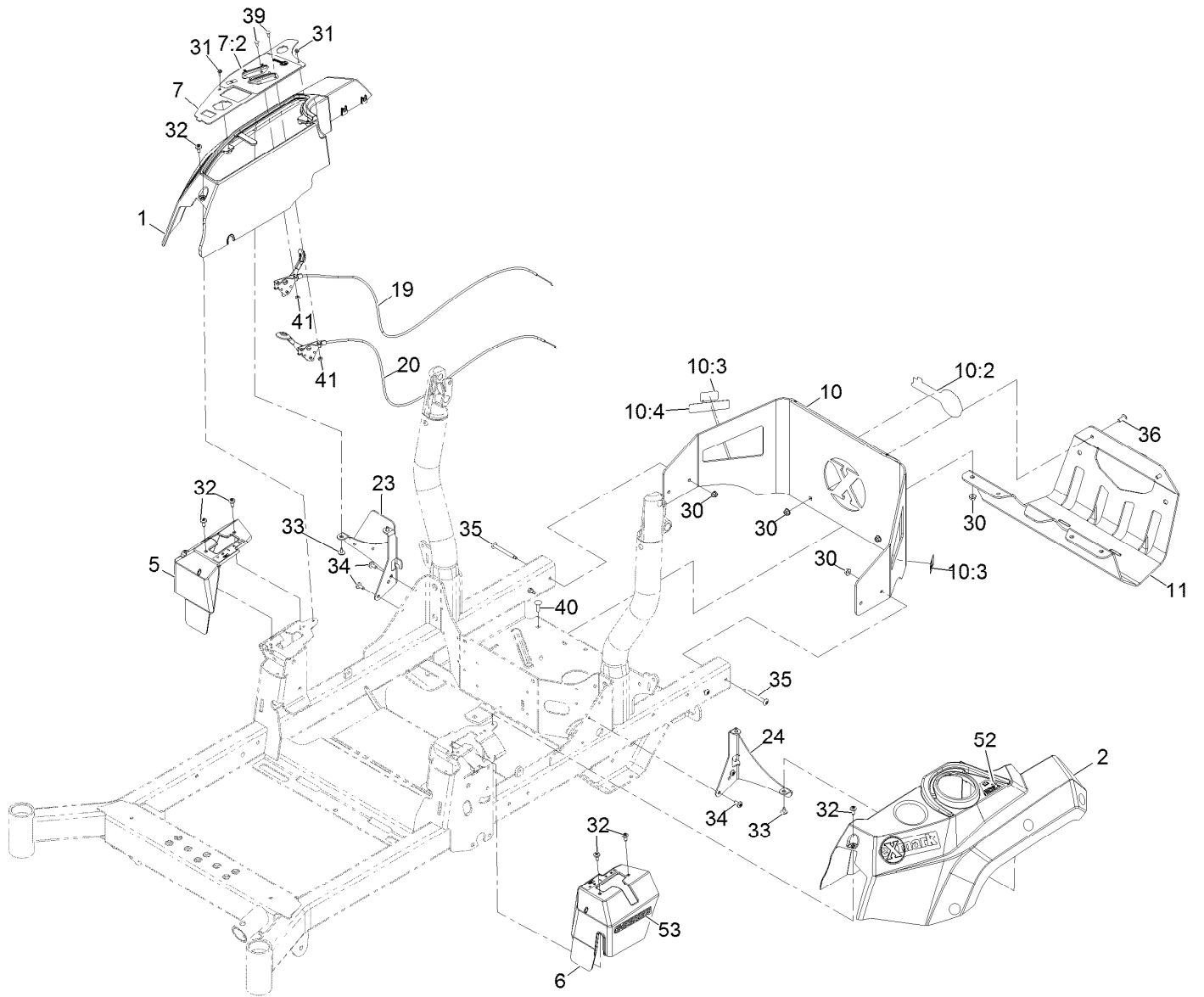

## Controls Assembly (continued)

<i>Ref.</i>	<i>Part Number</i>	<i>Qty.</i>	<i>Description</i>	<i>Ref.</i>	<i>Part Number</i>	<i>Qty.</i>	<i>Description</i>
1	126-6025	1	Console, RH	32	120-7950	6	Screw-1/4-20 X 1/2 Tf Torx Plus
2	126-6026	1	Console, LH	33	126-5544	4	Screw-HWH #10-14 X 1/2 Torx
5	126-7371	1	Cover-Motion Control, RH	34	126-6266	4	Screw-1/4-20 X .65 Torx Plus
6	126-7372	1	Cover-Motion Control, LH	35	126-6267	4	Screw-Truss HD 5/16-18 X 2 3/4 Torx Plus
7	126-7789	1	Ctrl Panel ASM W/Decal	36	126-6268	2	Screw-Truss HD 5/16-18 X 3/4 Torx Plus
7:2	126-6570	1	Decal-Control Panel	39	1-807513	4	Bolt-Carriage #10-24 X 1/2
10	126-7802	1	Rear Guard ASM	40	3230-22	2	Bolt-Carriage 5/16-18 X 1 Sp
10:2	126-6965	1	Decal-Exmark Logo	41	3296-2	4	Nut-Nyloc #10-24
10:3	106-5517	2	Decal-Warning	52	126-9939	1	Decal-Fill, Fuel
10:4	117-2718	1	Decal-Arrester, Spark	53	126-9295	2	Decal-E-Series
11	126-7664-03	1	Guard-Muffler				
19	126-6945	1	Cable-Control, Choke				
20	126-6944	1	Cable-Control, Throttle				
23	126-9945	1	Support-Console, RH				
24	126-5532-03	1	Bracket-Console, LH				
30	104-8300	8	Nut-Nyloc 5/16-18 Flg				
31	117-5036	2	Screw-HWH #10-14 X 1/2				

# Motion Control Assembly

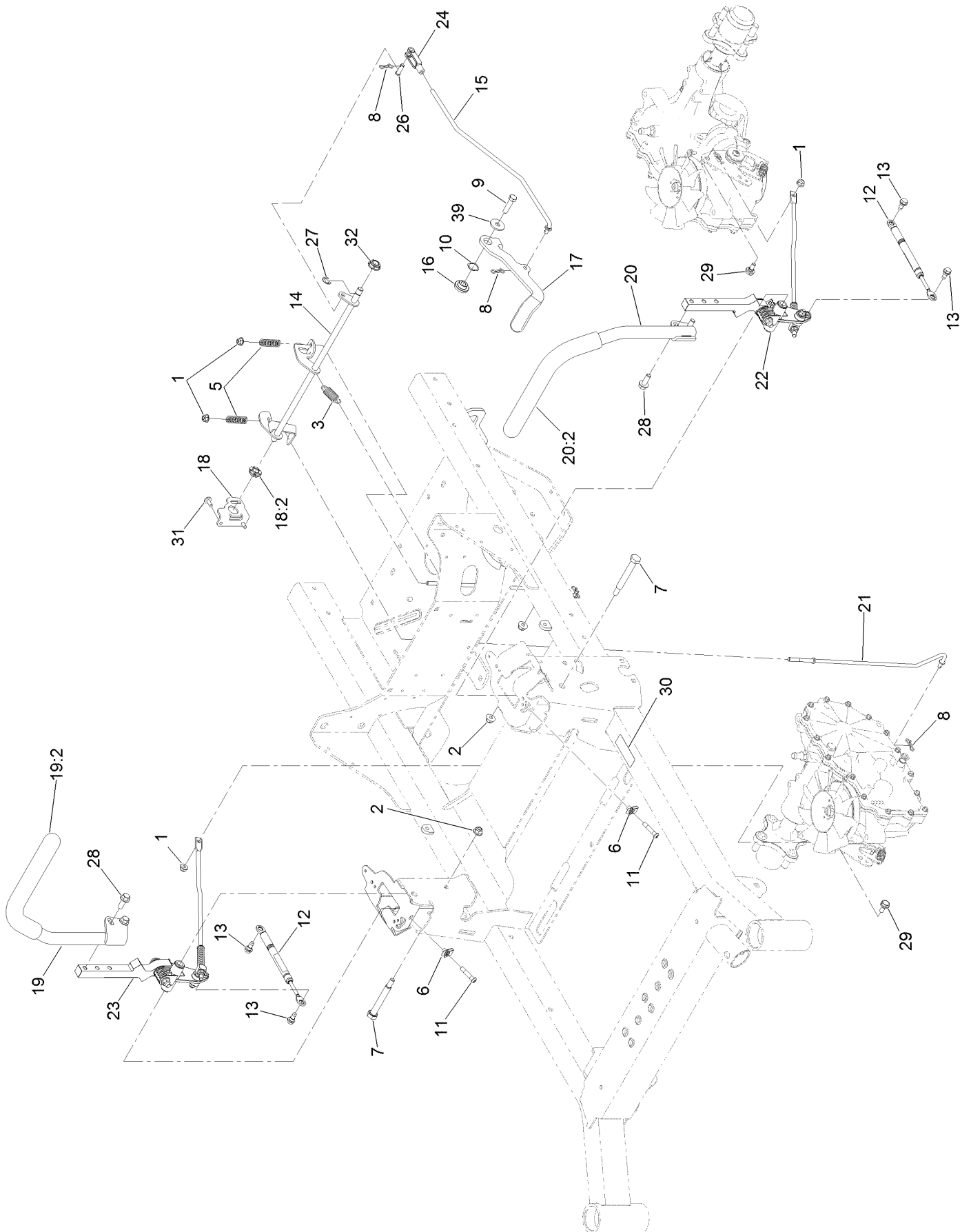



## Motion Control Assembly (continued)

<i>Ref.</i>	<i>Part Number</i>	<i>Qty.</i>	<i>Description</i>	<i>Ref.</i>	<i>Part Number</i>	<i>Qty.</i>	<i>Description</i>
1	104-8300	4	Nut-HF, NI	18:2	126-5820	1	Bearing-Spherical
2	104-8301	3	Nut-HF, NI	19	126-9191	1	RH Control Handle ASM
3	107-1045	2	Spring-Extension	19:2	126-7359	1	Grip
5	109-7694	2	Spring-Compression	20	126-9192	1	LH Control Handle ASM
6	112-3306	2	Nut	20:2	126-7359	1	Grip
7	115-5099	2	Bolt-Pivot	21	126-7217	2	Linkage-Brake, Lower
8	119-1415	4	Pin-Cotter, Locking	22		1	LH Motion Control ASM ●
9	323-8	1	Screw-HH	23		1	RH Motion Control ASM ●
10	119-4164	1	Washer-Wave	24	1-303105	1	Yoke-Adjustable
11	126-4299	2	Screw-HSBH	26	1-808280	1	Pin-Clevis
12	126-4322	2	Damper	27	32120-47	1	Ring-Retaining, External
13	126-4424	4	Screw-Shoulder	28	3234-42	4	Screw-HHF
14	126-5813	1	Shaft-Brake	29	37-8771	2	Bolt-Shoulder
15	126-5819	1	Linkage-Brake, Upper	30	115-9625	1	Decal-Brake, Parking
16	126-5989	1	Pivot-Flange	31	126-6266	2	Screw-Torx
17	126-9490	1	Lever-Brake (With Grip)	32	126-5820	1	Bearing-Spherical
18	126-6456	1	Bracket-Brake	39	2844	1	Washer

● Not serviced separately

# LH Motion Control Assembly

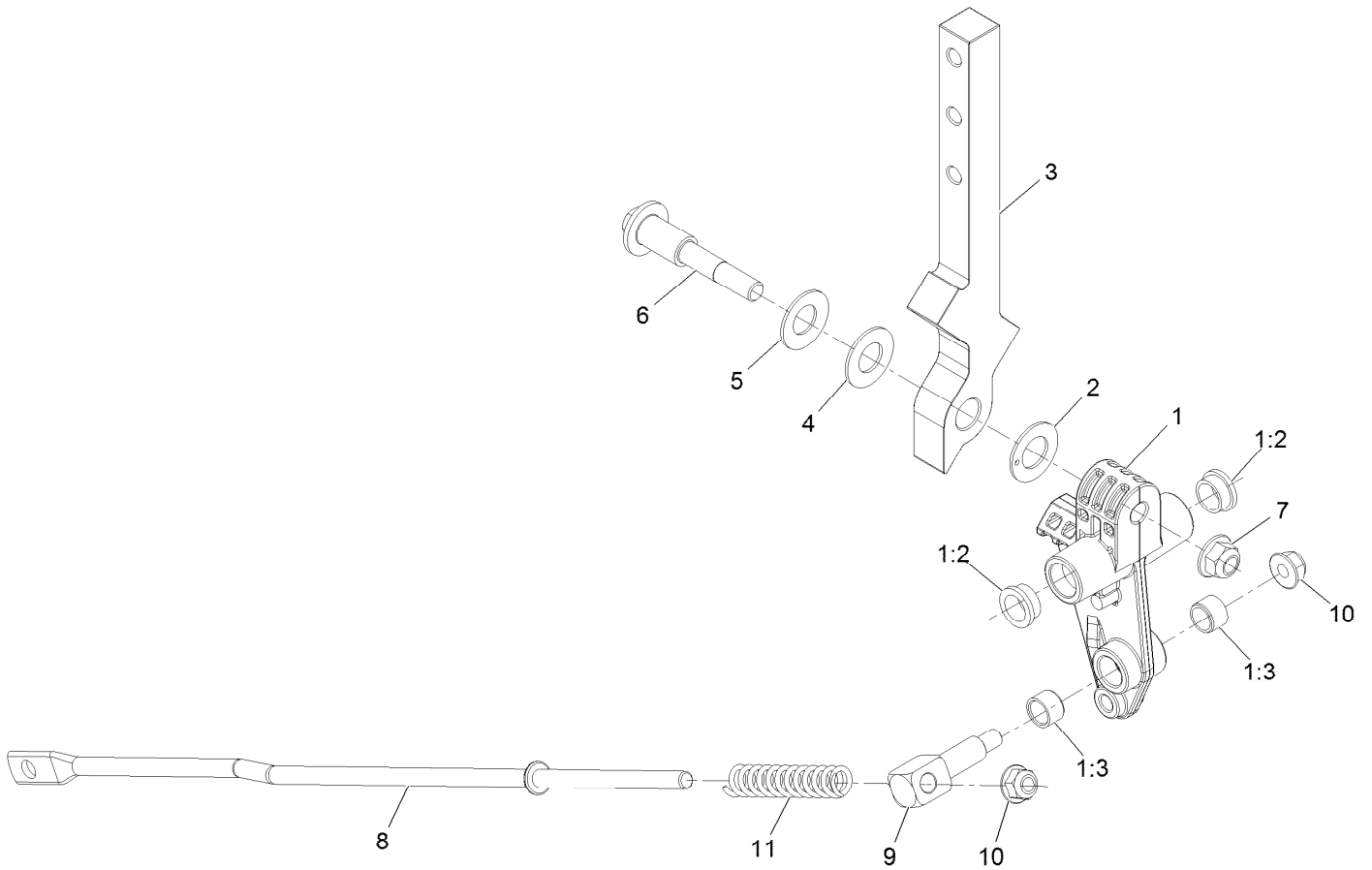

## LH Motion Control Assembly (continued)

<i>Ref.</i>	<i>Part Number</i>	<i>Qty.</i>	<i>Description</i>	<i>Ref.</i>	<i>Part Number</i>	<i>Qty.</i>	<i>Description</i>
1	126-3773	1	Control Arm ASM	6	117-1198	1	Bolt-Pivot
1:2	126-8909	2	Bushing	7	104-8301	1	Nut-Nyloc 3/8-16 Flg
1:3	1-413152	2	Bushing-Sleeve	8	126-5435	1	Link-Control
2	126-7296	1	Washer-Friction	9	126-5434	1	Swivel
3	126-8182	1	Arm-Control	10	104-8300	2	Nut-Nyloc 5/16-18 Flg
4	117-1240	1	Washer	11	126-8195	1	Spring-Return, Neutral
5	119-8925	1	Washer-Belleville				

# RH Motion Control Assembly

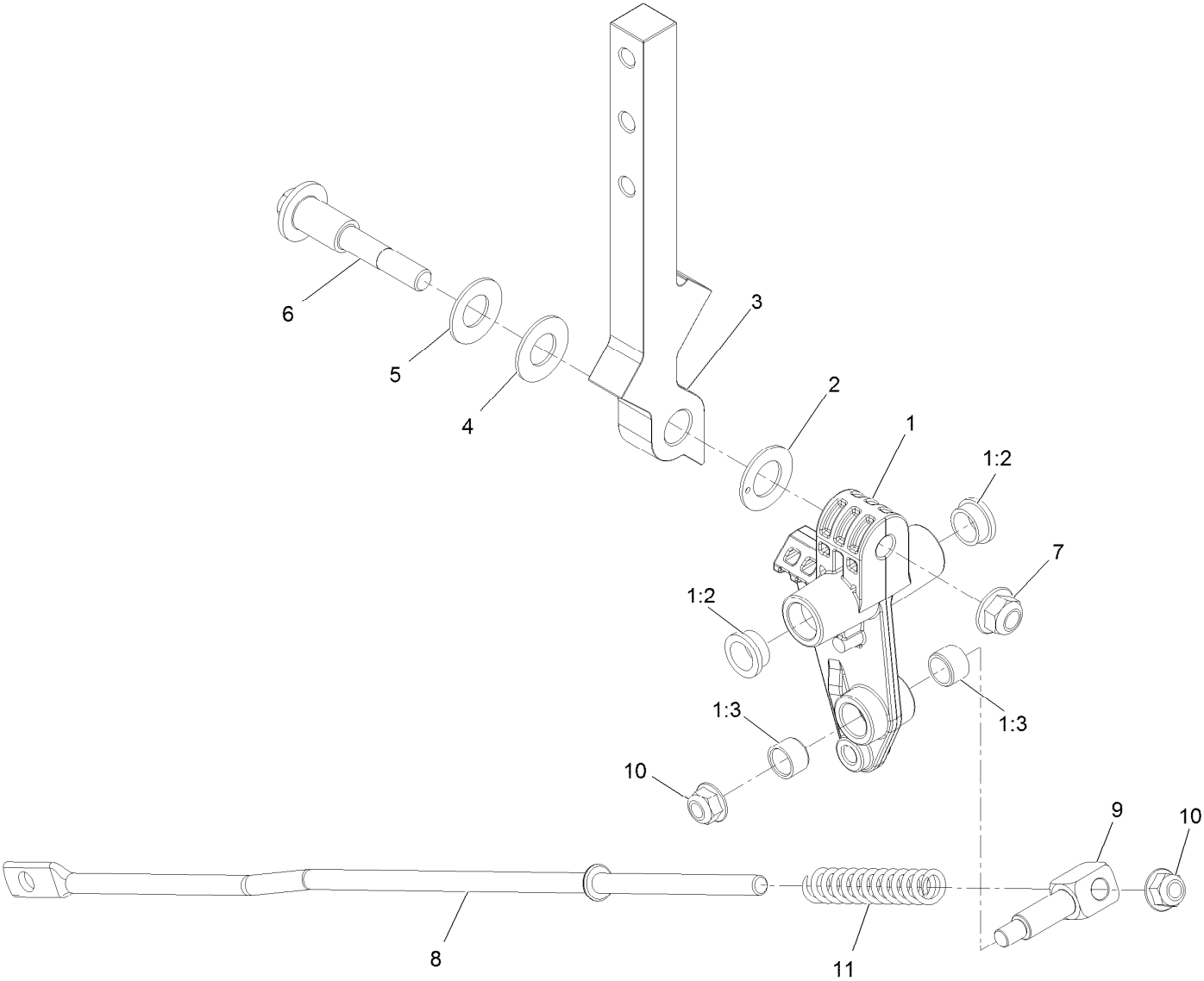

## RH Motion Control Assembly (continued)

<i>Ref.</i>	<i>Part Number</i>	<i>Qty.</i>	<i>Description</i>	<i>Ref.</i>	<i>Part Number</i>	<i>Qty.</i>	<i>Description</i>
1	126-3773	1	Control Arm ASM	6	117-1198	1	Bolt-Pivot
1:2	126-8909	2	Bushing	7	104-8301	1	Nut-Nyloc 3/8-16 Flg
1:3	1-413152	2	Bushing-Sleeve	8	126-5435	1	Link-Control
2	126-7296	1	Washer-Friction	9	126-5434	1	Swivel
3	126-8182	1	Arm-Control	10	104-8300	2	Nut-Nyloc 5/16-18 Flg
4	117-1240	1	Washer	11	126-8195	1	Spring-Return, Neutral
5	119-8925	1	Washer-Belleville				

# Fuel Assembly

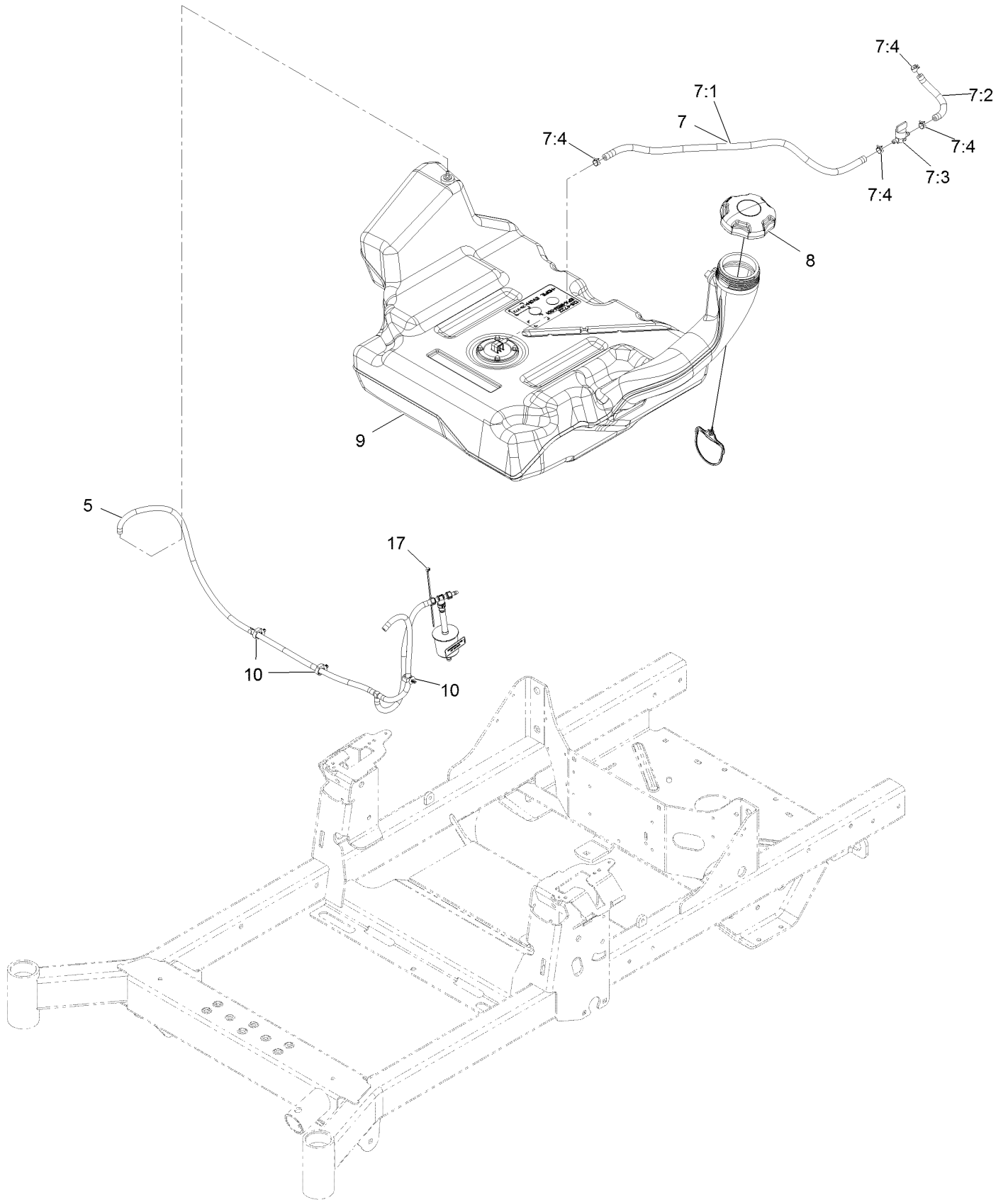

## Fuel Assembly (continued)

<i>Ref.</i>	<i>Part Number</i>	<i>Qty.</i>	<i>Description</i>	<i>Ref.</i>	<i>Part Number</i>	<i>Qty.</i>	<i>Description</i>
5	126-8738	1	Vent Hose ASM	7:4	2412-98	4	Clamp-Hose
7	126-8740	1	Fuel Hose ASM	8	126-4723	1	Cap-Fuel
7:1	109-0302	1	Hose-Fuel Line 24"	9	126-4724	1	Tank-Fuel
7:2	109-0678	1	Hose-Fuel	10	126-5523	3	Clip
7:3	1-603770	1	Valve-Fuel	17	1-303287	1	Tie-Cable 5 1/2 (Small)

# Fuel Tank Assembly (cont.)

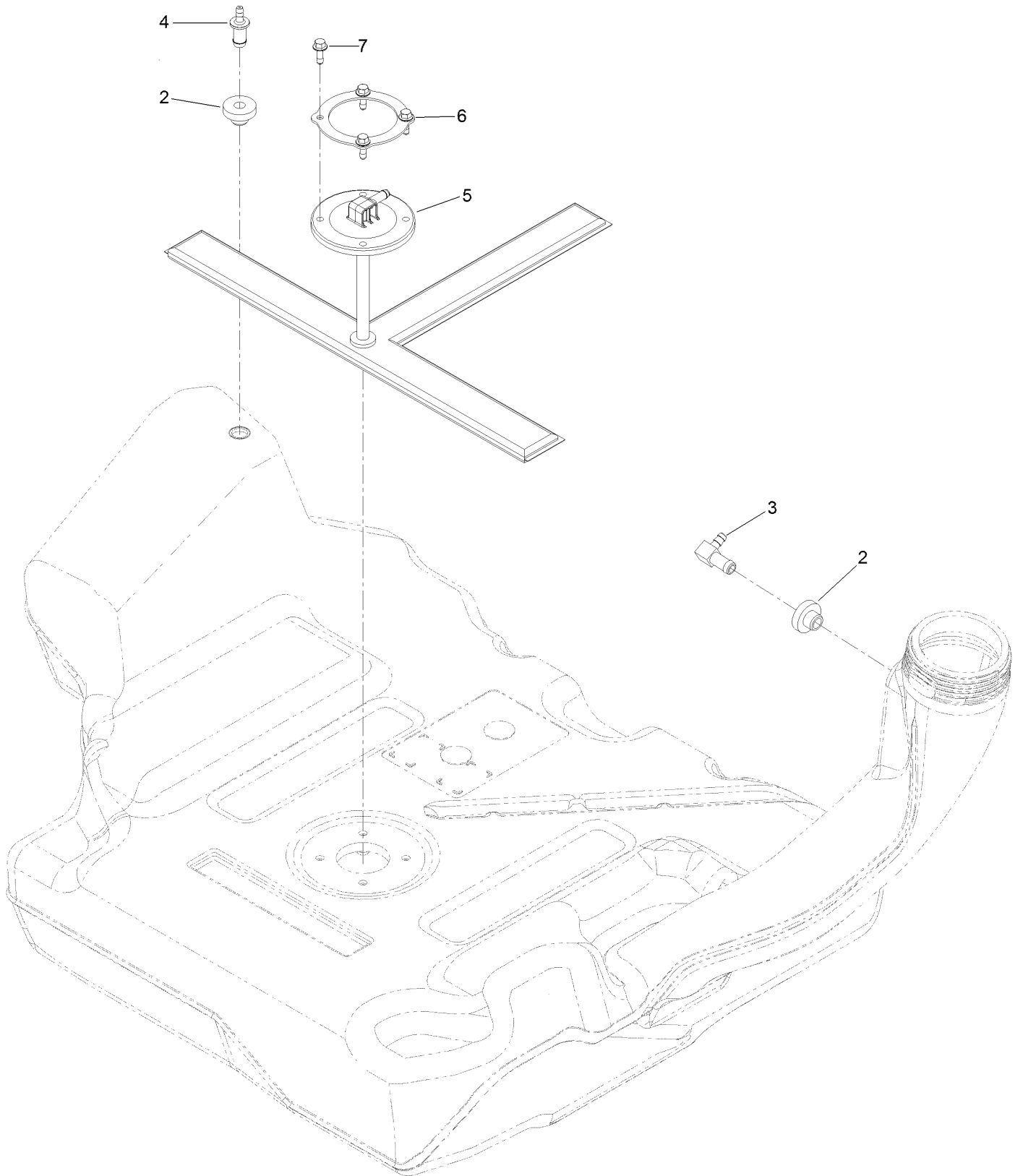



## Fuel Tank Assembly (cont.) (continued)

<i>Ref.</i>	<i>Part Number</i>	<i>Qty.</i>	<i>Description</i>	<i>Ref.</i>	<i>Part Number</i>	<i>Qty.</i>	<i>Description</i>
2	46-6560	2	Bushing	5	126-5528	1	Pickup-Fuel
3	126-9057	1	Fitting-90 DEG	6	126-5527	1	Ring-Retainer
4	116-4630	1	Fitting-Orifice, Straight	7	126-5525	4	Bolt

# Seat Assembly

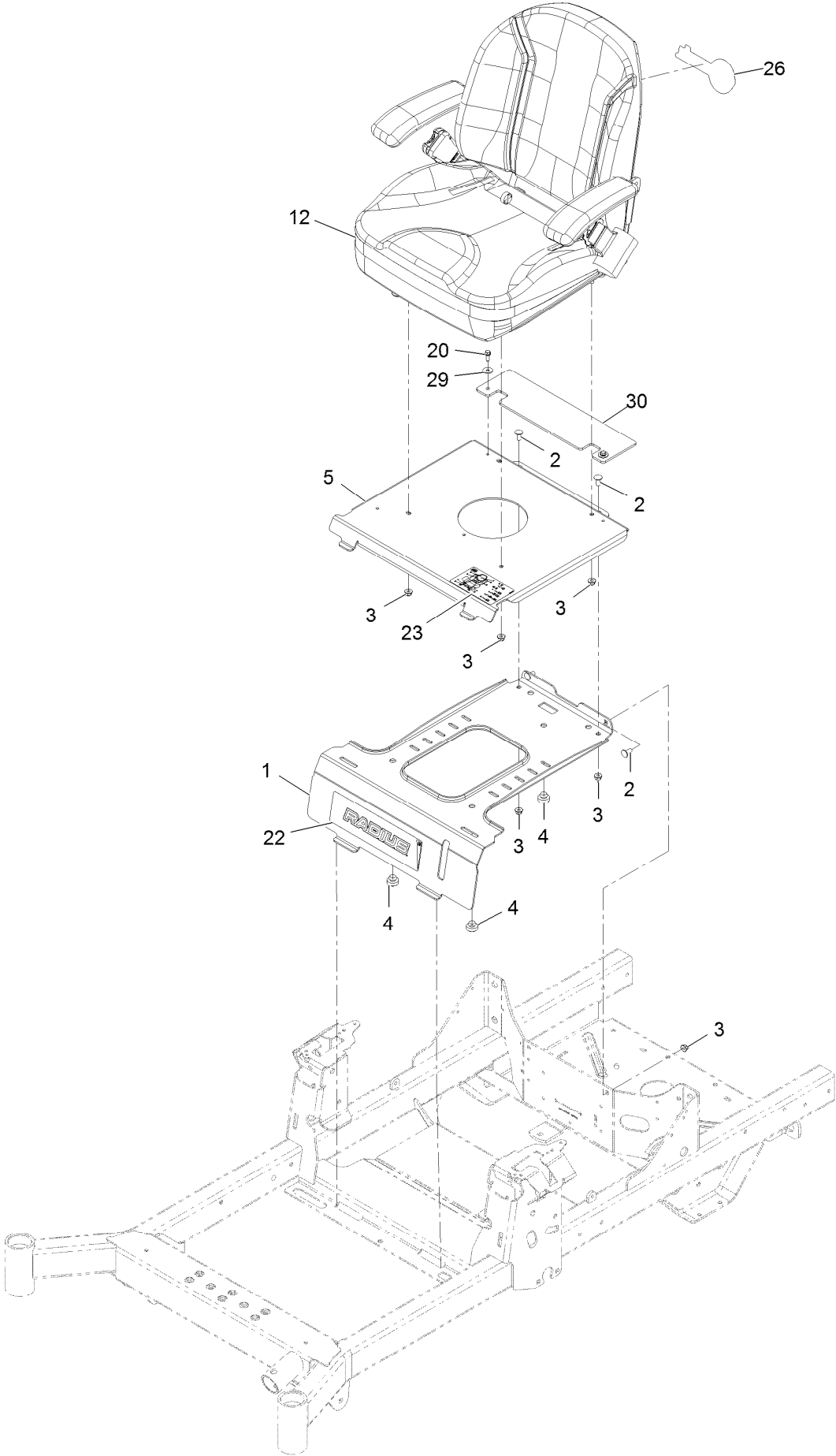

## Seat Assembly (continued)

<i>Ref.</i>	<i>Part Number</i>	<i>Qty.</i>	<i>Description</i>	<i>Ref.</i>	<i>Part Number</i>	<i>Qty.</i>	<i>Description</i>
1	126-4082-03	1	Plate-Retainer, Tank	20	32144-44	2	Screw-HWH 1/4-20 X 3/4
2	3230-23	4	Bolt-Carriage 5/16-18 X 3/4 Short Neck	22	126-9082	1	Decal-Radius Logo
3	104-8300	8	Nut-Nyloc 5/16-18 Flg	23	126-8151	1	Decal-Aid, Service
4	104-1412	3	Bumper-Rubber	26	126-6965	1	Decal-Exmark Logo
5	126-5189-03	1	Plate-Seat, Fixed	29	3256-67	2	Washer-Flat
12	126-8290	1	ASM-Seat Exmark	30	135-0104	1	Guard, Rubber

# Seat Assembly (cont)

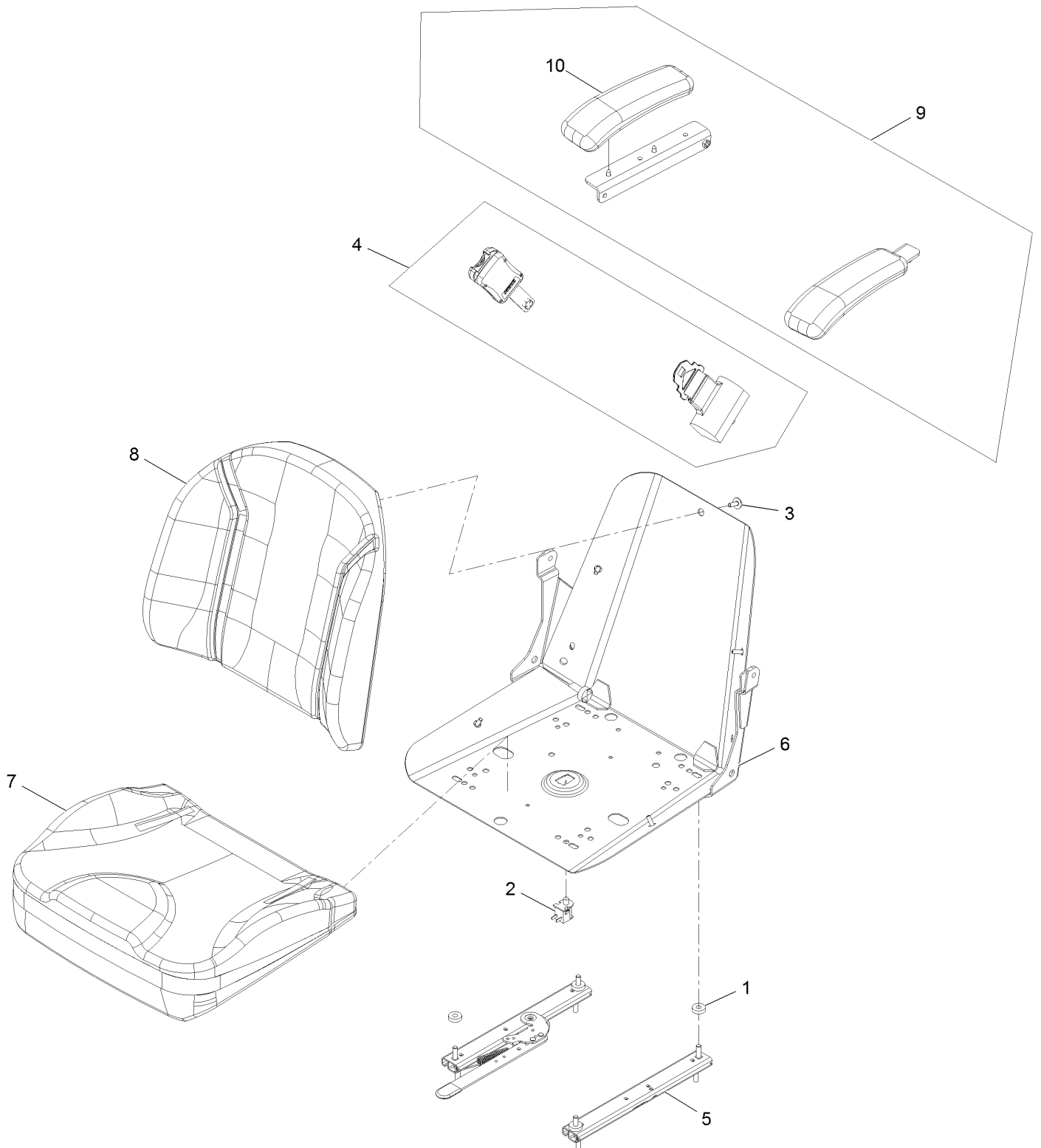

## Seat Assembly (cont) (continued)

<i>Ref.</i>	<i>Part Number</i>	<i>Qty.</i>	<i>Description</i>	<i>Ref.</i>	<i>Part Number</i>	<i>Qty.</i>	<i>Description</i>
1	26-4840	4	Spacer-Pin, Mounting	6	126-5664	1	Frame-Seat Svc
2	82-2190	1	Switch	7	126-5900	1	Cover-Seat Bottom Svc
3	103-8383	5	Screw-HWH 1/4-20 X 3/4 Taptite	8	131-4150	1	Cushion-Seat, Back
4	126-7355	1	Kit-Seat Belt	9	131-4155	1	Armrest Kit
5	126-4499	1	ASM-Seat Track Svc	10	110-4163	1	Cushion-Rest, Arm

# Fuel System Assembly

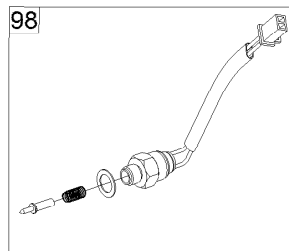
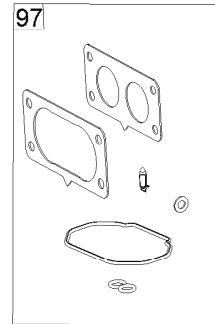
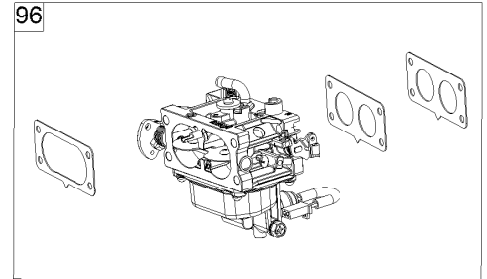
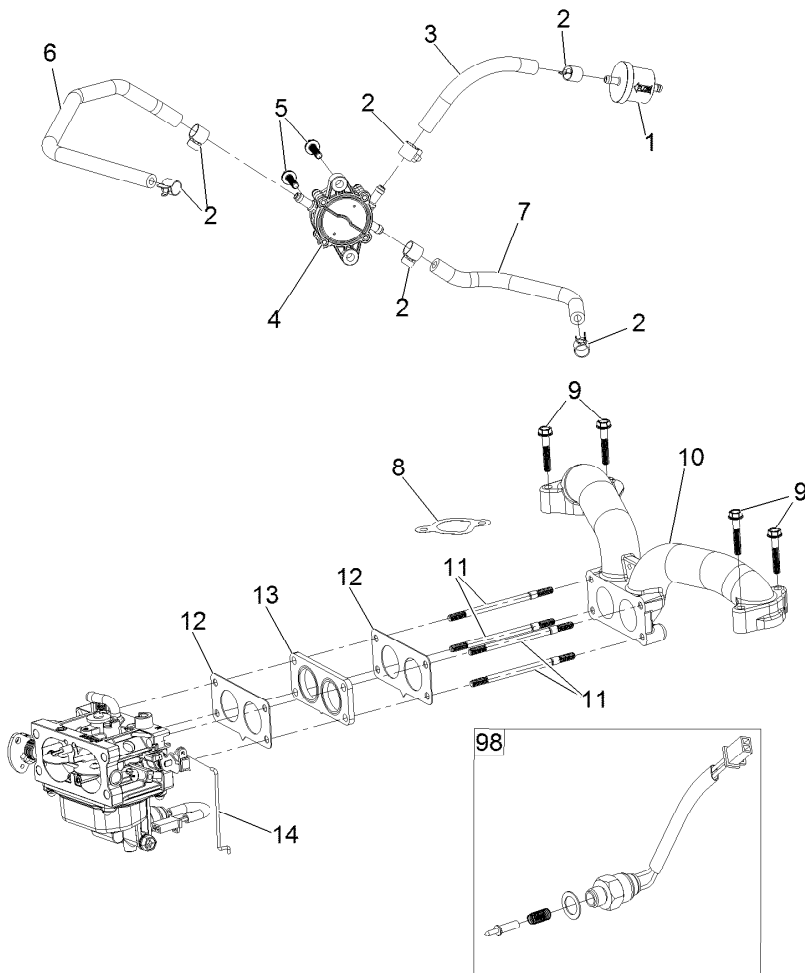

## Fuel System Assembly (continued)

<i>Ref.</i>	<i>Part Number</i>	<i>Qty.</i>	<i>Description</i>	<i>Ref.</i>	<i>Part Number</i>	<i>Qty.</i>	<i>Description</i>
1	133-1563	1	Filter-Fuel	10	127-9244	1	Manifold-Intake
2	120-4251	6	Clamp-Fuel Line	11	127-9245	4	Stud
3	120-4371	1	Line-Fuel	12	127-9246	2	Gasket-Carburetor
4	127-9206	1	Pump-Fuel	13	127-9247	1	Insulator-Carburetor
5	120-4225	2	Screw-HHF	14	127-9248	1	Linkage-Throttle
6	127-9205	1	Hose-Fuel	96	133-9808	1	Carburetor Replacement Kit
7	127-9207	1	Hose-Fuel	97	127-9290	1	Carburetor Repair Kit
8	127-9230	2	Gasket-Intake	98	127-9292	1	Solenoid Kit
9	120-4284	4	Screw-HHF	99	133-9833	1	High Altitude Kit ●

● Not illustrated

# Carburetor Assembly

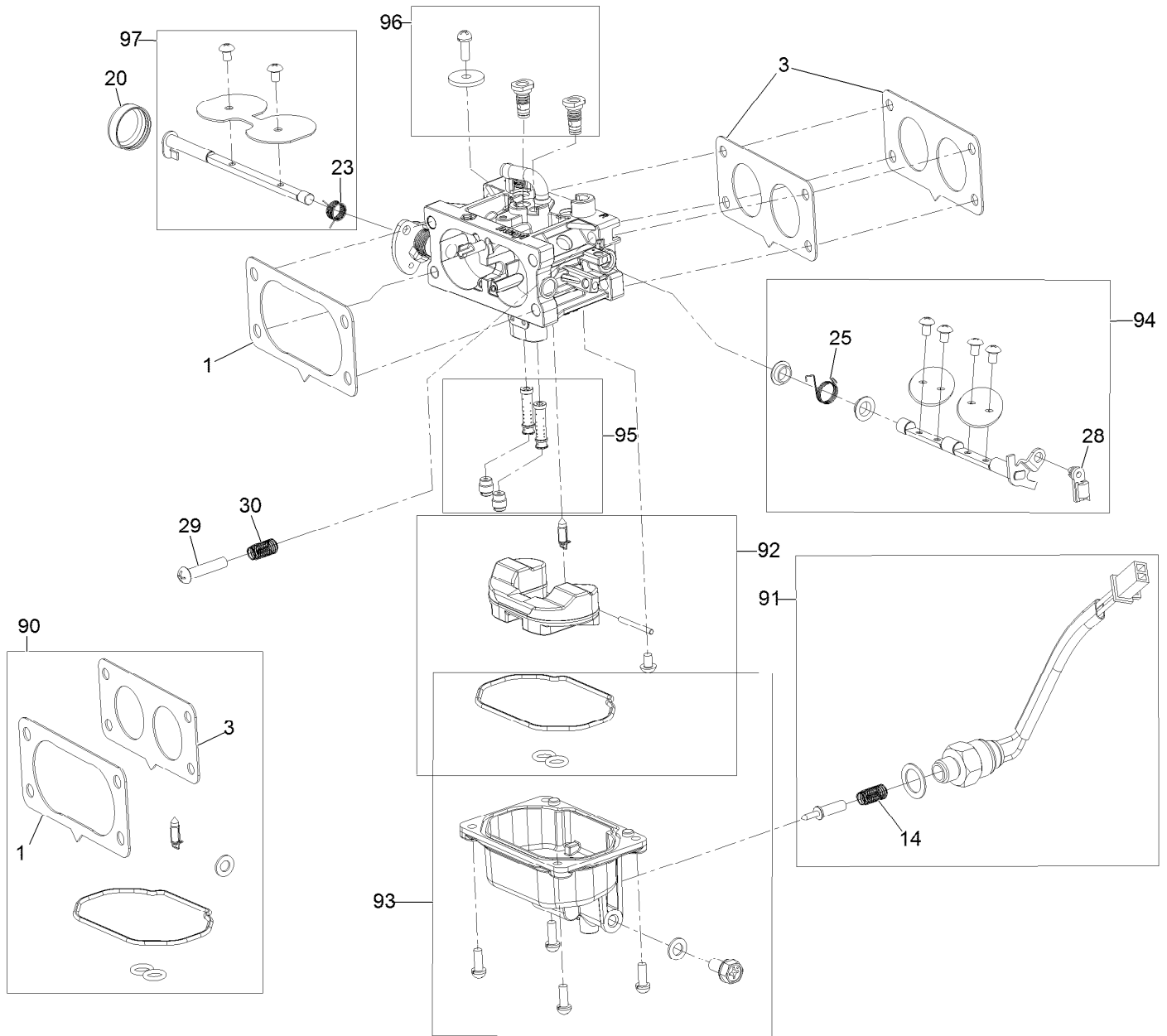



## Carburetor Assembly (continued)

<i>Ref.</i>	<i>Part Number</i>	<i>Qty.</i>	<i>Description</i>	<i>Ref.</i>	<i>Part Number</i>	<i>Qty.</i>	<i>Description</i>
1	127-9251	1	Gasket-Carburetor	90	127-9290	1	Carburetor Repair Kit
3	127-9246	2	Gasket-Carburetor	91	127-9292	1	Solenoid Kit
14	127-9319	1	Spring	92	127-9340	1	Float Kit
20	127-9325	1	Cover-Shaft, Choke	93	127-9341	1	Bowl Kit
23	127-9328	1	Spring	94	133-9817	1	Throttle Shaft Kit
25	127-9330	1	Spring	95	133-9818	1	Nozzle And Jet Kit
28	127-9333	1	Clamp-Lock	96	133-9812	1	Air Jet Kit
29	127-9334	1	Screw-PPH	97	127-9345	1	Choke Shaft Kit
30	127-9335	1	Spring				

# Engine Assembly

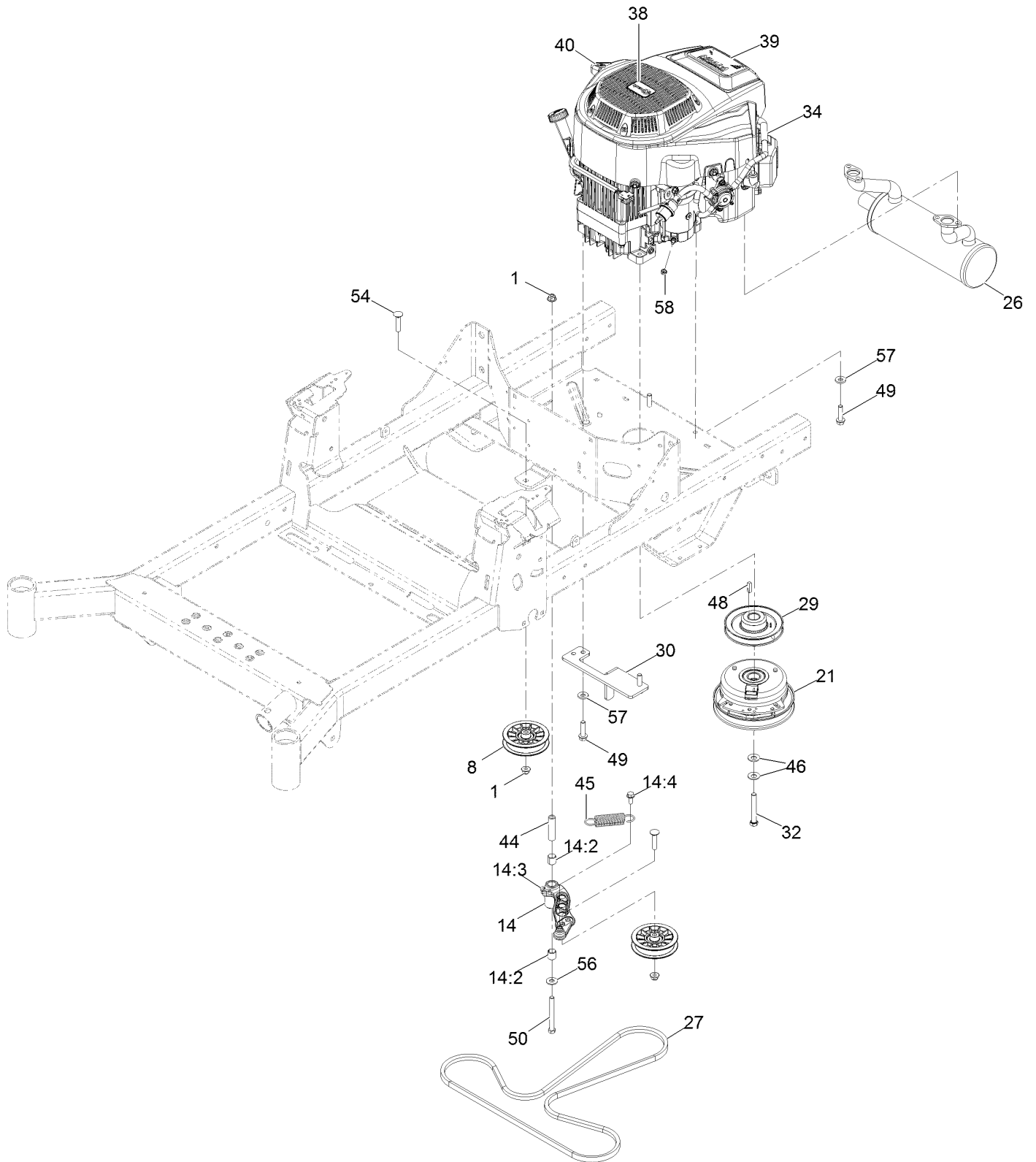

## Engine Assembly (continued)

<i>Ref.</i>	<i>Part Number</i>	<i>Qty.</i>	<i>Description</i>	<i>Ref.</i>	<i>Part Number</i>	<i>Qty.</i>	<i>Description</i>
1	104-8301	3	Nut-Nyloc 3/8-16 Flg	38	131-1078	1	Decal
8	116-2456	2	Pulley-Flat	39	126-9111	1	Decal-708Cc V-Twin Engine
14	126-0973	1	Idler Arm ASM	40	131-1097	1	Decal-Drain, Oil
14:2	1-513034	2	Sleeve-Bearing	44	1-603384	1	Bushing-Pivot, Idler
14:3	302-40	1	Zerk-90° 1/4-28	45	1-603402	1	Spring-Extension
14:4	32144-11	1	Screw-HWH 5/16-18 X 3/4 Tf	46	1-603610	2	Washer-Spring Disc 7/16
21	126-4323	1	Clutch 1.00	48	1-807259	1	Key-Machine 1/4 X 1/4 X 1
26	126-5864	1	Muffler	49	32144-102	4	Screw-HWH 3/8-16 X 1 1/2 Taptite
27	126-5993	1	Belt-V	50	323-15	1	Screw-HH 3/8-16 X 3 1/2
29	135-0134	1	Sheave-Engine	54	3231-5	2	Bolt-Carriage 3/8-16 X 1 3/4
30	126-6687-03	1	Anchor-Clutch	56	3256-4	1	Washer-3/8 Std
32	126-7198	1	Screw-HH W/Loctite ●	57	98-5975	4	Washer-Spring Disc 3/8
34	127-9451	1	Engine-2P77F	58	33003-00	1	Nut-HF

● Use Pro-Lock, Nut Type (P/N 1-840022, .5ml tube) on threads.

# Air Intake and Filtration Assembly

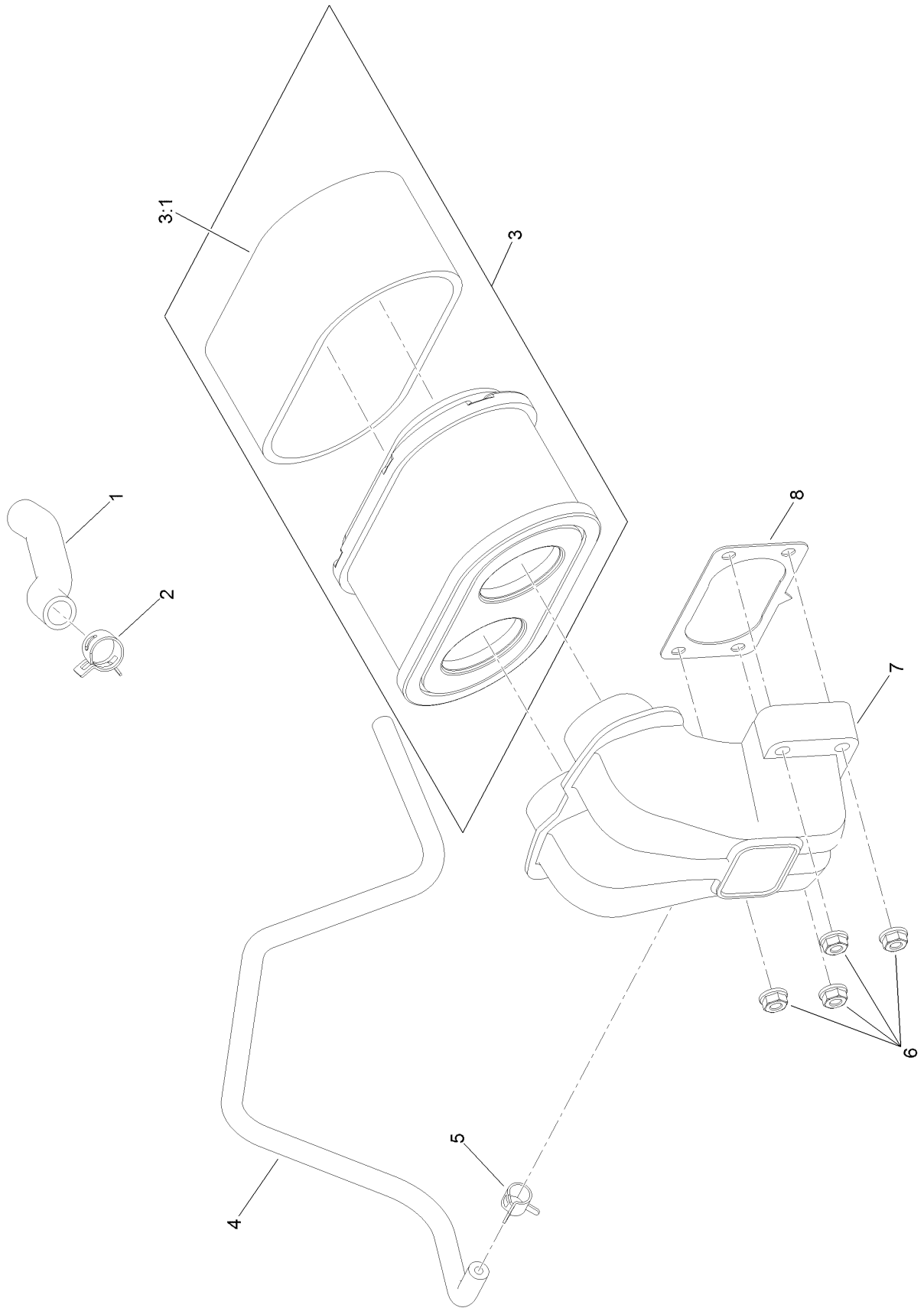

## Air Intake and Filtration Assembly (continued)

<i>Ref.</i>	<i>Part Number</i>	<i>Qty.</i>	<i>Description</i>	<i>Ref.</i>	<i>Part Number</i>	<i>Qty.</i>	<i>Description</i>
1	127-9235	1	Tube-Breather	5	127-9187	1	Clamp-Hose
2	127-9234	2	Clamp-Hose	6	120-4236	4	Nut-Flange
3	127-9252	1	Filter-Air, Complete	7	127-9047	1	Manifold-Filter, Air
3:1	127-9288	1	Filter-Pre, Foam	8	127-9251	1	Gasket-Carburetor
4	127-9253	1	Hose-Fuel				

# Ignition and Electrical Assembly

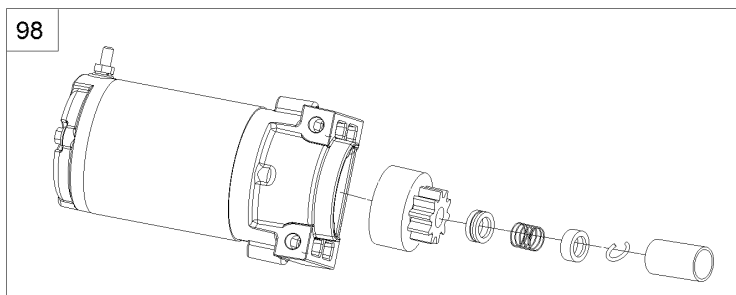
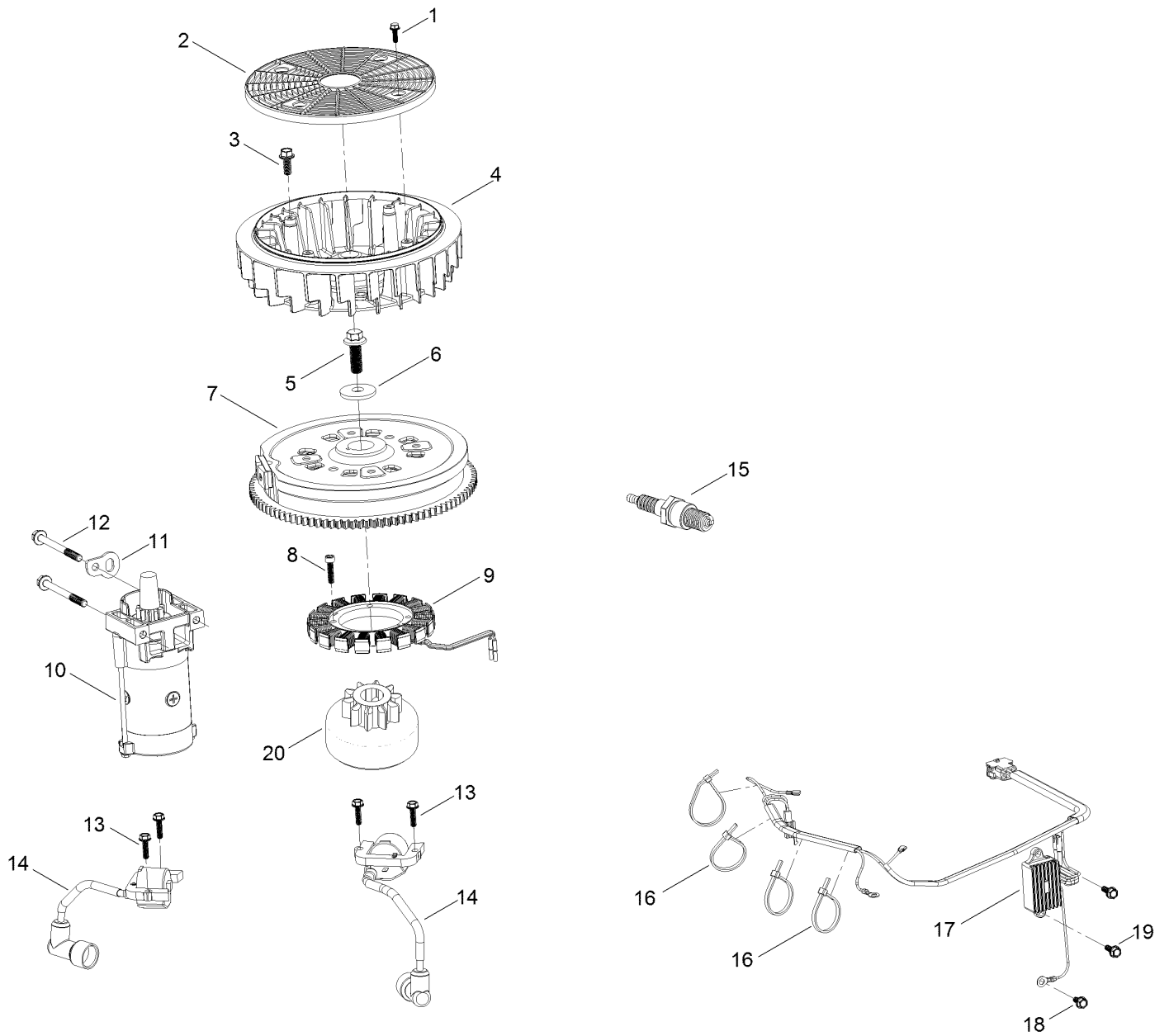

## Ignition and Electrical Assembly (continued)

<i>Ref.</i>	<i>Part Number</i>	<i>Qty.</i>	<i>Description</i>	<i>Ref.</i>	<i>Part Number</i>	<i>Qty.</i>	<i>Description</i>
1	127-9197	4	Screw-HWH	12	120-4231	2	Screw-HHF
2	127-9198	1	Screen-Rotating	13	121-0007	4	Bolt-Flange
3	127-9199	4	Screw-HWH	14	127-9216	2	Ignition Coil ASM
4	127-9200	1	Fan-Cooling	15	81-3250	2	Spark Plug
5	127-9201	1	Screw-HWH	16	127-9220	4	Tie-Zip
6	127-9202	1	Washer-Flat	17	127-9219	1	Regulator-Voltage W/Harness
7	127-9306	1	Flywheel	18	120-4216	1	Screw-HHF
8	127-9210	4	Screw-HSH	19	120-4232	2	Screw-HHF
9	127-9211	1	Alternator	20	133-1562	1	Pinion-Starter
10	133-9828	1	Motor-Starter	98	133-1566	1	Starter Repair Kit
11	127-9208	1	Bracket-Lift				

# Crankcase and Crankshaft Assembly

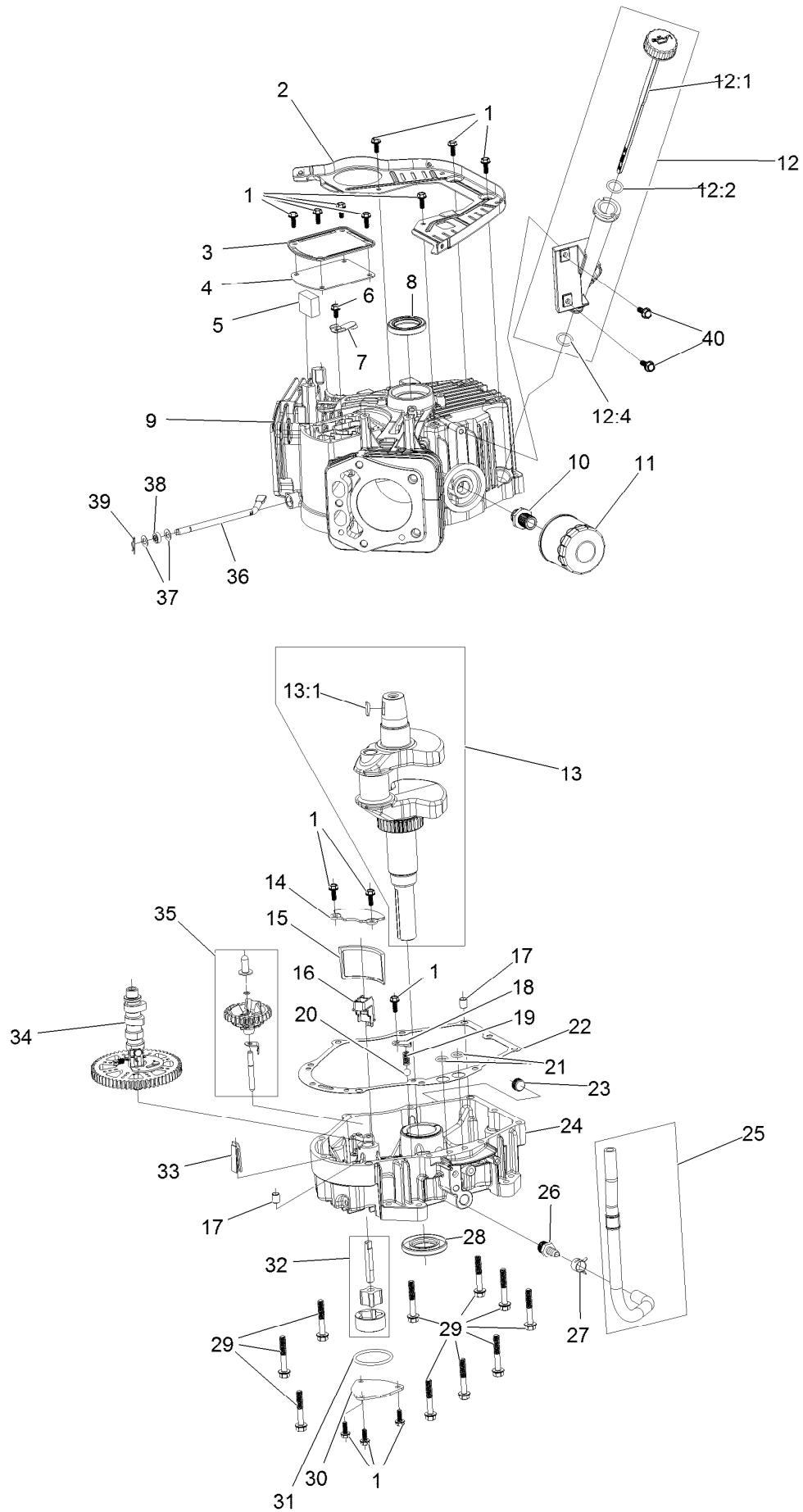



## Crankcase and Crankshaft Assembly (continued)

<i>Ref.</i>	<i>Part Number</i>	<i>Qty.</i>	<i>Description</i>	<i>Ref.</i>	<i>Part Number</i>	<i>Qty.</i>	<i>Description</i>
1	120-4232	14	Screw-HHF	19	127-9265	1	Spring
2	127-9212	1	Baffle	20	127-9266	1	Valve-Ball
3	127-9213	1	Cover-Breather	21	120-4262	2	O-Ring
4	127-9214	1	Gasket-Breather	22	127-9267	1	Gasket-Cover, Crankcase
5	127-9215	1	Filter-Breather	23	133-9805	1	Plug-Drain
6	120-4216	1	Screw-HHF	24	133-9806	1	Cover-Crankcase
7	127-9217	1	Valve-Breather	25	127-9293	1	Oil Drain Hose ASM
8	120-4267	1	Seal-Oil	26	127-9275	1	Fitting-Hose
9	127-9223	1	Crankcase	27	127-9276	1	Clamp-Hose
10	120-4346	1	Adaptor-Filter, Oil	28	127-9271	1	Seal
11	120-4276	1	Filter-Oil	29	121-0473	10	Screw-HHF
12	127-9218	1	Oil Tube ASM	30	127-9274	1	Cover-Oil Pump
12:1	127-9283	1	Dipstick	31	127-9273	1	O-Ring
12:2	127-9284	1	O-Ring	32	127-9272	1	Oil Pump ASM
12:4	127-9286	1	O-Ring	33	120-4275	1	Deflector-Oil, Rubber
13	127-9255	1	Crankshaft	34	133-1568	1	Camshaft
13:1	120-4320	1	Key-Woodruff	35	133-9807	1	Governor ASM
14	127-9261	1	Cover-Screen, Oil	36	127-9238	1	Rod-Governor
15	127-9262	1	Screen-Oil	37	120-4258	2	Washer-Plain
16	127-9263	1	Retainer-Screen	38	120-4257	1	Seal-Oil
17	120-4274	2	Pin-Dowel	39	120-4256	1	Pin-Hair
18	127-9264	1	Plate-Retainer	40	120-4232	2	Screw-HHF

# Governor Control Assembly

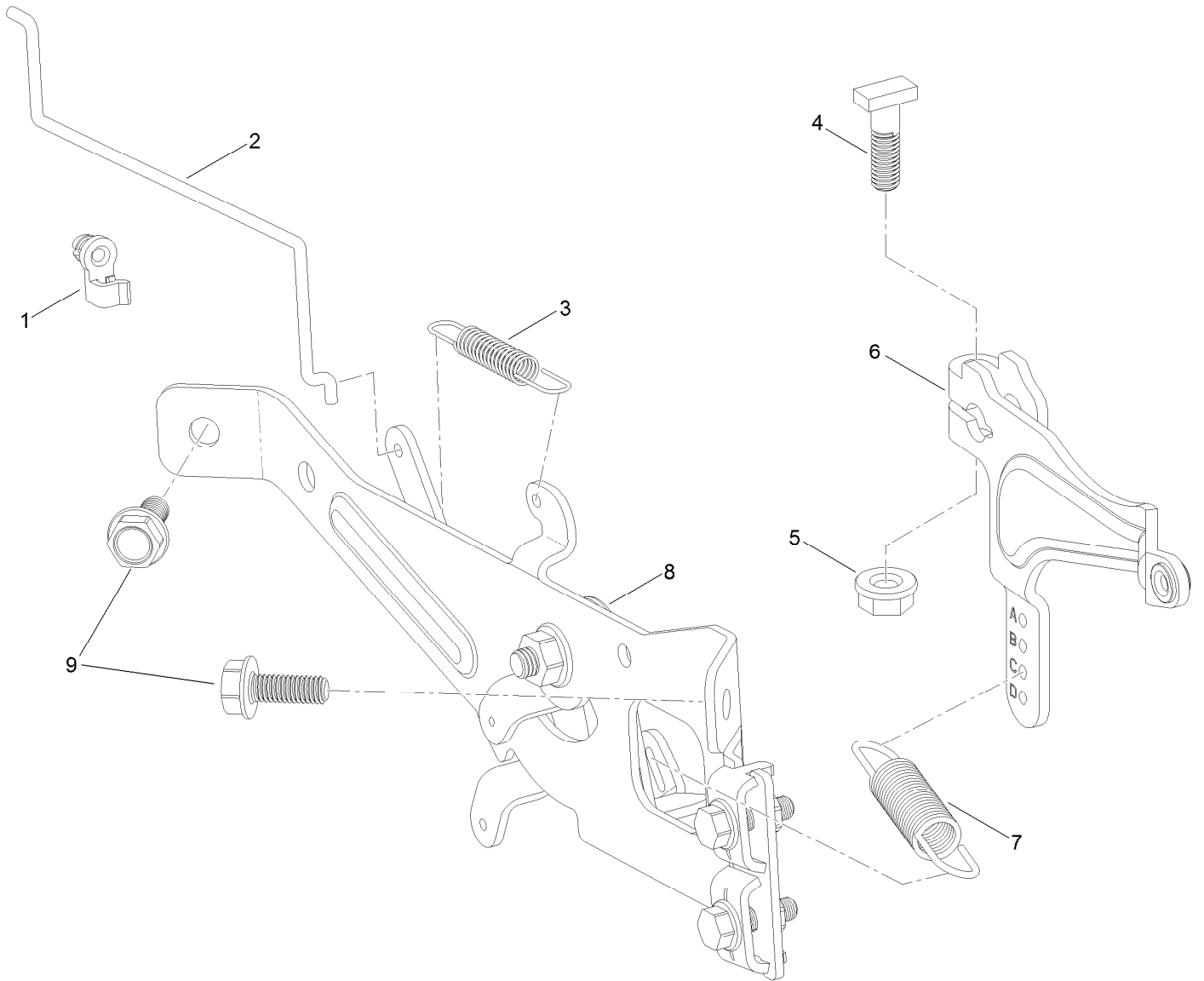

## Governor Control Assembly (continued)

<i>Ref.</i>	<i>Part Number</i>	<i>Qty.</i>	<i>Description</i>	<i>Ref.</i>	<i>Part Number</i>	<i>Qty.</i>	<i>Description</i>
1	127-9250	1	Clip-Linkage	6	127-9239	1	Arm-Governor
2	127-9242	1	Linkage-Choke	7	133-9809	1	Spring-Governor
3	127-9241	1	Spring-Governor	8	133-1570	1	Control Plate ASM
4	120-4238	1	Bolt-Arm, Governor	9	120-4232	2	Screw-HHF
5	120-4236	1	Nut-Flange				

# Piston and Cylinder Head Assembly

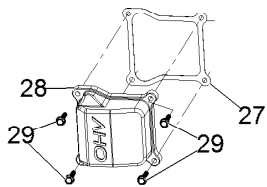
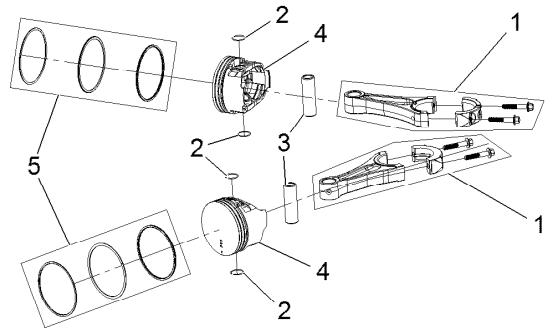
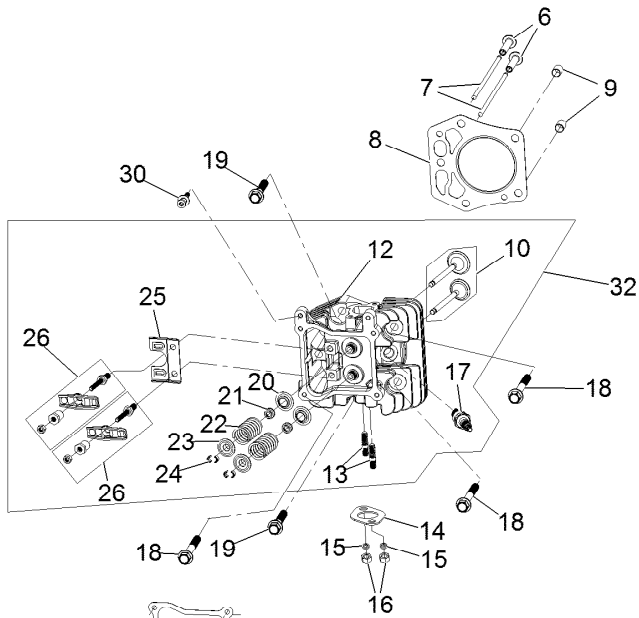
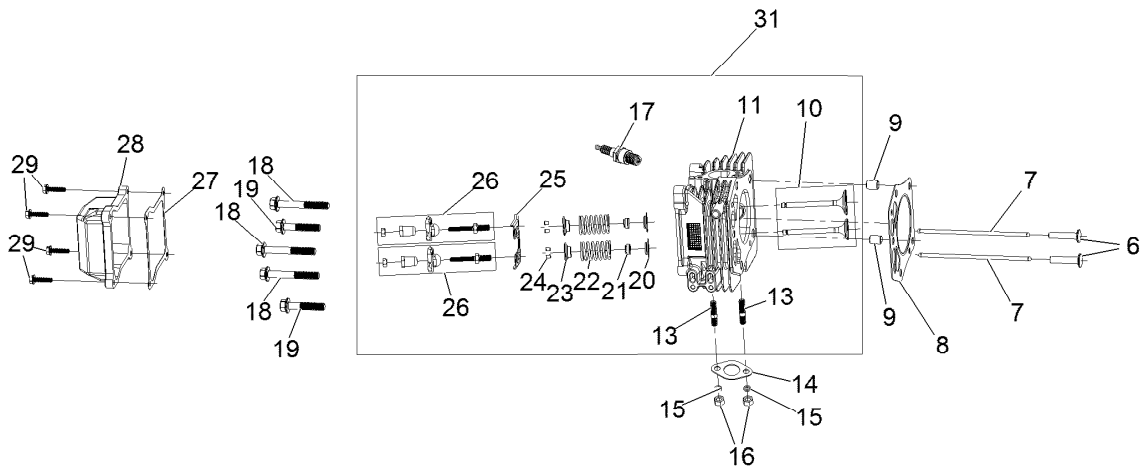

## Piston and Cylinder Head Assembly (continued)

<i>Ref.</i>	<i>Part Number</i>	<i>Qty.</i>	<i>Description</i>	<i>Ref.</i>	<i>Part Number</i>	<i>Qty.</i>	<i>Description</i>
1	127-9256	2	Connecting Rod ASM	17	81-3250	2	Spark Plug
2	127-9258	4	Clip-Pin, Piston	18	127-9231	6	Screw-HWH
3	127-9257	2	Pin-Piston	19	127-9232	4	Screw-HWH
4	127-9259	2	Piston	20	120-4303	4	Seat-Spring, Valve
5	127-9260	2	Piston Ring Set	21	120-4304	4	Seal-Stem, Valve
6	127-9224	4	Lifter-Valve	22	120-4305	4	Spring-Valve
7	127-9225	4	Rod-Push	23	120-4306	4	Retainer-Spring, Valve
8	127-9226	2	Gasket-Head, Cylinder	24	120-4307	8	Keeper-Valve
9	127-9227	4	Pin-Dowel	25	127-9233	2	Plate-Guide, Push Rod
10	127-9228	2	Valve Set	26	127-9294	4	Rocker Arm ASM
11	133-9802	1	Head-Cylinder, Right	27	127-9295	2	Gasket-Valve Cover
12	133-9804	1	Head-Cylinder, Left	28	127-9050	2	Cover-Valve
13	121-0464	4	Stud-Exhaust	29	120-4225	8	Screw-HHF
14	120-4317	2	Gasket-Exhaust	30	120-4214	1	Screw-Shoulder, HH
15	127-9279	4	Washer-Lock, Split	31	133-9819	1	Right Head ASM
16	121-0199	4	Nut-HH	32	133-9820	1	Left Head ASM

# Blower Housing Assembly

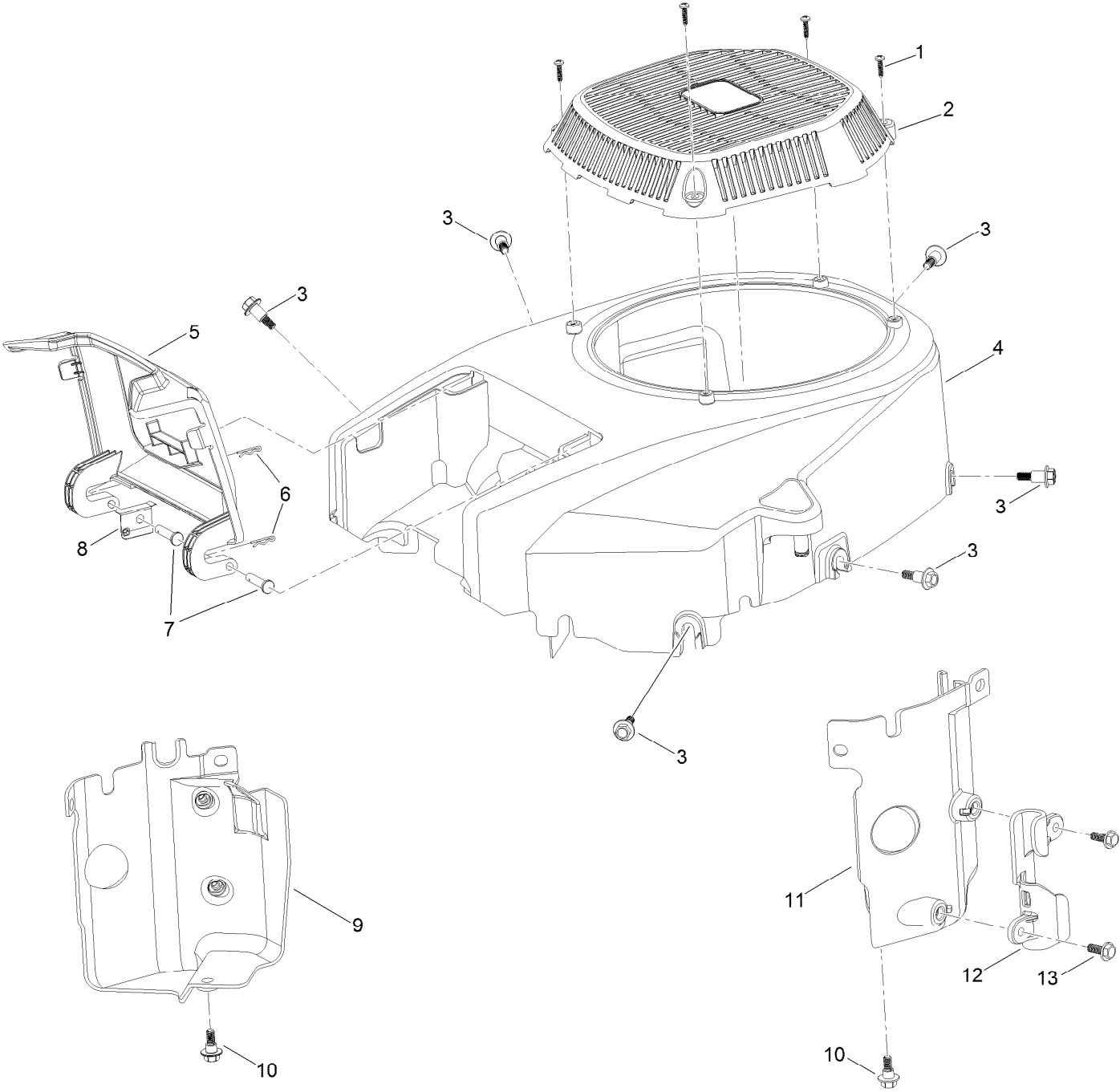

## Blower Housing Assembly (continued)

<i>Ref.</i>	<i>Part Number</i>	<i>Qty.</i>	<i>Description</i>	<i>Ref.</i>	<i>Part Number</i>	<i>Qty.</i>	<i>Description</i>
1	133-1571	4	Screw-PPH, Plastic	8	127-9281	1	Plate-Spring
2	127-9045	1	Cover-Fan	9	127-9049	1	Baffle-Air, Left
3	127-9196	6	Screw-Shoulder, HWH	10	120-4210	2	Screw-Shoulder, HHF
4	133-1572	1	Shroud-Engine	11	127-9048	1	Baffle-Air, Right
5	127-9046	1	Door-Filter, Air	12	127-9287	1	Cleat-Hose
6	127-9280	2	Pin-Hair	13	120-4232	2	Screw-HHF
7	127-9282	2	Pin				

# Gasket and Seal Kit

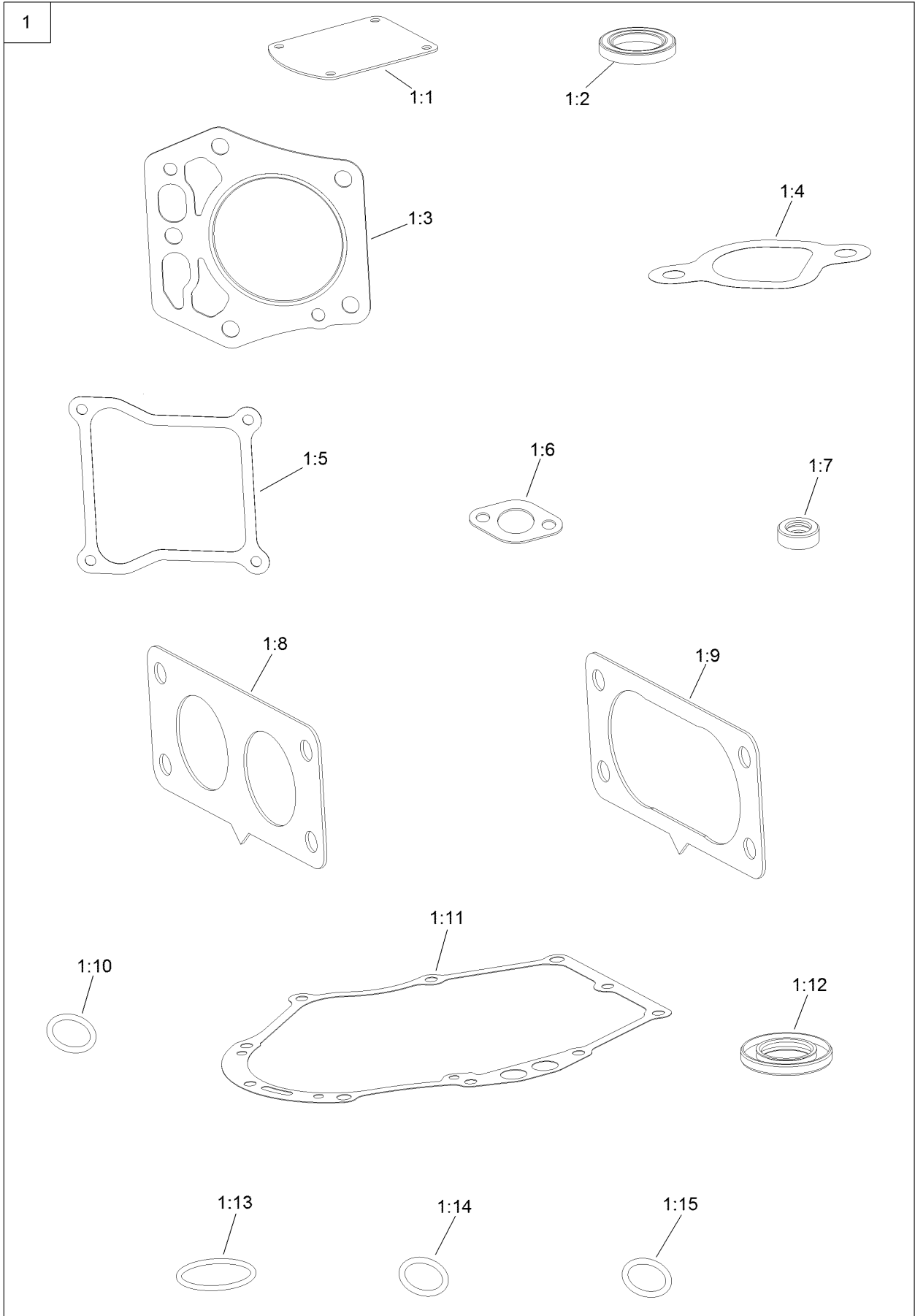



## Gasket and Seal Kit (continued)

<i>Ref.</i>	<i>Part Number</i>	<i>Qty.</i>	<i>Description</i>	<i>Ref.</i>	<i>Part Number</i>	<i>Qty.</i>	<i>Description</i>
1	127-9296	1	Gasket And Seal Kit	1:8	127-9246	2	Gasket-Carburetor
1:1	127-9214	1	Gasket-Breather	1:9	127-9251	1	Gasket-Carburetor
1:2	120-4267	1	Seal-Oil	1:10	120-4262	2	O-Ring
1:3	127-9226	2	Gasket-Head, Cylinder	1:11	127-9267	1	Gasket-Cover, Crankcase
1:4	127-9230	2	Gasket-Intake	1:12	127-9271	1	Seal
1:5	127-9295	2	Gasket-Valve Cover	1:13	127-9273	1	O-Ring
1:6	120-4317	2	Gasket-Exhaust	1:14	127-9284	1	O-Ring
1:7	120-4257	1	Seal-Oil	1:15	127-9286	1	O-Ring

# Hydro Transaxle Drive Assembly

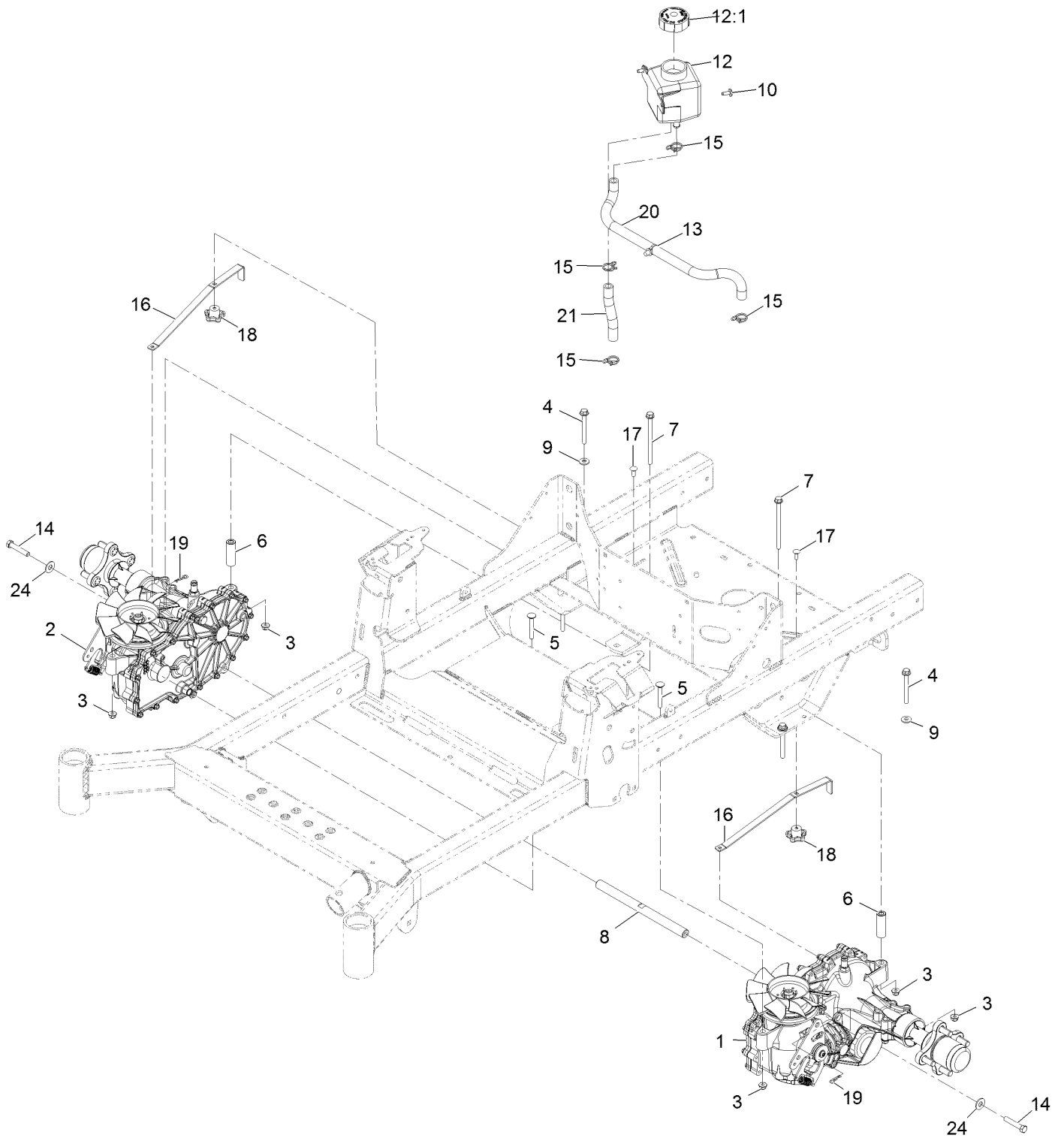

## Hydro Transaxle Drive Assembly (continued)

<i>Ref.</i>	<i>Part Number</i>	<i>Qty.</i>	<i>Description</i>	<i>Ref.</i>	<i>Part Number</i>	<i>Qty.</i>	<i>Description</i>
1	126-4882	1	Transaxle ASM	12	109-2250	1	Vent-Tank, HYD
2	126-4883	1	Transaxle ASM	12:1	109-3320	1	Cap-Reservoir, HYD
3	104-8300	8	Nut-Nyloc 5/16-18 Flg	13	32180-118	1	Clip-Tie
4	126-4687	4	Screw-HHF ●	14	94-7972	2	Screw-HH W/Loctite
5	3230-7	2	Bolt-Carriage 5/16-18 X 2 1/4	15	126-0327	4	Clamp-Hose
6	116-5809	2	Spacer-Hydro	16	109-5395	2	Arm-Bypass, Hydro
7	126-5896	2	Screw HHF	17	3229-1	2	Bolt-Carriage 1/4-20 X 3/4
8	116-6833	1	Shaft-Spacer	18	108-6402	2	Knob-Handle
9	1-303334	4	Washer-Spring Disc 5/16	19	1-806003	2	Hairpin-Cotter
10	126-6266	2	Screw-1/4-20 X .65 Torx Plus	20	126-5668	1	Hose-Hydraulic
				21	126-5669	1	Hose-Hydraulic
				24	3256-4	2	Washer-3/8 Std

● Use Pro-Lock, Nut Type (P/N 1-840022, .5ml tube) on threads.

# LH Transaxle Assembly

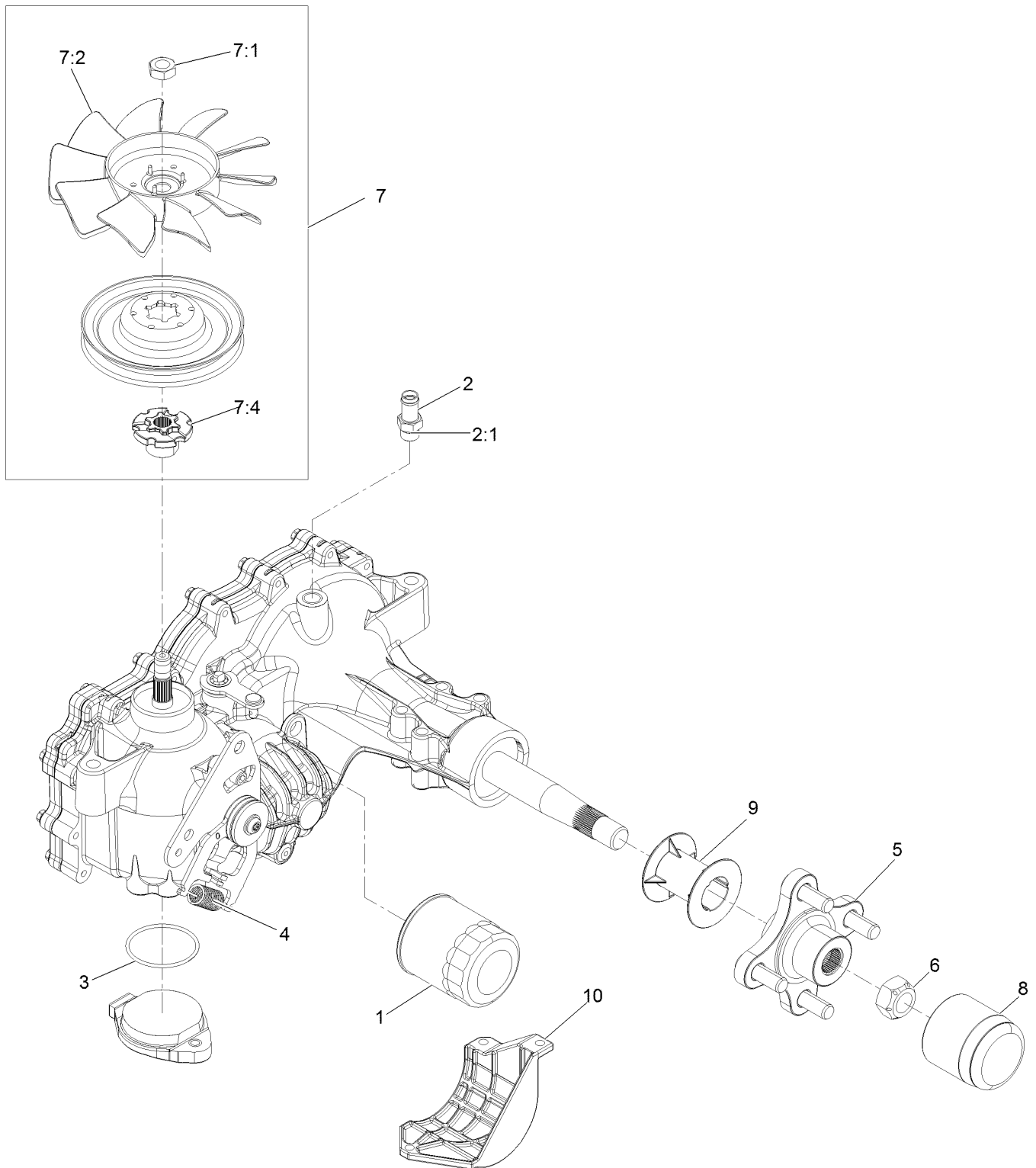

## LH Transaxle Assembly (continued)

<i>Ref.</i>	<i>Part Number</i>	<i>Qty.</i>	<i>Description</i>	<i>Ref.</i>	<i>Part Number</i>	<i>Qty.</i>	<i>Description</i>
1	109-3321	1	Filter-Hydraulic	7:1	116-9714	1	Nut-HJ
2	109-3278	1	Adapter-Straight	7:2	126-0226	1	Fan
2:1	237-42	1	O-Ring	7:4	116-9705	1	Hub-Pulley
3	109-3540	1	O-Ring-Charge Seal Cover	8	116-6214	1	Cap-Axle, Long
4	109-5592	1	Spring	9	116-6213	1	Tube-Axle
5	116-3872	1	Hub-Offset	10	120-7979	1	Guard-Filter, LH
6	109-3536	1	Nut-Hub	99	109-3537	1	Seal Kit ●
7	125-0059	1	Fan And Pulley Kit				

● Not illustrated

# RH Transaxle Assembly

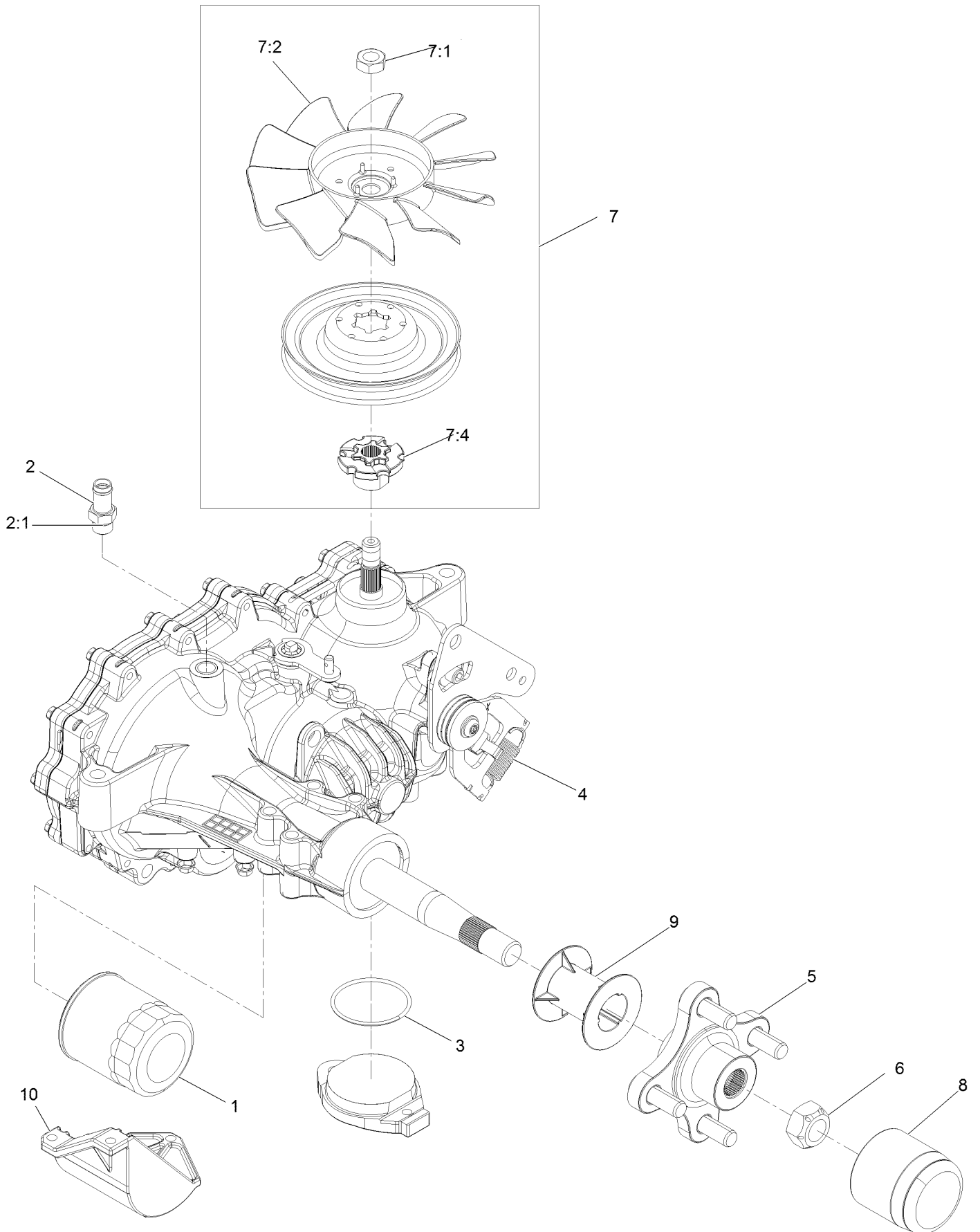

## RH Transaxle Assembly (continued)

<i>Ref.</i>	<i>Part Number</i>	<i>Qty.</i>	<i>Description</i>	<i>Ref.</i>	<i>Part Number</i>	<i>Qty.</i>	<i>Description</i>
1	109-3321	1	Element-Oil Filter, HYD	7:1	116-9714	1	Nut-HJ
2	109-3278	1	Adapter-Straight	7:2	126-0226	1	Fan
2:1	237-42	1	O-Ring	7:4	116-9705	1	Hub-Pulley
3	109-3540	1	O Ring-Seal	8	116-6214	1	Cap-Axle, Long
4	109-5592	1	Spring-Extension	9	116-6213	1	Tube-Axle
5	116-3872	1	Hub-Offset	10	120-7981	1	Guard-Filter, RH
6	109-3536	1	Nut-Hub	99	109-3537	1	Seal Kit ●
7	125-0059	1	Fan And Pulley Kit				

● Not illustrated

# Electrical Assembly

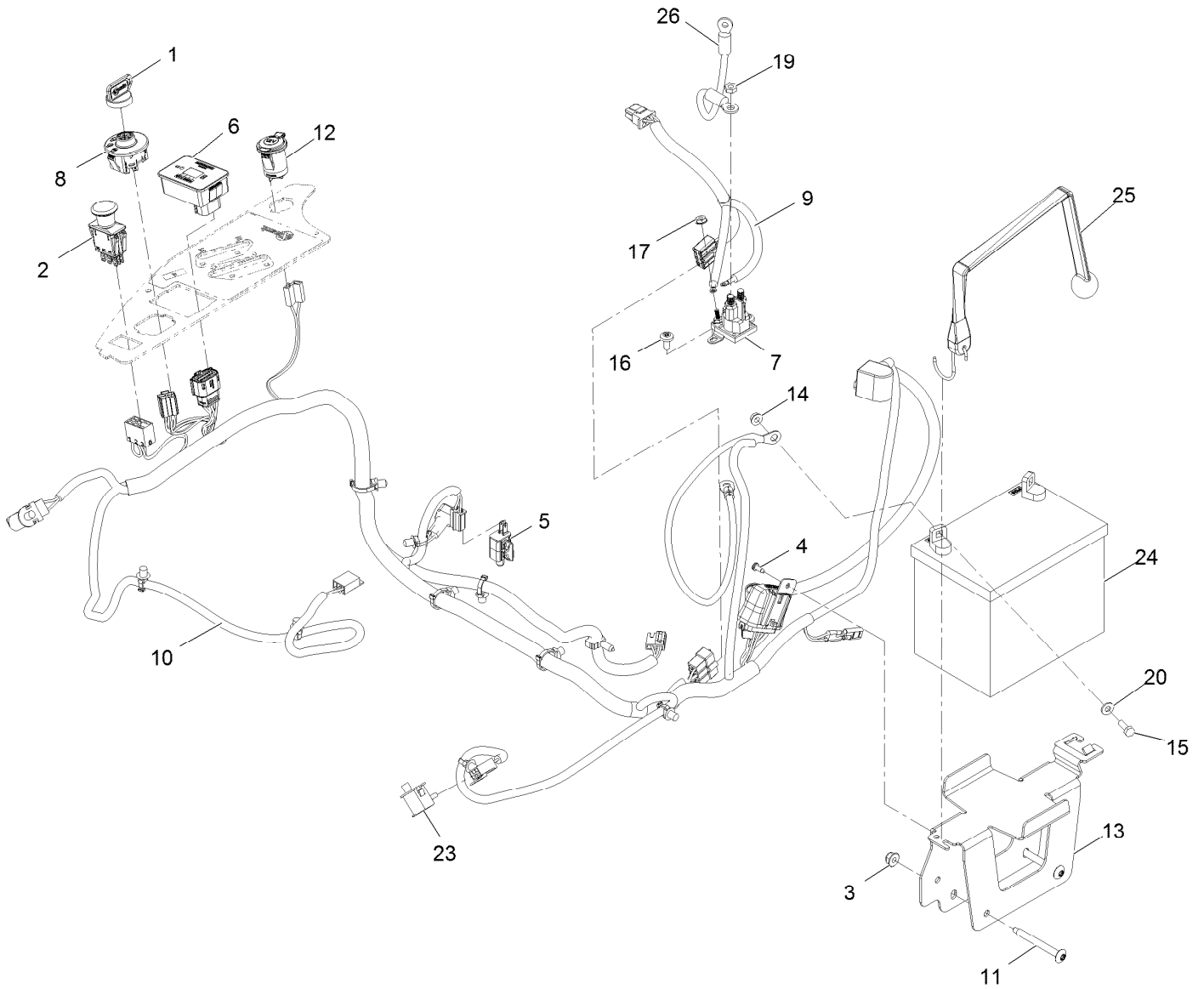



## Electrical Assembly (continued)

<i>Ref.</i>	<i>Part Number</i>	<i>Qty.</i>	<i>Description</i>	<i>Ref.</i>	<i>Part Number</i>	<i>Qty.</i>	<i>Description</i>
1	1-603511	1	Key-Ignition	12	126-6499	1	Port-Power, 12V
1	103-2106	1	Key-Exmark Logo	13	126-6725-03	1	Tray-Battery
2	103-5221	1	Switch-PTO	14	32128-33	2	Nut-Whizlock 1/4-20
3	104-8300	2	Nut-Nyloc 5/16-18 Flg	15	321-4	2	Screw-HH 1/4-20 X 3/4
4	105-6849	1	Screw-Tph #10-24 X 1/2 Tf	16	126-6266	2	Screw-1/4-20 X .65 Torx Plus
5	110-6765	1	Switch	17	32149-8	2	Nut-Keps 10-32 Unf Yz
6	116-5609	1	Module ASM	19	3220-2	1	Nut-Jam 5/16-24
7	117-1197	1	Solenoid	20	3256-22	2	Washer-1/4 SAE
8	117-2221	1	Switch-Ignition	23	82-2190	2	Switch
9	126-5036	1	Adapter-Harness, Wire	24		1	Battery (300 CCA, Wet) ●
10	126-5803	1	Harness-Wire ■	25	126-7627	1	Strap-Bungee
11	126-6267	2	Screw-Truss HD 5/16-18 X 2 3/4 Torx Plus	26	100-3540	1	Cable-Battery, Positive

● Not serviced separately

■ Use dielectric grease on all unsealed connectors and terminals only. Do not apply in sealed connectors.

# Harness Assembly

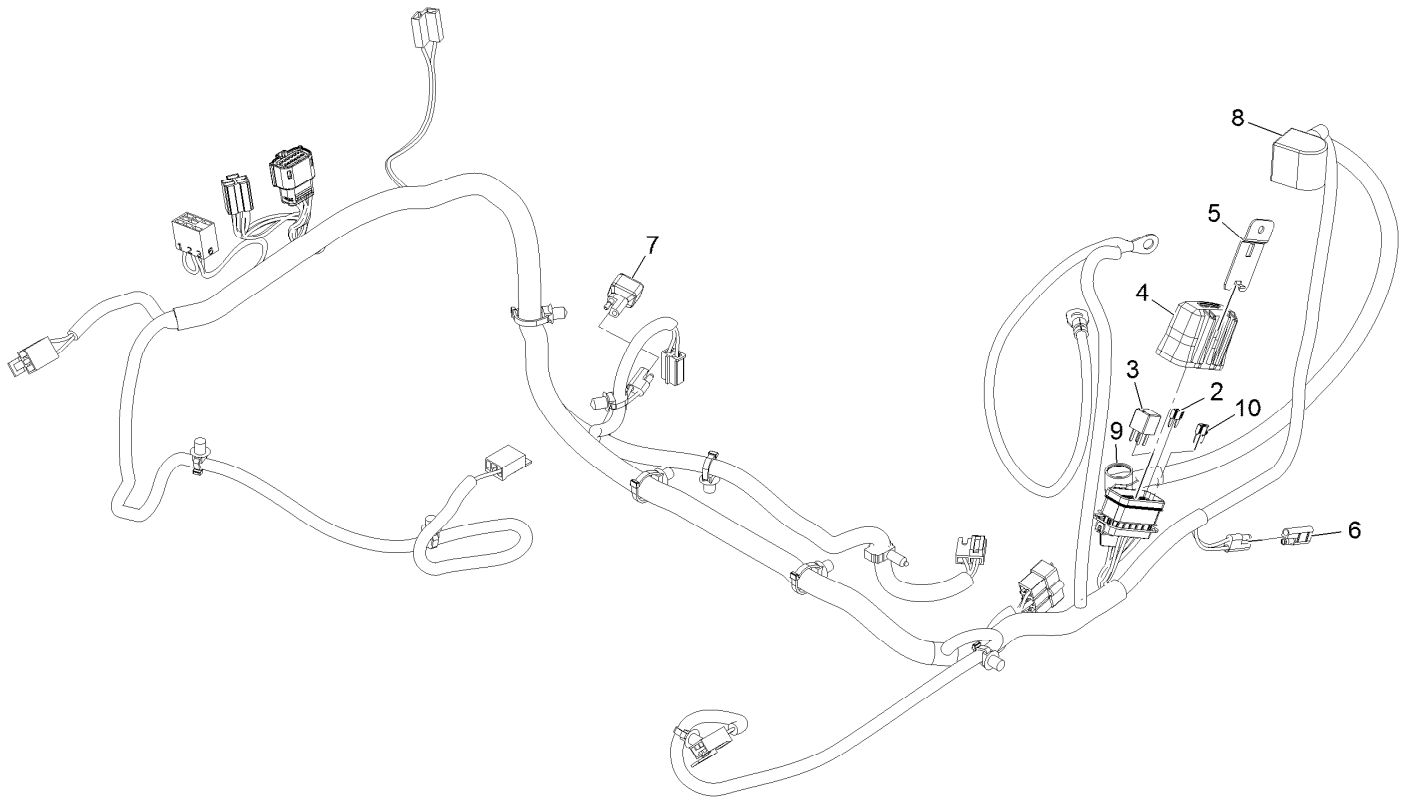

## Harness Assembly (continued)

<i>Ref.</i>	<i>Part Number</i>	<i>Qty.</i>	<i>Description</i>	<i>Ref.</i>	<i>Part Number</i>	<i>Qty.</i>	<i>Description</i>
2	121-8868	1	Fuse-Mini Blade, 20 Amp	7	103-3895	1	Diode
3	126-3991	1	Relay-Micro	8	126-8876	1	Insulator-Battery
4	32180-176	1	Cover-Block, Fuse	9	1-543393	1	Insulator-Solenoid
5	32180-177	1	Clip-Mounting	10	121-8867	1	Fuse-Mini Blade, 15 Amp
6	116-0053	1	Cap-Plug				

**Notes:**

**Notes:**

**Notes:**



# MAXIMIZE THE PERFORMANCE OF YOUR EXMARK MACHINE.



## EXMARK® PREMIUM ENGINE OIL

Exmark now offers a family of engine oil viscosities to perform well in any environment. Each viscosity has the same synthetic formulation to give you what you need in punishing conditions. We designed each grade to the highest quality, making it ideal even for diesel applications. Coupled with Exmark Premium Fuel Treatment, we have the performance products to make your machine hum.

### EXMARK PREMIUM ENGINE OIL SAE 30/10W-30

- Meets zero shear requirements of a straight grade SAE 30 as well as the cold temp properties of a 10W-30.
- Most versatile oil in the industry.
- Superior corrosion protection over conventional oil - even in corrosive, humid environments.

### EXMARK PREMIUM ENGINE OIL SAE 20W-50

- Perfect for your big block engine, or any application in severe service.
- Same full synthetic formulation as all other Exmark Premium viscosities.
- Also effective for use in severe service small block engines.

### EXMARK PREMIUM ENGINE OIL SAE 10W-50

- Full synthetic formulation gives you peak performance. Don't settle for less.
- Wide span multi-grade combines easy starting in cold weather with maximum protection in high temperature operation.
- Reduce friction & wear over standard mineral formulations.

### EXMARK PREMIUM ENGINE OIL SAE 0W-40

- The perfect choice for when the weather turns cold or unpredictable, and your Exmark UTV has to perform.
- Commercial quality for severe service.
- Advanced additive package helps prevent corrosion from long-term storage.

### EXMARK PREMIUM ENGINE OIL UTV FORMULATION

- 4-cycle high-temp formulation.
- Heavier viscosity, full synthetic, perfect for your UTV.

### EXMARK PREMIUM UTV EXTREME CONDITIONS GEAR OIL

- SAE 80W-90, designed to keep your UTV performing at its peak.
- Shear stable, hypoid gear lube.
- Includes a premium additive system to combat wear, oxidation, rust & corrosion.

*Available from your local Exmark dealer. Find your closest dealer at [exmark.com](http://exmark.com)*

## EXMARK ACCESSORIES AND OPTIONS\*

### MID-MOUNT RIDING ACCESSORIES AND OPTIONS

CUSTOM RIDE SEAT SUSPENSION SYSTEM	OPERATOR CONTROLLED DISCHARGE
FULL SUSPENSION SEAT	SUN SHADE
DECK LIFT ASSIST KIT	TRASH CONTAINER
HITCH KIT	TURF STRIPER
LIGHT KIT	ULTRA VAC COLLECTION SYSTEM
12V POWER PORT	ULTRA VAC QUICK DISPOSAL SYSTEM
MICRO-MULCH SYSTEM	

### OUT-FRONT RIDING ACCESSORIES AND OPTIONS

CUSTOM RIDE SEAT SUSPENSION SYSTEM	SNOW BLADE
DUAL-TAIL WHEEL	SNOWBLOWER
FLOOR PAN EXTENDER	SUN SHADE
HITCH KIT	TRASH CONTAINER
LIGHT KIT	ULTRA VAC COLLECTION SYSTEM
MICRO-MULCH SYSTEM	ULTRA VAC QUICK DISPOSAL SYSTEM
ROLL OVER PROTECTION SYSTEM (ROPS)	WEATHER CAB

### WALK-BEHIND ACCESSORIES AND OPTIONS

GRASS CATCHER	TURF STRIPER
MICRO-MULCH SYSTEM	STANDON

\*Some accessories and options not available for some models.

Place Model No. and Serial No.  
Label Here (Included in the Literature  
Pack) or Fill in Below

Model No. \_\_\_\_\_

Serial No. \_\_\_\_\_

Date Purchased \_\_\_\_\_

Engine Model No. and Spec. No. \_\_\_\_\_

Engine Serial No. (E/No) \_\_\_\_\_

© 2017 Exmark Mfg. Co., Inc.  
Industrial Park Box 808  
Beatrice, NE 68310  
All Rights Reserved

Part No. 4502-912 Rev. B  
(402) 223-6375  
Fax (402) 223-5489  
Printed in the USA.

