

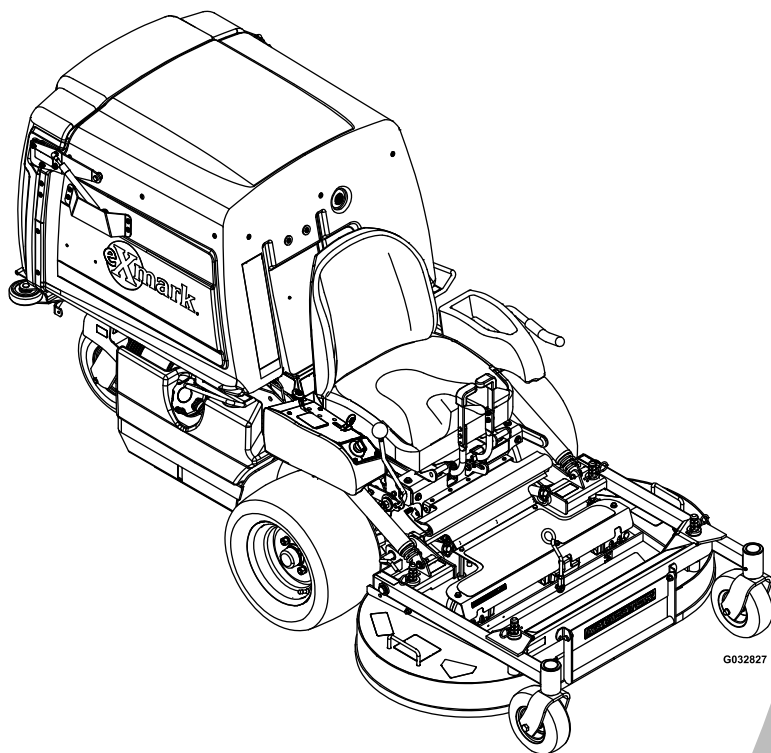

NAVIGATOR®

Model No. NVS730AKC48000—Serial No. 31600000 and Up

Picture below may not reflect actual product.



Parts Manual

Part No. 4502-727 Rev. A

Ordering Replacement Parts

To order replacement parts, please supply the part number, the quantity, and the description of each part desired.

Understanding Reference Numbers

Each identified part in an illustration has a reference number. The reference number for a part also appears in the parts list, along with other information about the part.

This catalog uses two special reference number formats, one to indicate parts in a service assembly and another to indicate the quantity of a given part in an illustration.

Service Assembly Reference Numbers

Parts in service assemblies have reference numbers in the form a:b. The a represents the reference number of the entire service assembly and the b represents a sequential number unique to each part within the service assembly.

For example, a wheel assembly might be identified by reference number 6, the tire by 6:1, the valve by 6:2, and the wheel by 6:3. When you order the assembly identified by reference number 6, you receive all parts identified by reference numbers 6:1, 6:2, and 6:3. However, you may also order any part individually. Reference numbers of this type appear in illustration and in parts lists.

Reference Numbers Indicating Quantity

In an illustration, if a reference number indicates more than one part, the reference number has the form nX y. The n represents the quantity of the part, the X is the multiplication symbol, and the y represents the reference number.

For example, in an illustration, the reference number 2X 37 means that two of the parts identified by reference number 37 are indicated.

List of Abbreviations

| | | |
|--|--|--|
| AR: as required | HLH: hex lag head | PTH: phillips truss head |
| ASM: assembly | HOC: height-of-cut | PTO: power-take-off |
| BBC: blade brake control | HP: high pressure | RH: right hand |
| BHTF: button head thread forming | HSBH: hex socket button head | ROPS: roll-over protection system |
| CARR: carriage | HSFH: hex socket flat head | RRB: rear roller brush |
| CCW: counter clockwise | HSH: hex socket head | SFH: slotted fillister head |
| CW: clockwise | HWH: hex washer head | SHH: slotted hex head |
| DEG: degrees | HWHTF: hex washer head thread forming | SHWH: slotted hex washer head |
| DPA: Dual Point Adjustment | HYD: hydraulic | SPH: slotted pan head |
| ECM: electronic control module | LH: left hand | SQH: square head |
| EXT: external | LP: low pressure | SRH: slotted round head |
| FH: flat head | LPG: Liquefied Petroleum Gas | STD: standard |
| GA: gauge | NI: nylon insert | TAP: self tapping |
| HD: heavy-duty | NPTF: national pipe thread fine | TTH: torx truss head |
| HF: hex flange | PFH: phillips flat head | |
| HH: hex head | PPH: phillips pan head | |
| HHF: hex head flange | PPHTF: phillips pan head thread forming | |
| HHFTF: hex head flange thread forming | PRH: phillips round head | |
| HJ: hex jam | | |

Touch Up Paint

Exmark black touch up spray paint – gloss black.

Exmark red touch up paint (spray paint – P/N 1-850337 - .6 oz liquid bottle – P/N 103-9140).



If your Exmark dealer does not have the Exmark part in stock, Exmark will get the parts to the dealer the next business day or the part will be FREE Guaranteed!! (Some restrictions apply. See your participating Exmark Dealer for details.)

Contents

| | |
|---|----|
| Complete Deck and Support Frame Assembly | 4 |
| Deck Assembly | 6 |
| Deck Decal Assembly No. 109-4372 | 8 |
| Discharge Tube Assembly No. 103-9487 | 10 |
| Gearbox Assembly No. 103-3387 | 12 |
| Rear Deck Height Adjustment Assembly No. 109-0323 | 14 |
| Deck Support Frame Assembly | 16 |
| Deck Support W/Decals Assembly No. 103-9480 | 18 |
| Spring Lift Assist Assembly No. 116-7851 | 20 |
| Seat and Consoles Assembly | 22 |
| Main Frame Assembly | 24 |
| Parking Brake Assembly | 26 |
| Speed Control Assembly | 28 |
| Fuel Assembly | 30 |
| Blower Mounting Assembly | 32 |
| Blower Assembly No. 116-9649 | 34 |
| Drive Assembly | 36 |
| Engine Assembly | 38 |
| Hydraulic Assembly | 40 |
| Hydraulic Pump Assembly No. 116-7836 | 42 |
| Idler Assembly No. 103-7349 | 44 |
| Hopper Assembly | 46 |
| Hopper Assembly No. 103-9457 | 48 |
| Hopper Door Assembly No. 103-9456 | 50 |
| Hopper Screen Assembly No. 109-0717 | 52 |
| Hopper Frame Assembly No. 109-4086 | 54 |
| Fill Sensor Assembly No. 103-9466 | 56 |
| Electrical Assembly | 58 |

Complete Deck and Support Frame Assembly

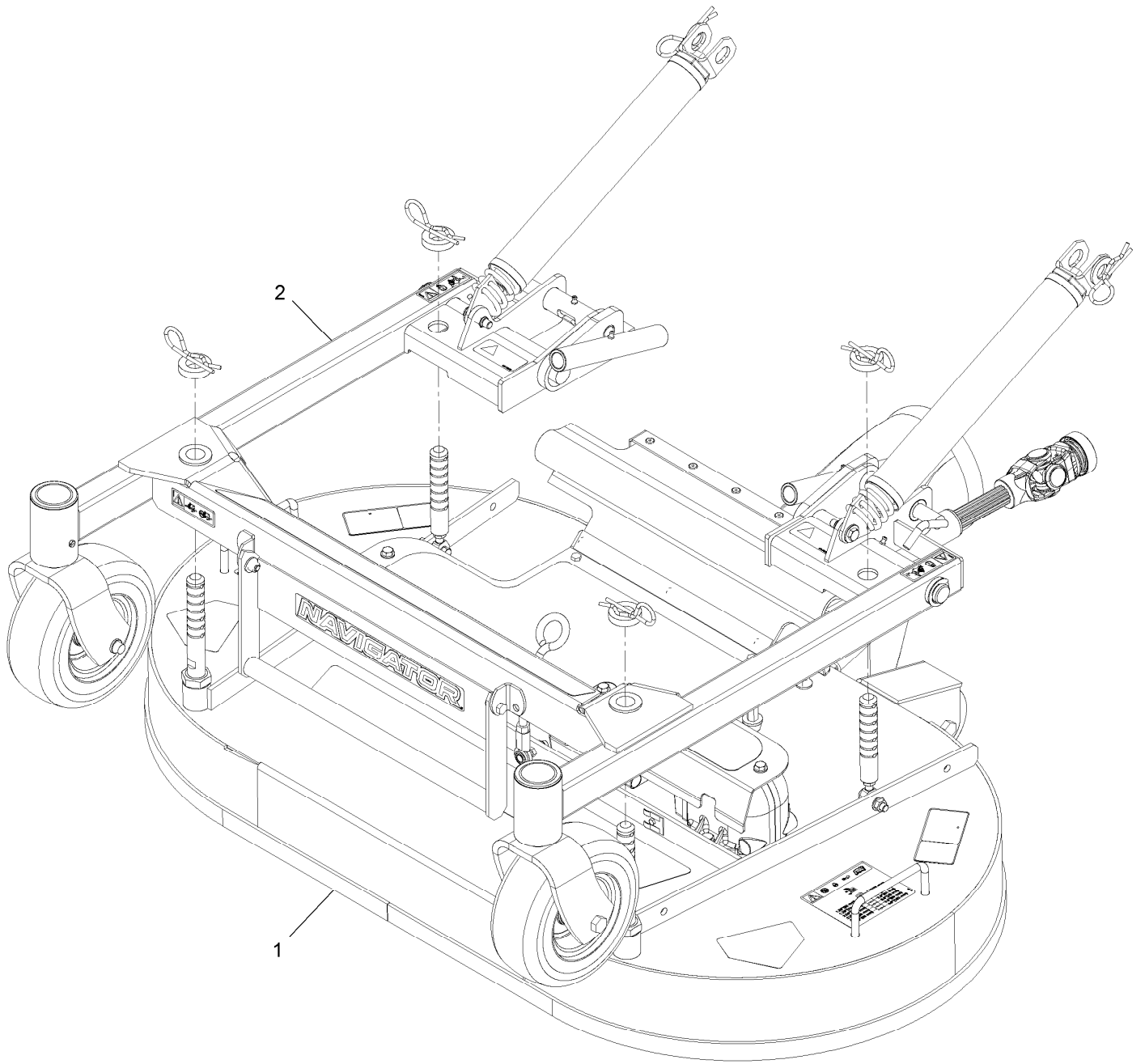

Complete Deck and Support Frame Assembly (continued)

| <i>Ref.</i> | <i>Part Number</i> | <i>Qty.</i> | <i>Description</i> |
|-------------|--------------------|-------------|------------------------|
| 1 | 116-7833 | 1 | Deck ASM |
| 2 | 116-7841 | 1 | Deck Support Frame ASM |

Deck Assembly (continued)

| <i>Ref.</i> | <i>Part Number</i> | <i>Qty.</i> | <i>Description</i> | <i>Ref.</i> | <i>Part Number</i> | <i>Qty.</i> | <i>Description</i> |
|-------------|--------------------|-------------|----------------------------------|-------------|--------------------|-------------|-------------------------------|
| 1 | 109-4372 | 1 | Deck Decal And Baffle ASM | 21 | 103-4208 | 1 | Blade, RH (48") Red |
| 2 | 103-9487 | 1 | Discharge Tube ASM | 22 | 103-4207 | 1 | Blade, LH (48") Black |
| 3 | 109-0321 | 2 | Front Deck Height Adjust ASM | 23 | 30-8770 | 2 | Washer |
| 3:1 | 1-413425 | 1 | Spacer-Deck Support | 24 | 99-0283 | 4 | Bolt-Shear 1/4-20 X 7/8 |
| 3:2 | 103-7353 | 1 | Pin-Cut Height | 25 | 3296-42 | 4 | Nut-Nyloc 1/4-20 |
| 3:3 | 103-8496 | 1 | Nut-Jam 7/8-9 | 26 | 92-5816 | 2 | Bolt-Blade 1/2-20 X 2 1/4 |
| 4 | 103-3387 | 1 | Gear Box ASM | 27 | 103-3700 | 2 | Roller-Deck |
| 5 | 103-9496 | 1 | Asm, Gearbox Cover W/Decal (48") | 28 | 103-4230 | 2 | Spacer-Roller |
| 5:2 | 103-8629 | 1 | Pad-Anti Skid | 29 | 325-14 | 2 | Screw-HH 1/2-13 X 3 1/2 |
| 5:3 | 119-0217 | 1 | Decal-Danger | 30 | 32128-49 | 2 | Nut-Whizlock 1/2-13 |
| 5:4 | 126-7281 | 1 | Decal-Commercial 48 | 31 | 323-7 | 4 | Screw-HH 3/8-16 X 1 1/4 |
| 6 | 103-8363 | 1 | Deck Latch ASM | 32 | 3290-357 | 4 | Nut-Whizlock 3/8-16 |
| 6:1 | 103-7994 | 1 | Balljoint | 33 | 67-7490 | 1 | Key-Machine 1/4 X 1/4 X 1 1/2 |
| 6:2 | 103-8307 | 1 | Latch-Deck | 34 | 103-9485 | 1 | Drive Shaft ASM |
| 6:3 | 3219-3 | 1 | Nut-Hex 3/8-24 | 34:1 | | 1 | Drive Shaft-Telescoping ● |
| 6:4 | 3296-6 | 1 | Nut-Nyloc 3/8-24 | 34:1:1 | 54-9180 | 2 | U-Joint Kit |
| 7 | 109-0323 | 2 | Rear Deck Height Adjust ASM | 34:1:1:1 | 62-3820 | 1 | Fitting-Grease |
| 8 | 1-803075 | 3 | Screw-Truss Head #10-24 X 3/4 | 34:1:2 | 103-9328 | 1 | Yoke-Keyed |
| 9 | 3296-2 | 6 | Nut-Nyloc #10-24 | 34:1:3 | 103-9329 | 1 | Yoke-Quick Disconnect |
| 10 | 116-7843-01 | 1 | Guard-Drive Shaft | 34:2 | 116-9049 | 1 | Decal-Danger Driveline |
| 11 | 322-5 | 3 | Screw-HH 5/16-18 X 1 | 35 | 3247-2 | 1 | Setscrew-3/8-16 X 3/8 |
| 12 | 3296-29 | 3 | Nut-Nyloc 5/16-18 | 36 | 323-9 | 1 | Screw-HH 3/8-16 X 1 3/4 |
| 13 | 103-6290-03 | 1 | Strap-Drive, Line Cover | 37 | 3296-39 | 1 | Nut-Nyloc 3/8-16 |
| 14 | 103-6183-03 | 1 | Bracket-Guard, PTO | 38 | 3256-23 | 3 | Washer-5/16 Sae |
| 15 | 103-5979 | 1 | Guard-PTO | 39 | 322-3 | 3 | Screw-HH 5/16-18 X 3/4 |
| 16 | 114439 | 5 | Rivet | 40 | 103-8841 | 1 | Spring-Extension |
| 17 | 3256-14 | 5 | Washer-#10 Std | 41 | 1-513690 | 1 | Clip-Deck, Hold Up Rod |
| 18 | 1-808280 | 2 | Pin-Clevis 5/16 X 1 49/64 | 42 | 3290-134 | 1 | Screw-HH Machine 10-24 X 5/8 |
| 19 | 1-806003 | 2 | Hairpin-Cotter | 43 | 103-8610 | 2 | Stand-Off |
| 20 | 103-7705 | 2 | Driver-Blade | 44 | 1-523420 | 2 | Bumper |
| | | | | 45 | 321-2 | 2 | Screw-HH 1/4-20 X 1/2 |

● Not serviced separately

Deck Decal Assembly No. 109-4372

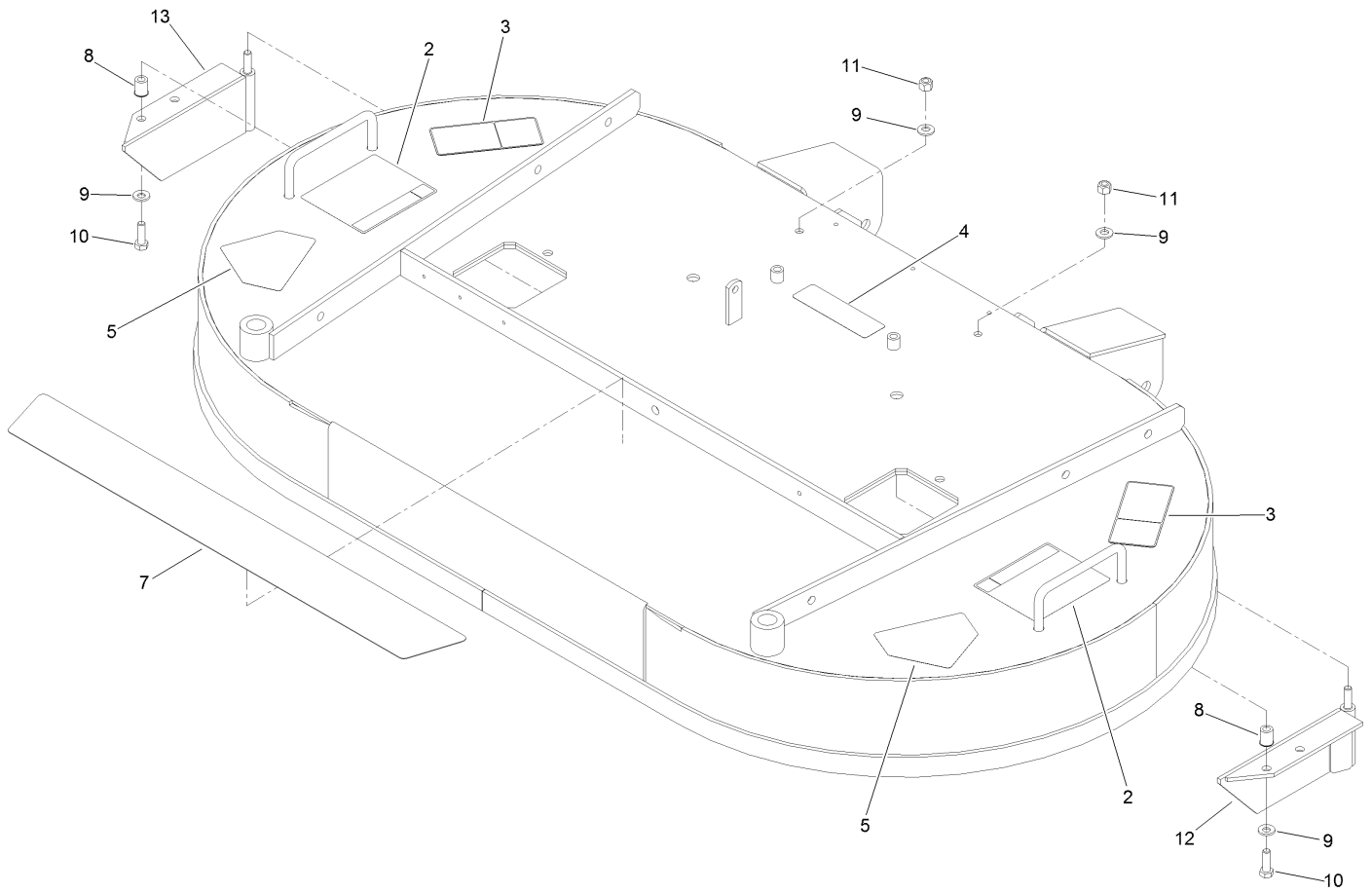

Deck Decal Assembly No. 109-4372 (continued)

| <i>Ref.</i> | <i>Part Number</i> | <i>Qty.</i> | <i>Description</i> | <i>Ref.</i> | <i>Part Number</i> | <i>Qty.</i> | <i>Description</i> |
|-------------|--------------------|-------------|--------------------------|-------------|--------------------|-------------|--------------------|
| 2 | 116-8934 | 2 | Decal-Cutting Height Adj | 9 | 1-303334 | 4 | Washer-Spring |
| 3 | 93-7818 | 2 | Decal-Torque, Blade Bolt | 10 | 322-5 | 2 | Screw-HH |
| 4 | 112-9028 | 1 | Decal-Missing, Cover | 11 | 3296-29 | 2 | Nut-Lock, NI |
| 5 | 112-8760 | 2 | Decal-Danger | 12 | 109-4053-01 | 1 | Baffle-LH |
| 7 | 103-8630 | 1 | Pad-Anti Skid | 13 | 109-4054-01 | 1 | Baffle-RH |
| 8 | 32148-7 | 4 | Nut-Insert | | | | |

Discharge Tube Assembly No. 103-9487

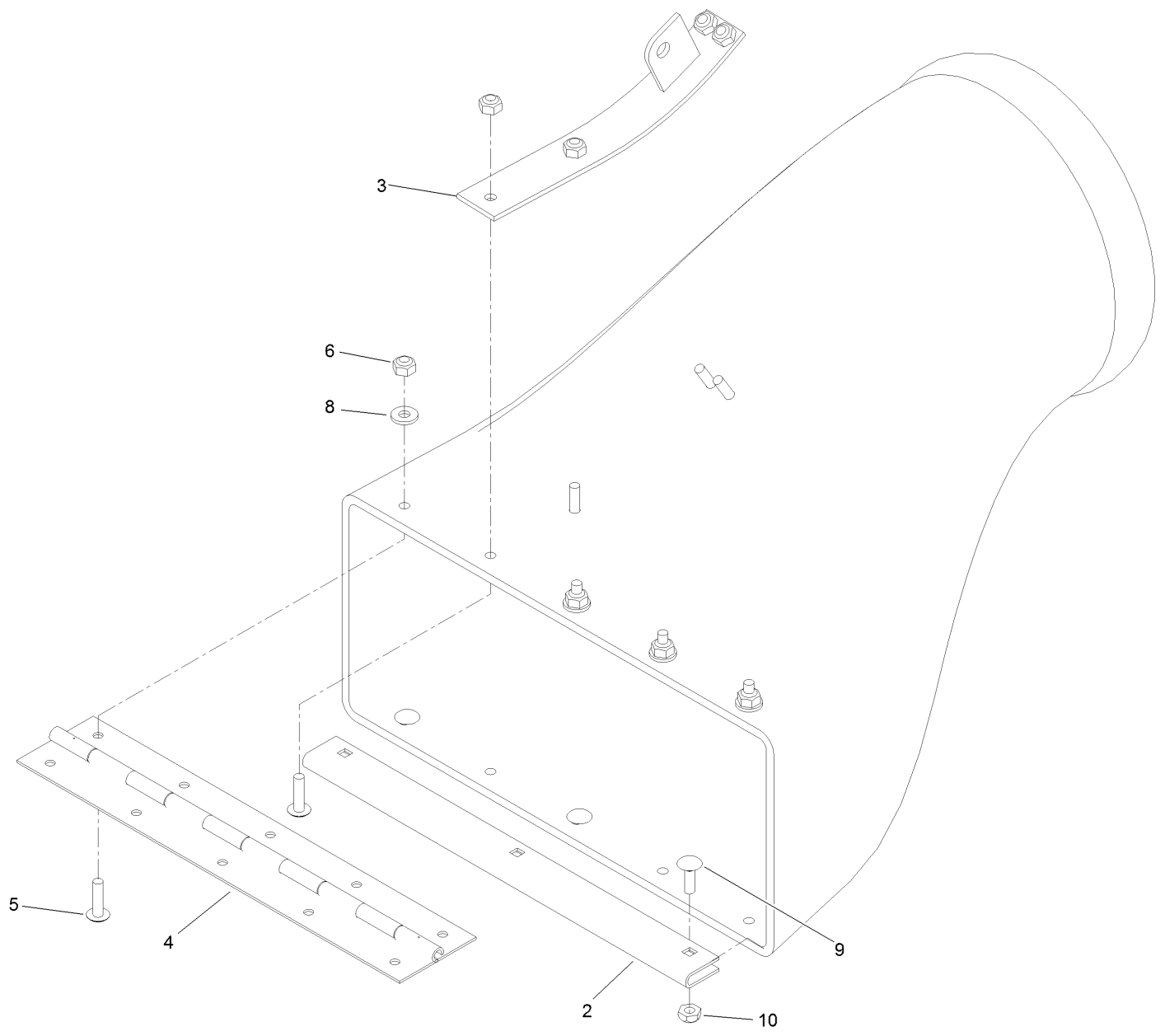

Discharge Tube Assembly No. 103-9487 (continued)

| <i>Ref.</i> | <i>Part Number</i> | <i>Qty.</i> | <i>Description</i> | <i>Ref.</i> | <i>Part Number</i> | <i>Qty.</i> | <i>Description</i> |
|-------------|--------------------|-------------|--------------------|-------------|--------------------|-------------|--------------------|
| 2 | 109-2228-03 | 1 | Guard-Plenum | 6 | 3296-2 | 8 | Nut-Lock, NI |
| 3 | 103-5868-01 | 1 | Mount-Spring | 8 | 3256-14 | 4 | Washer-Flat |
| 4 | 103-4974 | 1 | Hinge-Piano | 9 | 1-807533 | 3 | Bolt-CARR |
| 5 | 1-803075 | 8 | Screw-Head, Truss | 10 | 3296-12 | 3 | Nut-Lock, NI |

Gearbox Assembly No. 103-3387

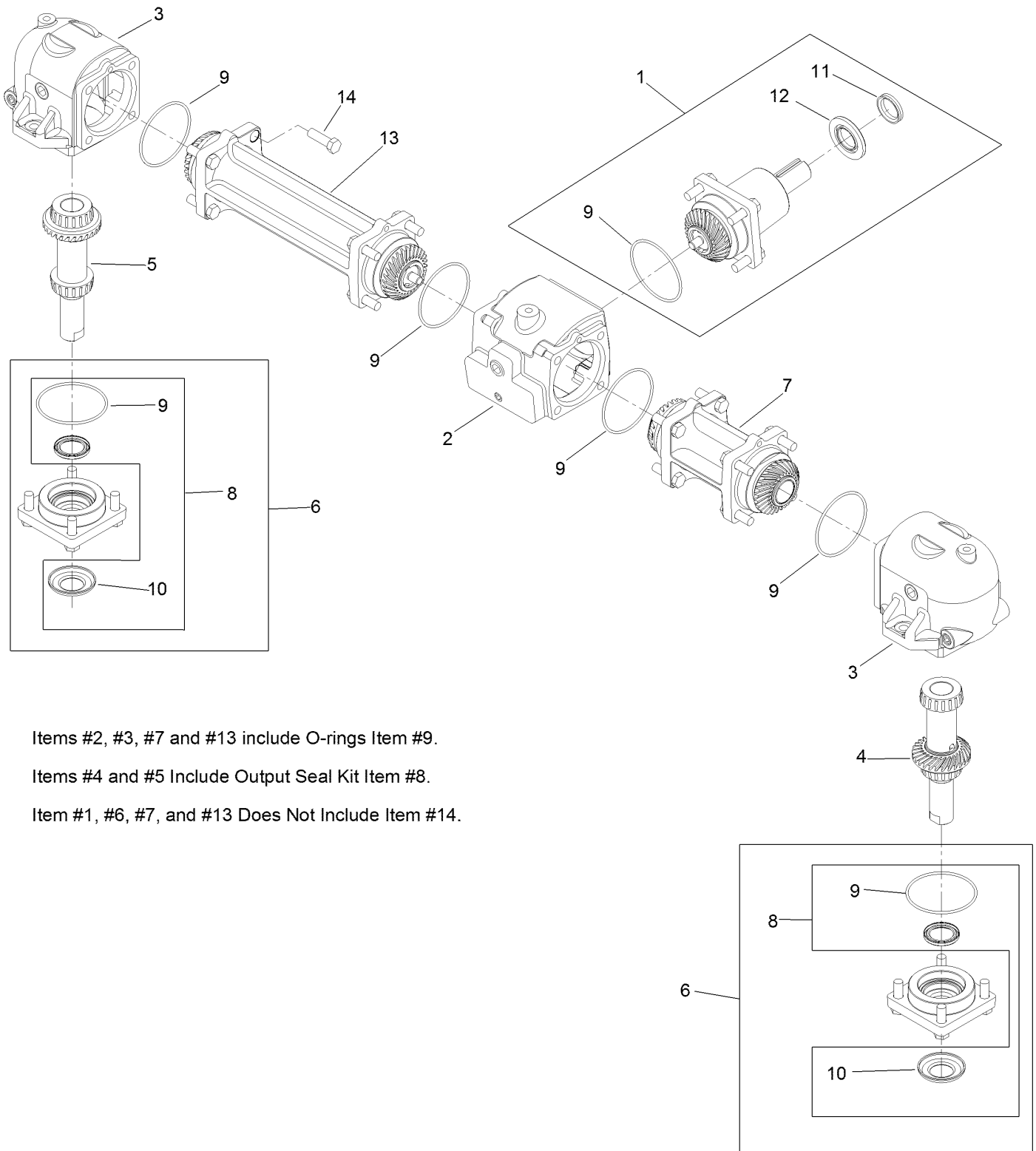

Items #2, #3, #7 and #13 include O-rings Item #9.

Items #4 and #5 Include Output Seal Kit Item #8.

Item #1, #6, #7, and #13 Does Not Include Item #14.

Gearbox Assembly No. 103-3387 (continued)

| <i>Ref.</i> | <i>Part Number</i> | <i>Qty.</i> | <i>Description</i> | <i>Ref.</i> | <i>Part Number</i> | <i>Qty.</i> | <i>Description</i> |
|-------------|--------------------|-------------|--------------------------|-------------|--------------------|-------------|----------------------|
| 1 | 109-0189 | 1 | Pinion-Input | 8 | 109-0201 | 1 | Output Seal Kit |
| 2 | 109-0190 | 1 | Housing-Center | 9 | 109-0203 | 1 | Seal-O-Ring |
| 3 | 109-0191 | 1 | Housing-End | 10 | 109-0204 | 1 | Washer-Cupped |
| 4 | 109-0193 | 1 | Output Shaft And Gear-LH | 11 | 109-0205 | 1 | Seal-V-Ring ● |
| 5 | 109-0195 | 1 | Output Shaft And Gear-RH | 12 | 109-0202 | 1 | Seal-Input ● |
| 6 | 109-0196 | 1 | Cap-Output | 13 | 109-0200 | 1 | Connector-Tube, Long |
| 7 | 109-0198 | 1 | Tube-Connector, Shor | 14 | 93-3987 | 28 | Bolt-Blade |

● Apply bead of Mobil HTS grease (P/N 103-5217 1.5 oz packet) (or a food-grade anti-seize) between input seal and v-ring.

Rear Deck Height Adjustment Assembly No. 109-0323

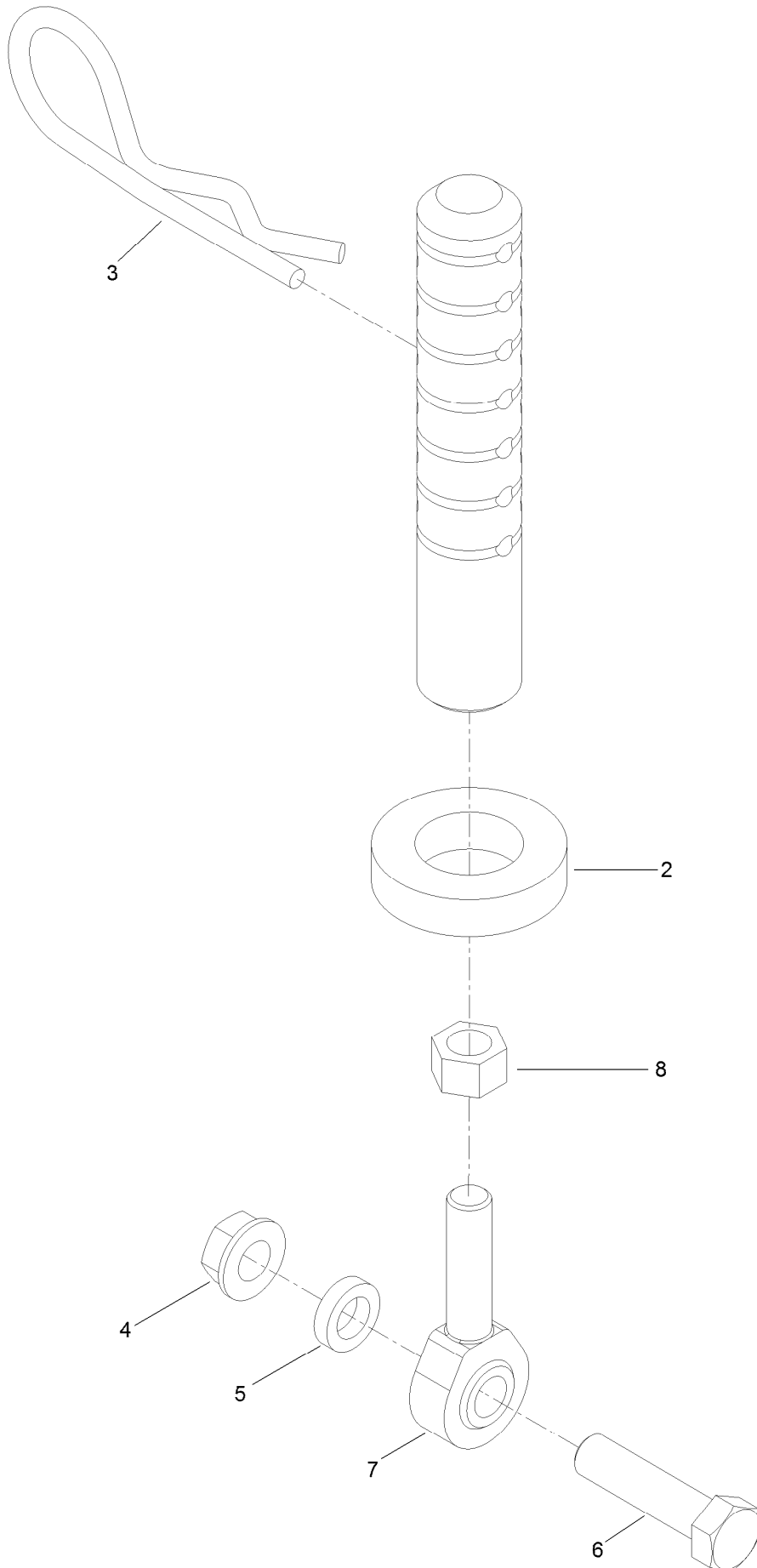

Rear Deck Height Adjustment Assembly No. 109-0323 (continued)

| <i>Ref.</i> | <i>Part Number</i> | <i>Qty.</i> | <i>Description</i> | <i>Ref.</i> | <i>Part Number</i> | <i>Qty.</i> | <i>Description</i> |
|-------------|--------------------|-------------|---------------------|-------------|--------------------|-------------|--------------------|
| 2 | 1-413425 | 1 | Spacer-Deck Support | 6 | 323-8 | 1 | Screw-HH |
| 3 | 103-7353 | 1 | Pin-Cut Height | 7 | 1-613204 | 1 | Balljoint |
| 4 | 3290-357 | 1 | Nut-HHF, Whiz | 8 | 3220-3 | 1 | Nut-HJ |
| 5 | 106-5597 | 1 | Spacer-Idler | | | | |

Deck Support Frame Assembly

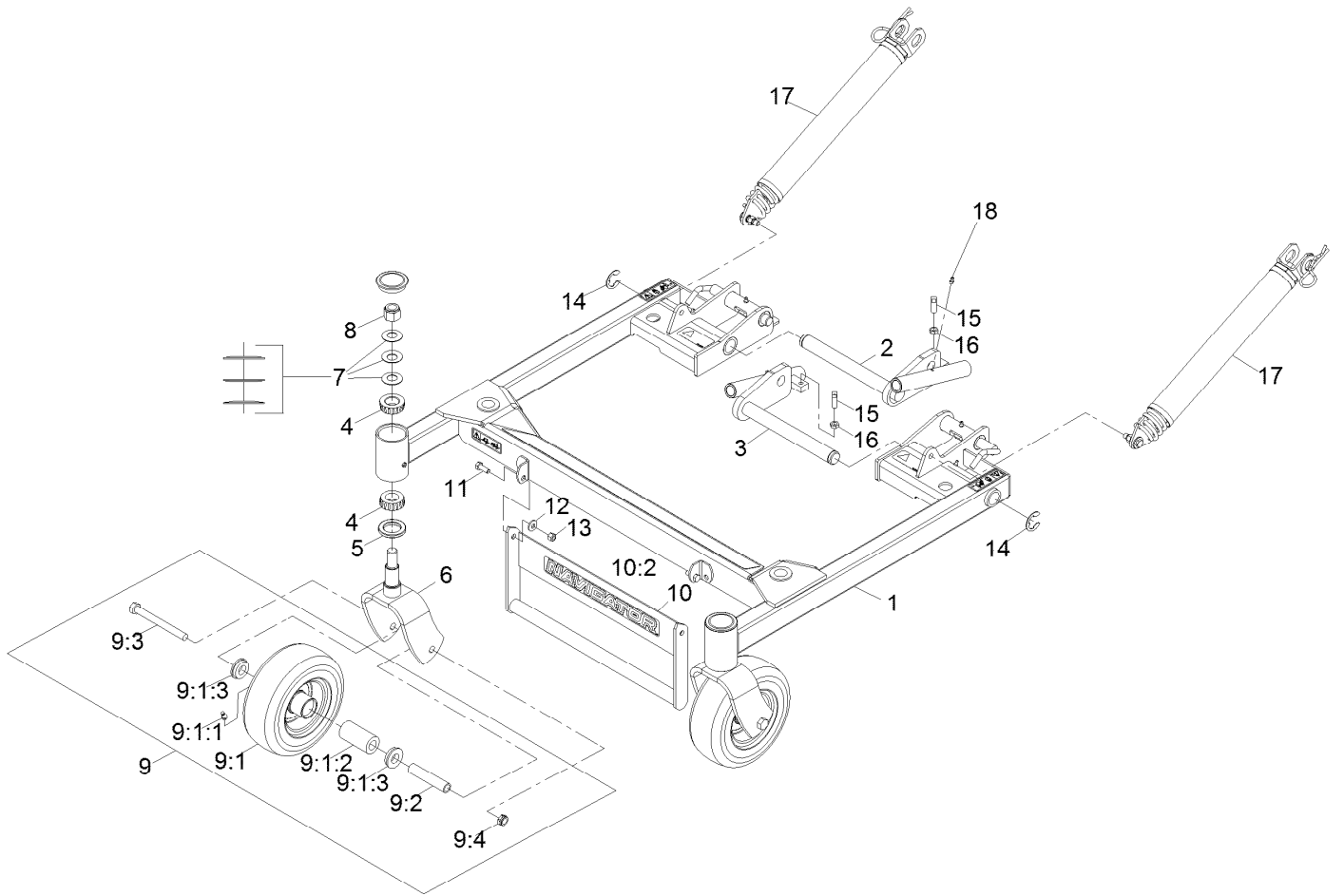

Deck Support Frame Assembly (continued)

| <i>Ref.</i> | <i>Part Number</i> | <i>Qty.</i> | <i>Description</i> | <i>Ref.</i> | <i>Part Number</i> | <i>Qty.</i> | <i>Description</i> |
|-------------|--------------------|-------------|---------------------------------|-------------|--------------------|-------------|-------------------------------|
| 1 | 103-9480 | 1 | Deck Support ASM | 9:2 | 109-2094 | 1 | Spacer-Caster, Front |
| 2 | 103-3729-01 | 1 | Pivot-Deck, RH | 9:3 | 325-19 | 1 | Screw-HH 1/2-13 X 5 |
| 3 | 103-3732-01 | 1 | Pivot-Deck, LH | 9:4 | 3296-45 | 1 | Nut-Nyloc 1/2-13 Thin |
| 4 | 1-543509 | 4 | Cone-Bearing Tapered Roller | 10 | 103-9482 | 1 | Asm, Deck Lift Handle W/Decal |
| 5 | 1-543511 | 2 | Seal-Grease | 10:2 | 126-7199 | 1 | Decal-Navigator Logo |
| 6 | 109-1933-01 | 2 | Fork-Caster | 11 | 322-4 | 2 | Screw-HH 5/16-18 X 7/8 |
| 7 | 1-633508 | 6 | Washer-Spring Disc | 12 | 1-303334 | 2 | Washer-Spring Disc 5/16 |
| 8 | 3296-51 | 2 | Nut-Nyloc 3/4-10 | 13 | 3296-29 | 2 | Nut-Nyloc 5/16-18 |
| 9 | 103-9495 | 2 | Asm, Caster Wheel W/Axle | 14 | 1-808519 | 2 | Ring-Snap |
| 9:1 | 103-4324 | 1 | Asm, Wheel And Tire 8X3.00-4 Sp | 15 | 3243-5 | 2 | Setscrew-SQH 3/8-16 X 1 |
| 9:1:1 | 302-61 | 1 | Zerk-45° 1/4-28 | 16 | 3218-3 | 2 | Nut-Jam 3/8-16 |
| 9:1:2 | 103-4588 | 1 | Bearing-Roller, Straight | 17 | 116-7851 | 2 | Lift Assist Spring ASM |
| 9:1:3 | 1-513810 | 2 | Bushing-Flanged | 18 | 302-19 | 2 | Zerk-1/4-28 Str |

Deck Support W/Decals Assembly No. 103-9480

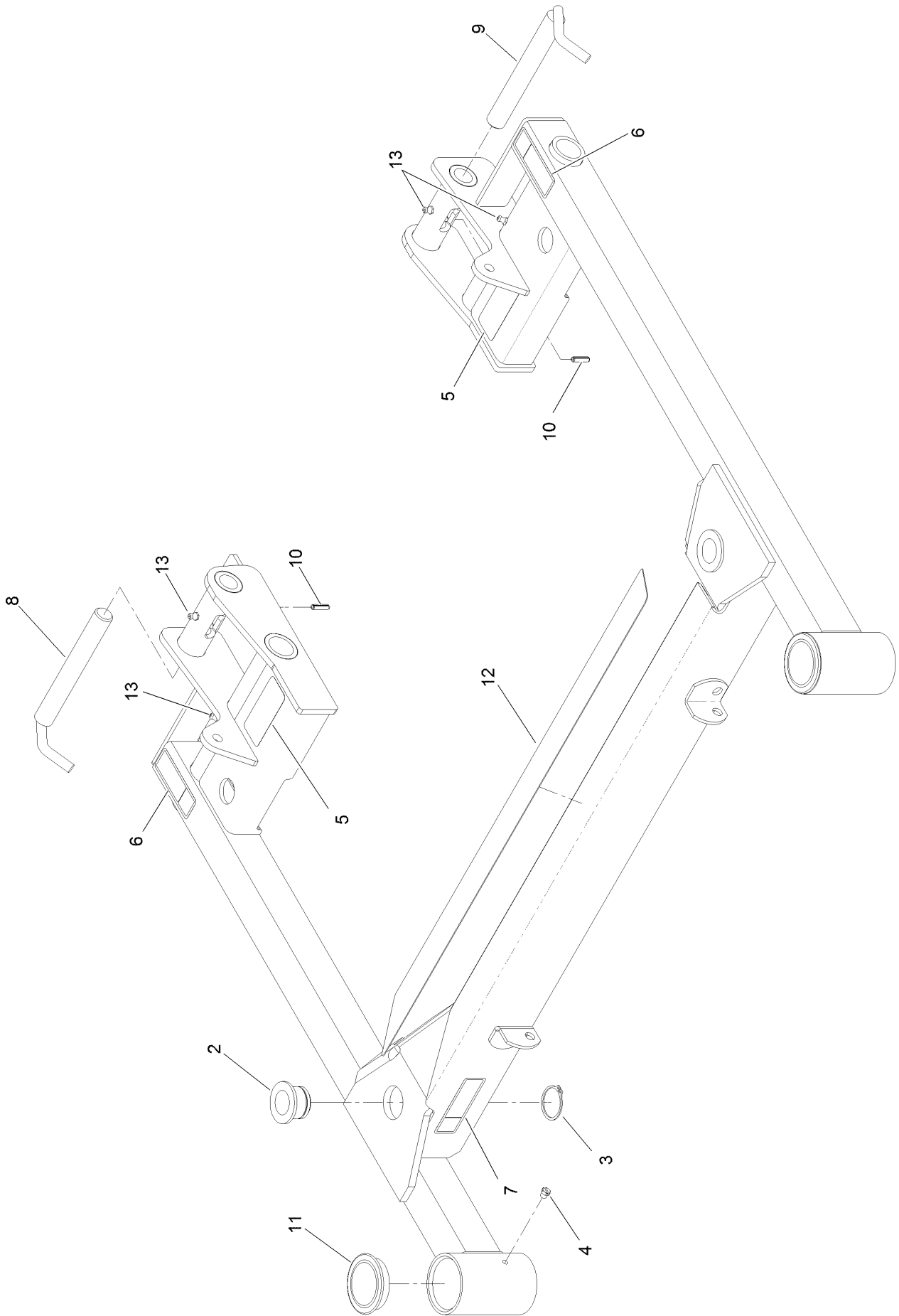

Deck Support W/Decals Assembly No. 103-9480 (continued)

| <i>Ref.</i> | <i>Part Number</i> | <i>Qty.</i> | <i>Description</i> | <i>Ref.</i> | <i>Part Number</i> | <i>Qty.</i> | <i>Description</i> |
|-------------|--------------------|-------------|--------------------------------|-------------|--------------------|-------------|--------------------|
| 2 | 103-7436 | 2 | Bushing-Support, Deck | 8 | 103-4119 | 1 | Lock-Deck, RH |
| 3 | 32120-33 | 2 | Ring-Retaining | 9 | 103-4118 | 1 | Lock-Deck, LH |
| 4 | 1-811010 | 2 | Plug | 10 | 32121-3 | 2 | Pin-Spring |
| 5 | 93-6696 | 2 | Decal-Warning | 11 | 103-4882 | 2 | Cap-Grease |
| 6 | 116-8935 | 2 | Decal-Warning, Folding Deck | 12 | 103-8630 | 1 | Pad-Anti Skid |
| 7 | 116-8936 | 1 | Decal-Danger | 13 | 302-19 | 4 | Fitting-Grease |

Spring Lift Assist Assembly No. 116-7851

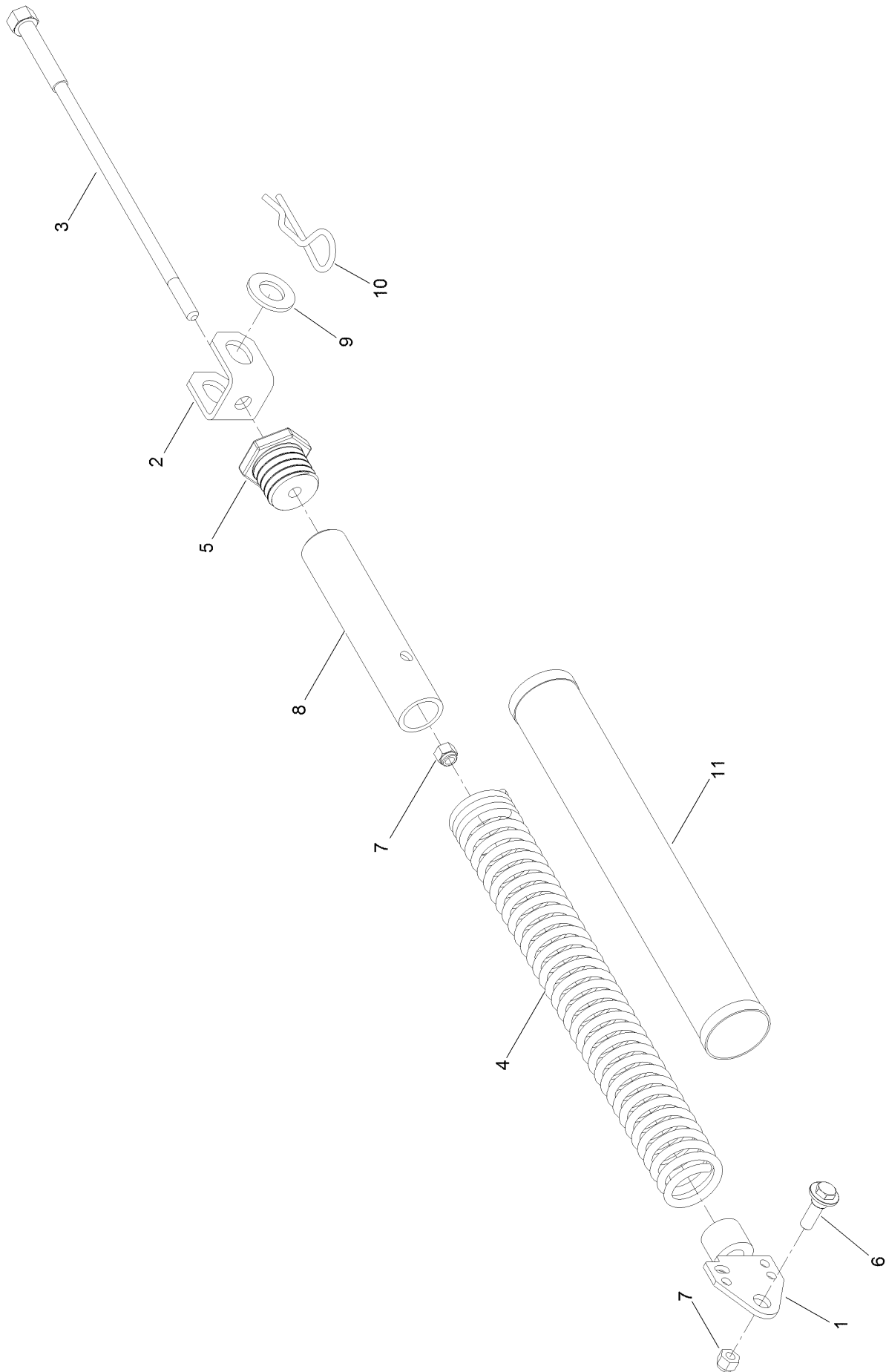

Spring Lift Assist Assembly No. 116-7851 (continued)

| <i>Ref.</i> | <i>Part Number</i> | <i>Qty.</i> | <i>Description</i> | <i>Ref.</i> | <i>Part Number</i> | <i>Qty.</i> | <i>Description</i> |
|-------------|--------------------|-------------|--------------------------|-------------|--------------------|-------------|--------------------|
| 1 | 103-4284 | 1 | Tensioner-Spring | 7 | 3296-39 | 2 | Nut-Lock, NI |
| 2 | 103-4285 | 1 | Mount-Lift Assist, Deck | 8 | 103-7865 | 1 | Spring-Tube |
| 3 | 103-3773 | 1 | Shaft-Adjustment, Spring | 9 | 3256-28 | 1 | Washer-Flat |
| 4 | 103-4281 | 1 | Spring-Extension | 10 | 103-7353 | 1 | Pin-Cut Height |
| 5 | 103-3772 | 1 | Plug-Adjuster, Spring | 11 | 103-7971 | 1 | Cover-Spring, Deck |
| 6 | 614672 | 1 | Bolt-Shoulder | | | | |

Seat and Consoles Assembly

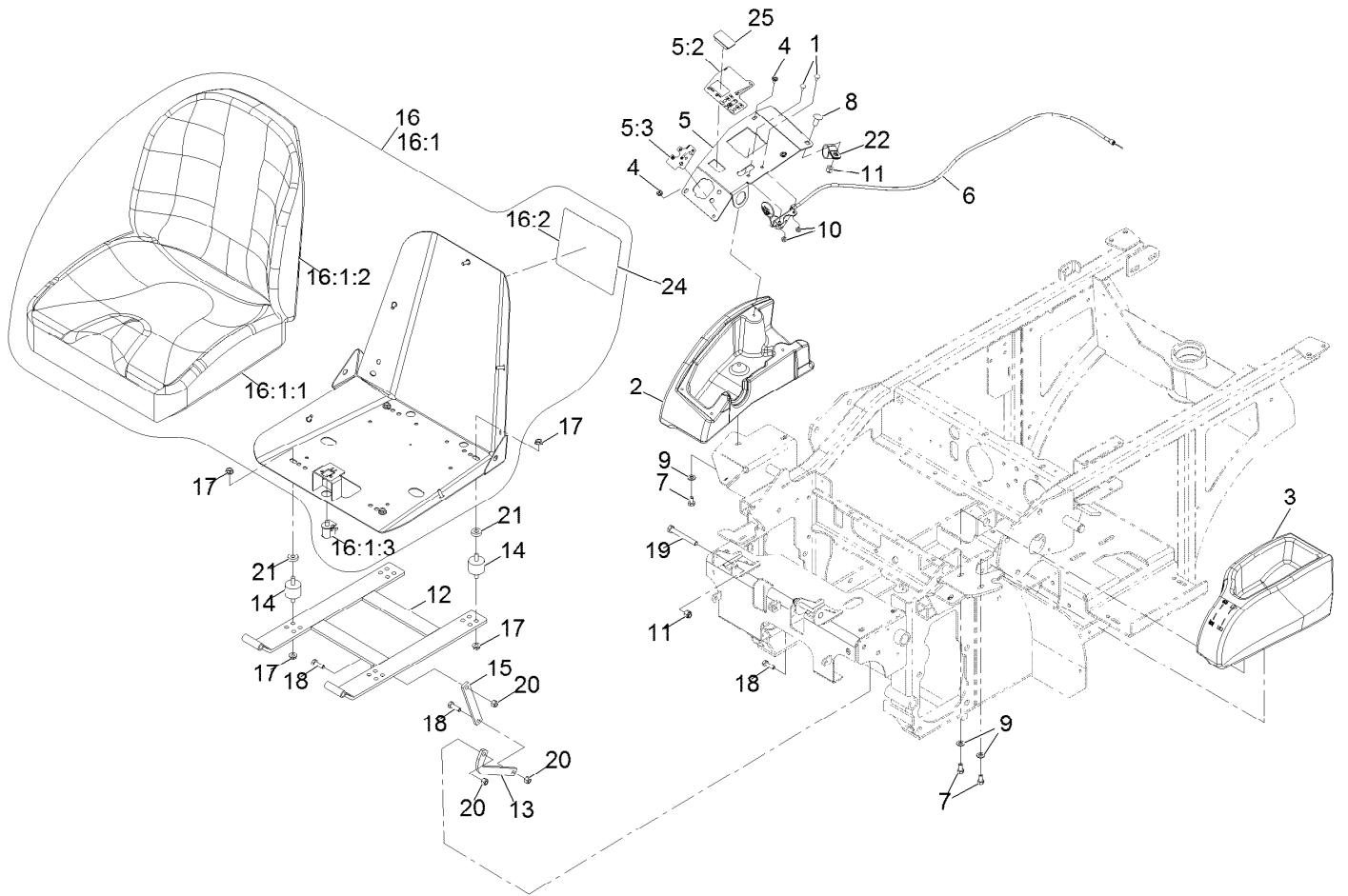

Seat and Consoles Assembly (continued)

| <i>Ref.</i> | <i>Part Number</i> | <i>Qty.</i> | <i>Description</i> | <i>Ref.</i> | <i>Part Number</i> | <i>Qty.</i> | <i>Description</i> |
|-------------|--------------------|-------------|----------------------------|-------------|--------------------|-------------|-------------------------|
| 1 | 1-807513 | 2 | Bolt-Carriage #10-24 X 1/2 | 15 | 103-8563 | 1 | Link-Seat |
| 2 | 116-9430 | 1 | Console-RH | 16 | 116-4849 | 1 | Seat ASM |
| 3 | 126-4342 | 1 | Console, LH Grey | 16:1 | | 1 | Seat ASM ● |
| 4 | 109-2661 | 4 | Screw-PPH #10-24 X 1/2 | 16:1:1 | 116-4848 | 1 | ASM-Seat Bottom Cushion |
| 5 | 116-9373 | 1 | Control Panel ASM | 16:1:2 | 116-3738 | 1 | Cushion,Seat Back |
| 5:2 | 116-9357 | 1 | Decal-Console | 16:1:3 | 82-2190 | 1 | Switch |
| 5:3 | 126-7425 | 1 | Decal-Speed Control | 16:2 | 116-9044 | 1 | Decal-Service Aid |
| 6 | 109-4641 | 1 | Cable-Throttle | 17 | 32128-20 | 8 | Nut-Whizlock 5/16-18 |
| 7 | 322-2 | 6 | Screw-HH 5/16-18 X 5/8 | 18 | 322-5 | 3 | Screw-HH 5/16-18 X 1 |
| 8 | 3231-27 | 1 | Bolt-Carriage 3/8-16 X 7/8 | 19 | 323-14 | 2 | Screw-HH 3/8-16 X 3 |
| 9 | 3256-23 | 6 | Washer-5/16 Sae | 20 | 3296-29 | 3 | Nut-Nyloc 5/16-18 |
| 10 | 3296-2 | 2 | Nut-Nyloc #10-24 | 21 | 5-0652 | 4 | Spacer |
| 11 | 3296-39 | 3 | Nut-Nyloc 3/8-16 | 22 | 1-643312 | 1 | Clip-Loom |
| 12 | 103-4362-03 | 1 | Frame-Seat | 24 | 116-9044 | 1 | Decal-Service Aid |
| 13 | 116-9554 | 1 | Link-Seat Stop | 25 | 99-7420 | 1 | Plug-Hole |
| 14 | 103-5496 | 4 | Mount-Vibration, Rubber | | | | |

● Not serviced separately

Main Frame Assembly

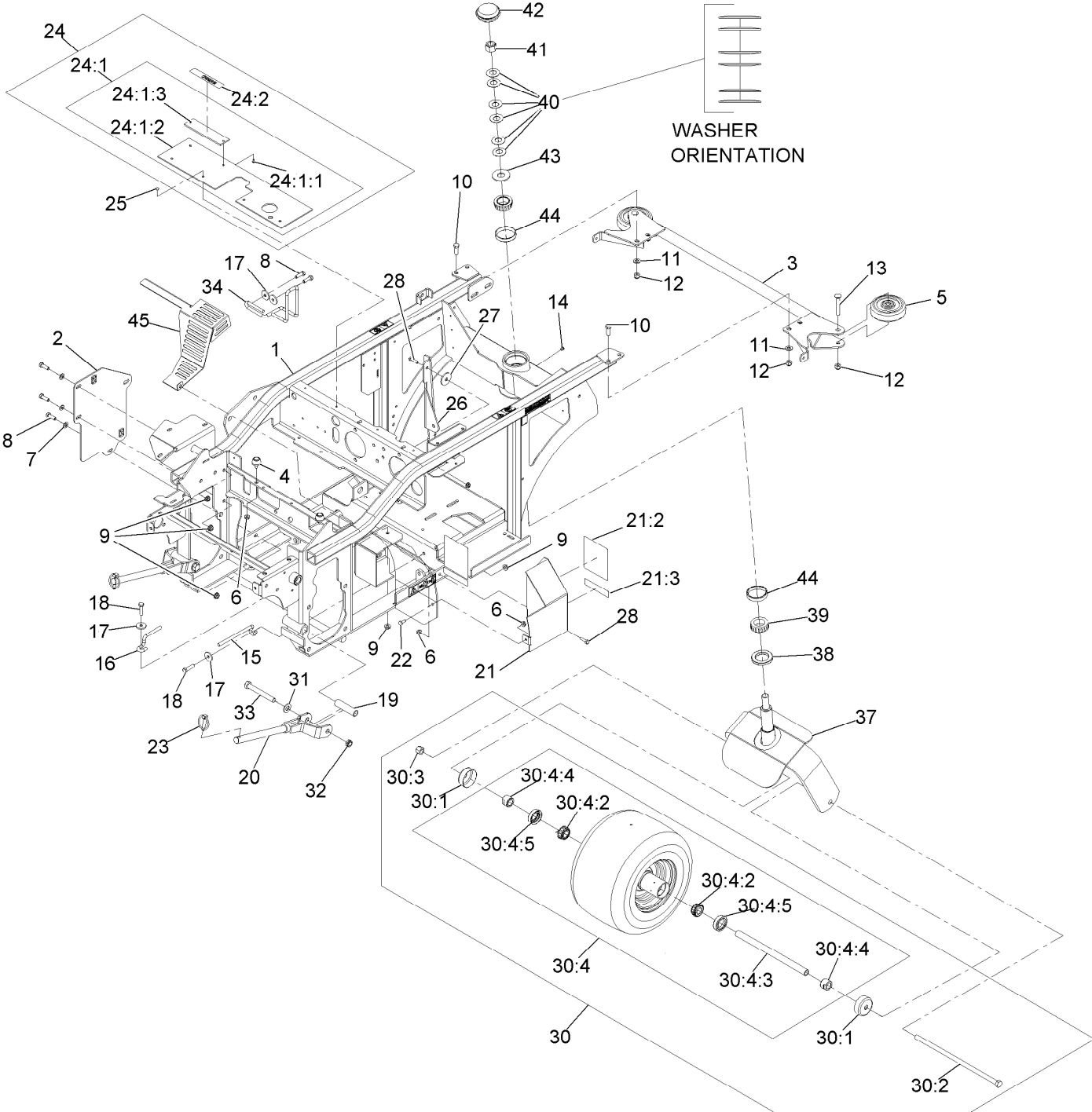

Main Frame Assembly (continued)

| <i>Ref.</i> | <i>Part Number</i> | <i>Qty.</i> | <i>Description</i> | <i>Ref.</i> | <i>Part Number</i> | <i>Qty.</i> | <i>Description</i> |
|-------------|--------------------|-------------|------------------------------|-------------|--------------------|-------------|---|
| 1 | 116-7482 | 1 | Frame ASM | 24:2 | 98-1977 | 1 | Decal-Warning |
| 2 | 116-7396-03 | 1 | Plate-Support | 25 | 1-803035 | 4 | Rivet 3/16 X 1/4 |
| 3 | 109-0925-03 | 1 | Bumper-Rear | 26 | 109-5874-03 | 1 | Brace-PTO |
| 4 | 109-2365 | 1 | Bumper-Rubber | 27 | 1-213069 | 1 | Washer |
| 5 | 103-5408 | 2 | Roller-Bumper | 28 | 321-6 | 2 | Screw-HH 1/4-20 X 1 |
| 6 | 32128-33 | 5 | Nut-Whizlock 1/4-20 | 30 | 103-9494 | 1 | Asm, Rear Caster Wheel W/Axle |
| 7 | 3256-23 | 3 | Washer-5/16 Sae | 30:1 | 103-2768 | 2 | Guard-Seal |
| 8 | 322-5 | 5 | Screw-HH 5/16-18 X 1 | 30:2 | 103-7738 | 1 | Screw-HH 1/2-13 X 13 |
| 9 | 32128-20 | 5 | Nut-Whizlock 5/16-18 | 30:3 | 3296-23 | 1 | Nut-Nyloc 1/2-13 |
| 10 | 323-6 | 4 | Screw-HH 3/8-16 X 1 | 30:4 | 103-5305 | 1 | Asm, Wheel Tire And Brg 13X8.00-6 Sp |
| 11 | 3256-24 | 4 | Washer-3/8 Sae | 30:4:2 | 1-633585 | 2 | Bearing-Cone Tapered Roller |
| 12 | 3296-39 | 6 | Nut-Nyloc 3/8-16 | 30:4:3 | 103-5302 | 1 | Axle-Caster |
| 13 | 3231-31 | 2 | Bolt-Carriage 3/8-16 X 2 1/2 | 30:4:4 | 103-3051 | 2 | Spacer-Nut ■ |
| 14 | 1-811010 | 1 | Plug | 30:4:5 | 103-0063 | 2 | Seal-Double Lip |
| 15 | 103-8333 | 1 | Guide-Belt | 31 | 3256-26 | 2 | Washer-1/2 Sae |
| 16 | 103-8349 | 1 | Guide-Belt | 32 | 3296-45 | 2 | Nut-Nyloc 1/2-13 Thin |
| 17 | 1-613235 | 4 | Washer | 33 | 325-17 | 2 | Screw-HH 1/2-13 X 4 |
| 18 | 322-6 | 2 | Screw-HH 5/16-18 X 1 1/4 | 34 | 116-8323 | 1 | Guide-Belt |
| 19 | 1-633060 | 2 | Spacer-Wheel, Short | 37 | 103-3351-03 | 1 | Fork-Rear Caster |
| 20 | 103-6596-03 | 2 | Rod-Push | 38 | 103-9027 | 1 | Seal-Grease |
| 21 | 130-2879 | 1 | Drive Shield ASM | 39 | 103-9028 | 2 | Cone-Bearing Taper Roller |
| 21:2 | 116-8941 | 1 | Decal-Belt Routing | 40 | 1-633508 | 6 | Washer-Spring Disc |
| 21:3 | 98-1977 | 1 | Decal-Warning | 41 | 3296-51 | 1 | Nut-Nyloc 3/4-10 |
| 22 | 321-3 | 1 | Screw-HH 1/4-20 X 5/8 | 42 | 103-9057 | 1 | Cap-Grease |
| 23 | 103-4155 | 2 | Pin-Lynch | 43 | 3256-8 | 1 | Washer |
| 24 | 103-9476 | 1 | Lift Shield ASM | 44 | 103-9029 | 2 | Cup-Bearing Tapered Roller |
| 24:1 | | 1 | Shield-Lift ● | 45 | 116-7272-03 | 1 | Shield-Heat |
| 24:1:1 | 1-803035 | 2 | Rivet 3/16 X 1/4 | | | | |
| 24:1:2 | 103-8819 | 1 | Flap-Guard | | | | |
| 24:1:3 | 103-9114-03 | 1 | Plate-Decal | | | | |

● Not serviced separately

■ Use Pro-Lock, Nut Type (P/N 1-840022, .5ml tube) on threads.

Parking Brake Assembly

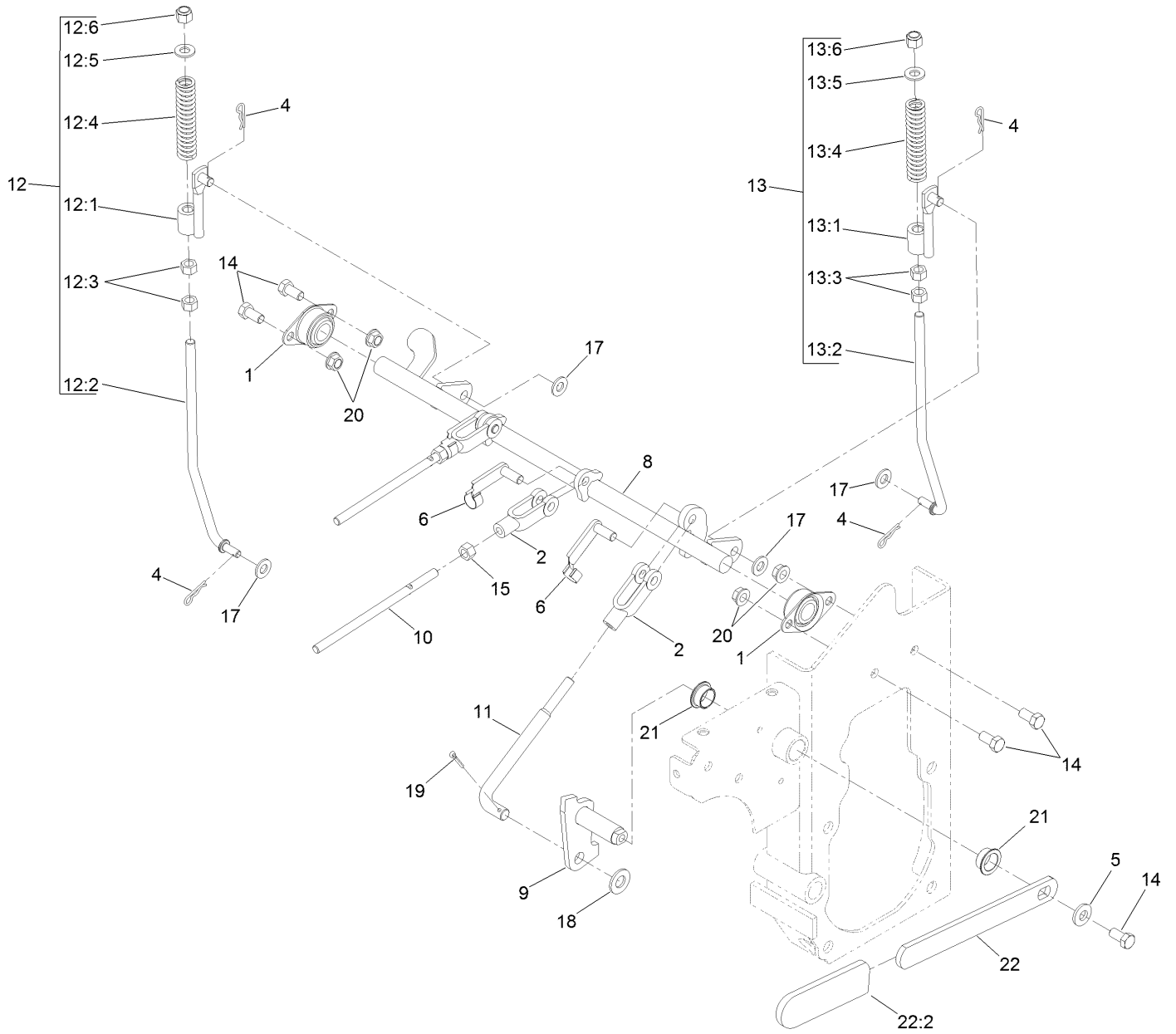

Parking Brake Assembly (continued)

| <i>Ref.</i> | <i>Part Number</i> | <i>Qty.</i> | <i>Description</i> | <i>Ref.</i> | <i>Part Number</i> | <i>Qty.</i> | <i>Description</i> |
|-------------|--------------------|-------------|----------------------|-------------|--------------------|-------------|-----------------------|
| 1 | 1-633102 | 2 | Bearing-Flange, Side | 13 | 116-9749 | 1 | LH Brake Linkage ASM |
| 2 | 1-633131 | 3 | Yoke-Linkage, Brake | 13:1 | 116-8467 | 1 | Brake Linkage ASM |
| 4 | 1-806003 | 4 | Pin-Cotter | 13:2 | 116-8464 | 1 | Link-Brake, LH |
| 5 | 98-5975 | 1 | Washer-Belleville | 13:3 | 3219-3 | 2 | Nut-Hex |
| 6 | 103-2399 | 3 | Pin-Spring, Clevis | 13:4 | 116-8470 | 1 | Spring-Compression |
| 8 | 116-7483-03 | 1 | Shaft-Brake | 13:5 | 3256-24 | 1 | Washer-Flat |
| 9 | 116-7486 | 1 | Pivot-Brake | 13:6 | 3296-6 | 1 | Nut-Lock |
| 10 | 116-7838 | 2 | Rod-Linkage, Brake | 14 | 323-4 | 5 | Screw-HH |
| 11 | 116-8474 | 1 | Rod-Linkage, Brake | 15 | 3219-3 | 2 | Nut-Hex |
| 12 | 116-9748 | 1 | RH Brake Linkage ASM | 17 | 3256-24 | 4 | Washer-Flat |
| 12:1 | 116-8467 | 1 | Brake Linkage ASM | 18 | 3256-26 | 1 | Washer-Flat |
| 12:2 | 116-8465 | 1 | Link-Brake, RH | 19 | 3272-10 | 1 | Pin-Cotter |
| 12:3 | 3219-3 | 2 | Nut-Hex | 20 | 3290-357 | 4 | Nut-HHF, Whiz |
| 12:4 | 116-8470 | 1 | Spring-Compression | 21 | 108519 | 2 | Bushing-Bronze |
| 12:5 | 3256-24 | 1 | Washer-Flat | 22 | 103-9469 | 1 | Park Brake Handle ASM |
| 12:6 | 3296-6 | 1 | Nut-Lock | 22:2 | 1-633268 | 1 | Grip-Lever |

Speed Control Assembly

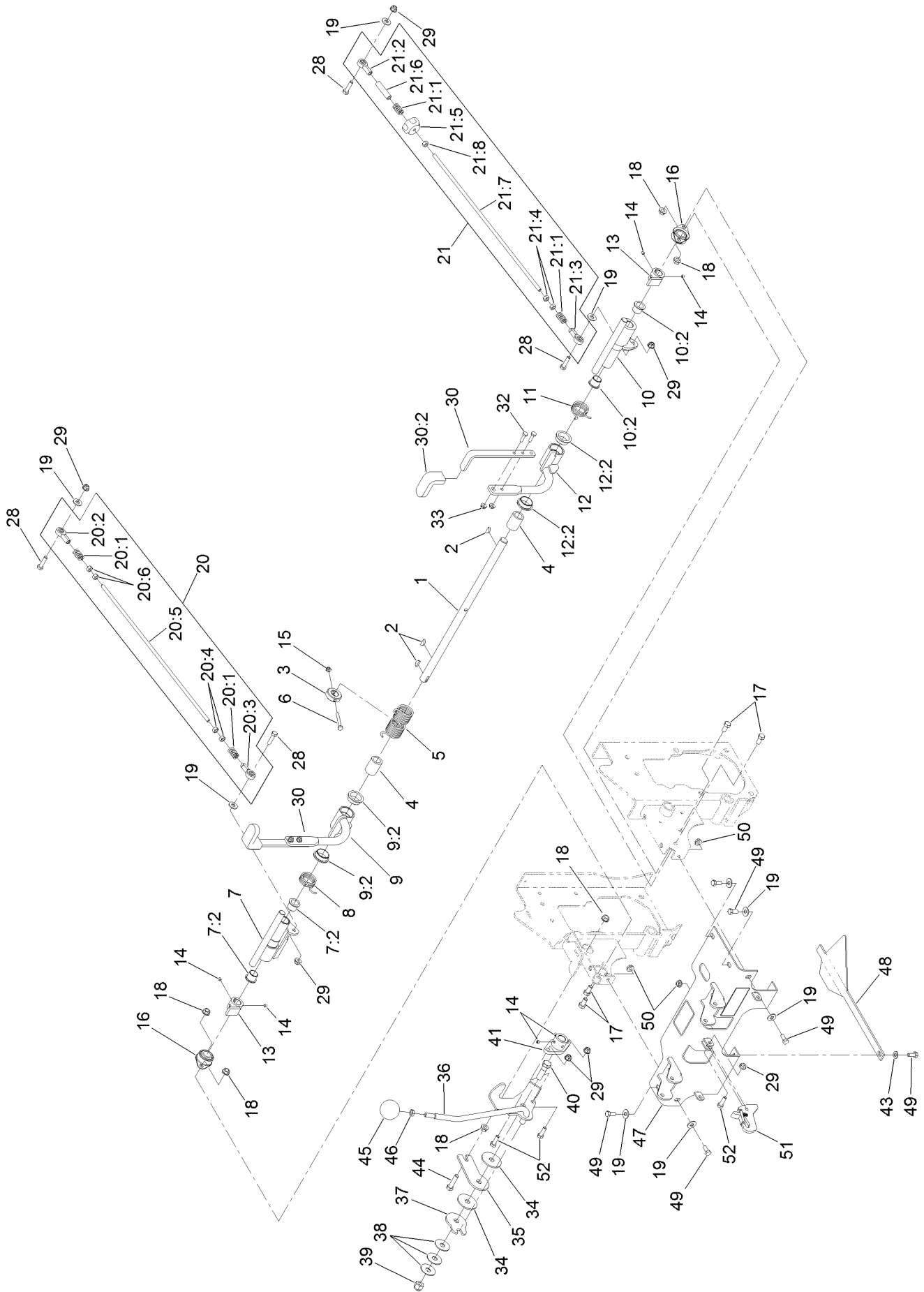

Speed Control Assembly (continued)

| <i>Ref.</i> | <i>Part Number</i> | <i>Qty.</i> | <i>Description</i> | <i>Ref.</i> | <i>Part Number</i> | <i>Qty.</i> | <i>Description</i> |
|-------------|--------------------|-------------|------------------------|-------------|--------------------|-------------|-------------------------------|
| 1 | 116-7856 | 1 | Shaft-Speed Control | 21:3 | 1-633152 | 1 | Balljoint-LH |
| 2 | 3257-5 | 3 | Key-Woodruff | 21:4 | 1-804524 | 2 | Nut |
| 3 | 116-7372 | 1 | Hub-Center Stop | 21:5 | 103-3060 | 1 | Knob-Tracking |
| 4 | 116-7414 | 2 | Bushing-Plastic | 21:6 | 103-5945 | 1 | Spacer |
| 5 | 116-8475 | 1 | Spring-Double Torsion | 21:7 | 116-7492 | 1 | Rod-Steering Linkage |
| 6 | 321-11 | 1 | Screw-HH | 21:8 | 3219-2 | 1 | Nut-Hex |
| 7 | 116-8444 | 1 | RH Control Hub ASM | 28 | 322-6 | 4 | Screw-HH |
| 7:2 | 103-4398 | 2 | Bearing-Flange, Iglide | 29 | 104-8300 | 7 | Nut-Flange, NI |
| 8 | 116-7380 | 1 | Spring-Torsion, RH | 30 | 116-9246 | 2 | Handle ASM |
| 9 | 116-7408 | 1 | RH Steering Handle ASM | 30:2 | 103-5994 | 1 | Grip-Handle, Steering |
| 9:2 | 116-7422 | 2 | Bearing-Flange, Iglide | 32 | 321-5 | 4 | Screw-HH |
| 10 | 116-7416 | 1 | LH Control Hub ASM | 33 | 32128-33 | 4 | Nut-HF |
| 10:2 | 103-4398 | 2 | Bearing-Flange, Iglide | 34 | 103-5009 | 2 | Disc-Friction |
| 11 | 116-7381 | 1 | Spring-Torsion, LH | 35 | 116-7846 | 1 | Plate-Friction, Speed Control |
| 12 | 116-7421 | 1 | LH Steering Handle ASM | 36 | 116-7845 | 1 | Lever-Speed Control |
| 12:2 | 116-7422 | 2 | Bearing-Flange, Iglide | 37 | 116-7849 | 1 | Plate-Friction, Speed Control |
| 13 | 103-4342 | 2 | Hub-Speed Control | 38 | 103-5018 | 3 | Washer-Spring Disc |
| 14 | 108-0989 | 6 | Screw-Set | 39 | 3296-19 | 1 | Nut-Hex |
| 15 | 3296-56 | 1 | Nut-Lock, NI | 40 | 116-7848 | 1 | Screw-HH |
| 16 | 1-633102 | 2 | Bearing-Flange, Side | 41 | 116-7859 | 1 | Hub-Speed Control |
| 17 | 323-4 | 4 | Screw-HH | 43 | 3256-23 | 1 | Washer-Flat |
| 18 | 3290-357 | 6 | Nut-HHF, Whiz | 44 | 323-8 | 1 | Screw-HH |
| 19 | 3256-3 | 9 | Washer-Flat | 45 | 103-4397 | 1 | Knob-Ball, Speed Control |
| 20 | 116-9667 | 1 | RH Pump Linkage ASM | 46 | 3218-3 | 1 | Nut-Jam |
| 20:1 | 1-323245 | 2 | Spring-Compression | 47 | 116-7384 | 1 | Console ASM |
| 20:2 | 1-543017 | 1 | Balljoint-RH | 48 | 103-5993-03 | 1 | Guide-Plenum |
| 20:3 | 1-633152 | 1 | Balljoint-LH | 49 | 322-3 | 6 | Screw-HH |
| 20:4 | 1-804524 | 2 | Nut | 50 | 32128-20 | 3 | Nut-HF |
| 20:5 | 116-7492 | 1 | Rod-Steering Linkage | 51 | 103-8494 | 1 | Hook |
| 20:6 | 3219-2 | 2 | Nut-Hex | 52 | 322-5 | 3 | Screw-HH |
| 21 | 116-9668 | 1 | LH Pump Linkage ASM | | | | |
| 21:1 | 1-323245 | 2 | Spring-Compression | | | | |
| 21:2 | 1-543017 | 1 | Balljoint-RH | | | | |

Fuel Assembly

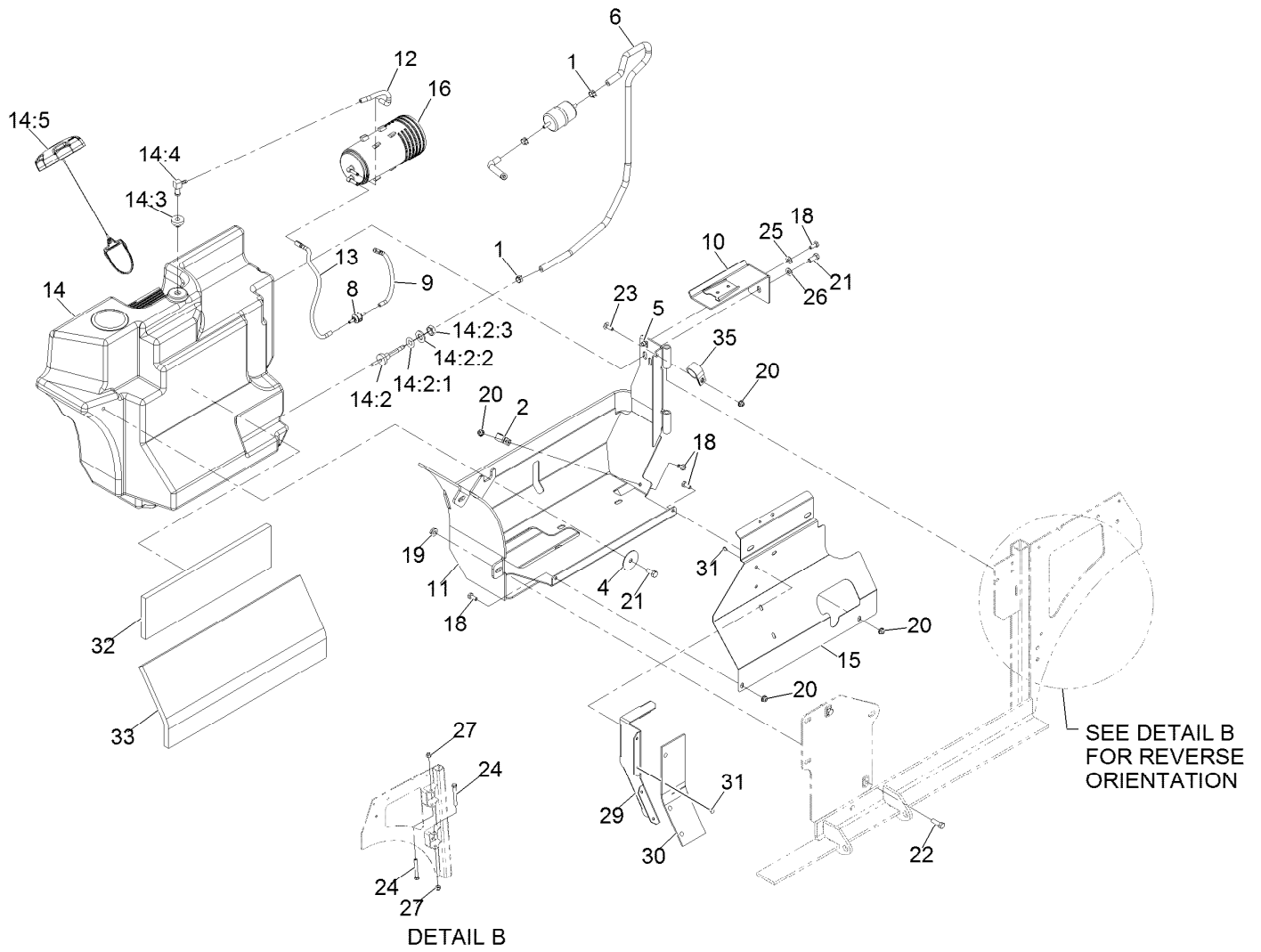

Fuel Assembly (continued)

| <i>Ref.</i> | <i>Part Number</i> | <i>Qty.</i> | <i>Description</i> | <i>Ref.</i> | <i>Part Number</i> | <i>Qty.</i> | <i>Description</i> |
|-------------|--------------------|-------------|-------------------------------------|-------------|--------------------|-------------|----------------------------|
| 1 | 2412-98 | 2 | Clamp-Hose | 14:5 | 120-5461 | 1 | Cap-Fuel, Ratcheting |
| 2 | 1-513762 | 1 | Clip-Loom 1/2 | 15 | 116-7928-03 | 1 | Panel-Tank Shield |
| 4 | 1-653036 | 1 | Washer | 16 | 117-1221 | 1 | Canister-Carbon, 800Cc |
| 5 | 107069 | 1 | Nut-Retainer-Panel 1/4-20 | 18 | 321-3 | 4 | Screw-HH 1/4-20 X 5/8 |
| 6 | 116-5366 | 1 | Fuel Line ASM | 19 | 32128-20 | 2 | Nut-Whizlock 5/16-18 |
| 8 | 115-7868 | 1 | Valve-Check, Vacuum | 20 | 104-7201 | 4 | Nut-Nyloc 1/4-20 Flg |
| 9 | 116-2619 | 1 | Hose-Vent, Formed | 21 | 322-3 | 2 | Screw-HH 5/16-18 X 3/4 ● |
| 10 | 116-2847-03 | 1 | Canister Bracket ASM | 22 | 322-5 | 2 | Screw-HH 5/16-18 X 1 ■ |
| 11 | 116-2848-03 | 1 | Tank Frame ASM | 23 | 3229-1 | 1 | Bolt-Carriage 1/4-20 X 3/4 |
| 12 | 116-2966 | 1 | Hose-Vent, Formed | 24 | 323-14 | 2 | Screw-HH 3/8-16 X 3 |
| 13 | 116-2967 | 1 | Hose-Vent, Formed | 25 | 3256-22 | 1 | Washer-1/4 Sae |
| 14 | 116-8365 | 1 | Fuel Tank ASM | 26 | 3256-23 | 1 | Washer-5/16 Sae |
| 14:2 | 103-6057 | 1 | Fitting-Fuel Bulkhead W/Screen ● | 27 | 3296-39 | 2 | Nut-Nyloc 3/8-16 |
| 14:2:1 | 103-2784 | 1 | O-Ring | 29 | 103-7095-03 | 1 | Deflector-Air |
| 14:2:2 | 3256-26 | 1 | Washer-1/2 Sae | 30 | 103-9658 | 1 | Flap-Rubber |
| 14:2:3 | 3220-5 | 1 | Nut-Jam 1/2-20 | 31 | 1-803035 | 9 | Rivet 3/16 X 1/4 |
| 14:3 | 46-6560 | 1 | Bushing | 32 | 103-7825 | 1 | Insulation-Foam Pad, Front |
| 14:4 | 100-1596 | 1 | Fitting-90 DEG | 33 | 103-7824 | 1 | Insulation-Foam Pad, Rear |
| | | | | 35 | 110-0824 | 1 | R-Clamp |

● Use Pro-Lock, Nut Type (P/N 1-840022, .5ml tube) on threads.

■ Use Pro-Lock retaining type, Part no. 1-840023 (.5cc tube) on threads.

Blower Mounting Assembly

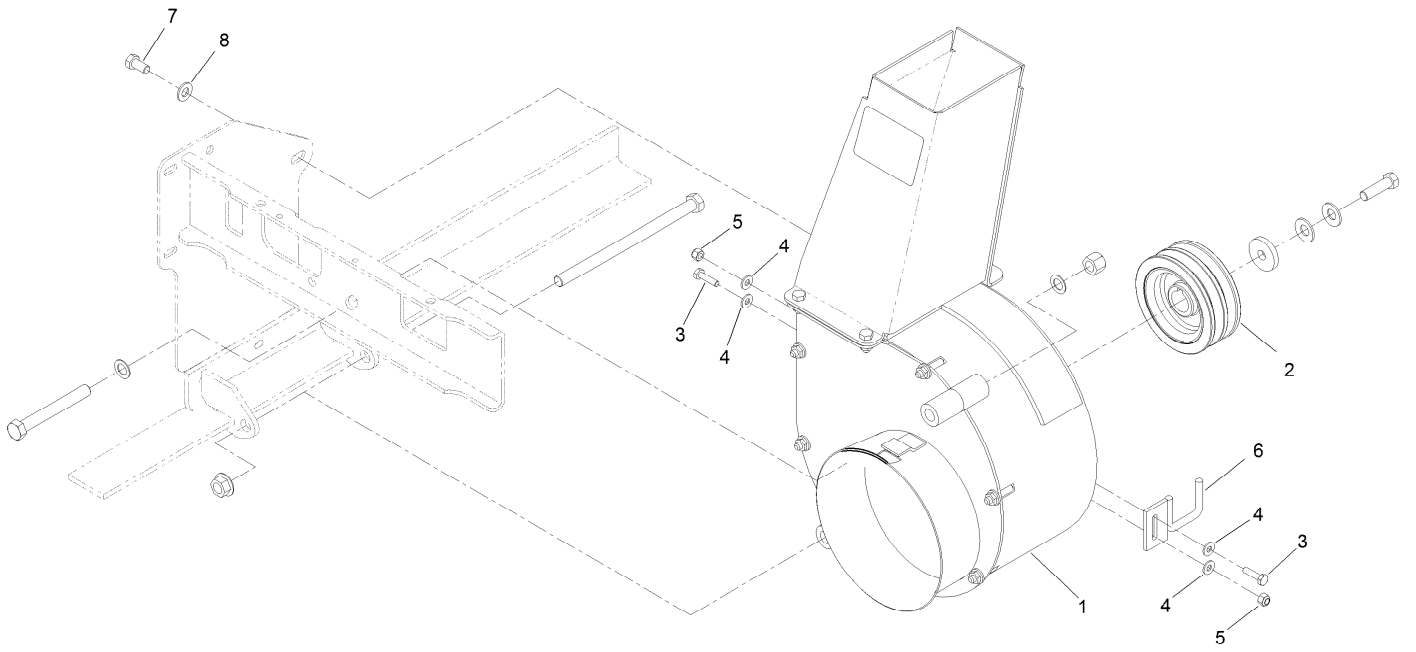

Blower Mounting Assembly (continued)

| <i>Ref.</i> | <i>Part Number</i> | <i>Qty.</i> | <i>Description</i> | <i>Ref.</i> | <i>Part Number</i> | <i>Qty.</i> | <i>Description</i> |
|-------------|--------------------|-------------|--------------------|-------------|--------------------|-------------|--------------------|
| 1 | 116-9649 | 1 | Blower ASM | 5 | 3296-42 | 2 | Nut-Lock, NI |
| 2 | 103-6733 | 1 | Sheave-Blower | 6 | 103-9167-03 | 1 | Guide |
| 3 | 321-6 | 2 | Screw-HH | 7 | 323-4 | 1 | Screw-HH |
| 4 | 3256-22 | 4 | Washer-Flat | 8 | 3256-24 | 1 | Washer-Flat |

Blower Assembly No. 116-9649

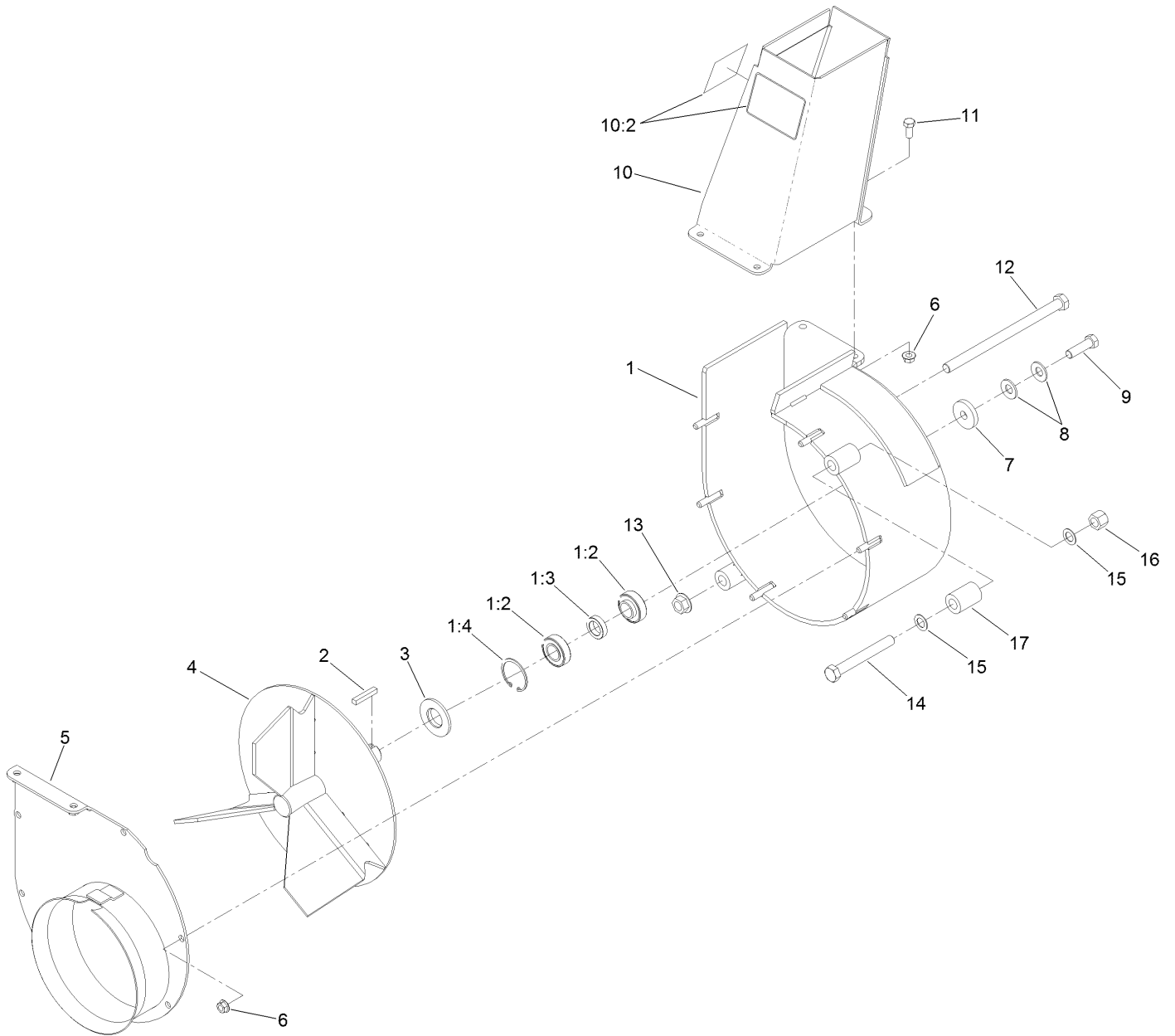

Blower Assembly No. 116-9649 (continued)

| <i>Ref.</i> | <i>Part Number</i> | <i>Qty.</i> | <i>Description</i> | <i>Ref.</i> | <i>Part Number</i> | <i>Qty.</i> | <i>Description</i> |
|-------------|--------------------|-------------|--------------------|-------------|--------------------|-------------|------------------------|
| 1 | 116-9648 | 1 | Housing ASM | 9 | 3212-6 | 1 | Screw-HH |
| 1:2 | 103-3540 | 2 | Bearing-Ball | 10 | 103-9474 | 1 | Discharge Chute ASM |
| 1:3 | 103-4921 | 1 | Spacer-Bearing | 10:2 | 116-8943 | 2 | Decal-Danger, Impeller |
| 1:4 | 32120-8 | 2 | Ring-Snap | 11 | 322-3 | 4 | Screw-HH |
| 2 | 67-7490 | 1 | Key-Square | 12 | 325-42 | 1 | Screw-HH |
| 3 | 103-3894 | 1 | Spacer-Blower | 13 | 32128-23 | 1 | Nut-HF |
| 4 | 103-5194 | 1 | Impeller-3 Blade | 14 | 325-17 | 1 | Screw-HH |
| 5 | 103-3370-03 | 1 | Cover-Blower | 15 | 18-9810 | 2 | Washer-Thrust |
| 6 | 32128-20 | 10 | Nut-HF | 16 | 3296-23 | 1 | Nut-Lock, NI |
| 7 | 1-543610 | 1 | Washer-Clutch | 17 | 103-6999 | 1 | Spacer-Mount |
| 8 | 1-603610 | 2 | Washer-Spring | | | | |

Drive Assembly

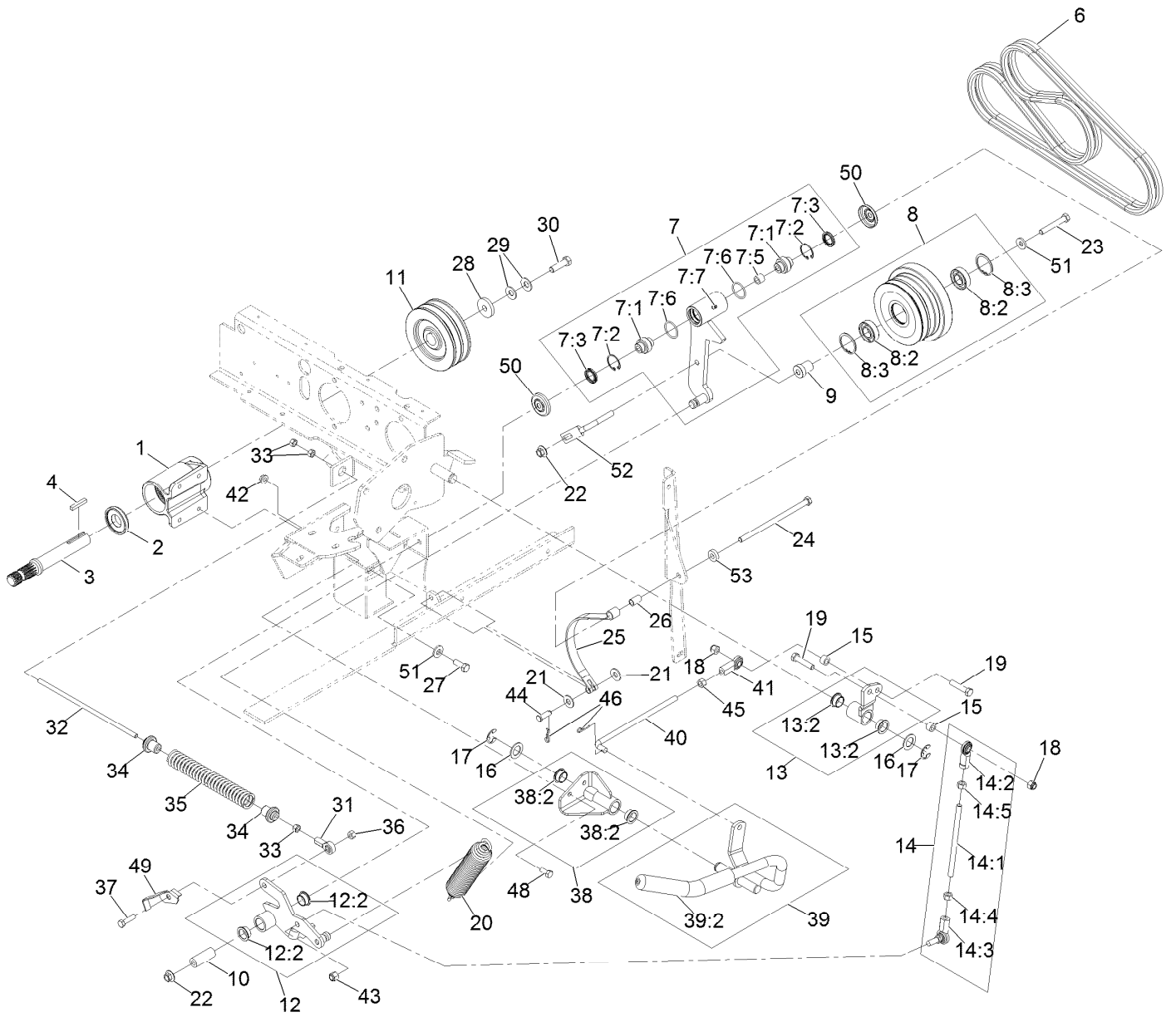

Drive Assembly (continued)

| <i>Ref.</i> | <i>Part Number</i> | <i>Qty.</i> | <i>Description</i> | <i>Ref.</i> | <i>Part Number</i> | <i>Qty.</i> | <i>Description</i> |
|-------------|--------------------|-------------|----------------------|-------------|--------------------|-------------|------------------------|
| 1 | 103-2544 | 1 | Jackshaft ASM | 21 | 3256-4 | 2 | Washer-Flat |
| 2 | 103-2535 | 1 | Spacer-Guard, Bottom | 22 | 32128-19 | 2 | Nut-HF |
| 3 | 103-6735 | 1 | Jackshaft | 23 | 323-12 | 1 | Screw-HH |
| 4 | 67-7490 | 1 | Key-Square | 24 | 323-36 | 1 | Screw-HH |
| 6 | 103-6737 | 1 | Belt, Matched Pair | 25 | 103-7697 | 1 | Band-Brake |
| 7 | 103-8253 | 1 | Idler Pivot ASM | 26 | 103-9816 | 1 | Spacer |
| 7:1 | 103-3504 | 2 | Bearing-Spherical | 27 | 323-6 | 4 | Screw-HH |
| 7:2 | 32120-10 | 2 | Ring-Snap | 28 | 1-543610 | 1 | Washer-Clutch |
| 7:3 | 103-3506 | 2 | Seal-Lip, Single | 29 | 1-603610 | 2 | Washer-Spring |
| 7:5 | 1-413088 | 1 | Bushing-Lever, Lift | 30 | 3212-6 | 1 | Screw-HH |
| 7:6 | 106-7159 | 2 | O-Ring | 31 | 1-543017 | 1 | Balljoint-RH |
| 7:7 | 302-19 | 1 | Fitting-Grease | 32 | 103-7996 | 1 | Linkage-Rod, PTO Brake |
| 8 | 103-9439 | 1 | Idler Sheave ASM | 33 | 3219-2 | 3 | Nut-Hex |
| 8:2 | 251-347 | 2 | Bearing-Ball | 34 | 103-8254 | 2 | Bushing-Spring |
| 8:3 | 32151-13 | 2 | Ring-Retaining | 35 | 103-7997 | 1 | Spring-Brake |
| 9 | 103-7350 | 1 | Spacer-Idler | 36 | 3296-29 | 1 | Nut-Lock, NI |
| 10 | 103-7382 | 1 | Bushing | 37 | 322-6 | 1 | Screw-HH |
| 11 | 103-6732 | 1 | Sheave | 38 | 103-9295 | 1 | Pivot ASM |
| 12 | 103-9296 | 1 | Arm ASM | 38:2 | 108519 | 2 | Bushing-Bronze |
| 12:2 | 108519 | 2 | Bushing-Bronze | 39 | 103-9486 | 1 | PTO Handle ASM |
| 13 | 103-9297 | 1 | Arm ASM | 39:2 | 103-8153 | 1 | Grip-Lever, Control |
| 13:2 | 108519 | 2 | Bushing-Bronze | 40 | 103-8277 | 1 | Link-Handle |
| 14 | 103-7392 | 1 | Clutch Link ASM | 41 | 103-0608 | 1 | Joint-Ball, End |
| 14:1 | 103-7393 | 1 | Rod-Linkage | 42 | 32128-20 | 2 | Nut-HF |
| 14:2 | 103-1167 | 1 | Joint-Ball End, LH | 43 | 3296-6 | 1 | Nut-Lock |
| 14:3 | 103-7994 | 1 | Balljoint-RH | 44 | 283-2 | 1 | Pin-Clevis |
| 14:4 | 3219-3 | 1 | Nut-Hex | 45 | 3219-3 | 1 | Nut-Hex |
| 14:5 | 3219-20 | 1 | Nut-Hex, LH | 46 | 1-806003 | 2 | Pin-Cotter |
| 15 | 92-9025 | 2 | Spacer | 48 | 322-3 | 2 | Screw-HH |
| 16 | 1-303007 | 2 | Washer | 49 | 103-8716-03 | 1 | Switch-Flag |
| 17 | 32151-48 | 2 | E-Ring | 50 | 103-2916 | 2 | Guard-Top |
| 18 | 3296-39 | 2 | Nut-Lock, NI | 51 | 98-5975 | 5 | Washer-Belleville |
| 19 | 323-9 | 2 | Screw-HH | 52 | 109-5491 | 1 | Guide-Belt |
| 20 | 109-0148 | 1 | Spring-Extension | 53 | 5-0652 | 1 | Spacer |

Engine Assembly

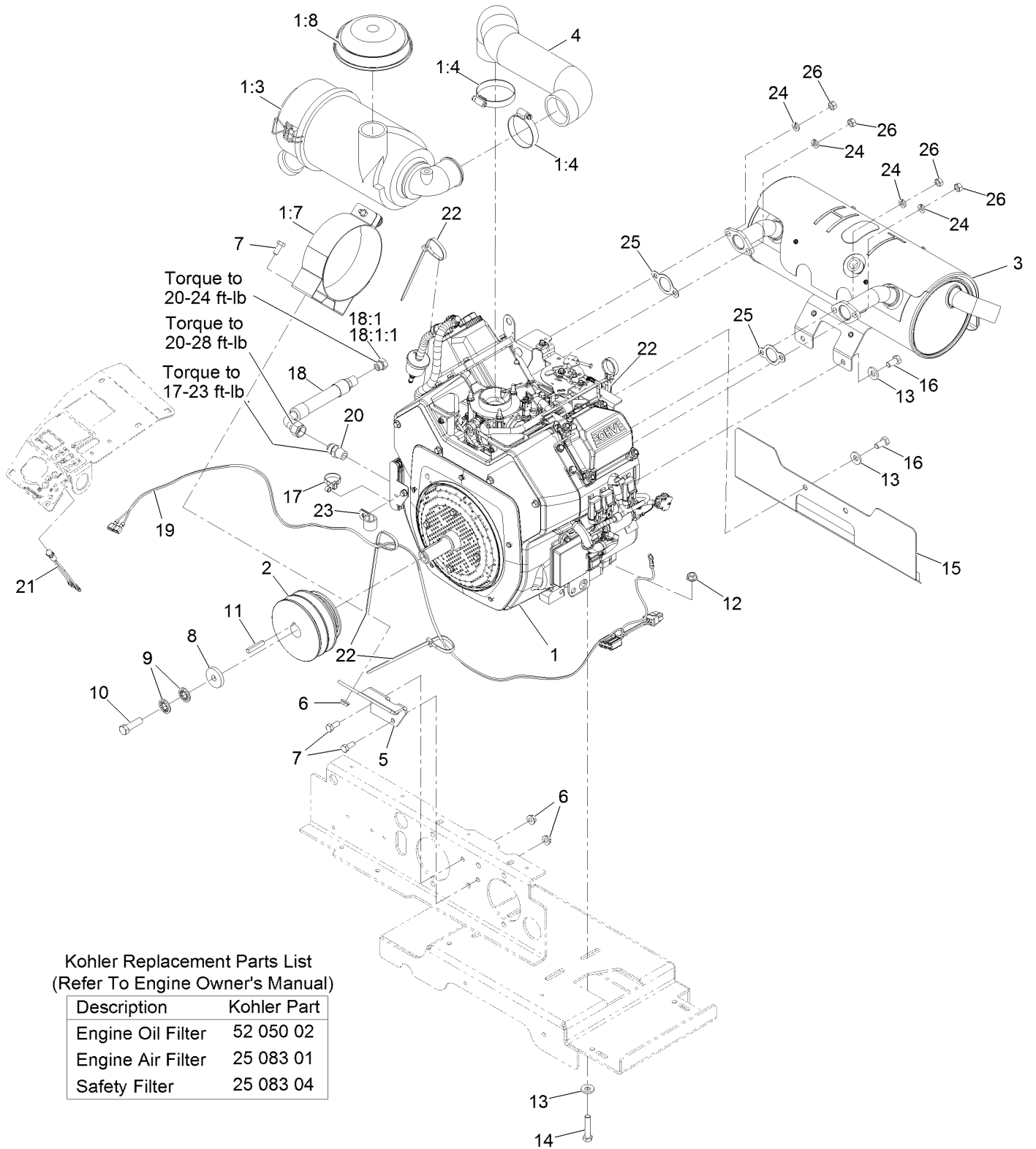

Kohler Replacement Parts List
(Refer To Engine Owner's Manual)

| Description | Kohler Part |
|-------------------|-------------|
| Engine Oil Filter | 52 050 02 |
| Engine Air Filter | 25 083 01 |
| Safety Filter | 25 083 04 |

Engine Assembly (continued)

| <i>Ref.</i> | <i>Part Number</i> | <i>Qty.</i> | <i>Description</i> | <i>Ref.</i> | <i>Part Number</i> | <i>Qty.</i> | <i>Description</i> |
|-------------|--------------------|-------------|----------------------------------|-------------|--------------------|-------------|-------------------------------|
| 1 | | 1 | Engine-Kohler, Ech730-3064 ●■ | 12 | 3290-357 | 4 | Nut-Whizlock 3/8-16 |
| 1:3 | 103-8569 | 1 | Air Cleaner Canister ASM | 13 | 98-5975 | 8 | Washer-Spring Disc 3/8 |
| 1:4 | 2412-42 | 2 | Clamp-Hose | 14 | 323-9 | 4 | Screw-HH 3/8-16 X 1 3/4 |
| 1:7 | 103-1058 | 1 | Bracket-Filter, Air | 15 | 109-0181-03 | 1 | Shield-Exhaust |
| 1:8 | 100-2436 | 1 | Asm-Hood Air Intake W/Clamp | 16 | 323-4 | 4 | Screw-HH 3/8-16 X 3/4 |
| 2 | 103-6731 | 1 | Sheave-Engine | 17 | 109-7896 | 1 | Tie-Cable |
| 3 | 116-3961 | 1 | Muffler | 18 | 116-5338 | 1 | Oil Drain Hose ASM |
| 4 | 116-4016 | 1 | Hose-Air Intake | 18:1 | 353-508 | 1 | Plug-W/O-Ring |
| 5 | 103-3695-03 | 1 | Bracket-Air Filter | 18:1:1 | 237-42 | 1 | O-Ring |
| 6 | 32128-20 | 4 | Nut-Whizlock 5/16-18 | 19 | 116-4543 | 1 | Harness-Light Indicator (Efi) |
| 7 | 322-3 | 4 | Screw-HH 5/16-18 X 3/4 | 20 | 116-1455 | 1 | Fitting-Straight ▲ |
| 8 | 1-543610 | 1 | Washer | 21 | 1-643267 | 1 | Indicator-Red Led |
| 9 | 1-603610 | 2 | Washer-Spring Disc 7/16 | 22 | 1-303335 | 4 | Tie-Cable 7 15/16 (Large) |
| 10 | 3212-6 | 1 | Screw-HH 7/16-20 X 1 1/2 ◆ | 23 | 1-633396 | 1 | Clip-Loom 5/8 |
| 11 | 67-7490 | 1 | Key-Machine 1/4 X 1/4 X 1 1/2 | 24 | 1-805005 | 4 | Washer-Lock 5/16 Heavy |
| | | | | 25 | 1-653291 | 2 | Gasket-Exhaust |
| | | | | 26 | 33014-00 | 4 | Nut-Hex M8-1.25 |

● Not serviced separately

▲ Use a Teflon Pipe Sealant or equivalent on threads.

◆ Use Pro-Lock, Nut Type (P/N 1-840022, .5ml tube) on threads.

■ Obtain parts from www.kohlerplus.com

Hydraulic Assembly (continued)

| <i>Ref.</i> | <i>Part Number</i> | <i>Qty.</i> | <i>Description</i> | <i>Ref.</i> | <i>Part Number</i> | <i>Qty.</i> | <i>Description</i> |
|-------------|--------------------|-------------|------------------------------|-------------|--------------------|-------------|---------------------------|
| 1 | 1-603990 | 8 | Adapter-Straight | 28 | 323-4 | 2 | Screw-HH 3/8-16 X 3/4 |
| 1:1 | 1-603920 | 1 | O-Ring-Sae #8 | 29 | 116-7836 | 2 | 12Cc Hydro Pump ASM |
| 1:2 | 1-603992 | 1 | O-Ring-37 Flare #8 | 30 | 116-5634 | 2 | Tire And Wheel ASM |
| 2 | 1-632208 | 2 | Arm-Control, Pump | 31 | 116-7831 | 1 | Hydraulic Hose ASM |
| 3 | 120-6474 | 2 | Screw-Set, SQH 5/16-18 X 3/4 | 32 | 103-2156 | 5 | Adapter-Straight |
| 4 | 104-7836 | 1 | Filter-Head | 32:1 | 1-603921 | 1 | O-Ring-Sae #6 |
| 5 | 109-4180 | 1 | Element, Oil Filter | 32:2 | 103-1020 | 1 | O-Ring-37 Flare #6 |
| 6 | 116-9274 | 1 | Reservoir ASM | 34 | 3290-357 | 2 | Nut-Whizlock 3/8-16 |
| 6:1 | | 1 | Reservoir-HYD ● | 35 | 126-4400 | 1 | Hydraulic Hose ASM |
| 6:1:1 | 116-9273 | 1 | Reservoir Cap ASM | 36 | 116-7827 | 1 | Hydraulic Hose ASM |
| 6:1:2 | 103-1949 | 1 | Gasket-Cap | 37 | 116-7828 | 1 | Hydraulic Hose ASM |
| 6:2 | 115-4212 | 1 | Decal-Warning | 38 | 116-7829 | 1 | Hydraulic Hose ASM |
| 7 | 103-4246 | 2 | Sheave | 39 | 116-7830 | 1 | Hydraulic Hose ASM |
| 8 | 1-633396 | 1 | Clip-Loom 5/8 | 40 | 109-1264 | 1 | Hydraulic Hose ASM |
| 9 | 103-7706 | 1 | Grommet | 41 | 103-5469 | 1 | Adapter-Tee Special |
| 10 | 1-543286 | 2 | Grommet | 41:1 | 237-42 | 1 | O-Ring |
| 12 | 1-803310 | 4 | Setscrew-5/16-18 X 3/8 | 42 | 103-1828 | 1 | Adapter-Running Tee |
| 13 | 116-7401 | 1 | Motor-HYD, LH | 42:1 | 237-42 | 1 | O-Ring |
| 14 | 116-7402 | 1 | Motor-HYD, RH | 43 | 103-1988 | 7 | Clamp-Hose 11/16 |
| 15 | 354-134 | 2 | Fitting-HYD, 90 DEG | 44 | 103-5452 | 1 | Hose-HYD |
| 15:1 | 237-79 | 1 | O-Ring | 45 | 103-5477 | 1 | Hose-HYD |
| 16 | 325-19 | 8 | Screw-HH 1/2-13 X 5 | 46 | 100-4887 | 1 | Fitting-Barbed, 90 DEG |
| 17 | 32128-49 | 8 | Nut-Whizlock 1/2-13 | 46:1 | 237-42 | 1 | O-Ring |
| 18 | 242-50 | 8 | Nut-Lug 1/2-20 | 48 | 103-7349 | 1 | Short Idler ASM |
| 19 | 1-807272 | 2 | Key-5Mm X 5Mm X 25Mm | 49 | 103-2916 | 1 | Guard-Top |
| 20 | 323-7 | 4 | Screw-HH 3/8-16 X 1 1/4 | 50 | 116-6361 | 2 | Pulley |
| 21 | 32128-43 | 7 | Nut-Whizlock 3/8-16 | 51 | 106-5574 | 1 | Spacer-Mounting, Steering |
| 22 | 1-805004 | 2 | Washer-Lock 1/4 Heavy | 52 | 1-653331 | 1 | Spring |
| 23 | 321-3 | 2 | Screw-HH 1/4-20 X 5/8 | 53 | 323-20 | 1 | Screw-HH 3/8-16 X 3-1/4 |
| 24 | 3256-22 | 2 | Washer-1/4 Sae | 54 | 323-12 | 1 | Screw-HH 3/8-16 X 2 1/2 |
| 25 | 321-6 | 2 | Screw-HH 1/4-20 X 1 | 55 | 323-9 | 1 | Screw-HH 3/8-16 X 1 3/4 |
| 26 | 32128-33 | 2 | Nut-Whizlock 1/4-20 | 56 | 3256-24 | 2 | Washer-3/8 Sae |
| 27 | 103-8631 | 1 | Bracket-Clamp | 58 | 103-4244 | 1 | Belt |

● Not serviced separately

Hydraulic Pump Assembly No. 116-7836

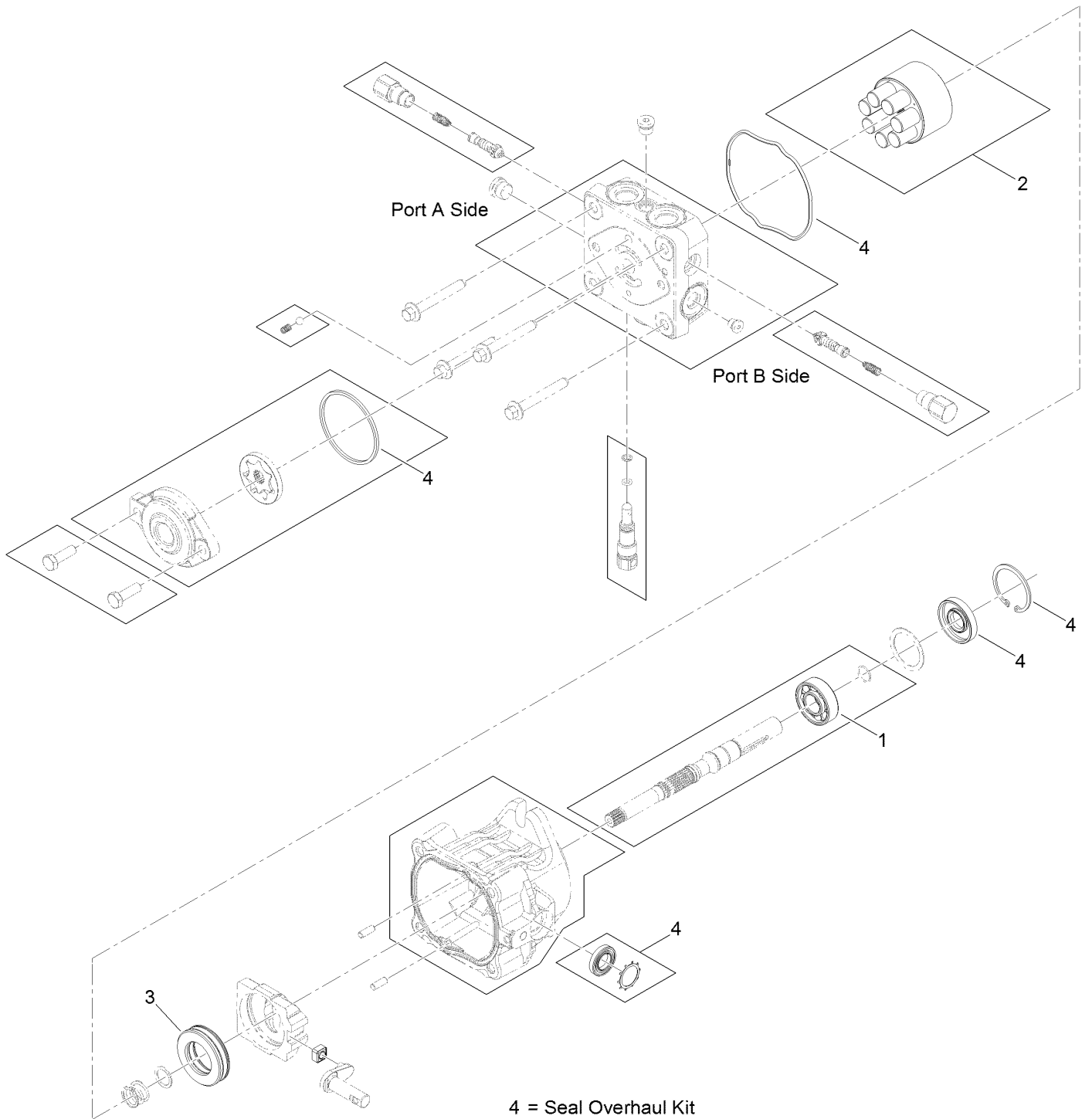

Hydraulic Pump Assembly No. 116-7836 (continued)

| <i>Ref.</i> | <i>Part Number</i> | <i>Qty.</i> | <i>Description</i> |
|-------------|--------------------|-------------|--------------------|
| 1 | 104-5311 | 1 | Bearing-Ball |
| 2 | 103-7443 | 1 | Cylinder Block Kit |

| <i>Ref.</i> | <i>Part Number</i> | <i>Qty.</i> | <i>Description</i> |
|-------------|--------------------|-------------|---------------------------------|
| 3 | 121-3235 | 1 | Bearing-Thrust, Plastic Cage |
| 4 | 105-6184 | 1 | Seal Overhaul Kit |

Idler Assembly No. 103-7349

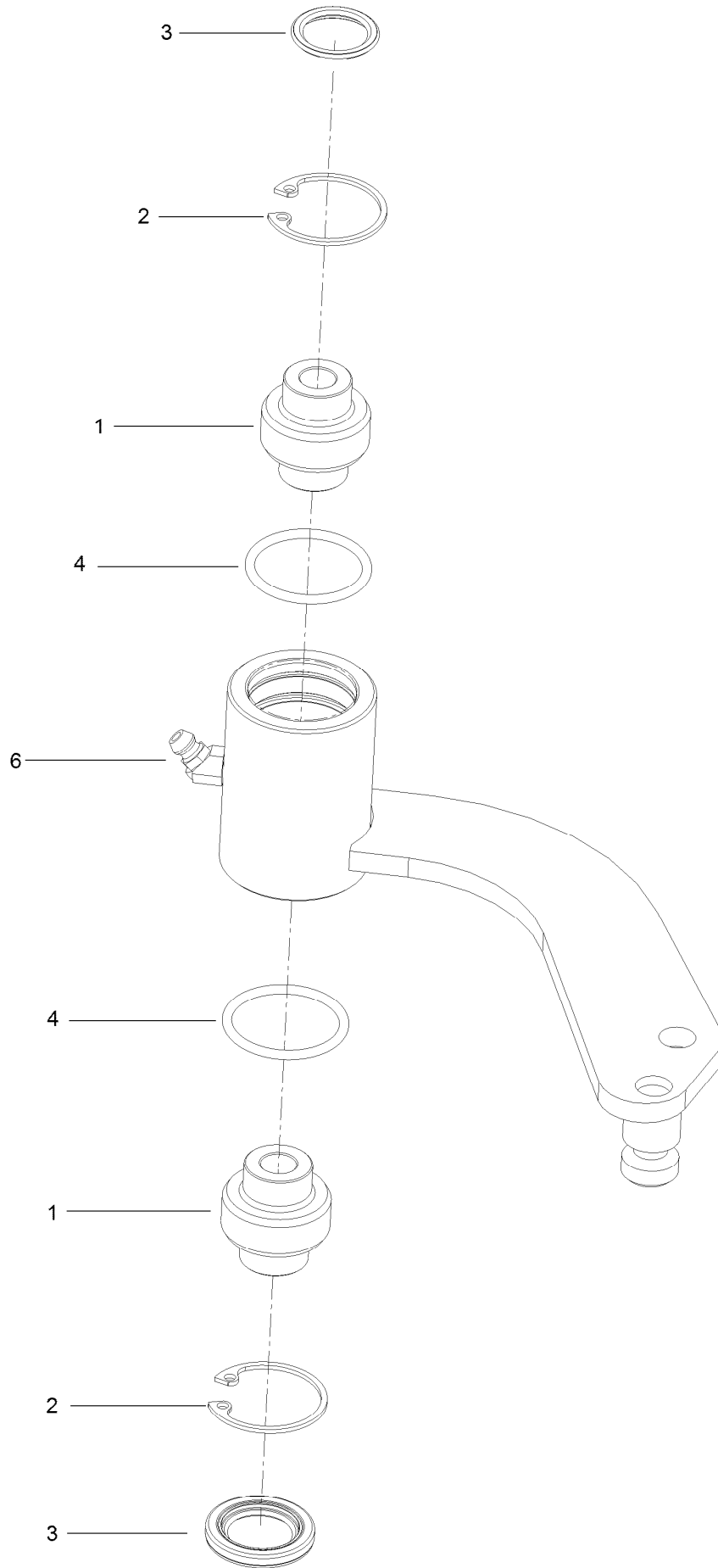

Idler Assembly No. 103-7349 (continued)

| <i>Ref.</i> | <i>Part Number</i> | <i>Qty.</i> | <i>Description</i> |
|-------------|--------------------|-------------|--------------------|
| 1 | 103-3504 | 2 | Bearing-Spherical |
| 2 | 32120-10 | 2 | Ring-Snap |
| 3 | 103-3506 | 2 | Seal-Lip, Single |

| <i>Ref.</i> | <i>Part Number</i> | <i>Qty.</i> | <i>Description</i> |
|-------------|--------------------|-------------|----------------------|
| 4 | 106-7159 | 2 | O-Ring |
| 6 | 302-11 | 1 | Fitting-Lube, 45 DEG |

Hopper Assembly

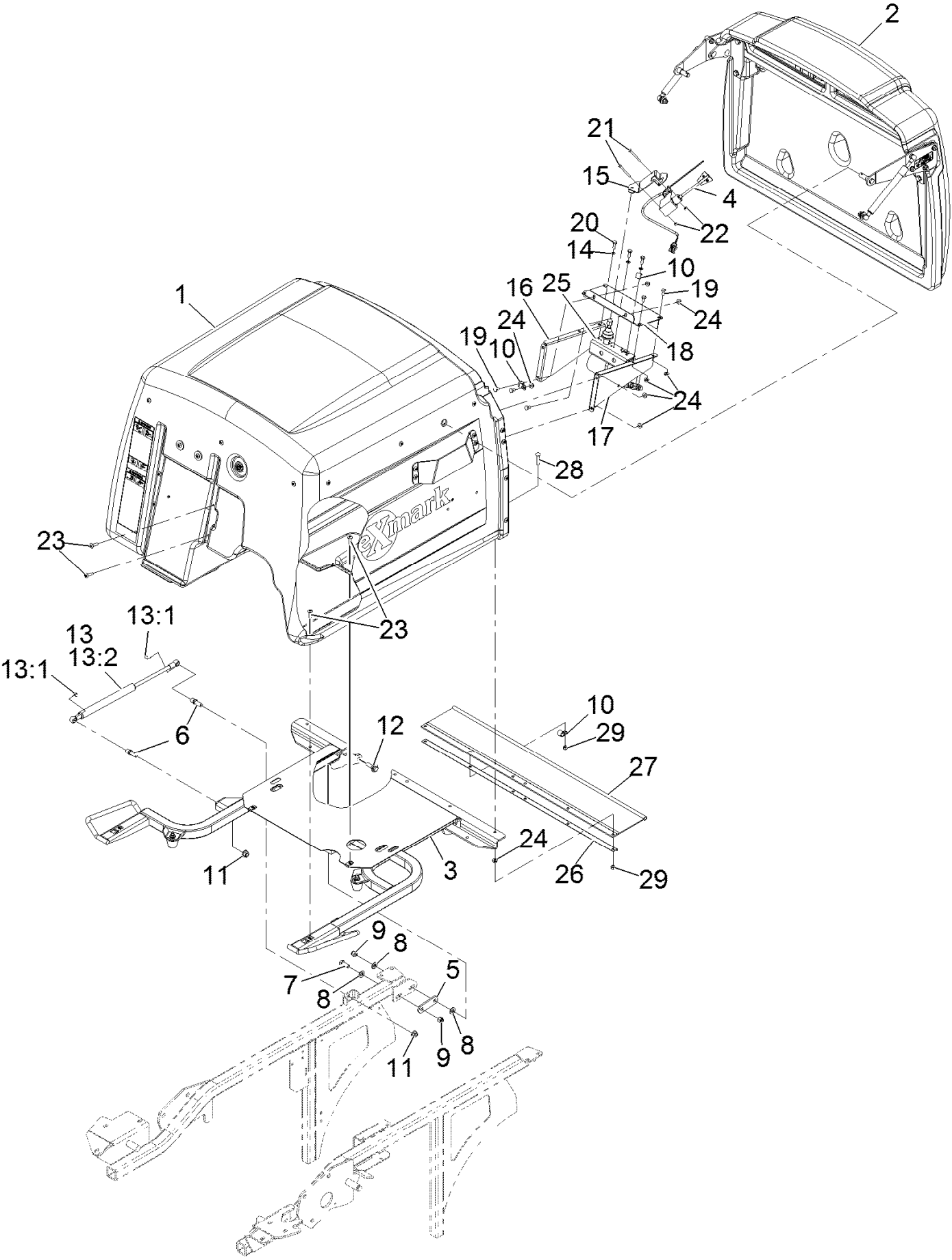

Hopper Assembly (continued)

| <i>Ref.</i> | <i>Part Number</i> | <i>Qty.</i> | <i>Description</i> | <i>Ref.</i> | <i>Part Number</i> | <i>Qty.</i> | <i>Description</i> |
|-------------|--------------------|-------------|-----------------------|-------------|--------------------|-------------|-------------------------|
| 1 | 103-9457 | 1 | Asm, Hopper | 15 | 109-3648 | 1 | Mount-Switch |
| 2 | 103-9456 | 1 | Asm, Door Hopper | 16 | 103-6067-03 | 1 | Bracket-Drive Motor, LH |
| 3 | 109-4086 | 1 | Hopper Frame ASM | 17 | 103-6068-03 | 1 | Bracket-Drive Motor, RH |
| 4 | 103-9466 | 1 | Asm, Fill Sensor | 18 | 103-7085-03 | 1 | Plate-Switch |
| 5 | 1-633068 | 2 | Arm-Lift, Deck | 19 | 321-2 | 7 | Screw-HH |
| 6 | 103-5426 | 2 | Stud-Ball | 20 | 329-4 | 3 | Screw-HH |
| 7 | 323-6 | 2 | Screw-HH | 21 | 3250-48 | 2 | Screw-PPH |
| 8 | 3256-24 | 6 | Washer-Flat | 22 | 3296-2 | 2 | Nut-Lock, NI |
| 9 | 3296-39 | 4 | Nut-Lock, NI | 23 | 32105-32 | 8 | Screw-TTH |
| 10 | 1-513762 | 3 | Clip-Loom | 24 | 32128-33 | 17 | Nut-HF |
| 11 | 33005-00 | 2 | Nut-HF | 25 | 109-3853 | 1 | Motor |
| 12 | 614672 | 2 | Bolt-Shoulder | 26 | 103-6022-03 | 1 | Channel-Hopper Frame |
| 13 | 109-0716 | 1 | Damper Kit | 27 | 103-6025 | 1 | Deflector-Grass |
| 13:1 | 103-8325 | 2 | Clip-Retainer | 28 | 3229-4 | 6 | Screw-CARR |
| 13:2 | 103-5425 | 1 | Shock-Gas Compression | 29 | 3296-42 | 6 | Nut-Lock, NI |
| 14 | 1-303435 | 3 | Washer-Spring | | | | |

Hopper Assembly No. 103-9457

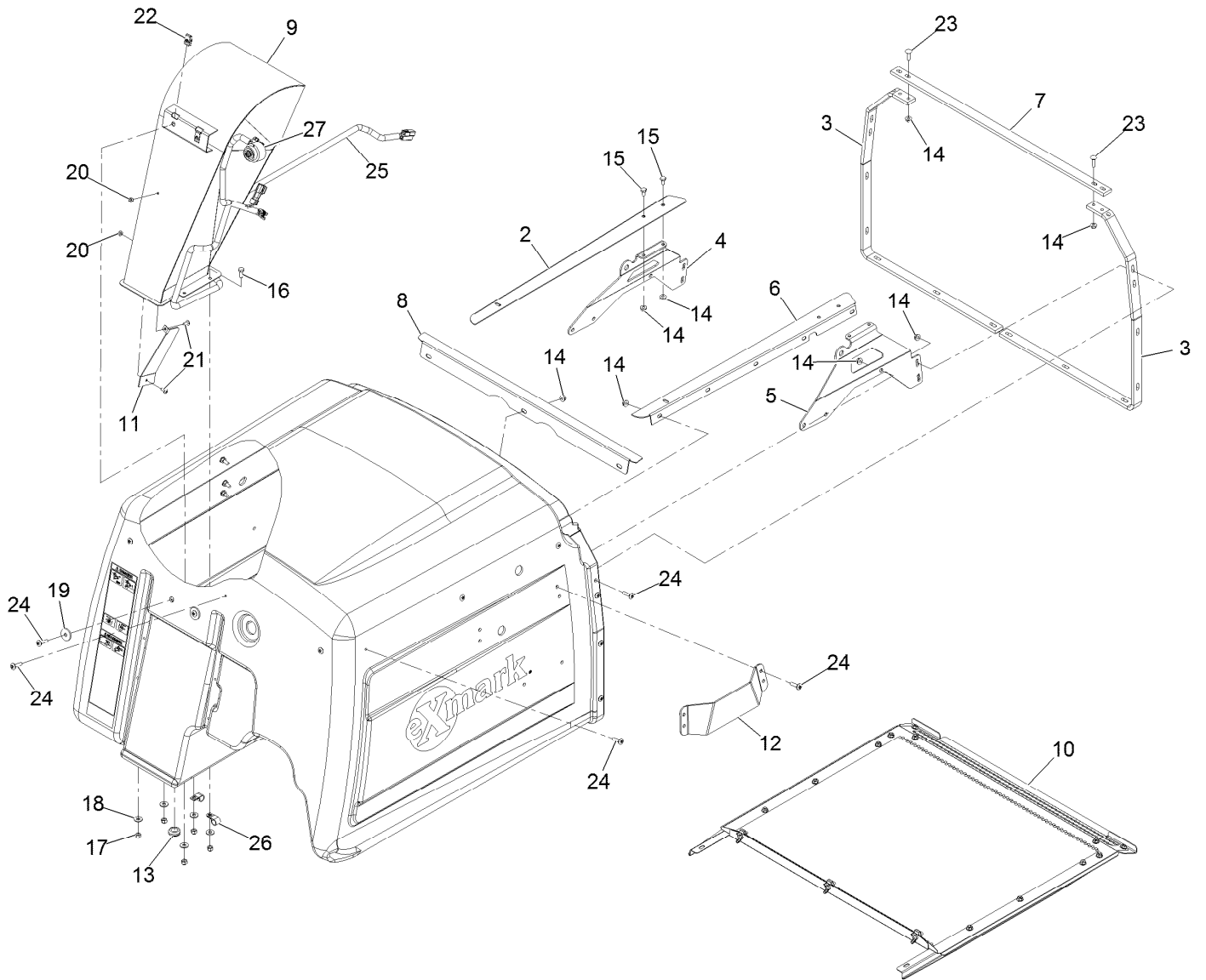

Hopper Assembly No. 103-9457 (continued)

| <i>Ref.</i> | <i>Part Number</i> | <i>Qty.</i> | <i>Description</i> | <i>Ref.</i> | <i>Part Number</i> | <i>Qty.</i> | <i>Description</i> |
|-------------|--------------------|-------------|---------------------------|-------------|--------------------|-------------|-----------------------------|
| 2 | 103-5736-03 | 1 | Angle-Screen Track, RH | 16 | 321-4 | 5 | Screw-HH 1/4-20 X 3/4 |
| 3 | 103-5045-03 | 2 | Reinforcement-Hopper | 17 | 3296-42 | 5 | Nut-Nyloc 1/4-20 |
| 4 | 103-5751-03 | 1 | Brace-Door Pivot, RH | 18 | 3256-2 | 5 | Washer-1/4 Std |
| 5 | 103-5749-03 | 1 | Brace-Door Pivot, LH | 19 | 1-613235 | 2 | Washer |
| 6 | 103-5774-03 | 1 | Angle-Screen Track, LH | 20 | 3296-2 | 2 | Nut-Nyloc #10-24 |
| 7 | 103-5772-03 | 1 | Bracket-Frame Connect | 21 | 32122-30 | 2 | Screw-Truss HD #10-24 X 1/2 |
| 8 | 103-7035-03 | 1 | Channel-Screen, Front | 22 | 107069 | 2 | Nut-Retainer-Panel 1/4-20 |
| 9 | 109-3650-03 | 1 | Diffuser | 23 | 3229-2 | 4 | Bolt-Carriage 1/4-20 X 1 |
| 10 | 109-0717 | 1 | Hopper Screen ASM | 24 | 32105-32 | 27 | Screw-Truss HD 1/4-20 X 1 |
| 11 | 103-8680 | 1 | Deflector-Discharge Chute | 25 | 103-8800 | 1 | Harness-Wire, Hopper |
| 12 | 109-4019 | 2 | Plate-Guard | 26 | 1-513762 | 2 | Clip-Loom 1/2 |
| 13 | 1-543296 | 1 | Grommet | 27 | 103-0205 | 1 | Alarm-Tone, Dual |
| 14 | 32128-33 | 33 | Nut-Whizlock 1/4-20 | | | | |
| 15 | 321-2 | 4 | Screw-HH 1/4-20 X 1/2 | | | | |

Hopper Door Assembly No. 103-9456

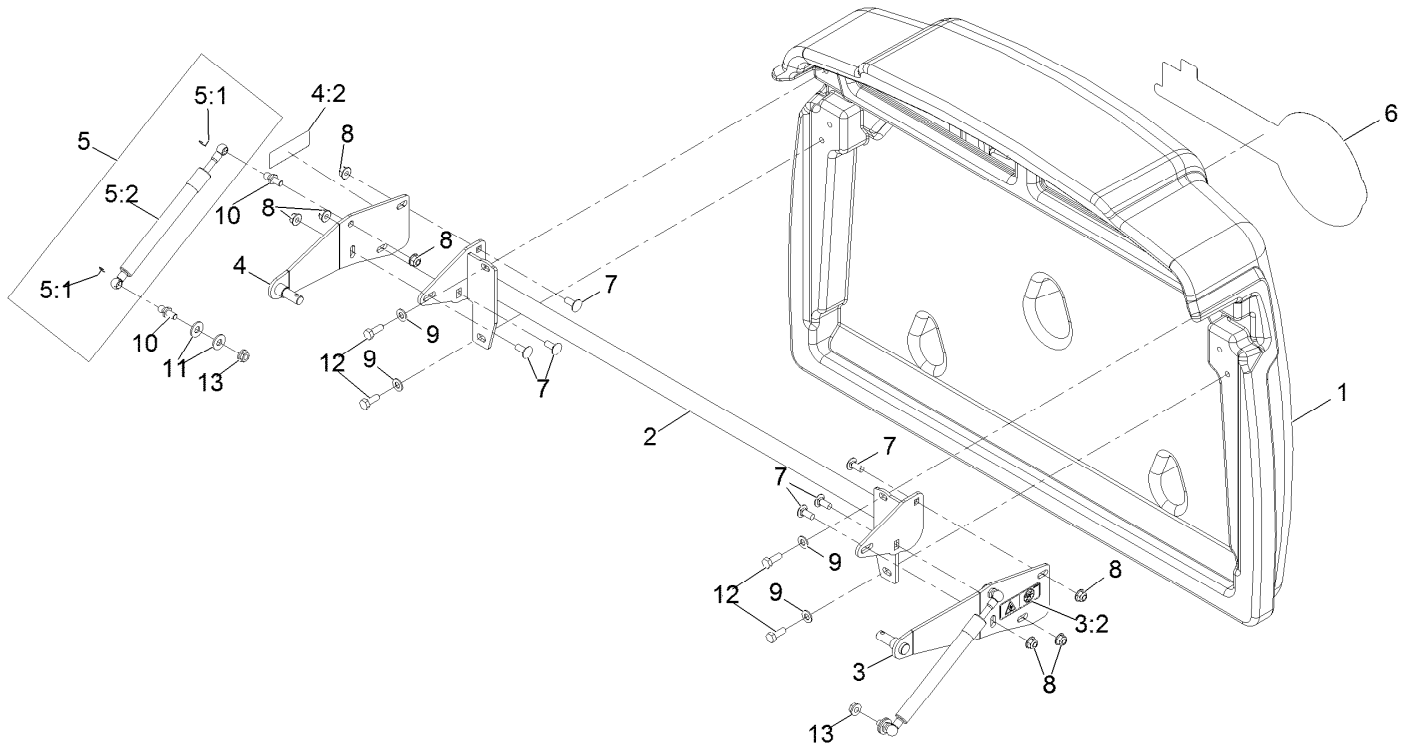

Hopper Door Assembly No. 103-9456 (continued)

| <i>Ref.</i> | <i>Part Number</i> | <i>Qty.</i> | <i>Description</i> | <i>Ref.</i> | <i>Part Number</i> | <i>Qty.</i> | <i>Description</i> |
|-------------|--------------------|-------------|----------------------------|-------------|--------------------|-------------|--------------------|
| 1 | 109-3955 | 1 | Door, 9.5 Bushel Hopper | 6 | 126-7353 | 1 | Decal-Exmark Logo |
| 2 | 109-4153-03 | 1 | Support-Door | 7 | 3230-23 | 6 | Screw-CARR |
| 3 | 109-4253 | 1 | LH Door Pivot ASM | 8 | 104-8300 | 8 | Nut-Flange, NI |
| 3:2 | 120-0625 | 1 | Decal-Warning, Pinch Point | 9 | 3256-23 | 4 | Washer-Flat |
| 4 | 109-4254 | 1 | RH Door Pivot ASM | 10 | 103-5752 | 4 | Stud-Ball |
| 4:2 | 120-0625 | 1 | Decal-Warning, Pinch Point | 11 | 3256-3 | 4 | Washer-Flat |
| 5 | 109-0715 | 2 | Damper Kit | 12 | 322-4 | 4 | Screw-HH |
| 5:1 | 103-8324 | 2 | Clip-Retainer | 13 | 32128-20 | 2 | Nut-HF |
| 5:2 | 103-5746 | 1 | Shock-Gas Tension | | | | |

Hopper Screen Assembly No. 109-0717

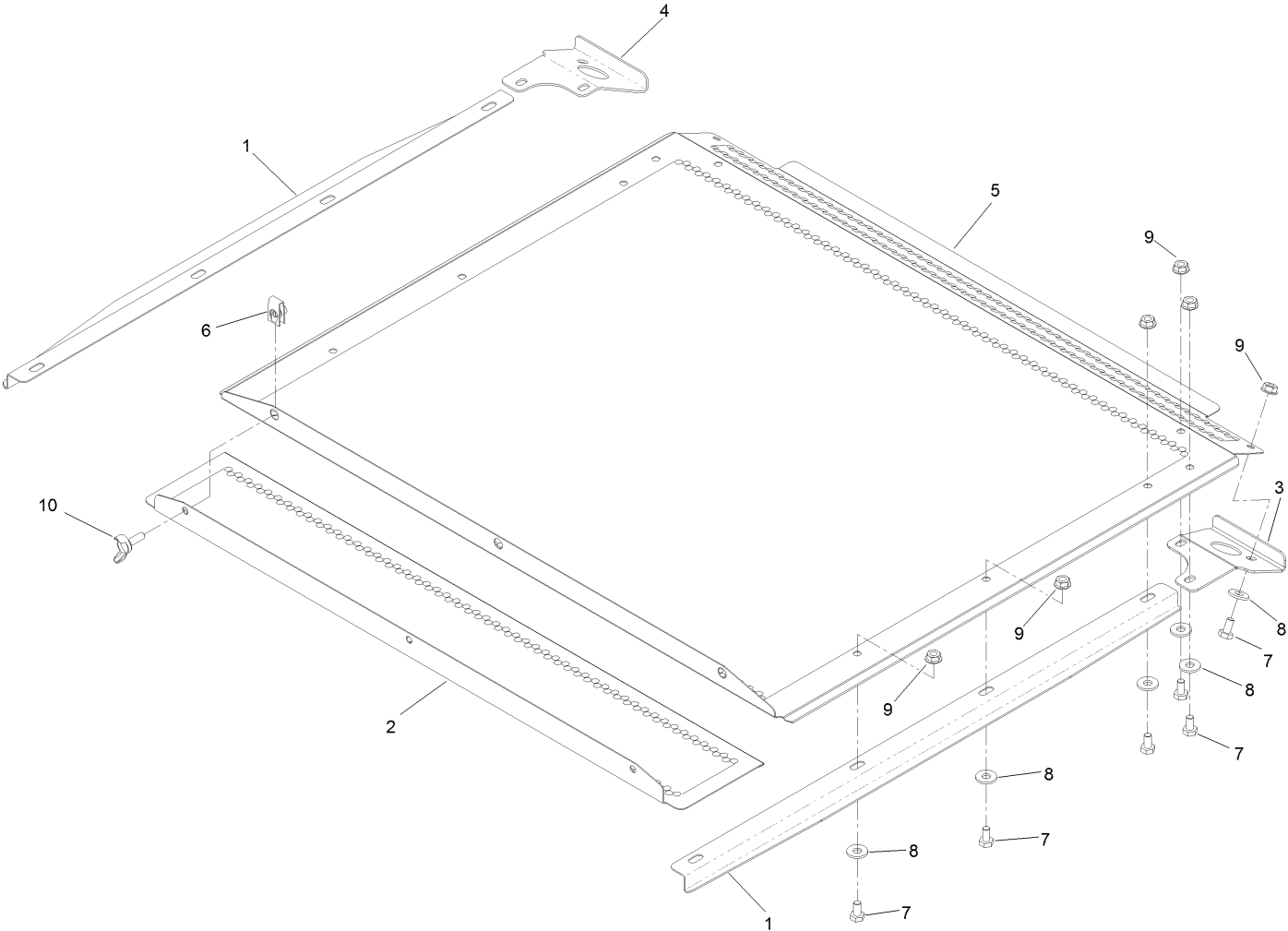

Hopper Screen Assembly No. 109-0717 (continued)

| <i>Ref.</i> | <i>Part Number</i> | <i>Qty.</i> | <i>Description</i> | <i>Ref.</i> | <i>Part Number</i> | <i>Qty.</i> | <i>Description</i> |
|-------------|--------------------|-------------|-------------------------|-------------|--------------------|-------------|--------------------|
| 1 | 103-8203-03 | 2 | Guide-Screen | 6 | 107069 | 3 | Clip |
| 2 | 103-7048-03 | 1 | Panel-Screen, Removable | 7 | 321-2 | 12 | Screw-HH |
| 3 | 103-7098-03 | 1 | Handle-Screen, LH | 8 | 3256-2 | 12 | Washer-Flat |
| 4 | 103-7099-03 | 1 | Handle-Screen, RH | 9 | 32128-33 | 12 | Nut-HF |
| 5 | 103-5745-03 | 1 | Panel-Screen, Hopper | 10 | 109-1063 | 3 | Screw-Wing |

Hopper Frame Assembly No. 109-4086

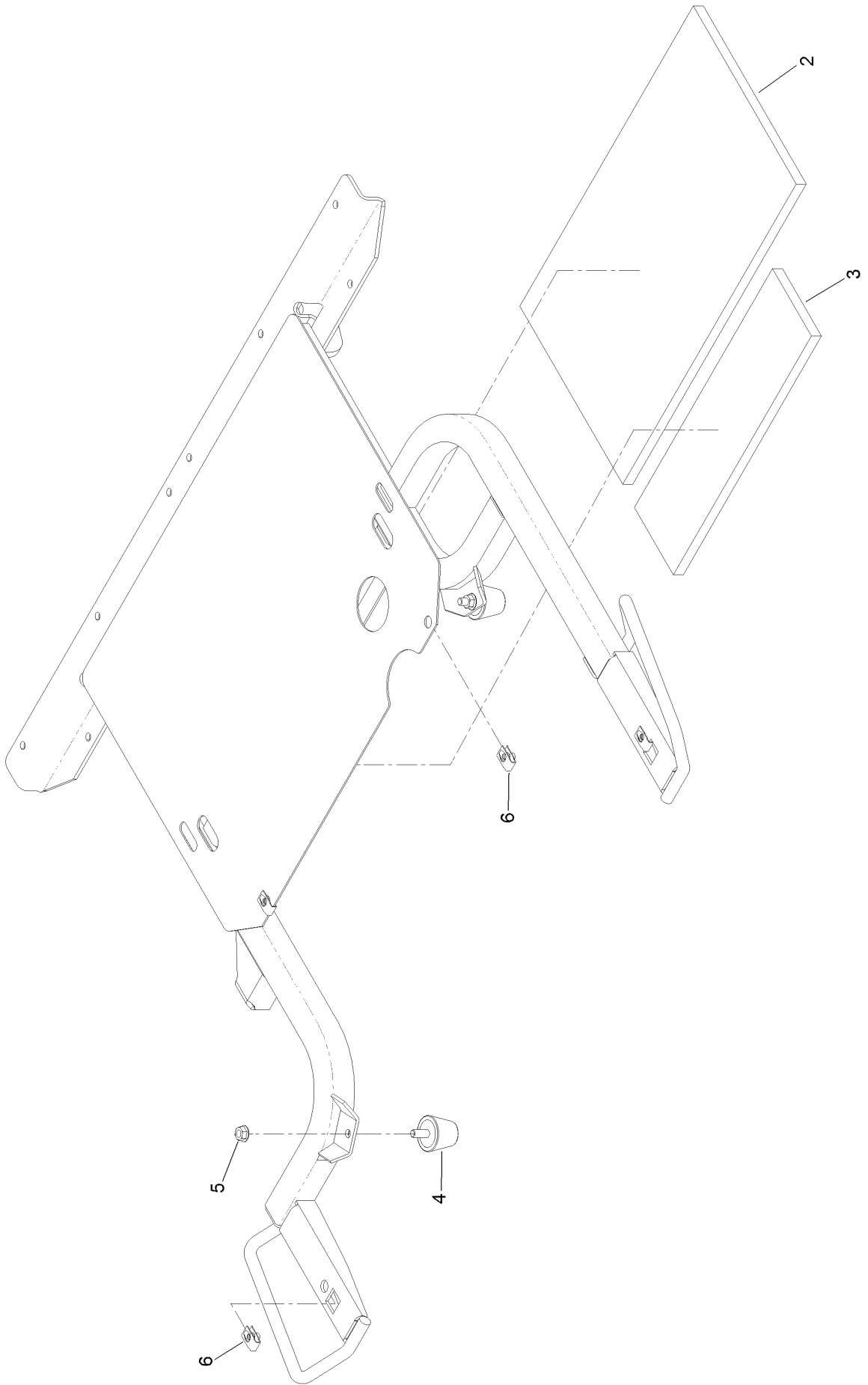

Hopper Frame Assembly No. 109-4086 (continued)

| <i>Ref.</i> | <i>Part Number</i> | <i>Qty.</i> | <i>Description</i> |
|-------------|--------------------|-------------|----------------------------|
| 2 | 103-7824 | 1 | Insulation-Foam Pad, Rear |
| 3 | 103-7825 | 1 | Insulation-Foam Pad, Front |
| 4 | 1-543963 | 2 | Bumper-Rubber |

| <i>Ref.</i> | <i>Part Number</i> | <i>Qty.</i> | <i>Description</i> |
|-------------|--------------------|-------------|--------------------|
| 5 | 32128-20 | 2 | Nut-HF |
| 6 | 107069 | 4 | Clip |

Fill Sensor Assembly No. 103-9466

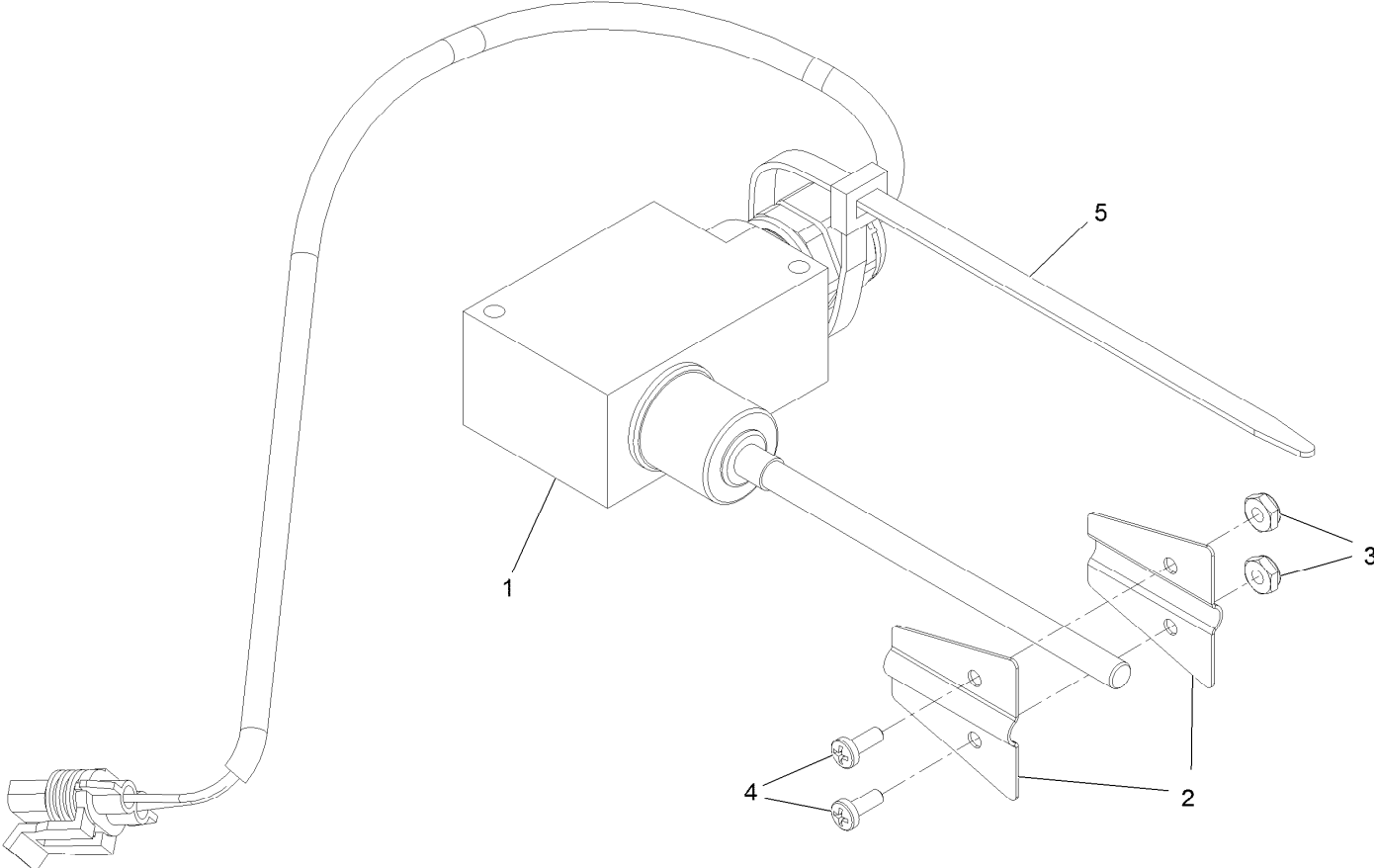

Fill Sensor Assembly No. 103-9466 (continued)

| <i>Ref.</i> | <i>Part Number</i> | <i>Qty.</i> | <i>Description</i> | <i>Ref.</i> | <i>Part Number</i> | <i>Qty.</i> | <i>Description</i> |
|-------------|--------------------|-------------|----------------------|-------------|--------------------|-------------|---------------------------|
| 1 | 109-3854 | 1 | Fill Sensor Wire Kit | 4 | 9107622 | 2 | Screw-PPH #6-32 X 5/8 |
| 2 | 103-8789 | 2 | Flag-Sensor, Fill | 5 | 1-303335 | 1 | Tie-Cable 7 15/16 (Large) |
| 3 | 3296-9 | 2 | Nut-Nyloc #6-32 Thin | | | | |

Electrical Assembly (continued)

| <i>Ref.</i> | <i>Part Number</i> | <i>Qty.</i> | <i>Description</i> | <i>Ref.</i> | <i>Part Number</i> | <i>Qty.</i> | <i>Description</i> |
|-------------|--------------------|-------------|-------------------------|-------------|--------------------|-------------|------------------------------|
| 1 | 1-303287 | 2 | Tie-Cable 5 1/2 (Small) | 21 | | 1 | Battery (300 Cca, Wet) ●■ |
| 2 | 1-513051 | 2 | Switch-N.O. | 22 | 116-4730 | 1 | Cable-Battery, Positive |
| 3 | 1-513152 | 1 | Switch-N.C. | 22:1 | 1-543393 | 1 | Insulator-Solenoid |
| 4 | 126-7505 | 1 | Plate-Switch | 22:2 | 109-2407 | 1 | Insulator-Battery |
| 5 | 116-8812 | 1 | Hour Meter ASM | 23 | 116-9114 | 1 | Harness-Wiring ▲ |
| 6 | 1-522424-03 | 1 | Mount-Spring, Seat | 23:11 | 109355 | 1 | Fuse-Blade, 15 Amp |
| 7 | 1-523415 | 1 | Spring | 23:12 | 109102 | 2 | Fuse-Blade, 25 Amp |
| 8 | 1-543792 | 2 | Wingnut-Nyloc 1/4-20 | 23:14 | 116-0053 | 1 | Cap-Plug |
| 9 | 1-633111 | 1 | Switch | 24 | 321-4 | 4 | Screw-HH 1/4-20 X 3/4 |
| 10 | 1-633181 | 4 | Plate-Tapped | 25 | 32128-33 | 4 | Nut-Whizlock 1/4-20 |
| 11 | 1-633651 | 2 | Bolt-Holddown | 26 | 3217-6 | 1 | Nut-Hex 5/16-18 |
| 12 | 1-643267 | 1 | Indicator-Red Led | 27 | 322-50 | 1 | Screw-HH 5/16-18 X 7 1/2 |
| 13 | 1-643275 | 1 | Relay-12Vdc 40 Amp | 28 | 3256-2 | 2 | Washer-1/4 Std |
| 14 | 104-2065 | 1 | Screw-HWH #10-24 X 3/8 | 29 | 3290-134 | 8 | Screw-HH Machine 10-24 X 5/8 |
| 15 | 103-0205 | 1 | Alarm-Dual Tone 12Vdc | 31 | 3296-29 | 1 | Nut-Nyloc 5/16-18 |
| 16 | 117-2221 | 1 | Switch-Ignition | 32 | 103-8528 | 1 | Hopper Switch Actuator ASM |
| 18 | 103-2106 | 1 | Key-Exmark Logo | 33 | 1-303335 | 4 | Tie-Cable 7 15/16 (Large) |
| 19 | 103-4161-03 | 1 | Hold Down-Battery | | | | |
| 20 | 103-8355 | 1 | Cable-Ground(-) | | | | |

● Obtain locally.

■ Not serviced separately

▲ Use dielectric grease on all unsealed connectors and terminals only. Do not apply in sealed connectors.

Notes:

Notes:

Notes:



MAXIMIZE THE PERFORMANCE OF YOUR EXMARK MACHINE.



EXMARK® PREMIUM ENGINE OIL

Exmark now offers a family of engine oil viscosities to perform well in any environment. Each viscosity has the same synthetic formulation to give you what you need in punishing conditions. We designed each grade to the highest quality, making it ideal even for diesel applications. Coupled with Exmark Premium Fuel Treatment, we have the performance products to make your machine hum.

EXMARK PREMIUM ENGINE OIL SAE 30/10W-30

- Meets zero shear requirements of a straight grade SAE 30 as well as the cold temp properties of a 10W-30.
- Most versatile oil in the industry.
- Superior corrosion protection over conventional oil - even in corrosive, humid environments.

EXMARK PREMIUM ENGINE OIL SAE 20W-50

- Perfect for your big block engine, or any application in severe service.
- Same full synthetic formulation as all other Exmark Premium viscosities.
- Also effective for use in severe service small block engines.

EXMARK PREMIUM ENGINE OIL SAE 10W-50

- Full synthetic formulation gives you peak performance. Don't settle for less.
- Wide span multi-grade combines easy starting in cold weather with maximum protection in high temperature operation.
- Reduce friction & wear over standard mineral formulations.

EXMARK PREMIUM ENGINE OIL SAE 0W-40

- The perfect choice for when the weather turns cold or unpredictable, and your Exmark UTV has to perform.
- Commercial quality for severe service.
- Advanced additive package helps prevent corrosion from long-term storage.

EXMARK PREMIUM ENGINE OIL UTV FORMULATION

- 4-cycle high-temp formulation.
- Heavier viscosity, full synthetic, perfect for your UTV.

EXMARK PREMIUM UTV EXTREME CONDITIONS GEAR OIL

- SAE 80W-90, designed to keep your UTV performing at its peak.
- Shear stable, hypoid gear lube.
- Includes a premium additive system to combat wear, oxidation, rust & corrosion.

Available from your local Exmark dealer. Find your closest dealer at exmark.com

EXMARK ACCESSORIES AND OPTIONS*

MID-MOUNT RIDING ACCESSORIES AND OPTIONS

| | |
|------------------------------------|---------------------------------|
| CUSTOM RIDE SEAT SUSPENSION SYSTEM | OPERATOR CONTROLLED DISCHARGE |
| FULL SUSPENSION SEAT | SUN SHADE |
| DECK LIFT ASSIST KIT | TRASH CONTAINER |
| HITCH KIT | TURF STRIPER |
| LIGHT KIT | ULTRA VAC COLLECTION SYSTEM |
| 12V POWER PORT | ULTRA VAC QUICK DISPOSAL SYSTEM |
| MICRO-MULCH SYSTEM | |

OUT-FRONT RIDING ACCESSORIES AND OPTIONS

| | |
|------------------------------------|---------------------------------|
| CUSTOM RIDE SEAT SUSPENSION SYSTEM | SNOW BLADE |
| DUAL-TAIL WHEEL | SNOWBLOWER |
| FLOOR PAN EXTENDER | SUN SHADE |
| HITCH KIT | TRASH CONTAINER |
| LIGHT KIT | ULTRA VAC COLLECTION SYSTEM |
| MICRO-MULCH SYSTEM | ULTRA VAC QUICK DISPOSAL SYSTEM |
| ROLL OVER PROTECTION SYSTEM (ROPS) | WEATHER CAB |

WALK-BEHIND ACCESSORIES AND OPTIONS

| | |
|--------------------|--------------|
| GRASS CATCHER | TURF STRIPER |
| MICRO-MULCH SYSTEM | STANDON |

*Some accessories and options not available for some models.

Place Model No. and Serial No.
Label Here (Included in the Literature
Pack) or Fill in Below

Model No. _____

Serial No. _____

Date Purchased _____

Engine Model No. and Spec. No. _____

Engine Serial No. (E/No) _____

© 2015 Exmark Mfg. Co., Inc.
Industrial Park Box 808
Beatrice, NE 68310
All Rights Reserved

Part No. 4502-727 Rev. A
(402) 223-6300
Fax (402) 223-5489
Printed in the USA.

