

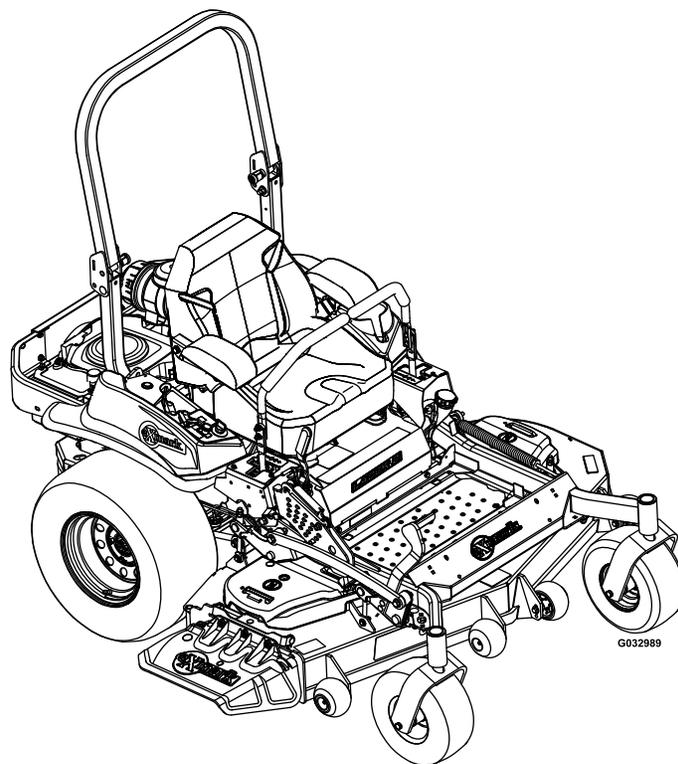

LAZER Z[®] X-SERIES

Model No. LZX740EKC526T0—Serial No. 31600000 and Up

Picture below may not reflect actual product.



Parts Manual

Ordering Replacement Parts

To order replacement parts, please supply the part number, the quantity, and the description of each part desired.

Understanding Reference Numbers

Each identified part in an illustration has a reference number. The reference number for a part also appears in the parts list, along with other information about the part.

This catalog uses two special reference number formats, one to indicate parts in a service assembly and another to indicate the quantity of a given part in an illustration.

Service Assembly Reference Numbers

Parts in service assemblies have reference numbers in the form a:b. The a represents the reference number of the entire service assembly and the b represents a sequential number unique to each part within the service assembly.

For example, a wheel assembly might be identified by reference number 6, the tire by 6:1, the valve by 6:2, and the wheel by 6:3. When you order the assembly identified by reference number 6, you receive all parts identified by reference numbers 6:1, 6:2, and 6:3. However, you may also order any part individually. Reference numbers of this type appear in illustration and in parts lists.

Reference Numbers Indicating Quantity

In an illustration, if a reference number indicates more than one part, the reference number has the form nX y. The n represents the quantity of the part, the X is the multiplication symbol, and the y represents the reference number.

For example, in an illustration, the reference number 2X 37 means that two of the parts identified by reference number 37 are indicated.

List of Abbreviations

AR: as required	HLH: hex lag head	PTH: phillips truss head
ASM: assembly	HOC: height-of-cut	PTO: power-take-off
BBC: blade brake control	HP: high pressure	RH: right hand
BHTF: button head thread forming	HSBH: hex socket button head	ROPS: roll-over protection system
CARR: carriage	HSFH: hex socket flat head	RRB: rear roller brush
CCW: counter clockwise	HSH: hex socket head	SFH: slotted fillister head
CW: clockwise	HWH: hex washer head	SHH: slotted hex head
DEG: degrees	HWHTF: hex washer head thread forming	SHWH: slotted hex washer head
DPA: Dual Point Adjustment	HYD: hydraulic	SPH: slotted pan head
ECM: electronic control module	LH: left hand	SQH: square head
EXT: external	LP: low pressure	SRH: slotted round head
FH: flat head	LPG: Liquefied Petroleum Gas	STD: standard
GA: gauge	NI: nylon insert	TAP: self tapping
HD: heavy-duty	NPTF: national pipe thread fine	TTH: torx truss head
HF: hex flange	PFH: phillips flat head	
HH: hex head	PPH: phillips pan head	
HHF: hex head flange	PPHTF: phillips pan head thread forming	
HHFTF: hex head flange thread forming	PRH: phillips round head	
HJ: hex jam		

Touch Up Paint

Exmark black touch up spray paint – gloss black.

Exmark red touch up paint (spray paint – P/N 1-850337 - .6 oz liquid bottle – P/N 103-9140).



If your Exmark dealer does not have the Exmark part in stock, Exmark will get the parts to the dealer the next business day or the part will be FREE Guaranteed!! (Some restrictions apply. See your participating Exmark Dealer for details.)

Contents

Complete Deck Assembly	4
Deck Assembly No. 109-8592	6
Deck W/Decals Assembly No. 109-9149	8
Deck Idler Assembly No. 116-3755	10
Cutter Housing Assembly No. 103-9539	12
Main Frame Assembly	14
X-Series Decal	16
Roll-Over Protection System	18
Roll-Over Protection System Assembly No. 116-0230	20
Front Caster and Fork Assembly	22
Caster Wheel and Fork Assembly	24
Deck Lift Assembly	26
Height-of-Cut Assembly No. 109-7438	28
Control Assembly	30
Motion Control Assembly	32
Rear Wheel Assembly	34
Park Brake Assembly	36
Seat Assembly	38
Seat W/Tracks Assembly No. 116-8912	40
Fuel Assembly	42
Fuel Tank Assembly No. 126-6494	44
Engine Assembly	46
Hydraulic Assembly	48
LH Hydro Assembly No. 126-1321	50
RH Hydro Assembly No. 126-1322	52
Pump Idler Assembly No. 116-1255	54
Electrical Assembly	56

Complete Deck Assembly

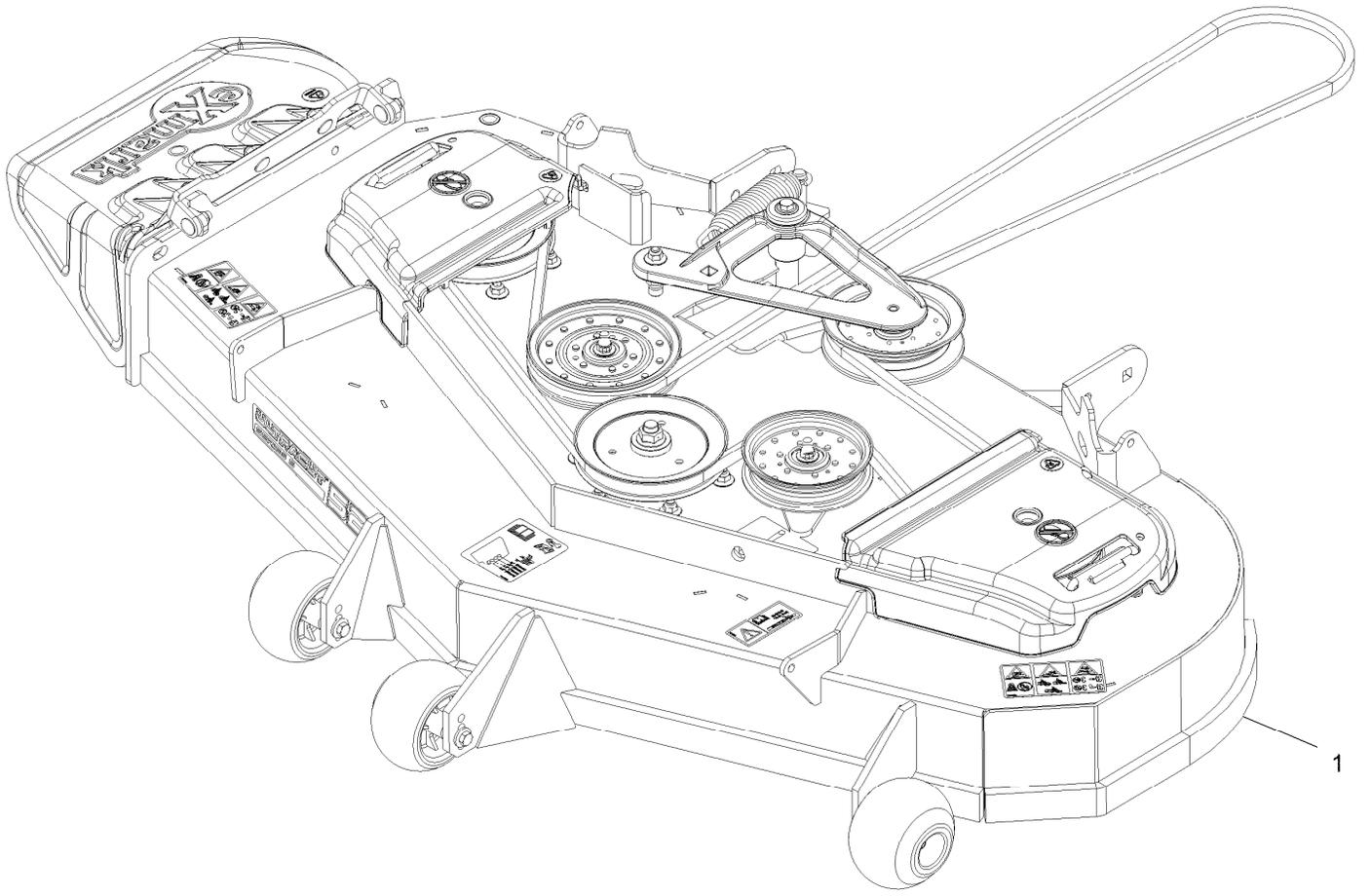

Complete Deck Assembly (continued)

<i>Ref.</i>	<i>Part Number</i>	<i>Qty.</i>	<i>Description</i>
1	109-9645	1	ASM,Deck Complete 526

Deck Assembly No. 109-8592

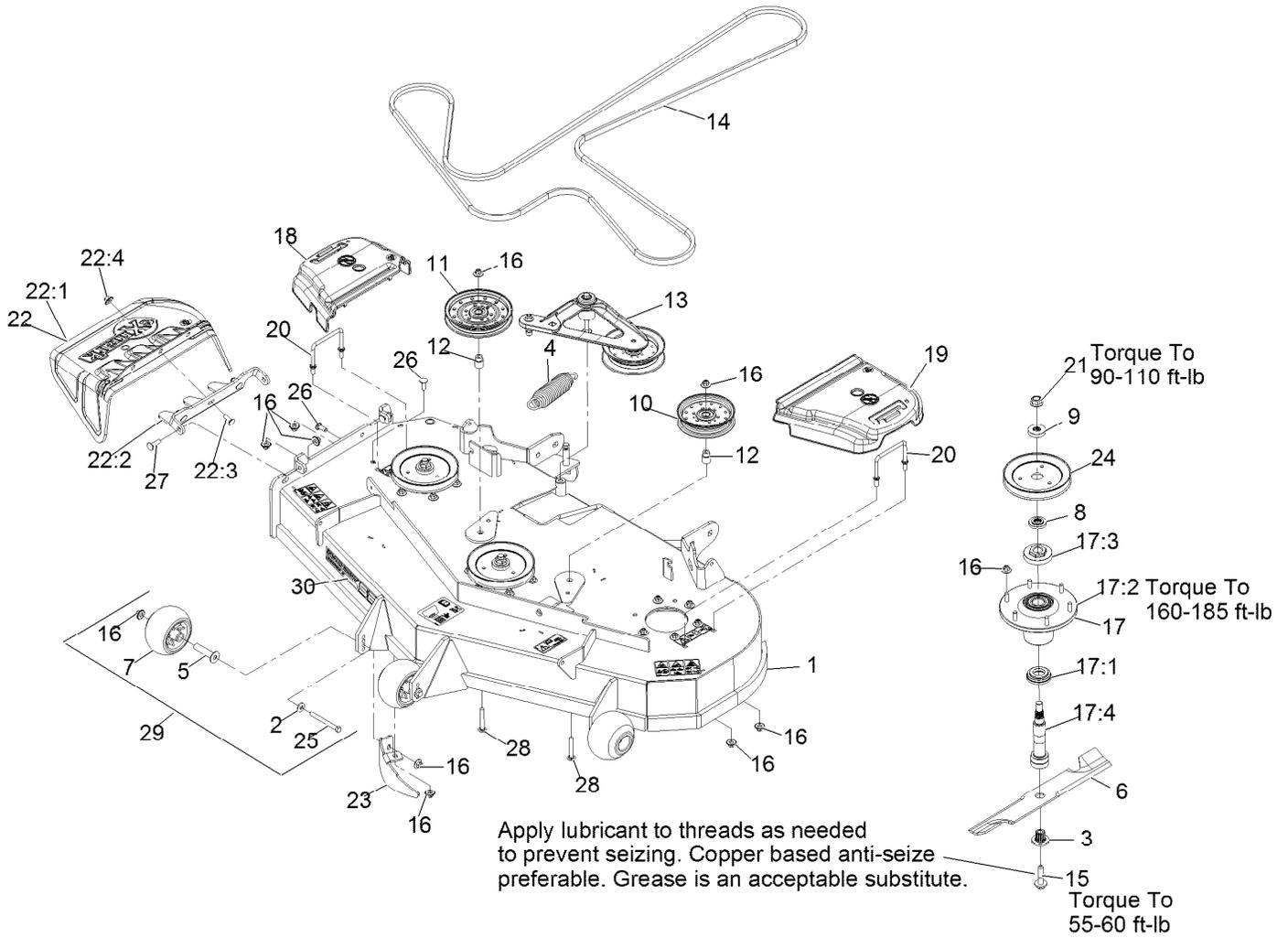

Deck Assembly No. 109-8592 (continued)

<i>Ref.</i>	<i>Part Number</i>	<i>Qty.</i>	<i>Description</i>	<i>Ref.</i>	<i>Part Number</i>	<i>Qty.</i>	<i>Description</i>
1	109-9149	1	ASM,Deck W/ Decals 52	17:2	103-9539	1	Asm, Cutter Housing
2	98-5975	3	Washer-Spring Disc 3/8	17:3	109-0916	1	Nut, Spindle 7/8-14
3	103-3037	3	Bushing, Splined	17:4	109-6881	1	Spindle,Double Spline ■
4	116-6317	1	Spring-Extension	18	109-6935	1	Cover-Belt, RH
5	116-8131	3	Axle, Roller	19	109-6936	1	Cover-Belt, LH
6	103-6402	3	Blade-Notched	20	109-6982	2	Wireform-Cover
6	103-6392	3	Blade, Mulching ●	21	109-7033	3	Nut-Flange 5/8-18 Centerlock
6	103-6387	3	Blade, Low Lift	22	109-7188	1	ASM,Discharge Chute
6	103-6382	3	Blade, Solid	22:1	109-2738	1	Chute, Discharge
6	116-5175	3	Blade-Extreme 2, 18.00"	22:2	109-8675-01	1	Bracket,Discharge Chute
7	103-8415	3	Roller-Anti-Scalp	22:3	3231-22	3	Bolt-Carriage 3/8-16 X 1
8	103-9522	3	Spacer, Splined Stepped	22:4	109-6658	3	Nut-Nyloc 3/8-16 Flg
9	103-9523	3	Spacer, Splined	23	116-5814-01	1	Baffle-Dogleg, Lz-Vt52
10	116-4665	1	Idler-Pulley, Flat	24	116-0185	3	Sheave,Blade Drive
11	116-4667	1	Idler-Pulley, Flat	25	116-9362	3	Screw-HH 3/8-16 X 3 3/4 Gr 8
12	1-633456	2	Bushing, Idler	26	3231-22	2	Bolt-Carriage 3/8-16 X 1
13	116-3755	1	Deck Idler ASM	27	3231-28	2	Bolt-Carriage 3/8-16 X 1 1/4
14	109-4994	1	Belt,V-B X 186.00"	28	3231-44	2	Bolt-Carriage 3/8-16 X 2 1/2
15	109-9220	3	Screw-Sems 1/2-20 X 2.19	29	116-9981	3	Kit, Anti-Scalp Roller
16	109-6658	31	Nut-Nyloc 3/8-16 Flg	30	126-6591	1	Decal, 526
17	109-6917	3	ASM,Spindle Housing				
17:1	103-9504	1	Guard, Bottom				

● Requires installation of mulch kit for proper mulching. See your Exmark dealer for details.

■ Apply Mobil HTS grease (P/N 103-5217 1.5 oz packet) (or a food-grade anti-seize). See operator s manual for locations.

Deck W/Decals Assembly No. 109-9149

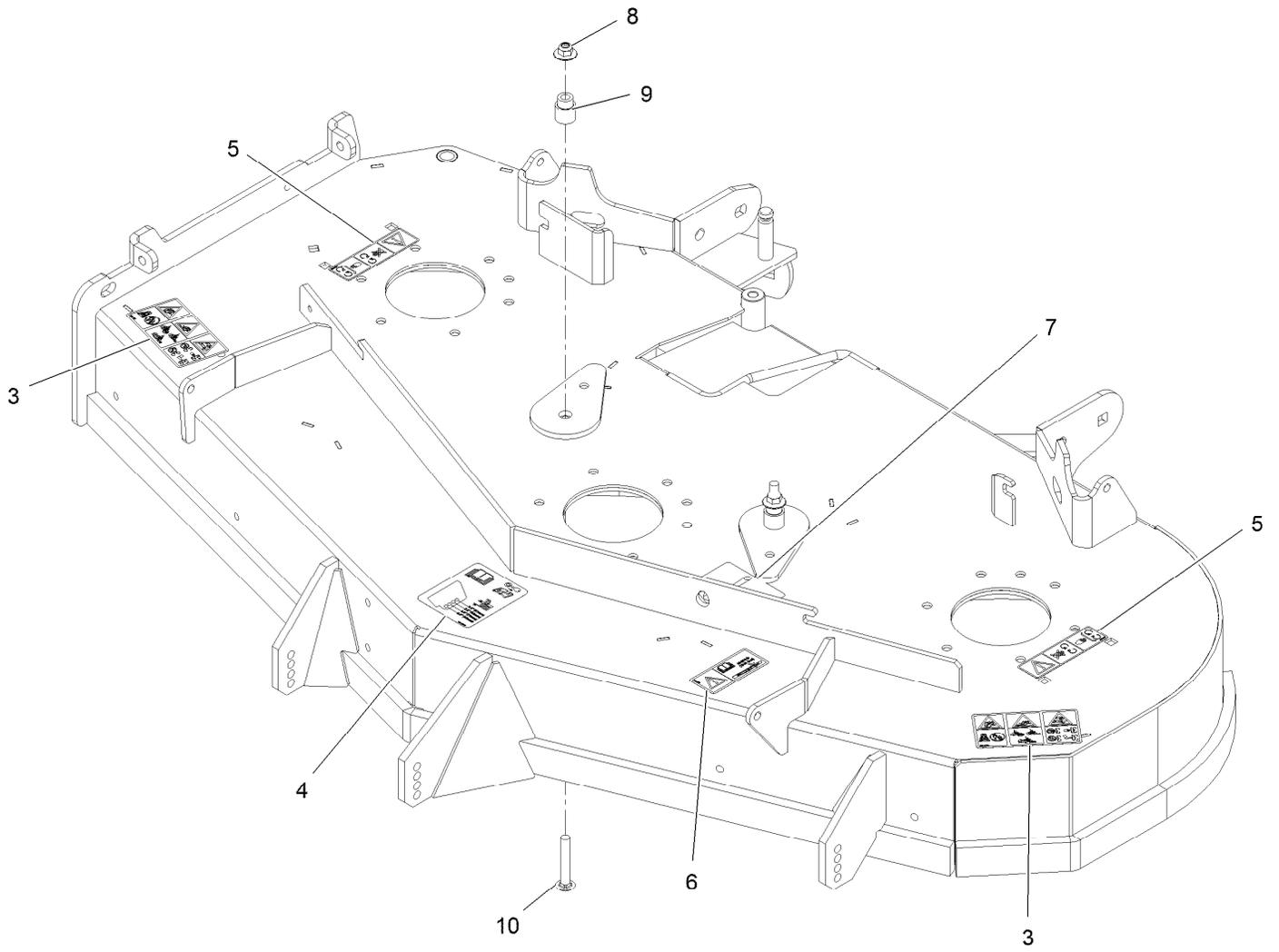

Deck W/Decals Assembly No. 109-9149 (continued)

<i>Ref.</i>	<i>Part Number</i>	<i>Qty.</i>	<i>Description</i>	<i>Ref.</i>	<i>Part Number</i>	<i>Qty.</i>	<i>Description</i>
3	126-6464	2	Decal-Danger Thrown Objects	7	116-8727	1	Decal-Belt Routing
4	109-6036	1	Decal-Roller, Anti-Scalp	8	109-6658	2	Nut-Nyloc 3/8-16 Flg
5	112-9028	2	Decal-Missing, Cover	9	1-633456	2	Bushing, Idler
6	116-8283	1	Decal-Bolt Torque	10	3231-44	2	Bolt-Carriage 3/8-16 X 2 1/2

Deck Idler Assembly No. 116-3755

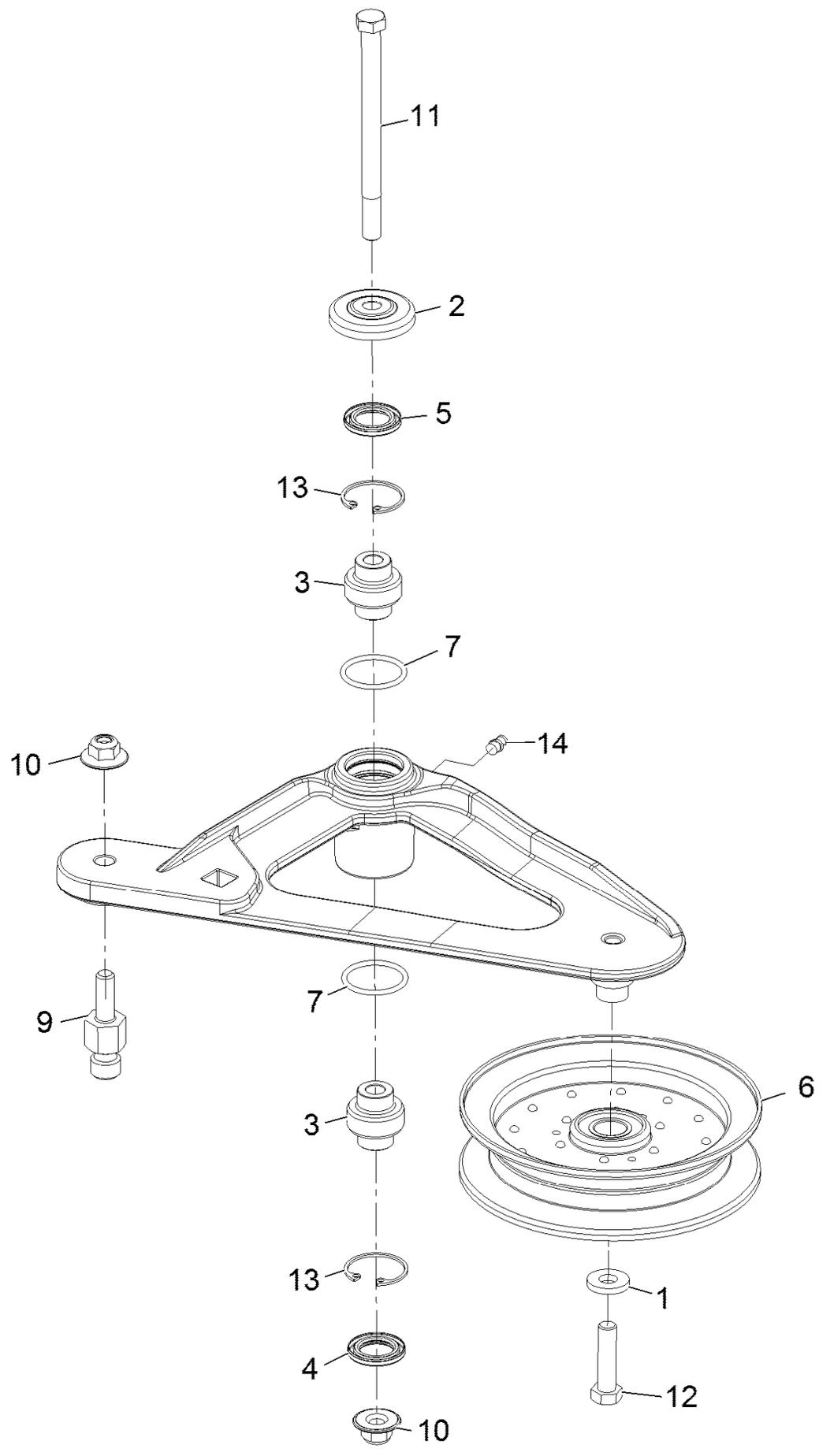

Deck Idler Assembly No. 116-3755 (continued)

<i>Ref.</i>	<i>Part Number</i>	<i>Qty.</i>	<i>Description</i>	<i>Ref.</i>	<i>Part Number</i>	<i>Qty.</i>	<i>Description</i>
1	43-0940	1	Spacer	9	126-0423	1	Pin-Spring, Anchor
2	103-2916	1	Guard-Top	10	109-6658	2	Nut-Nyloc 3/8-16 Flg
3	103-3504	2	Bearing-Spherical	11	109-7409	1	Screw-Shoulder 3/8-16 X 5
4	103-3505	1	Seal-Double Lip	12	323-8	1	Screw-HH 3/8-16 X 1 1/2
5	103-3506	1	Seal-Single Lip	13	32120-10	2	Ring-Retaining
6	116-4668	1	Idler-Pulley, Flanged	14	302-19	1	Zerk-1/4-28 Str
7	106-7159	2	O-Ring				

Cutter Housing Assembly No. 103-9539

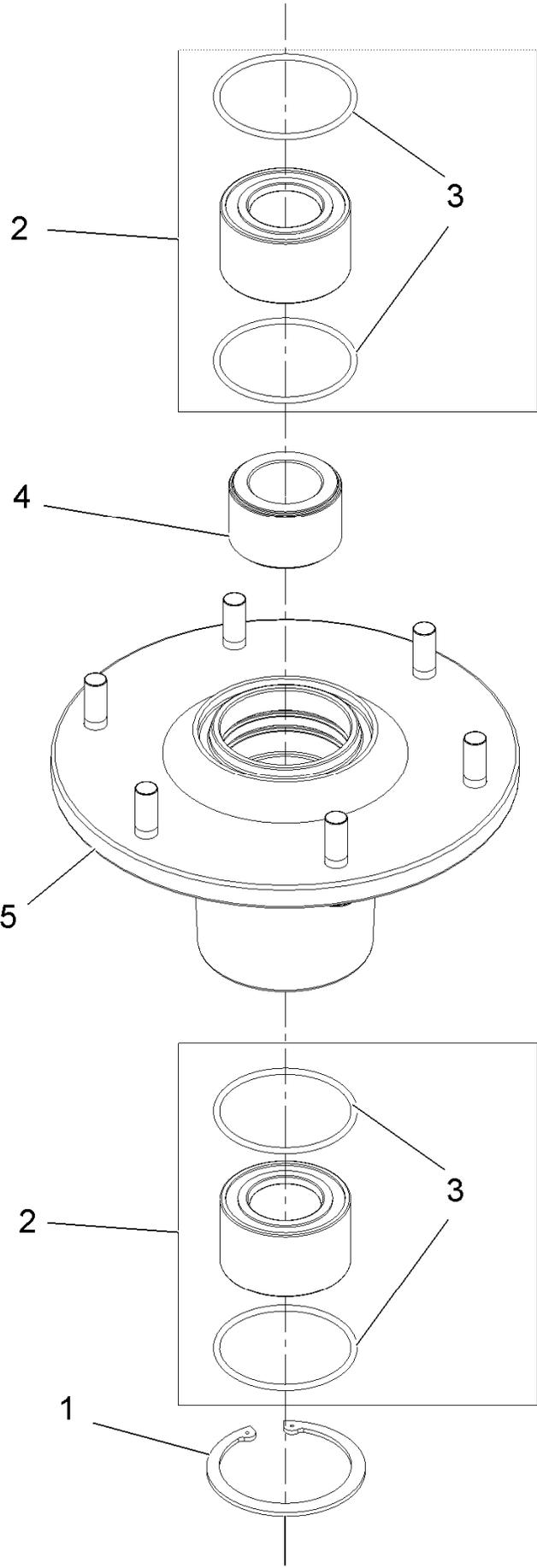

Cutter Housing Assembly No. 103-9539 (continued)

<i>Ref.</i>	<i>Part Number</i>	<i>Qty.</i>	<i>Description</i>
1	92-5581	1	Ring-Retaining
2	109-2064	1	Asm, Bearing W/O-Rings
3	103-5895	4	O-Ring

<i>Ref.</i>	<i>Part Number</i>	<i>Qty.</i>	<i>Description</i>
4	103-9506	1	Spacer, Bearing
5	109-0764	1	Asm, Housing W/Studs

Main Frame Assembly

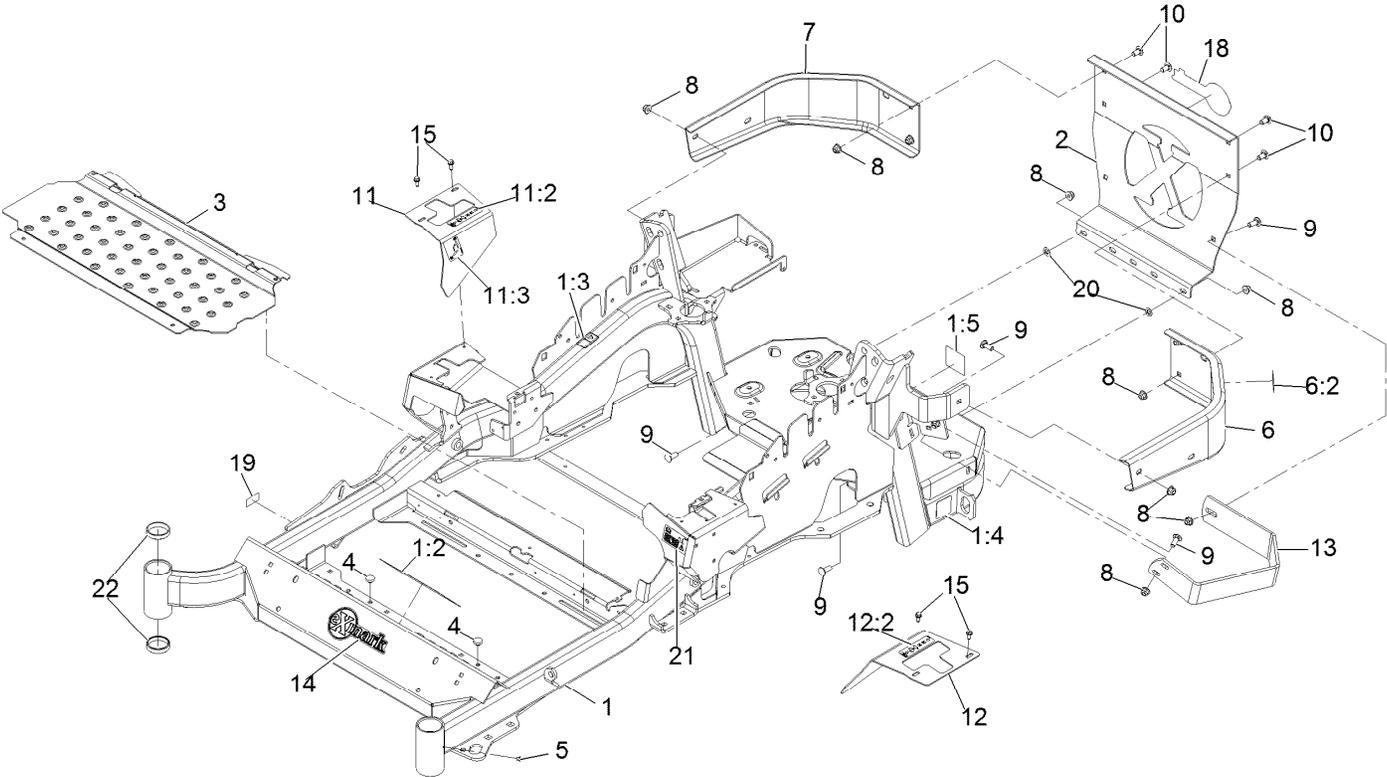

Main Frame Assembly (continued)

<i>Ref.</i>	<i>Part Number</i>	<i>Qty.</i>	<i>Description</i>	<i>Ref.</i>	<i>Part Number</i>	<i>Qty.</i>	<i>Description</i>
1	126-6618	1	Mainframe ASM	11	116-5899	1	RH Motion Control Cover ASM
1:2	132-0871	1	Decal-Danger	11:2	99-8936	1	Decal-Control, Motion
1:3	106-5517	2	Decal-Warning, Hot Surface	11:3	116-5988	1	Decal-Park Brake, Ce
1:4	106-2655	2	Decal-Hazard, Pinched Finger	12	116-0580	1	LH Motion Control Cover ASM
1:5	116-4858	1	Decal-Spark Arrester	12:2	99-8936	1	Decal-Control, Motion
2	109-8863-03	1	Plate,Rear Guard	13	126-2067-03	1	Guard-Muffler
3	116-8898-01	1	Floorpan	14	126-6969	1	Decal-Exmark Logo
4	1-513658	2	Bumper	15	32144-10	4	Screw-HWH 1/4-20 X .62
5	1-811010	2	Plug	18	126-6965	1	Decal-Exmark Logo
6	116-0180	1	LH Bumper ASM	19	126-4345	1	Decal-Patent Ttco.Com
6:2	106-5517	1	Decal-Warning, Hot Surface	20	107-3154	2	Nut-Push 3/8-16
7	116-0057-03	1	Bumper-RH	21	117-3864	1	Decal-Fuel Fill, Ce
8	104-8301	11	Nut-Nyloc 3/8-16 Flg	22	1-543508	4	Cup-Bearing Tapered Roller
9	3231-22	7	Bolt-Carriage 3/8-16 X 1				
10	3231-21	4	Bolt-Carriage 3/8-16 X 3/4				

X-Series Decal

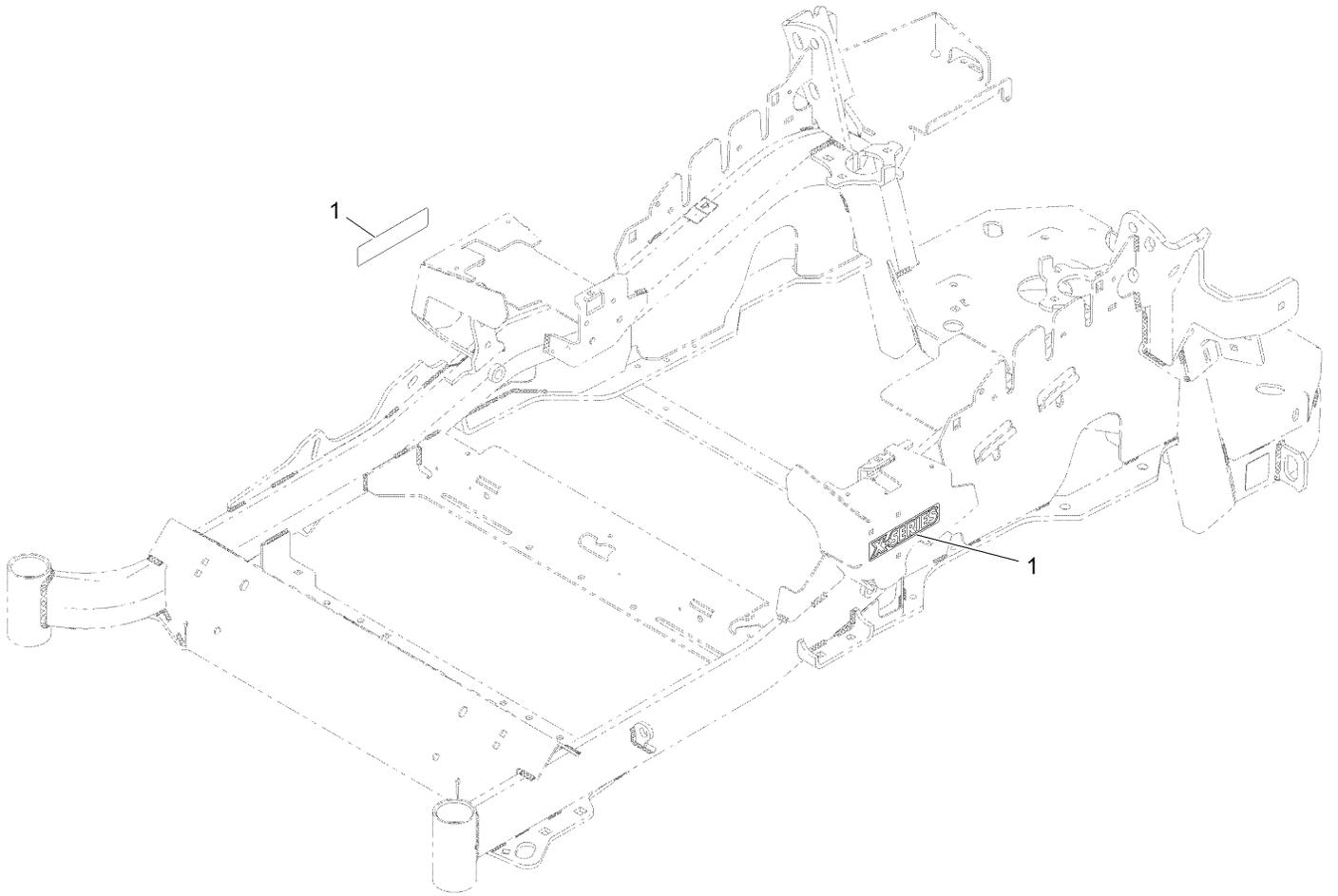

X-Series Decal (continued)

<i>Ref.</i>	<i>Part Number</i>	<i>Qty.</i>	<i>Description</i>
1	126-6573	2	Decal-X-Series

Roll-Over Protection System

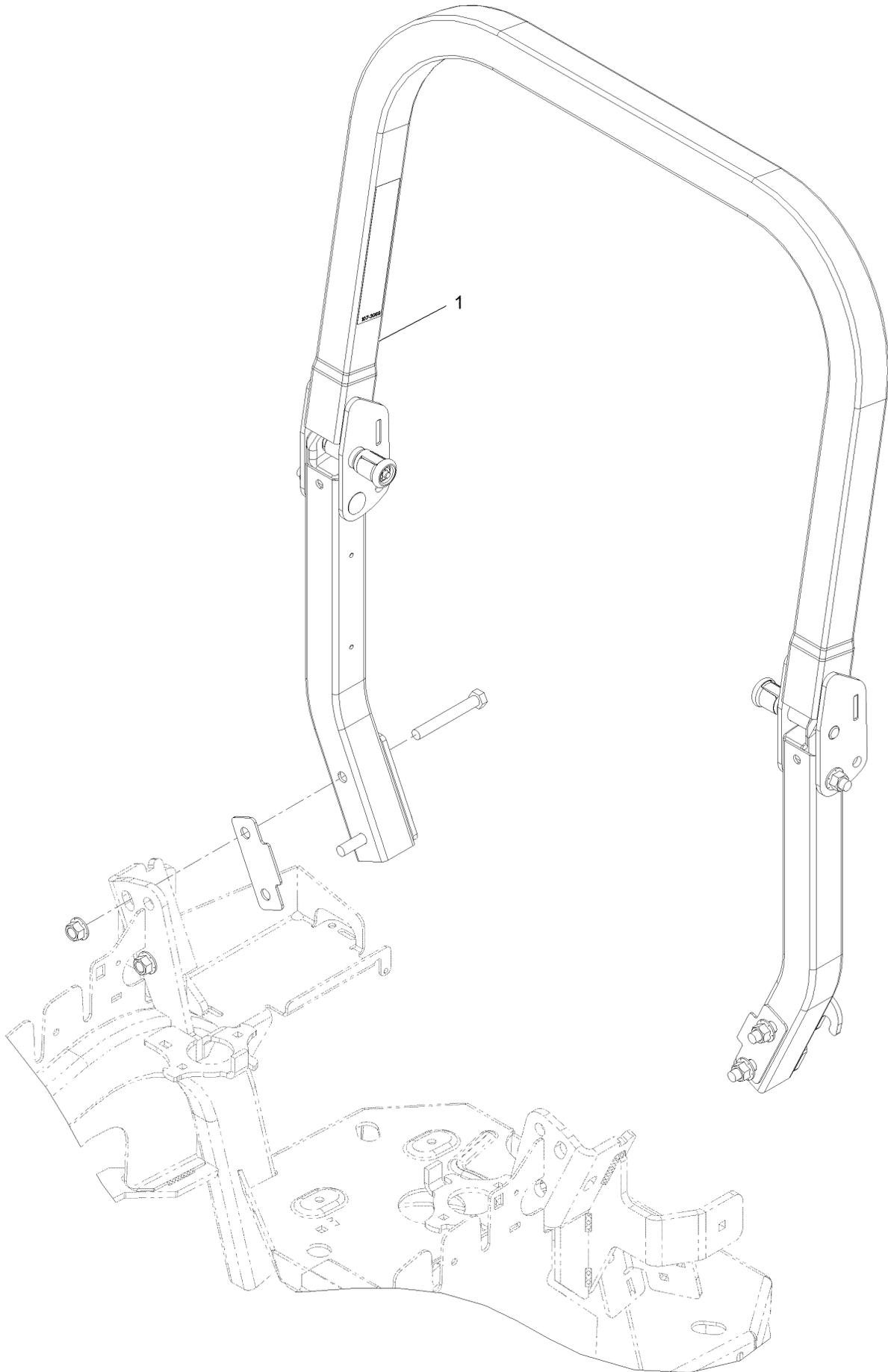

Roll-Over Protection System (continued)

<i>Ref.</i>	<i>Part Number</i>	<i>Qty.</i>	<i>Description</i>
1	116-0230	1	ASM,ROPS Service Exmark

Roll-Over Protection System Assembly No. 116-0230

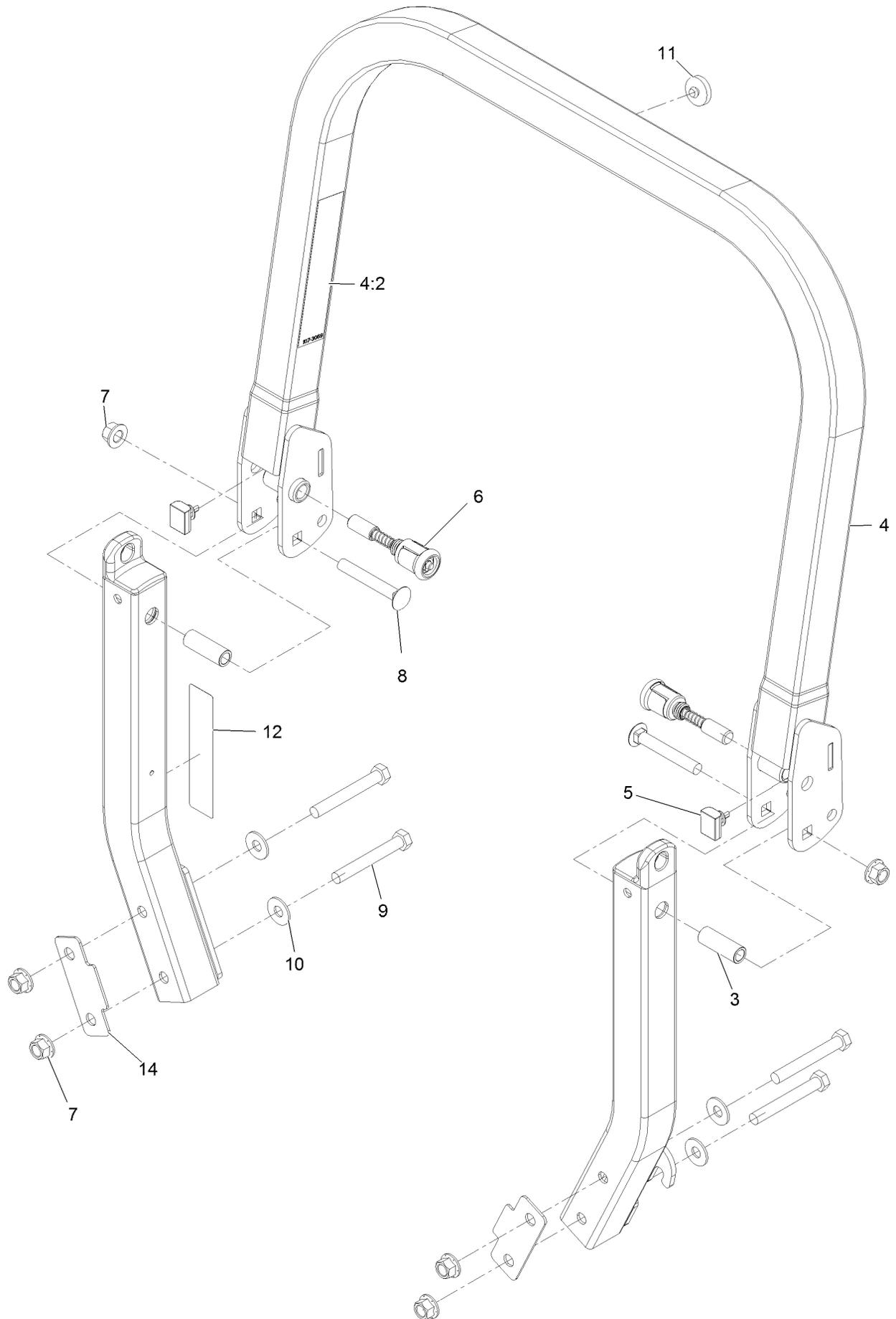

Roll-Over Protection System Assembly No. 116-0230 (continued)

<i>Ref.</i>	<i>Part Number</i>	<i>Qty.</i>	<i>Description</i>	<i>Ref.</i>	<i>Part Number</i>	<i>Qty.</i>	<i>Description</i>
3	109-6653	2	Spacer	8	3233-10	2	Bolt-Carriage 1/2-13 X 3 1/2
4	116-0019	1	Upper ROPS ASM	9	325-35	4	Screw-HH
4:2	107-3069	1	Decal-Warning, Folding ROPS	10	109-9505	4	Washer, Spring Disc 1/2
5	109-5337	2	Bumper-ROPS	11	109-9233	1	Bumper-Push-In, Rubber
6	116-0104	2	Pin-Spring	12	117-0346	1	Decal-Caution, Fuel Vent
7	99-5107	6	Nut-Lock 1/2-13	14	116-0960	2	Spacer

Front Caster and Fork Assembly (continued)

<i>Ref.</i>	<i>Part Number</i>	<i>Qty.</i>	<i>Description</i>
1		2	Front Caster And Fork ASM
			●

● Not serviced separately

Caster Wheel and Fork Assembly

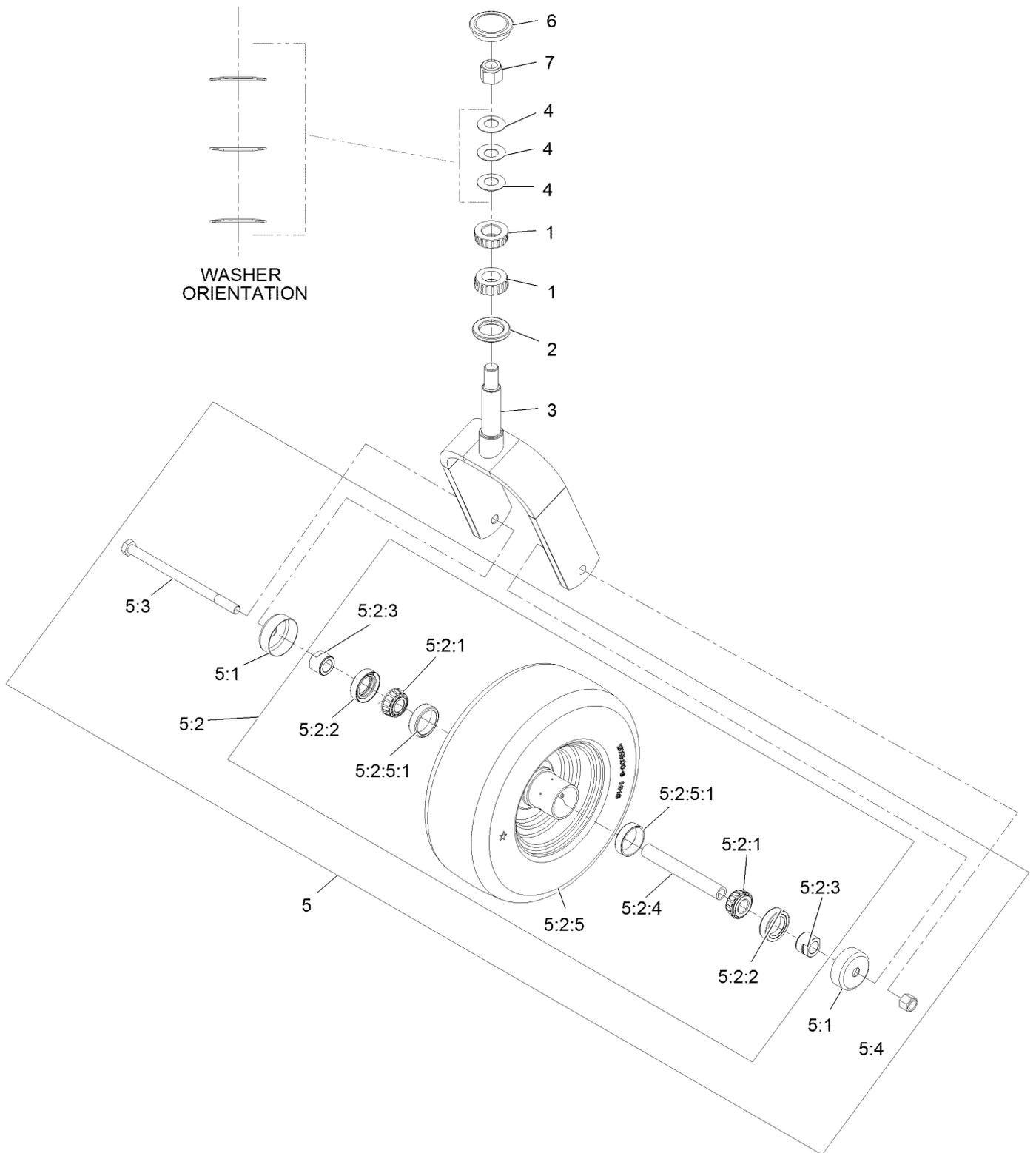

Caster Wheel and Fork Assembly (continued)

<i>Ref.</i>	<i>Part Number</i>	<i>Qty.</i>	<i>Description</i>	<i>Ref.</i>	<i>Part Number</i>	<i>Qty.</i>	<i>Description</i>
1	1-543509	2	Cone-Bearing Tapered Roller	5:2:2	103-0063	2	Seal-Double Lip
2	116-5647	1	Seal-Grease	5:2:3	103-3051	1	Spacer-Nut ■
3	116-6703-01	1	Weld, Fork	5:2:4	126-5360	1	Axle ASM-Caster
4	1-633508	3	Washer-Spring Disc	5:2:5		1	Wheel And Tire ASM ●
5	109-9126	1	Wheel & Tire ASM	5:2:5:1	1-633584	1	Bearing-Cup
5:1	103-2768	2	Guard-Seal	5:3	325-42	1	Screw-HH 1/2-13 X 8
5:2		1	Wheel And Tire ASM ●	5:4	3296-23	1	Nut-Nyloc 1/2-13
5:2:1	1-633585	2	Bearing-Cone Tapered Roller	6	103-4882	1	Cap-Grease
				7	3296-51	1	Nut-Nyloc 3/4-10

● Not serviced separately

■ Use Pro-Lock, Nut Type (P/N 1-840022, .5ml tube) on threads.

Deck Lift Assembly

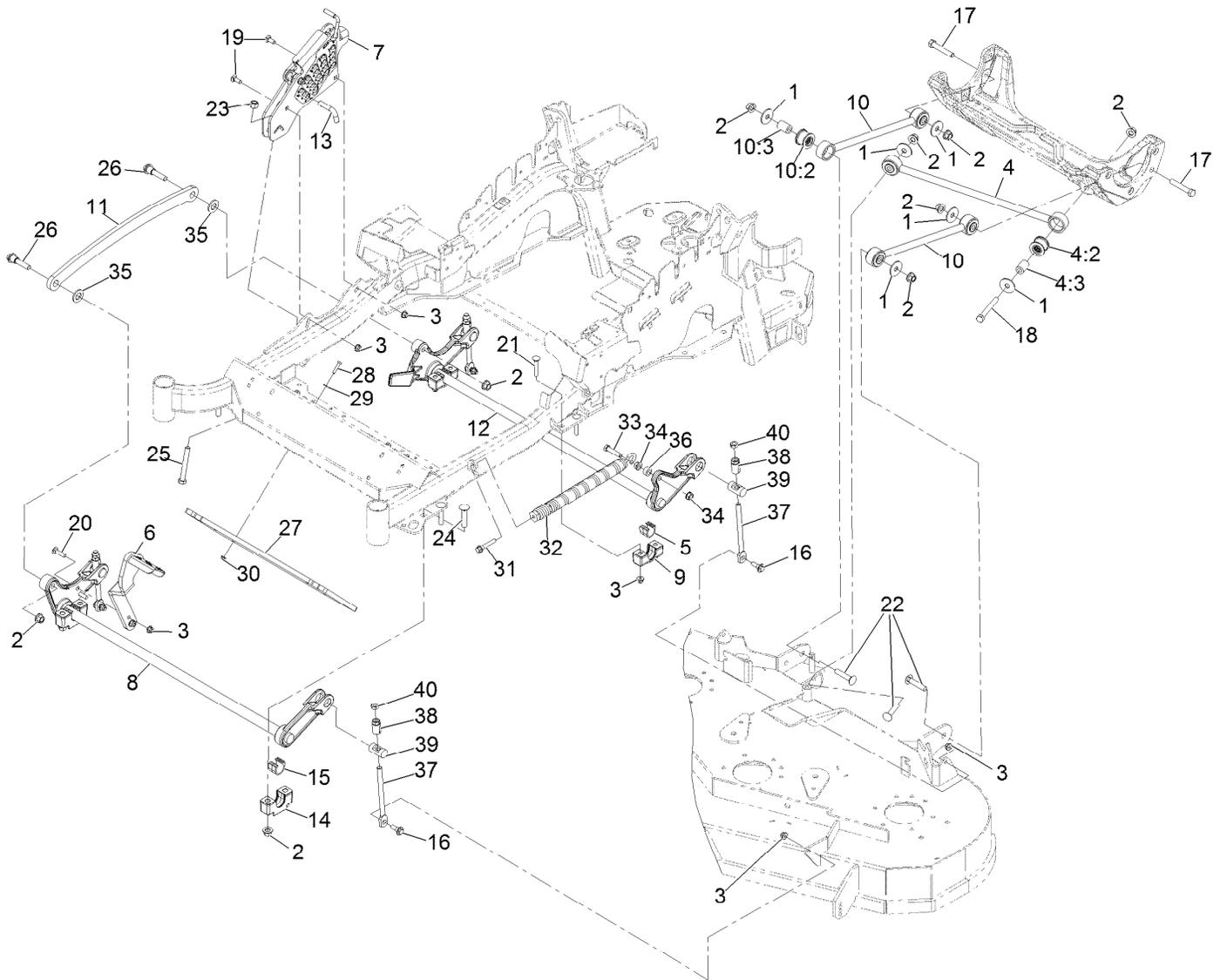

Deck Lift Assembly (continued)

<i>Ref.</i>	<i>Part Number</i>	<i>Qty.</i>	<i>Description</i>	<i>Ref.</i>	<i>Part Number</i>	<i>Qty.</i>	<i>Description</i>
1	86-1990	6	Washer	18	325-17	1	Screw-HH 1/2-13 X 4
2	99-5107	12	Nut-Lock 1/2-13	19	3231-2	2	Bolt-Carriage 3/8-16 X 1
3	104-8301	12	Nut-Nyloc 3/8-16 Flg	20	3231-4	2	Bolt-Carriage 3/8-16 X 1 1/2
4	109-5013	1	Panhard Rod ASM	21	3231-7	4	Bolt-Carriage 3/8-16 X 2 1/4
4:2	109-5009	2	Bushing-Suspension, Rubber	22	3233-34	3	Bolt-Carriage 1/2-13 X 2 1/2
4:3	109-5010	2	Spacer	23	3296-23	1	Nut-Nyloc 1/2-13
5	109-7173	2	Bearing-Cross Shaft, Rear	24	116-1700	4	Bolt-Carriage 1/2-13 X 2 1/2 Spl Neck
6	116-1919-01	1	Lever-Foot	25	116-0559	1	Bolt-HH 1/2-13 X 4 Tap
7	109-7438	1	HOC ASM	26	116-2022	2	Screw-Hex Flange 1/2-13 X 1.90
8	126-2477-03	1	Decklift-Front	27	132-5075-01	1	Weight-Toe Board
9	127-0553	2	Support-Cross Shaft, Bearing Rear	28	321-8	4	Screw-HH 1/4-20 X 1 1/4
10	109-7952	2	Deck Strut ASM	29	3256-22	4	Washer-1/4 Sae
10:2	109-5009	2	Bushing-Suspension, Rubber	30	104-7201	4	Nut-Nyloc 1/4-20 Flg
10:3	109-5010	2	Spacer	31	92-7674	1	Screw-Shcs 3/8-16 X 2.212
11	116-0797-03	1	Link-Lift, Deck	32	116-0886	1	Extension Spring ASM
12	116-2645-03	1	Lift-Deck, Rear	33	109-9065	1	Screw-HH 7/16-14 X 2
13	116-5584	1	Pin-HOC	34	32128-37	2	Nut-Whizlock 7/16-14
14	109-9409	2	Support-Cross Shaft, Bearing	35	3256-28	2	Washer-3/4 Sae
15	109-9410	2	Bearing-Cross Shaft, Front	36	116-2695	1	Spacer
16	109-9840	4	Screw-Hex Flange 3/8-16 X .80	37	109-8007	4	Link-Adjuster, Deck Lift
17	325-12	2	Screw-HH 1/2-13 X 3	38	109-7840	4	Adjuster-Lift, Deck
				39	109-8353	4	Trunnion
				40	3218-5	4	Nut-Jam 1/2-13

Height-of-Cut Assembly No. 109-7438

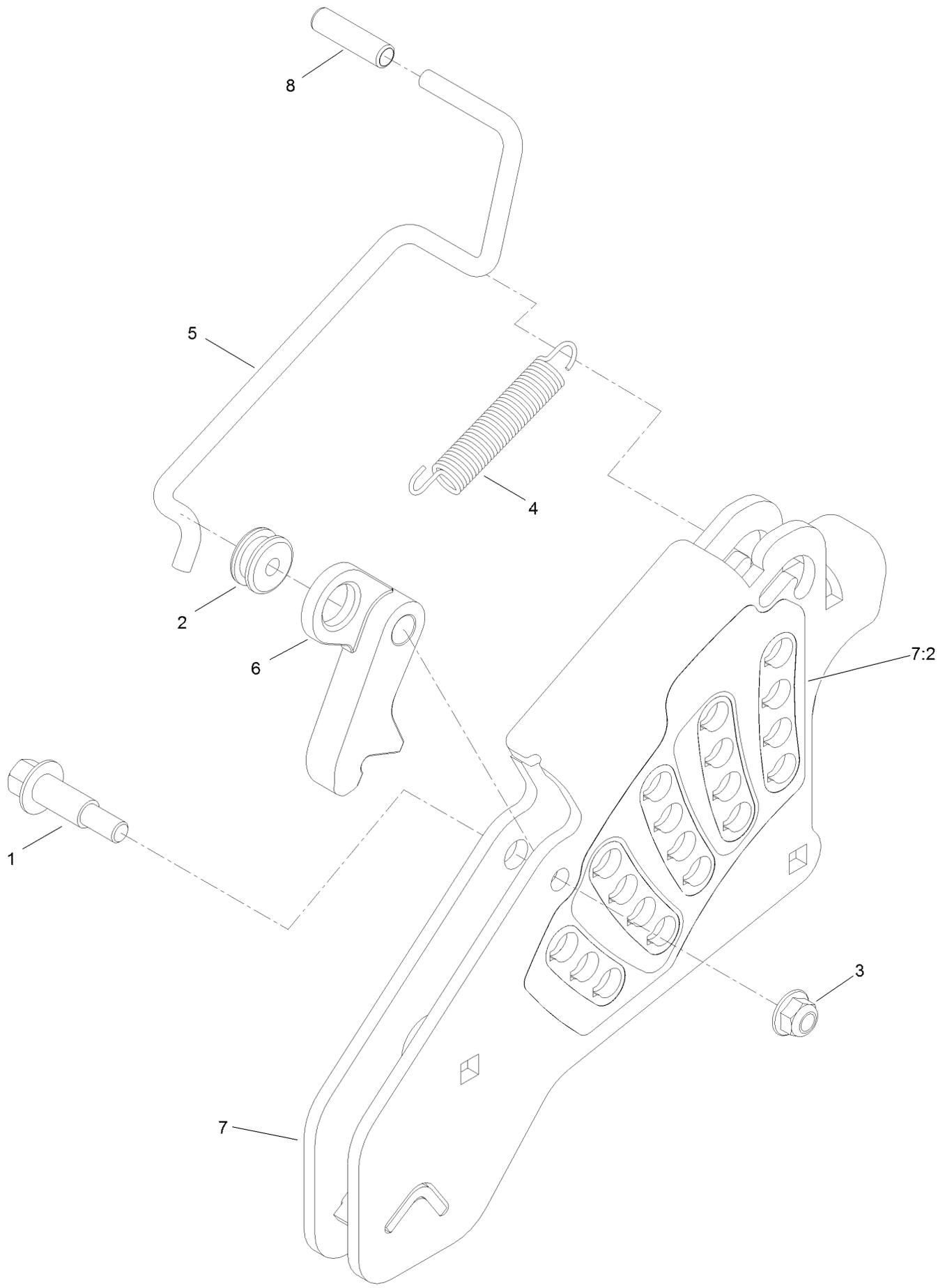

Height-of-Cut Assembly No. 109-7438 (continued)

<i>Ref.</i>	<i>Part Number</i>	<i>Qty.</i>	<i>Description</i>	<i>Ref.</i>	<i>Part Number</i>	<i>Qty.</i>	<i>Description</i>
1	62-1330	1	Bolt-Shoulder	6	116-0118	1	Pawl-Transport, HOC
2	109-7130	1	Grommet	7	109-7335	1	HOC Plate ASM
3	104-8301	1	Nut-Flange, NI	7:2	126-4398	1	Decal-HOC
4	109-7124	1	Spring-Extension	8	109-8250	1	Grip-Lever
5	109-7128	1	Rod-Lock, Transport				

Control Assembly

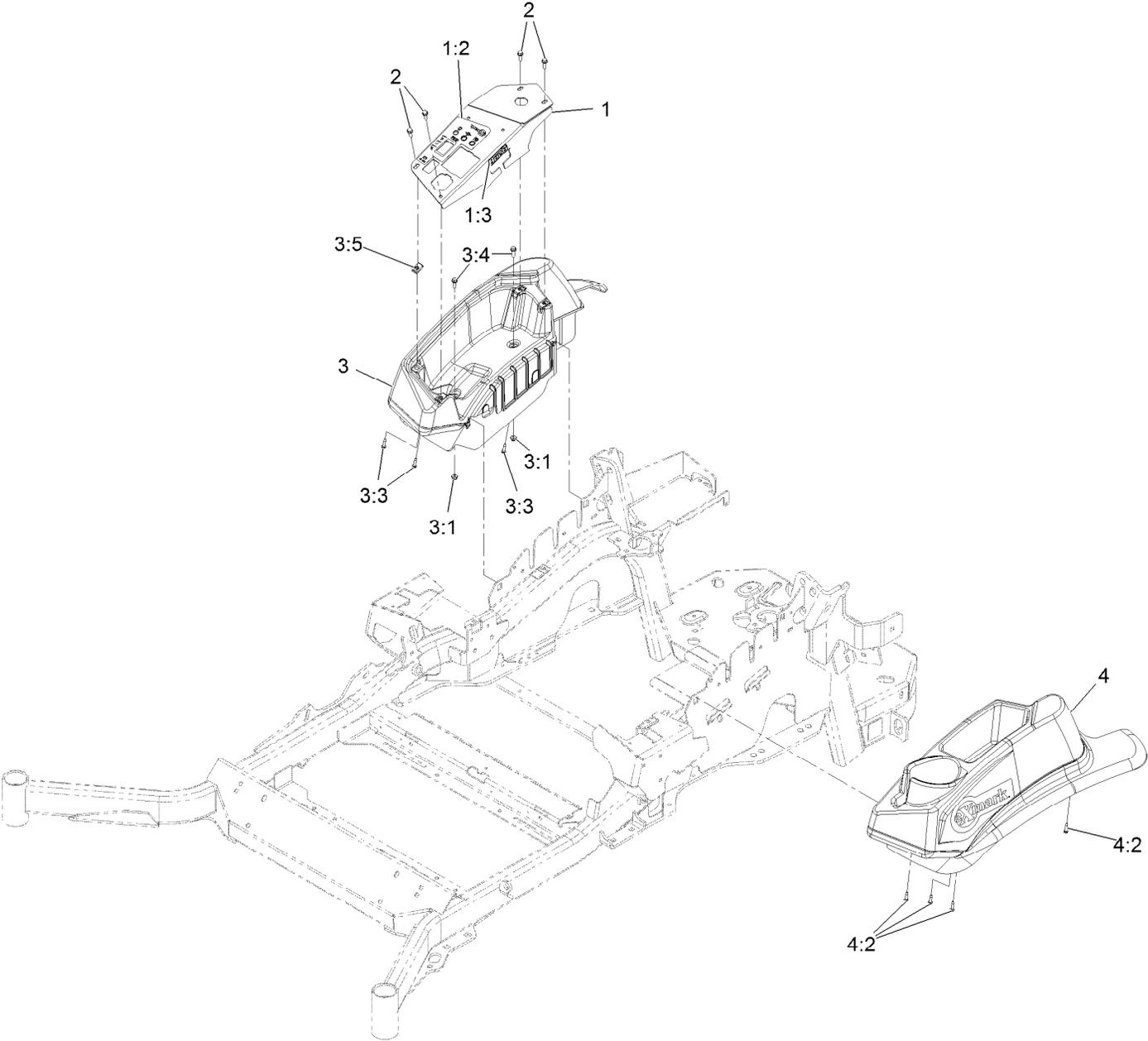

Control Assembly (continued)

<i>Ref.</i>	<i>Part Number</i>	<i>Qty.</i>	<i>Description</i>	<i>Ref.</i>	<i>Part Number</i>	<i>Qty.</i>	<i>Description</i>
1	116-9416	1	Control Panel W/Decal	3:3	109-9345	3	Screw-HWH #10-14 X 3/4 Tf
1:2	126-4108	1	Decal-Console Red	3:4	32105-15	2	Screw-Machine 1/4-20 X 3/4
1:3	114-4466	1	Decal-Fuses	3:5	107069	4	Nut-Retainer-Panel 1/4-20
2	32105-15	4	Screw-Machine 1/4-20 X 3/4	4	109-9342	1	Console.LH Narrow ASM
3	109-9341	1	Console,RH Narrow ASM	4:2	109-9345	4	Screw-HWH #10-14 X 3/4 Tf
3:1	104-7201	2	Nut-Nyloc 1/4-20 Flg				

Motion Control Assembly

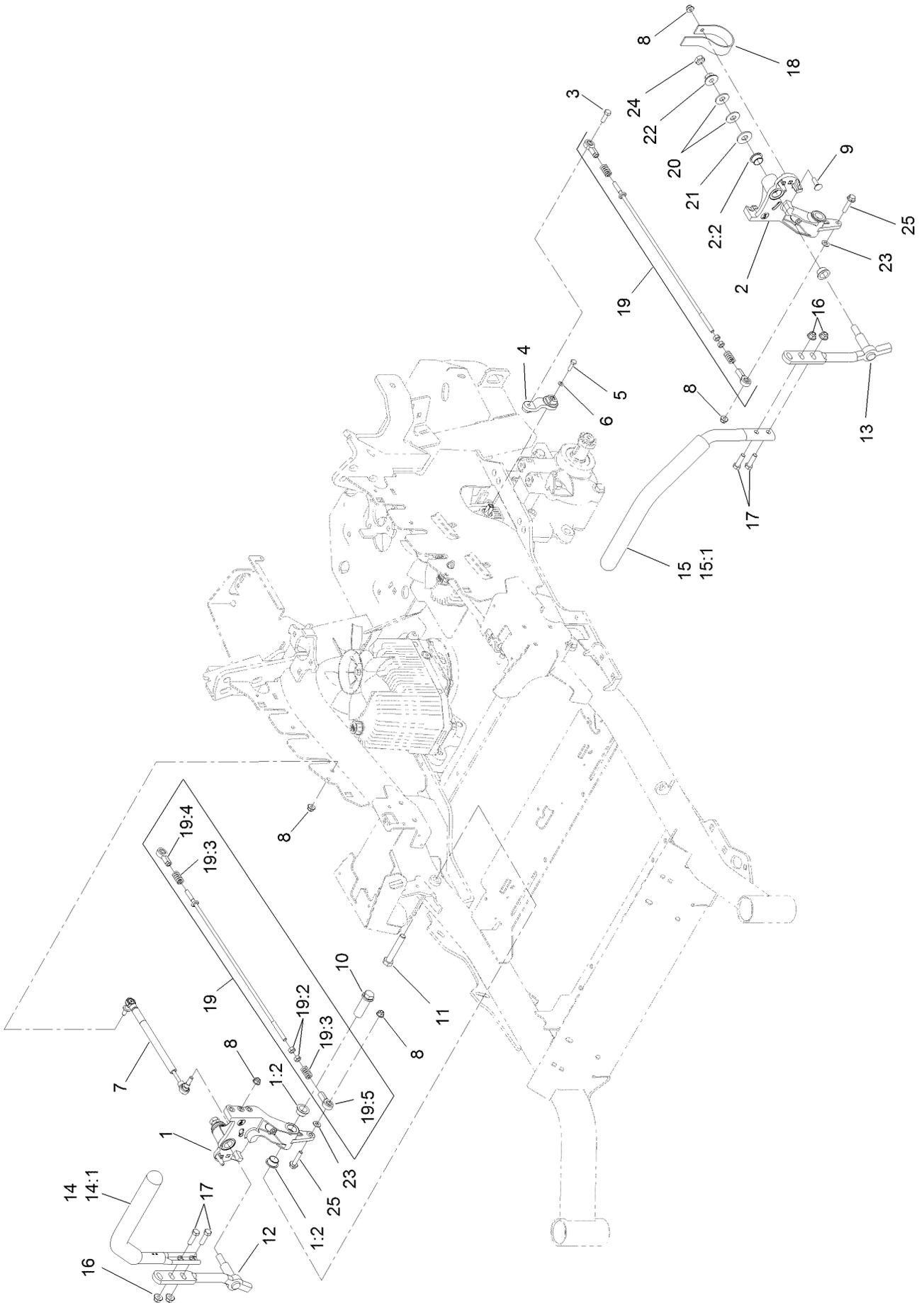

Motion Control Assembly (continued)

<i>Ref.</i>	<i>Part Number</i>	<i>Qty.</i>	<i>Description</i>	<i>Ref.</i>	<i>Part Number</i>	<i>Qty.</i>	<i>Description</i>
1	116-0880	1	RH Motion Control And Bushing ASM	14	109-6589	1	RH Steering Handle ASM
1:2	109-8054	4	Bushing-Flange	14:1	109-5668	1	Grip-Control, Lever
2	116-0881	1	LH Motion Control And Bushing ASM	15	109-6590	1	LH Steering Handle ASM
2:2	109-8054	4	Bushing-Flange	15:1	109-5668	1	Grip-Control, Lever
3	116-0648	2	Screw-HH, Thread Locking ●	16	104-8301	4	Nut-Flange, NI
4	109-4581	2	Arm-Control, Pump	17	323-7	4	Screw-HH
5	9080046	2	Screw-HH ●	18	109-5575	2	Spring-Leaf
6	1-303435	2	Washer-Spring	19	109-8107	2	Pump Linkage Rear ASM
7	116-0027	2	Damper-Control, Motion	19:2	3219-2	2	Nut-Hex
8	104-8300	8	Nut-Flange, NI	19:3	1-323245	2	Spring-Compression
9	3230-2	2	Bolt-CARR	19:4	1-633152	1	Balljoint-LH
10	109-5891	2	Hub-Threaded	19:5	1-543017	1	Balljoint-RH
11	325-12	2	Screw-HH	20	109-9505	4	Washer-Spring
12	116-0039	1	Lever-Control Motion, RH	21	3256-6	2	Washer-Flat
13	116-0040	1	Lever-Control Motion, LH	22	32128-56	2	Nut-HF
				23	3256-23	2	Washer-Flat
				24	3218-5	2	Nut-Jam
				25	115-1794	2	Screw-HHF

● Use Pro-Lock, Nut Type (P/N 1-840022, .5ml tube) on threads.

Rear Wheel Assembly

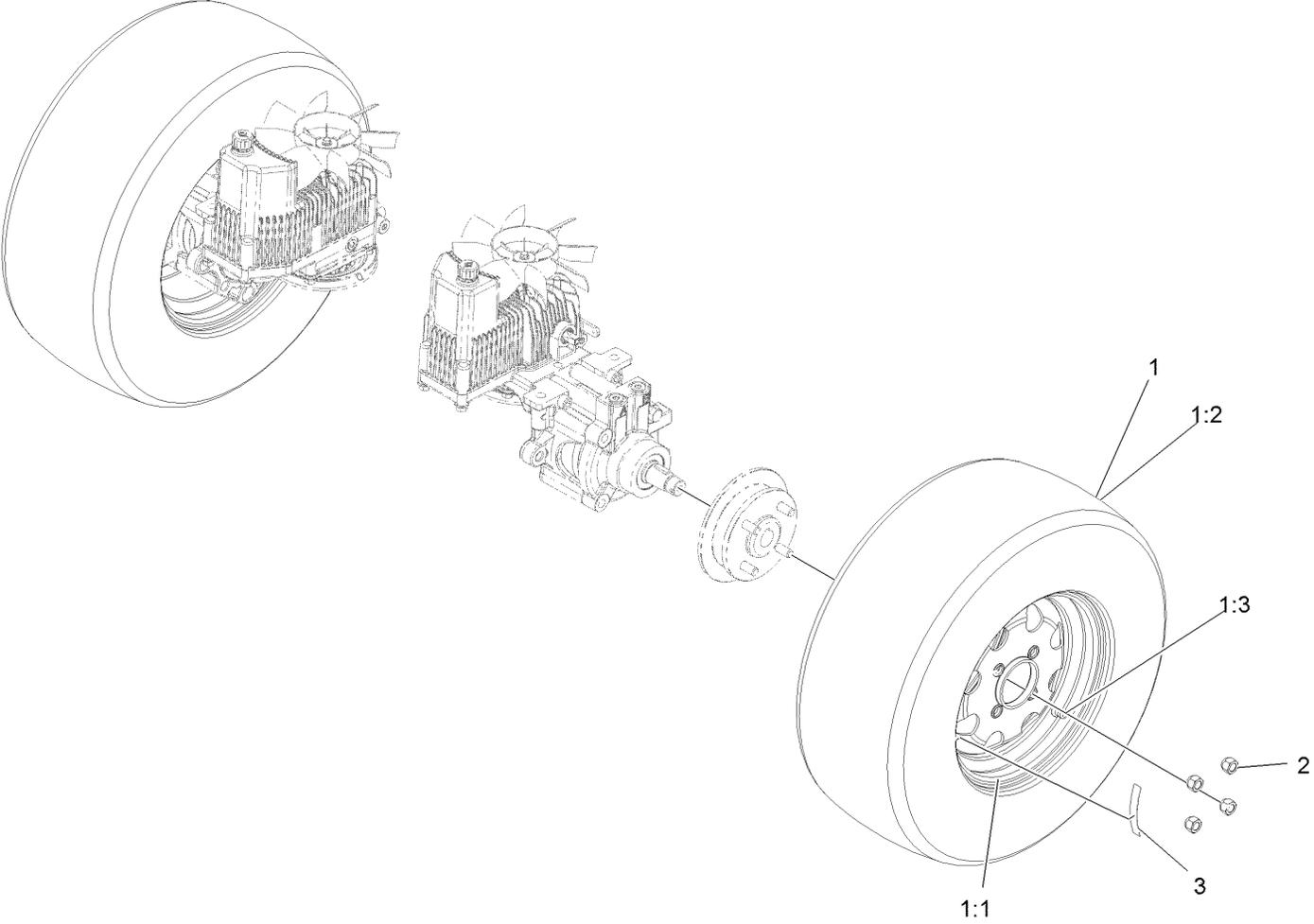

Rear Wheel Assembly (continued)

<i>Ref.</i>	<i>Part Number</i>	<i>Qty.</i>	<i>Description</i>	<i>Ref.</i>	<i>Part Number</i>	<i>Qty.</i>	<i>Description</i>
1	115-3590	2	Wheel And Tire ASM	2	242-50	8	Nut-Lug 1/2-20
1:1	109-3645	1	Rim ASM	3	126-2055	2	Decal-Torque, Wheel Hub Lug
1:2	1-653160	1	Tire				
1:3	232-27	1	Stem-Valve				

Park Brake Assembly

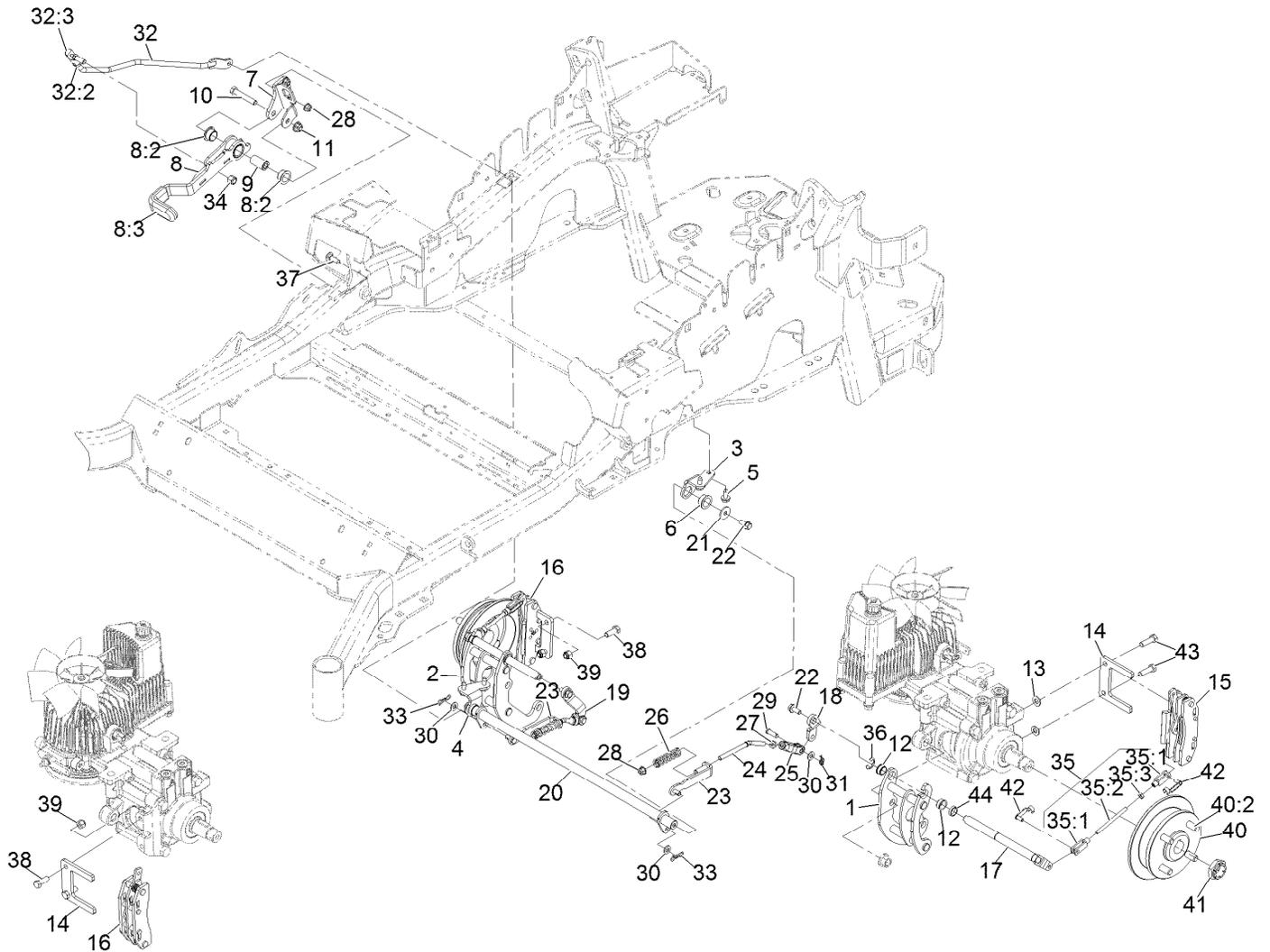

REAR VIEW OF
RIGHT HAND HYDRO

Park Brake Assembly (continued)

<i>Ref.</i>	<i>Part Number</i>	<i>Qty.</i>	<i>Description</i>	<i>Ref.</i>	<i>Part Number</i>	<i>Qty.</i>	<i>Description</i>
1	126-4248	1	Mount-Bellcrank, LH	26	116-9085	2	Spring-Compression
2	126-4249	1	Mount-Bellcrank, RH	27	3220-2	2	Nut-Jam 5/16-24
3	116-9681	1	Mount-Pivot, LH	28	104-8300	4	Nut-Nyloc 5/16-18 Flg
4	116-9682	1	Mount-Pivot, RH	29	1-808280	2	Pin-Clevis 5/16 X 1 49/64
5	32144-70	4	Screw-HWH 5/16-18 X 3/4 Tf	30	3256-23	4	Washer-5/16 Sae
6	109-8054	2	Bushing-Flanged	31	116-6639	2	Pin-Cotter, Locking
7	116-9096-01	1	Bracket-Mount	32	116-9102	1	Front Linkage ASM
8	126-0970	1	Brake Lever ASM	32:2	94-7572	1	End-Tie Rod, RH
8:2	109-8054	2	Bushing-Flanged	32:3	3220-3	1	Nut-Jam 3/8-24
8:3	1-633268	1	Grip-Lever	33	119-1415	2	Pin-Cotter, Locking
9	116-9117	1	Handle-Pivot, Brake	34	3296-6	1	Nut-Nyloc 3/8-24
10	323-11	1	Screw-HH 3/8-16 X 2 1/4	35	126-7587	2	ASM-Rear Linkage
11	104-8301	1	Nut-Nyloc 3/8-16 Flg	35:1	126-7588	2	Yoke
12	126-6199	4	Bushing-Igus	35:2	116-9069	1	Linkage, Rear
13	3256-24	2	Washer-3/8 Sae	35:3	3220-1	1	Nut-Jam 1/4-28
14	109-0958	2	Plate-Mount, Brake	36	32120-19	2	E-Ring
15	109-2889	1	Caliper-Brake	37	3230-2	2	Bolt-Carriage 5/16-18 X 1
16	116-9103	1	Caliper-Brake, RH	38	323-6	2	Screw-HH 3/8-16 X 1
17	126-4251	2	Bellcrank	39	3296-39	2	Nut-Nyloc 3/8-16
18	126-3715	1	Arm-Inner, LH	40	116-1746	2	Wheel Hub ASM
19	126-3716	1	Arm-Inner, RH	40:2	116-1696	4	Stud-Wheel
20	116-9080	1	Shaft-Cross	41	116-1399	2	Locknut
21	115-7109	2	Washer-Flat	42	126-6395	4	Pin-Clevis, Spring
22	98-9940	4	Screw	43	92-5727	2	Screw-HH 3/8-16 X 1 1/4 Patch Lock
23	116-9608	2	Bracket-L	44	126-6200	2	Spacer
24	116-9086	2	Linkage-Mid				
25	126-3693	2	Yoke-Offset				

Seat Assembly

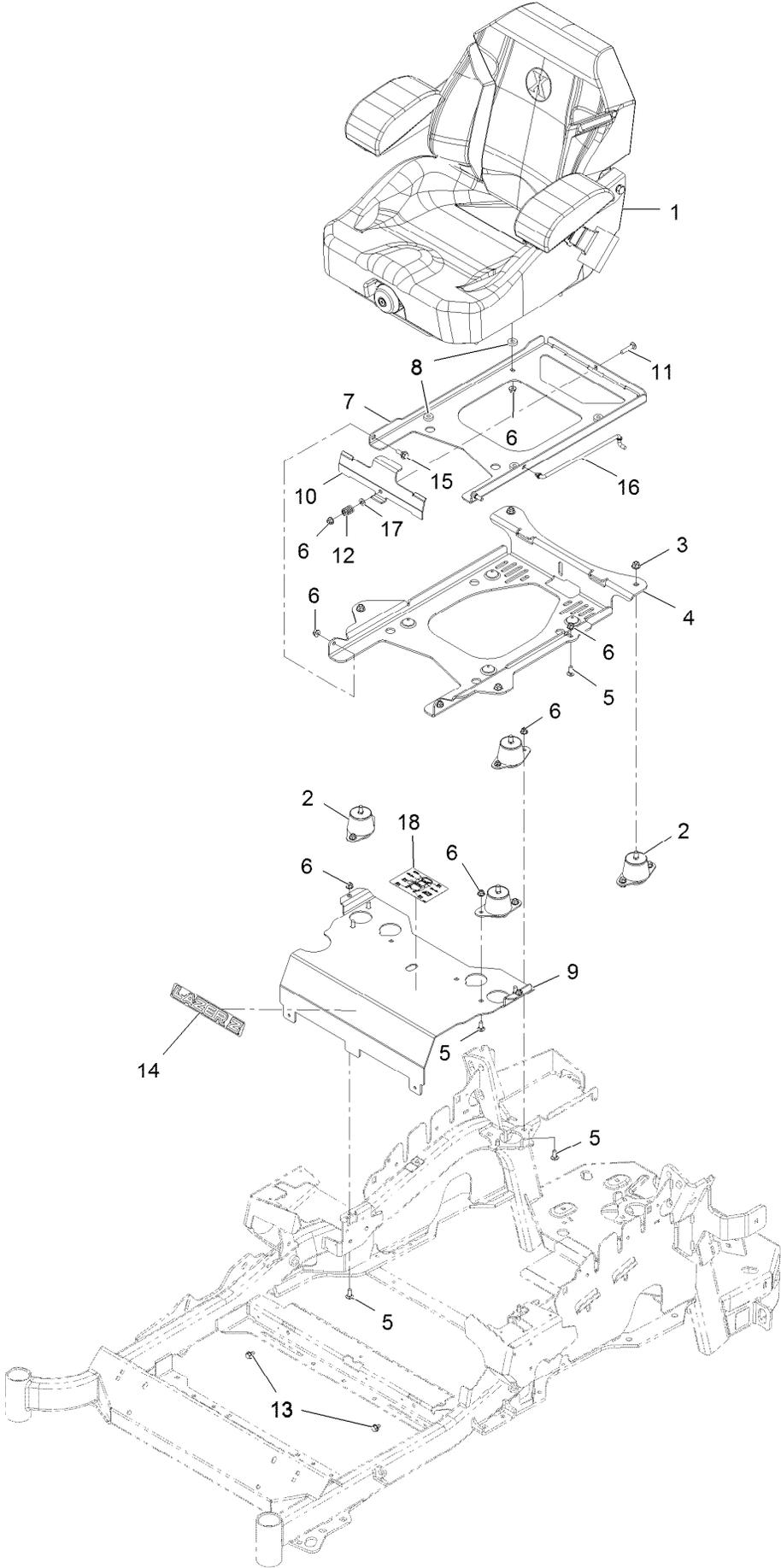

Seat Assembly (continued)

<i>Ref.</i>	<i>Part Number</i>	<i>Qty.</i>	<i>Description</i>	<i>Ref.</i>	<i>Part Number</i>	<i>Qty.</i>	<i>Description</i>
1	116-8912	1	Kit-Suspension Seat	10	109-9881-03	1	Plate-Latch, Seat
2	109-9034	4	Isolator-Seat	11	3230-4	1	Bolt-Carriage 5/16-18 X 1 1/2
3	104-8301	4	Nut-Nyloc 3/8-16 Flg	12	107-3017	1	Spring-Compression
4	116-3860-03	1	Plate-Tilt, Seat Support	13	9266934	2	Screw-HWH 5/16 X 1/2 Tf
5	3230-23	11	Bolt-Carriage 5/16-18 X 3/4 Short Neck	14	126-6574	1	Decal, Lazer Model
6	104-8300	18	Nut-Nyloc 5/16-18 Flg	15	116-1297	2	Screw-Shoulder
7	116-3859-03	1	Plate-Frame, Seat	16	116-0070	1	Rod-Prop
8	26-4840	4	Spacer-Pin, Mounting	17	3256-23	1	Washer-5/16 Sae
9	116-2130-03	1	Panel-Front, Seat Mount	18	114-4465	1	Decal-Service Aid

Seat W/Tracks Assembly No. 116-8912

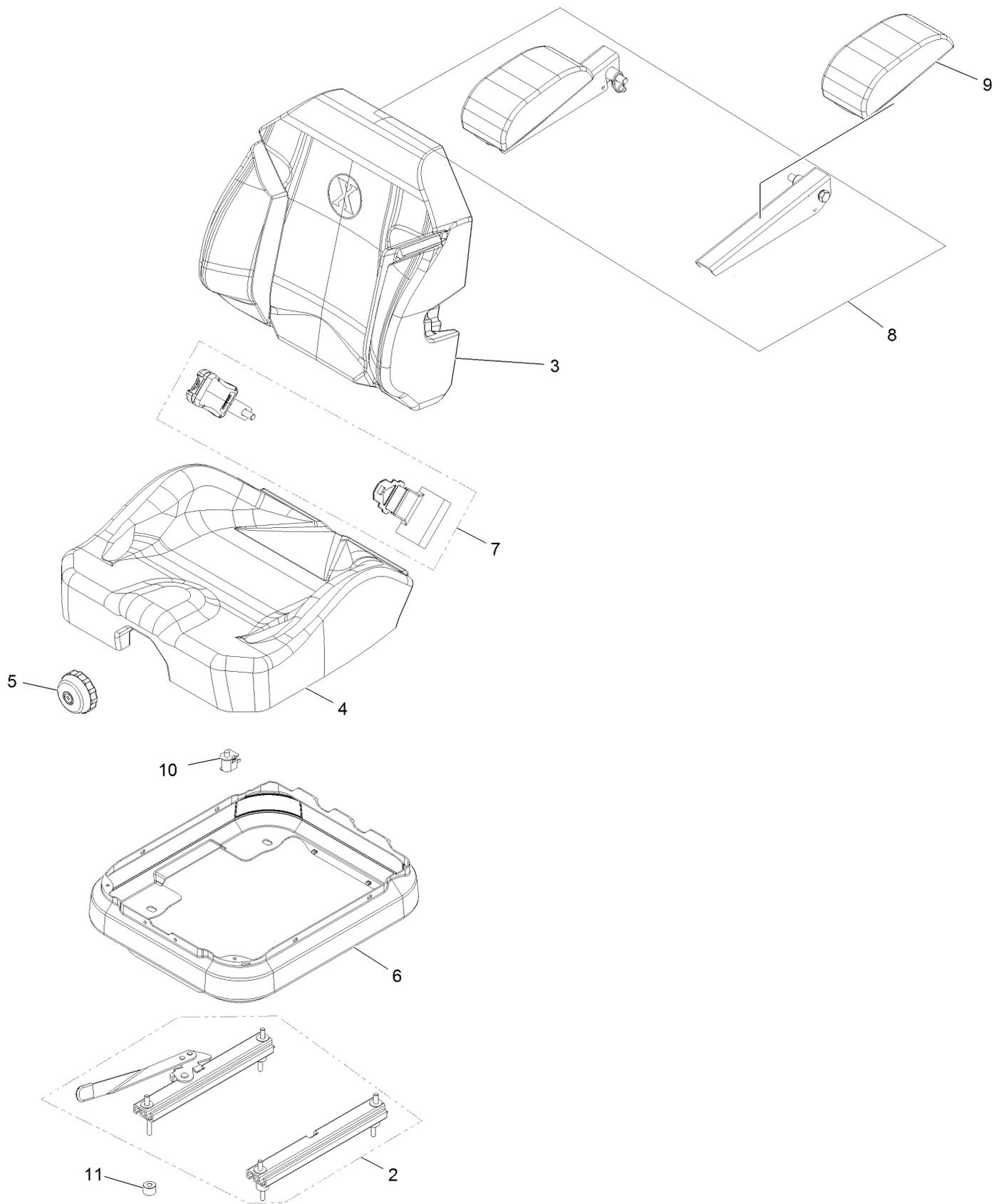

Seat W/Tracks Assembly No. 116-8912 (continued)

<i>Ref.</i>	<i>Part Number</i>	<i>Qty.</i>	<i>Description</i>	<i>Ref.</i>	<i>Part Number</i>	<i>Qty.</i>	<i>Description</i>
2	116-8910	1	Seat Track Set	7	126-2061	1	Seat Belt Service Kit
3	116-8908	1	Cover-Back 311463Vn500	8	116-8906	1	Kit-Arm Rest Set
4	116-8909	1	Cover-Cushion 311464Vn500	9	116-8905	1	Kit-Arm Rest Pads
5	116-8911	1	Knob-Adjuster	10	82-2190	1	Switch-Bail
6	116-5659	1	Cover-Suspension Bellows	11	116-9329	4	Spacer

Fuel Assembly (continued)

<i>Ref.</i>	<i>Part Number</i>	<i>Qty.</i>	<i>Description</i>	<i>Ref.</i>	<i>Part Number</i>	<i>Qty.</i>	<i>Description</i>
1	126-6494	1	ASM-12 Gal Fuel Tank, Low Perm	5	109-9491	1	Fuel Manifold Vent ASM
2	3218-1	2	Nut-Jam 1/4-20	6	98-2952	1	Fitting-Straight
3	116-6380	2	Bumper-Rubber (W/ Stud)	7	116-5087	1	Hose-Fuel
4	116-3977	1	Hose ASM	8	105-1853	1	Clamp-Hose
				9	116-6005	1	Retainer-Line, Vapor

Fuel Tank Assembly No. 126-6494

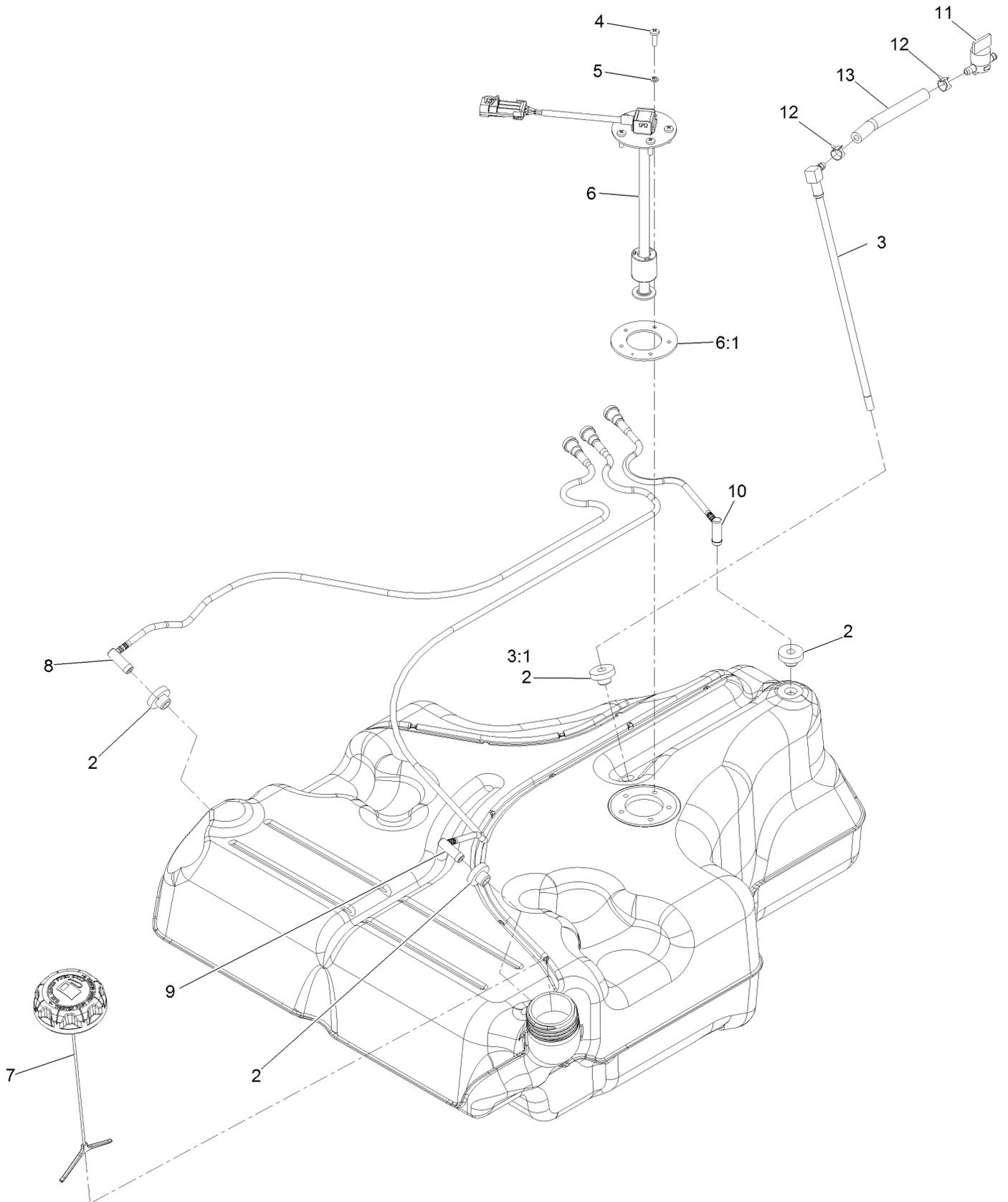

Fuel Tank Assembly No. 126-6494 (continued)

<i>Ref.</i>	<i>Part Number</i>	<i>Qty.</i>	<i>Description</i>	<i>Ref.</i>	<i>Part Number</i>	<i>Qty.</i>	<i>Description</i>
2	46-6560	4	Bushing	8	116-2460	1	RH Vent Line Kit (With Grommet)
3	116-2459	1	Fuel Line Kit (With Grommet)	9	116-2461	1	LH Vent Line Kit (With Grommet)
3:1	46-6560	1	Bushing	10	116-2462	1	Rear Vent Line Kit (With Grommet)
4	3290-500	5	Screw-PPH #10-24 X 5/8	11	1-603770	1	Valve-Fuel
5	3253-17	5	Washer-Lock 3/16	12	2412-98	2	Clamp-Hose
6	126-3913	1	Sender-Fuel, Float - 12 Gal	13	109-0650	1	Hose-Fuel
6:1	126-3950	1	Gasket-Sender				
7	126-1789	1	Cap-Fuel, Ratcheting				

Engine Assembly

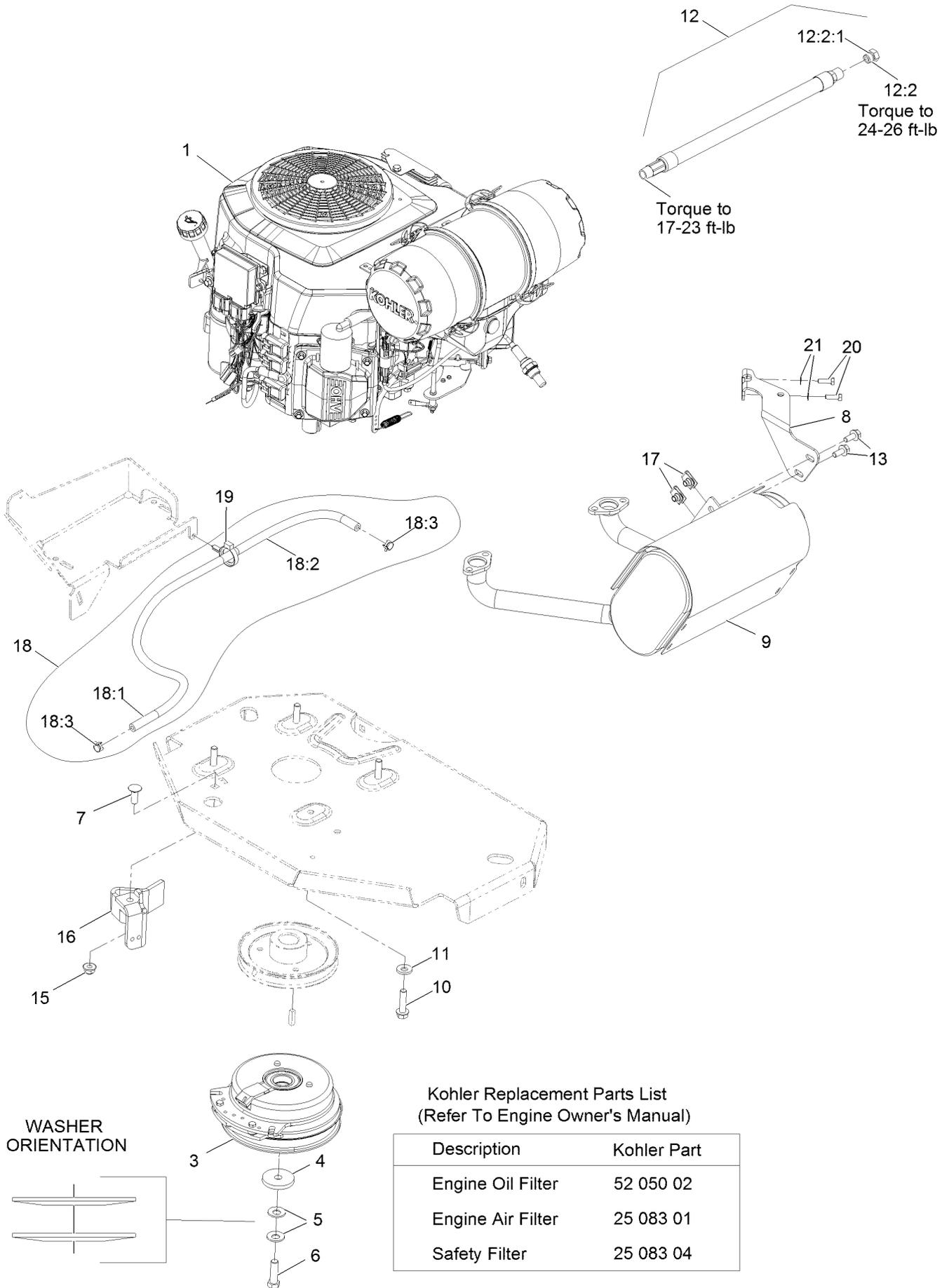

Kohler Replacement Parts List
(Refer To Engine Owner's Manual)

Description	Kohler Part
Engine Oil Filter	52 050 02
Engine Air Filter	25 083 01
Safety Filter	25 083 04

Engine Assembly (continued)

<i>Ref.</i>	<i>Part Number</i>	<i>Qty.</i>	<i>Description</i>	<i>Ref.</i>	<i>Part Number</i>	<i>Qty.</i>	<i>Description</i>
1		1	Engine - Kohler Ecv740-3039 W/E-Gov ●■	12:2	353-508	1	Plug-W/O-Ring
				12:2:1	237-42	1	O-Ring
3	116-1620	1	Clutch Kit	13	3234-5	2	Screw-HH Flg 5/16-18 X 3/4
4	109-6919	1	Washer-Clutch	15	104-8301	1	Nut-Nyloc 3/8-16 Flg
5	1-603610	2	Washer-Spring Disc 7/16	16	116-2612-01	1	Clutch-Anchor
6	109-9761	1	Screw-HH 7/16-20 X 1 1/2 W/Loctite ▲	17	94-2413	2	Nut-U
7	3231-22	1	Bolt-Carriage 3/8-16 X 1	18	117-3893	1	Fuel Line ASM
8	116-4297	1	Muffler Bracket Kit	18:1	109-0273	1	Hose-Fuel Line 38 1/4"
9	116-2038	1	Muffler	18:2	117-3892	1	Sleeve-Thermal
10	32144-102	4	Screw-HWH 3/8-16 X 1 1/2 Taptite	18:3	2412-98	2	Clamp-Hose
11	98-5975	4	Washer-Spring Disc 3/8	19	104-2490	1	Clamp-Hose
12	116-5316	1	Oil Drain Hose ASM	20	116-4295	2	Screw-HH M6-1 X 20Mm W/Patch
				21	1-303435	2	Washer-Spring Disc 1/4

● Not serviced separately

▲ Use Pro-Lock, Nut Type (P/N 1-840022, .5ml tube) on threads.

■ Obtain parts from www.kohlerplus.com

Hydraulic Assembly

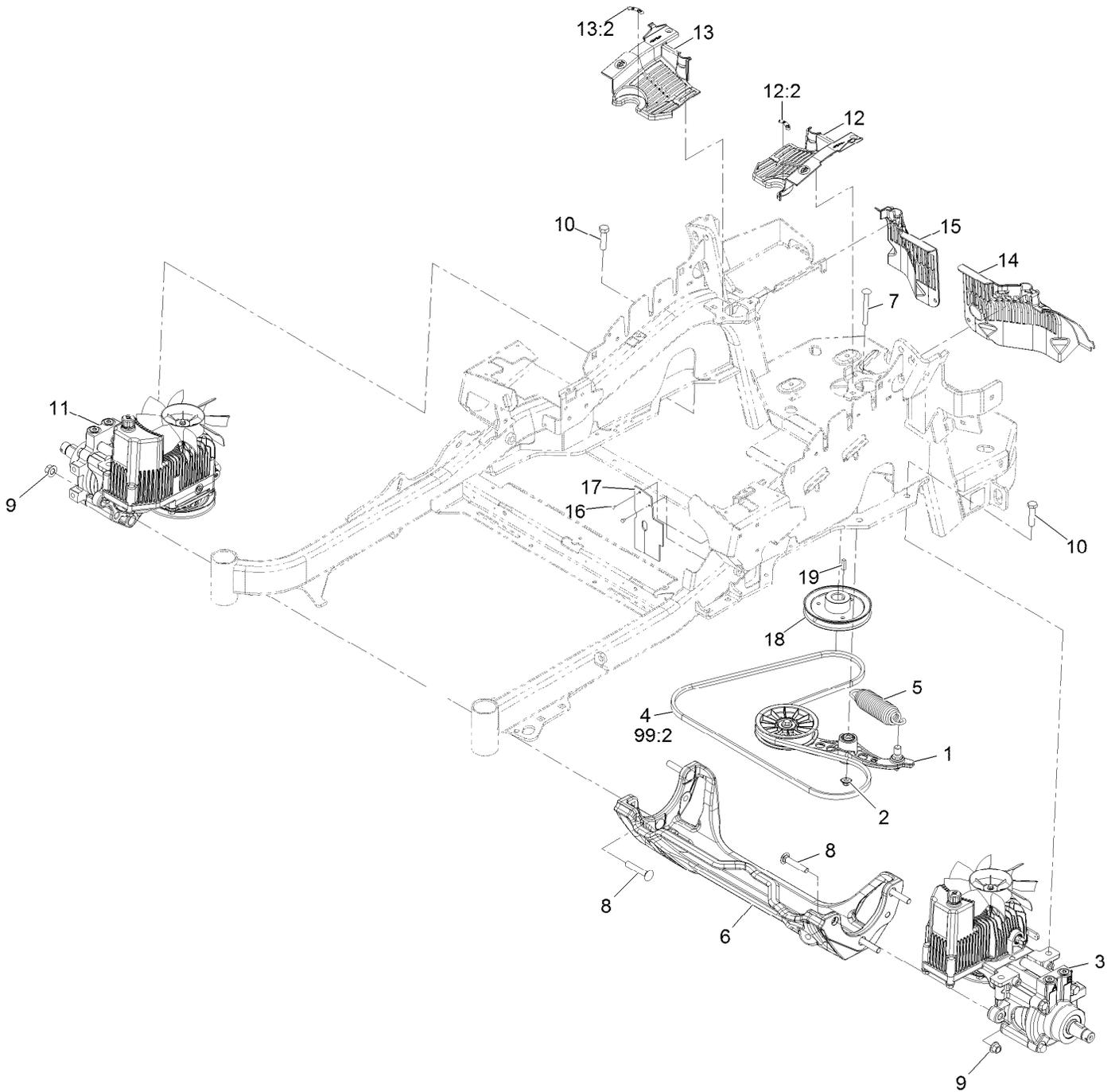

Hydraulic Assembly (continued)

<i>Ref.</i>	<i>Part Number</i>	<i>Qty.</i>	<i>Description</i>	<i>Ref.</i>	<i>Part Number</i>	<i>Qty.</i>	<i>Description</i>
1	116-1255	1	Pump Idler ASM	13	116-0171	1	RH Hydro Guard ASM
2	109-6658	1	Nut-Nyloc 3/8-16 Flg	13:2	116-8726	1	Decal-Oil, Hydro
3	126-1321	1	LH Hydro ASM (12Cc W/ Check)	14	109-9057	1	Guard-Hydro, Rear (LH)
4	109-3388	1	Belt	15	109-9058	1	Guard-Hydro, Rear (RH)
5	116-6317	1	Spring-Extension	16	1-803035	2	Rivet 3/16 X 1/4
6	116-7558	1	Cradle-Hydro	17	116-2362	1	Deflector-Air Flow
7	116-1502	1	Bolt-Carriage Shoulder 3/8-16 X 3 1/2	18	109-9905	1	Sheave
8	126-0095	6	Screw-CARR	19	1-807259	1	Key
9	99-5107	6	Nut-Lock 1/2-13	99	109-9828	1	Bottle-Oil, 32Oz Hydraulic ●
10	325-8	4	Screw-HH 1/2-13 X 1 1/4	99	116-0164	1	Filter-Hydro ●
11	126-1322	1	RH Hydro ASM (12Cc W/ Check)	99	116-1218	1	Bottle,Oil 1 Gallon Hydraulic ●
12	116-0170	1	LH Hydro Guard ASM	99	116-3270	1	Kit, Hydro Service ●
12:2	116-8726	1	Decal-Oil, Hydro	99:1	109-9828	4	Bottle-Oil, 32Oz Hydraulic ●
				99:2	109-3388	1	Belt
				99:3	116-0164	2	Filter-Hydro ●

● Not illustrated

LH Hydro Assembly No. 126-1321

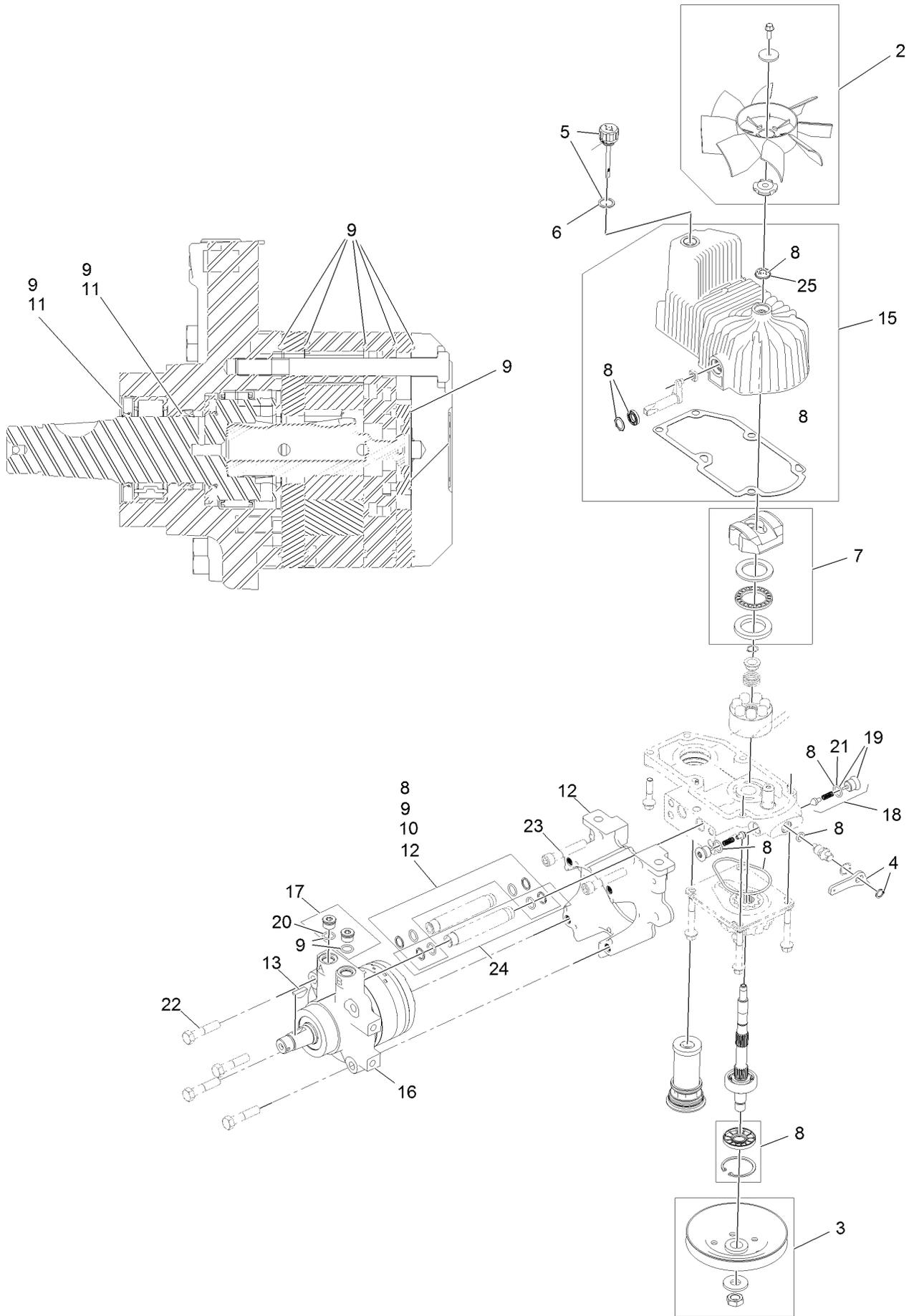

LH Hydro Assembly No. 126-1321 (continued)

<i>Ref.</i>	<i>Part Number</i>	<i>Qty.</i>	<i>Description</i>	<i>Ref.</i>	<i>Part Number</i>	<i>Qty.</i>	<i>Description</i>
2	116-0233	1	Fan Kit	15	116-3287	1	Housing-LH
3	116-0234	1	Pulley Kit	16	116-8915	1	Motor-Hydraulic LH 240Cc
4	116-0235	1	Handle-Bypass Valve, Hydro	17	116-7901	1	Magnetic Plugs Service Kit
5	116-0236	1	Dipstick-Hydro W/Gasket	18	116-1630	2	Check Valve ASM
6	116-0237	1	Gasket-Dipstick, Hydro	19	116-1631	2	Plug-Check (W/O-Ring)
7	116-1367	1	Swash Block Kit	20	76-1900	2	O-Ring
8	116-1368	1	Pump Seal Kit	21	116-8662	2	O-Ring-Check Valve
9	116-1369	1	Motor Seal Kit	22	116-8974	4	Screw-HH 1/2-20 X 2 1/4
10	116-1370	1	Tube Seal Kit	23	116-8975	2	Screw-HSH 1/2-20 X 2 3/4
11	116-1371	1	Output Shaft Seal Kit	24	116-9922	2	Hydraulic Tube Kit
12	116-5469	1	Nose Cup-Uht	25	126-7711	1	Seal-Fan Drive
13	3257-42	1	Key-Woodruff 5/16 X 1	99	116-1373	1	Flow Test Kit ●
				99	116-4245	1	Puller-Pulley Uht ●

● Not illustrated

RH Hydro Assembly No. 126-1322

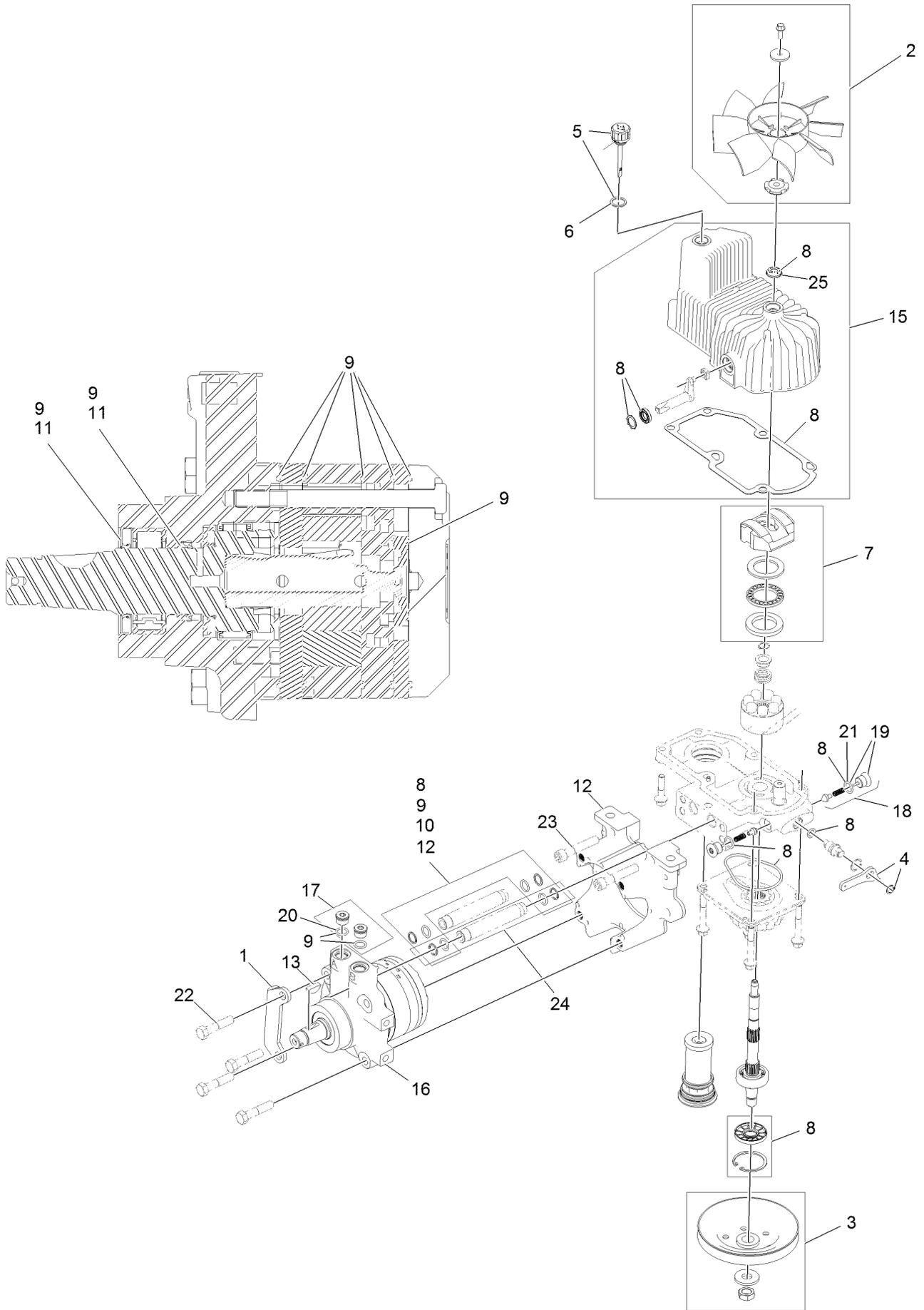

RH Hydro Assembly No. 126-1322 (continued)

<i>Ref.</i>	<i>Part Number</i>	<i>Qty.</i>	<i>Description</i>	<i>Ref.</i>	<i>Part Number</i>	<i>Qty.</i>	<i>Description</i>
1	116-9063	1	Mount-Shoe, Horse	15	116-3288	1	Housing-RH
2	116-0233	1	Fan Kit	16	116-8916	1	Motor-Hydraulic RH 240Cc
3	116-0234	1	Pulley Kit	17	116-7901	1	Magnetic Plugs Service Kit
4	116-0235	1	Handle-Bypass Valve, Hydro	18	116-1630	2	Check Valve ASM
5	116-0236	1	Dipstick-Hydro W/Gasket	19	116-1631	2	Plug-Check (W/O-Ring)
6	116-0237	1	Gasket-Dipstick, Hydro	20	76-1900	2	O-Ring
7	116-1367	1	Swash Block Kit	21	116-8662	2	O-Ring-Check Valve
8	116-1368	1	Pump Seal Kit	22	116-8974	4	Screw-HH 1/2-20 X 2 1/4
9	116-1369	1	Motor Seal Kit	23	116-8975	2	Screw-HSH 1/2-20 X 2 3/4
10	116-1370	1	Tube Seal Kit	24	116-9922	2	Hydraulic Tube Kit
11	116-1371	1	Output Shaft Seal Kit	25	126-7711	1	Seal-Fan Drive
12	116-5469	1	Nose Cup-Uht	99	116-1373	1	Flow Test Kit ●
13	3257-42	1	Key-Woodruff 5/16 X 1	99	116-4245	1	Puller-Pulley Uht ●

● Not illustrated

Pump Idler Assembly No. 116-1255

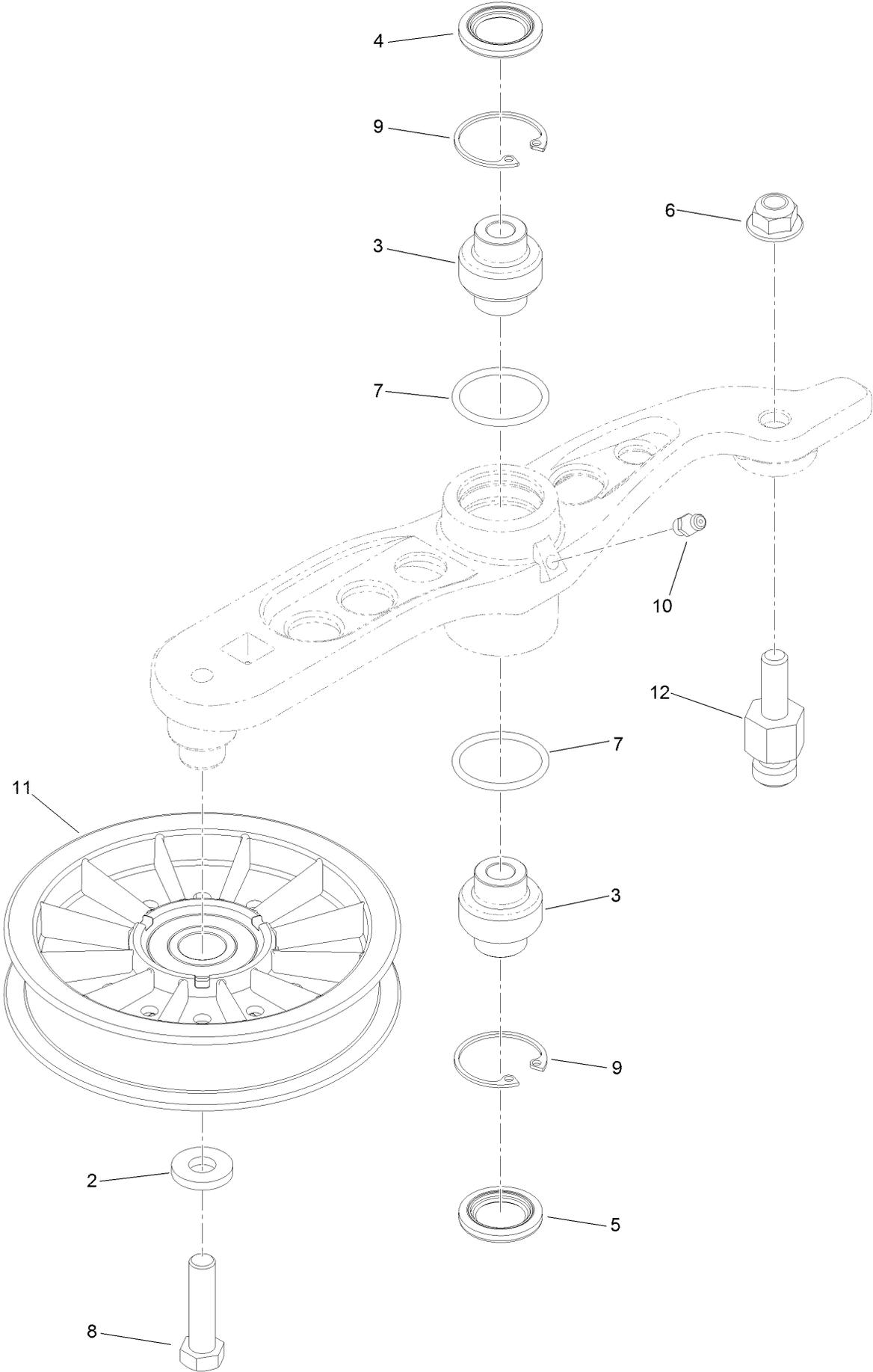

Pump Idler Assembly No. 116-1255 (continued)

<i>Ref.</i>	<i>Part Number</i>	<i>Qty.</i>	<i>Description</i>	<i>Ref.</i>	<i>Part Number</i>	<i>Qty.</i>	<i>Description</i>
2	43-0940	1	Spacer	8	323-8	1	Screw-HH
3	103-3504	2	Bearing-Spherical	9	32120-10	2	Ring-Snap
4	103-3505	1	Seal-Double Lip	10	302-19	1	Fitting-Grease
5	103-3506	1	Seal-Lip, Single	11	109-8076	1	Pulley-Idler
6	109-6658	1	Nut-Flange, NI	12	116-3467	1	Pin-Spring, Anchor
7	106-7159	2	O-Ring				

Electrical Assembly

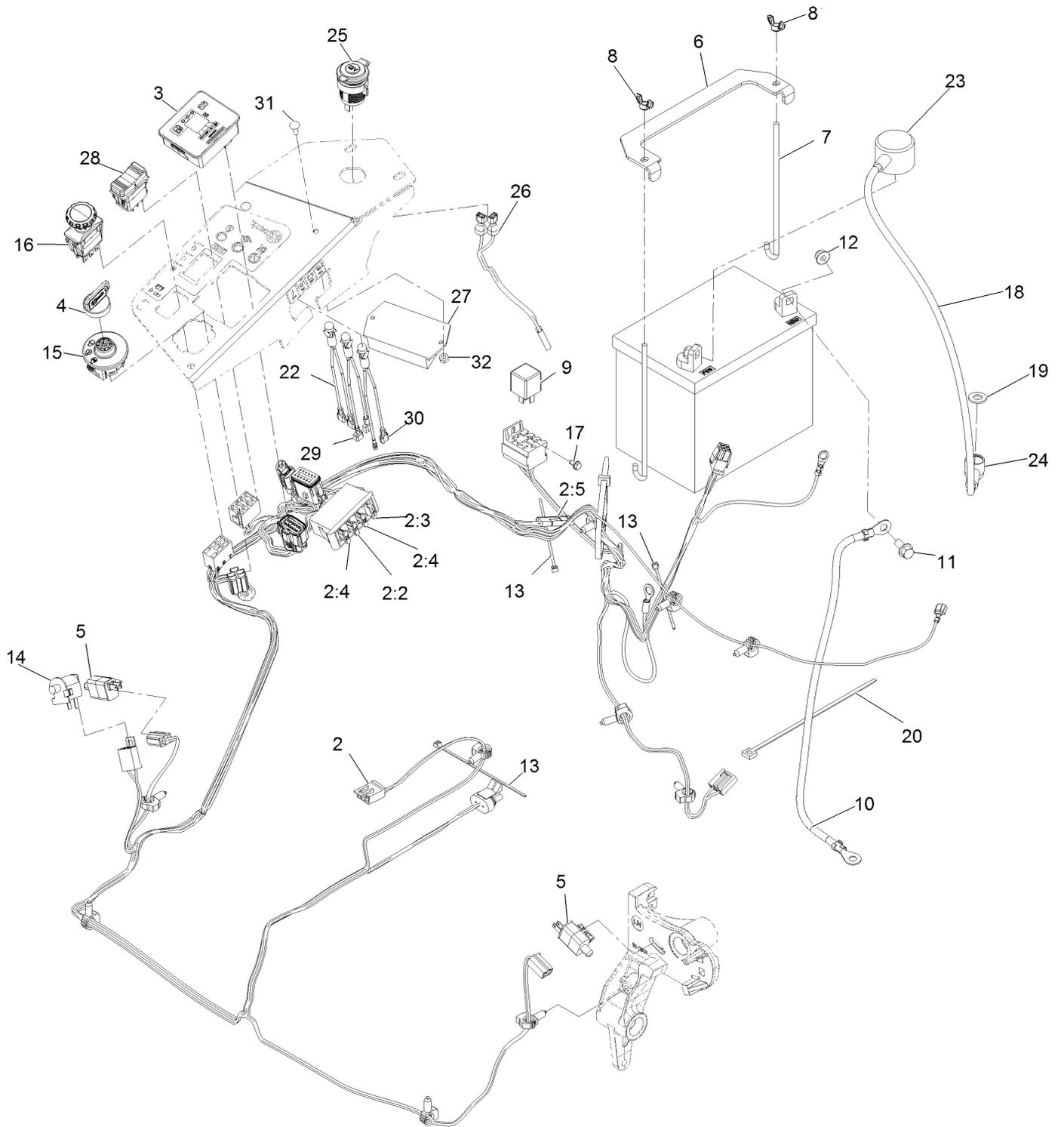

Electrical Assembly (continued)

<i>Ref.</i>	<i>Part Number</i>	<i>Qty.</i>	<i>Description</i>	<i>Ref.</i>	<i>Part Number</i>	<i>Qty.</i>	<i>Description</i>
2	126-1682	1	Harness-Wire ●	15	117-2221	1	Switch-Ignition
2:2	218-578	1	Fuse-Blade, 10 Amp	16	116-0124	1	Switch-PTO, 10A
2:3	109355	1	Fuse-Blade, 15 Amp	17	104-2065	1	Screw-HWH #10-24 X 3/8
2:4	109102	2	Fuse-Blade, 25 Amp	18	115-3864	1	Cable-Battery, Positive
2:5	116-0053	1	Cap-Plug	19	3256-24	1	Washer-3/8 Sae
3	117-3882	1	Fuel/Hour Meter ASM	20	1-303335	1	Tie-Cable 7 15/16 (Large)
4	1-603511	1	Key-Ignition	22	1-643267	1	Indicator-Red Led
4	103-2106	1	Key-Exmark Logo	23	109-2407	1	Insulator-Battery
5	110-6765	2	Switch	24	1-543393	1	Insulator-Solenoid
6	116-0042-03	1	Strap-Tie Down, Battery	25	109-9376	1	Receptacle-12V
7	1-633651	2	Bolt-Holddown	26	109-9693	1	Harness, Receptacle 12V
8	1-543792	2	Wingnut-Nyloc 1/4-20	27	126-2722	1	Controller-Red
9	1-643275	1	Relay-12Vdc 40 Amp	28	116-9669	1	Switch-Rocker
10	114-1218	1	Cable-Battery, Negative	29	116-9651	1	Light-Led, Red
11	3234-5	2	Screw-HH Flg 5/16-18 X 3/4	30	116-9652	1	Light-Led, Red
12	104-8300	2	Nut-Nyloc 5/16-18 Flg	31	3229-34	2	Screw-CARR
13	1-303287	3	Tie-Cable 5 1/2 (Small)	32	3296-2	2	Nut-Nyloc #10-24
14	82-2190	1	Switch				

● Use dielectric grease on all unsealed connectors and terminals only. Do not apply in sealed connectors.

Notes:



MAXIMIZE THE PERFORMANCE OF YOUR EXMARK MACHINE.



EXMARK® PREMIUM ENGINE OIL

Exmark now offers a family of engine oil viscosities to perform well in any environment. Each viscosity has the same synthetic formulation to give you what you need in punishing conditions. We designed each grade to the highest quality, making it ideal even for diesel applications. Coupled with Exmark Premium Fuel Treatment, we have the performance products to make your machine hum.

EXMARK PREMIUM ENGINE OIL SAE 30/10W-30

- Meets zero shear requirements of a straight grade SAE 30 as well as the cold temp properties of a 10W-30.
- Most versatile oil in the industry.
- Superior corrosion protection over conventional oil - even in corrosive, humid environments.

EXMARK PREMIUM ENGINE OIL SAE 20W-50

- Perfect for your big block engine, or any application in severe service.
- Same full synthetic formulation as all other Exmark Premium viscosities.
- Also effective for use in severe service small block engines.

EXMARK PREMIUM ENGINE OIL SAE 10W-50

- Full synthetic formulation gives you peak performance. Don't settle for less.
- Wide span multi-grade combines easy starting in cold weather with maximum protection in high temperature operation.
- Reduce friction & wear over standard mineral formulations.

EXMARK PREMIUM ENGINE OIL SAE 0W-40

- The perfect choice for when the weather turns cold or unpredictable, and your Exmark UTV has to perform.
- Commercial quality for severe service.
- Advanced additive package helps prevent corrosion from long-term storage.

EXMARK PREMIUM ENGINE OIL UTV FORMULATION

- 4-cycle high-temp formulation.
- Heavier viscosity, full synthetic, perfect for your UTV.

EXMARK PREMIUM UTV EXTREME CONDITIONS GEAR OIL

- SAE 80W-90, designed to keep your UTV performing at its peak.
- Shear stable, hypoid gear lube.
- Includes a premium additive system to combat wear, oxidation, rust & corrosion.

Available from your local Exmark dealer. Find your closest dealer at exmark.com

EXMARK ACCESSORIES AND OPTIONS*

MID-MOUNT RIDING ACCESSORIES AND OPTIONS

CUSTOM RIDE SEAT SUSPENSION SYSTEM	OPERATOR CONTROLLED DISCHARGE
FULL SUSPENSION SEAT	SUN SHADE
DECK LIFT ASSIST KIT	TRASH CONTAINER
HITCH KIT	TURF STRIPER
LIGHT KIT	ULTRA VAC COLLECTION SYSTEM
12V POWER PORT	ULTRA VAC QUICK DISPOSAL SYSTEM
MICRO-MULCH SYSTEM	

OUT-FRONT RIDING ACCESSORIES AND OPTIONS

CUSTOM RIDE SEAT SUSPENSION SYSTEM	SNOW BLADE
DUAL-TAIL WHEEL	SNOWBLOWER
FLOOR PAN EXTENDER	SUN SHADE
HITCH KIT	TRASH CONTAINER
LIGHT KIT	ULTRA VAC COLLECTION SYSTEM
MICRO-MULCH SYSTEM	ULTRA VAC QUICK DISPOSAL SYSTEM
ROLL OVER PROTECTION SYSTEM (ROPS)	WEATHER CAB

WALK-BEHIND ACCESSORIES AND OPTIONS

GRASS CATCHER	TURF STRIPER
MICRO-MULCH SYSTEM	STANDON

*Some accessories and options not available for some models.

Place Model No. and Serial No.
Label Here (Included in the Literature
Pack) or Fill in Below

Model No. _____

Serial No. _____

Date Purchased _____

Engine Model No. and Spec. No. _____

Engine Serial No. (E/No) _____

© 2015 Exmark Mfg. Co., Inc.
Industrial Park Box 808
Beatrice, NE 68310
All Rights Reserved

Part No. 4502-700 Rev. A
(402) 223-6300
Fax (402) 223-5489
Printed in the USA.

