

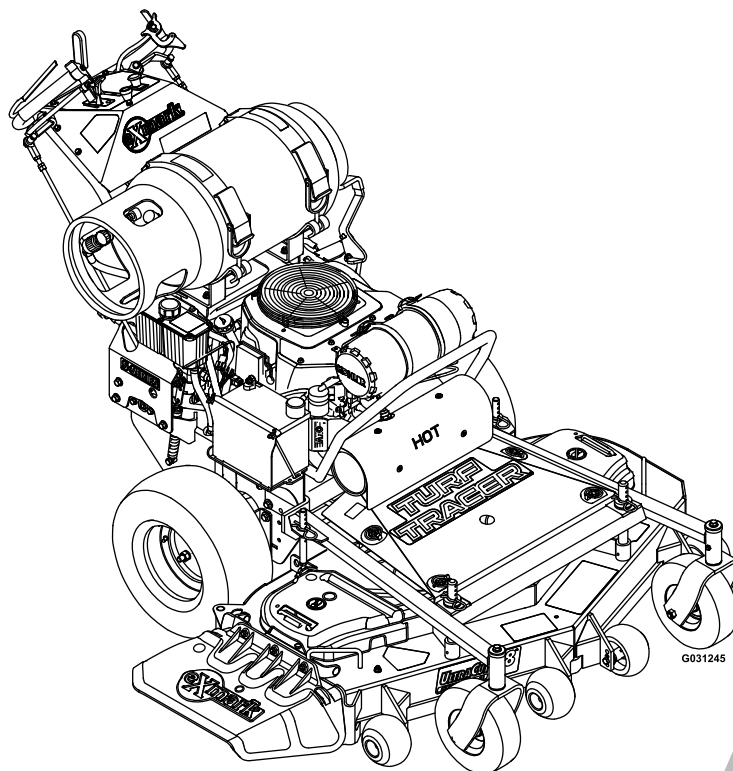

TURF TRACER S-SERIES LP

Model No. TTS680PKC483E0—Serial No. 31600000 and Up

Picture below may not reflect actual product.



Parts Manual

Part No. 4502-584 Rev. A

Ordering Replacement Parts

To order replacement parts, please supply the part number, the quantity, and the description of each part desired.

Understanding Reference Numbers

Each identified part in an illustration has a reference number. The reference number for a part also appears in the parts list, along with other information about the part.

This catalog uses two special reference number formats, one to indicate parts in a service assembly and another to indicate the quantity of a given part in an illustration.

Service Assembly Reference Numbers

Parts in service assemblies have reference numbers in the form a:b. The a represents the reference number of the entire service assembly and the b represents a sequential number unique to each part within the service assembly.

For example, a wheel assembly might be identified by reference number 6, the tire by 6:1, the valve by 6:2, and the wheel by 6:3. When you order the assembly identified by reference number 6, you receive all parts identified by reference numbers 6:1, 6:2, and 6:3. However, you may also order any part individually. Reference numbers of this type appear in illustration and in parts lists.

Reference Numbers Indicating Quantity

In an illustration, if a reference number indicates more than one part, the reference number has the form nX y. The n represents the quantity of the part, the X is the multiplication symbol, and the y represents the reference number.

For example, in an illustration, the reference number 2X 37 means that two of the parts identified by reference number 37 are indicated.

List of Abbreviations

AR: as required	HLH: hex lag head	PTH: phillips truss head
ASM: assembly	HOC: height-of-cut	PTO: power-take-off
BBC: blade brake control	HP: high pressure	RH: right hand
BHTF: button head thread forming	HSBH: hex socket button head	ROPS: roll-over protection system
CARR: carriage	HSFH: hex socket flat head	RRB: rear roller brush
CCW: counter clockwise	HSH: hex socket head	SFH: slotted fillister head
CW: clockwise	HWH: hex washer head	SHH: slotted hex head
DEG: degrees	HWHTF: hex washer head thread forming	SHWH: slotted hex washer head
DPA: Dual Point Adjustment	HYD: hydraulic	SPH: slotted pan head
ECM: electronic control module	LH: left hand	SQH: square head
EXT: external	LP: low pressure	SRH: slotted round head
FH: flat head	LPG: Liquefied Petroleum Gas	STD: standard
GA: gauge	NI: nylon insert	TAP: self tapping
HD: heavy-duty	NPTF: national pipe thread fine	TTH: torx truss head
HF: hex flange	PFH: phillips flat head	
HH: hex head	PPH: phillips pan head	
HHF: hex head flange	PPHTF: phillips pan head thread forming	
HHFTF: hex head flange thread forming	PRH: phillips round head	
HJ: hex jam		

Touch Up Paint

Exmark black touch up spray paint – gloss black.

Exmark red touch up paint (spray paint – P/N 1-850337 - .6 oz liquid bottle – P/N 103-9140).



If your Exmark dealer does not have the Exmark part in stock, Exmark will get the parts to the dealer the next business day or the part will be FREE Guaranteed!! (Some restrictions apply. See your participating Exmark Dealer for details.)

Contents

Complete Deck Assembly.....	4
Deck Assembly.....	6
Deck W/Decals Assembly No. 126-0781.....	8
Deck Idler Assembly No. 126-2314.....	10
Main Frame Assembly.....	12
Engine Deck.....	14
Handle Assembly.....	16
Controls Assembly.....	18
Fuel Assembly.....	20
Engine Assembly.....	22
Ground Drive Assembly.....	24
Pump Idler Assembly No. 126-0615.....	26
Electrical Assembly.....	28

Complete Deck Assembly

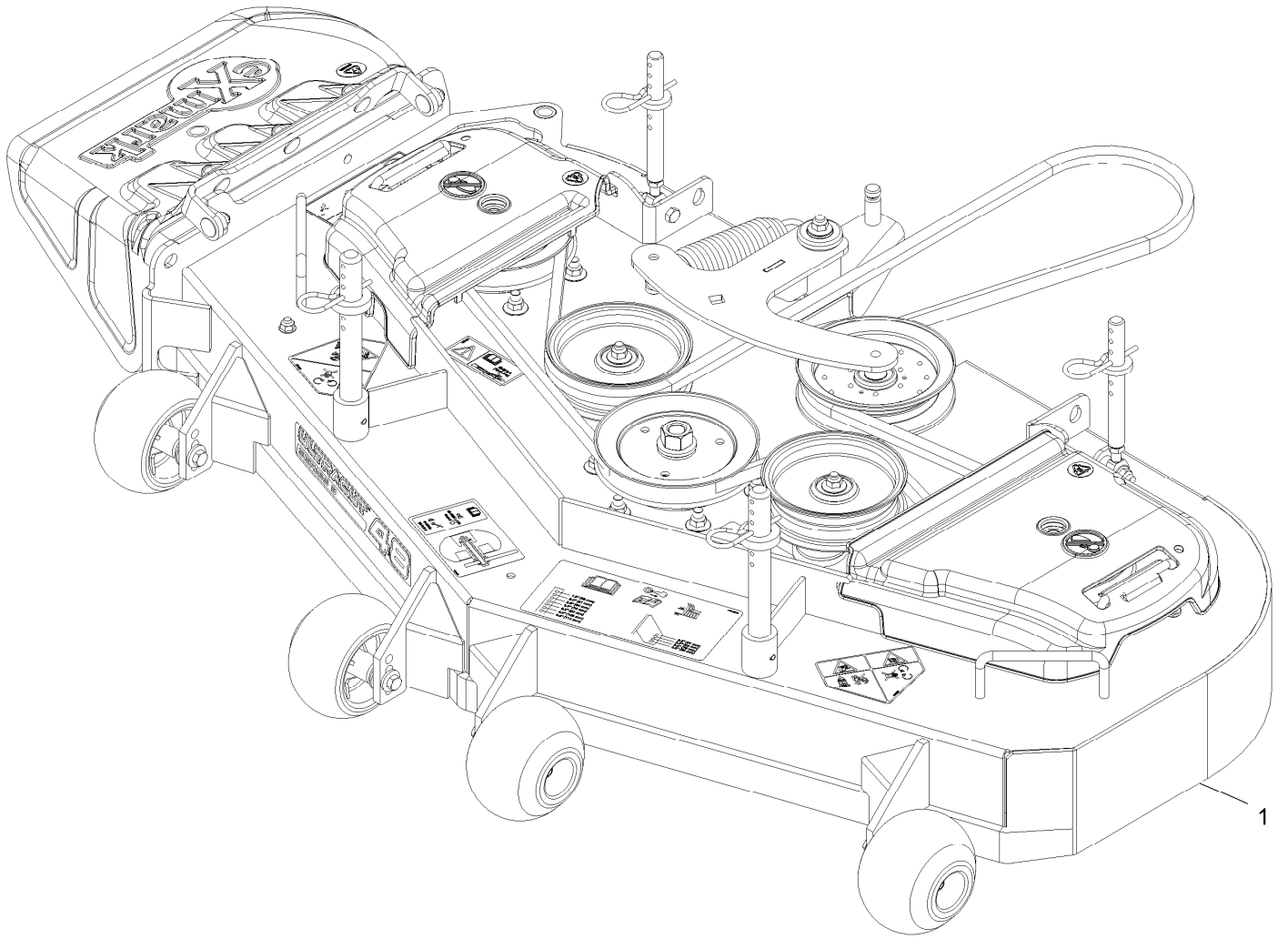

Complete Deck Assembly (continued)

<i>Ref.</i>	<i>Part Number</i>	<i>Qty.</i>	<i>Description</i>
1	126-1909	1	ASM-Complete Deck 48

Deck Assembly

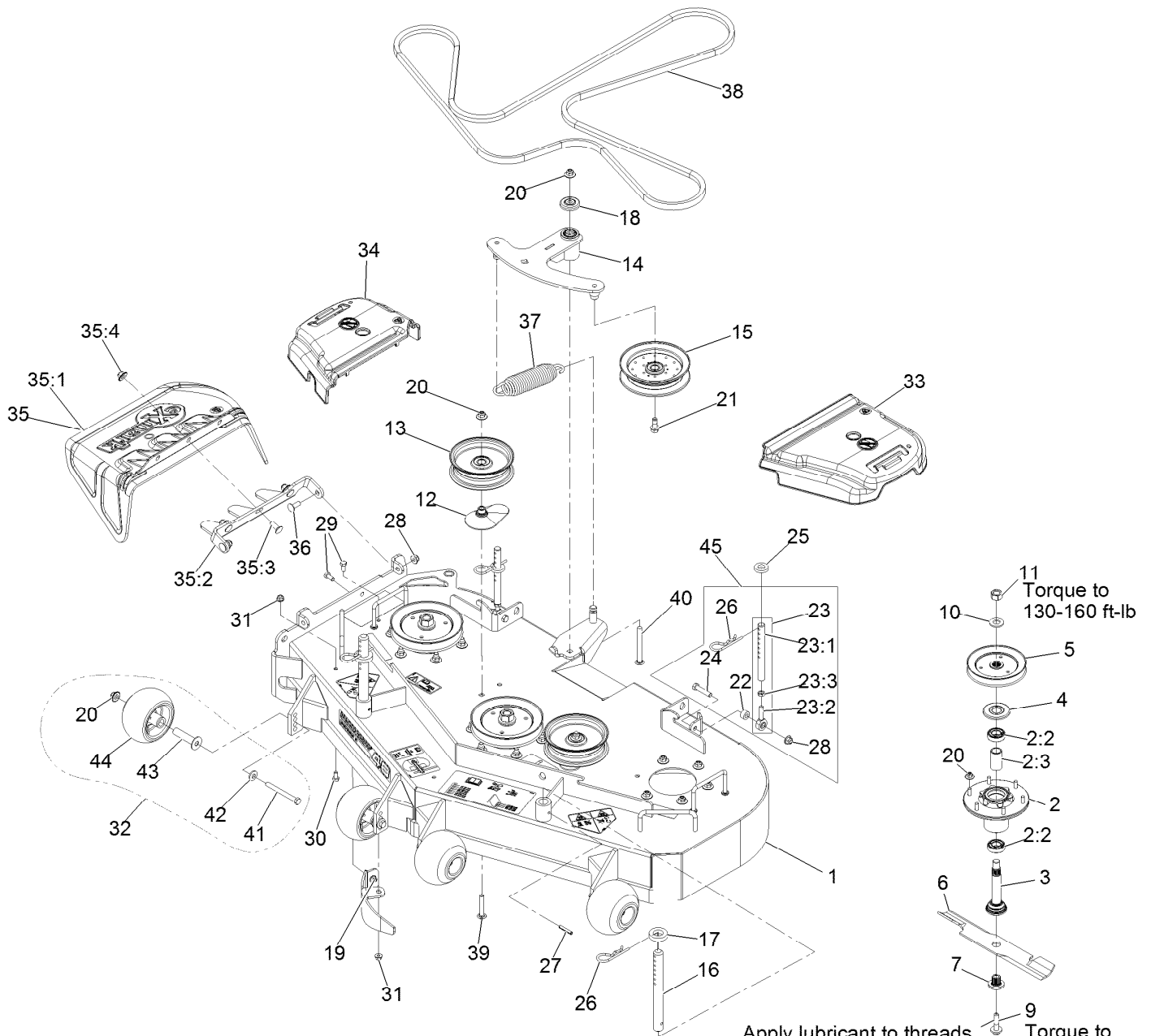

Apply lubricant to threads as needed to prevent seizing. 50-60 ft-lb
 Copper based anti-seize preferable. Grease is an acceptable substitute.

Deck Assembly (continued)

<i>Ref.</i>	<i>Part Number</i>	<i>Qty.</i>	<i>Description</i>	<i>Ref.</i>	<i>Part Number</i>	<i>Qty.</i>	<i>Description</i>
1	126-0781	1	ASM, Deck 48" W/Decals	23:2	1-613204	1	Balljoint
2	116-3344	3	ASM-Cutter Hsg With Bearings	23:3	3220-3	1	Nut-Jam 3/8-24
2:2	116-0720	2	Bearing-Ball	24	323-9	2	Screw-HH 3/8-16 X 1 3/4
2:3	116-3312	1	Spacer-Bearing	25	1-323539	2	Spacer-Blade Drive
3	116-3342	3	ASM-Spindle And Seal ■	26	1-806009	4	Hairpin-Cotter #206
4	116-1286	3	Guard,Bearing Top .989	27	1-806332	2	Rollpin 1/4 X 1 1/2
5	116-0674	3	Sheave,Blade Drive 5.90	28	104-8301	4	Nut-Nyloc 3/8-16 Flg
6	103-6381	3	Blade, Solid	29	322-3	2	Screw-HH 5/16-18 X 3/4
6	103-6386	3	Blade, Low Lift	30	322-2	1	Screw-HH 5/16-18 X 5/8
6	103-6391	3	Blade, Mulching ●	31	104-8300	3	Nut-Nyloc 5/16-18 Flg
6	116-5177	3	Blade-Extreme 2, 16.25"	32	116-9981	4	Kit, Anti-Scalp Roller
6	103-6401	3	Blade-Notched	33	109-6936	1	Cover-Belt, LH
7	103-3037	3	Bushing, Splined	34	109-6935	1	Cover-Belt, RH
9	109-9220	3	Screw-Sems 1/2-20 X 2.19	35	126-0959	1	ASM, Discharge Chute
10	103-2802	3	Washer-Spring Disc 3/4	35:1	109-2738	1	Chute, Discharge
11	116-7306	3	Nut-Hex	35:2	126-0958-01	1	Bracket, Discharge Chute
12	109-2872	2	Spacer-Pulley	35:3	3231-22	3	Bolt-Carriage 3/8-16 X 1
13	116-4669	2	Pulley-Idler Flat	35:4	109-6658	3	Nut-Nyloc 3/8-16 Flg
14	126-2314	1	ASM, Deck Idler	36	3231-22	2	Bolt-Carriage 3/8-16 X 1
15	116-4668	1	Idler-Pulley, Flanged	37	116-6317	1	Spring-Extension
16	1-603001	2	Rod, Deck Support	38	126-0783	1	Belt, Deck
17	1-413425	2	Spacer-Deck Support	39	3231-40	2	Bolt-Carriage 3/8-16 X 2 1/4
18	103-2916	1	Guard-Top	40	3231-24	1	Bolt-Carriage 3/8-16 X 3 3/4
19	126-2782-01	1	Baffle, Dogleg	41	116-9362	4	Screw-HH 3/8-16 X 3 3/4 Gr 8
20	109-6658	25	Nut-Nyloc 3/8-16 Flg	42	98-5975	4	Washer-Spring Disc 3/8
21	126-1680	1	Screw-Hfh	43	116-8131	4	Axle, Roller
22	1-603050	2	Spacer	44	103-8415	4	Roller-Anti-Scalp
23	1-414521	2	Link Assy	45	1-411532	2	Kit, Support Link W/Pin
23:1	1-413525	1	Link, Rear Deck Support				

● Requires installation of mulch kit for proper mulching. See your Exmark dealer for details.

■ Apply Mobil HTS grease (P/N 103-5217 1.5 oz packet) (or a food-grade anti-seize). See operator s manual for locations.

Deck W/Decals Assembly No. 126-0781

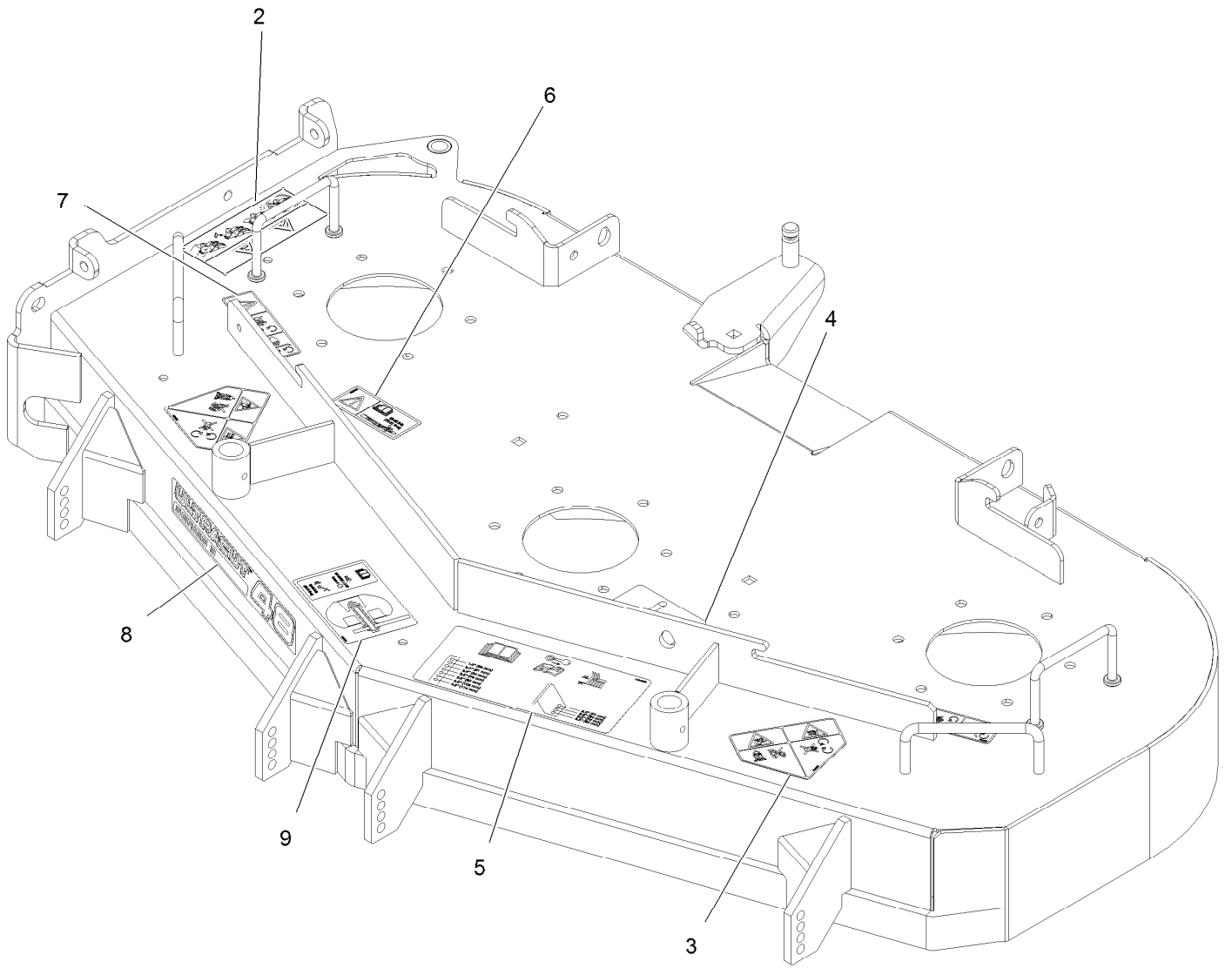

Deck W/Decals Assembly No. 126-0781 (continued)

<i>Ref.</i>	<i>Part Number</i>	<i>Qty.</i>	<i>Description</i>	<i>Ref.</i>	<i>Part Number</i>	<i>Qty.</i>	<i>Description</i>
2	114-3489	1	Decal-Warning, Bagger	6	116-8283	1	Decal-Bolt Torque
3	112-8760	2	Decal-Danger	7	112-9028	3	Decal-Missing, Cover
4	116-8727	1	Decal-Belt Routing	8	126-6746	1	Decal-Ultracut 48 Series 3
5	116-8278	1	Decal-Anti-Scalp	9	126-0898	1	Decal-Roller Mounting

Deck Idler Assembly No. 126-2314

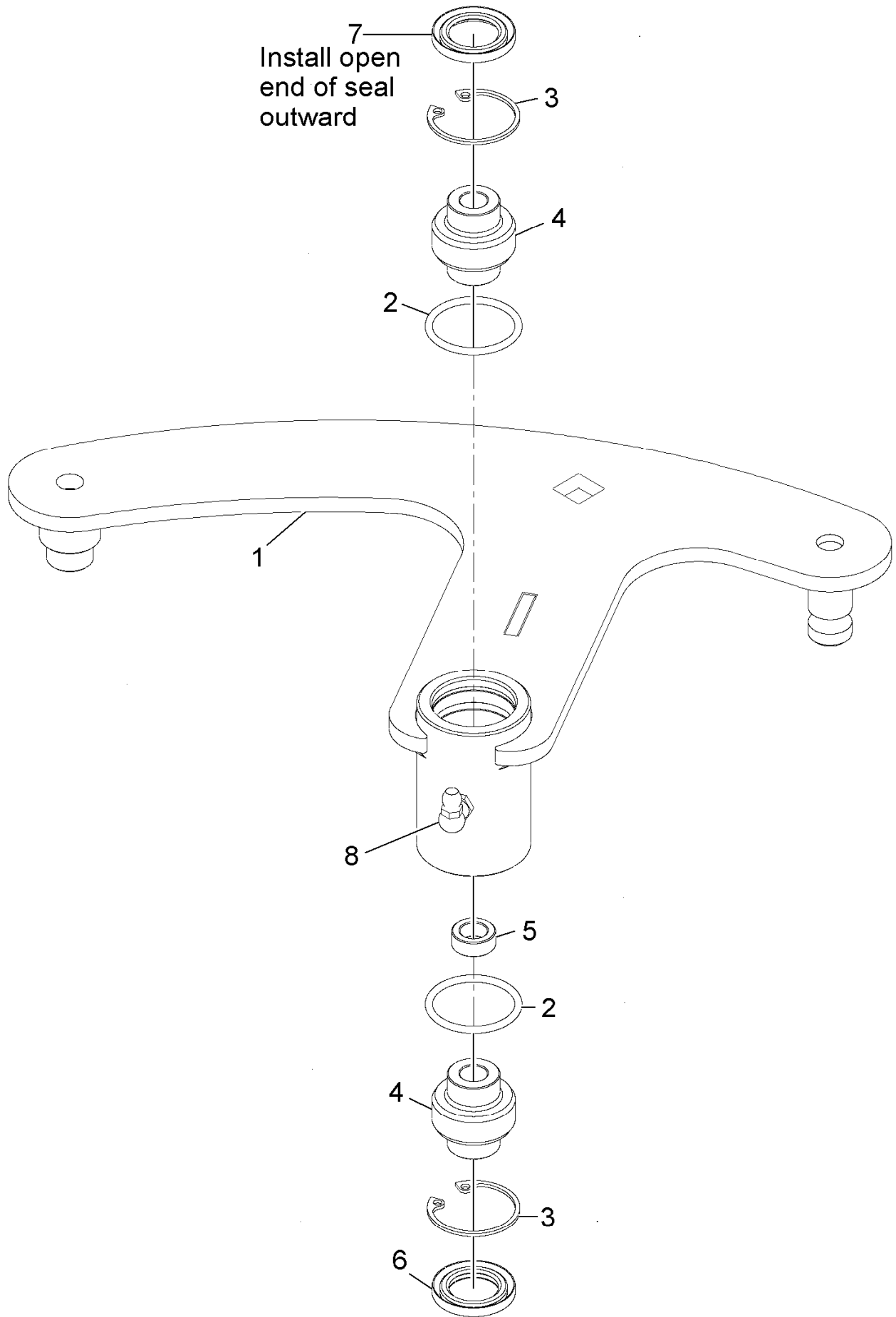

Deck Idler Assembly No. 126-2314 (continued)

<i>Ref.</i>	<i>Part Number</i>	<i>Qty.</i>	<i>Description</i>	<i>Ref.</i>	<i>Part Number</i>	<i>Qty.</i>	<i>Description</i>
1		1	Weld, Idler Arm ●	5	103-5677	1	Spacer
2	106-7159	2	O-Ring	6	103-3505	1	Seal-Double Lip
3	32120-10	2	Ring-Snap	7	103-3506	1	Seal-Lip, Single
4	103-3504	2	Bearing-Spherical	8	302-40	1	Fitting-Grease, 90 DEG

● Not serviced separately

Main Frame Assembly

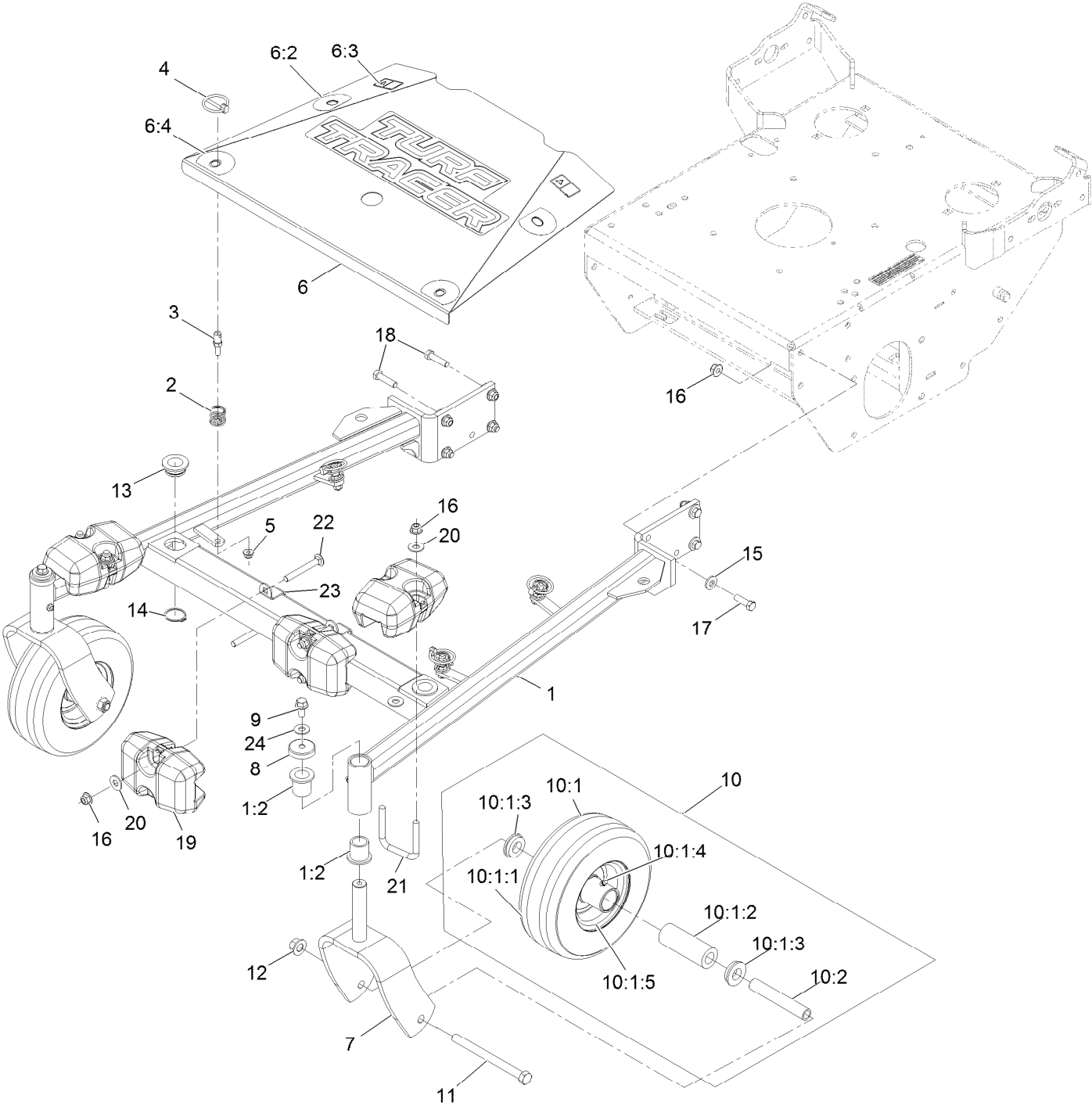

Main Frame Assembly (continued)

<i>Ref.</i>	<i>Part Number</i>	<i>Qty.</i>	<i>Description</i>	<i>Ref.</i>	<i>Part Number</i>	<i>Qty.</i>	<i>Description</i>
1	126-1514	1	ASM, Frame W/ Bushings, 48	10:1:2	1-513809	1	Bearing
1:2	1-303514	4	Bearing-Flanged	10:1:3	1-513810	2	Bushing-Flanged
2	126-1503	4	Spring	10:1:4	302-61	1	Zerk-45° 1/4-28
3	126-1504	4	Pin, Spring	10:1:5		1	Wheel ●
4	92-1298	4	Pin-Lynch	10:2	1-513547	1	Spacer
5	104-8300	4	Nut-Nyloc 5/16-18 Flg	11	325-20	2	Screw-HH 1/2-13 X 6
6	126-1517	1	ASM, Shield W/ Decals, 48	12	99-5107	2	Nut-Lock 1/2-13
6:2	126-6892	1	Decal-Turf Tracer	13	1-513336	2	Bushing-Deck
6:3	106-5517	2	Decal-Warning, Hot Surface	14	32120-33	2	Ring-Retaining
6:4	126-1692	4	Decal-Scratch Cover	15	98-5975	8	Washer-Spring Disc 3/8
7	116-7941-01	2	Fork, Caster [red]	16	104-8301	16	Nut-Nyloc 3/8-16 Flg
8	126-1425	2	Cap, Dust	17	323-7	6	Screw-HH 3/8-16 X 1 1/4
9	110-1718	2	Screw-Hex Flange 3/8-16 X 3/4	18	323-8	2	Screw-HH 3/8-16 X 1 1/2
10	1-513547	2	Spacer	19	103-2455-01	4	Weight-Support, Caster
10	103-2171	2	Kit,Semi-Pneumatic Wheel Replacement	20	3256-4	8	Washer-Flat
10:1		1	Wheel And Tire ASM ●	21	103-2469	2	U-Bolt
10:1:1		1	Tire ●	22	3231-10	4	Screw-CARR
				23	126-3851-01	2	Strap, Weight
				24	1-373034	2	Washer

● Not serviced separately

Engine Deck

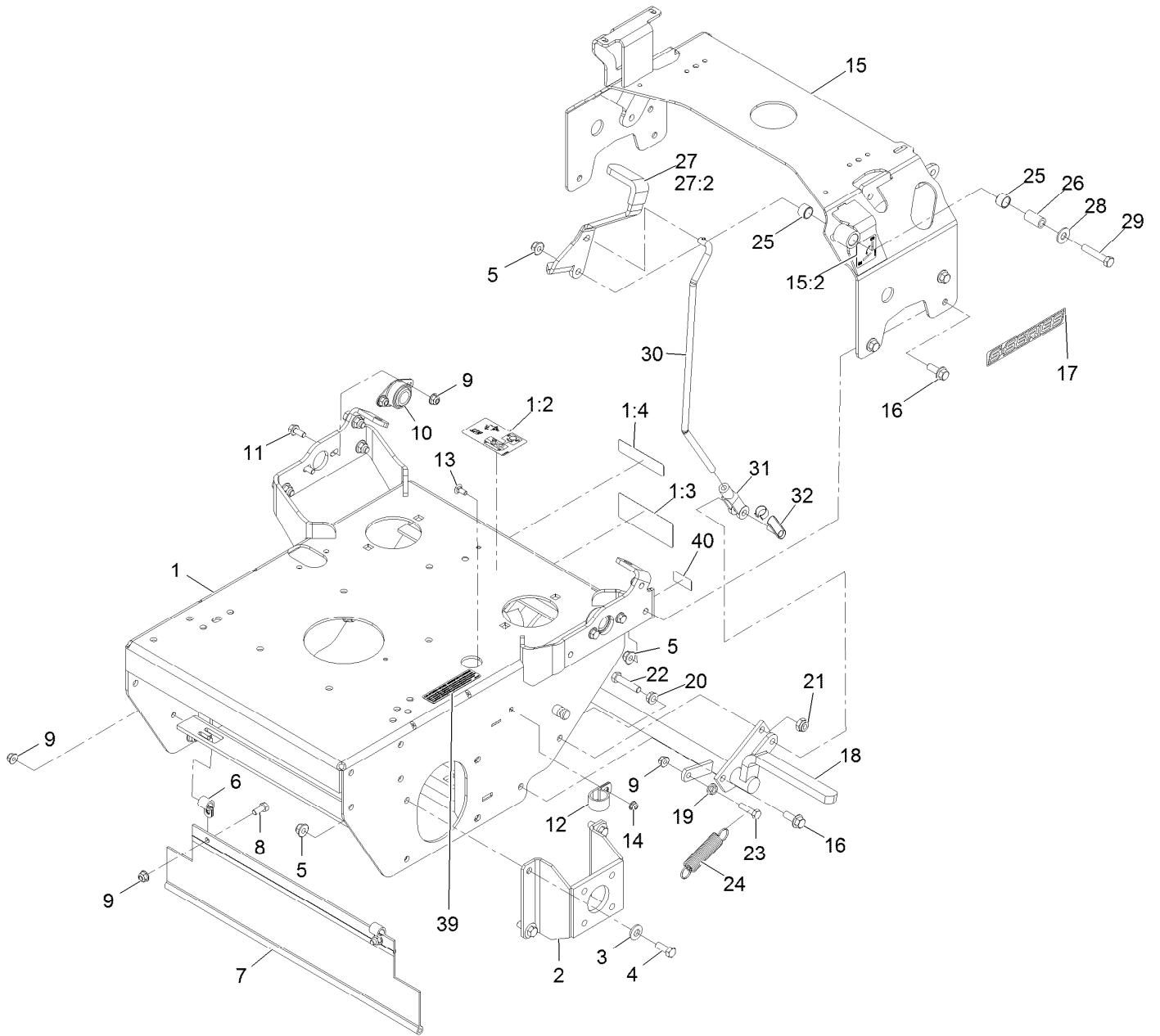

Engine Deck (continued)

<i>Ref.</i>	<i>Part Number</i>	<i>Qty.</i>	<i>Description</i>	<i>Ref.</i>	<i>Part Number</i>	<i>Qty.</i>	<i>Description</i>
1	126-1238	1	ASM, Engine Deck W/ Decals	16	3234-42	9	Screw HHF 3/8-16 X 1
1:2	116-8253	1	Decal-Drive Release	17	126-6572	2	Decal-S-Series
1:3	126-1400	1	Decal-Warning, Sulky	18	116-9964	1	Brake
1:4	98-1977	1	Decal-Warning	19	32128-20	1	Nut-Whizlock 5/16-18
2	1-412082-01	2	Mount-Wheel Motor	20	3290-357	1	Nut-Whizlock 3/8-16
3	98-5975	8	Washer-Spring Disc 3/8	21	3296-44	1	Nut-Lock, NI
4	323-6	8	Screw-HH 3/8-16 X 1	22	323-9	1	Screw-HH 3/8-16 X 1 3/4
5	104-8301	18	Nut-Nyloc 3/8-16 Flg	23	322-6	1	Screw-HH 5/16-18 X 1 1/4
6	1-413510	2	Clip-Loom	24	1-323161	1	Spring
7	103-2056	1	Shield-Drag	25	1-413347	2	Sleeve-Bushing
8	322-3	2	Screw-HH 5/16-18 X 3/4	26	1-413344	1	Bushing-Pivot
9	104-8300	7	Nut-Nyloc 5/16-18 Flg	27	126-2180	1	ASM, Brake Lever W/ Grip
10	1-633102	2	Bearing-Flanged	27:2	1-303020	1	Grip-Lever
11	3234-47	4	Screw-HH Flg 5/16-18 X 3/4	28	3256-4	1	Washer-3/8 Std
12	1-643312	1	Clip-Loom	29	323-10	1	Screw-HH 3/8-16 X 2
13	3229-11	1	Bolt-Carriage 1/4-20 X 5/8	30	116-9959	1	Linkage, Brake
14	104-7201	1	Nut-Nyloc 1/4-20 Flg	31	1-633131	1	Yoke-Linkage, Brake
15	126-2181	1	ASM, Tank Support W/ Decal	32	103-2399	1	Pin-Clevis Spring 3/8
15:2	116-5988	1	Decal-Park Brake, Ce	39	117-2718	1	Decal-Arrester, Spark
				40	126-4345	1	Decal-Patent Ttco.Com

Handle Assembly

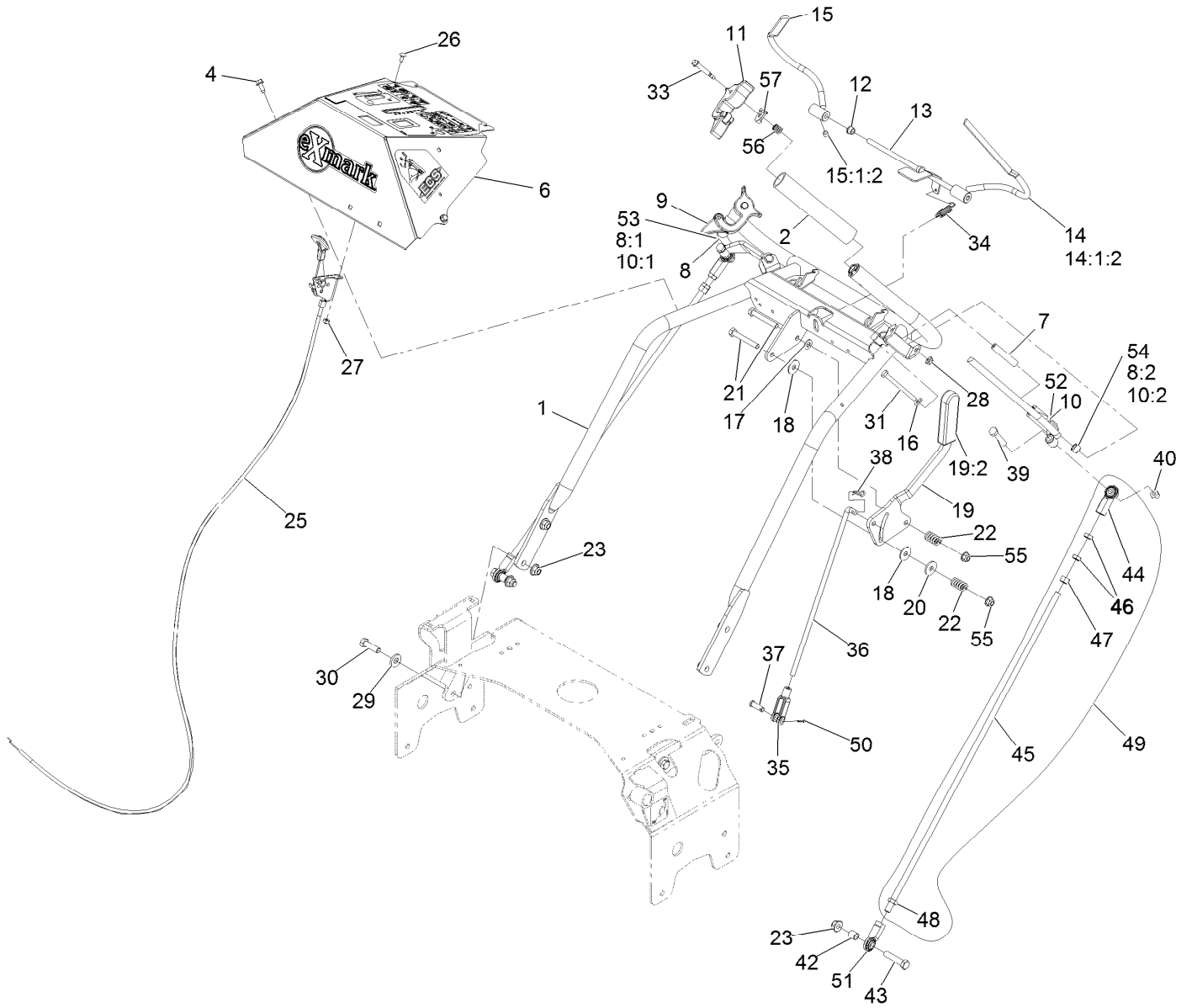

Handle Assembly (continued)

<i>Ref.</i>	<i>Part Number</i>	<i>Qty.</i>	<i>Description</i>	<i>Ref.</i>	<i>Part Number</i>	<i>Qty.</i>	<i>Description</i>
1	126-2642-03	1	Weld, Handle	27	3296-2	2	Nut-Nyloc #10-24
2	103-0815	2	Grip-Bar, Handle	28	104-7201	2	Nut-Nyloc 1/4-20 Flg
4	32144-10	2	Screw-HWH 1/4-20 X .62	29	98-5975	4	Washer-Spring Disc 3/8
6	126-4705	1	ASM, Console W/ Decals	30	323-7	4	Screw-HH 3/8-16 X 1 1/4
7	103-0027	2	Bushing-Lever, Drive	31	321-14	2	Screw-HH 1/4-20 X 2 3/4
8	103-2513	1	Asm, Drive Lever RH	33	126-2931	2	Screw-Shoulder
8:1	116-4082	1	Wld,RH Drive Lever	34	1-303363	1	Spring-Extension
8:2	1-413152	2	Bushing-Sleeve	35	1-303105	1	Yoke-Adjustable
9	103-1371	1	Thumb Latch Asm RH	36	1-413225	1	Rod, Speed Control
10	103-2514	1	Asm, Drive Lever LH	37	1-808280	1	Pin-Clevis 5/16 X 1 49/64
10:1	116-4081	1	Wld,LH Drive Lever	38	1-806003	1	Hairpin-Cotter
10:2	1-413152	2	Bushing-Sleeve	39	322-9	2	Screw-HH 5/16-18 X 1 3/4
11	103-1372	1	Thumb Latch Asm LH	40	3296-29	2	Nut-Nyloc 5/16-18
12	1-303365	2	Bushing-Nylon	42	103-1166	2	Spacer-Tube, Pump Link
13	103-0769-03	1	Rod Weldment, Opc	43	323-9	2	Screw-HH 3/8-16 X 1 3/4
14	116-4079	1	Wld,LH Opc Lever ■	44	103-2463	2	Balljoint
14:1:2	1-803322	1	Setscrew-5/16-24 X 5/16 ●	45	103-1148	2	Rod,Drive Lever
15	116-4080	1	Wld,RH Opc Lever ■	46	3220-3	4	Nut-Jam 3/8-24
15:1:2	1-803322	1	Setscrew-5/16-24 X 5/16 ●	47	3219-3	2	Nut-Hex 3/8-24
16	3256-22	2	Washer-1/4 Sae	48	3220-16	2	Nut-Jam 3/8-24 LH
17	3256-23	1	Washer-5/16 Sae	49	116-3414	2	Drive Link ASM
18	1-323244	2	Washer-Friction	50	3272-5	1	Pin-Cotter 3/32 X 1/2
19	126-0148	1	Lever, Shift W/Grip	51	103-1167	2	Joint-Ball End
19:2	103-5994	1	Grip-Handle, Steering	52	116-4081	1	Wld,LH Drive Lever
20	1-603716	1	Washer-Friction Disc	53	116-4082	1	Wld,RH Drive Lever
21	322-11	2	Screw-HH 5/16-18 X 2 1/4	54	1-413152	4	Bushing-Sleeve
22	1-323245	2	Spring-Compression	55	104-8300	2	Nut-Nyloc 5/16-18 Flg
23	104-8301	6	Nut-Nyloc 3/8-16 Flg	56	1-633349	2	Spring-Compression
25	109-3958	1	Control-Throttle	57	126-2921	2	Latch, Ecs
26	1-807513	2	Bolt-Carriage #10-24 X 1/2				

● Use Pro-Lock, Nut Type (P/N 1-840022, .5ml tube) on threads.

■ Use Pro-Lock retaining type, Part no. 1-840023 (.5cc tube) on inside of bore of OPC hub.

Controls Assembly



Controls Assembly (continued)

<i>Ref.</i>	<i>Part Number</i>	<i>Qty.</i>	<i>Description</i>	<i>Ref.</i>	<i>Part Number</i>	<i>Qty.</i>	<i>Description</i>
1	116-9975	1	Weld, Motion Control, Rt	15	1-808280	2	Pin-Clevis 5/16 X 1 49/64
2	116-9974	1	Weld, Motion Control, Lt	16	1-806003	2	Hairpin-Cotter
3	1-803022	2	Setscrew-5/16-18 X 5/8	17	1-613089	2	Tab-Spring, Extension
4	126-2982-01	1	Weld, Speed Control	18	1-603693	2	Spring
5	1-603735	2	Bushing-Flanged	19	126-0610	2	Pin, Motion Control
6	103-0265	2	Spring, Neutral Return	20	1-603676	2	Swivel-Adjustable, Short
7	1-603737	2	Bolt-Neutral Return	21	1-413350	2	Link-Control, Speed
8	3256-23	9	Washer-5/16 Sae	22	3272-5	2	Pin-Cotter 3/32 X 1/2
9	3219-2	7	Nut-Hex 5/16-24	23	1-323245	1	Spring-Compression
10	3220-2	2	Nut-Jam 5/16-24	24	1-603903	1	Spacer
11	104-8300	6	Nut-Nyloc 5/16-18 Flg	25	103-3060	1	Knob-Tracking
12	32128-20	2	Nut-Whizlock 5/16-18	27	1-809056	2	Screw-Sh 5/16-18 X 1 3/8
13	322-5	2	Screw-HH 5/16-18 X 1	28	116-7918	1	Decal-Tracking Adjustment
14	1-303105	2	Yoke-Adjustable	29	302-19	2	Zerk-1/4-28 Str

Fuel Assembly

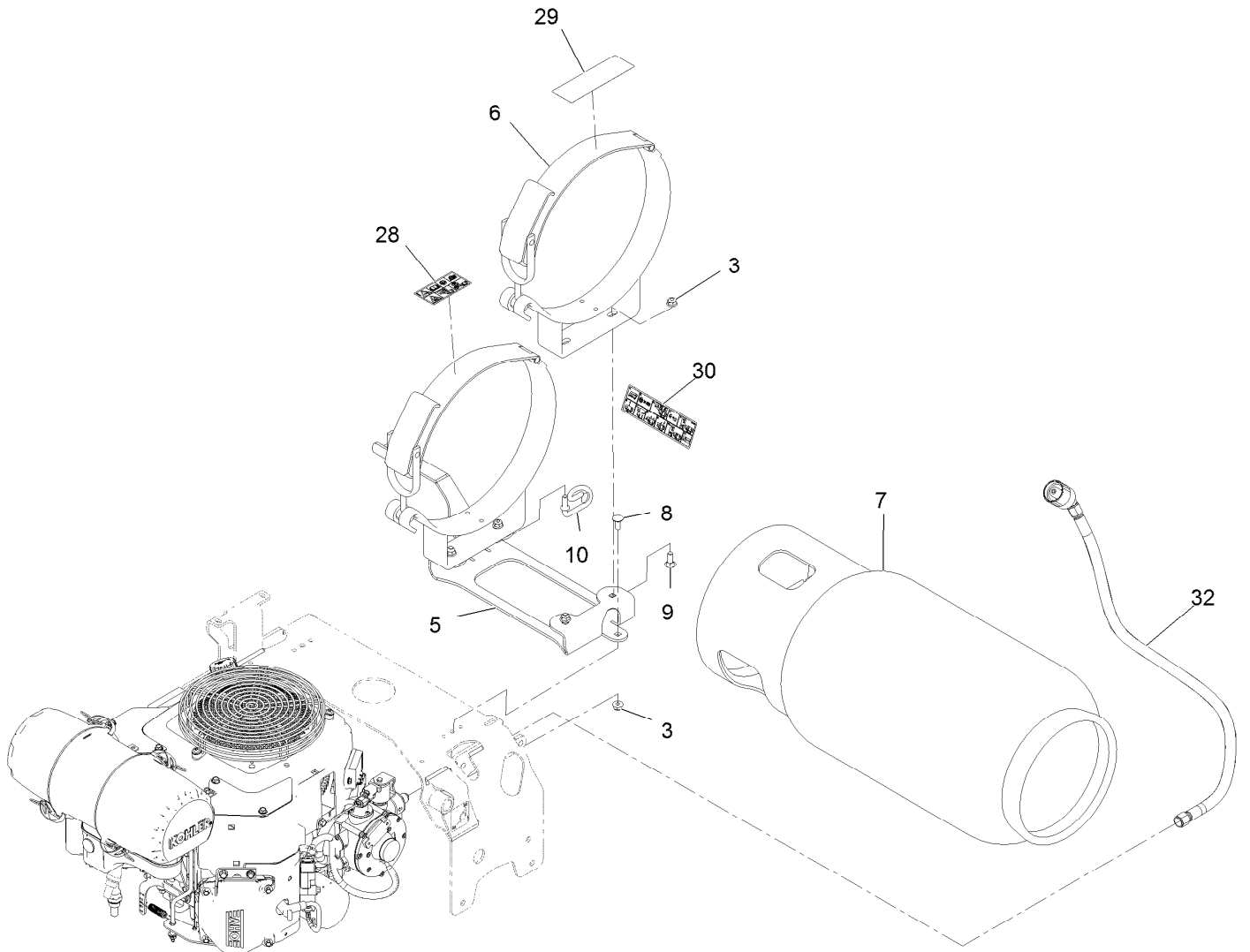

Fuel Assembly (continued)

<i>Ref.</i>	<i>Part Number</i>	<i>Qty.</i>	<i>Description</i>	<i>Ref.</i>	<i>Part Number</i>	<i>Qty.</i>	<i>Description</i>
3	104-8300	6	Nut-Nyloc 5/16-18 Flg	9	3230-16	3	Bolt-Carriage 5/16-18 X 7/8
5	126-1491-03	1	Weld, Tank Mount	10	126-1921	1	Retainer, LP Hose
6	116-1074	1	Brackets, LPG Tank - Horizontal (Pair)	28	126-3275	1	Decal-LPG Warning
7	126-4506	1	Tank, LP - 33.5 Lb.Horizontal-Al	29	126-3276	1	Decal-LPG Horiz Tank Spec
8	3230-23	2	Bolt-Carriage 5/16-18 X 3/4 Short Neck	30	126-3277	1	Decal-LPG Fuel Tank Replacement
				32	126-2144	1	ASM, Hose-LPG

Engine Assembly

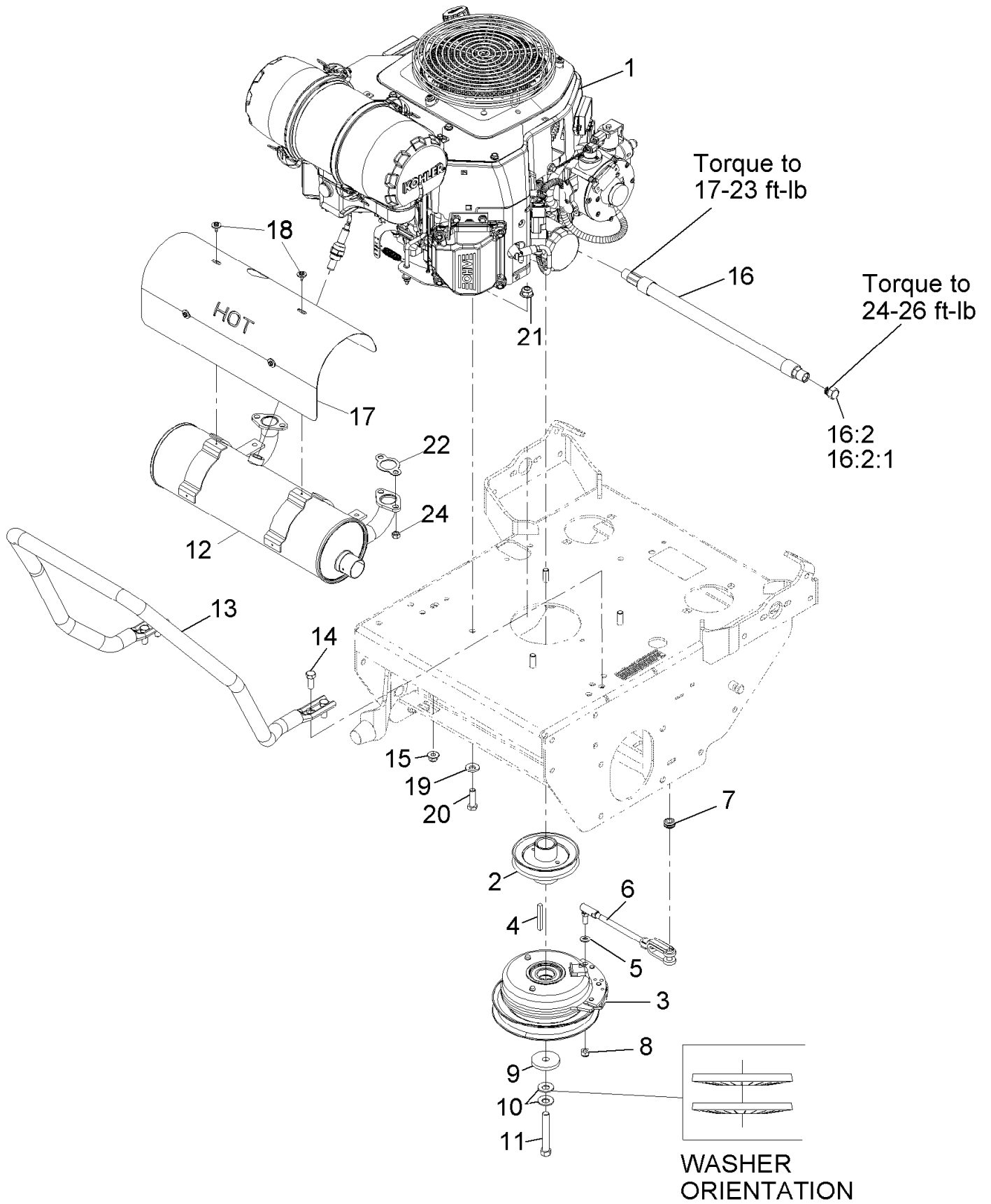

Engine Assembly (continued)

<i>Ref.</i>	<i>Part Number</i>	<i>Qty.</i>	<i>Description</i>	<i>Ref.</i>	<i>Part Number</i>	<i>Qty.</i>	<i>Description</i>
1		1	Engine, Kohler Pcv680 ●■	14	323-6	4	Screw-HH 3/8-16 X 1
2	116-7328	1	Sheave, W/ Hub	15	104-8301	4	Nut-Nyloc 3/8-16 Flg
3	126-2616	1	Clutch, 125 Ft/Lbs, 1.13	16	116-5316	1	Oil Drain Hose ASM ▲
4	5-1336	1	Key-Machine 1/4 X 1/4 X 2 □	16:2	353-508	1	Plug-W/O-Ring
5	3256-23	1	Washer-5/16 Sae	16:2:1	237-42	1	O-Ring
6	126-0620	1	ASM, Clutch Anchor	17	116-8654	1	Shield-Muffler
7	237-136	1	Grommet	18	116-1103	4	Screw-HH, Thread Forming
8	3296-4	1	Nut-Lock 5/16-24	19	1-303334	4	Washer-Spring Disc 5/16
9	109-6919	1	Washer-Clutch	20	322-7	4	Screw-HH 5/16-18 X 1 1/2
10	1-603610	2	Washer-Spring Disc 7/16	21	104-8300	4	Nut-Nyloc 5/16-18 Flg
11	3212-12	1	Screw-HH 7/16-20 X 3 ◆	22	110-6697	2	Gasket-Exhaust
12	116-8653	1	Muffler	24	114-3549	4	Nut-M8
13	116-8575-03	1	Guard,Air Cleaner				

● Not serviced separately

■ Obtain parts from www.kohlerplus.com

▲ Use a Teflon Pipe Sealant or equivalent on threads.

◆ Use Pro-Lock, Nut Type (P/N 1-840022, .5ml tube) on threads.

□ Apply anti-seize compound to engine crankshaft, pulley hub I.D., clutch bore I.D. and square key.

Ground Drive Assembly

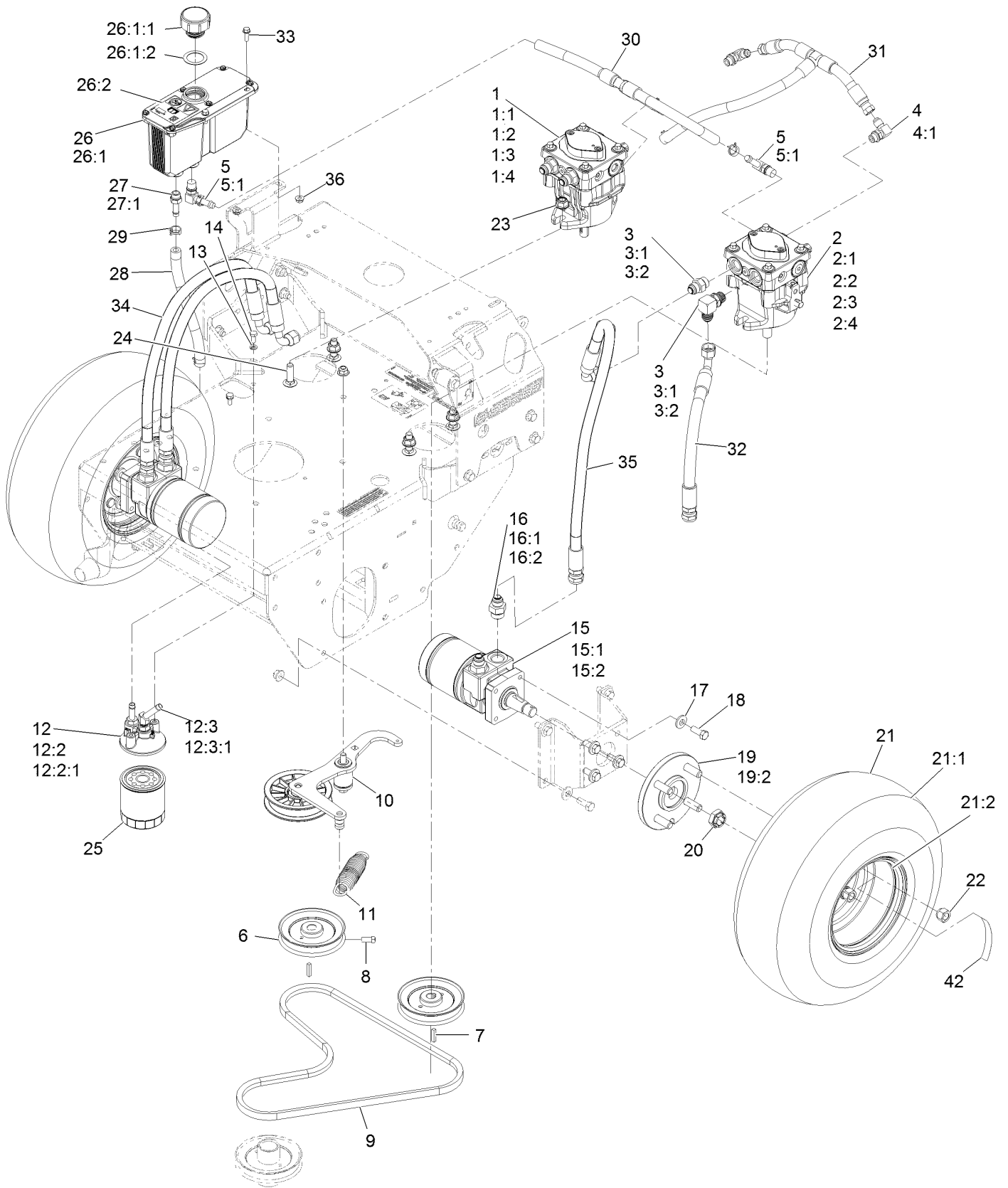

Ground Drive Assembly (continued)

<i>Ref.</i>	<i>Part Number</i>	<i>Qty.</i>	<i>Description</i>	<i>Ref.</i>	<i>Part Number</i>	<i>Qty.</i>	<i>Description</i>
1	116-0943	1	RH HYD Pump ASM	15:2	1-000138	1	Bearing And Seal Kit
1:1	103-2664	1	Input Shaft Kit	16	1-603991	4	Adapter-Straight
1:2	94-6922	1	Bearing-Thrust	16:1	237-80	1	O-Ring
1:3	103-2666	1	Cylinder Block Kit	16:2	1-603992	1	O-Ring-37 Flare #8
1:4	105-6184	1	Seal Overhaul Kit	17	98-5975	8	Washer-Spring Disc 3/8
2	116-0942	1	LH HYD Pump ASM	18	323-6	8	Screw-HH 3/8-16 X 1
2:1	103-2664	1	Input Shaft Kit	19	112-9049	2	Wheel Hub ASM
2:2	94-6922	1	Bearing-Thrust	19:2	1-633926	4	Stud-Wheel
2:3	103-2666	1	Cylinder Block Kit	20	116-2839	2	Nut-Lock
2:4	105-6184	1	Seal Overhaul Kit	21	1-613263	2	Wheel And Tire ASM
3	1-603990	3	Adapter-Straight	21:1	1-613264	1	Tire-Turfmaster
3	103-2153	1	Elbow-90°	21:2	1-603715	1	Wheel-Rim
3:1	1-603920	1	O-Ring-Sae #8	22	242-50	8	Nut-Lug 1/2-20
3:1	1-603920	1	O-Ring-Sae #8	23	114-8417	4	Nut-HF, NI
3:2	1-603992	1	O-Ring-37 Flare #8	24	3232-3	4	Bolt-Carriage 7/16-14 X 1 1/2
3:2	1-603992	1	O-Ring-37 Flare #8	25	109-4180	1	Element, Oil Filter
4	103-1802	2	Fitting-HYD, 90 DEG	26	126-1248	1	ASM, HYD Reservoir ■
4:1	1-603921	1	O-Ring-Sae #6	26:1		1	Reservoir-HYD ●
5	100-4887	3	Fitting-Barbed, 90 DEG	26:1:1	103-1948	1	Cap-Reservoir, HYD
5:1	237-42	1	O-Ring	26:1:2	103-1949	1	Gasket-Cap
6	1-413010	2	Sheave ASM	26:2	115-4212	1	Decal-Warning
7	1-807272	2	Key-5Mm X 5Mm X 25Mm	27	103-1912	1	Adapter-Straight
8	120-6474	4	Screw-Set, SQH 5/16-18 X 3/4	27:1	237-42	1	O-Ring
9	103-4761	1	Belt	28	103-2959	1	Hose-Charge
10	126-0615	1	ASM, Pump Idler	29	103-1988	6	Clamp-Hose 11/16
11	116-6316	1	Spring-Extension	30	126-0623	1	Hose-Case Drain
12	126-0621	1	ASM, Filter Head	31	126-0622	1	Hose-Charge
12:2	103-1912	1	Adapter-Straight	32	126-0856	1	ASM, HP Hose
12:2:1	237-42	1	O-Ring	33	32105-15	2	Screw-Machine 1/4-20 X 3/4
12:3	103-1807	1	Fitting-Barbed, 45 DEG	34	119-7827	2	HYD Hose ASM
12:3:1	237-42	1	O-Ring	35	119-7826	1	HYD Hose ASM
13	1-805004	2	Washer-Lock 1/4 Heavy	36	32128-33	2	Nut-Whizlock 1/4-20
14	321-3	2	Screw-HH 1/4-20 X 5/8	42	126-2056	2	Decal-Torque Wheel Lug-Hub
15	1-603718	2	HYD Motor ASM				
15:1	1-000119	1	Seal Kit				

● Not serviced separately

■ Use Exmark Premium Hydro Oil P/N 109-9828 (32oz)

Pump Idler Assembly No. 126-0615

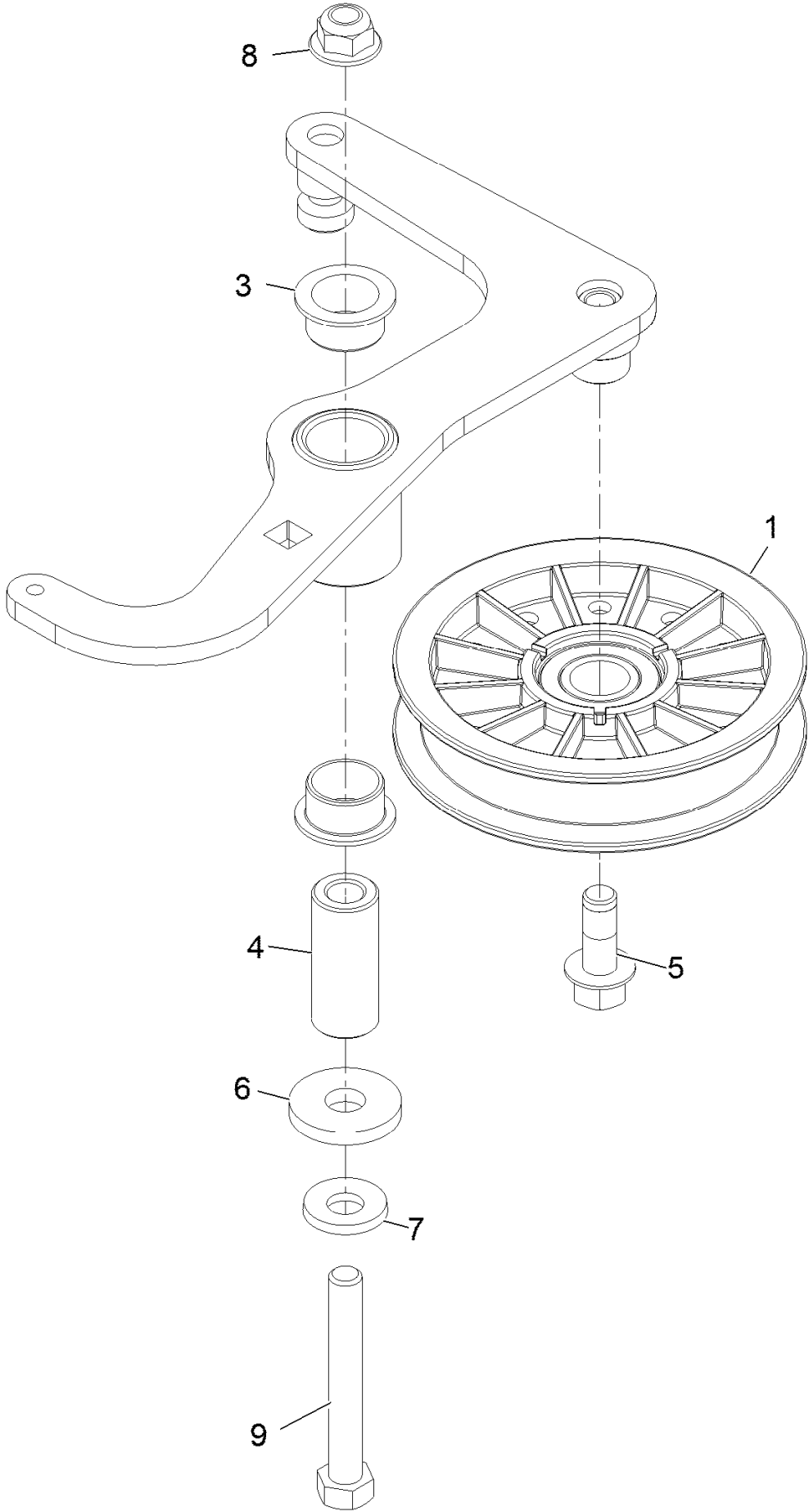

Pump Idler Assembly No. 126-0615 (continued)

<i>Ref.</i>	<i>Part Number</i>	<i>Qty.</i>	<i>Description</i>	<i>Ref.</i>	<i>Part Number</i>	<i>Qty.</i>	<i>Description</i>
1	109-4077	1	Pulley-Idler, Flat	6	1-373034	1	Washer
3	109-8054	2	Bushing-Flanged	7	98-5975	1	Washer-Spring Disc 3/8
4	116-8718	1	Spacer, Pivot	8	104-8301	1	Nut-Nyloc 3/8-16 Flg
5	126-1680	1	Screw-Hfh	9	112-7451	1	Screw-TAP

Electrical Assembly

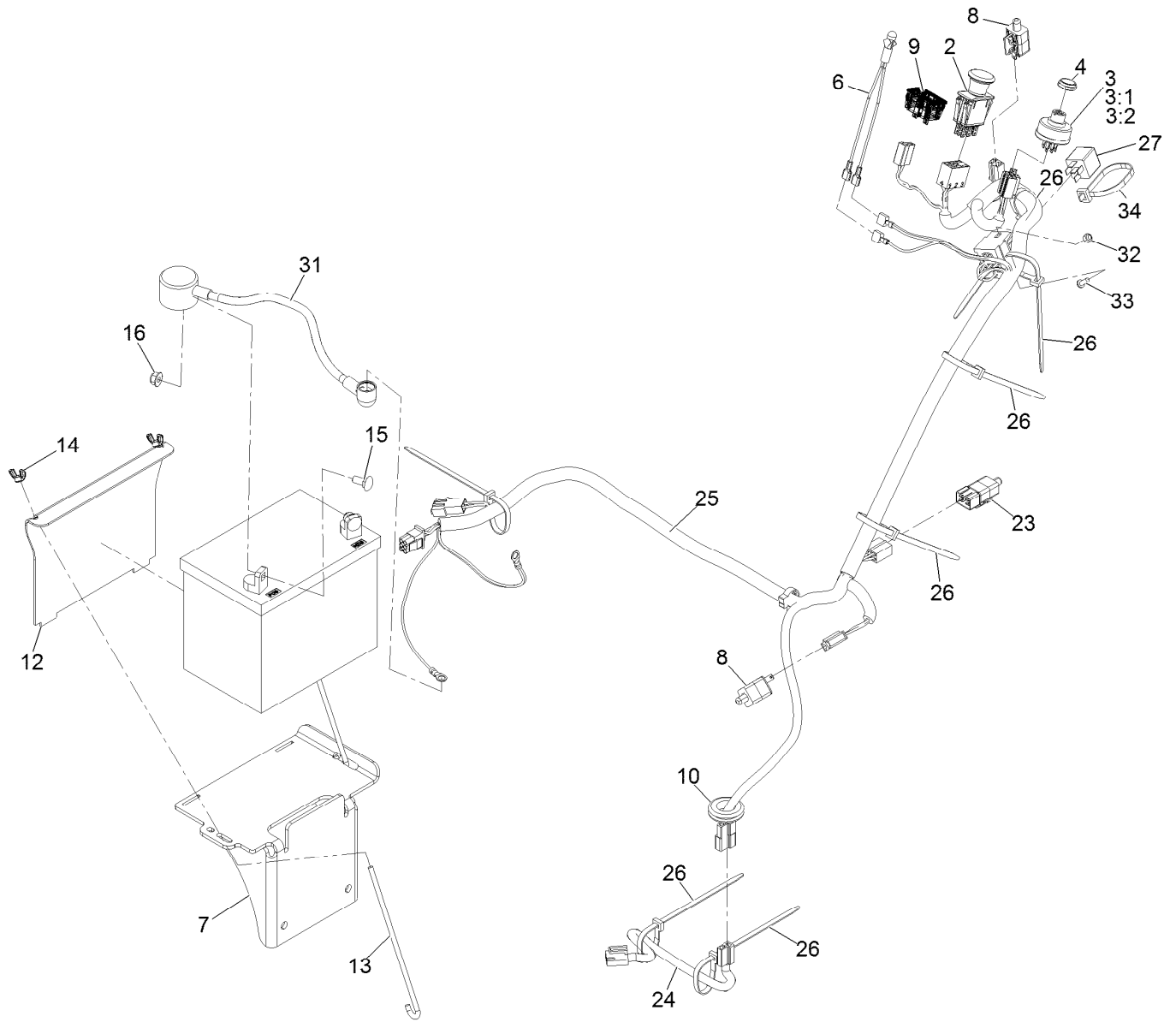

Electrical Assembly (continued)

<i>Ref.</i>	<i>Part Number</i>	<i>Qty.</i>	<i>Description</i>	<i>Ref.</i>	<i>Part Number</i>	<i>Qty.</i>	<i>Description</i>
2	103-5221	1	Switch-PTO	15	3230-1	2	Bolt-Carriage 5/16-18 X 3/4
3	103-0206	1	Switch-Ignition W/Keys	16	104-8300	2	Nut-Nyloc 5/16-18 Flg
3:1	3254-5	1	Washer-Tooth, Internal	23	126-1904	1	Switch, 2 Pole
3:2	218-461	1	Nut-HH	24	126-0624	1	Harness-Clutch Pigtail
4	103-0498	1	Nut-Ignition	25	126-2985	1	Harness-Main ■
6	1-643267	1	Indicator-Red Led	26	1-303335	7	Tie-Cable 7 15/16 (Large)
7	126-1470-03	1	Weld, Battery Mount	27	1-643275	1	Relay-12Vdc 40 Amp
8	110-6765	2	Switch	30	1-413540	1	Cable-Battery, Negative ●
9	126-3931	1	Hour Meter	31	109-7628	1	Cable, Battery +
10	1-543286	1	Grommet	32	3296-2	1	Nut-Nyloc #10-24
12	126-0069-03	1	Bracket, Battery Hold Down	33	1-803071	1	Screw-Machine #10-24 X 1/2
13	1-633651	2	Bolt-Holddown	34	1-643115	1	Tie-Cable 11.4
14	1-543792	2	Wingnut-Nyloc 1/4-20				

● Not illustrated

■ Use dielectric grease on all unsealed connectors and terminals only. Do not apply in sealed connectors.

Notes:

EXMARK® MAINTENANCE

MAXIMIZE THE PERFORMANCE OF YOUR EXMARK.

4-CYCLE PREMIUM ENGINE OIL

Part No. 116-3373

Both SAE 30 and SAE 10W-30 in one bottle.

Contains increased levels of zinc and phosphorus for better lubricity.

No Viscosity Index Improvers that tend to shear down in high heat.

Synthetic formulation.

Gas & Diesel compatible.

Anti-corrosion additives.

API 'SL' and JASO rated with wet clutch compatibility for other machines.

PREMIUM HYDRO OIL

Part No. 109-9828

Commercial quality for tough, high-heat conditions.

Designed specifically for zero-turn mower hydraulic systems.

Superior shear resistance under heavy loads.

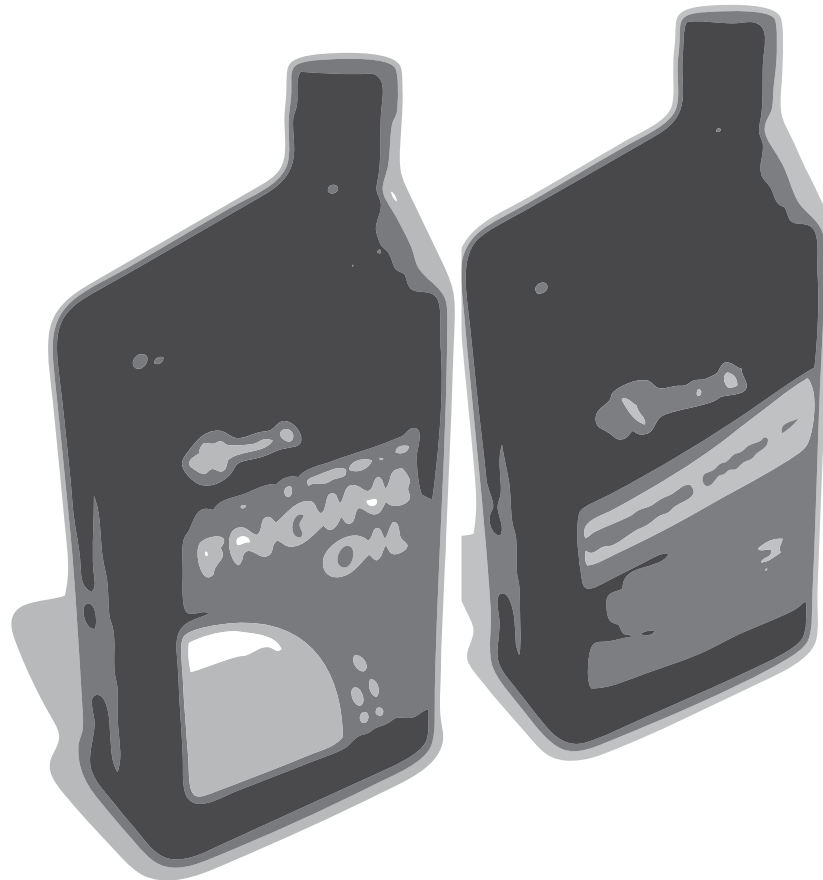

Available from your local Exmark dealer. Find your closest dealer at exmark.com

EXMARK ACCESSORIES AND OPTIONS*

MID-MOUNT RIDING ACCESSORIES AND OPTIONS

CUSTOM RIDE SEAT SUSPENSION SYSTEM	OPERATOR CONTROLLED DISCHARGE
FULL SUSPENSION SEAT	SUN SHADE
DECK LIFT ASSIST KIT	TRASH CONTAINER
HITCH KIT	TURF STRIPER
LIGHT KIT	ULTRA VAC COLLECTION SYSTEM
12V POWER PORT	ULTRA VAC QUICK DISPOSAL SYSTEM
MICRO-MULCH SYSTEM	

OUT-FRONT RIDING ACCESSORIES AND OPTIONS

CUSTOM RIDE SEAT SUSPENSION SYSTEM	SNOW BLADE
DUAL-TAIL WHEEL	SNOWBLOWER
FLOOR PAN EXTENDER	SUN SHADE
HITCH KIT	TRASH CONTAINER
LIGHT KIT	ULTRA VAC COLLECTION SYSTEM
MICRO-MULCH SYSTEM	ULTRA VAC QUICK DISPOSAL SYSTEM
ROLL OVER PROTECTION SYSTEM (ROPS)	WEATHER CAB

WALK-BEHIND ACCESSORIES AND OPTIONS

GRASS CATCHER	TURF STRIPER
MICRO-MULCH SYSTEM	STANDON

*Some accessories and options not available for some models.

Place Model No. and Serial No.
Label Here (Included in the Literature
Pack) or Fill in Below

Model No. _____

Serial No. _____

Date Purchased _____

Engine Model No. and Spec. No. _____

Engine Serial No. (E/No) _____

© 2015 Exmark Mfg. Co., Inc.
Industrial Park Box 808
Beatrice, NE 68310
All Rights Reserved

Part No. 4502-584 Rev. A
(402) 223-6300
Fax (402) 223-5489
Printed in the USA.

