

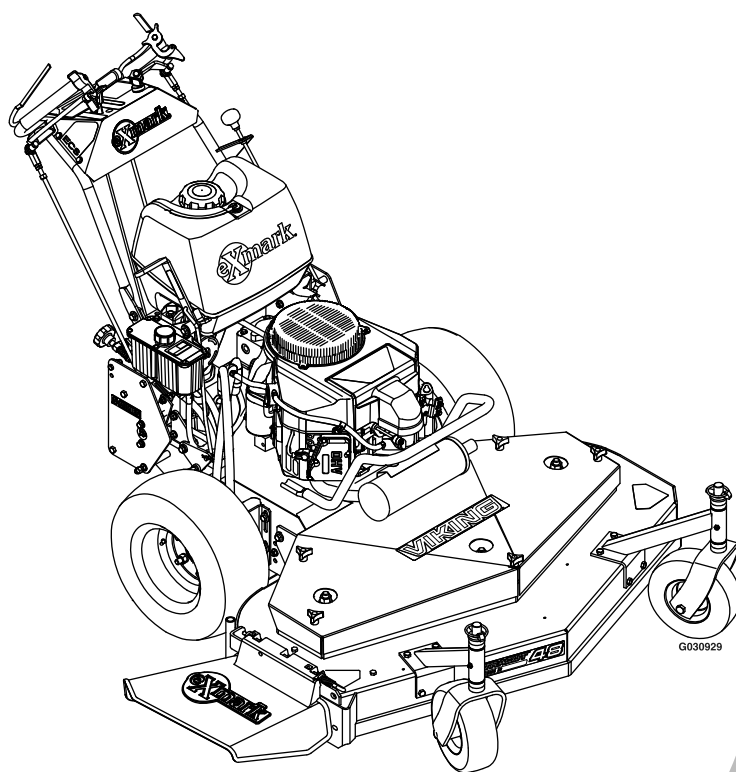

VIKING™ HYDRO

Model No. VHS481GKA36200—Serial No. 31600000 and Up

Picture below may not reflect actual product.



Parts Manual

Part No. 4502-568 Rev. A

Ordering Replacement Parts

To order replacement parts, please supply the part number, the quantity, and the description of each part desired.

Understanding Reference Numbers

Each identified part in an illustration has a reference number. The reference number for a part also appears in the parts list, along with other information about the part.

This catalog uses two special reference number formats, one to indicate parts in a service assembly and another to indicate the quantity of a given part in an illustration.

Service Assembly Reference Numbers

Parts in service assemblies have reference numbers in the form a:b. The a represents the reference number of the entire service assembly and the b represents a sequential number unique to each part within the service assembly.

For example, a wheel assembly might be identified by reference number 6, the tire by 6:1, the valve by 6:2, and the wheel by 6:3. When you order the assembly identified by reference number 6, you receive all parts identified by reference numbers 6:1, 6:2, and 6:3. However, you may also order any part individually. Reference numbers of this type appear in illustration and in parts lists.

Reference Numbers Indicating Quantity

In an illustration, if a reference number indicates more than one part, the reference number has the form nX y. The n represents the quantity of the part, the X is the multiplication symbol, and the y represents the reference number.

For example, in an illustration, the reference number 2X 37 means that two of the parts identified by reference number 37 are indicated.

List of Abbreviations

AR: as required	HLH: hex lag head	PTH: phillips truss head
ASM: assembly	HOC: height-of-cut	PTO: power-take-off
BBC: blade brake control	HP: high pressure	RH: right hand
BHTF: button head thread forming	HSBH: hex socket button head	ROPS: roll-over protection system
CARR: carriage	HSFH: hex socket flat head	RRB: rear roller brush
CCW: counter clockwise	HSH: hex socket head	SFH: slotted fillister head
CW: clockwise	HWH: hex washer head	SHH: slotted hex head
DEG: degrees	HWHTF: hex washer head thread forming	SHWH: slotted hex washer head
DPA: Dual Point Adjustment	HYD: hydraulic	SPH: slotted pan head
ECM: electronic control module	LH: left hand	SQH: square head
EXT: external	LP: low pressure	SRH: slotted round head
FH: flat head	LPG: Liquefied Petroleum Gas	STD: standard
GA: gauge	NI: nylon insert	TAP: self tapping
HD: heavy-duty	NPTF: national pipe thread fine	TTH: torx truss head
HF: hex flange	PFH: phillips flat head	
HH: hex head	PPH: phillips pan head	
HHF: hex head flange	PPHTF: phillips pan head thread forming	
HHFTF: hex head flange thread forming	PRH: phillips round head	
HJ: hex jam		

Touch Up Paint

Exmark black touch up spray paint – gloss black.

Exmark red touch up paint (spray paint – P/N 1-850337 - .6 oz liquid bottle – P/N 103-9140).



If your Exmark dealer does not have the Exmark part in stock, Exmark will get the parts to the dealer the next business day or the part will be FREE Guaranteed!! (Some restrictions apply. See your participating Exmark Dealer for details.)

Contents

Complete Deck Assembly.....	4
Deck Assembly.....	6
Deck W/Decals Assembly No. 103-2312.....	8
Caster Mount W/Weight Assembly No. 116-8245.....	10
Caster Wheel Support W/Bearings 103-2296.....	12
Caster Wheel Assembly No. 103-1236.....	14
Engine Deck Assembly.....	16
Engine Deck W/Decals Assembly No. 116-6132.....	18
Engine Deck Assembly and Park Brake Assembly.....	20
Engine Deck and Speed Control Assembly.....	22
Controls Assembly.....	24
Control Panel W/Decals Assembly No. 109-4931.....	26
Fuel Tank Assembly.....	28
Hydraulic Assembly.....	30
Electrical Assembly.....	32

Complete Deck Assembly

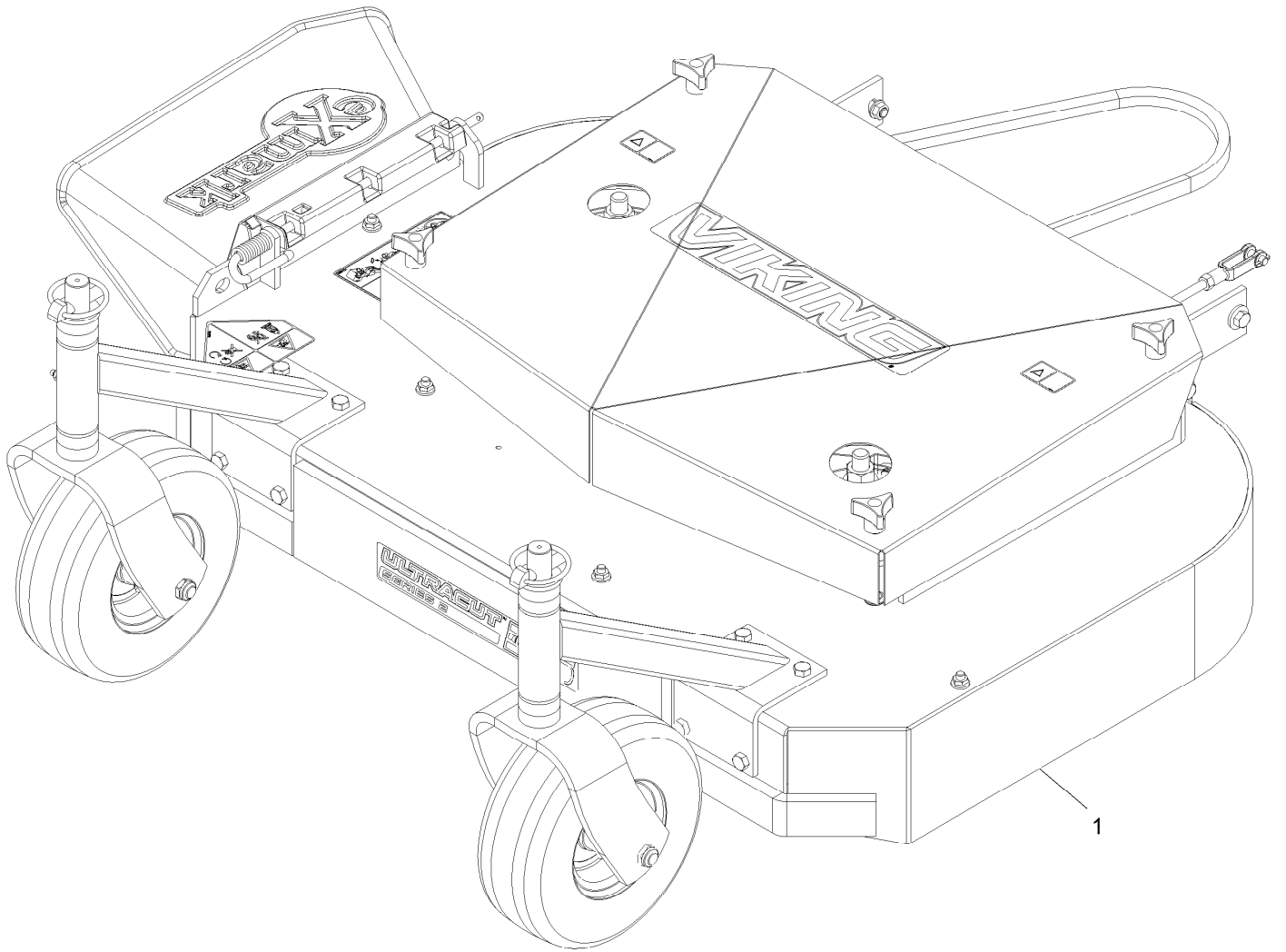

Complete Deck Assembly (continued)

<i>Ref.</i>	<i>Part Number</i>	<i>Qty.</i>	<i>Description</i>
1		1	Deck ASM-36 ●

● Not serviced separately

Deck Assembly

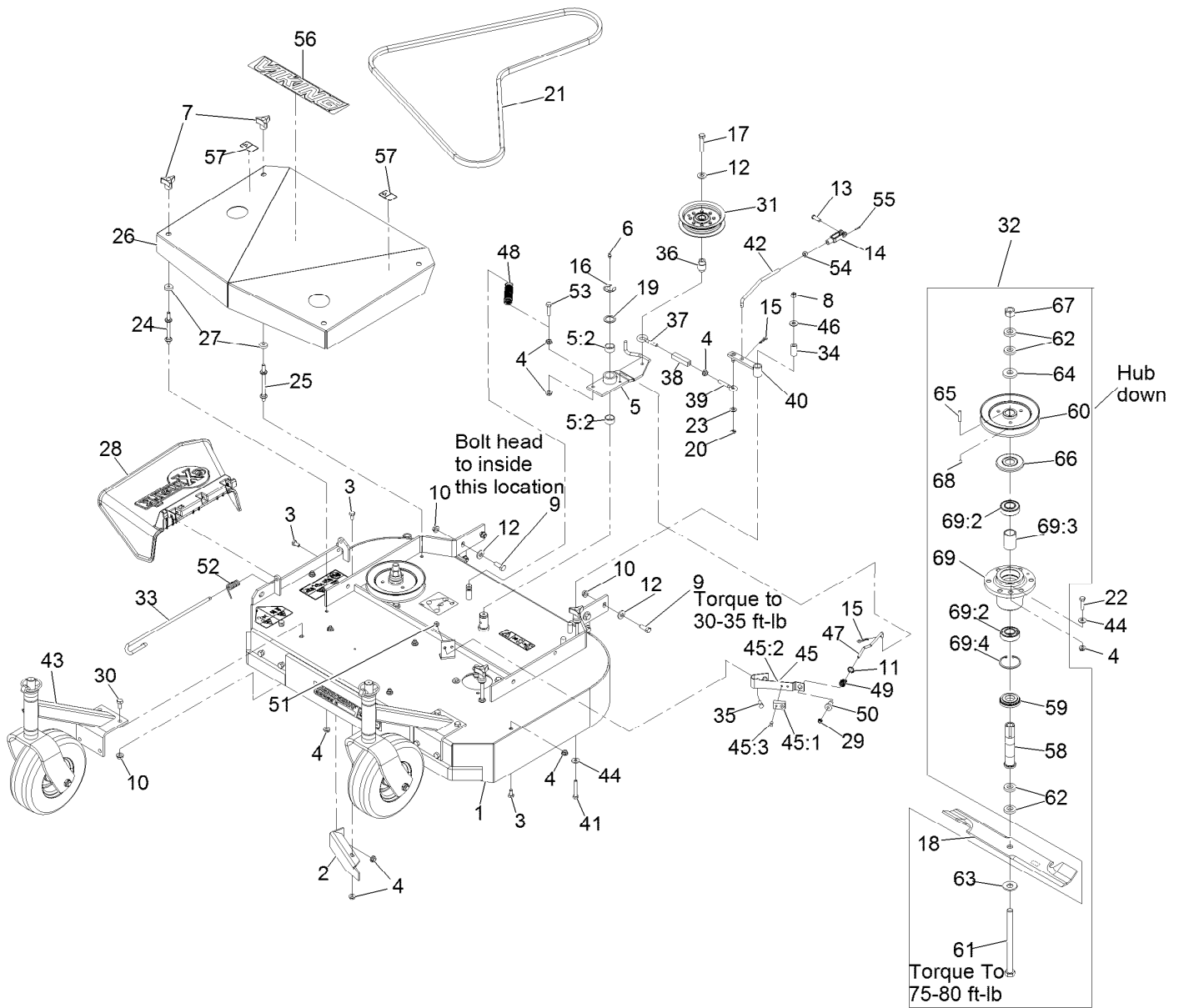

Deck Assembly (continued)

Ref.	Part Number	Qty.	Description	Ref.	Part Number	Qty.	Description
1	103-2312	1	Deck W/Decals And Dogleg	38	1-303236	1	Body-Turnbuckle
2	116-1730-01	1	Baffle-Dogleg	39	1-303238	1	Eyebolt-Thread, RH
3	322-2	7	Screw-HH 5/16-18 X 5/8	40	1-322235	1	Arm-Assist
4	32128-20	22	Nut-Whizlock 5/16-18	41	322-10	1	Screw-HH 5/16-18 X 2
5	103-3600	1	Idler Arm ASM	42	1-323174	1	Arm-Linkage, Assist
5:2	1-323729	2	Sleeve-Bearing	43	116-8245	2	ASM-Caster Mnt W/Weight
6	302-19	1	Zerk-1/4-28 Str	44	1-303334	9	Washer-Spring Disc 5/16
7	1-323385	4	Knob-3 Prong	45	1-324372	1	Pad And Spring ASM
8	3296-29	1	Nut-Nyloc 5/16-18	45:1	1-323709	1	Pad-Brake
9	323-6	8	Screw-HH 3/8-16 X 1	45:2	1-323710	1	Spring,Brakeserv By #324372
10	3290-357	8	Nut-Whizlock 3/8-16	45:3	103-0138	2	Rivet 3/16 X 1/2
11	1-323748	1	Ring-Push On	46	3256-3	1	Washer-5/16 Std
12	98-5975	9	Washer-Spring Disc 3/8	47	1-323715	1	Rod-Brake
13	1-808280	1	Pin-Clevis 5/16 X 1 49/64	48	1-323071	1	Spring-Extension
14	1-303105	1	Yoke-Adjustable	49	1-323747	1	Spring-Compression
15	1-806003	2	Hairpin-Cotter	50	1-323746	1	Spacer-Flanged
16	32151-103	1	E-Ring	51	3296-42	2	Nut-Nyloc 1/4-20
17	702809	1	Screw-HH	52	116-0962	1	Spring, Torsion
18	103-1578	2	Blade, Solid 18.00	53	116-3515	1	Screw,HH Special 5/16-18 X 1.25
18	103-6580	2	Blade, 18.00 Low Lift	54	3219-2	1	Nut-Hex 5/16-24
18	103-6582	2	Blade, 18.00 Mulching ▲	55	3272-5	1	Pin-Cotter 3/32 X 1/2
18	103-6584	2	Blade, 18.00 Notched	56	126-6891	1	Decal, Viking Hydro Model
18	116-5176	2	Blade-Extreme 2, 18.00"	57	106-5517	2	Decal-Warning, Hot Surface
19	1-303352	1	Washer-Spindle	58	1-323529	2	Tube-Spindle, Short ♦
20	32120-35	1	E-Ring	59	103-2535	2	Spacer-Guard Bottom
21	1-323735	1	Drive Belt (To Blades)	60	1-403183	2	Sheave ♦
22	322-6	8	Screw-HH 5/16-18 X 1 1/4	61	1-800861	2	Screw-Cap, HH
23	3256-23	1	Washer-5/16 Sae	62	1-323539	8	Spacer-Blade Drive
24	1-303537	2	Stud-Shield, Belt (Short)	63	1-513208	2	Washer-Spring Disc 5/8
25	1-303536	2	Stud-Shield, Belt (Long)	64	1-323339	2	Washer
26	116-2704	1	ASM,Shield W/Decals 36 Viking	65	1-807267	2	Key-Machine 1/4 X 3/16 X 1 1/4
27	1-323417	4	Washer-Belt Shield	66	103-1330	2	Guard-Bearing Top ♦
28	109-5151	1	Deflector-Discharge	67	3219-6	2	Nut-Hex 5/8-18
29	3296-56	1	Nut-Nyloc 1/4-20 Thin	68	3246-18	2	Setscrew-5/16-18 X 3/8 ■
30	323-4	8	Screw-HH 3/8-16 X 3/4	69		2	Cutter Housing ASM ●
31	116-3626	1	Pulley-Idler	69	103-8280	2	Asm, Cutter Housing W/Bearings ♦
32	103-8387	2	Asm, Cutter Housing Complete	69:2	103-2477	2	Bearing-Jackshaft
33	109-8854	1	Pin-Chute	69:3	103-2534	1	Spacer-Bearing
34	1-403179	1	Tube-Pivot	69:4	32120-8	1	Ring-Retaining
35	321-4	2	Screw-HH 1/4-20 X 3/4				
36	1-303434	1	Bushing-Engagement				
37	1-303348	1	Eyebolt-Thread, LH				

● Not serviced separately

■ Use Pro-Lock, Nut Type (P/N 1-840022, .5ml tube) on threads.

▲ Requires installation of mulch kit for proper mulching. See your Exmark dealer for details.

♦ Apply Mobil HTS grease (P/N 103-5217 1.5 oz packet) (or a food-grade anti-seize). See operator s manual for locations.

Deck W/Decals Assembly No. 103-2312

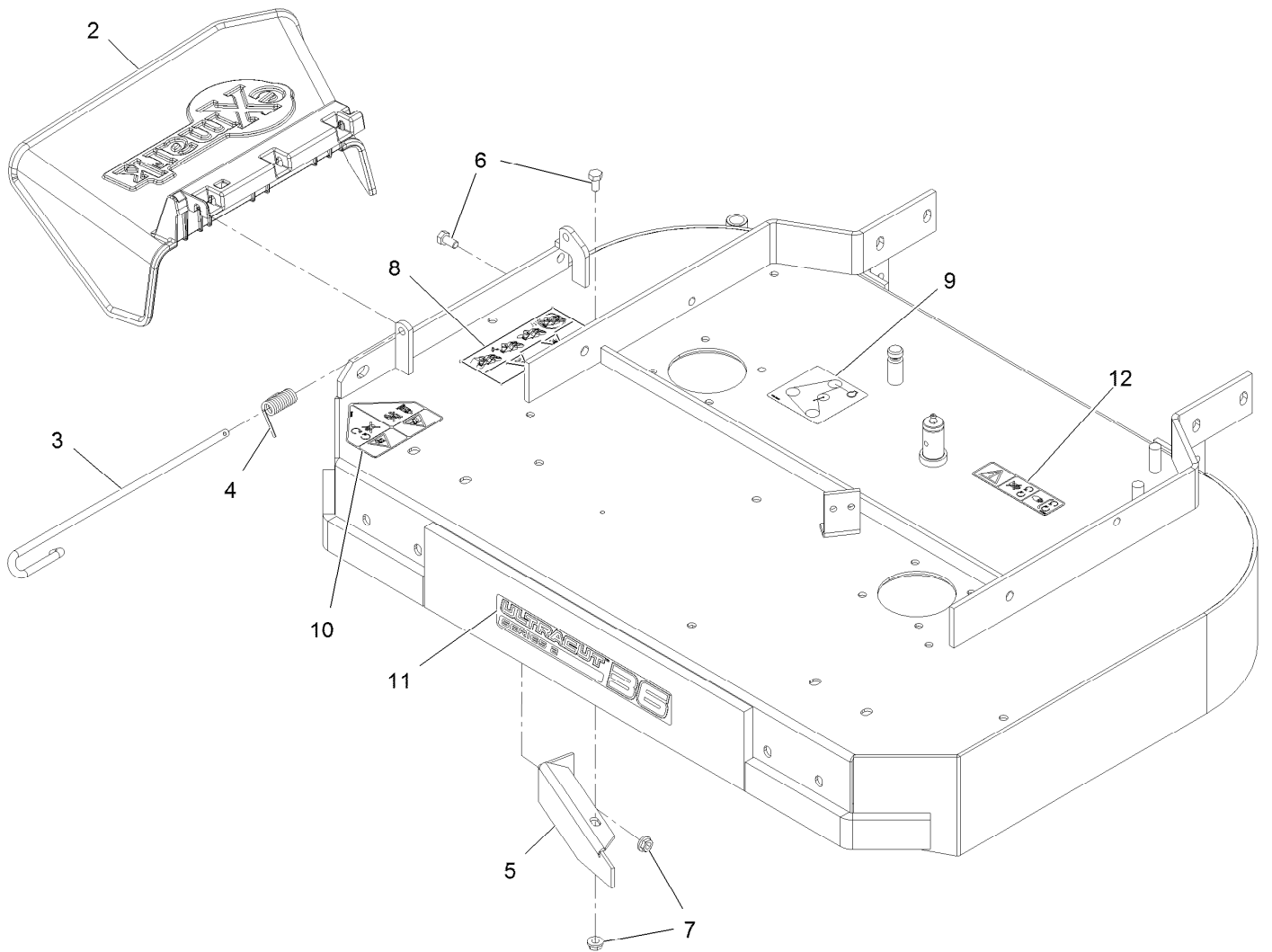

Deck W/Decals Assembly No. 103-2312 (continued)

<i>Ref.</i>	<i>Part Number</i>	<i>Qty.</i>	<i>Description</i>	<i>Ref.</i>	<i>Part Number</i>	<i>Qty.</i>	<i>Description</i>
2	109-5151	1	Deflector-Discharge	8	114-3489	1	Decal-Warning, Bagger
3	109-8854	1	Pin-Chute	9	116-7877	1	Decal-Belt Routing 32-36
4	116-0962	1	Spring, Torsion	10	112-8760	1	Decal-Danger
5	116-1730-01	1	Baffle-Dogleg	11	126-6742	1	Decal-Ultracut 36 Series 2
6	322-2	2	Screw-HH 5/16-18 X 5/8	12	112-9028	1	Decal-Missing, Cover
7	32128-20	2	Nut-Whizlock 5/16-18				

Caster Mount W/Weight Assembly No. 116-8245

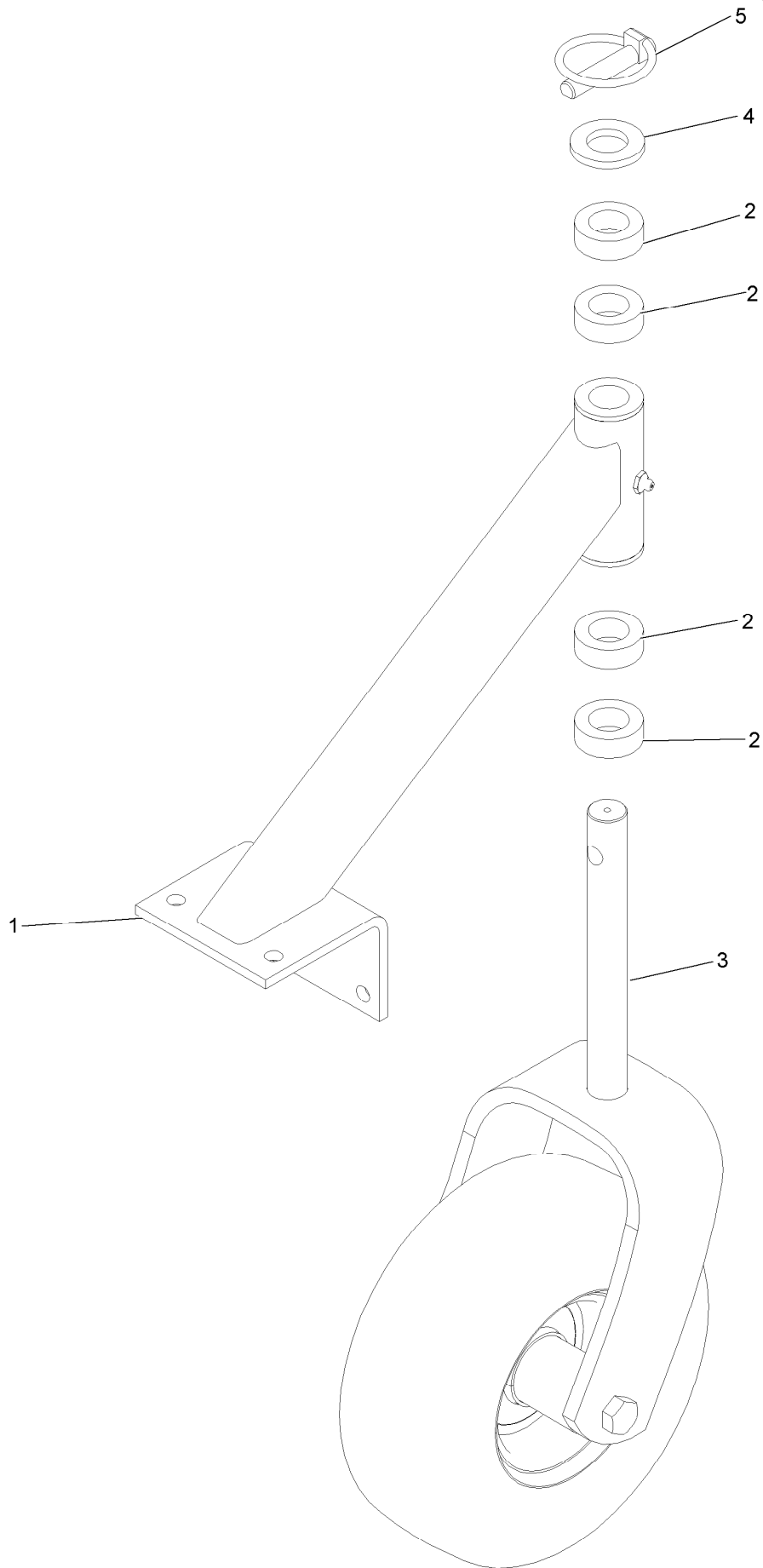

Caster Mount W/Weight Assembly No. 116-8245 (continued)

<i>Ref.</i>	<i>Part Number</i>	<i>Qty.</i>	<i>Description</i>	<i>Ref.</i>	<i>Part Number</i>	<i>Qty.</i>	<i>Description</i>
1	103-2296	1	Caster Whl Support W/Bearings, Weighted	3	103-1236	1	Caster Wheel Assembly
2	1-303314	4	Spacer-Caster	4	1-513338	1	Washer
				5	1-809020	1	Pin

Caster Wheel Support W/Bearings 103-2296

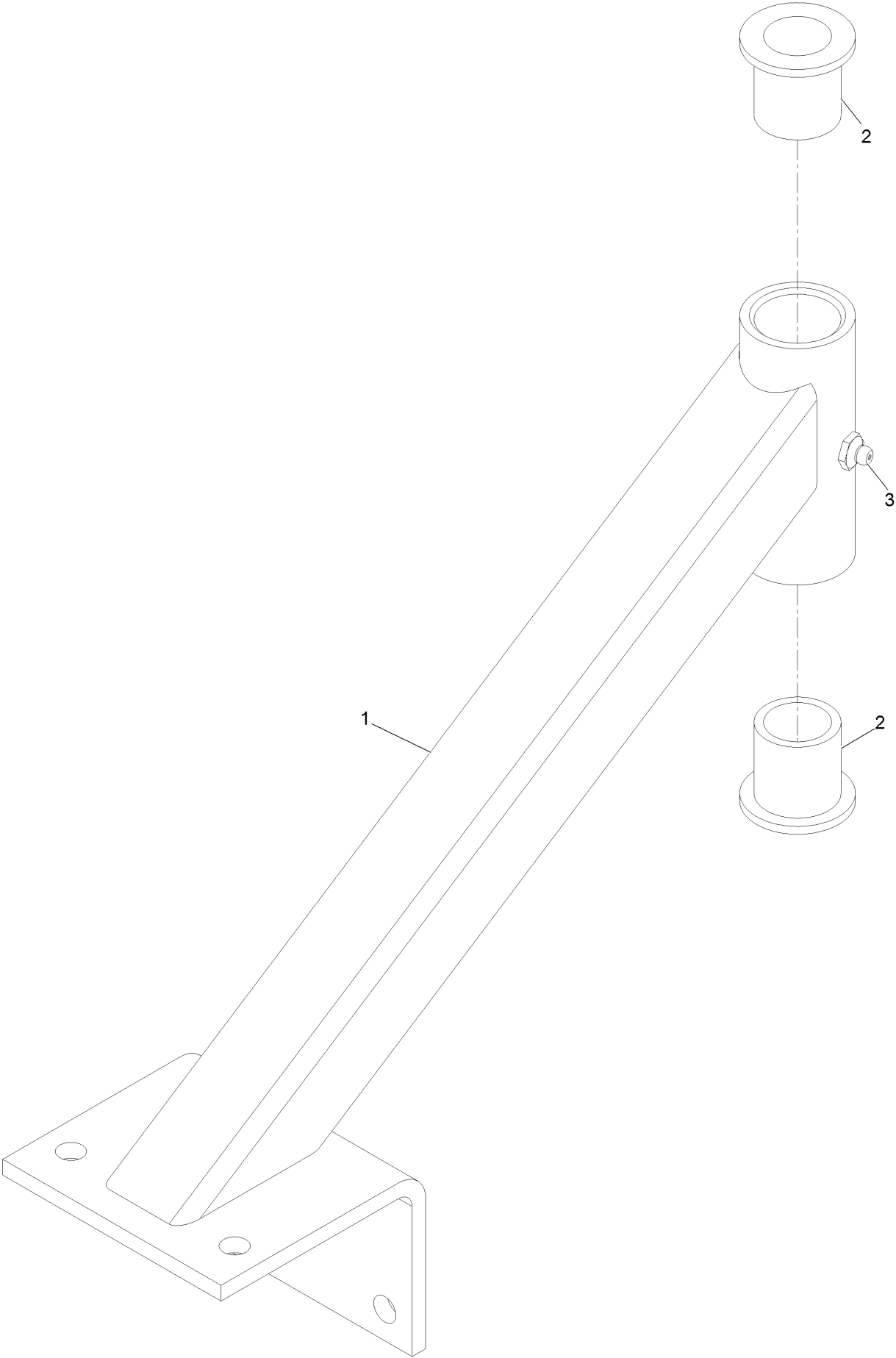

Caster Wheel Support W/Bearings 103-2296 (continued)

<i>Ref.</i>	<i>Part Number</i>	<i>Qty.</i>	<i>Description</i>
1	103-2297-01	1	Caster Whl Support Wldmnt, Weighted
2	1-303514	2	Bearing-Flanged
3	302-52	1	Fitting-Grease

Caster Wheel Assembly No. 103-1236

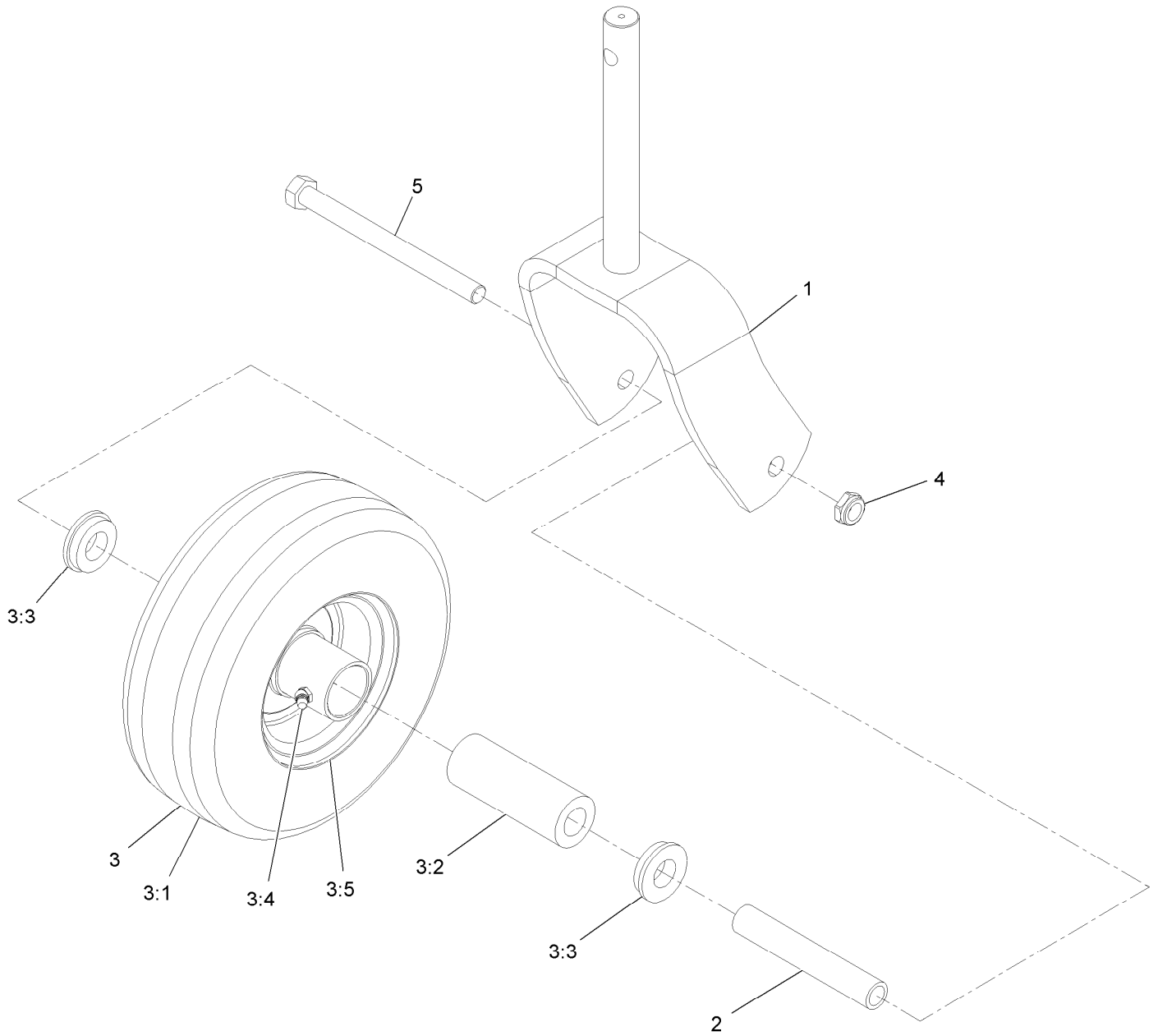

Caster Wheel Assembly No. 103-1236 (continued)

<i>Ref.</i>	<i>Part Number</i>	<i>Qty.</i>	<i>Description</i>	<i>Ref.</i>	<i>Part Number</i>	<i>Qty.</i>	<i>Description</i>
1	116-7942-01	1	Fork-Caster	3:3	1-513810	2	Bushing
2	1-513547	1	Spacer	3:4	302-61	1	Fitting-Grease
3	110-5023	1	Wheel And Tire ASM	3:5		1	Wheel ●
3:1		1	Tire ●	4	3296-45	1	Nut-Lock, NI
3:2	1-513809	1	Bearing	5	325-20	1	Screw-HH

● Not serviced separately

Engine Deck Assembly

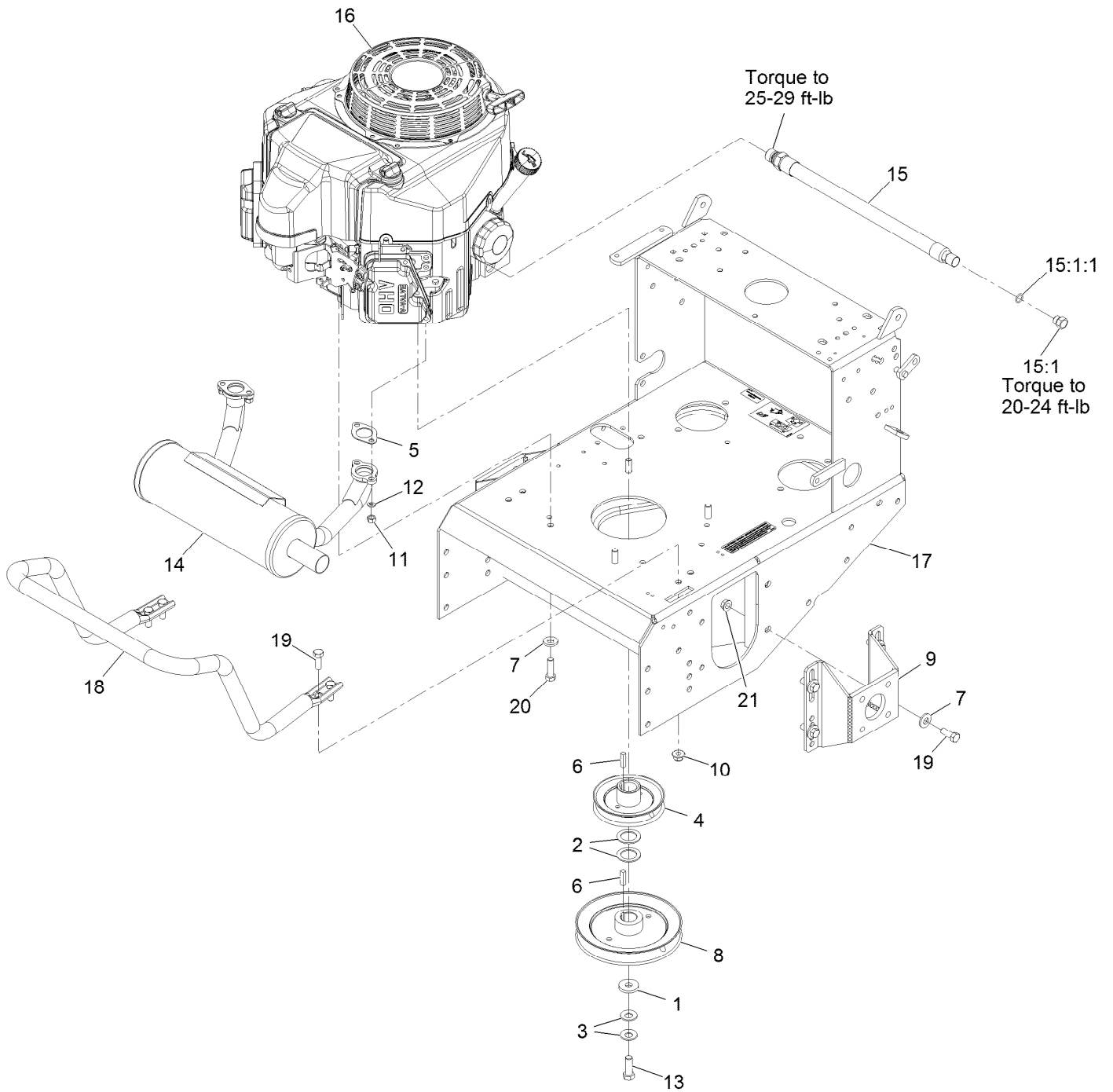

Engine Deck Assembly (continued)

<i>Ref.</i>	<i>Part Number</i>	<i>Qty.</i>	<i>Description</i>	<i>Ref.</i>	<i>Part Number</i>	<i>Qty.</i>	<i>Description</i>
1	1-373034	1	Washer	14	116-3734	1	Muffler-Horizontal, Offset
2	1-523157	2	Washer	15	116-5052	1	Asm-Oil Drain Hose W/Plug ▲
3	1-603610	2	Washer-Spring Disc 7/16	15:1	353-508	1	Plug-W/O-Ring
4	1-653035	1	Pulley	15:1:1	237-42	1	O-Ring
5	1-653313	2	Gasket-Exhaust	16		1	Engine-Kawasaki ●
6	1-807259	2	Key-Machine 1/4 X 1/4 X 1	17	116-6132	1	ASM, Vh Engine Deck W/Decals
7	98-5975	12	Washer-Spring Disc 3/8	18	116-6278-03	1	Guard-Muffler
8	103-1668	1	Sheave ■	19	323-6	12	Screw-HH 3/8-16 X 1
9	103-2289-01	2	Mount-Motor	20	323-7	4	Screw-HH 3/8-16 X 1 1/4
10	104-8301	4	Nut-Nyloc 3/8-16 Flg	21	3290-357	8	Nut-Whizlock 3/8-16
11	114-3549	4	Nut-M8				
12	114-3550	4	Washer-Lock				
13	116-3702	1	Screw-HH				

● Not serviced separately

▲ Use a Teflon Pipe Sealant or equivalent on threads.

■ Apply anti-seize compound in bore.

Engine Deck W/Decals Assembly No. 116-6132

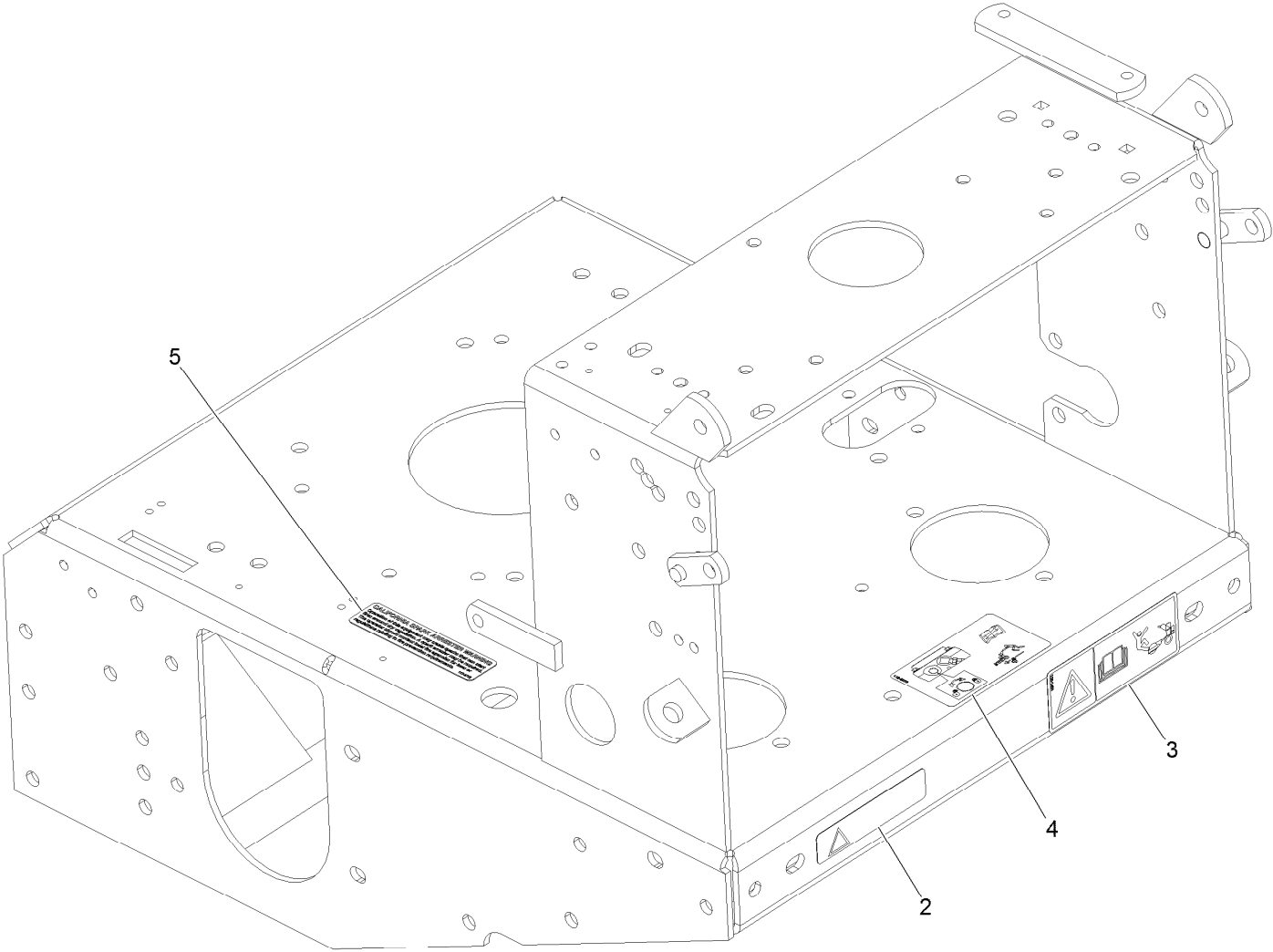

Engine Deck W/Decals Assembly No. 116-6132 (continued)

<i>Ref.</i>	<i>Part Number</i>	<i>Qty.</i>	<i>Description</i>
2	98-1977	1	Decal-Warning
3	126-1400	1	Decal-Warning, Sulky

<i>Ref.</i>	<i>Part Number</i>	<i>Qty.</i>	<i>Description</i>
4	116-8253	1	Decal-Drive Release
5	117-2718	1	Decal-Arrester, Spark

Engine Deck Assembly and Park Brake Assembly

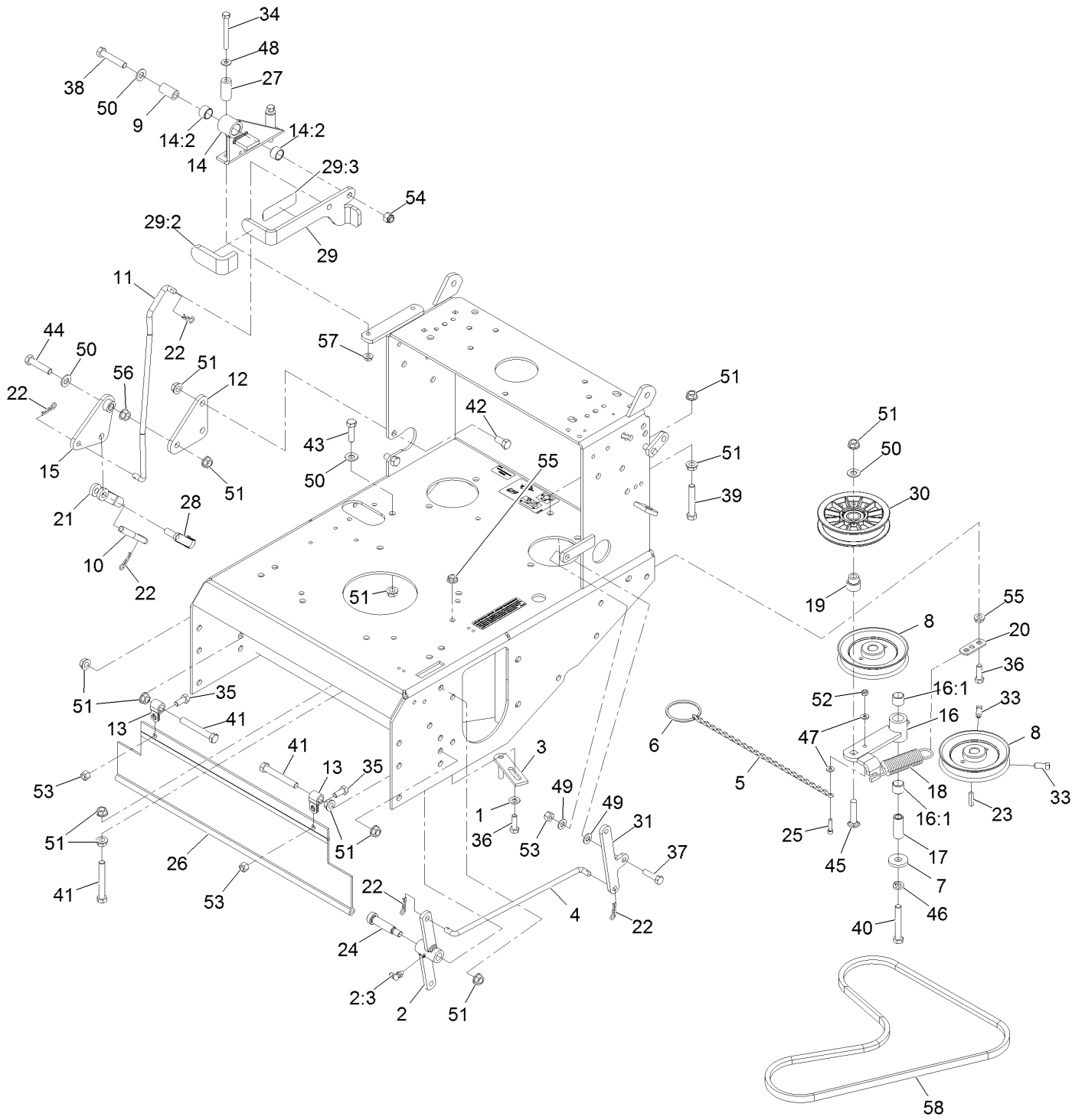

Engine Deck Assembly and Park Brake Assembly (continued)

<i>Ref.</i>	<i>Part Number</i>	<i>Qty.</i>	<i>Description</i>	<i>Ref.</i>	<i>Part Number</i>	<i>Qty.</i>	<i>Description</i>
1	1-303334	1	Washer-Spring Disc 5/16	29:2	1-303020	1	Grip-Lever
2	1-322108	1	Bellcrank ASM	29:3	116-7923	1	Decal-Parking Brake
2:3	302-40	1	Zerk-90° 1/4-28	30	109-4077	1	Pulley-Idler, Flat
3	1-322110	1	Guide-Belt	31	116-1737-01	1	Bellcrank
4	1-323172	1	Linkage-Engage, Blade	33	120-6474	4	Screw-Set, SQH 5/16-18 X 3/4
5	1-323365	1	Chain-Link, Twist	34	321-15	2	Screw-HH
6	1-323366	1	Ring-Split	35	322-3	2	Screw-HH 5/16-18 X 3/4
7	1-373034	1	Washer	36	322-5	2	Screw-HH 5/16-18 X 1
8	1-413010	2	Sheave ASM	37	322-6	1	Screw-HH 5/16-18 X 1 1/4
9	1-413344	1	Bushing-Pivot	38	323-10	1	Screw-HH 3/8-16 X 2
10	1-413489	1	Linkage-Lower	39	323-11	1	Screw-HH 3/8-16 X 2 1/4
11	1-413496	1	Linkage-Upper	40	323-12	1	Screw-HH 3/8-16 X 2 1/2
12	1-413497	1	Bellcrank	41	323-13	3	Screw-HH 3/8-16 X 2 3/4
13	1-413510	2	Clip-Loom	42	323-4	2	Screw-HH 3/8-16 X 3/4
14	1-414504	1	Bracket ASM	43	323-7	1	Screw-HH 3/8-16 X 1 1/4
14:2	1-413347	2	Sleeve-Bushing	44	323-9	1	Screw-HH 3/8-16 X 1 3/4
15	1-414508	1	Bellcrank ASM	45	3231-29	1	Bolt-Carriage 3/8-16 X 1 3/4
16	1-602521	1	Idler Arm ASM	46	3253-5	1	Washer-Lock 3/8 Heavy
16:1	103-4681	2	Sleeve-Bearing	47	3256-14	2	Washer-#10 Std
17	1-603044	1	Bushing	48	3256-22	2	Washer-1/4 Sae
18	1-603402	1	Spring-Extension	49	3256-23	2	Washer-5/16 Sae
19	1-603496	1	Bushing-Idler	50	3256-24	4	Washer-3/8 Sae
20	1-603801	1	Anchor-Spring	51	3290-357	14	Nut-Whizlock 3/8-16
21	1-633131	1	Yoke-Linkage, Brake	52	3296-2	1	Nut-Nyloc #10-24
22	1-806003	5	Hairpin-Cotter	53	3296-29	3	Nut-Nyloc 5/16-18
23	1-807272	2	Key-5Mm X 5Mm X 25Mm	54	3296-39	1	Nut-Nyloc 3/8-16
24	1-809062	1	Screw	55	32128-20	5	Nut-Whizlock 5/16-18
25	1-809069	1	Screw-HSH #10-24 X 7/8	56	32128-21	1	Nut-3/8-16 Flanged Side Lock
26	103-2056	1	Shield-Drag	57	32128-33	2	Nut-Whizlock 1/4-20
27	103-2191	2	Spacer	58	103-4760	1	Belt-Cog
28	103-2399	1	Pin-Clevis Spring 3/8				
29	103-3495	1	Lever, Park Brake W/Decals				

Engine Deck and Speed Control Assembly

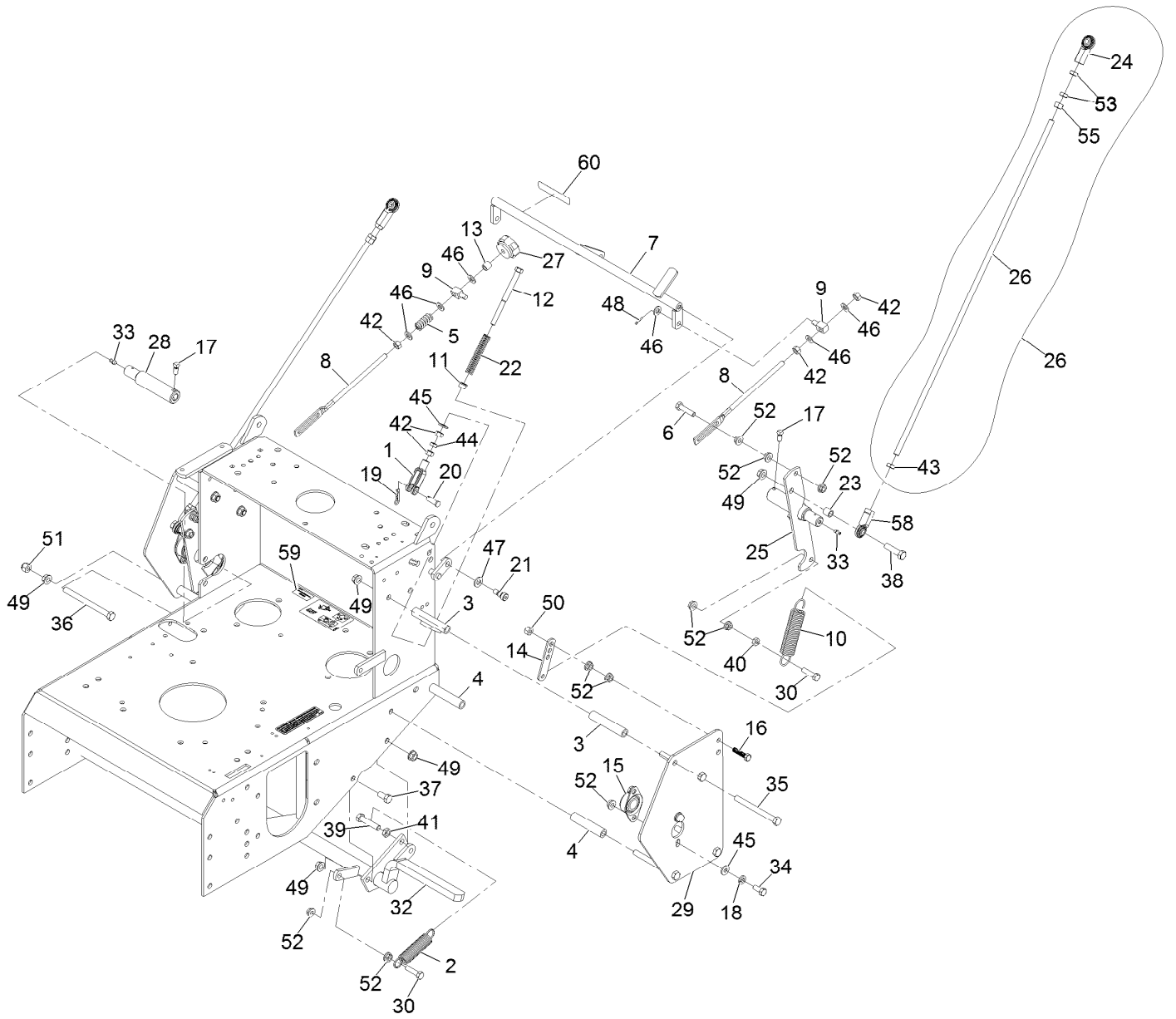

Engine Deck and Speed Control Assembly (continued)

<i>Ref.</i>	<i>Part Number</i>	<i>Qty.</i>	<i>Description</i>	<i>Ref.</i>	<i>Part Number</i>	<i>Qty.</i>	<i>Description</i>
1	1-303105	2	Yoke-Adjustable	29	110-4897-01	2	Shield-Control
2	1-323161	1	Spring	30	116-3515	3	Screw,HH Special 5/16-18 X 1.25
3	1-323195	4	Standoff, Clutch	32	126-1599	1	Shaft-Cross, Brake
4	1-323197	4	Spacer,Shield	33	302-19	2	Zerk-1/4-28 Str
5	1-323245	1	Spring-Compression	34	322-3	4	Screw-HH 5/16-18 X 3/4
6	1-403180	2	Screw-HH 5/16-18 X 1 3/8 Special	35	323-16	7	Screw-HH 3/8-16 X 4
7	1-412203-01	1	Crank-Control, Speed	36	323-23	1	Screw-HH 3/8-16 X 4-1/2
8	1-413350	2	Link-Control, Speed	37	323-4	3	Screw-HH 3/8-16 X 3/4
9	1-603676	2	Swivel-Adjustable, Short	38	323-8	2	Screw-HH 3/8-16 X 1 1/2
10	1-603693	2	Spring	39	323-9	1	Screw-HH 3/8-16 X 1 3/4
11	1-603735	2	Bushing-Flanged	40	3218-2	2	Nut-Jam 5/16-18
12	1-603737	2	Bolt-Neutral Return	41	3218-3	1	Nut-Jam 3/8-16
13	1-603903	1	Spacer	42	3219-2	7	Nut-Hex 5/16-24
14	1-613089	2	Tab-Spring, Extension	43	3220-16	2	Nut-Jam 3/8-24 LH
15	1-633102	2	Bearing-Flanged	44	3220-2	2	Nut-Jam 5/16-24
16	1-800016	2	Bolt-HH 5/16-18 X 1 1/4 Tap	45	3256-2	6	Washer-1/4 Std
17	1-803022	2	Setscrew-5/16-18 X 5/8	46	3256-23	6	Washer-5/16 Sae
18	1-805005	4	Washer-Lock 5/16 Heavy	47	3256-24	2	Washer-3/8 Sae
19	1-806003	2	Hairpin-Cotter	48	3272-5	1	Pin-Cotter 3/32 X 1/2
20	1-808280	2	Pin-Clevis 5/16 X 1 49/64	49	3290-357	14	Nut-Whizlock 3/8-16
21	1-809056	2	Screw-Sh 5/16-18 X 1 3/8	50	3296-29	2	Nut-Nyloc 5/16-18
22	103-0265	2	Spring, Neutral Return	51	3296-39	1	Nut-Nyloc 3/8-16
23	103-1166	2	Spacer-Tube, Pump Link	52	32128-20	20	Nut-Whizlock 5/16-18
24	103-2463	2	Balljoint	53	3220-3	4	Nut-Jam 3/8-24
25	103-1190-01	1	Shaft-Control, LH	55	3219-3	2	Nut-Hex 3/8-24
26	103-1734	2	Linkage, Drive	58	103-1167	2	Joint-Ball End
26	116-3415	2	Drive Link ASM	59	126-4345	1	Decal-Patent Ttco.Com
27	103-3060	1	Knob-Tracking	60	116-7918	1	Decal-Tracking Adjustment
28	103-4796-01	1	Shaft-Control, RH				

Controls Assembly

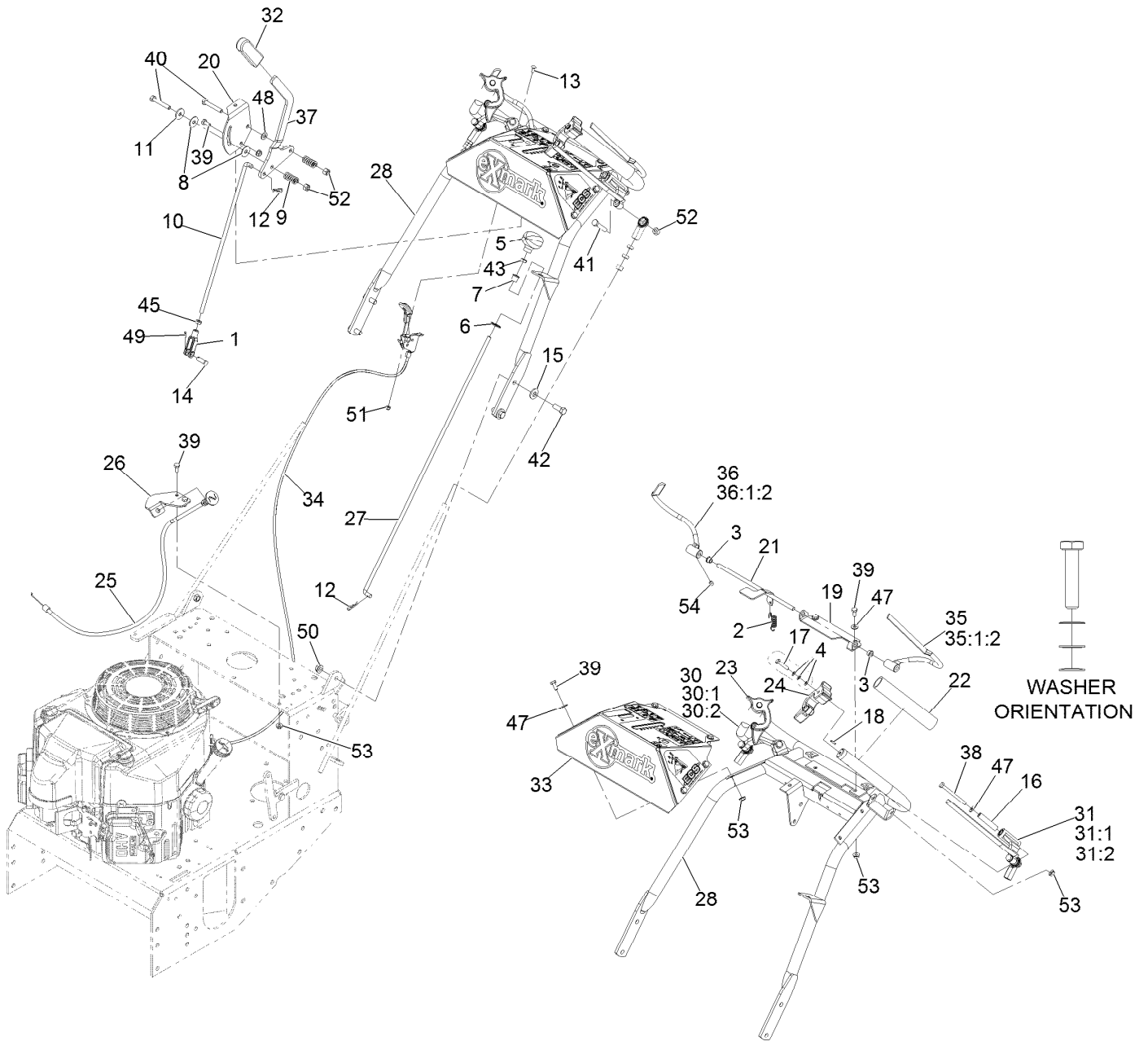

Controls Assembly (continued)

<i>Ref.</i>	<i>Part Number</i>	<i>Qty.</i>	<i>Description</i>	<i>Ref.</i>	<i>Part Number</i>	<i>Qty.</i>	<i>Description</i>
1	1-303105	1	Yoke-Adjustable	30	103-2513	1	Asm, Drive Lever RH
2	1-303363	1	Spring-Extension	30:1	116-4082	1	Wld,RH Drive Lever
3	1-303365	2	Bushing-Nylon	30:2	1-413152	2	Bushing-Sleeve
4	1-303435	6	Washer-Spring Disc 1/4	31	103-2514	1	Asm, Drive Lever LH
5	1-323134	1	Knob-Push / Pull	31:1	116-4081	1	Wld,LH Drive Lever
6	1-323142	1	Nut-Push 1/2	31:2	1-413152	2	Bushing-Sleeve
7	1-323143	1	Bearing-Nylon	32	103-5994	1	Grip-Handle, Steering
8	1-323244	2	Washer-Friction	33	109-4931	1	Asm, Console W/Decals
9	1-323245	2	Spring-Compression	34	116-2426	1	Control, Throttle
10	1-323522	1	Rod-Control, Speed	35	116-4079	1	Wld,LH Opc Lever
11	1-603716	1	Washer-Friction Disc	35:1:2	1-803322	1	Setscrew-5/16-24 X 5/16 ●
12	1-806003	2	Hairpin-Cotter	36	116-4080	1	Wld,RH Opc Lever
13	1-807513	2	Bolt-Carriage #10-24 X 1/2	36:1:2	1-803322	1	Setscrew-5/16-24 X 5/16 ●
14	1-808280	1	Pin-Clevis 5/16 X 1 49/64	37	116-7682	1	Lever-Shift
15	98-5975	4	Washer-Spring Disc 3/8	38	321-14	2	Screw-HH 1/4-20 X 2 3/4
16	103-0027	2	Bushing-Lever, Drive	39	321-3	11	Screw-HH 1/4-20 X 5/8
17	103-0235	2	Screw-HH 1/4-20 X 1 1/8 W/Nylon	40	322-10	2	Screw-HH 5/16-18 X 2
18	126-2925	2	Pin-Spring	41	322-9	2	Screw-HH 5/16-18 X 1 3/4
19	103-0489-03	1	Bracket, Opc Axle	42	323-6	4	Screw-HH 3/8-16 X 1
20	103-0503	1	Bracket,Shifter Slide	43	3218-2	1	Nut-Jam 5/16-18
21	103-0769-03	1	Rod Weldment, Opc	45	3220-2	1	Nut-Jam 5/16-24
22	103-0815	2	Grip-Bar, Handle	47	3256-22	10	Washer-1/4 Sae
23	103-1371	1	Thumb Latch Asm RH	48	3256-23	1	Washer-5/16 Sae
24	103-1372	1	Thumb Latch Asm LH	49	3272-5	1	Pin-Cotter 3/32 X 1/2
25	103-1796	1	Cable-Choke	50	3290-357	4	Nut-Whizlock 3/8-16
26	103-1797	1	Bracket,Choke Cable Mtg (Raw)	51	3296-2	2	Nut-Nyloc #10-24
27	103-2193	1	Link, Blade Engagement	52	3296-29	4	Nut-Nyloc 5/16-18
28	103-2194-03	1	Handle Wld, Upper Ecs	53	32128-33	13	Nut-Whizlock 1/4-20
				54	1-803322	2	Setscrew-5/16-24 X 5/16

● Use Pro-Lock, Nut Type (P/N 1-840022, .5ml tube) on threads.

Control Panel W/Decals Assembly No. 109-4931

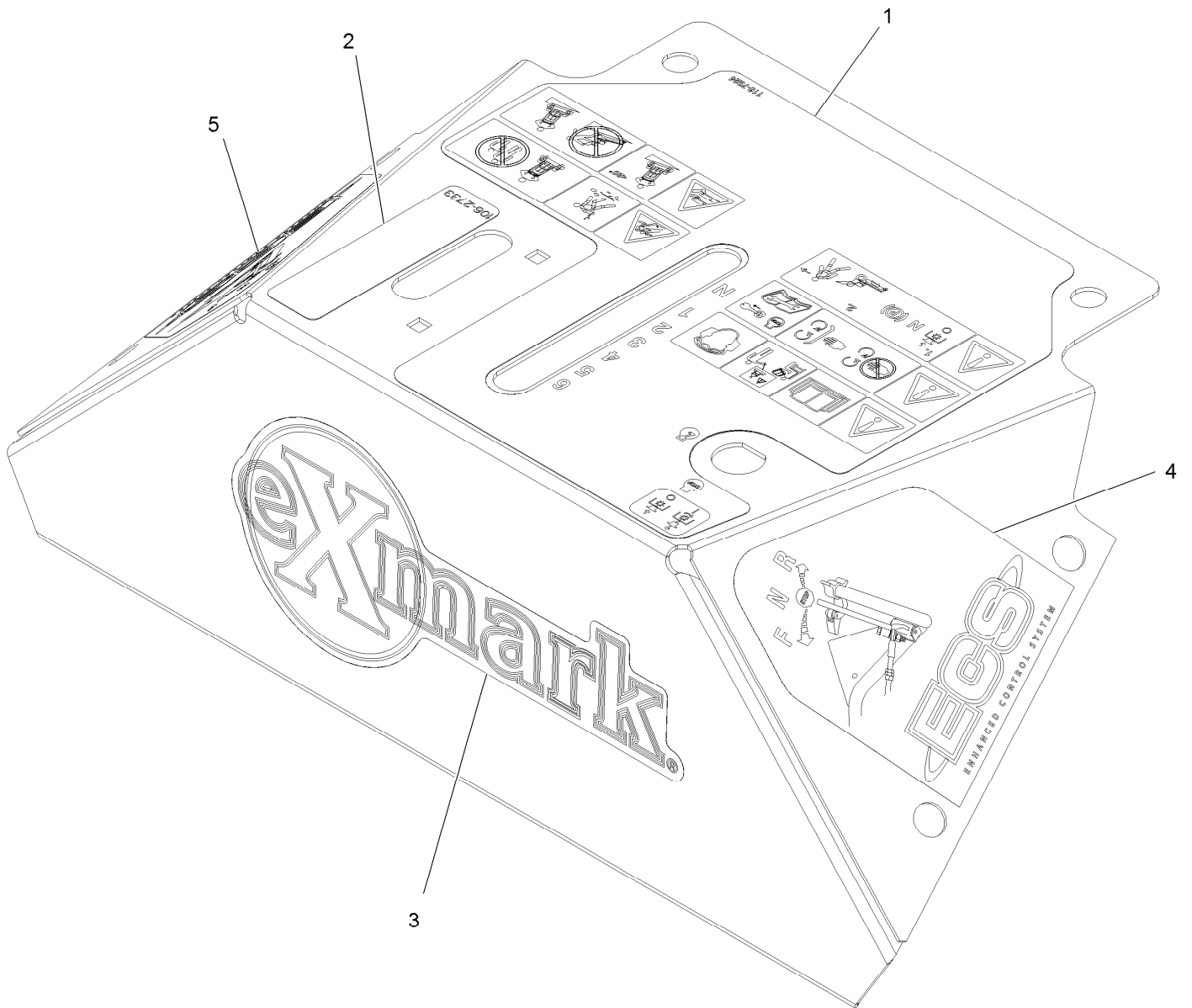

Control Panel W/Decals Assembly No. 109-4931 (continued)

<i>Ref.</i>	<i>Part Number</i>	<i>Qty.</i>	<i>Description</i>	<i>Ref.</i>	<i>Part Number</i>	<i>Qty.</i>	<i>Description</i>
1	116-7924	1	Decal-Console Vh Ecs	4	103-2242	1	Decal, Ecs Instruction LH
2	106-2733	1	Decal-Throttle	5	103-2243	1	Decal, Ecs Instruction RH
3	126-6877	1	Decal, Exmark Logo				

Fuel Tank Assembly

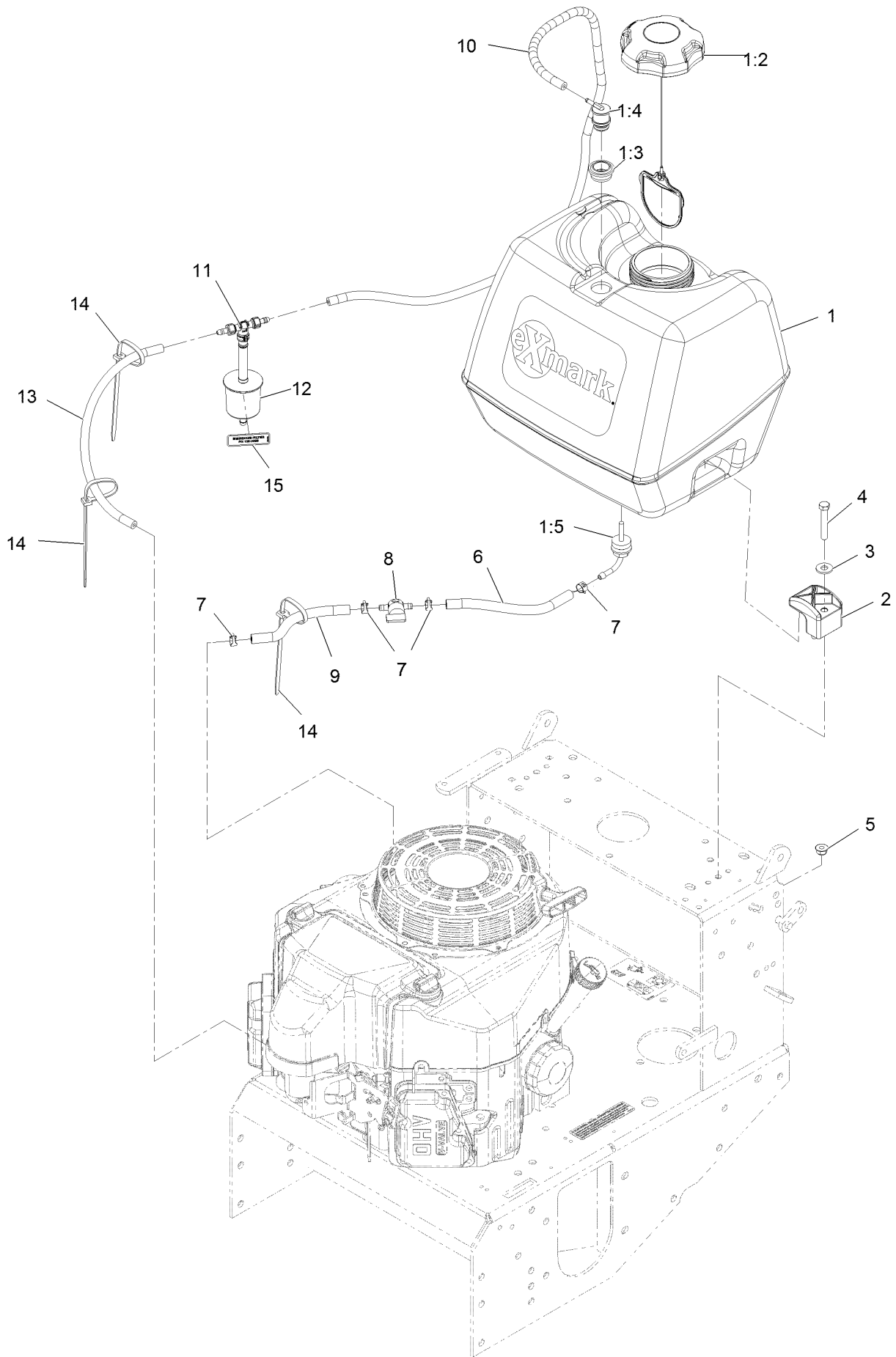

Fuel Tank Assembly (continued)

<i>Ref.</i>	<i>Part Number</i>	<i>Qty.</i>	<i>Description</i>	<i>Ref.</i>	<i>Part Number</i>	<i>Qty.</i>	<i>Description</i>
1	126-1525	1	ASM, Fuel Tank	7	2412-98	4	Clamp-Hose
1:2	120-5461	1	Cap-Fuel, Ratcheting	8	1-603770	1	Valve-Fuel
1:3	114-0284	1	Grommet	9	99-9415	1	Hose-Fuel
1:4	119-3547	1	Valve-Vent, Fuel	10	116-4346	1	Hose-Emissions
1:5	103-2605	1	Fitting-Fuel Bulkhead W/Strainer ♦	11	116-5464	1	Tee And Check
2	107-4543	2	Clamp	12	120-2235	1	Filter-Fuel
3	3256-3	2	Washer-Flat	13	115-7872	1	Hose-Fuel
4	322-10	2	Screw-HH	14	1-303335	3	Tie-Plastic
5	104-8300	2	Nut-Nyloc 5/16-18 Flg	15	116-4769	1	Decal-Filter, Emissions
6	109-0650	1	Hose-Fuel	16		1	Pn 41019-1055 Filter W/6In Fuel Line ●■▲

● Not illustrated

▲ Obtain parts from www.kawpowerepc.com

♦ Use Pro-Lock, Nut Type (P/N 1-840022, .5ml tube) on threads.

■ Not serviced separately

Hydraulic Assembly

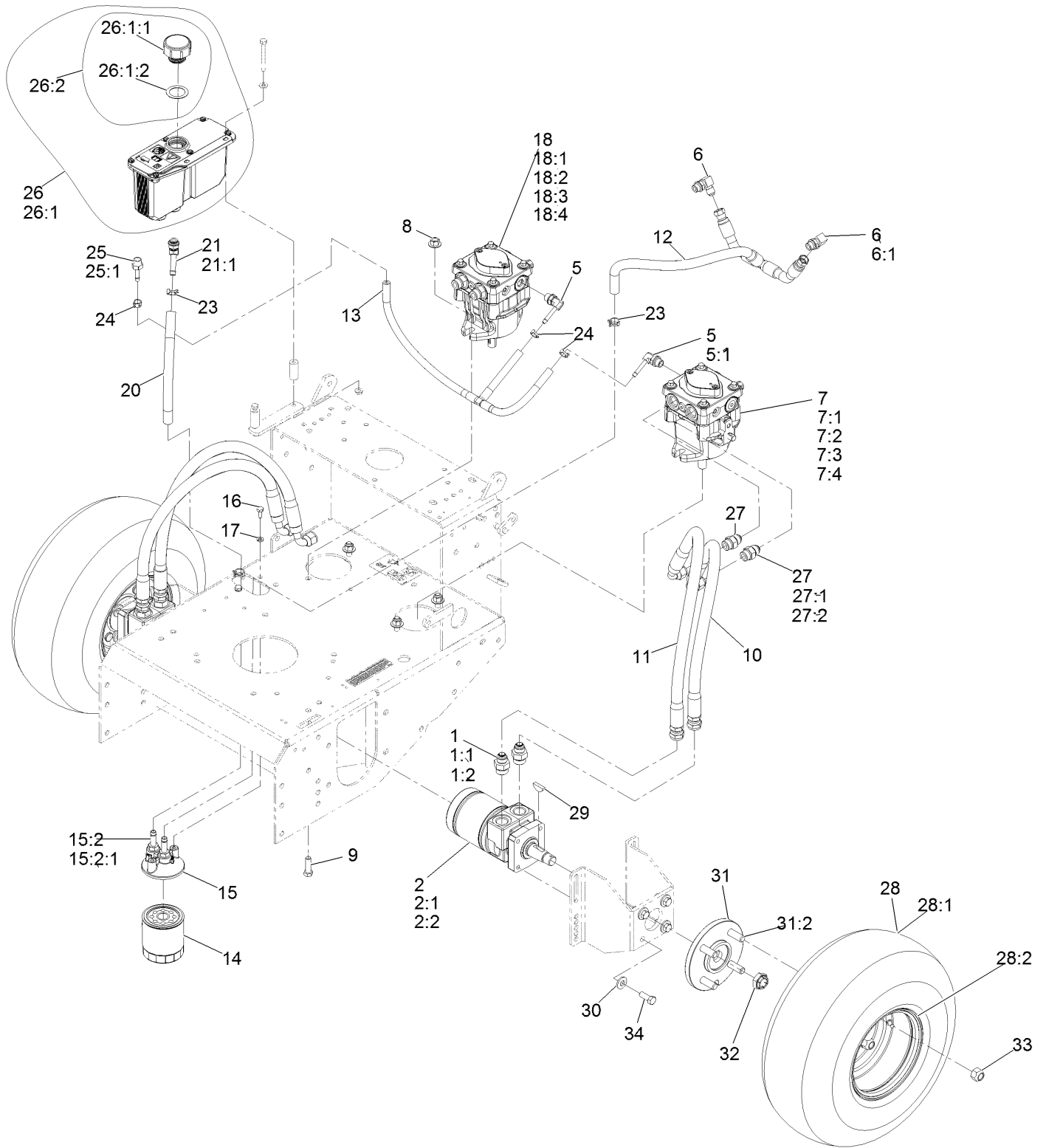

Hydraulic Assembly (continued)

<i>Ref.</i>	<i>Part Number</i>	<i>Qty.</i>	<i>Description</i>	<i>Ref.</i>	<i>Part Number</i>	<i>Qty.</i>	<i>Description</i>
1	1-603991	4	Adapter-Straight	18:1	103-2664	1	Input Shaft Kit
1:1	237-80	1	O-Ring	18:2	94-6922	1	Bearing-Thrust
1:2	1-603992	1	O-Ring-37 Flare #8	18:3	103-2666	1	Cylinder Block Kit
2	1-603718	2	HYD Motor ASM	18:4	105-6184	1	Seal Overhaul Kit
2:1	1-000119	1	Seal Kit	20	103-2959	1	Hose-Charge
2:2	1-000138	1	Bearing And Seal Kit	21	103-1807	1	Fitting-Barbed, 45 DEG
5	103-1799	2	Elbow-90 DEG	21:1	237-42	1	O-Ring
5:1	237-42	1	O-Ring	23	103-1988	3	Clamp-Hose 11/16
6	103-1802	2	Fitting-HYD, 90 DEG	24	103-1716	3	Clamp-Hose 17/32
6:1	1-603921	1	O-Ring-Sae #6	25	103-1801	1	Adapter-Straight
7	116-0942	1	LH HYD Pump ASM	25:1	237-42	1	O-Ring
7:1	103-2664	1	Input Shaft Kit	26	126-1248	1	ASM, HYD Reservoir
7:2	94-6922	1	Bearing-Thrust	26:1		1	Reservoir-HYD ●
7:3	103-2666	1	Cylinder Block Kit	26:1:1	103-1948	1	Cap-Reservoir, HYD
7:4	105-6184	1	Seal Overhaul Kit	26:1:2	103-1949	1	Gasket-Cap
8	32128-43	4	Nut-Whizlock 3/8-16	26:2	115-4212	1	Decal-Warning
9	323-7	4	Screw-HH 3/8-16 X 1 1/4	27	1-603990	4	Fitting-Straight
10	119-7827	2	HYD Hose ASM	27:1	1-603920	1	O-Ring-Sae #8
11	119-7826	2	HYD Hose ASM	27:2	1-603992	1	O-Ring-37 Flare #8
12	116-2123	1	Charge Hose ASM	28	1-413473	2	Wheel And Tire ASM
13	116-0918	1	Case Drain Hose ASM	28:1	1-413474	1	Tire-Turfmaster
14	1-523541	1	Element, Oil Filter (Winter) ■	28:2	1-603715	1	Wheel-Rim
14	109-4180	1	Element, Oil Filter	29	1-807019	2	Key-Woodruff 1 X 1/4
15	103-2889	1	Filter Head ASM	30	98-5975	8	Washer-Spring Disc 3/8
15:2	103-1912	2	Adapter-Straight	31	112-9049	2	Wheel Hub ASM
15:2:1	237-42	1	O-Ring	31:2	1-633926	4	Stud-Wheel
16	321-3	2	Screw-HH 1/4-20 X 5/8	32	116-2839	2	Nut-Lock
17	1-805004	2	Washer-Lock 1/4 Heavy	33	242-50	8	Nut-Lug 1/2-20
18	116-0943	1	RH HYD Pump ASM	34	323-6	8	Screw-HH 3/8-16 X 1

● Not serviced separately

■ Use only for operation below 32°F (0°C).

Electrical Assembly

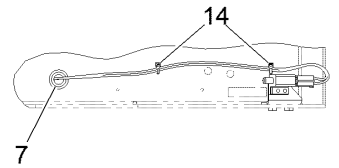
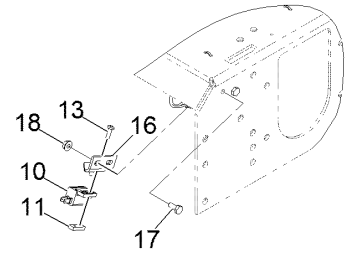
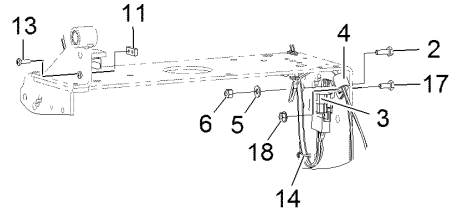
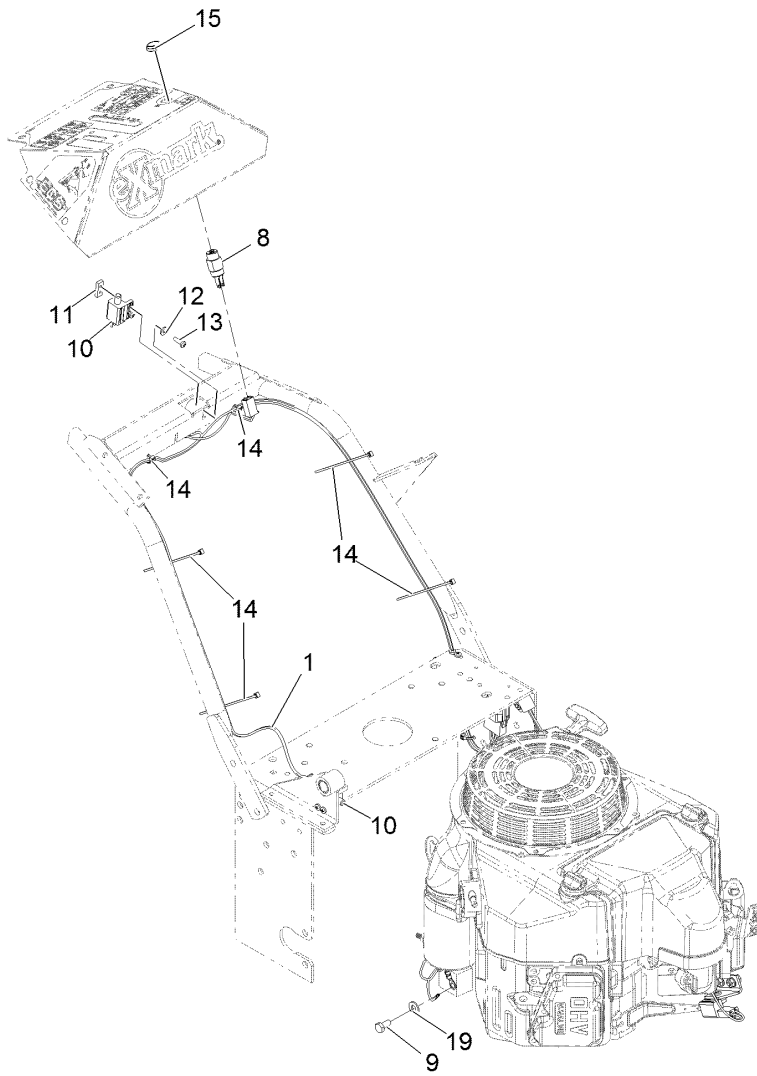

Electrical Assembly (continued)

<i>Ref.</i>	<i>Part Number</i>	<i>Qty.</i>	<i>Description</i>	<i>Ref.</i>	<i>Part Number</i>	<i>Qty.</i>	<i>Description</i>
1	116-2611	1	Harness-Wiring ●	10	1-513051	4	Switch-N.O.
2	321-4	1	Screw-HH 1/4-20 X 3/4	11	1-633181	4	Plate-Tapped
3	1-323430	1	Module-Interlock	12	3256-14	1	Washer-#10 Std
4	1-603727	1	Clip-Loom	13	3290-500	8	Screw-PPH #10-24 X 5/8
5	3256-22	2	Washer-1/4 Sae	14	1-303287	9	Tie-Cable 5 1/2 (Small)
6	3296-42	1	Nut-Nyloc 1/4-20	15	103-0498	1	Nut-Ignition
7	1-543296	1	Grommet	16	1-323213	1	Bracket-Switch, Blade
8	1-403121	1	Switch & Key (Includes Nut & Washer)	17	321-3	3	Screw-HH 1/4-20 X 5/8
9	33114-016	1	Screw-HH M8-1.25 X 16Mm	18	32128-33	3	Nut-Whizlock 1/4-20
				19	33094-00	1	Washer

● Use dielectric grease on all unsealed connectors and terminals only. Do not apply in sealed connectors.

Notes:



MAXIMIZE THE PERFORMANCE OF YOUR EXMARK MACHINE.



EXMARK® PREMIUM ENGINE OIL

Exmark now offers a family of engine oil viscosities to perform well in any environment. Each viscosity has the same synthetic formulation to give you what you need in punishing conditions. We designed each grade to the highest quality, making it ideal even for diesel applications. Coupled with Exmark Premium Fuel Treatment, we have the performance products to make your machine hum.

EXMARK PREMIUM ENGINE OIL SAE 30/10W-30

- Meets zero shear requirements of a straight grade SAE 30 as well as the cold temp properties of a 10W-30.
- Most versatile oil in the industry.
- Superior corrosion protection over conventional oil - even in corrosive, humid environments.

EXMARK PREMIUM ENGINE OIL SAE 20W-50

- Perfect for your big block engine, or any application in severe service.
- Same full synthetic formulation as all other Exmark Premium viscosities.
- Also effective for use in severe service small block engines.

EXMARK PREMIUM ENGINE OIL SAE 10W-50

- Full synthetic formulation gives you peak performance. Don't settle for less.
- Wide span multi-grade combines easy starting in cold weather with maximum protection in high temperature operation.
- Reduce friction & wear over standard mineral formulations.

EXMARK PREMIUM ENGINE OIL SAE 0W-40

- The perfect choice for when the weather turns cold or unpredictable, and your Exmark UTV has to perform.
- Commercial quality for severe service.
- Advanced additive package helps prevent corrosion from long-term storage.

EXMARK PREMIUM ENGINE OIL UTV FORMULATION

- 4-cycle high-temp formulation.
- Heavier viscosity, full synthetic, perfect for your UTV.

EXMARK PREMIUM UTV EXTREME CONDITIONS GEAR OIL

- SAE 80W-90, designed to keep your UTV performing at its peak.
- Shear stable, hypoid gear lube.
- Includes a premium additive system to combat wear, oxidation, rust & corrosion.

Available from your local Exmark dealer. Find your closest dealer at exmark.com

EXMARK ACCESSORIES AND OPTIONS*

MID-MOUNT RIDING ACCESSORIES AND OPTIONS

CUSTOM RIDE SEAT SUSPENSION SYSTEM	OPERATOR CONTROLLED DISCHARGE
FULL SUSPENSION SEAT	SUN SHADE
DECK LIFT ASSIST KIT	TRASH CONTAINER
HITCH KIT	TURF STRIPER
LIGHT KIT	ULTRA VAC COLLECTION SYSTEM
12V POWER PORT	ULTRA VAC QUICK DISPOSAL SYSTEM
MICRO-MULCH SYSTEM	

OUT-FRONT RIDING ACCESSORIES AND OPTIONS

CUSTOM RIDE SEAT SUSPENSION SYSTEM	SNOW BLADE
DUAL-TAIL WHEEL	SNOWBLOWER
FLOOR PAN EXTENDER	SUN SHADE
HITCH KIT	TRASH CONTAINER
LIGHT KIT	ULTRA VAC COLLECTION SYSTEM
MICRO-MULCH SYSTEM	ULTRA VAC QUICK DISPOSAL SYSTEM
ROLL OVER PROTECTION SYSTEM (ROPS)	WEATHER CAB

WALK-BEHIND ACCESSORIES AND OPTIONS

GRASS CATCHER	TURF STRIPER
MICRO-MULCH SYSTEM	STANDON

*Some accessories and options not available for some models.

Place Model No. and Serial No.
Label Here (Included in the Literature
Pack) or Fill in Below

Model No. _____

Serial No. _____

Date Purchased _____

Engine Model No. and Spec. No. _____

Engine Serial No. (E/No) _____

© 2015 Exmark Mfg. Co., Inc.
Industrial Park Box 808
Beatrice, NE 68310
All Rights Reserved

Part No. 4502-568 Rev. A
(402) 223-6300
Fax (402) 223-5489
Printed in the USA.

