

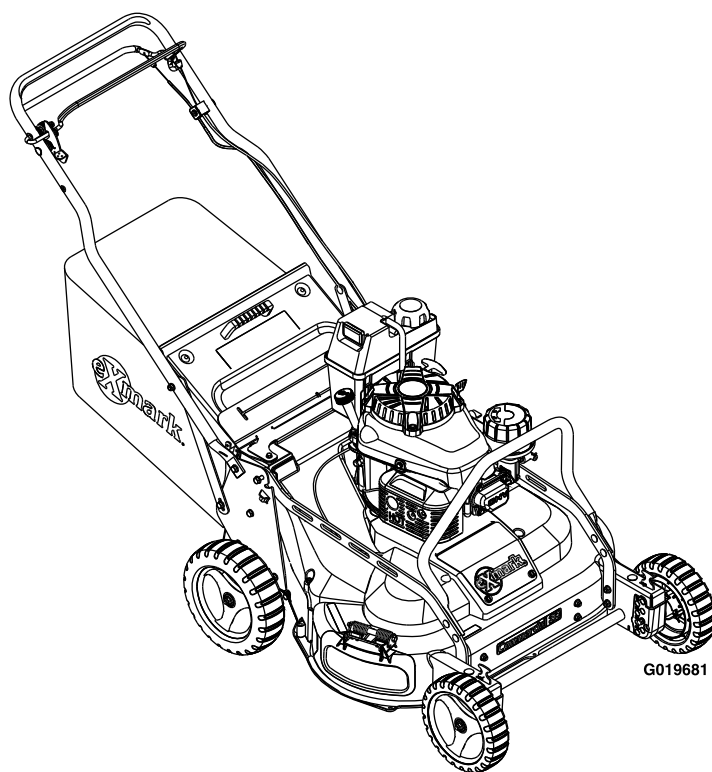

COMMERCIAL 30

Model No. ECS180CKA30000—Serial No. 31600000 and Up

Picture below may not reflect actual product.



G019681

Parts Manual

Part No. 4502-556 Rev. C

Ordering Replacement Parts

To order replacement parts, please supply the part number, the quantity, and the description of each part desired.

Understanding Reference Numbers

Each identified part in an illustration has a reference number. The reference number for a part also appears in the parts list, along with other information about the part.

This catalog uses two special reference number formats, one to indicate parts in a service assembly and another to indicate the quantity of a given part in an illustration.

Service Assembly Reference Numbers

Parts in service assemblies have reference numbers in the form a:b. The a represents the reference number of the entire service assembly and the b represents a sequential number unique to each part within the service assembly.

For example, a wheel assembly might be identified by reference number 6, the tire by 6:1, the valve by 6:2, and the wheel by 6:3. When you order the assembly identified by reference number 6, you receive all parts identified by reference numbers 6:1, 6:2, and 6:3. However, you may also order any part individually. Reference numbers of this type appear in illustration and in parts lists.

Reference Numbers Indicating Quantity

In an illustration, if a reference number indicates more than one part, the reference number has the form nX y. The n represents the quantity of the part, the X is the multiplication symbol, and the y represents the reference number.

For example, in an illustration, the reference number 2X 37 means that two of the parts identified by reference number 37 are indicated.

List of Abbreviations

AR: as required	HLH: hex lag head	PTH: phillips truss head
ASM: assembly	HOC: height-of-cut	PTO: power-take-off
BBC: blade brake control	HP: high pressure	RH: right hand
BHTF: button head thread forming	HSBH: hex socket button head	ROPS: roll-over protection system
CARR: carriage	HSFH: hex socket flat head	RRB: rear roller brush
CCW: counter clockwise	HSH: hex socket head	SFH: slotted fillister head
CW: clockwise	HWH: hex washer head	SHH: slotted hex head
DEG: degrees	HWHTF: hex washer head thread forming	SHWH: slotted hex washer head
DPA: Dual Point Adjustment	HYD: hydraulic	SPH: slotted pan head
ECM: electronic control module	LH: left hand	SQH: square head
EXT: external	LP: low pressure	SRH: slotted round head
FH: flat head	LPG: Liquefied Petroleum Gas	STD: standard
GA: gauge	NI: nylon insert	TAP: self tapping
HD: heavy-duty	NPTF: national pipe thread fine	TTH: torx truss head
HF: hex flange	PFH: phillips flat head	
HH: hex head	PPH: phillips pan head	
HHF: hex head flange	PPHTF: phillips pan head thread forming	
HHFTF: hex head flange thread forming	PRH: phillips round head	
HJ: hex jam		

Touch Up Paint

Exmark black touch up spray paint – gloss black.

Exmark red touch up paint (spray paint – P/N 1-850337 - .6 oz liquid bottle – P/N 103-9140).



If your Exmark dealer does not have the Exmark part in stock, Exmark will get the parts to the dealer the next business day or the part will be FREE Guaranteed!! (Some restrictions apply. See your participating Exmark Dealer for details.)

Contents

Deck, Frame, and Chute Assembly	4
Deck W/Decals Assembly	6
Spindle and Blade Assembly	8
Side Discharge Chute Assembly	10
Bag Assembly	12
Engine and Fuel Tank Assembly	14
Front Bumper and Wheel Assembly	16
Deck and Wheel Assembly	18
Handle Assembly	20

Deck, Frame, and Chute Assembly

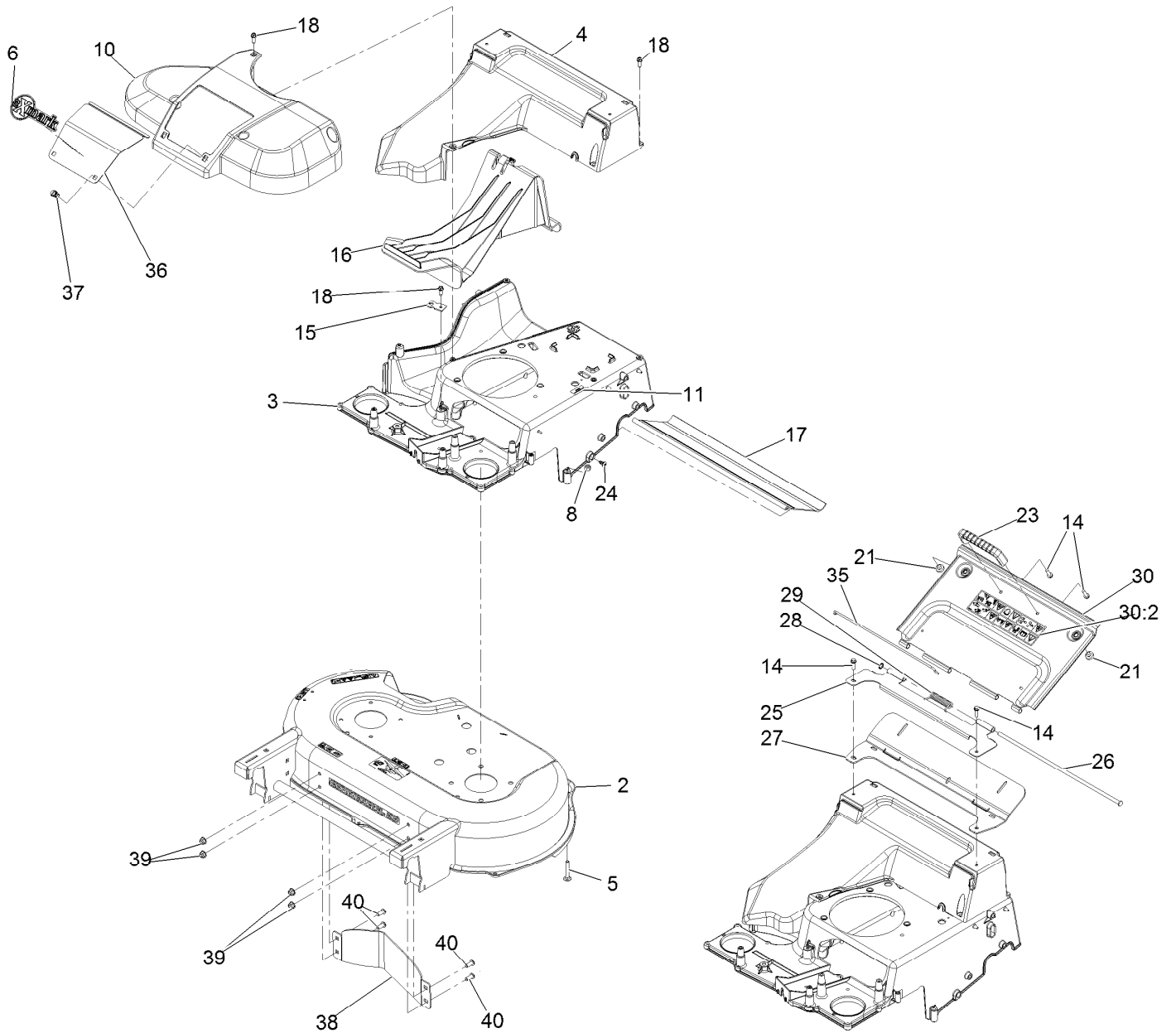

Deck, Frame, and Chute Assembly (continued)

<i>Ref.</i>	<i>Part Number</i>	<i>Qty.</i>	<i>Description</i>	<i>Ref.</i>	<i>Part Number</i>	<i>Qty.</i>	<i>Description</i>
2	126-7582	1	Deck-30, W/Decals	26	116-6933	1	Pin-Hinge
3	131-9659-01	1	Frame	27	116-6229	1	Seal-Door
4	120-3336	1	Chute	28	32151-72	1	Ring-Retaining
5	127-6841	2	Screw-CARR	29	116-7573	1	Spring-Torsion, Cover
6	126-6575	1	Decal-Exmark Logo	30	116-8355	1	Rear Door ASM
8	3296-29	2	Nut-Nyloc 5/16-18	30:2	116-7583	1	Decal-Warning
10	121-5810	1	Cover-Belt	35	116-6966	1	Clip-Seal
11	126-4345	1	Decal-Patent Ttco.Com	36	121-5793-03	1	Door-Access
14	46-8091	4	Screw-HWH 1/4-10 X .82 Plastite	37	121-5840	2	Fastener
15	107-7497	1	Bracket-Cable, Traction	38	130-2352-01	1	Baffle-Control
16	120-5225	1	Plug-Mulch	39	104-8300	4	Nut-Nyloc 5/16-18 Flg
17	121-5841	1	Shield-Trailing	40	3274-55	4	Screw-Button Head 5/16-18 X 3/4
18	49-2040	9	Screw-HWH 1/4-20 X 3/4 Tf	99	125-5072	1	Frame Plate Kit (Service)●
21	1-513658	2	Bumper	99:1	125-2542	1	Plate Frame ASM●
23	65-5100	1	Handle-Door	99:2	3229-3	3	Bolt-Carriage 1/4-20 X 1 1/4 ●
24	117-1092	2	Screw-PTH	99:3	3296-42	3	Nut-Nyloc 1/4-20●
25	116-6351-03	1	Bracket-Hinge				

● Not illustrated

Deck W/Decals Assembly

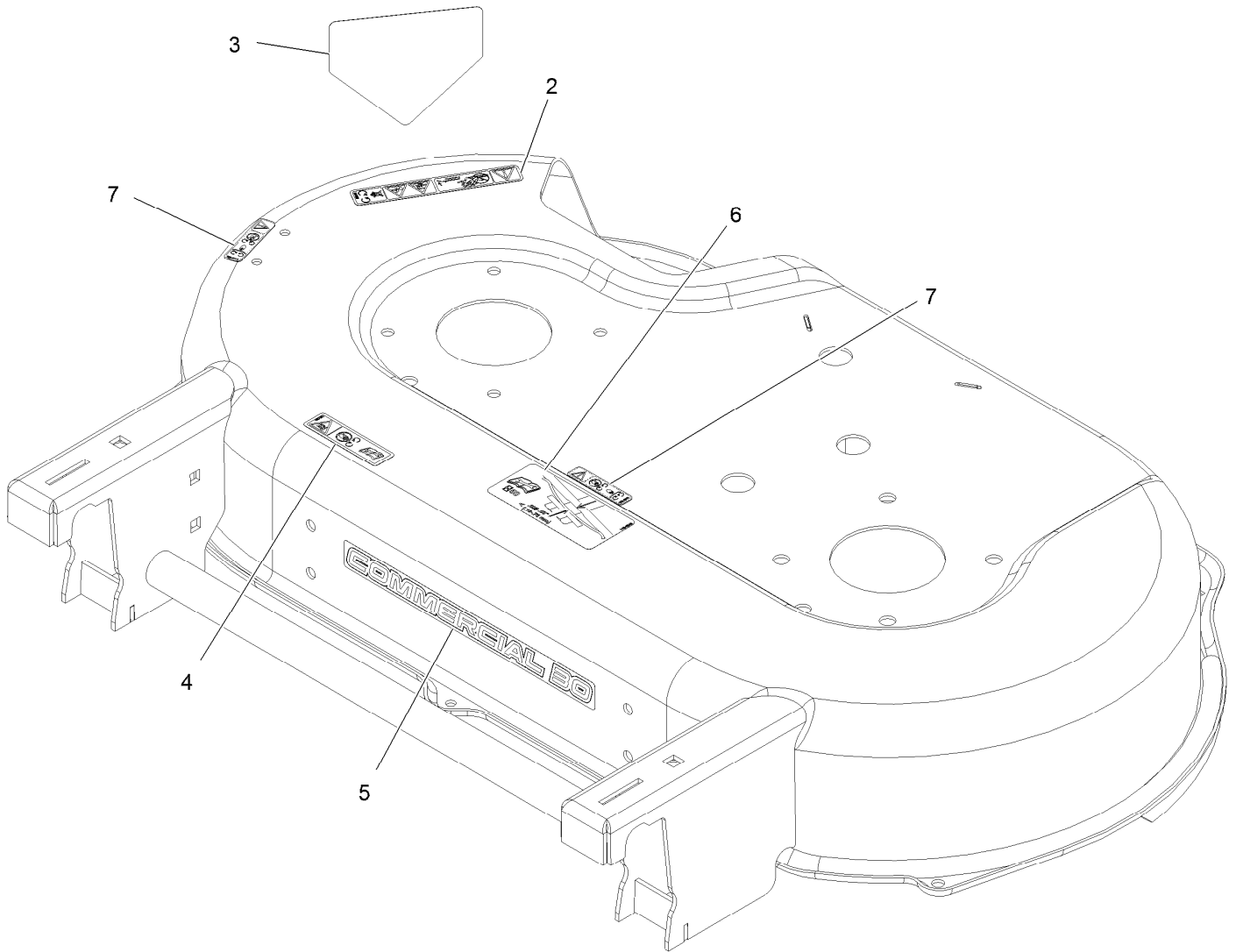

Deck W/Decals Assembly (continued)

<i>Ref.</i>	<i>Part Number</i>	<i>Qty.</i>	<i>Description</i>	<i>Ref.</i>	<i>Part Number</i>	<i>Qty.</i>	<i>Description</i>
2	93-7009	1	Decal-Danger	5	126-6889	1	Decal-Commercial 30
3	94-8072	1	Decal-Danger	6	116-8528	1	Decal
4	116-7581	1	Decal-Warning	7	120-9570	2	Decal-Warning

Spindle and Blade Assembly

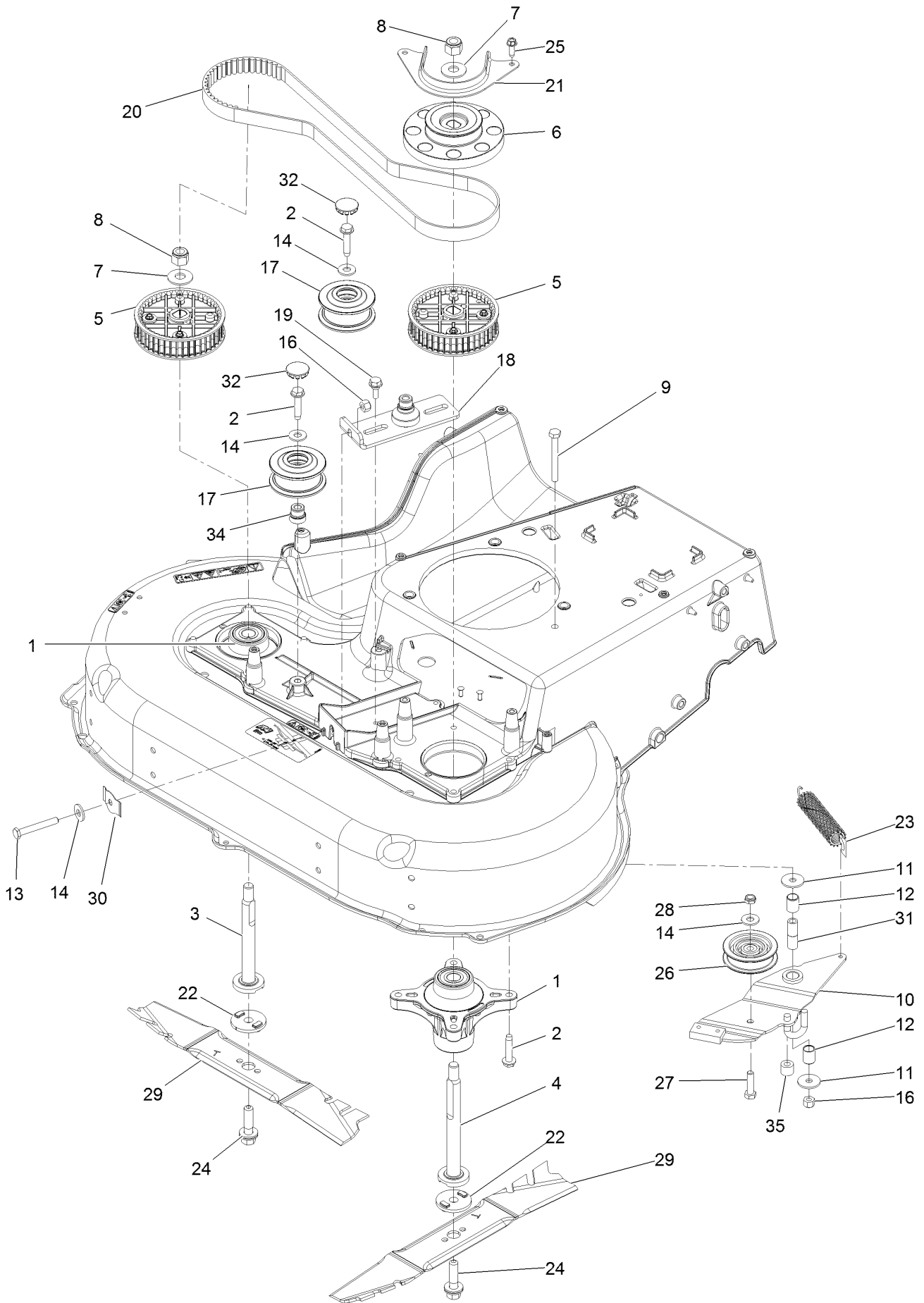

Spindle and Blade Assembly (continued)

<i>Ref.</i>	<i>Part Number</i>	<i>Qty.</i>	<i>Description</i>	<i>Ref.</i>	<i>Part Number</i>	<i>Qty.</i>	<i>Description</i>
1	120-6234	2	Spindle ASM	19	120-7024	2	Screw-HH Flg 1/4-20 X 3/4 Tf
2	32144-57	10	Screw-HWH 5/16-18 X 1 1/2 Tf	20	120-3335	1	Belt-Synchronous
3	120-5234	1	Shaft-Spindle	21	120-5245-03	1	Guide-Belt, Spindle
4	120-5235	1	Shaft-Spindle	22	120-5236	2	Adapter-Blade
5	121-9100	2	Sprocket	23	121-5808	1	Spring-Extension, Brake
6	130-6664	1	Pulley-Brake, Spindle	24	125-2466	2	Bolt-Blade
7	109-9505	2	Washer, Spring Disc 1/2	25	49-2040	2	Screw-HWH 1/4-20 X 3/4 Tf
8	3296-19	2	Nut-Nyloc 1/2-20	26	120-7082	1	Pulley-Idler
9	322-13	1	Screw-HH 5/16-18 X 2 3/4	27	322-6	1	Screw-HH 5/16-18 X 1 1/4
10	133-2610	1	Brake Arm ASM	28	3296-47	1	Nut-Nyloc 5/16-18 Thin
11	5-4460	2	Washer-Pivot	29	116-6358-03	2	Blade-Rotary
12	131-0819	2	Bushing-Sleeve	30	121-2336	1	Spring-Flat
13	9114524	1	Bolt-HH 5/16-18 X 2 1/4 Tap	31	131-0823	1	Spacer-Brake
14	3256-3	4	Washer-5/16 Std	32	126-7151	2	Plug Button, Crs 1.0 Dia .093-.125
16	3296-29	2	Nut-Nyloc 5/16-18	34	131-4504	1	Adapter-Bore
17	126-5880	2	Pulley, Flat Idler Flanged	35	133-1964	1	Hose-Coolant
18	126-6453	1	Bracket - Idler				

Side Discharge Chute Assembly

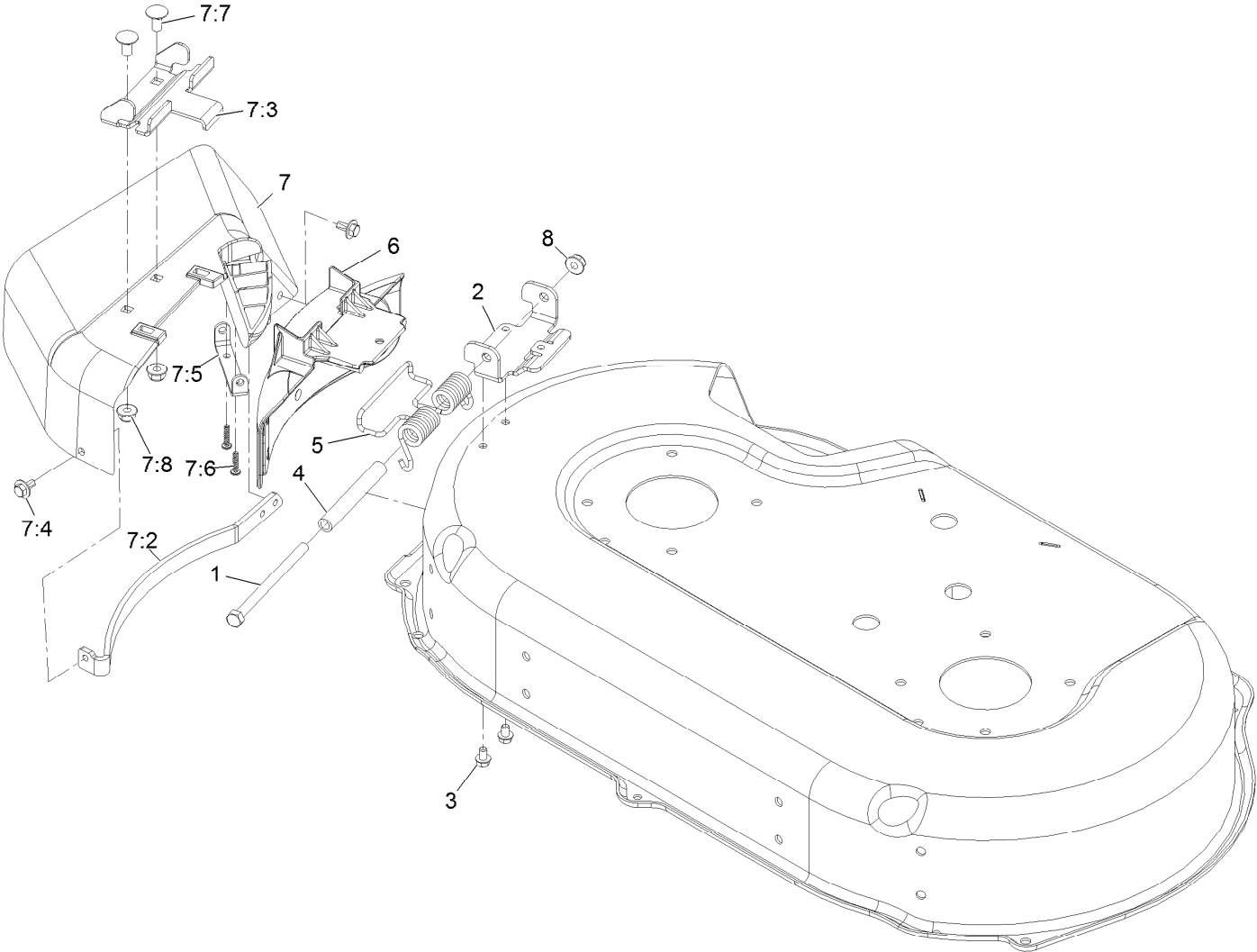

Side Discharge Chute Assembly (continued)

<i>Ref.</i>	<i>Part Number</i>	<i>Qty.</i>	<i>Description</i>	<i>Ref.</i>	<i>Part Number</i>	<i>Qty.</i>	<i>Description</i>
1	322-38	1	Screw-HH 5/16-18 X 4 1/2	7:2	116-9752-03	1	Guard-Chute
2	121-9195	1	Hinge	7:3	121-9196	1	Bracket-Chute
3	99-8445	2	Screw-HWH 1/4-20 X 3/8 Taptite	7:4	46-8560	2	Screw-HHF 1/4-20 X 1/2
4	125-2478	1	Spacer	7:5	112-6416	1	Bracket-Cover
5	121-9193	1	Spring-Torsion	7:6	94-4496	2	Screw-PPH
6	125-5093-01	1	Cover-Discharge	7:7	3230-18	2	Bolt-Carriage 5/16-18 X 5/8
7	116-9754	1	Side Discharge Chute ASM	7:8	104-8300	2	Nut-Nyloc 5/16-18 Flg
				8	104-8300	1	Nut-Nyloc 5/16-18 Flg

Bag Assembly

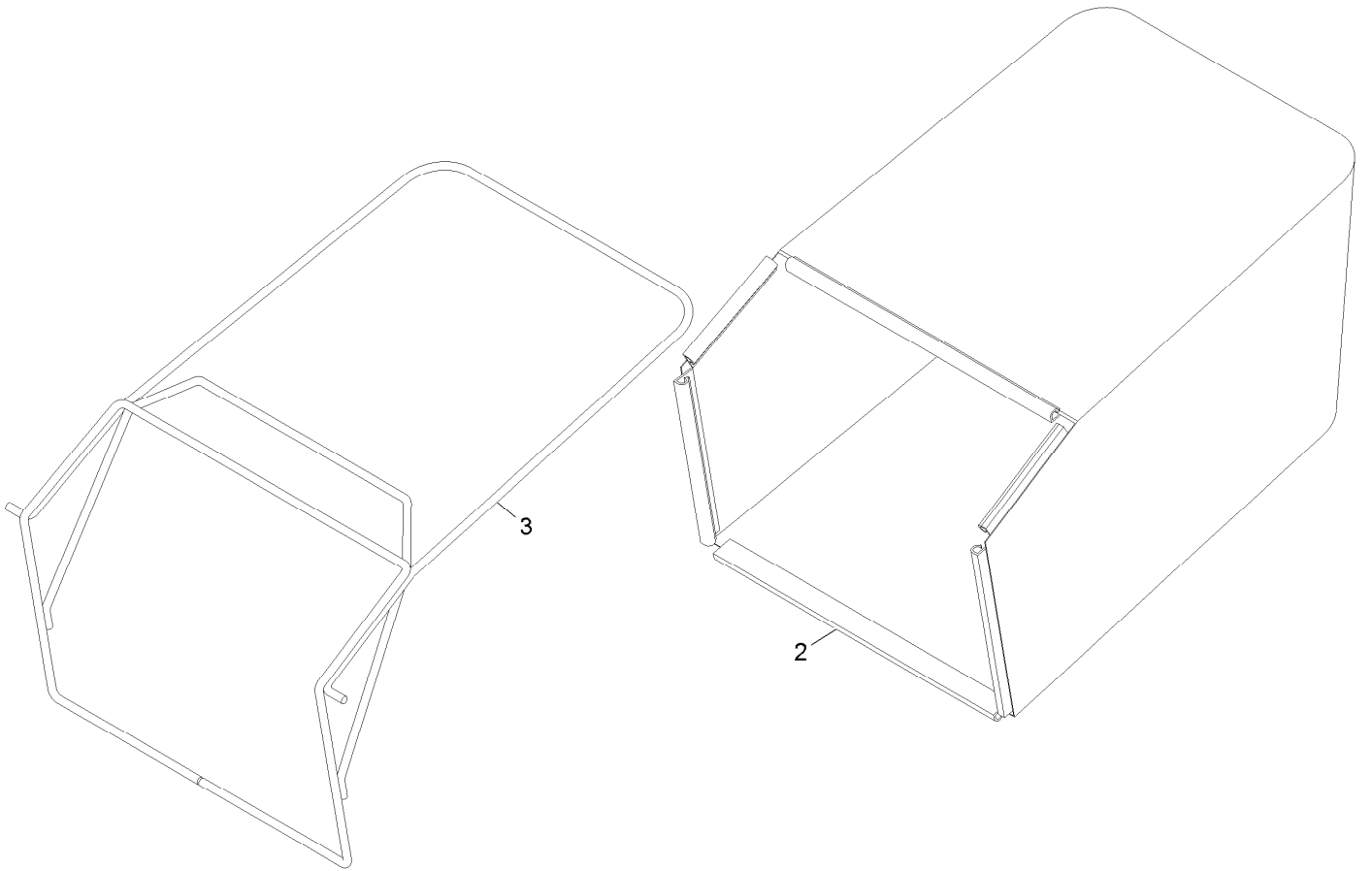

Bag Assembly (continued)

<i>Ref.</i>	<i>Part Number</i>	<i>Qty.</i>	<i>Description</i>
2	116-6350	1	Bag-Grass
3	116-5596-03	1	Frame-Bag

Engine and Fuel Tank Assembly

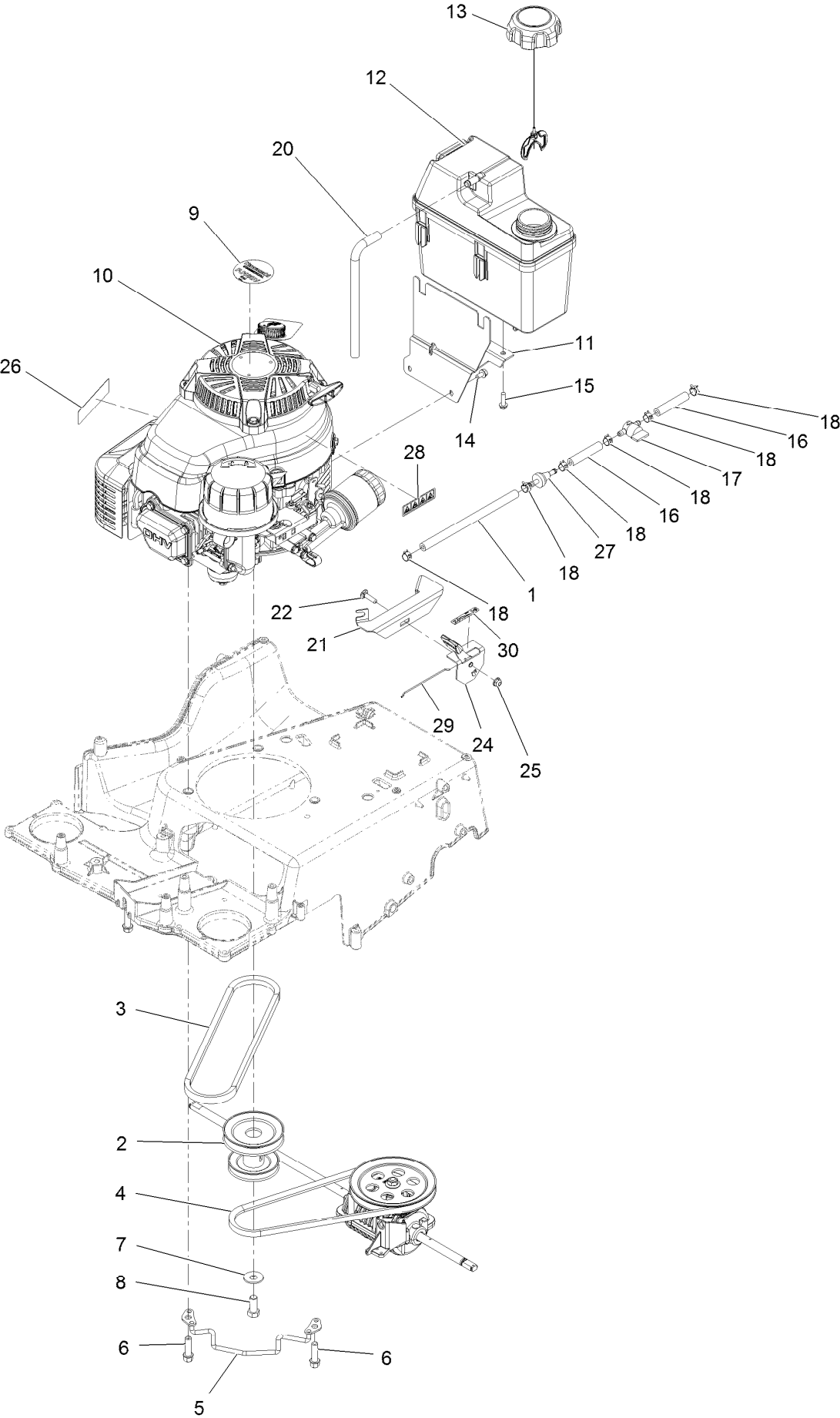

Engine and Fuel Tank Assembly (continued)

<i>Ref.</i>	<i>Part Number</i>	<i>Qty.</i>	<i>Description</i>	<i>Ref.</i>	<i>Part Number</i>	<i>Qty.</i>	<i>Description</i>
1	119-1892	1	Hose-Fuel	15	46-8091	2	Screw-HWH 1/4-10 X .82 Plastite
2	116-7013	1	Pulley-Engine	16	109-0304	2	Hose-Fuel Line 2 1/2"
3	121-5765	1	V-Belt	17	1-603770	1	Valve-Fuel
4	116-7116	1	Belt	18	2412-98	6	Clamp-Hose
5	120-7077	1	Guide-Belt	20	115-0962	1	Hose-Vent, Canister
6	95-1727	3	Screw-HWH 3/8-16 X 1 1/4 Taptite	21	130-6440-03	1	Bracket-Mount, Throttle
7	3290-465	1	Washer-Spring Disc	22	3229-30	1	Bolt-Carriage 1/4-20 X 1
8	3212-4	1	Screw-HH 7/16-20 X 1	24	130-9655	1	Control-Throttle
9	109-6528	1	Decal-Recoil	25	104-7201	1	Nut-Nyloc 1/4-20 Flg
10		1	Engine-Kawasaki Fj180V ●■	26	117-2718	1	Decal-Arrester, Spark
11	115-0954-03	1	Mount-Tank	27	71-9280	1	Filter-Fuel
12	114-0280	1	Tank-Fuel	28	116-9313	1	Decal-Warning, Engine
13	115-7788	1	Cap-Fuel	29	130-9654	1	Wire-Control
14	116-8929	3	Screw-HWH	30	130-9656	1	Decal-Throttle, Choke

● Not serviced separately

■ Obtain parts from www.kawpowerepc.com

Front Bumper and Wheel Assembly

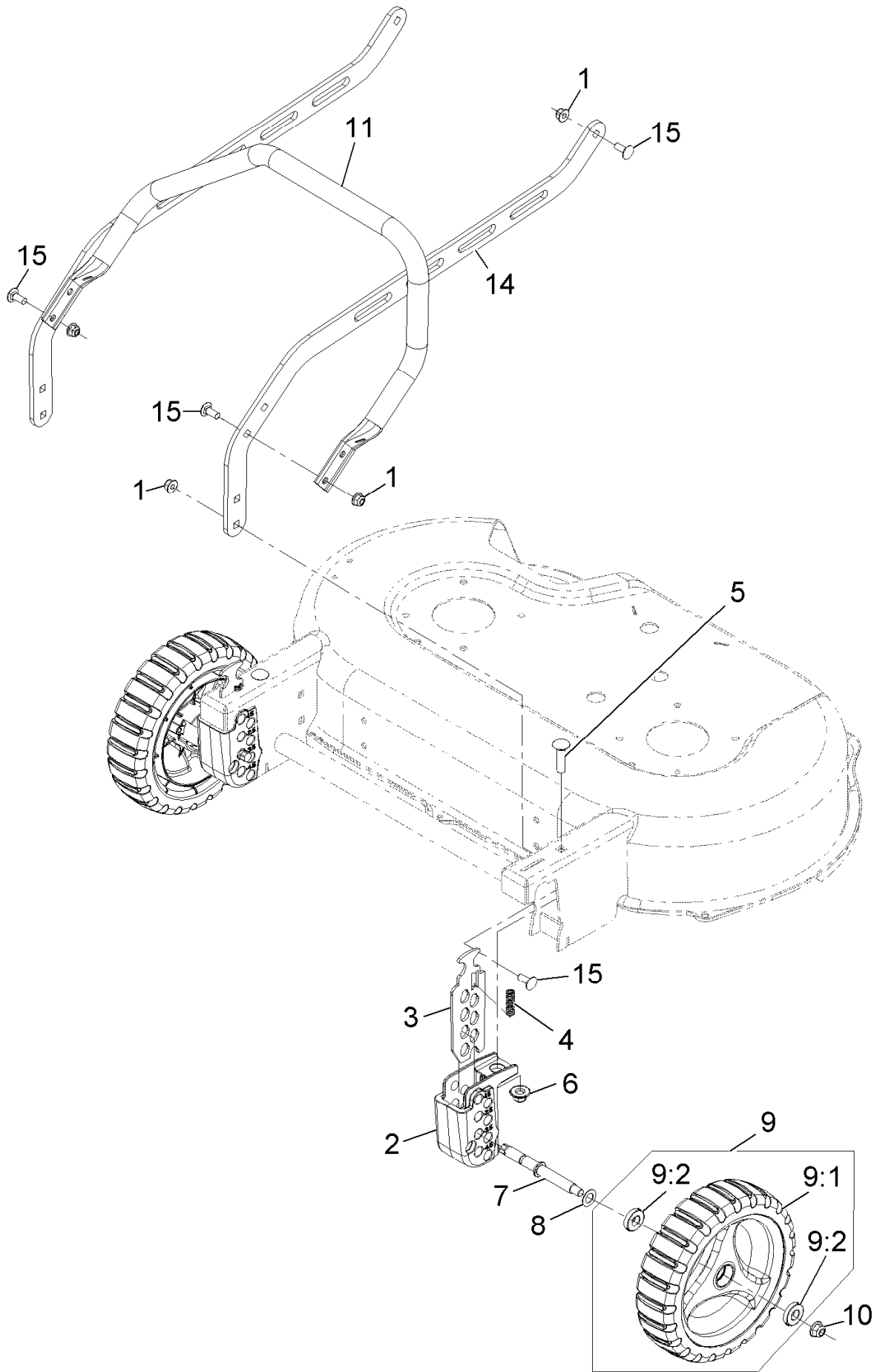

Front Bumper and Wheel Assembly (continued)

<i>Ref.</i>	<i>Part Number</i>	<i>Qty.</i>	<i>Description</i>	<i>Ref.</i>	<i>Part Number</i>	<i>Qty.</i>	<i>Description</i>
1	104-8300	10	Nut-Nyloc 5/16-18 Flg	9	109-8016	2	Wheel And Tire ASM
2	116-6357	2	Block-Front Quadrant	9:1	109-8033	1	9-Inch Wheel ASM
3	109-9292	2	Plate, Front Height	9:2	109-8020	2	Bearing-Ball
4	109-7258	2	Spring-Compression	10	104-8301	2	Nut-Nyloc 3/8-16 Flg
5	3231-26	2	Bolt-Carriage 3/8-16 X 1 1/2	11	116-7675-03	1	Guard-Engine
6	109-6658	2	Nut-Nyloc 3/8-16 Flg	14	116-7661-03	2	Brace-RH
7	116-0994	2	Axle-Wheel	15	3230-23	10	Bolt-Carriage 5/16-18 X 3/4 Short Neck
8	36-4780	2	Washer				

Deck and Wheel Assembly

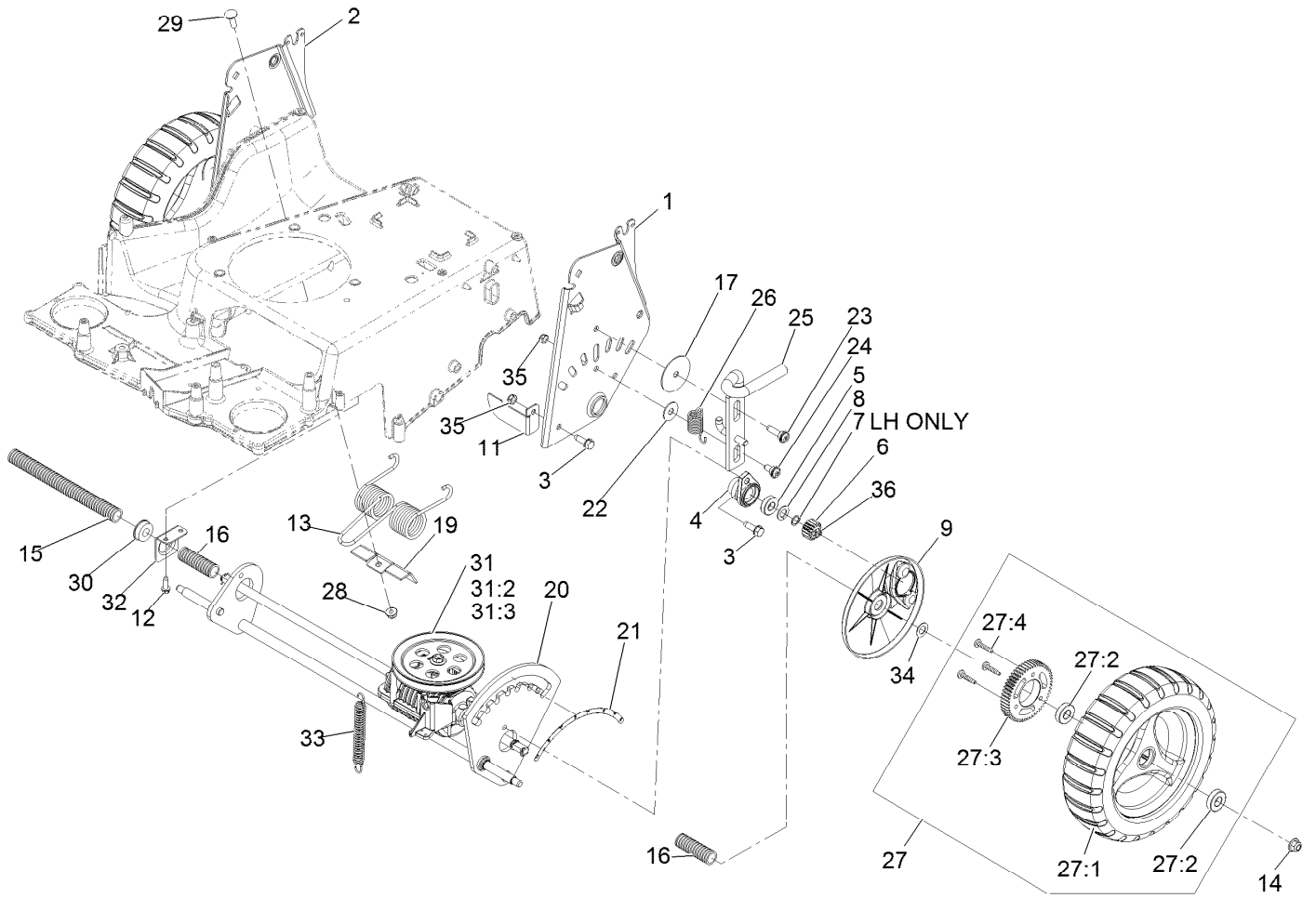

Deck and Wheel Assembly (continued)

<i>Ref.</i>	<i>Part Number</i>	<i>Qty.</i>	<i>Description</i>	<i>Ref.</i>	<i>Part Number</i>	<i>Qty.</i>	<i>Description</i>
1	121-2394-03	1	LH HOC Plate ASM	24	120-9471	1	Screw-Shoulder Bh 5/16-18 X 1/2 Tf Torx
2	121-2395-03	1	RH HOC Plate ASM	25	120-7090	1	Lock-Height, Adjust
3	701243	7	Screw-HWH 5/16-18 X 1 Tf	26	120-9452	1	Spring-Extension
4	131-5364	2	Retainer-Bearing	27	116-5291	2	10-Inch Rear Wheel
5	109-8020	2	Bearing-Ball	27:1	116-5292	1	ASM-Wheel 10"
6	131-5399	2	Gear-Pinion, 15T	27:2	109-8020	2	Bearing-Ball
7	32151-61	1	Ring-Retaining	27:3	109-7264	1	Gear
8	110-7191	2	Washer-Thrust	27:4	27-6260	3	Screw-Drive
9	116-6352	2	Cover-Gear	28	104-8300	1	Nut-Nyloc 5/16-18 Flg
11	121-5821	1	Bracket-Stop	29	3230-2	1	Bolt-Carriage 5/16-18 X 1
12	49-2040	2	Screw-HWH 1/4-20 X 3/4 Tf	30	104-8699	1	Bearing-Ball
13	121-2368	1	Spring-Torsion	31	131-9667	1	Transmission Kit
14	104-8301	2	Nut-Nyloc 3/8-16 Flg	31:2	130-2369	2	Pin-Snap
15	121-5799	1	Conduit-Convoluted	31:3	32151-61	1	Ring-Retaining
16	121-5800	2	Conduit-Convoluted	32	120-7008	1	Mount-Bearing
17	125-2540	1	Washer-Plain	33	120-7027	1	Spring-Extension
19	121-2397	1	Bracket	34	36-4780	2	Washer
20	131-4516	1	Axle-Rear	35	3296-47	2	Nut-Nyloc 5/16-18 Thin
21	116-7127	1	Decal-HOC, Rear	36	130-2369	2	Pin-Snap
22	52-2860	1	Washer				
23	119-2267	1	Screw-Button Head 5/16-18 X 1 Tf				

Handle Assembly

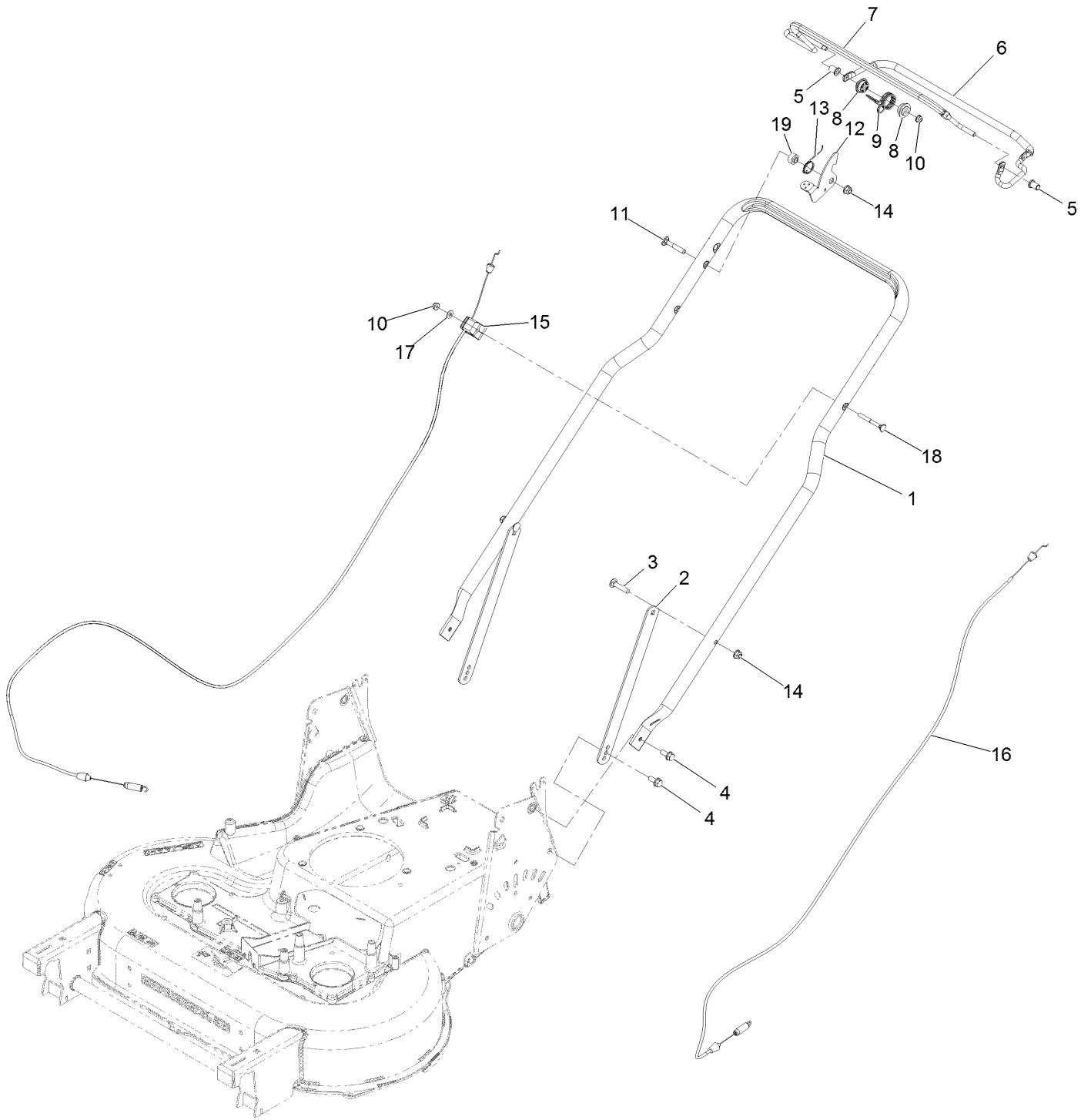

Handle Assembly (continued)

<i>Ref.</i>	<i>Part Number</i>	<i>Qty.</i>	<i>Description</i>	<i>Ref.</i>	<i>Part Number</i>	<i>Qty.</i>	<i>Description</i>
1	120-7086-03	1	Handle	11	112-8876	1	Bolt-Carriage 5/16-18 X 2
2	116-8208-03	2	Support-Handle	12	116-2998	1	Lever-BBC
3	3230-4	2	Bolt-Carriage 5/16-18 X 1 1/2	13	109-9318	1	Spring-Lever, BBC
4	116-7230	4	Screw-HHF	14	104-8300	3	Nut-Nyloc 5/16-18 Flg
5	116-1478	2	Bushing-Handlebar	15	121-2310	1	Cable-Brake, BBC
6	116-7907	1	Bail-Drive Coated	16	126-1664	1	Cable-Traction
7	109-8442	1	Bail	17	3256-1	1	Washer-Flat
8	109-8457	2	Bushing-Spring, Pivot	18	92-2270	1	Screw-Handle
9	116-5594	1	Spring-Return, BBC	19	116-2690	1	Bushing-Stepped
10	104-7201	2	Nut-Nyloc 1/4-20 Flg	99	614249	3	Tie-Cable ●

● Not illustrated

Notes:



MAXIMIZE THE PERFORMANCE OF YOUR EXMARK MACHINE.



EXMARK® PREMIUM ENGINE OIL

Exmark now offers a family of engine oil viscosities to perform well in any environment. Each viscosity has the same synthetic formulation to give you what you need in punishing conditions. We designed each grade to the highest quality, making it ideal even for diesel applications. Coupled with Exmark Premium Fuel Treatment, we have the performance products to make your machine hum.

EXMARK PREMIUM ENGINE OIL SAE 30/10W-30

- Meets zero shear requirements of a straight grade SAE 30 as well as the cold temp properties of a 10W-30.
- Most versatile oil in the industry.
- Superior corrosion protection over conventional oil - even in corrosive, humid environments.

EXMARK PREMIUM ENGINE OIL SAE 20W-50

- Perfect for your big block engine, or any application in severe service.
- Same full synthetic formulation as all other Exmark Premium viscosities.
- Also effective for use in severe service small block engines.

EXMARK PREMIUM ENGINE OIL SAE 10W-50

- Full synthetic formulation gives you peak performance. Don't settle for less.
- Wide span multi-grade combines easy starting in cold weather with maximum protection in high temperature operation.
- Reduce friction & wear over standard mineral formulations.

EXMARK PREMIUM ENGINE OIL SAE 0W-40

- The perfect choice for when the weather turns cold or unpredictable, and your Exmark UTV has to perform.
- Commercial quality for severe service.
- Advanced additive package helps prevent corrosion from long-term storage.

EXMARK PREMIUM ENGINE OIL UTV FORMULATION

- 4-cycle high-temp formulation.
- Heavier viscosity, full synthetic, perfect for your UTV.

EXMARK PREMIUM UTV EXTREME CONDITIONS GEAR OIL

- SAE 80W-90, designed to keep your UTV performing at its peak.
- Shear stable, hypoid gear lube.
- Includes a premium additive system to combat wear, oxidation, rust & corrosion.

Available from your local Exmark dealer. Find your closest dealer at exmark.com

EXMARK ACCESSORIES AND OPTIONS*

MID-MOUNT RIDING ACCESSORIES AND OPTIONS

CUSTOM RIDE SEAT SUSPENSION SYSTEM	OPERATOR CONTROLLED DISCHARGE
FULL SUSPENSION SEAT	SUN SHADE
DECK LIFT ASSIST KIT	TRASH CONTAINER
HITCH KIT	TURF STRIPER
LIGHT KIT	ULTRA VAC COLLECTION SYSTEM
12V POWER PORT	ULTRA VAC QUICK DISPOSAL SYSTEM
MICRO-MULCH SYSTEM	

OUT-FRONT RIDING ACCESSORIES AND OPTIONS

CUSTOM RIDE SEAT SUSPENSION SYSTEM	SNOW BLADE
DUAL-TAIL WHEEL	SNOWBLOWER
FLOOR PAN EXTENDER	SUN SHADE
HITCH KIT	TRASH CONTAINER
LIGHT KIT	ULTRA VAC COLLECTION SYSTEM
MICRO-MULCH SYSTEM	ULTRA VAC QUICK DISPOSAL SYSTEM
ROLL OVER PROTECTION SYSTEM (ROPS)	WEATHER CAB

WALK-BEHIND ACCESSORIES AND OPTIONS

GRASS CATCHER	TURF STRIPER
MICRO-MULCH SYSTEM	STANDON

*Some accessories and options not available for some models.

Place Model No. and Serial No.
Label Here (Included in the Literature
Pack) or Fill in Below

Model No. _____

Serial No. _____

Date Purchased _____

Engine Model No. and Spec. No. _____

Engine Serial No. (E/No) _____

© 2016 Exmark Mfg. Co., Inc.
Industrial Park Box 808
Beatrice, NE 68310
All Rights Reserved

Part No. 4502-556 Rev. C
(402) 223-6300
Fax (402) 223-5489
Printed in the USA.

