

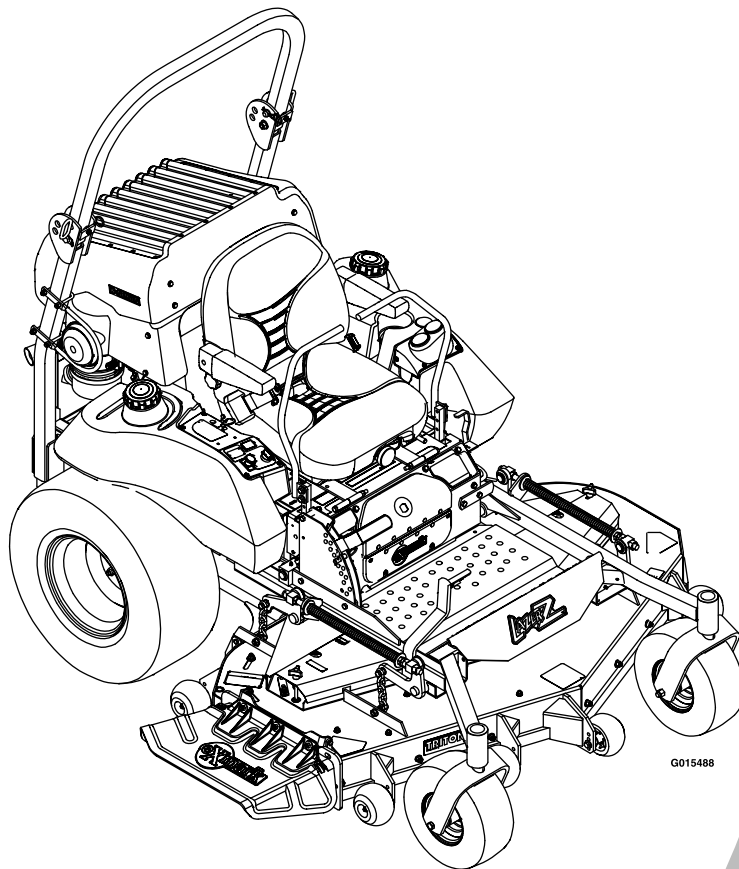

LAZER Z[®] DS-SERIES

Model No. LZS902DKU725A1—Serial No. 31500000 and Up

Picture below may not reflect actual product.



G015488

Parts Manual

Part No. 4502-107 Rev. A

Ordering Replacement Parts

To order replacement parts, please supply the part number, the quantity, and the description of each part desired.

Understanding Reference Numbers

Each identified part in an illustration has a reference number. The reference number for a part also appears in the parts list, along with other information about the part.

This catalog uses two special reference number formats, one to indicate parts in a service assembly and another to indicate the quantity of a given part in an illustration.

Service Assembly Reference Numbers

Parts in service assemblies have reference numbers in the form a:b. The a represents the reference number of the entire service assembly and the b represents a sequential number unique to each part within the service assembly.

For example, a wheel assembly might be identified by reference number 6, the tire by 6:1, the valve by 6:2, and the wheel by 6:3. When you order the assembly identified by reference number 6, you receive all parts identified by reference numbers 6:1, 6:2, and 6:3. However, you may also order any part individually. Reference numbers of this type appear in illustration and in parts lists.

Reference Numbers Indicating Quantity

In an illustration, if a reference number indicates more than one part, the reference number has the form nX y. The n represents the quantity of the part, the X is the multiplication symbol, and the y represents the reference number.

For example, in an illustration, the reference number 2X 37 means that two of the parts identified by reference number 37 are indicated.

List of Abbreviations

AR: as required	HLH: hex lag head	PTH: phillips truss head
ASM: assembly	HOC: height-of-cut	PTO: power-take-off
BBC: blade brake control	HP: high pressure	RH: right hand
BHTF: button head thread forming	HSBH: hex socket button head	ROPS: roll-over protection system
CARR: carriage	HSFH: hex socket flat head	RRB: rear roller brush
CCW: counter clockwise	HSH: hex socket head	SFH: slotted fillister head
CW: clockwise	HWH: hex washer head	SHH: slotted hex head
DEG: degrees	HWHTF: hex washer head thread forming	SHWH: slotted hex washer head
DPA: Dual Point Adjustment	HYD: hydraulic	SPH: slotted pan head
ECM: electronic control module	LH: left hand	SQH: square head
EXT: external	LP: low pressure	SRH: slotted round head
FH: flat head	LPG: Liquefied Petroleum Gas	STD: standard
GA: gauge	NI: nylon insert	TAP: self tapping
HD: heavy-duty	NPTF: national pipe thread fine	TTH: torx truss head
HF: hex flange	PFH: phillips flat head	
HH: hex head	PPH: phillips pan head	
HHF: hex head flange	PPHTF: phillips pan head thread forming	
HHFTF: hex head flange thread forming	PRH: phillips round head	
HJ: hex jam		

Touch Up Paint

Exmark black touch up spray paint – gloss black.

Exmark red touch up paint (spray paint – P/N 1-850337 - .6 oz liquid bottle – P/N 103-9140).



If your Exmark dealer does not have the Exmark part in stock, Exmark will get the parts to the dealer the next business day or the part will be FREE Guaranteed!! (Some restrictions apply. See your participating Exmark Dealer for details.)

Contents

Complete Deck Assembly	4
Deck Assembly No. 116-9126	6
Deck W/Decals Assembly No. 109-2105	8
Idler Arm W/Bearings Kit No. 109-2095	10
Cutter Housing Assembly No. 103-9539	12
Front Frame Assembly	14
Front Frame Assembly No. 116-9499	16
Front Frame Assembly (cont)	18
Wheel and Tire Assembly No. 109-9127	20
Front Frame Spring Assembly No. 109-4995	22
Main Frame Assembly	24
Neutral Return Assembly No. 109-3903	26
Engine Deck W/Decals Assembly No. 109-3984	28
Motion Control Assembly	30
LH Motion Control Assembly No. 109-3979	32
RH Motion Control Assembly No. 109-3978	34
Tracking Rod Assembly No. 103-3062	36
RH Hydro Connecting Link Assembly No. 103-5190	38
Park Brake Assembly	40
Seat Assembly	42
Seat W/Tracks Assembly No. 116-8912	44
Seat Frame Single Latch Assembly	46
Fuel Assembly	48
Fuel Valve Hose Assembly	50
Engine Assembly	52
Cooling Assembly	54
Hood Assembly	56
Latch Plate Assembly No. 109-8427	58
Mule Drive Assembly	60
Tightener Arm W/Pulley Assembly No. 116-9286	62
Hydraulic Assembly	64
Electrical Assembly	66

Complete Deck Assembly

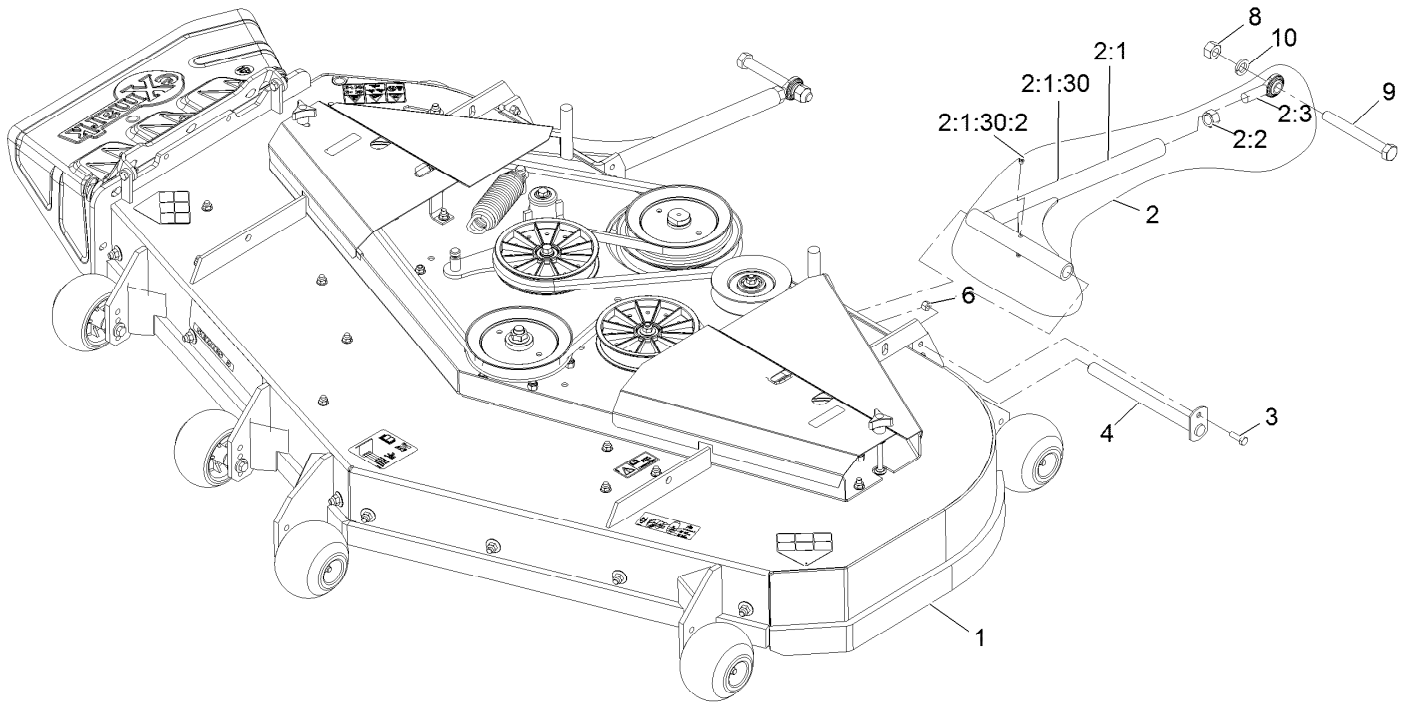

Complete Deck Assembly (continued)

<i>Ref.</i>	<i>Part Number</i>	<i>Qty.</i>	<i>Description</i>	<i>Ref.</i>	<i>Part Number</i>	<i>Qty.</i>	<i>Description</i>
1	116-9149	1	ASM-Deck Complete 725	3	322-5	2	Screw-HH 5/16-18 X 1
2	103-8544	2	Asm, Strut 66" And 72"	4	1-632199-01	2	Pin-Strut
2:1	109-1183	1	Wld, Deck Strut-Std 72	6	3296-29	2	Nut-Nyloc 5/16-18
2:1:30		1	Tube And Zerk ASM ●	8	3217-11	2	Nut-Hex 5/8-11
2:1:30:2	109-1380	2	Fitting-Grease	9	327-28	2	Screw-HH 5/8-11 X 5 1/2
2:2	3219-6	1	Nut-Hex 5/8-18	10	3253-8	2	Washer-Lock 5/8
2:3	1-633029	1	Balljoint				

● Not serviced separately

Deck Assembly No. 116-9126

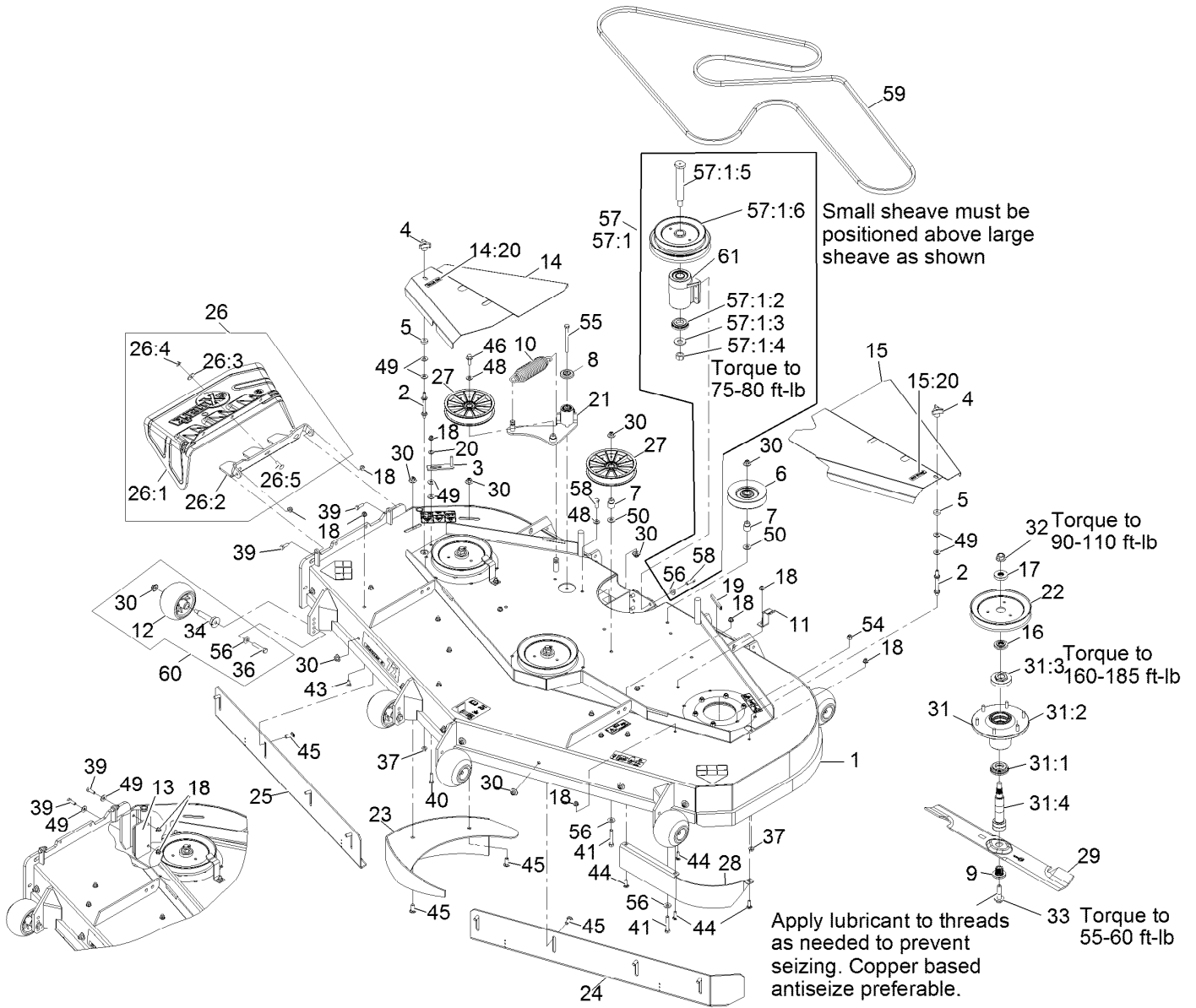

Deck Assembly No. 116-9126 (continued)

Ref.	Part Number	Qty.	Description	Ref.	Part Number	Qty.	Description
1	109-2105	1	Asm, Deck W/Decals 72"	29	103-9625	3	Blade, Medium Lift 72"
2	1-303537	2	Stud-Shield, Belt (Short)	29	103-9622	3	Blade, Low Lift 72"
3	1-322110	1	Guide-Belt	30	109-6658	20	Nut-Nyloc 3/8-16 Flg
4	1-323385	2	Knob-3 Prong	31	109-6917	3	ASM,Spindle Housing
5	1-323417	2	Washer-Belt Shield	31:1	103-9504	1	Guard, Bottom
6	1-603805	1	Pulley-Idler	31:2	103-9539	1	Asm, Cutter Housing
7	1-633456	2	Bushing, Idler	31:3	109-0916	1	Nut, Spindle 7/8-14
8	103-2916	1	Guard-Top	31:4	109-6881	1	Spindle,Double Spline ▲
9	103-3037	3	Bushing, Splined	32	109-7033	3	Nut-Flange 5/8-18 Centerlock
10	116-6317	1	Spring-Extension	33	109-9220	3	Screw-Sems 1/2-20 X 2.19
11	103-8103-01	2	Latch, Belt Shield	34	116-8131	6	Axle, Roller
12	103-8415	6	Roller-Anti-Scalp	36	116-9362	6	Screw-HH 3/8-16 X 3 3/4 Gr 8
13	103-9423-01	1	Deflector, Discharge 72"	37	32128-20	2	Nut-Whizlock 5/16-18
14	109-2135	1	Asm, Shield W/Decal 72" RH	39	322-5	4	Screw-HH 5/16-18 X 1
14:20	1-513742	1	Decal, No Step	40	322-6	1	Screw-HH 5/16-18 X 1 1/4
15	109-2134	1	Asm, Shield W/Decal 72" LH	41	323-11	2	Screw-HH 3/8-16 X 2 1/4
15:20	1-513742	1	Decal, No Step	43	3230-18	10	Bolt-Carriage 5/16-18 X 5/8
16	103-9522	3	Spacer, Splined Stepped	44	3230-22	5	Bolt-Carriage 5/16-18 X 1 Sp
17	103-9523	3	Spacer, Splined	45	3231-22	10	Bolt-Carriage 3/8-16 X 1
18	104-8300	20	Nut-Nyloc 5/16-18 Flg	46	3234-11	1	Screw-HH Flg 3/8-16 X 1
19	105-7699	4	Strip-Seal	48	3256-24	2	Washer-3/8 Sae
20	1-303334	1	Washer-Spring Disc 5/16	49	3256-3	8	Washer-5/16 Std
21	109-2095	1	Kit, Idler Arm W/Bearings	50	3256-4	2	Washer-3/8 Std
22	109-0929	3	Sheave-Blade Drive	54	3296-39	18	Nut-Nyloc 3/8-16
23	109-1039-01	1	Wld, Dogleg 72"	55	98-5961	1	Screw-HH 3/8-16 X 4 Gr8
24	109-1044-01	1	Wld, Baffle Front Adj LH 72"	56	98-5975	12	Washer-Spring Disc 3/8
25	109-1047-01	1	Wld, Baffle Front Adj RH 72"	57	103-3249	1	Jackshaft Assy
26	109-2099	1	Asm, Discharge Chute	57:1		1	ASM, Jackshaft 60 & 72 - 3750 ●
26:1	109-2739	1	Chute, Discharge Lz	57:1:2	103-2535	1	Spacer-Guard Bottom
26:2	109-0498-01	1	Hinge, Grass Discharge	57:1:3	1-513208	1	Washer-Spring Disc 5/8
26:3	3256-82	3	Washer	57:1:4	3219-6	1	Nut-Hex 5/8-18
26:4	104-8300	3	Nut-Nyloc 5/16-18 Flg	57:1:5	1-643393	1	Jackshaft ▲
26:5	3230-22	3	Bolt-Carriage 5/16-18 X 1 Sp	57:1:6	103-3046	1	Sheave, Jackshaft Double ▲
27	109-2796	2	Pulley,Idler 6"	58	323-6	5	Screw-HH 3/8-16 X 1
28	109-5532-01	1	Baffle, Scroll 72"	59	1-643052	1	Belt, Blade Drive 72"
29	109-6471	3	Blade-High Lift Solid, 24.75	60	116-9981	6	Kit, Anti-Scalp Roller
29	109-6465	3	Blade,High Lift Notched 24.75	61	103-9746	1	Asm, Jackshaft Housing
29	109-5879	3	Blade, Mulch 24.75 Mk725 ■				
29	103-9631	3	Blade, Extreme				

● Not serviced separately

■ Requires installation of mulch kit for proper mulching. See your Exmark dealer for details.

▲ Apply Mobil HTS grease (P/N 103-5217 1.5 oz packet) (or a food-grade anti-seize). See operator s manual for locations.

Deck W/Decals Assembly No. 109-2105

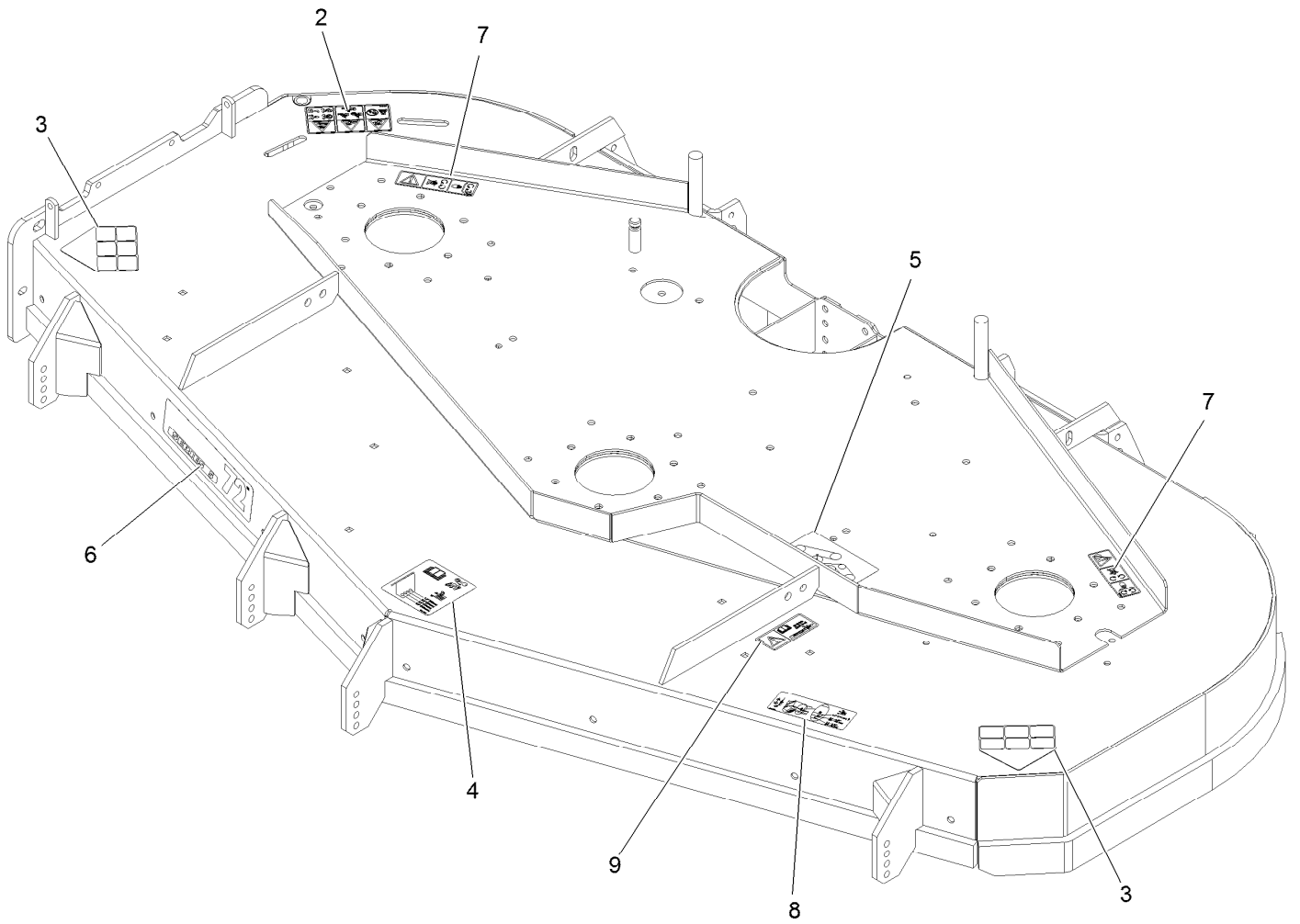

Deck W/Decals Assembly No. 109-2105 (continued)

<i>Ref.</i>	<i>Part Number</i>	<i>Qty.</i>	<i>Description</i>	<i>Ref.</i>	<i>Part Number</i>	<i>Qty.</i>	<i>Description</i>
2	117-3848	1	Decal-Danger	6	116-7118	1	Decal, Series 5 - 72
3	93-7316	2	Decal-Danger	7	112-9028	2	Decal-Cover Missing
4	126-4757	1	Decal-Height Of Cut	8	126-4754	1	Decal-Baffle Adj
5	126-4758	1	Decal-Belt Routing	9	116-8283	1	Decal-Bolt Torque

Idler Arm W/Bearings Kit No. 109-2095

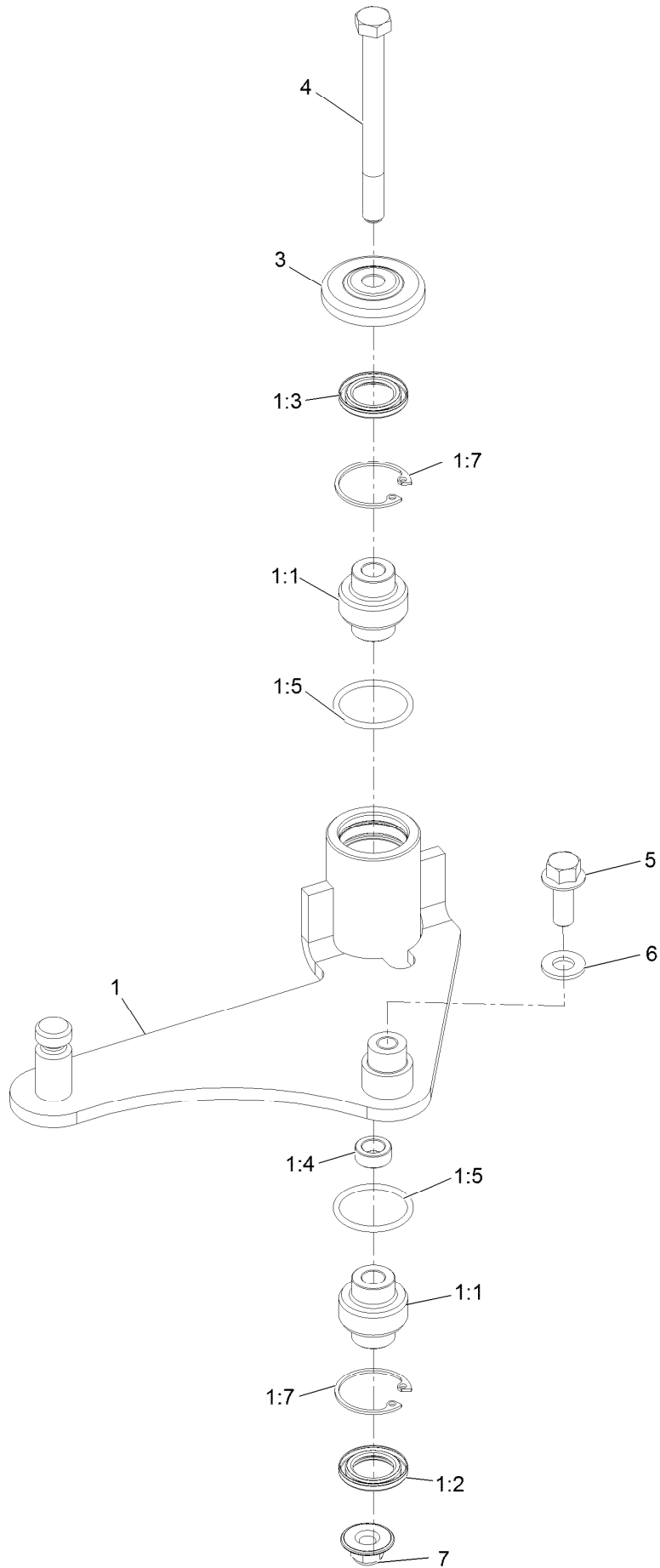

Idler Arm W/Bearings Kit No. 109-2095 (continued)

<i>Ref.</i>	<i>Part Number</i>	<i>Qty.</i>	<i>Description</i>	<i>Ref.</i>	<i>Part Number</i>	<i>Qty.</i>	<i>Description</i>
1		1	ASM,Deck Idler ●	1:7	32120-10	2	Ring-Retaining
1:1	103-3504	2	Bearing-Spherical	3	103-2916	1	Guard-Top
1:2	103-3505	1	Seal-Double Lip	4	98-5961	1	Screw-HH 3/8-16 X 4 Gr8
1:3	103-3506	1	Seal-Single Lip	5	3234-11	1	Screw-HH Flg 3/8-16 X 1
1:4	103-5677	1	Spacer	6	3256-24	1	Washer-3/8 Sae
1:5	106-7159	2	O-Ring	7	109-6658	1	Nut-Nyloc 3/8-16 Flg

● Not serviced separately

Cutter Housing Assembly No. 103-9539

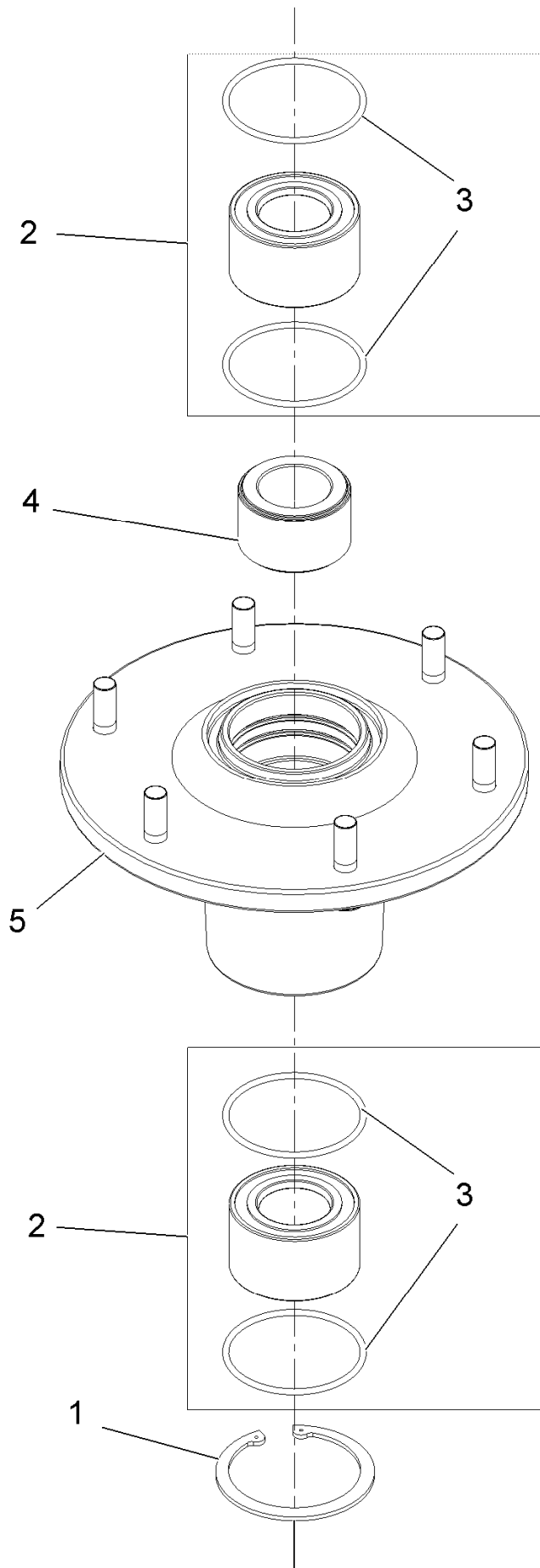

Cutter Housing Assembly No. 103-9539 (continued)

<i>Ref.</i>	<i>Part Number</i>	<i>Qty.</i>	<i>Description</i>	<i>Ref.</i>	<i>Part Number</i>	<i>Qty.</i>	<i>Description</i>
1	92-5581	1	Ring-Retaining	4	103-9506	1	Spacer, Bearing
2	109-2064	1	Asm, Bearing W/O-Rings	5	109-0764	1	Asm, Housing W/Studs
3	103-5895	4	O-Ring				

Front Frame Assembly

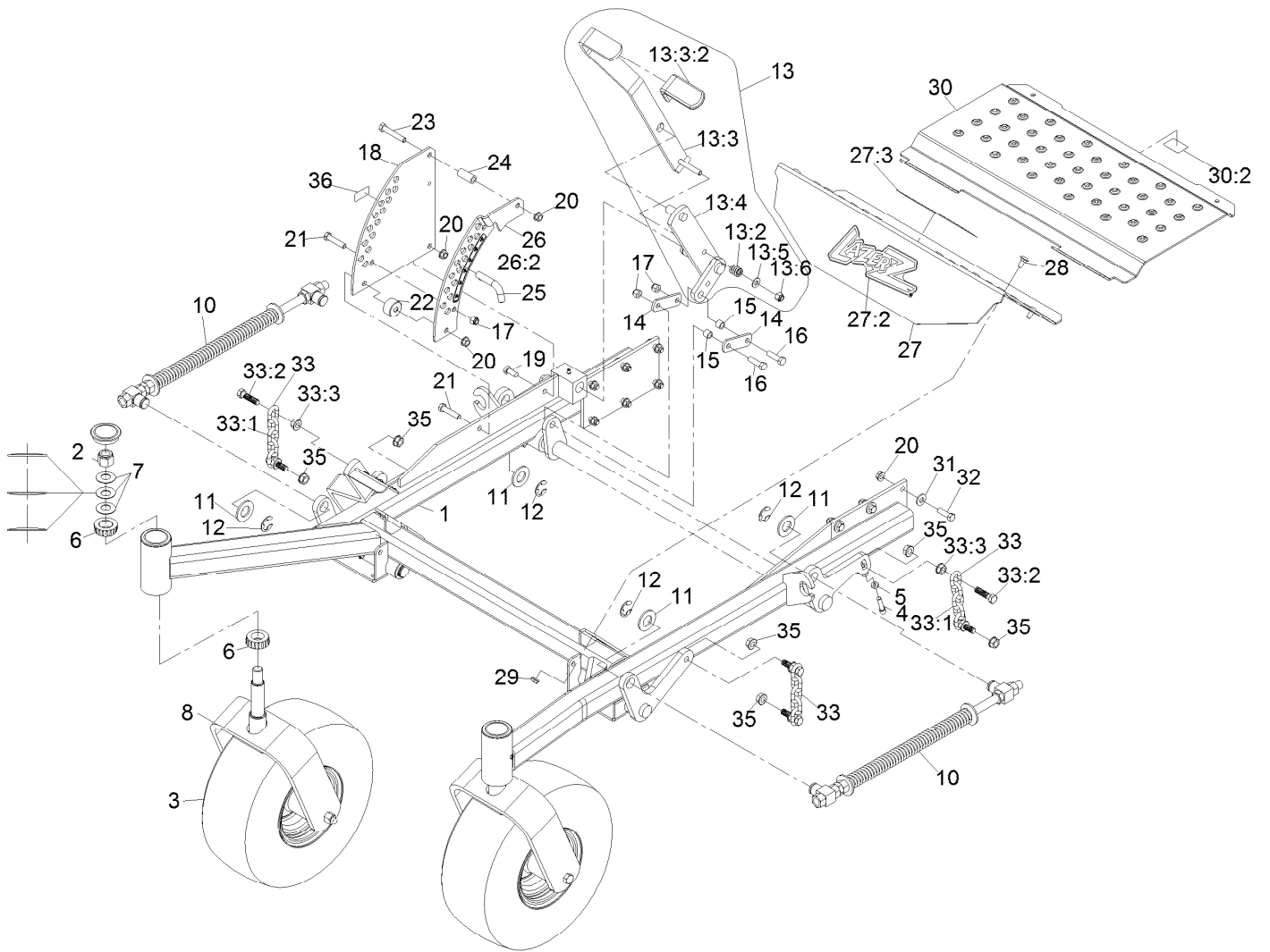

Front Frame Assembly (continued)

<i>Ref.</i>	<i>Part Number</i>	<i>Qty.</i>	<i>Description</i>	<i>Ref.</i>	<i>Part Number</i>	<i>Qty.</i>	<i>Description</i>
1	116-9499	1	ASM-Frt Frm 725	20	3290-357	15	Nut-Whizlock 3/8-16
2	3296-51	2	Nut-Nyloc 3/4-10	21	323-9	1	Screw-HH 3/8-16 X 1 3/4
3	109-9127	2	Wheel & Tire ASM	22	109-3193	1	Stop, Deck Height
4	3274-18	2	Screw-Sh 5/16-18 X 1 1/4	23	323-11	1	Screw-HH 3/8-16 X 2 1/4
5	3218-2	2	Nut-Jam 5/16-18	24	1-633082	1	Bushing
6	1-543509	4	Cone-Bearing Tapered Roller	25	116-5584	1	Pin-HOC
7	1-633508	6	Washer-Spring Disc	26	116-9124	1	Plate-Lift, Deck W/Decal
8	116-6707-01	2	Caster	26:2	126-4664	1	Decal-Height Of Cut
10	109-4995	2	Asm, Front Frame Spring	27	109-1903	1	Asm, Floorpan (103-8274-01) W/Decals
11	3256-29	4	Washer-7/8 Sae	27:2	103-3113	1	Decal, Lazer Model
12	32151-103	5	E-Ring	27:3	127-0335	1	Decal - Warning, Slope
13	109-4488	1	ASM,Deck Lift Handle	28	3230-1	4	Bolt-Carriage 5/16-18 X 3/4
13:2	1-633325	1	Spring-Compression	29	32128-20	4	Nut-Whizlock 5/16-18
13:3	103-2084	1	Lift Lever/Grip ASM	30	109-1902	1	Asm, Floorpan, Liftout (103-8276-01) W/Decal
13:3:2	1-633295	1	Grip-Lever, Lift	30:2	126-4748	1	Decal-Guard
13:4	109-4487	1	Wld,Arm Deck Lift	31	98-5975	12	Washer-Spring Disc 3/8
13:5	3256-24	1	Washer-3/8 Sae	32	323-7	12	Screw-HH 3/8-16 X 1 1/4
13:6	3296-39	1	Nut-Nyloc 3/8-16	33	103-9792	4	Deck Chain ASM
14	1-633068	2	Arm-Lift, Deck	33:1	1-633447	1	Chain-Lift, Deck
15	103-1918	2	Bushing	33:2	103-1898	2	Screw-HH 7/16-20 X 1-5/8 Sp
16	323-29	2	Screw-HH 3/8-16 X 1 3/8	33:3	32128-37	2	Nut-Whizlock 7/16-14
17	3296-39	2	Nut-Nyloc 3/8-16	35	32128-37	8	Nut-Whizlock 7/16-14
18	116-9122-01	1	Plate-Deck Lift Notched Outer	36	126-4345	1	Decal-Patent Ttco.Com
19	323-5	1	Screw-HH 3/8-16 X 7/8				

Front Frame Assembly No. 116-9499

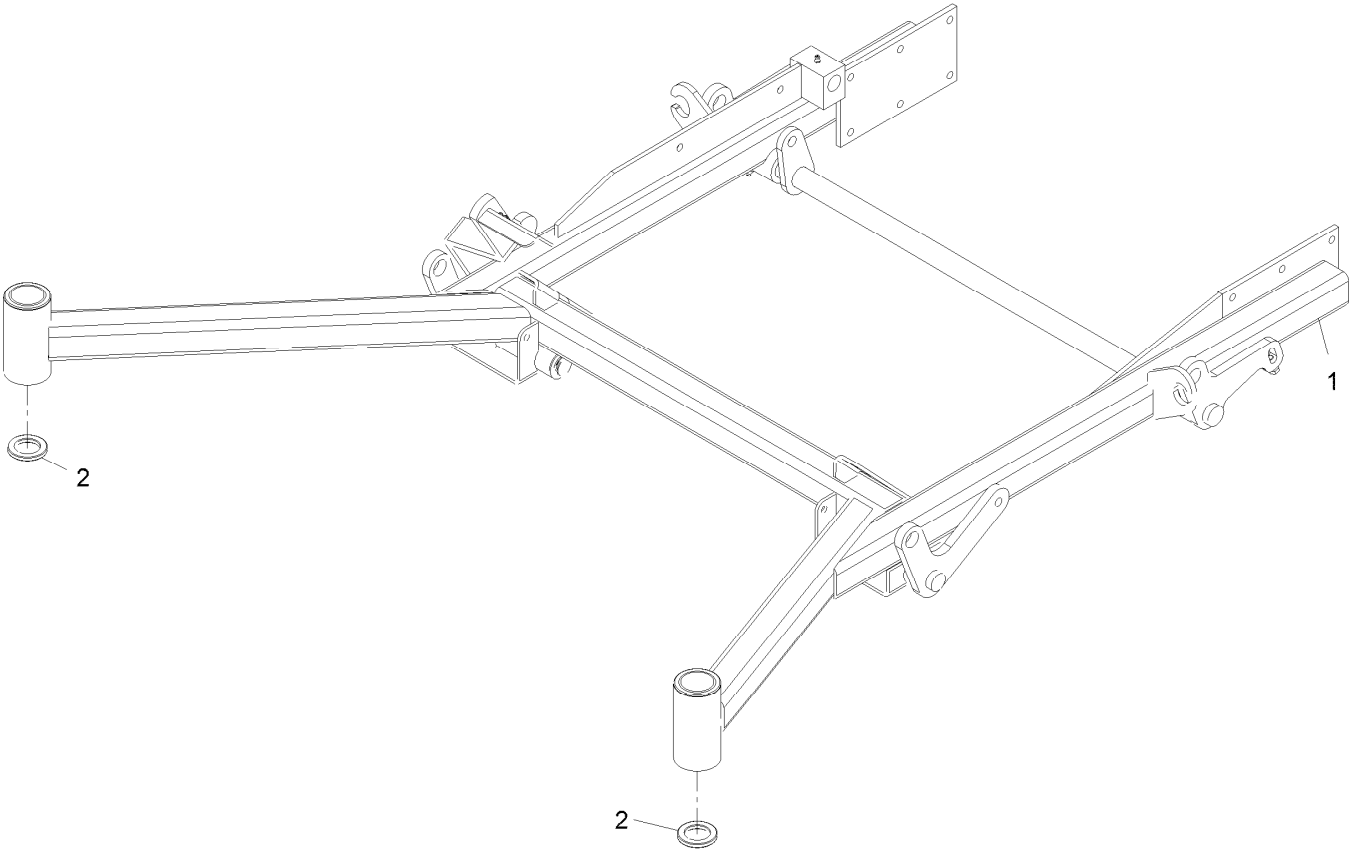

Front Frame Assembly No. 116-9499 (continued)

<i>Ref.</i>	<i>Part Number</i>	<i>Qty.</i>	<i>Description</i>
1		1	ASM-Front Frame 725 ●
2	1-543511	2	Seal-Grease

● Not serviced separately

Front Frame Assembly (cont)

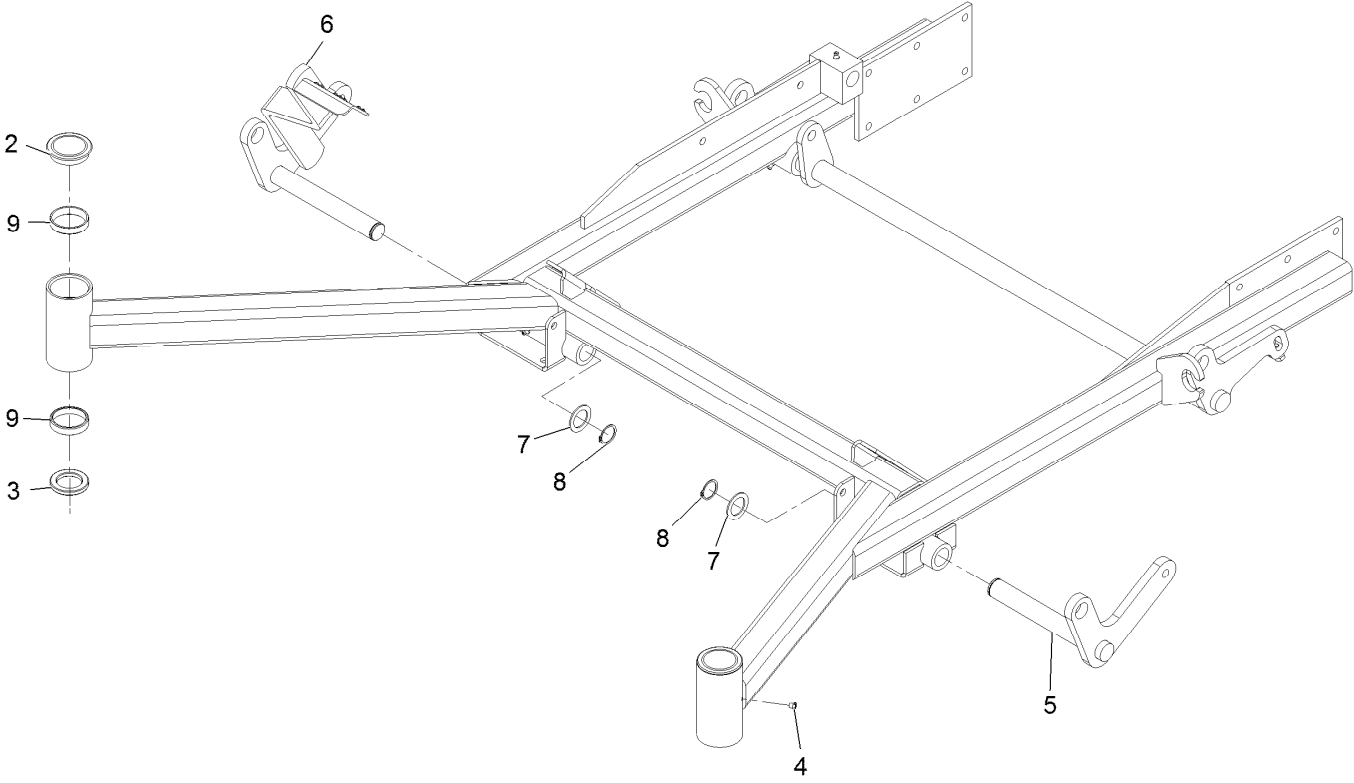

Front Frame Assembly (cont) (continued)

<i>Ref.</i>	<i>Part Number</i>	<i>Qty.</i>	<i>Description</i>	<i>Ref.</i>	<i>Part Number</i>	<i>Qty.</i>	<i>Description</i>
2	103-4882	2	Cap-Grease	7	1-523157	2	Washer
3	116-5647	2	Seal-Grease	8	32151-29	2	Ring-Retaining
4	1-811010	2	Plug	9	1-543508	4	Cup-Bearing Tapered Roller
5	103-9741-01	1	Weldmt, Front Lift Shaft (LH)				
6	103-9740-01	1	Weldmt, Front Lift W/Lever(RH)				

Wheel and Tire Assembly No. 109-9127

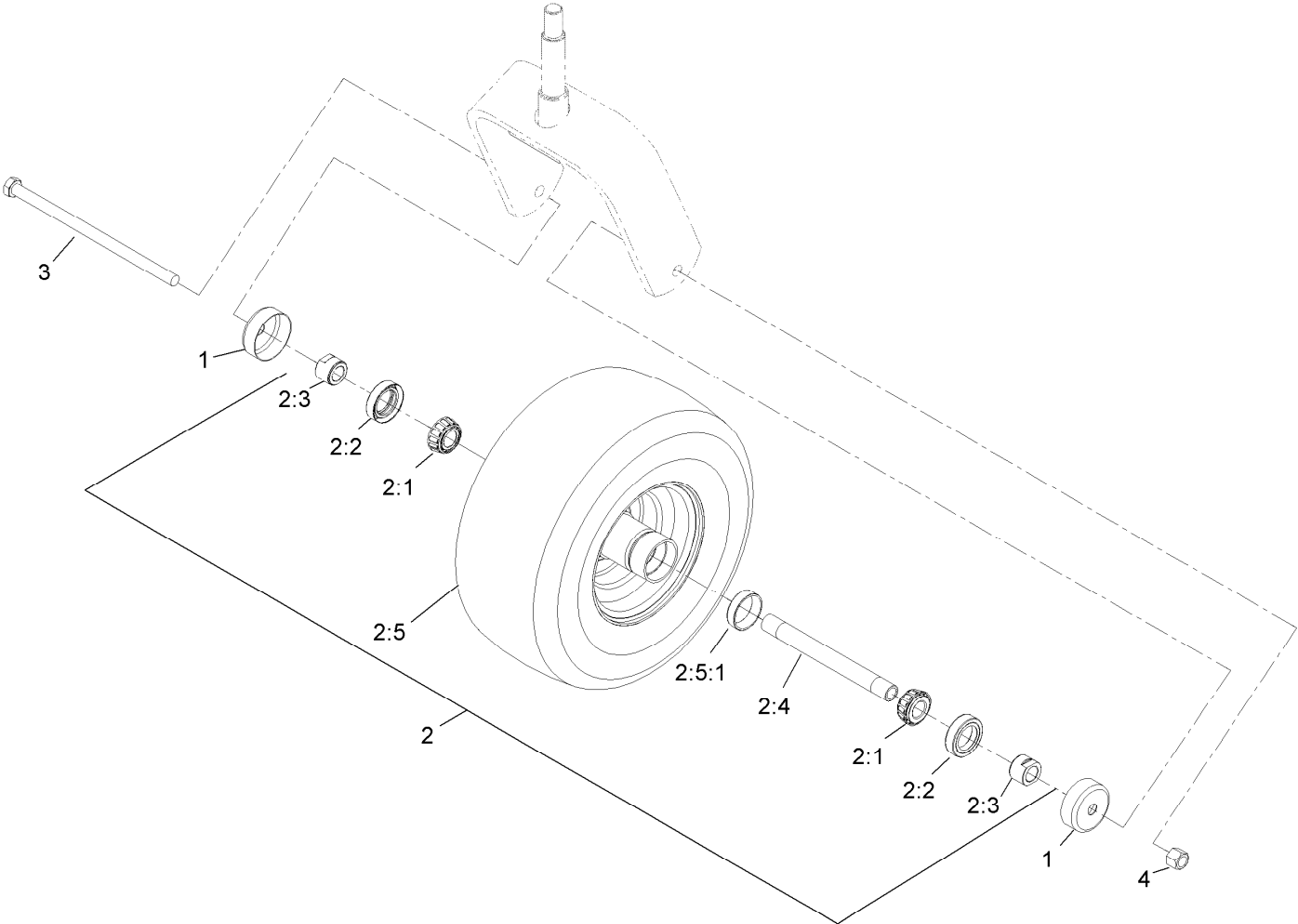

Wheel and Tire Assembly No. 109-9127 (continued)

<i>Ref.</i>	<i>Part Number</i>	<i>Qty.</i>	<i>Description</i>	<i>Ref.</i>	<i>Part Number</i>	<i>Qty.</i>	<i>Description</i>
1	103-2768	2	Guard-Seal	2:4	103-5156	1	Axle-Caster
2		1	Wheel And Tire ASM ●	2:5		1	Wheel And Tire ASM ●
2:1	1-633585	2	Bearing-Cone Tapered Roller	2:5:1	1-633584	1	Bearing-Cup
2:2	103-0063	2	Seal-Double Lip	3	325-39	1	Screw-HH 1/2-13 X 9 1/2
2:3	103-3051	2	Spacer-Nut ■	4	3296-23	1	Nut-Nyloc 1/2-13

● Not serviced separately

■ Use Pro-Lock, Nut Type (P/N 1-840022, .5ml tube) on threads.

Front Frame Spring Assembly No. 109-4995

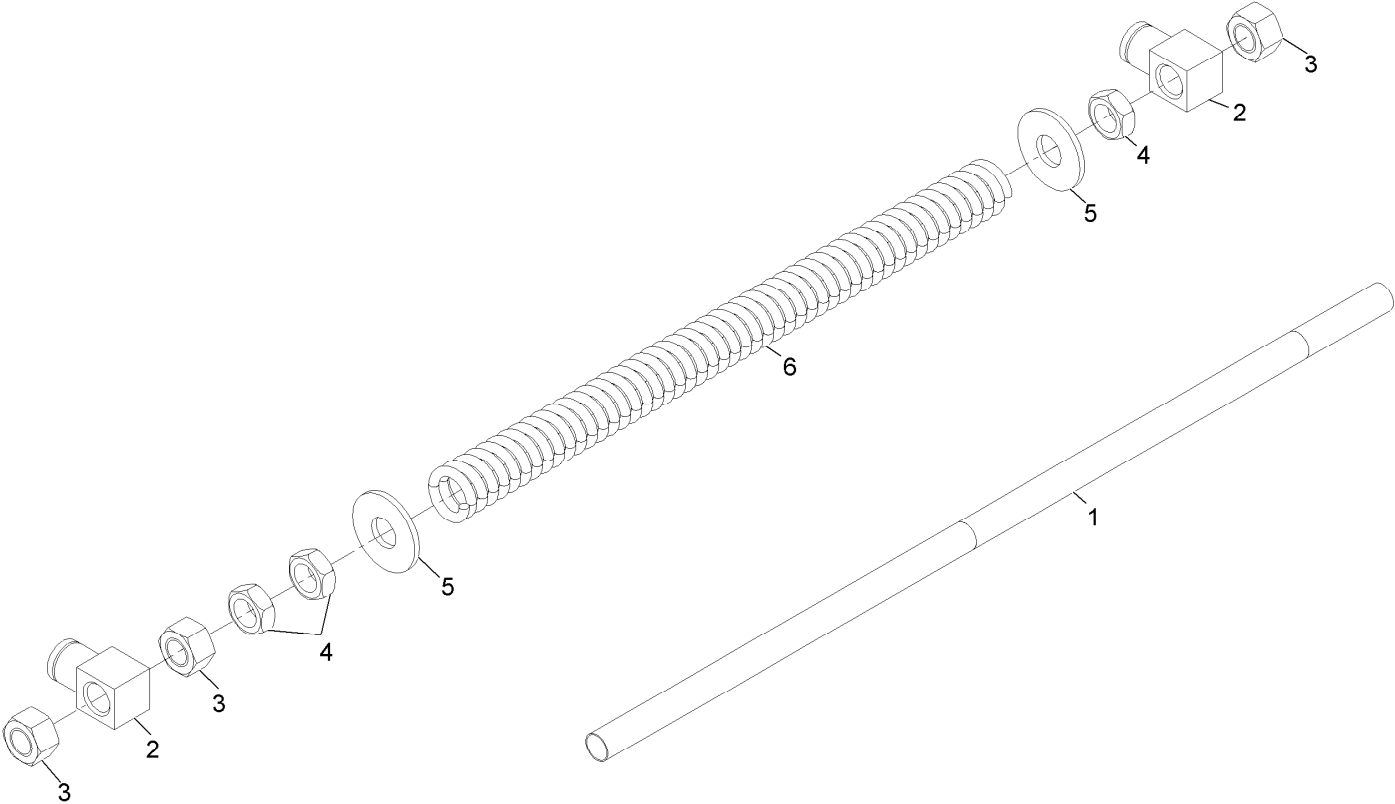

Front Frame Spring Assembly No. 109-4995 (continued)

<i>Ref.</i>	<i>Part Number</i>	<i>Qty.</i>	<i>Description</i>	<i>Ref.</i>	<i>Part Number</i>	<i>Qty.</i>	<i>Description</i>
1	1-633096	1	Rod-Lift, Deck	4	3218-6	3	Nut-Jam 5/8-11
2	1-633441	2	Swivel-Deck Mount, Rear	5	3256-7	2	Washer-5/8 Std
3	3217-11	3	Nut-Hex 5/8-11	6	109-4963	1	Spring, Deck Support

Main Frame Assembly

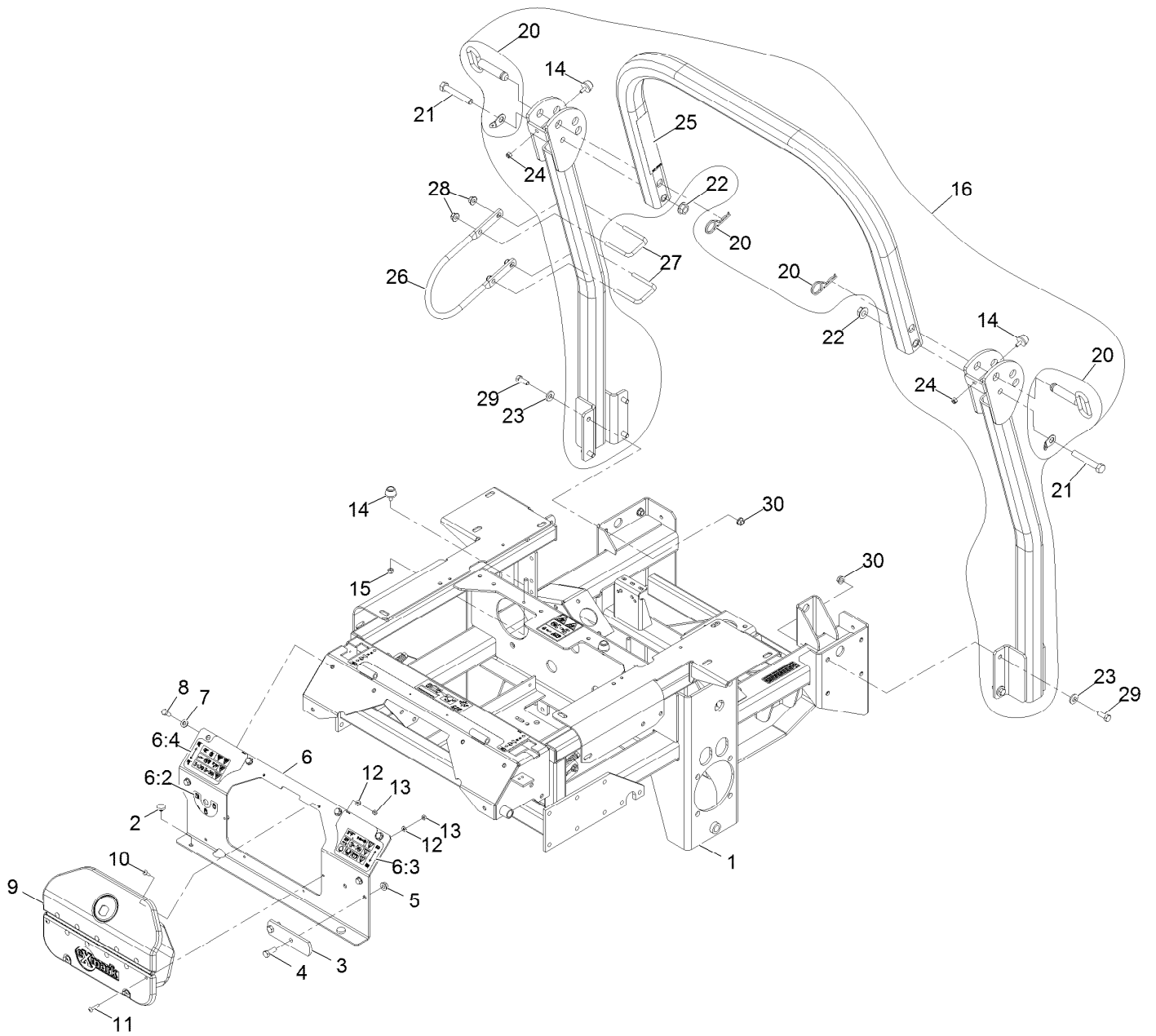

Main Frame Assembly (continued)

<i>Ref.</i>	<i>Part Number</i>	<i>Qty.</i>	<i>Description</i>	<i>Ref.</i>	<i>Part Number</i>	<i>Qty.</i>	<i>Description</i>
1	109-3984	1	Asm, Engine Deck (109-3985-03) W/Decals	12	3256-14	6	Washer-#10 Std
2	1-513658	2	Bumper	13	3296-2	6	Nut-Nyloc #10-24
3	1-633964-03	1	Stop-Brake, Park	14	109-2365	4	Bumper-Rubber
4	323-6	2	Screw-HH 3/8-16 X 1	15	3296-42	2	Nut-Nyloc 1/4-20
5	3290-357	2	Nut-Whizlock 3/8-16	16	109-0060	1	Kit, Xp Rops ●
6	109-2075	1	Asm, Console(103-8273-03) W/Decals	20	103-4553	2	Pin-Fold, ROPS
6:2	126-4848	1	Decal-Fuel	21	325-13	2	Screw-HH 1/2-13 X 3 1/4
6:3	126-4755	1	Decal-Console LH	22	32128-23	2	Nut-Hex 1/2-13 Side Lock
6:4	126-4756	1	Decal-Console RH	23	98-5975	8	Washer-Spring Disc 3/8
7	3256-23	6	Washer-5/16 Sae	24	3296-73	2	Nut-Nyloc 1/4-20
8	322-3	6	Screw-HH 5/16-18 X 3/4	25	107-3069	1	Decal-Warning, Folding ROPS
9	103-3666	1	Asm, Cubby	26	103-7599-03	1	Guard
10	1-803075	2	Screw-Truss Head #10-24 X 3/4	27	109-2394	2	U-Bolt
11	32122-28	4	Screw-Truss HD #10-24 X 1	28	104-8301	4	Nut-Nyloc 3/8-16 Flg
				29	323-6	8	Screw-HH 3/8-16 X 1
				30	3290-357	8	Nut-Whizlock 3/8-16

● Includes seat belt assembly

Neutral Return Assembly No. 109-3903

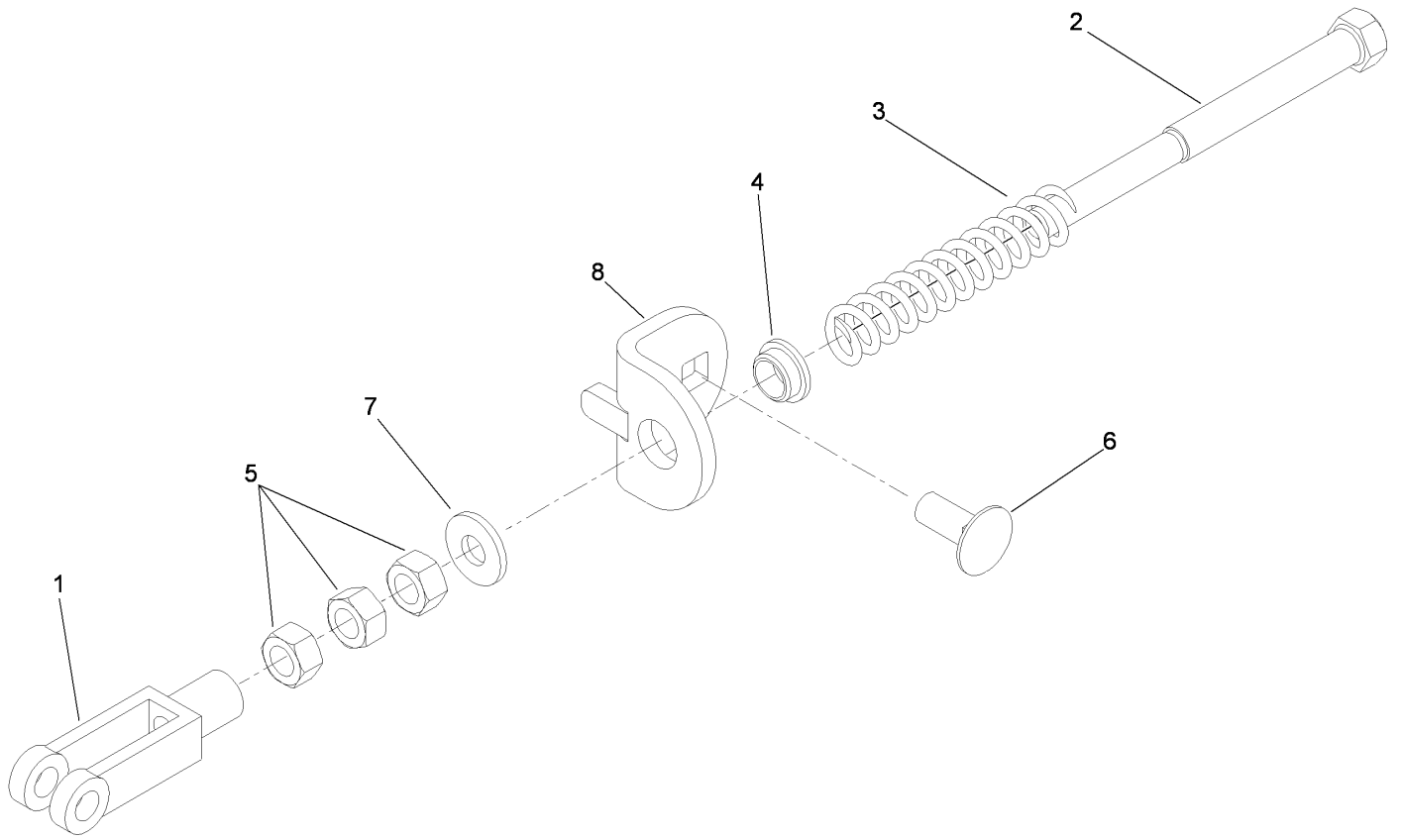

Neutral Return Assembly No. 109-3903 (continued)

<i>Ref.</i>	<i>Part Number</i>	<i>Qty.</i>	<i>Description</i>	<i>Ref.</i>	<i>Part Number</i>	<i>Qty.</i>	<i>Description</i>
1	1-303105	1	Yoke-Adjustable	5	3219-2	3	Nut-Hex
2	1-603737	1	Bolt-Return, Neutral	6	3230-23	1	Screw-CARR
3	1-603807	1	Spring-Return, Neutral	7	3256-2	1	Washer-Flat
4	109-3769	1	Bushing-Nylon, Flanged	8	109-3908	1	Tab-Adjustment

Engine Deck W/Decals Assembly No. 109-3984

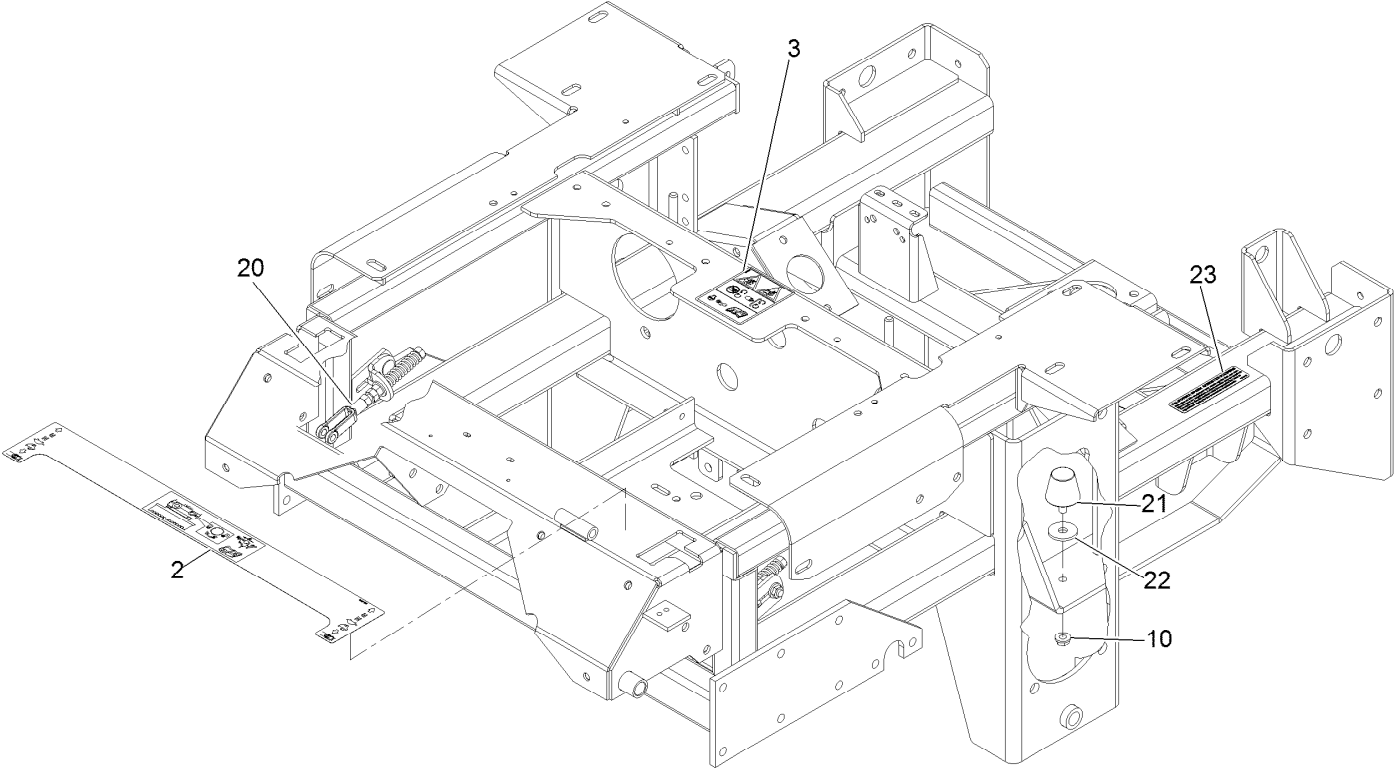

Engine Deck W/Decals Assembly No. 109-3984 (continued)

<i>Ref.</i>	<i>Part Number</i>	<i>Qty.</i>	<i>Description</i>	<i>Ref.</i>	<i>Part Number</i>	<i>Qty.</i>	<i>Description</i>
2	126-4743	1	Decal-Console Center	20	109-3903	2	Neutral Return ASM
3	126-4859	1	Decal-Rotating Device Hazard	21	1-543963	1	Bumper-Rubber
10	32128-20	3	Nut-Whizlock 5/16-18	22	63-8410	1	Washer
				23	117-2718	1	Decal-Arrester, Spark

Motion Control Assembly

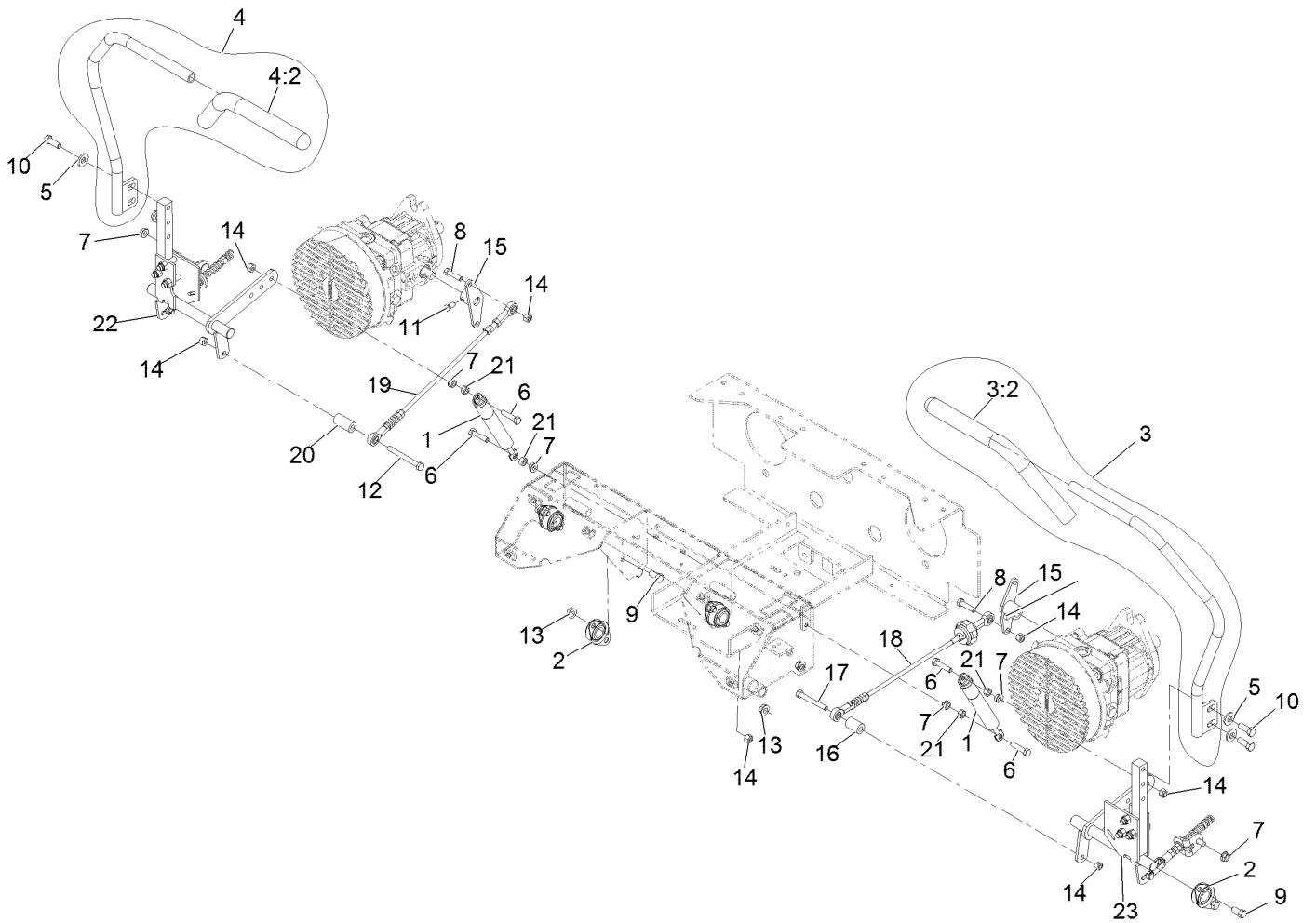

Motion Control Assembly (continued)

<i>Ref.</i>	<i>Part Number</i>	<i>Qty.</i>	<i>Description</i>	<i>Ref.</i>	<i>Part Number</i>	<i>Qty.</i>	<i>Description</i>
1	109-2339	2	Damper-Control, Motion	10	323-6	4	Screw-HH 3/8-16 X 1
2	1-633102	4	Bearing-Flanged	11	1-803022	2	Setscrew-5/16-18 X 5/8 ●
3	103-3457	1	Handle (103-3326-03) W/Grip (LH)	12	322-14	1	Screw-HH 5/16-18 X 3
3:2	103-3456	1	Grip, Motion Control Handle	13	3290-357	8	Nut-Whizlock 3/8-16
4	103-3458	1	Handle (103-3327-03) W/Grip (RH)	14	3296-29	8	Nut-Nyloc 5/16-18
4:2	103-3456	1	Grip, Motion Control Handle	15	103-0194-03	2	Arm-Control, Hydro
5	98-5975	4	Washer-Spring Disc 3/8	16	103-1361	1	Spacer
6	1-403180	4	Screw-HH 5/16-18 X 1 3/8 Special	17	322-12	1	Screw-HH 5/16-18 X 2 1/2
7	32128-20	6	Nut-Whizlock 5/16-18	18	103-3062	1	Tracking Rod ASM
8	322-6	2	Screw-HH 5/16-18 X 1 1/4	19	103-5190	1	RH HYD Connect Link ASM
9	323-4	8	Screw-HH 3/8-16 X 3/4	20	103-5192	1	Spacer-Control, HYD
				21	3217-6	4	Nut-Hex 5/16-18
				22	109-3978	1	RH Motion Control ASM
				23	109-3979	1	LH Motion Control ASM

● Use Pro-Lock, Nut Type (P/N 1-840022, .5ml tube) on threads.

LH Motion Control Assembly No. 109-3979

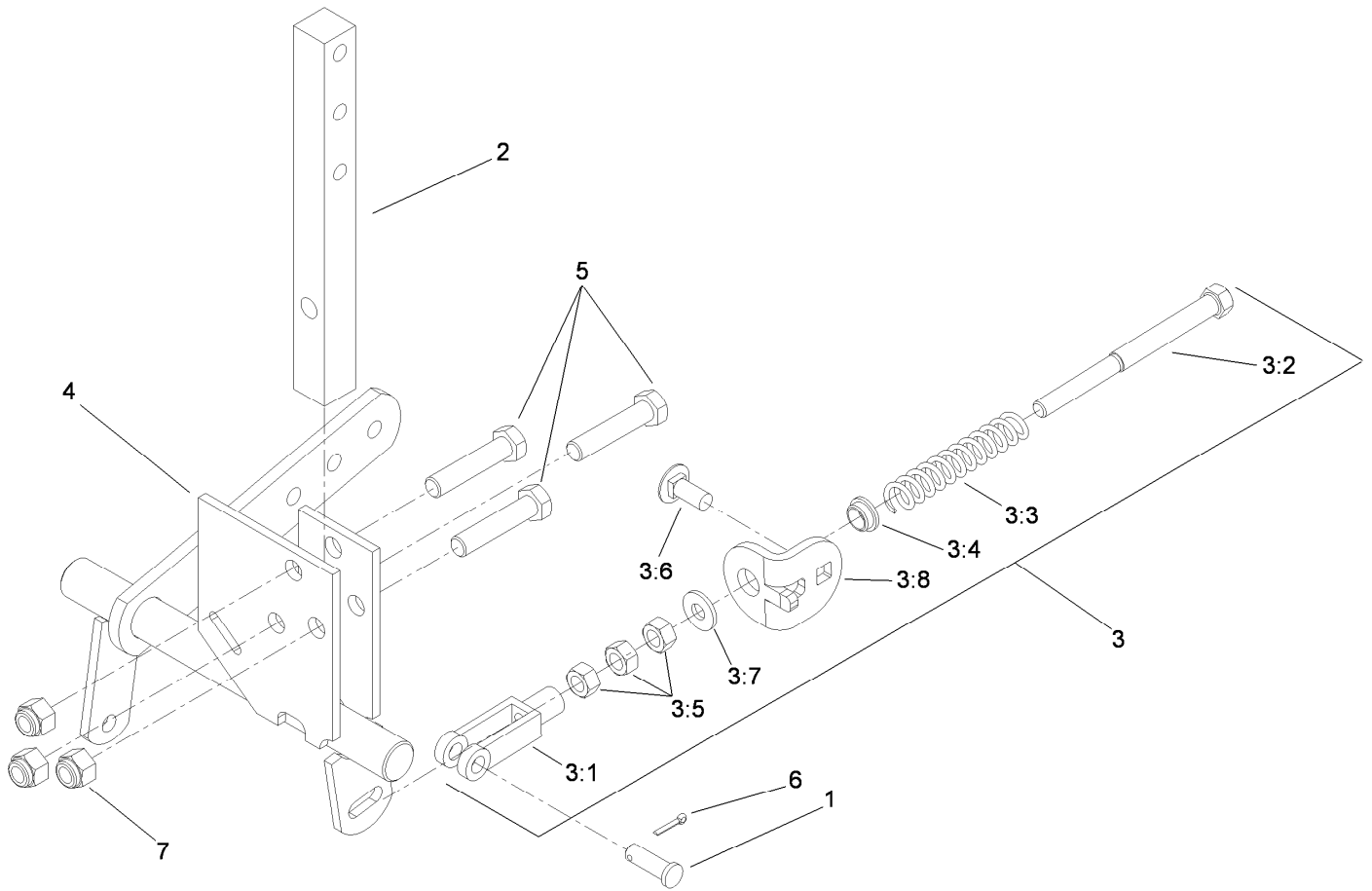

LH Motion Control Assembly No. 109-3979 (continued)

<i>Ref.</i>	<i>Part Number</i>	<i>Qty.</i>	<i>Description</i>	<i>Ref.</i>	<i>Part Number</i>	<i>Qty.</i>	<i>Description</i>
1	1-808280	1	Pin-Clevis	3:6	3230-23	1	Screw-CARR
2	103-0407	1	Arm-Shaft, Control	3:7	3256-2	1	Washer-Flat
3	109-3903	1	Neutral Return ASM	3:8	109-3908	1	Tab-Adjustment
3:1	1-303105	1	Yoke-Adjustable	4	109-3983	1	Control-Motion, LH
3:2	1-603737	1	Bolt-Return, Neutral	5	323-9	3	Screw-HH
3:3	1-603807	1	Spring-Return, Neutral	6	3272-5	1	Pin-Cotter
3:4	109-3769	1	Bushing-Nylon, Flanged	7	3296-39	3	Nut-Lock, NI
3:5	3219-2	3	Nut-Hex				

RH Motion Control Assembly No. 109-3978

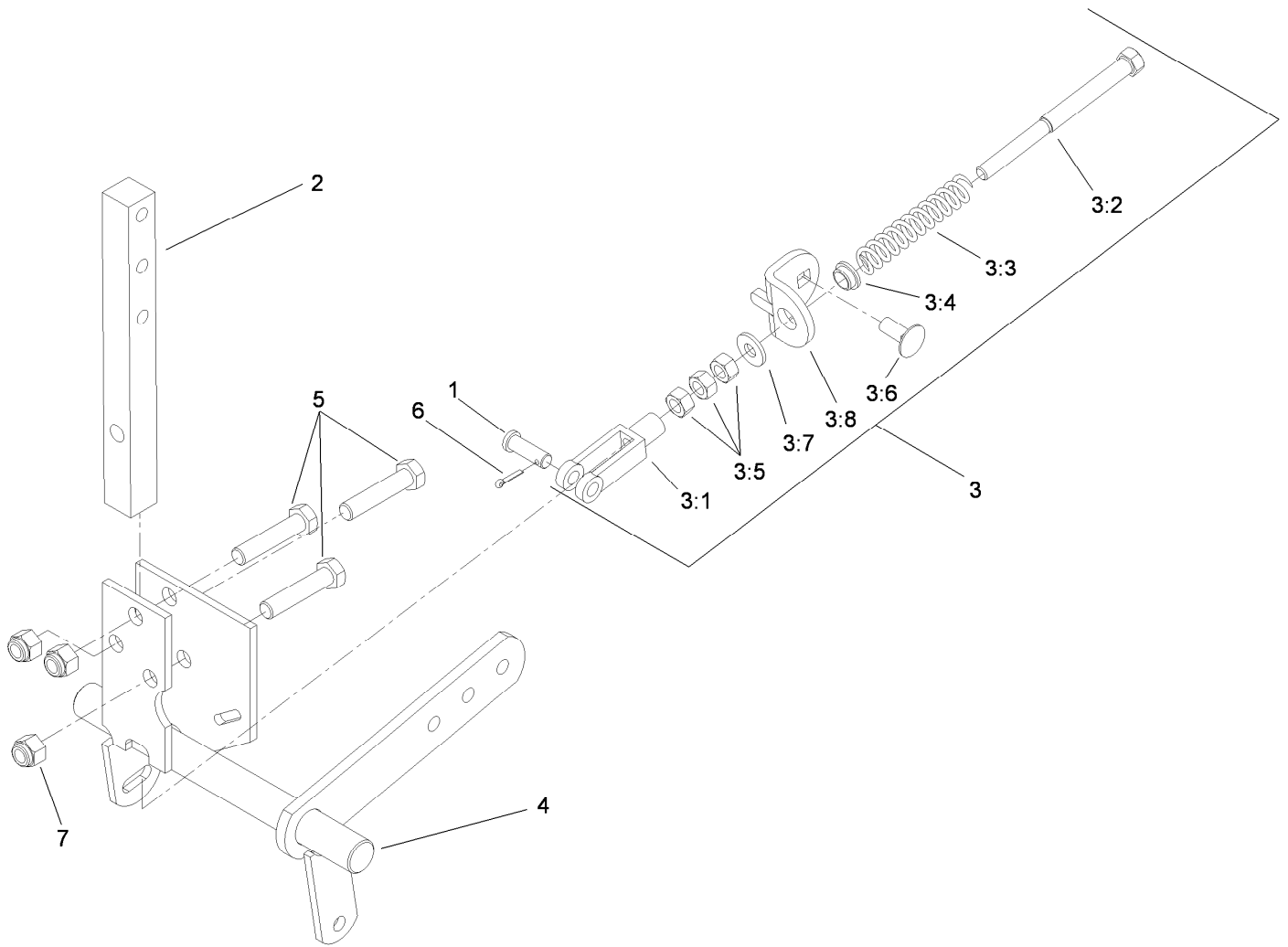

RH Motion Control Assembly No. 109-3978 (continued)

<i>Ref.</i>	<i>Part Number</i>	<i>Qty.</i>	<i>Description</i>	<i>Ref.</i>	<i>Part Number</i>	<i>Qty.</i>	<i>Description</i>
1	1-808280	1	Pin-Clevis	3:6	3230-23	1	Screw-CARR
2	103-0407	1	Arm-Shaft, Control	3:7	3256-2	1	Washer-Flat
3	109-3903	1	Neutral Return ASM	3:8	109-3908	1	Tab-Adjustment
3:1	1-303105	1	Yoke-Adjustable	4	109-3980	1	Control-Motion, RH
3:2	1-603737	1	Bolt-Return, Neutral	5	323-9	3	Screw-HH
3:3	1-603807	1	Spring-Return, Neutral	6	3272-5	1	Pin-Cotter
3:4	109-3769	1	Bushing-Nylon, Flanged	7	3296-39	3	Nut-Lock, NI
3:5	3219-2	3	Nut-Hex				

Tracking Rod Assembly No. 103-3062

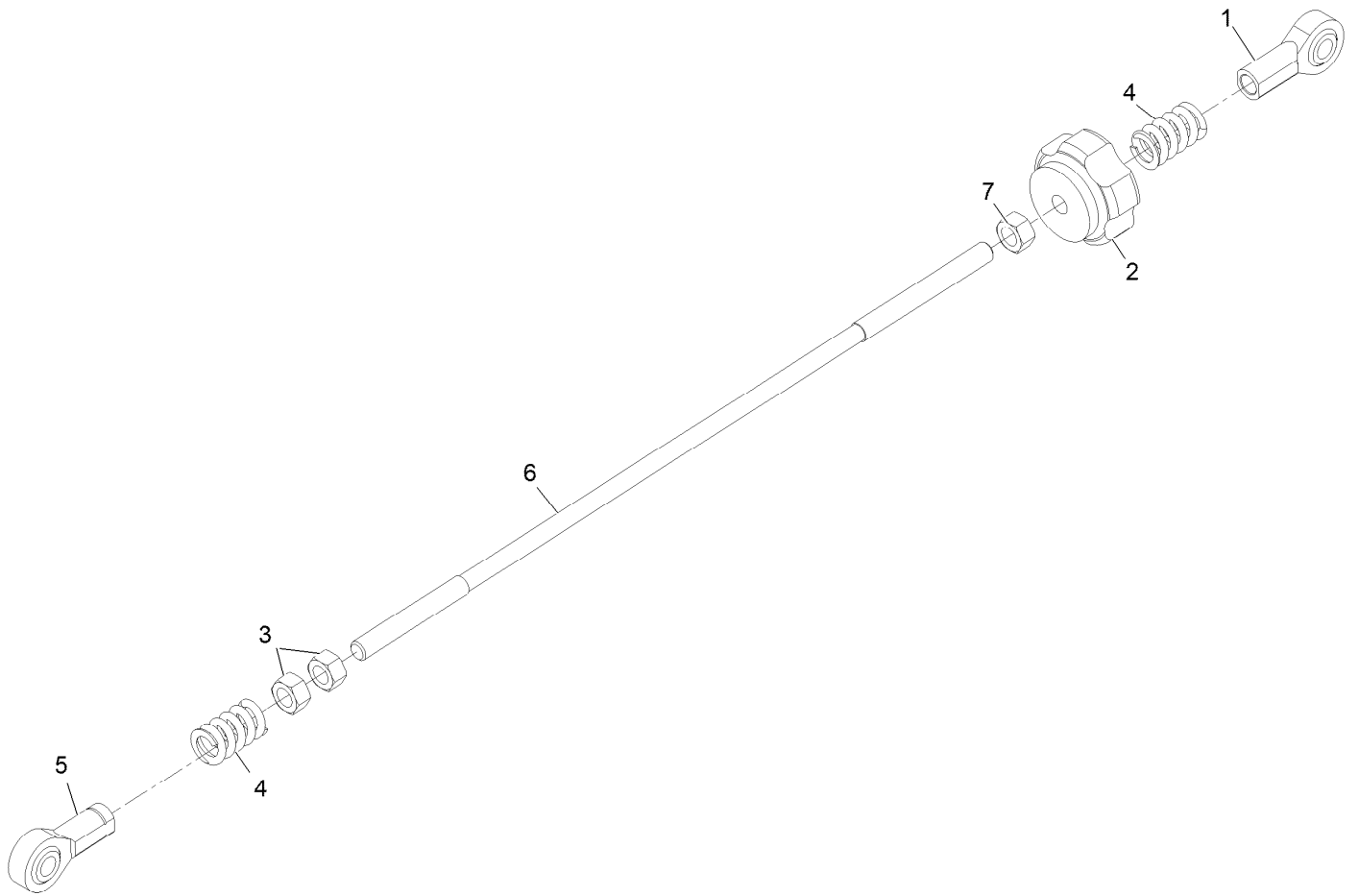

Tracking Rod Assembly No. 103-3062 (continued)

<i>Ref.</i>	<i>Part Number</i>	<i>Qty.</i>	<i>Description</i>	<i>Ref.</i>	<i>Part Number</i>	<i>Qty.</i>	<i>Description</i>
1	1-543017	1	Balljoint	5	1-633152	1	Balljoint
2	103-3060	1	Knob-Tracking	6	103-3065	1	Link, Hydro Connecting (LH)
3	1-804524	2	Nut-Hex 5/16-24 (LH)	7	3219-2	1	Nut-Hex 5/16-24
4	1-323245	2	Spring-Compression				

RH Hydro Connecting Link Assembly No. 103-5190

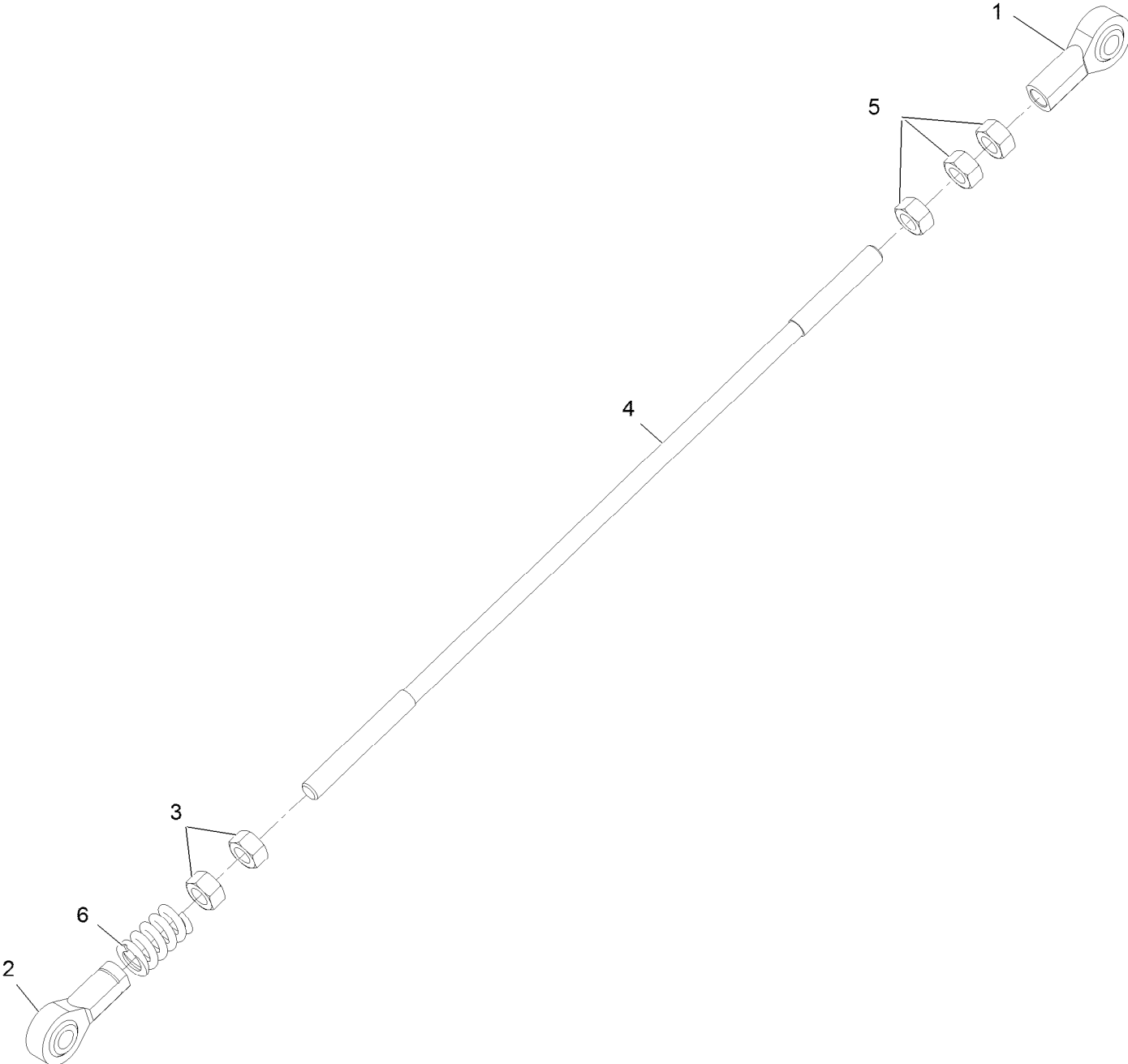

RH Hydro Connecting Link Assembly No. 103-5190 (continued)

<i>Ref.</i>	<i>Part Number</i>	<i>Qty.</i>	<i>Description</i>
1	1-543017	1	Balljoint
2	1-633152	1	Balljoint
3	1-804524	2	Nut-Hex 5/16-24 (LH)
4	103-5182	1	Link, Hydro Connecting (RH)

<i>Ref.</i>	<i>Part Number</i>	<i>Qty.</i>	<i>Description</i>
5	3219-2	3	Nut-Hex 5/16-24
6	1-323245	1	Spring-Compression

Park Brake Assembly

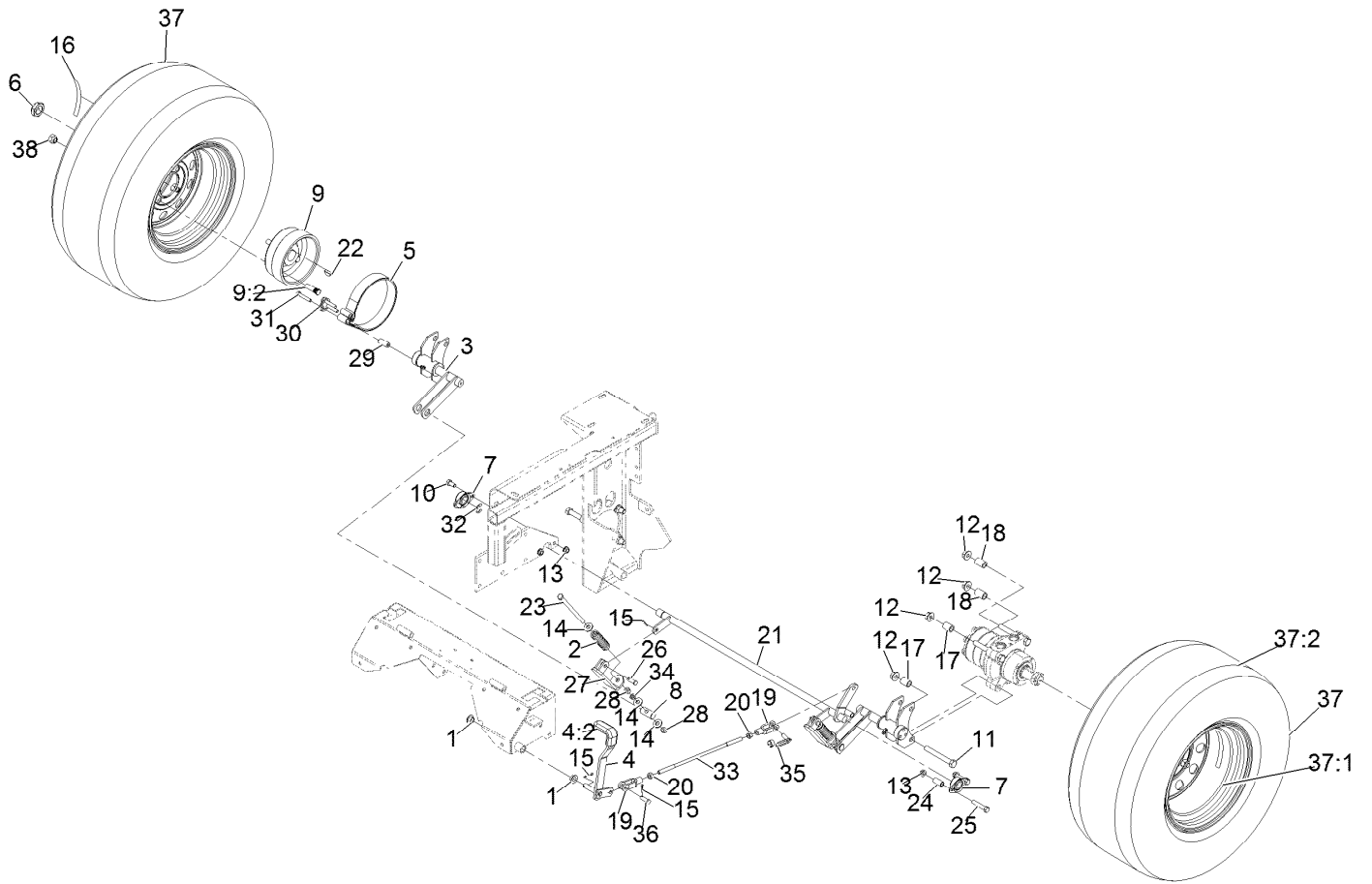

Park Brake Assembly (continued)

<i>Ref.</i>	<i>Part Number</i>	<i>Qty.</i>	<i>Description</i>	<i>Ref.</i>	<i>Part Number</i>	<i>Qty.</i>	<i>Description</i>
1	1-513140	2	Bearing	20	3219-3	2	Nut-Hex 3/8-24
2	109-2230	2	Spring-Compression	21	103-5243-03	1	Shaft-Brake
3	103-0810-03	2	Brake-Wide	22	3257-42	2	Key-Woodruff 5/16 X 1
4	103-0197	1	Brake Lever And Grip ASM	23	323-58	2	Bolt-HH 3/8-16 X 6 Tap
4:2	1-633268	1	Grip-Lever	24	103-0051	2	Spacer-Retainer, Brake
5	103-9761	2	Band, Brake	25	323-10	2	Screw-HH 3/8-16 X 2
6	116-1399	2	Locknut	26	1-808284	2	Pin-Clevis
7	1-633102	2	Bearing-Flanged	27	103-1117-03	2	Linkage-Brake, Lower
8	1-633144	2	Pin-Trunion	28	3296-39	4	Nut-Nyloc 3/8-16
9	116-2291	2	Hub W/Studs ASM	29	103-0384	6	Spacer
9:2	1-633926	4	Stud-Wheel	30	103-0374	2	Retainer-Band, Brake
10	323-4	2	Screw-HH 3/8-16 X 3/4	31	322-9	6	Screw-HH 5/16-18 X 1 3/4
11	325-20	8	Screw-HH 1/2-13 X 6	32	32151-48	1	E-Ring
12	32128-49	8	Nut-Whizlock 1/2-13	33	103-1708	1	Rod-Brake
13	3290-357	4	Nut-Whizlock 3/8-16	34	3218-3	2	Nut-Jam 3/8-16
14	3256-4	6	Washer-3/8 Std	35	103-2399	1	Pin-Clevis Spring 3/8
15	3272-10	4	Pin-Cotter 1/8 X 3/4	36	1-808285	1	Pin-Clevis 3/8 X 1 1/8
16	126-2055	2	Decal-Torque Wheel Lug-Hub	37	109-3157	2	Wheel And Tire ASM
17	109-5011	4	Spacer-Wheel, Short	37:1	109-3156	1	Rim
18	109-5012	4	Spacer-Wheel, Long	37:2	103-4963	1	Tire
19	1-633131	2	Yoke-Linkage, Brake	38	242-50	8	Nut-Lug 1/2-20

Seat Assembly

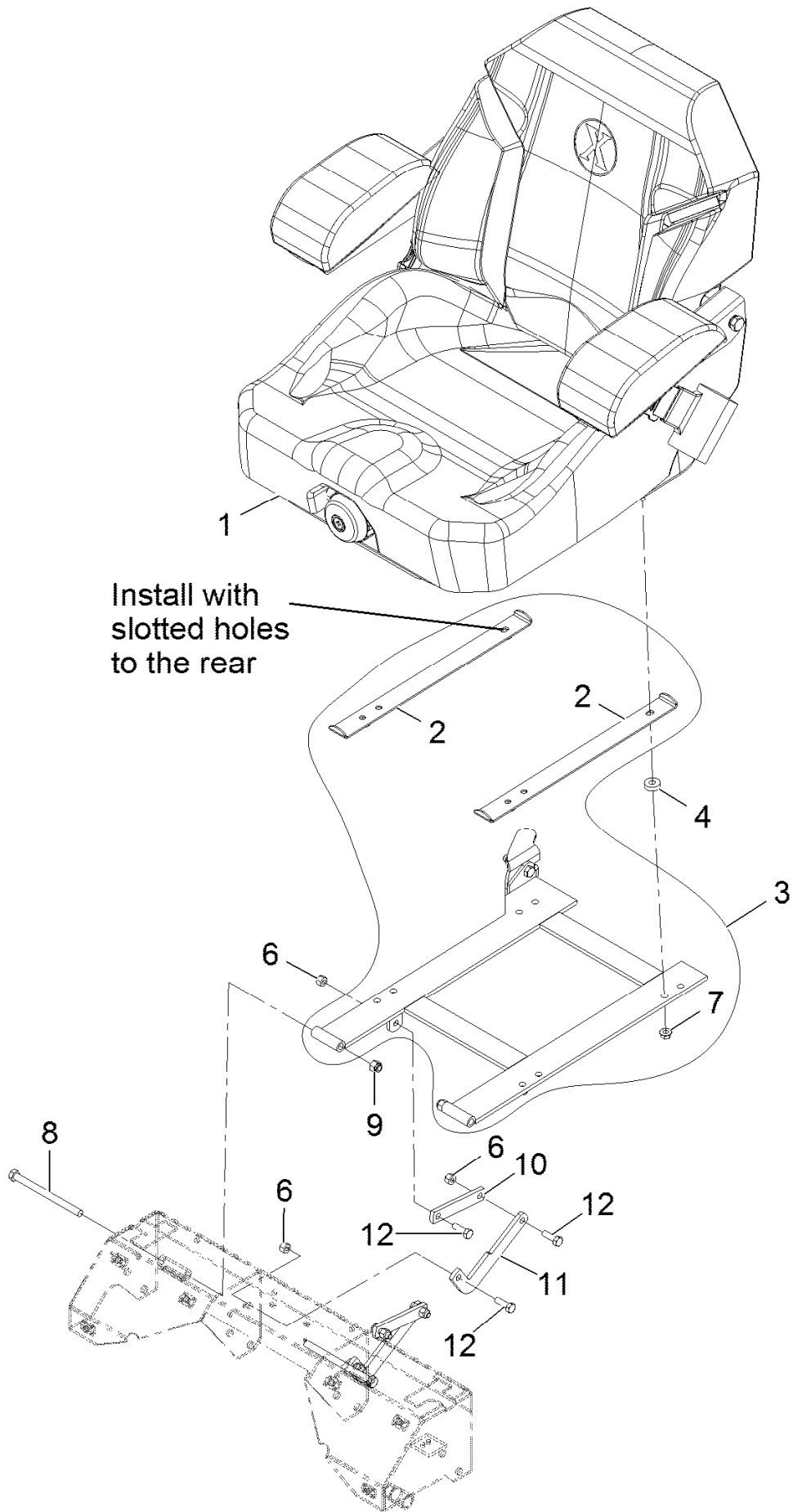

Seat Assembly (continued)

<i>Ref.</i>	<i>Part Number</i>	<i>Qty.</i>	<i>Description</i>	<i>Ref.</i>	<i>Part Number</i>	<i>Qty.</i>	<i>Description</i>
1	116-8912	1	Kit-Suspension Seat	8	323-39	2	Screw-HH 3/8-16 X 5
2	1-653282-03	2	Stop/Spacer-Seat	9	3296-39	2	Nut-Nyloc 3/8-16
3	109-9228	1	Kit,Seat Frame Service ●	10	103-5161	2	Link-Stop, Seat
4	26-4840	4	Spacer-Pin, Mounting	11	109-2759	2	Link-Stop, Seat
6	3296-29	6	Nut-Nyloc 5/16-18	12	322-5	6	Screw-HH 5/16-18 X 1
7	32128-20	4	Nut-Whizlock 5/16-18				

● Includes seat belt assembly

Seat W/Tracks Assembly No. 116-8912

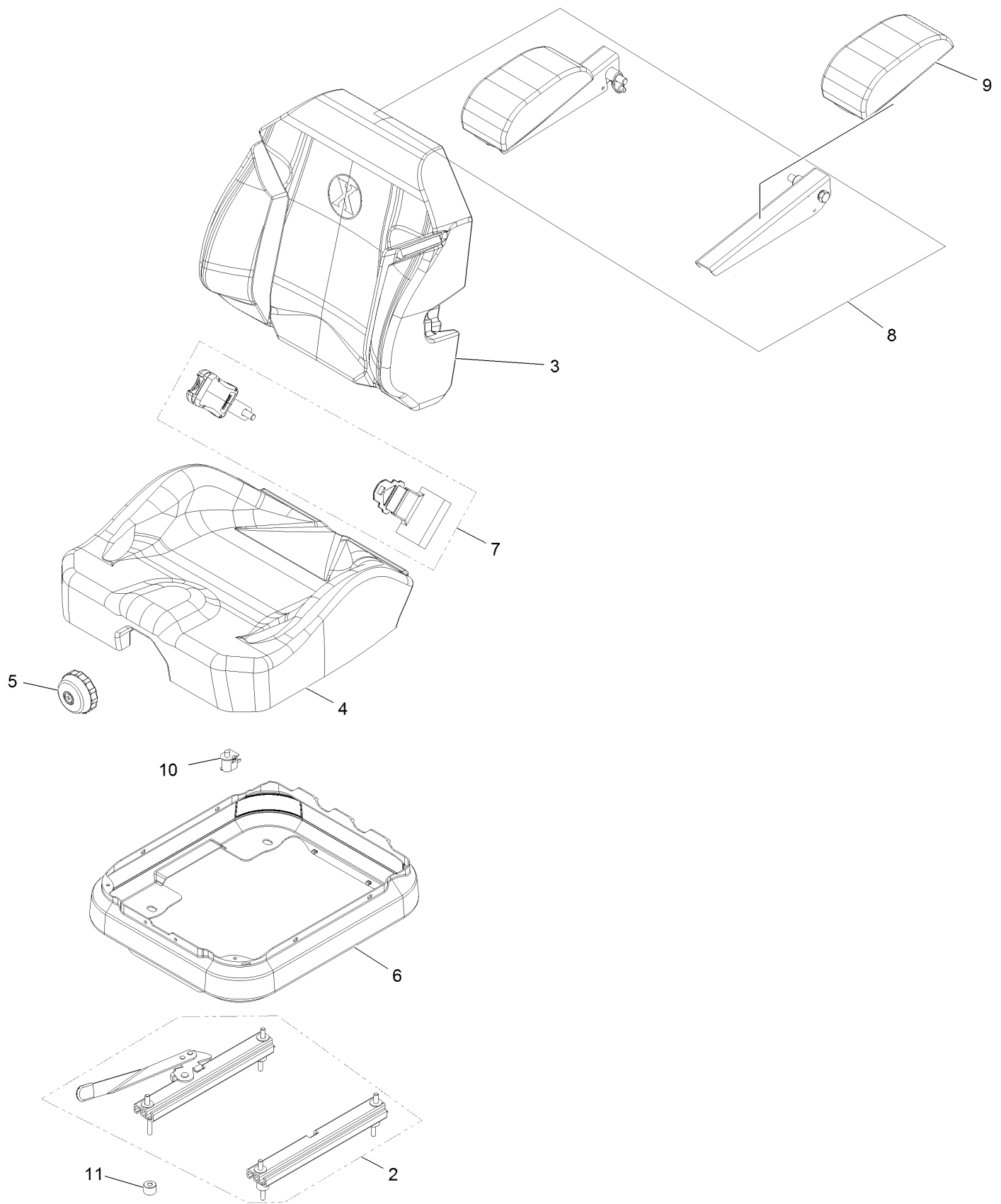

Seat W/Tracks Assembly No. 116-8912 (continued)

<i>Ref.</i>	<i>Part Number</i>	<i>Qty.</i>	<i>Description</i>
2	116-8910	1	Seat Track Set
3	116-8908	1	Cover-Back 311463Vn500
4	116-8909	1	Cover-Cushion 311464Vn500
5	116-8911	1	Knob-Adjuster
6	116-5659	1	Cover-Suspension Bellows

<i>Ref.</i>	<i>Part Number</i>	<i>Qty.</i>	<i>Description</i>
7	126-2061	1	Seat Belt Service Kit
8	116-8906	1	Kit-Arm Rest Set
9	116-8905	1	Kit-Arm Rest Pads
10	82-2190	1	Switch-Bail
11	116-9329	4	Spacer

Seat Frame Single Latch Assembly

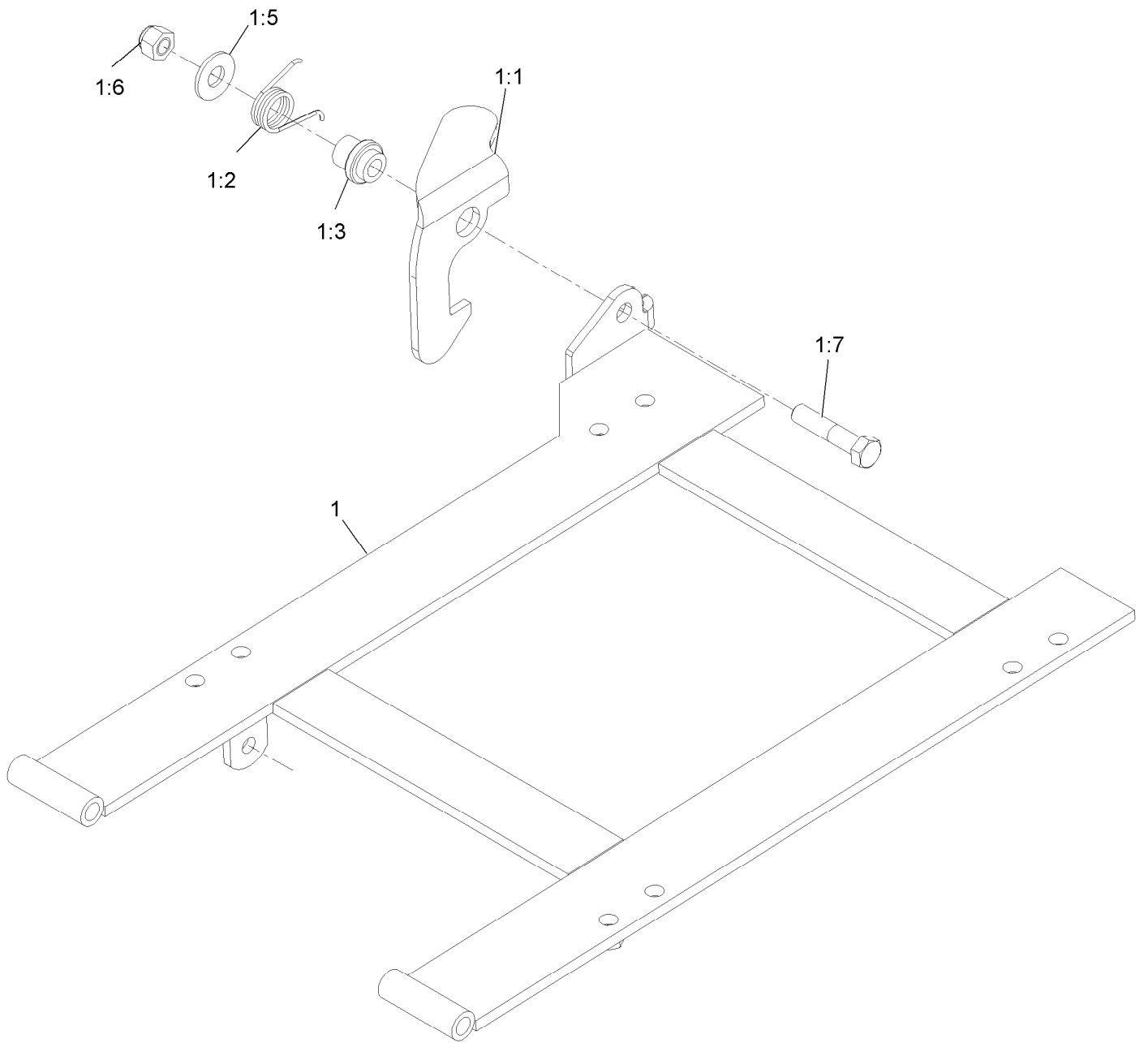

Seat Frame Single Latch Assembly (continued)

<i>Ref.</i>	<i>Part Number</i>	<i>Qty.</i>	<i>Description</i>	<i>Ref.</i>	<i>Part Number</i>	<i>Qty.</i>	<i>Description</i>
1		1	Seat Frame Single Latch ASM ●	1:3	107-0075	1	Bushing
1:1	103-5520	1	Catch-Latch, Single	1:5	3256-4	1	Washer-3/8 Std
1:2	103-5519	1	Spring-Torsion, Latch	1:6	3296-39	1	Nut-Nyloc 3/8-16
				1:7	323-9	1	Screw-HH 3/8-16 X 1 3/4

● Not serviced separately

Fuel Assembly (continued)

<i>Ref.</i>	<i>Part Number</i>	<i>Qty.</i>	<i>Description</i>	<i>Ref.</i>	<i>Part Number</i>	<i>Qty.</i>	<i>Description</i>
2	1-633349	6	Spring-Compression	28:3	114-5062	1	Cap-Biodiesel
3	1-643115	4	Tie-Cable 11.4	29	116-0142	1	ASM, Fuel Tank Lxs RH
4	1-643312	1	Clip-Loom	29:1	1-633023	3	Stud-Fuel Tank ▲
5	1-805005	4	Washer-Lock 5/16 Heavy	29:2	114-5062	1	Cap-Biodiesel
6	1-807513	2	Bolt-Carriage #10-24 X 1/2	31	321-3	1	Screw-HH 1/4-20 X 5/8
7	1-807533	1	Bolt-Carriage #10-24 X 5/8	32	321-8	1	Screw-HH 1/4-20 X 1 1/4
8	103-1193	1	Clip-Loom Half	33	322-3	4	Screw-HH 5/16-18 X 3/4
9	104-8300	2	Nut-Nyloc 5/16-18 Flg	34	322-4	3	Screw-HH 5/16-18 X 7/8
11	108-5928	1	Swivel-Stop, Cable	35	353-707	2	Adapter-90°
12	109-0274	1	Hose-Fuel Line 16"	36	2412-108	5	Clamp-Hose
14	109-6652	1	Cable, Throttle	38	3220-1	2	Nut-Jam 1/4-28
15	110-0047	1	Hose-Fuel Line 2 3/8"	39	3256-14	1	Washer-#10 Std
17	110-4104	1	Hose-Fuel Line 11"	40	3256-23	13	Washer-5/16 Sae
21	110-8806	1	Pump-Fuel	41	3296-2	3	Nut-Nyloc #10-24
22	110-8817	1	Bracket-Pump, Fuel	42	3296-47	6	Nut-Nyloc 5/16-18 Thin
24	112-7836	1	Filter-Inline	43	32128-20	1	Nut-Whizlock 5/16-18
26	116-0290	1	ASM,Fuel Filter	44	32128-33	2	Nut-Whizlock 1/4-20
26:2	116-0289	1	Filter,Fuel	45	92-2379	2	Clamp-Hose
26:3	116-1559	2	Decal,Exmark Filter	46	103-6564	1	Kit-Fuel Gauge
27		1	ASM, Fuel Valve-Hoses ●	47	116-0968	1	Fitting,Fuel Bulkhead W/O Screen ■
28	116-0141	1	ASM,Fuel Tank Lxs LH	48	103-2784	1	O-Ring
28:1	1-633023	3	Stud-Fuel Tank ▲				

● Not serviced separately

■ Use Pro-Lock, Nut Type (P/N 1-840022, .5ml tube) on threads.

▲ Use Pro-Lock retaining type, Part no. 1-840023 (.5cc tube) on threads.

Fuel Valve Hose Assembly

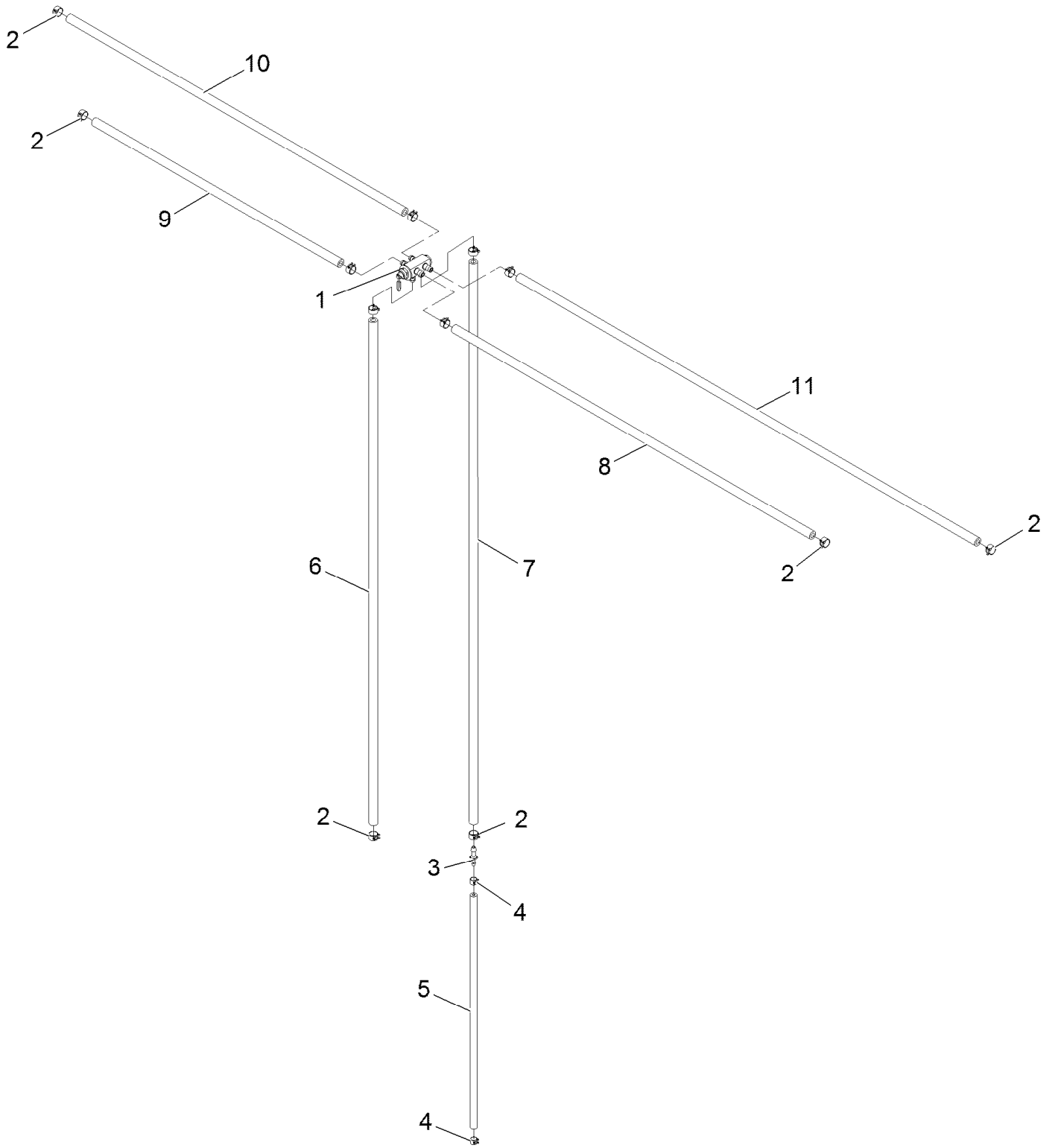

Fuel Valve Hose Assembly (continued)

<i>Ref.</i>	<i>Part Number</i>	<i>Qty.</i>	<i>Description</i>	<i>Ref.</i>	<i>Part Number</i>	<i>Qty.</i>	<i>Description</i>
1	116-0973	1	Valve,Fuel Selector 5/16	7	110-4100	1	Hose-Fuel
2	92-2379	12	Clamp-Hose	8	115-2370	1	Hose-Fuel
3	121-2573	1	Fitting-Straight	9	108-3284	1	Hose-Fuel
4	2412-80	2	Clamp-Hose	10	110-6186	1	Hose-Fuel
5	68-3633	1	Hose-Fuel	11	109-0277	1	Hose-Fuel
6	110-4114	1	Hose-Fuel				

Engine Assembly

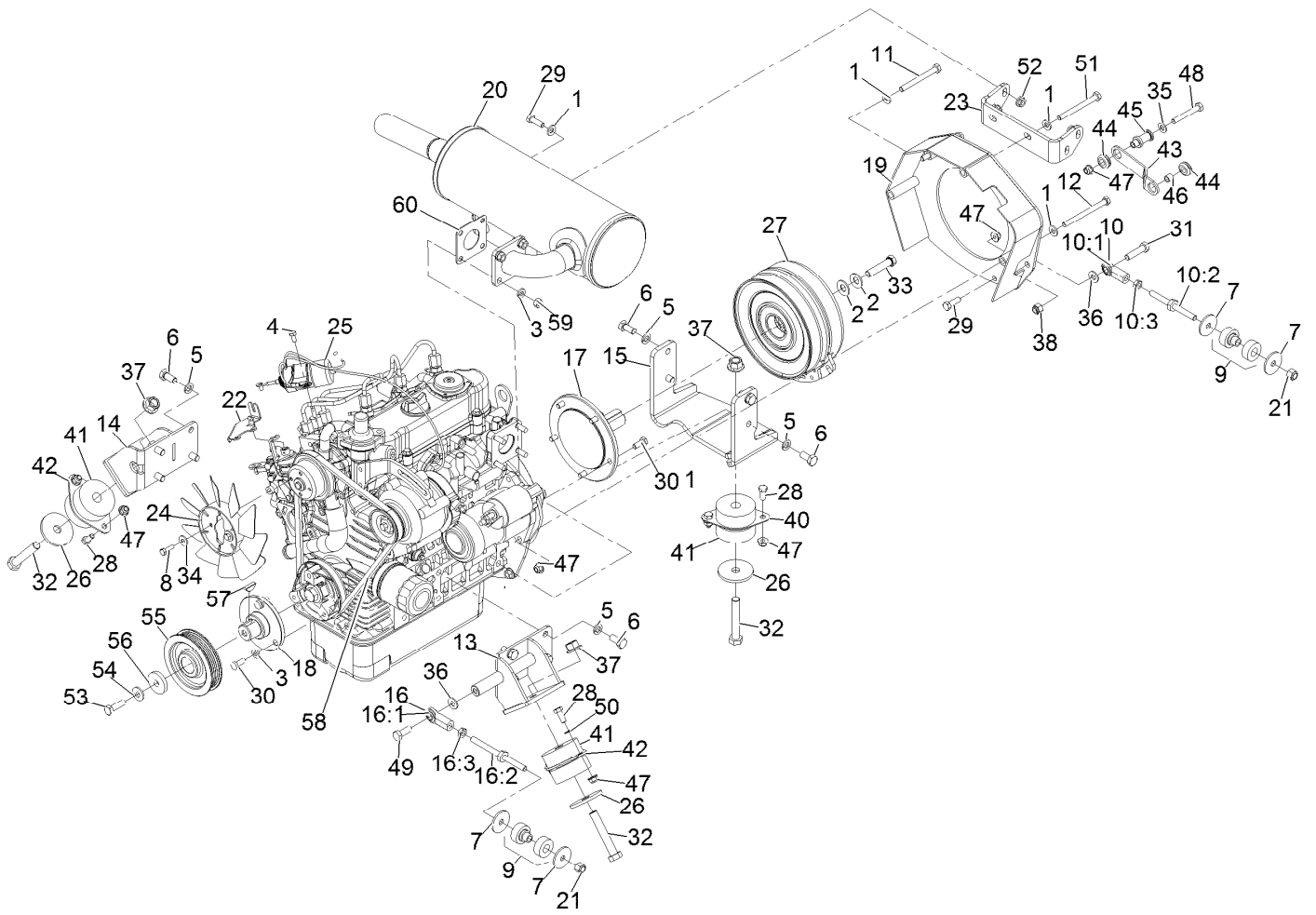

Engine Assembly (continued)

<i>Ref.</i>	<i>Part Number</i>	<i>Qty.</i>	<i>Description</i>	<i>Ref.</i>	<i>Part Number</i>	<i>Qty.</i>	<i>Description</i>
1	1-303334	8	Washer-Spring Disc 5/16	28	322-3	6	Screw-HH 5/16-18 X 3/4
2	1-603610	2	Washer-Spring Disc 7/16	29	322-5	5	Screw-HH 5/16-18 X 1
3	1-805005	7	Washer-Lock 5/16 Heavy	30	33114-020	8	Screw-HH M8-1.25 X 20Mm
4	33113-012	2	Screw-HH M6-1 X 12Mm	31	323-8	1	Screw-HH 3/8-16 X 1 1/2
5	42-9600	12	Washer-Lock M10	32	325-12	3	Screw-HH 1/2-13 X 3
6	63-7790	12	Screw-HH M10-1.25 X 1.25Mm	33	3212-8	1	Screw-HH 7/16-20 X 2 ●
7	93-6099	4	Washer	34	3256-2	2	Washer-1/4 Std
8	33113-020	2	Screw-HH M6-1 X 12Mm	35	3256-23	1	Washer-5/16 Sae
9	103-3568	2	Isolator-Link	36	3256-24	2	Washer-3/8 Sae
10	103-3745	1	Ball Joint Link ASM	37	99-5107	3	Nut-Lock 1/2-13
10:1	103-0608	1	Balljoint	38	3296-39	1	Nut-Nyloc 3/8-16
10:2	103-3567	1	Link, A-T	40	116-2641-03	1	Flange ASM
10:3	3220-3	1	Nut-Jam 3/8-24	41	116-4433	3	Isolator,Engine
11	33114-080	1	Screw-HH M8-1.25 X 80Mm	42	116-2725-03	2	Flange-11GA
12	322-23	1	Screw-HH 5/16-18 X 3 3/4	43	116-5296-03	1	Clutch Link
13	116-4514-03	1	Engine Mount-LH	44	1-633630	2	Grommet
14	116-4513-03	1	Engine Mount-RH	45	116-5295	1	Clutch Standoff
15	116-2638-03	1	Bracket,Engine Mount	46	1-633545	1	Spacer
16	109-8528	1	Asm, A-T Link	47	104-8300	9	Nut-Nyloc 5/16-18 Flg
16:1	103-0608	1	Balljoint	48	322-11	1	Screw-HH 5/16-18 X 2 1/4
16:2	103-7544	1	Link, Rear A-T Axial	49	3235-22	1	Screw-HH, Lock
16:3	3220-3	1	Nut-Jam 3/8-24	50	3255-8	1	Washer-Lock 5/16 (Ext-Tooth)
17	109-9873	1	Shaft,Kubota 902 Stub	51	119-4866	2	Screw-HH ●
18	103-7556	1	Hub, Pump Drive	52	32128-20	4	Nut-Whizlock 5/16-18
19	116-5089-03	1	Wld,Flywheel Cover	53	323-7	1	Screw-HH 3/8-16 X 1 1/4
20	116-7108	1	Muffler Kit - Kubota	54	98-5975	1	Washer-Spring Disc 3/8
21	3296-6	2	Nut-Nyloc 3/8-24	55	103-4718	1	Sheave, Engine
22	126-0723	1	Bracket, Kd Throttle	56	1-543610	1	Washer
23	116-6179-03	1	Support-Muffler	57	1-807014	1	Key-Woodruff 1/4 X 7/8
24	109-0789	1	Fan	58	109-2901	1	Belt
25	109-1211	1	Solenoid, Fuel.	59	33014-00	4	Nut-Hex M8-1.25
26	116-5142	3	Washer	60	99-8343	1	Gasket-Muffler
27	116-1610	1	Clutch, Cms250 Kd				

● Use Pro-Lock, Nut Type (P/N 1-840022, .5ml tube) on threads.

Cooling Assembly

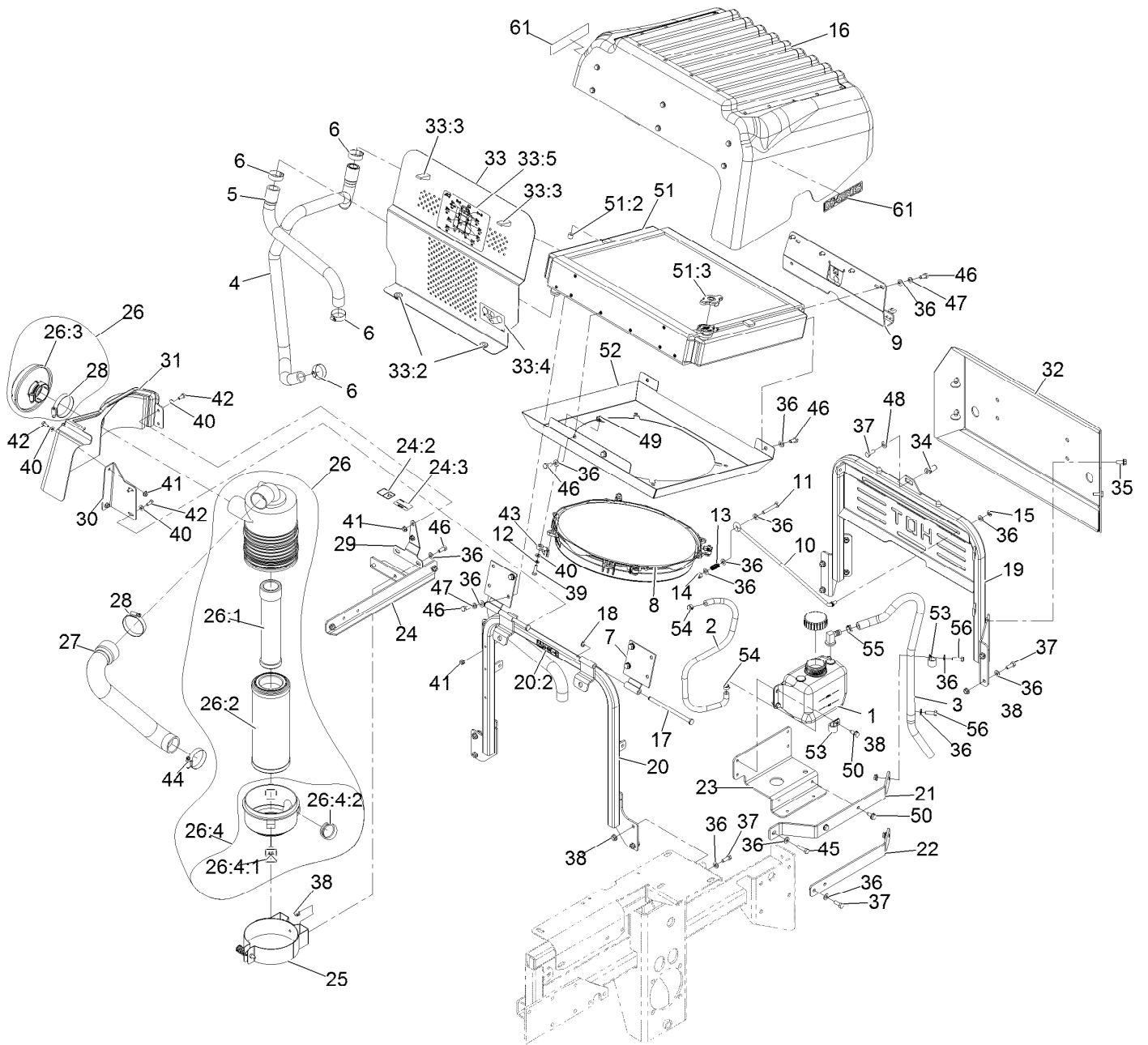

Cooling Assembly (continued)

<i>Ref.</i>	<i>Part Number</i>	<i>Qty.</i>	<i>Description</i>	<i>Ref.</i>	<i>Part Number</i>	<i>Qty.</i>	<i>Description</i>
1	116-7124	1	Tank, Overflow W/Cap	26:4:2	109-2820	1	Ejector-Air Cleaner
2	116-7204	1	Hose, .313 I.D.X 25.0 Reinforced Epdm	27	103-7597	1	Hose, Air Intake
3	116-7245	1	Hose, .500 I.D. X 30" Epdm	28	2412-42	1	Clamp-Hose
4	109-3142	1	Hose, Radiator	29	103-9222-03	1	Bracket, Rear Cover
5	103-7532	1	Hose, Radiator	30	103-9206-03	1	Bracket, Front Cover
6	2412-34	4	Clamp-Hose	31	103-9221	1	Panel, Side
7	109-3179-03	2	Wld, Hinge Plate	32	103-1479-03	1	Bumper, Rear
8	116-6274	1	Fan- Electric	33	116-0136	1	ASM,Panel W/ Decals Lxs Lc Kd
9	109-8427	1	ASM-Latch Plate	33:2	109-0023	2	Grommet
10	103-9207	1	Rod, Prop	33:3	74-5950	2	Latch
11	322-10	1	Screw-HH 5/16-18 X 2	33:4	126-4760	1	Decal-Belt Pump Routing
12	3253-3	4	Washer-Lock 1/4	33:5	126-4761	1	Decal-Service Aid
13	103-6643	1	Spring	34	109-8432	1	Pin, Latch
14	3296-29	1	Nut-Nyloc 5/16-18	35	3234-47	4	Screw-HH Flg 5/16-18 X 3/4
15	109-0917	1	Nut-Push 5/16	36	3256-23	32	Washer-5/16 Sae
16	116-6394	1	Hood ASM, D902	37	322-4	12	Screw-HH 5/16-18 X 7/8
17	103-9218	2	Pin, Cover Pivot	38	32128-20	16	Nut-Whizlock 5/16-18
18	32120-18	2	E-Ring	39	321-6	4	Screw-HH 1/4-20 X 1
19	109-8546-03	1	Wld, Rear Radiator Mount	40	3256-22	10	Washer-1/4 Sae
20	109-2804	1	Asm, Front Radiator Mount (103-7582-03) W/Decals	41	32128-33	6	Nut-Whizlock 1/4-20
20:2	119-0217	1	Decal-Danger	42	321-3	6	Screw-HH 1/4-20 X 5/8
21	103-7558-03	1	Rib, Top	43	109-2950	4	Mount, Fan
22	103-7579-03	1	Rib, Bottom	44	1-643009	1	Clamp-Hose
23	116-4822-03	1	Bracket, Bottle-Hydro Tank	45	322-6	1	Screw-HH 5/16-18 X 1 1/4
24	103-9248-03	1	Wld, Air Cleaner Mount	46	322-3	14	Screw-HH 5/16-18 X 3/4
24	109-3257	1	Asm, Air Cleaner Brkt W/Decals	47	3253-4	8	Washer-Lock 5/16
24:2	106-5517	1	Decal-Warning, Hot Surface	48	1-303334	1	Washer-Spring Disc 5/16
24:3	110-0806	1	Decal-Caution	49	107069	4	Nut-Retainer-Panel 1/4-20
25	103-1058	1	Bracket-Filter, Air	50	32144-70	6	Screw-HWH 5/16-18 X 3/4 Tf
26	103-5178	1	Asm-Canister Air Filter W/Hood	51	116-5303	1	Radiator ASM, AI D902
26:1	103-1326	1	Filter-Air, Safety	51:2	99-8551	1	Plug-Pipe
26:2	103-1327	1	Filter-Air	51:3	1-643161	1	Cap-Radiator
26:3	100-2436	1	Asm-Hood Air Intake W/Clamp	52	116-6296-03	1	Fan Shroud,16
26:4	103-1060	1	Cover-Filter, Air	53	1-633396	3	Clip-Loom 5/8
26:4:1	99-3174	2	Clip-Cleaner, Air	54	92-2379	2	Clamp-Hose
				55	110-6242	1	Clamp-Hose
				56	322-5	2	Screw-HH 5/16-18 X 1
				61	116-6992	2	Decal, Ds Series

Hood Assembly

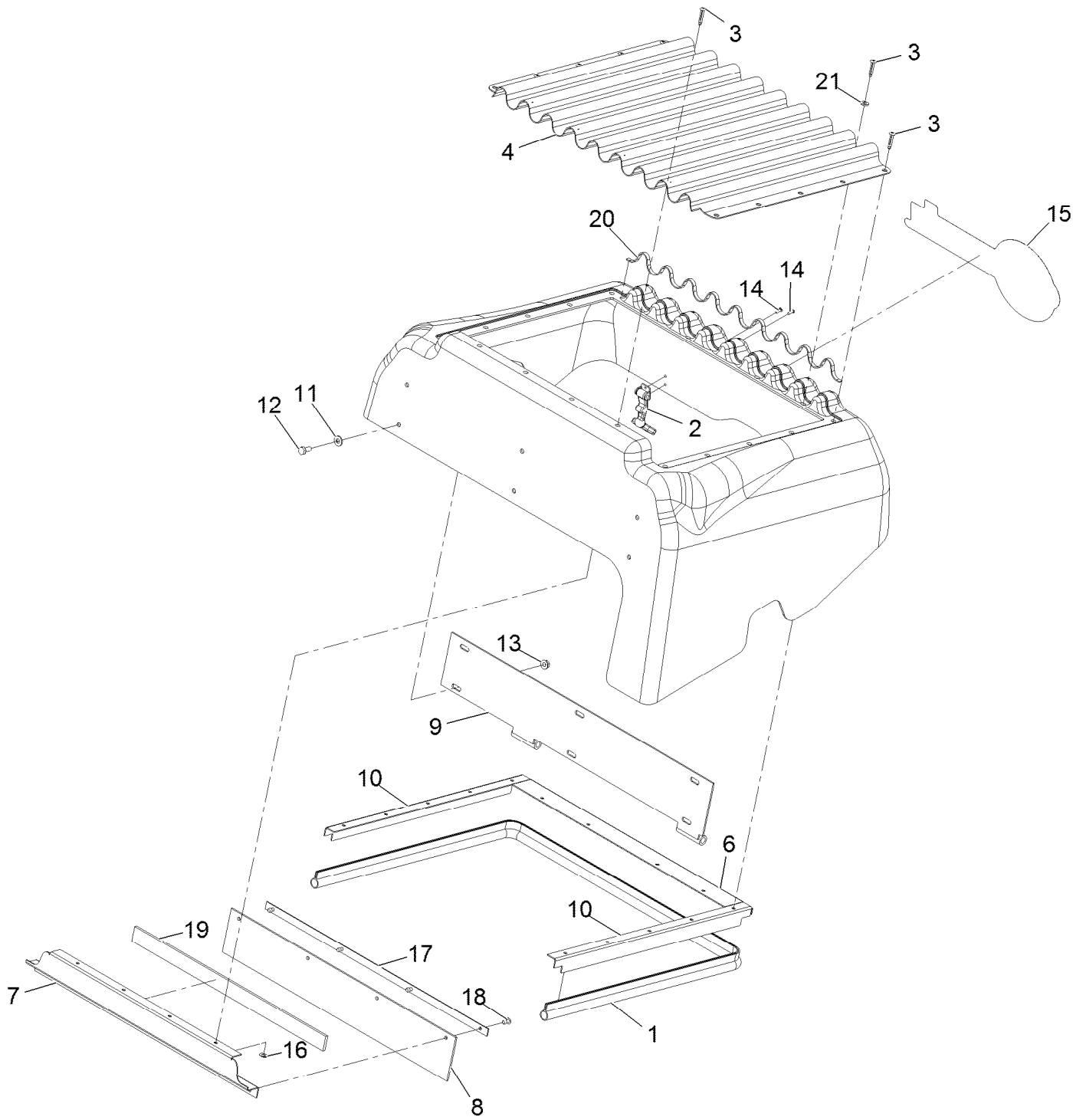

Hood Assembly (continued)

<i>Ref.</i>	<i>Part Number</i>	<i>Qty.</i>	<i>Description</i>	<i>Ref.</i>	<i>Part Number</i>	<i>Qty.</i>	<i>Description</i>
1	116-5325	1	Seal-Trim 54.6	12	321-3	6	Screw-HH 1/4-20 X 5/8
2	1-643188	2	Latch-Rubber	13	32128-33	6	Nut-Whizlock 1/4-20
3	1-803072	18	Rivet	14	923786	4	Rivet
4	103-9201-03	1	Screen, Radiator	15	109-1801	1	Decal, Exmark Logo
6	116-5323-03	1	Mount-Seal Rear	16	1-303435	4	Washer-Spring Disc 1/4
7	116-5302-03	1	Mount-Seal Front	17	116-5319-03	1	Plate-Seal Backup
8	116-5160	1	Seal-Radiator Hood	18	1-803073	4	Rivet-Pop
9	103-9226-03	1	Wld, Hinge	19	116-5348	1	Seal-Front Screen
10	116-5324-03	2	Mount-Seal Side	20	116-5349	1	Seal-Rear Screen
11	3256-22	6	Washer-1/4 Sae	21	3256-14	4	Washer-#10 Std

Latch Plate Assembly No. 109-8427

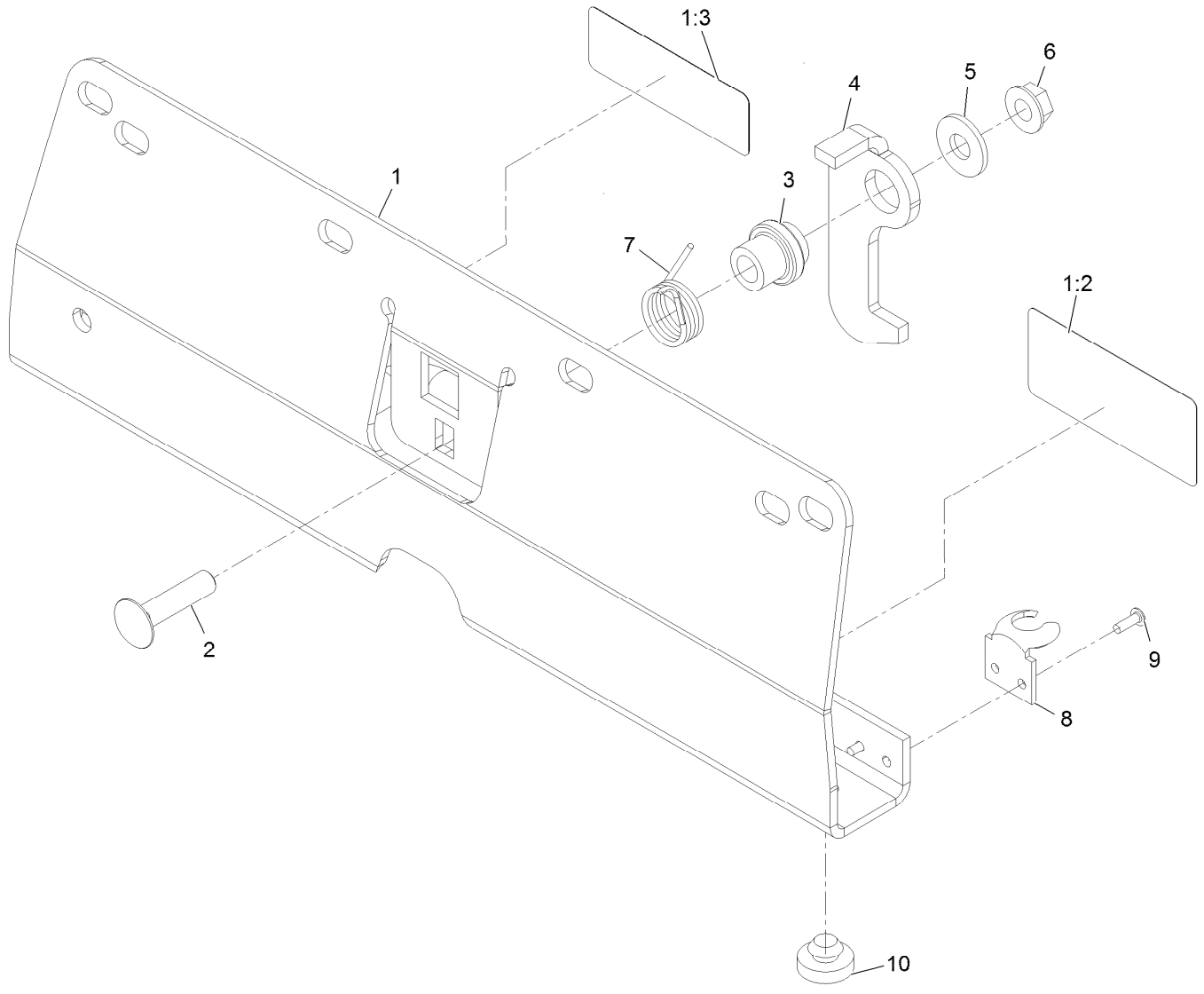

Latch Plate Assembly No. 109-8427 (continued)

<i>Ref.</i>	<i>Part Number</i>	<i>Qty.</i>	<i>Description</i>	<i>Ref.</i>	<i>Part Number</i>	<i>Qty.</i>	<i>Description</i>
1	109-8539	1	Asm, Latch Plate W/Decals	5	3256-3	1	Washer-5/16 Std
1:2	110-3842	1	Decal-Antifreeze	6	32128-25	1	Nut-Hex 5/16-18 Side Lock
1:3	120-0625	1	Decal-Warning, Pinch Point	7	109-8430	1	Spring
2	112-6950	1	Bolt-Carriage 5/16-18 X 1 3/8 Short Neck	8	249-40	2	Keeper
3	107-0075	1	Bushing	9	923786	4	Rivet
4	109-8431	1	Hook, Latch	10	1-513658	2	Bumper

Mule Drive Assembly

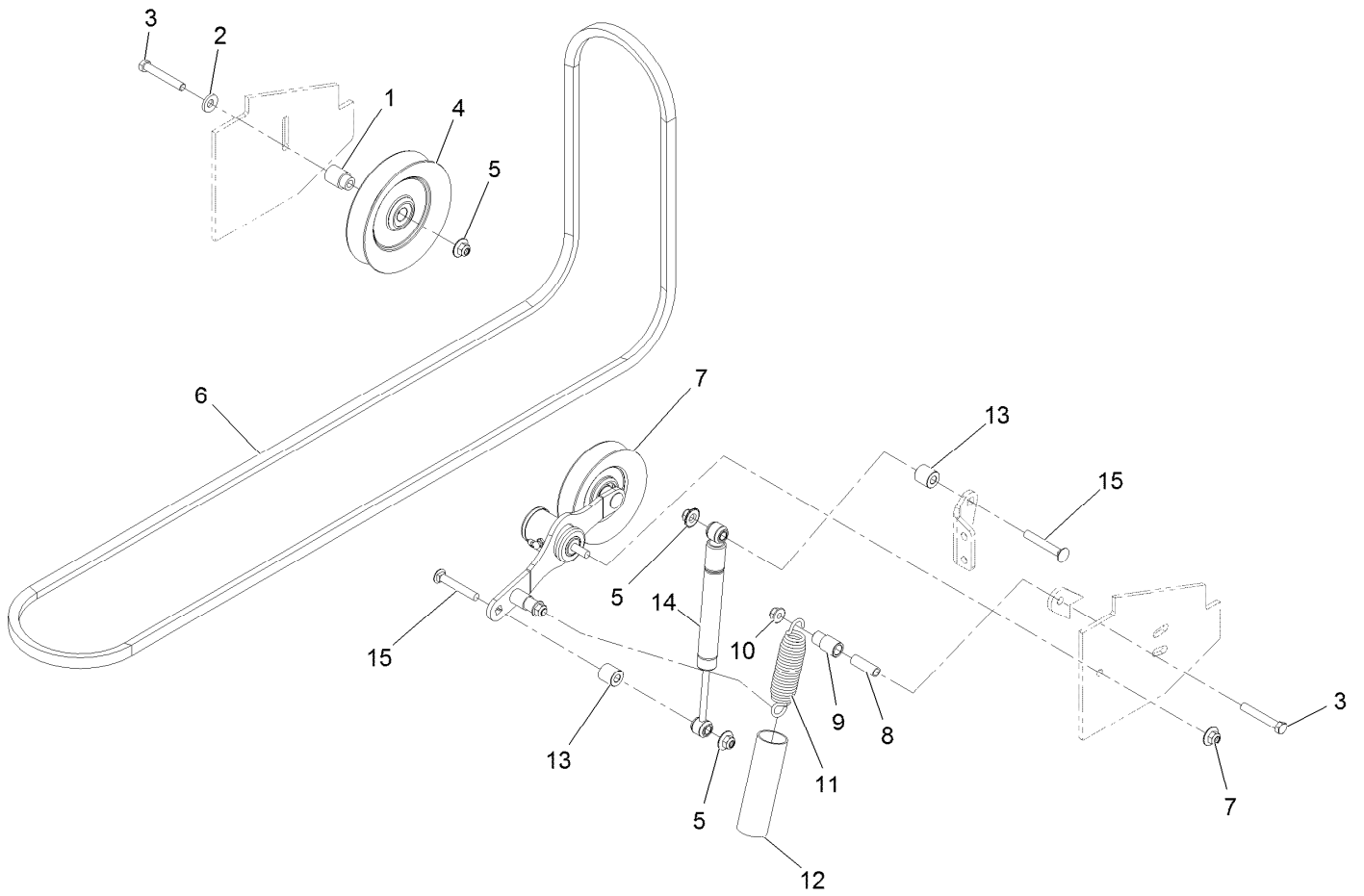

Mule Drive Assembly (continued)

<i>Ref.</i>	<i>Part Number</i>	<i>Qty.</i>	<i>Description</i>	<i>Ref.</i>	<i>Part Number</i>	<i>Qty.</i>	<i>Description</i>
1	103-2627	1	Bushing-Idler	9	109-8866	1	Bushing, Plastic
2	98-5975	1	Washer-Spring Disc 3/8	10	104-8301	1	Nut-Nyloc 3/8-16 Flg
3	323-12	2	Screw-HH 3/8-16 X 2 1/2	11	116-6316	1	Spring-Extension
4	1-633166	1	Pulley-Idler	12	116-0932	1	Dampener, Spring
5	109-6658	3	Nut-Nyloc 3/8-16 Flg	13	116-9300	2	Spacer-.39Idx.88Odx.88L
6	109-4199	1	Belt, Mule Drive	14	116-9280	1	Damper-Mule Belt Drive
7	116-9286	1	ASM-Ttnr Arm W/Pulley	15	3231-31	2	Bolt-Carriage 3/8-16 X 2 1/2
8	109-8754	1	Spacer				

Tightener Arm W/Pulley Assembly No. 116-9286

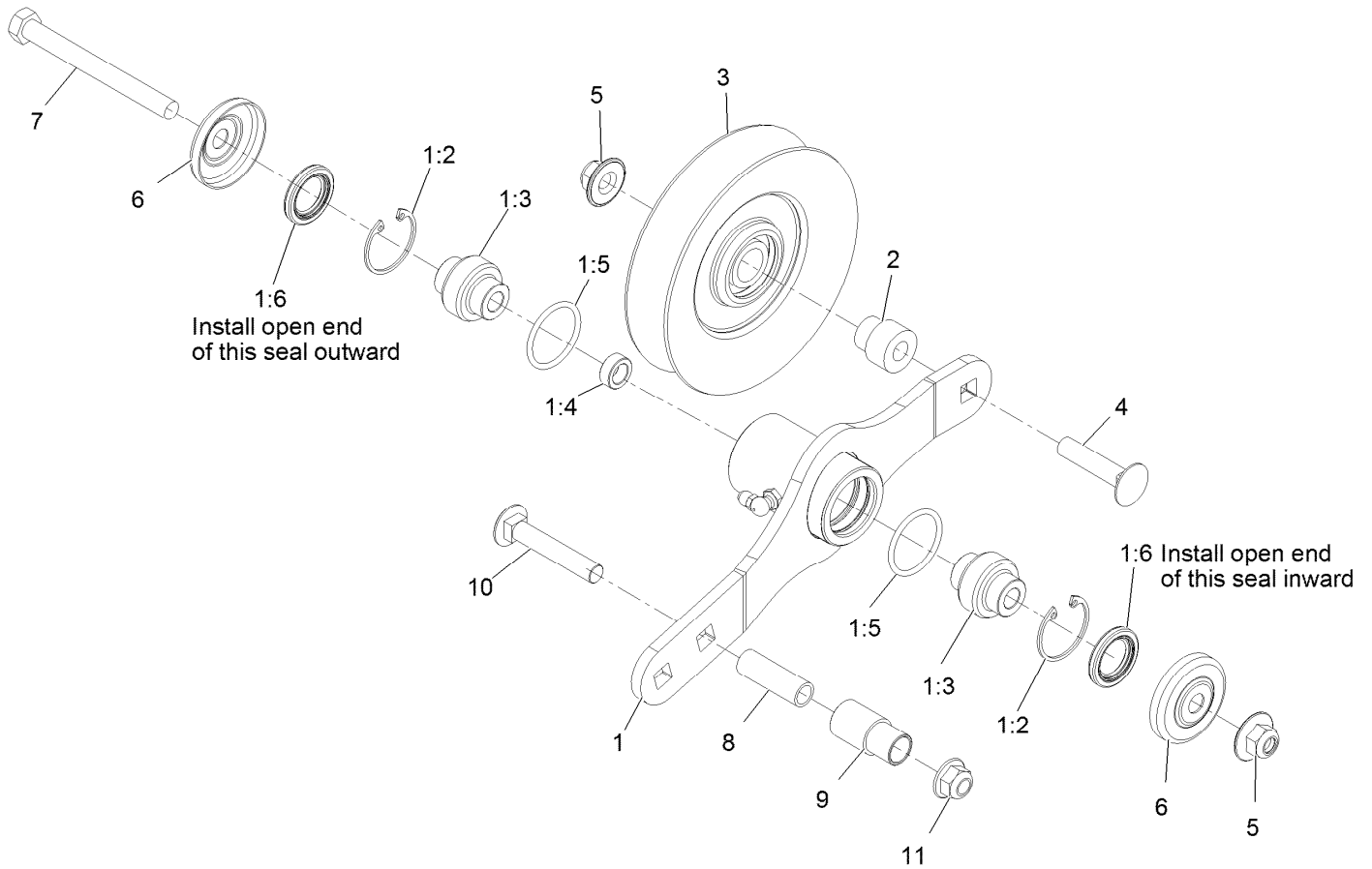

Tightener Arm W/Pulley Assembly No. 116-9286 (continued)

<i>Ref.</i>	<i>Part Number</i>	<i>Qty.</i>	<i>Description</i>	<i>Ref.</i>	<i>Part Number</i>	<i>Qty.</i>	<i>Description</i>
1		1	ASM-Ttnr Arm W/Bearings ●	4	3231-5	1	Bolt-Carriage 3/8-16 X 1 3/4
1:2	32120-10	2	Ring-Retaining	5	109-6658	2	Nut-Nyloc 3/8-16 Flg
1:3	103-3504	2	Bearing-Spherical	6	103-2916	2	Guard-Top
1:4	103-5677	1	Spacer	7	323-42	1	Screw-HH 3/8-16 X 3 3/4
1:5	106-7159	2	O-Ring	8	109-8754	1	Spacer
1:6	103-3506	2	Seal-Single Lip	9	109-8866	1	Bushing, Plastic
2	1-603496	1	Bushing-Idler	10	3231-7	1	Bolt-Carriage 3/8-16 X 2 1/4
3	1-603805	1	Pulley-Idler	11	104-8301	1	Nut-Nyloc 3/8-16 Flg

● Not serviced separately

Hydraulic Assembly

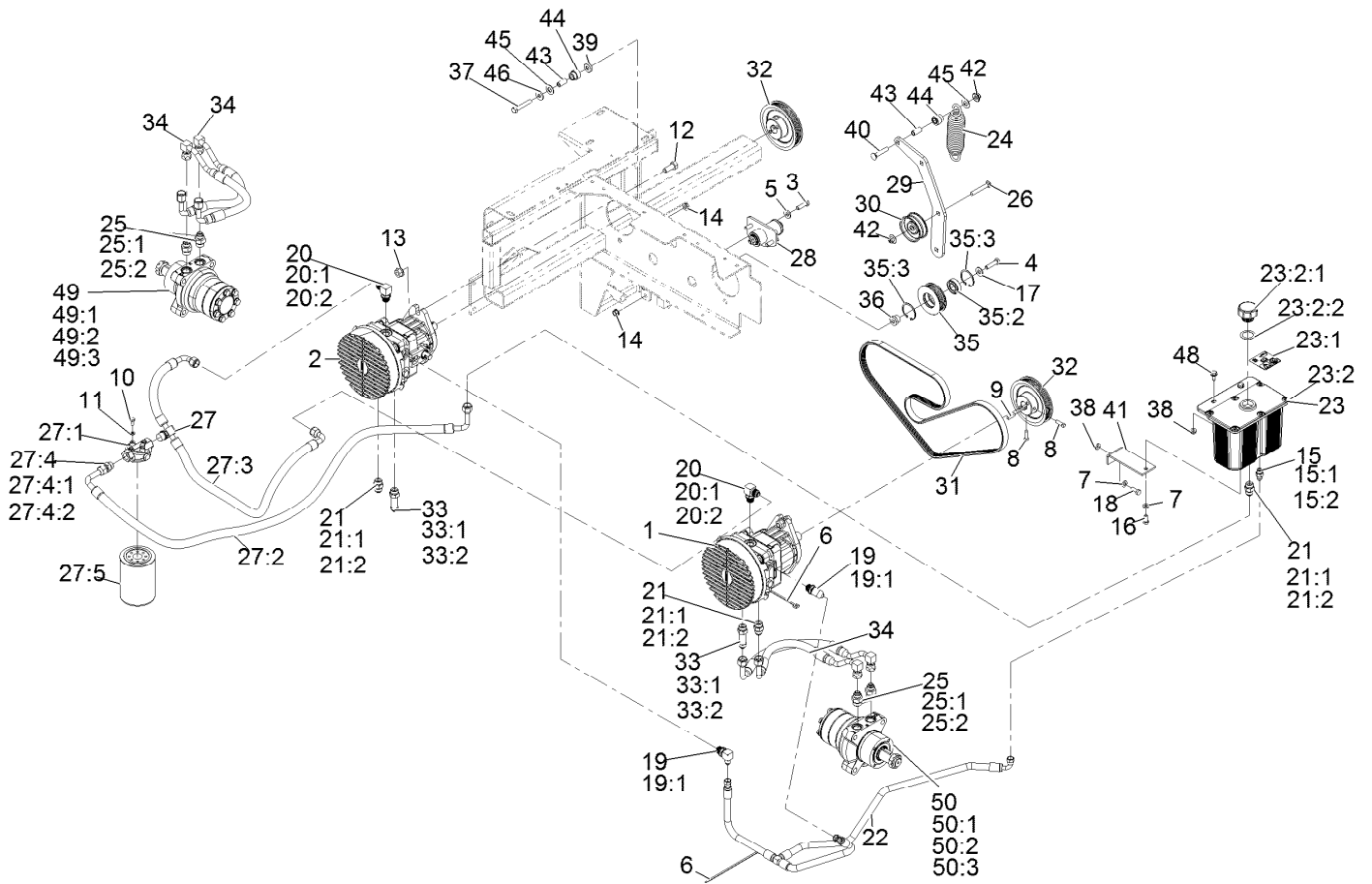

Hydraulic Assembly (continued)

<i>Ref.</i>	<i>Part Number</i>	<i>Qty.</i>	<i>Description</i>	<i>Ref.</i>	<i>Part Number</i>	<i>Qty.</i>	<i>Description</i>
1	109-7543	1	Pump, Hydro	27:2	109-6904	1	Asm, Filter Inlet Hose
2	109-7544	1	Pump, Hydro	27:3	109-6903	1	Hose, Pump Inlet
3	323-7	3	Screw-HH 3/8-16 X 1 1/4	27:4	1-603990	1	Adapter-Straight
4	323-8	1	Screw-HH 3/8-16 X 1 1/2	27:4:1	1-603920	1	O-Ring-Sae #8
5	98-5975	3	Washer-Spring Disc 3/8	27:4:2	1-603992	1	O-Ring-37 Flare #8
6	1-303335	2	Tie-Cable 7 15/16 (Large)	27:5	103-2146	1	Element-Hydraulic Oil Filter
7	3256-23	2	Washer-5/16 Sae	28	109-3250	1	Asm, Pump Idler W/Bearings
8	30-1710	4	Setscrew-5/16-18 X 1	29	103-7569-03	1	Arm, Pump Idler
9	1-807259	2	Key-Machine 1/4 X 1/4 X 1	30	116-0888	1	Idler, Flanged
10	321-3	2	Screw-HH 1/4-20 X 5/8	31	109-7582	1	Belt, Hydro Pump Drive
11	1-805004	2	Washer-Lock 1/4 Heavy	32	109-7561	2	Sheave, Hydro Pump
12	325-5	4	Screw-HH 1/2-13 X 1 1/4	33	103-1940	2	Adapter-Straight
13	32128-49	4	Nut-Whizlock 1/2-13	33:1	237-79	1	O-Ring
14	3290-357	4	Nut-Whizlock 3/8-16	33:2	1-603992	1	O-Ring-37 Flare #8
15	103-2156	1	Adapter-Straight	34	103-4679	4	HYD Hose ASM
15:1	1-603921	1	O-Ring-Sae #6	35	103-4728	1	Asm, Lower Frame Idler
15:2	103-1020	1	O-Ring-37 Flare #6	35:2	251-347	1	Bearing-Ball Deep Groove
16	322-3	1	Screw-HH 5/16-18 X 3/4	35:3	32151-13	2	Ring-Retaining
17	3256-4	1	Washer-3/8 Std	36	103-4566	1	Spacer, Lower Frame Idler
18	322-4	1	Screw-HH 5/16-18 X 7/8	37	323-11	1	Screw-HH 3/8-16 X 2 1/4
19	103-1014	2	Elbow-90°	38	32128-20	3	Nut-Whizlock 5/16-18
19:1	1-603920	1	O-Ring-Sae #8	39	103-3186	1	Spacer-Bracket, Guide
20	103-2153	2	Elbow-90°	40	3231-6	1	Bolt-Carriage 3/8-16 X 2
20:1	1-603920	1	O-Ring-Sae #8	41	109-0089-03	1	Bracket, Hydraulic Tank
20:2	1-603992	1	O-Ring-37 Flare #8	42	109-6658	2	Nut-Nyloc 3/8-16 Flg
21	1-603990	3	Adapter-Straight	43	109-8753	2	Spacer
21:1	1-603920	1	O-Ring-Sae #8	44	109-8752	2	Spacer
21:2	1-603992	1	O-Ring-37 Flare #8	45	112-9771	2	Washer-Teflon
22	109-0087	1	Asm-Case Drain Hose	46	5-0838	1	Washer
23	109-0582	1	Hydraulic Tank ASM	48	32144-70	2	Screw-HWH 5/16-18 X 3/4 Tf
23:1	115-4212	1	Decal-Warning	49	112-8358	1	HYD Motor ASM (CW)
23:2		1	Tank-Hydraulic ●	49:1	3257-42	1	Key-Woodruff 5/16 X 1
23:2:1	103-1948	1	Cap-Reservoir, HYD	49:2	1-809036	1	Nut-Slotted 1-20
23:2:2	103-1949	1	Gasket-Cap	49:3	109-5966	1	Wheel Motor Seal Kit
24	116-6317	1	Spring-Extension	50	112-8357	1	HYD Motor ASM (CCW)
25	1-603991	4	Adapter-Straight	50:1	3257-42	1	Key-Woodruff 5/16 X 1
25:1	237-80	1	O-Ring	50:2	1-809036	1	Nut-Slotted 1-20
25:2	1-603992	1	O-Ring-37 Flare #8	50:3	109-5966	1	Wheel Motor Seal Kit
26	3231-31	1	Bolt-Carriage 3/8-16 X 2 1/2				
27	109-6905	1	Asm, Charge Hose				
27:1	103-2259	1	Head-Filter				

● Not serviced separately

Electrical Assembly

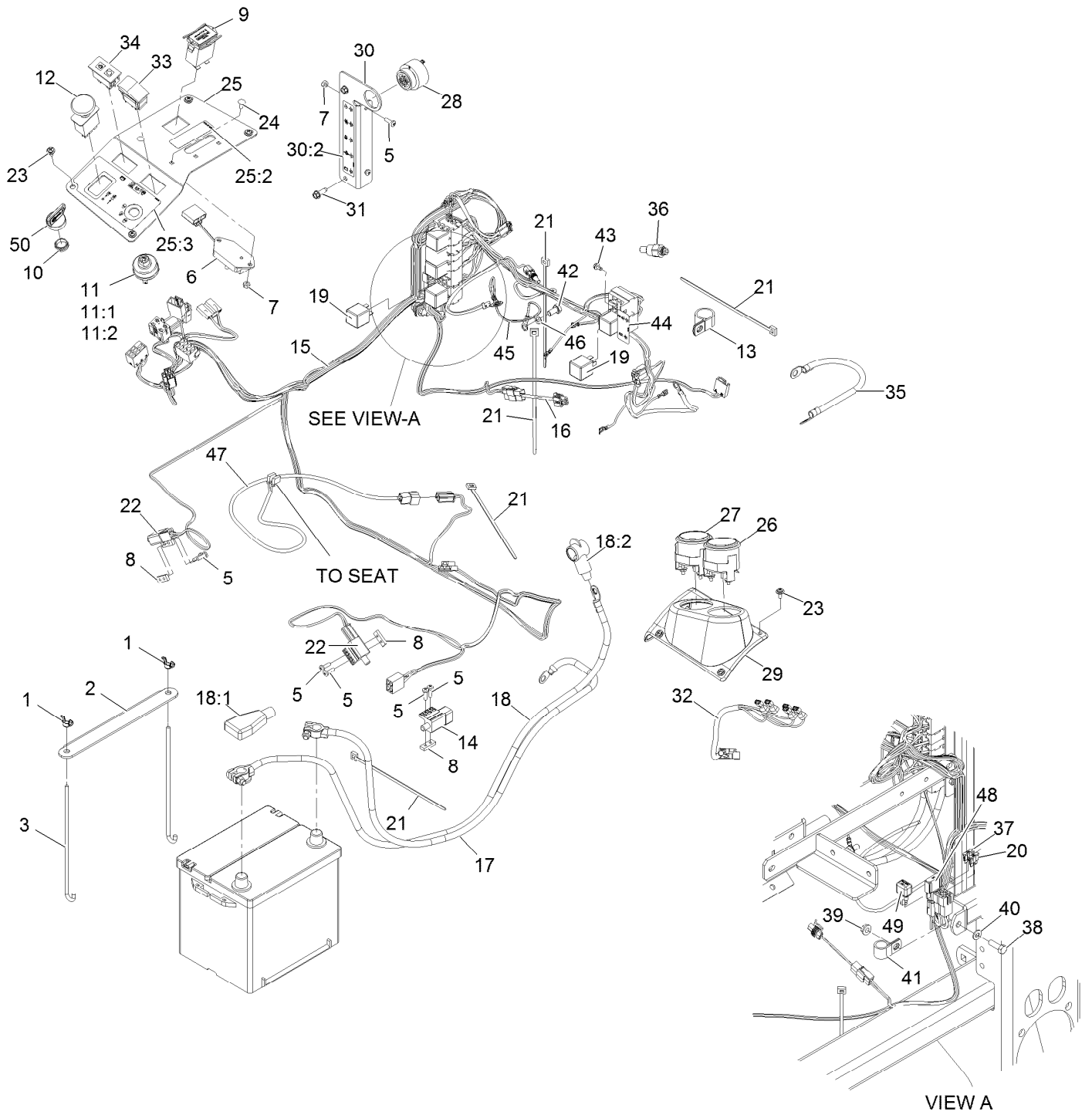

Electrical Assembly (continued)

<i>Ref.</i>	<i>Part Number</i>	<i>Qty.</i>	<i>Description</i>	<i>Ref.</i>	<i>Part Number</i>	<i>Qty.</i>	<i>Description</i>
1	1-543792	2	Wingnut-Nyloc 1/4-20	25:2	106-2733	1	Decal-Throttle
2	103-1311-03	1	Holddown-Battery	25:3	126-4763	1	Decal-Control Panel
3	103-1312	2	Bolt-Holddown	26	1-643021	1	Gauge-Temperature
5	3290-500	8	Screw-PPH #10-24 X 5/8	27	1-643037	1	Gauge-Voltmeter
6	103-5218	1	Module-Delay, Seat	28	103-0205	1	Alarm-Dual Tone 12Vdc
7	3296-2	4	Nut-Nyloc #10-24	29	103-3684	1	Bezel, Gauge
8	1-633181	3	Plate-Tapped	30	109-3495	1	Asm, Relay Mount Bracket
9	1-513374	1	Meter-Engine Hours	30:2	126-4759	1	Decal-Relay
10	103-0498	1	Nut-Ignition	31	49-2040	2	Screw-HWH 1/4-20 X 3/4 Tf
11	103-0206	1	Switch-Ignition W/Keys	32	103-4339	1	Harness-Gauge ▲
11:1	3254-5	1	Washer-Tooth, Internal	33	110-0811	1	Switch-Rocker
11:2	218-461	1	Nut-HH	34	109-2488	1	Cluster, Lights
12	114-0279	1	Switch-PTO	35	103-1349	1	Cable-Engine Negative
13	1-643312	1	Clip-Loom	36	103-7886	1	Sender, Temperature ■
14	1-633111	1	Switch	37	103-1368	1	Fuse-40 Amp
15	116-8236	1	Harness,Wiring-Lzds Kubota ▲	38	322-5	1	Screw-HH 5/16-18 X 1
16	110-8808	1	Harness-Wire	39	32128-20	1	Nut-Whizlock 5/16-18
17	109-3074	1	Cable, Ground (-)	40	3256-23	1	Washer-5/16 Sae
18	109-7607	1	Asm, Cable-Battery (+) ●	41	1-633396	1	Clip-Loom 5/8
18:1	103-1340	1	Insulator-Terminal, Battery	42	33114-016	1	Screw-HH M8-1.25 X 16Mm
18:2	103-1420	1	Insulator-Starter	43	104-2065	2	Screw-HWH #10-24 X 3/8
19	1-643275	7	Relay-12Vdc 40 Amp	44	126-4762	1	Decal-PTO Relay
20	1-816001	1	Fuse-Blade Type, 20 Amp	45	116-5163	1	Ground Wire ASM
21	1-303335	5	Tie-Cable 7 15/16 (Large)	46	3255-8	1	Washer-Lock 5/16 (Ext-Tooth)
22	1-513051	2	Switch-N.O.	47	103-1227	1	Harness-Wiring, Seat ▲
23	109-2661	8	Screw-PPH #10-24 X 1/2	48	94-8002	1	Fuse-Blade, 50 Amp
24	1-807513	2	Bolt-Carriage #10-24 X 1/2	49	100-4918	1	Diode-Over Molded
25	116-5139	1	Control Panel W/Decals	50	103-2106	1	Key-Exmark Logo

● Includes insulators

■ Use a Teflon Pipe Sealant or equivalent on threads.

▲ Use dielectric grease on all unsealed connectors and terminals only. Do not apply in sealed connectors.

Notes:

Notes:

Notes:

EXMARK® MAINTENANCE

MAXIMIZE THE PERFORMANCE OF YOUR EXMARK.

4-CYCLE PREMIUM ENGINE OIL

Part No. 116-3373

Both SAE 30 and SAE 10W-30 in one bottle.

Contains increased levels of zinc and phosphorus for better lubricity.

No Viscosity Index Improvers that tend to shear down in high heat.

Synthetic formulation.

Gas & Diesel compatible.

Anti-corrosion additives.

API 'SL' and JASO rated with wet clutch compatibility for other machines.

PREMIUM HYDRO OIL

Part No. 109-9828

Commercial quality for tough, high-heat conditions.

Designed specifically for zero-turn mower hydraulic systems.

Superior shear resistance under heavy loads.

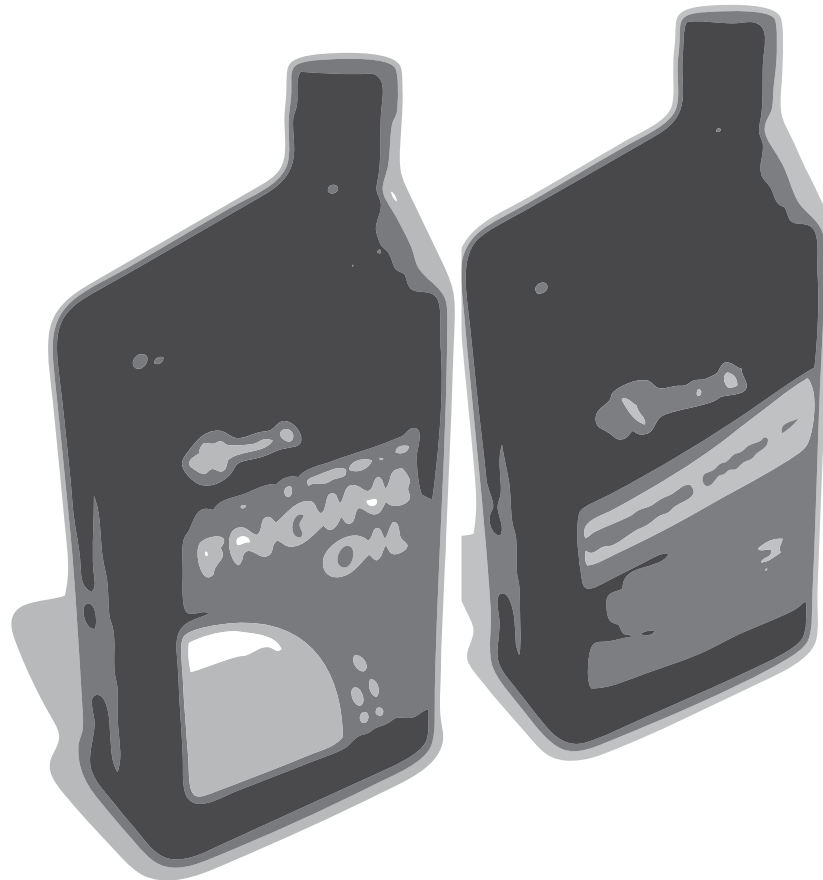

Available from your local Exmark dealer. Find your closest dealer at exmark.com

EXMARK ACCESSORIES AND OPTIONS*

MID-MOUNT RIDING ACCESSORIES AND OPTIONS

CUSTOM RIDE SEAT SUSPENSION SYSTEM	OPERATOR CONTROLLED DISCHARGE
FULL SUSPENSION SEAT	SUN SHADE
DECK LIFT ASSIST KIT	TRASH CONTAINER
HITCH KIT	TURF STRIPER
LIGHT KIT	ULTRA VAC COLLECTION SYSTEM
12V POWER PORT	ULTRA VAC QUICK DISPOSAL SYSTEM
MICRO-MULCH SYSTEM	

OUT-FRONT RIDING ACCESSORIES AND OPTIONS

CUSTOM RIDE SEAT SUSPENSION SYSTEM	SNOW BLADE
DUAL-TAIL WHEEL	SNOWBLOWER
FLOOR PAN EXTENDER	SUN SHADE
HITCH KIT	TRASH CONTAINER
LIGHT KIT	ULTRA VAC COLLECTION SYSTEM
MICRO-MULCH SYSTEM	ULTRA VAC QUICK DISPOSAL SYSTEM
ROLL OVER PROTECTION SYSTEM (ROPS)	WEATHER CAB

WALK-BEHIND ACCESSORIES AND OPTIONS

GRASS CATCHER	TURF STRIPER
MICRO-MULCH SYSTEM	STANDON

*Some accessories and options not available for some models.

Place Model No. and Serial No.
Label Here (Included in the Literature
Pack) or Fill in Below

Model No. _____

Serial No. _____

Date Purchased _____

Engine Model No. and Spec. No. _____

Engine Serial No. (E/No) _____

© 2015 Exmark Mfg. Co., Inc.
Industrial Park Box 808
Beatrice, NE 68310
All Rights Reserved

Part No. 4502-107 Rev. A
(402) 223-6300
Fax (402) 223-5489
Printed in the USA.

