

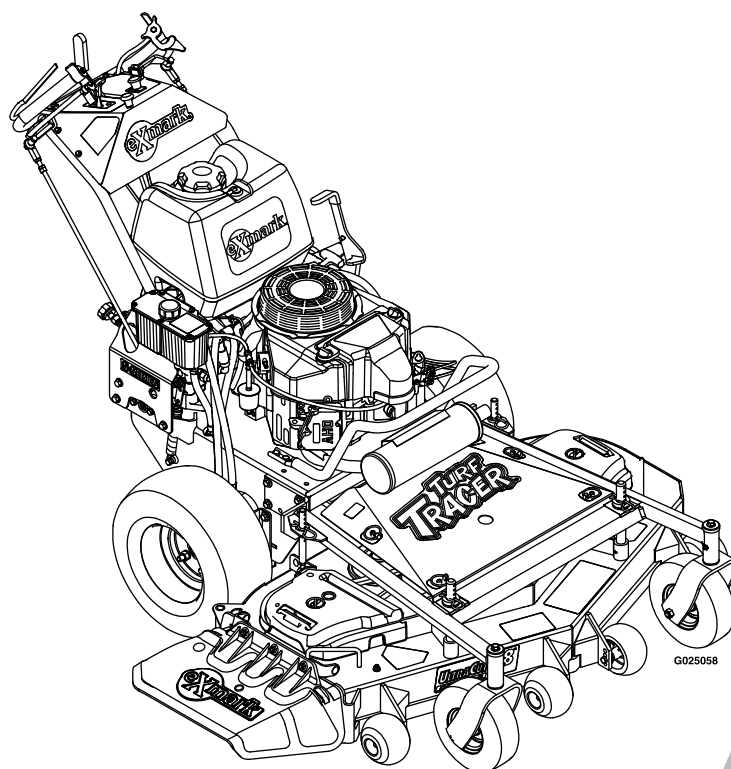

# TURF TRACER S-SERIES

Model No. TTS481CKA36300—Serial No. 31500000 and Up

Picture below may not reflect actual product.



# Parts Manual

Part No. 4501-942 Rev. B

# Ordering Replacement Parts

To order replacement parts, please supply the part number, the quantity, and the description of each part desired.

## Understanding Reference Numbers

Each identified part in an illustration has a reference number. The reference number for a part also appears in the parts list, along with other information about the part.

This catalog uses two special reference number formats, one to indicate parts in a service assembly and another to indicate the quantity of a given part in an illustration.

## Service Assembly Reference Numbers

Parts in service assemblies have reference numbers in the form a:b. The a represents the reference number of the entire service assembly and the b represents a sequential number unique to each part within the service assembly.

For example, a wheel assembly might be identified by reference number 6, the tire by 6:1, the valve by 6:2, and the wheel by 6:3. When you order the assembly identified by reference number 6, you receive all parts identified by reference numbers 6:1, 6:2, and 6:3. However, you may also order any part individually. Reference numbers of this type appear in illustration and in parts lists.

## Reference Numbers Indicating Quantity

In an illustration, if a reference number indicates more than one part, the reference number has the form nX y. The n represents the quantity of the part, the X is the multiplication symbol, and the y represents the reference number.

For example, in an illustration, the reference number 2X 37 means that two of the parts identified by reference number 37 are indicated.

# List of Abbreviations

<b>AR:</b> as required	<b>HLH:</b> hex lag head	<b>PTH:</b> phillips truss head
<b>ASM:</b> assembly	<b>HOC:</b> height-of-cut	<b>PTO:</b> power-take-off
<b>BBC:</b> blade brake control	<b>HP:</b> high pressure	<b>RH:</b> right hand
<b>BHTF:</b> button head thread forming	<b>HSBH:</b> hex socket button head	<b>ROPS:</b> roll-over protection system
<b>CARR:</b> carriage	<b>HSFH:</b> hex socket flat head	<b>RRB:</b> rear roller brush
<b>CCW:</b> counter clockwise	<b>HSH:</b> hex socket head	<b>SFH:</b> slotted fillister head
<b>CW:</b> clockwise	<b>HWH:</b> hex washer head	<b>SHH:</b> slotted hex head
<b>DEG:</b> degrees	<b>HWHTF:</b> hex washer head thread forming	<b>SHWH:</b> slotted hex washer head
<b>DPA:</b> Dual Point Adjustment	<b>HYD:</b> hydraulic	<b>SPH:</b> slotted pan head
<b>ECM:</b> electronic control module	<b>LH:</b> left hand	<b>SQH:</b> square head
<b>EXT:</b> external	<b>LP:</b> low pressure	<b>SRH:</b> slotted round head
<b>FH:</b> flat head	<b>LPG:</b> Liquefied Petroleum Gas	<b>STD:</b> standard
<b>GA:</b> gauge	<b>NI:</b> nylon insert	<b>TAP:</b> self tapping
<b>HD:</b> heavy-duty	<b>NPTF:</b> national pipe thread fine	<b>TTH:</b> torx truss head
<b>HF:</b> hex flange	<b>PFH:</b> phillips flat head	
<b>HH:</b> hex head	<b>PPH:</b> phillips pan head	
<b>HHF:</b> hex head flange	<b>PPHTF:</b> phillips pan head thread forming	
<b>HHFTF:</b> hex head flange thread forming	<b>PRH:</b> phillips round head	
<b>HJ:</b> hex jam		

# Touch Up Paint

Exmark black touch up spray paint – gloss black.

Exmark red touch up paint (spray paint – P/N 1-850337 - .6 oz liquid bottle – P/N 103-9140).



If your Exmark dealer does not have the Exmark part in stock, Exmark will get the parts to the dealer the next business day or the part will be FREE Guaranteed!! (Some restrictions apply. See your participating Exmark Dealer for details.)

## Contents

Complete Deck Assembly.....	4
Deck Assembly.....	5
Deck W/Decals Assembly No. 126-0634.....	7
Deck Idler Assembly No. 126-2204.....	8
Main Frame Assembly.....	9
Engine Deck.....	10
Handle Assembly.....	12
Controls Assembly.....	14
Fuel Tank Assembly.....	15
Engine Assembly.....	16
Ground Drive Assembly.....	17
Pump Idler Assembly No. 126-0615.....	19
Electrical Assembly.....	20

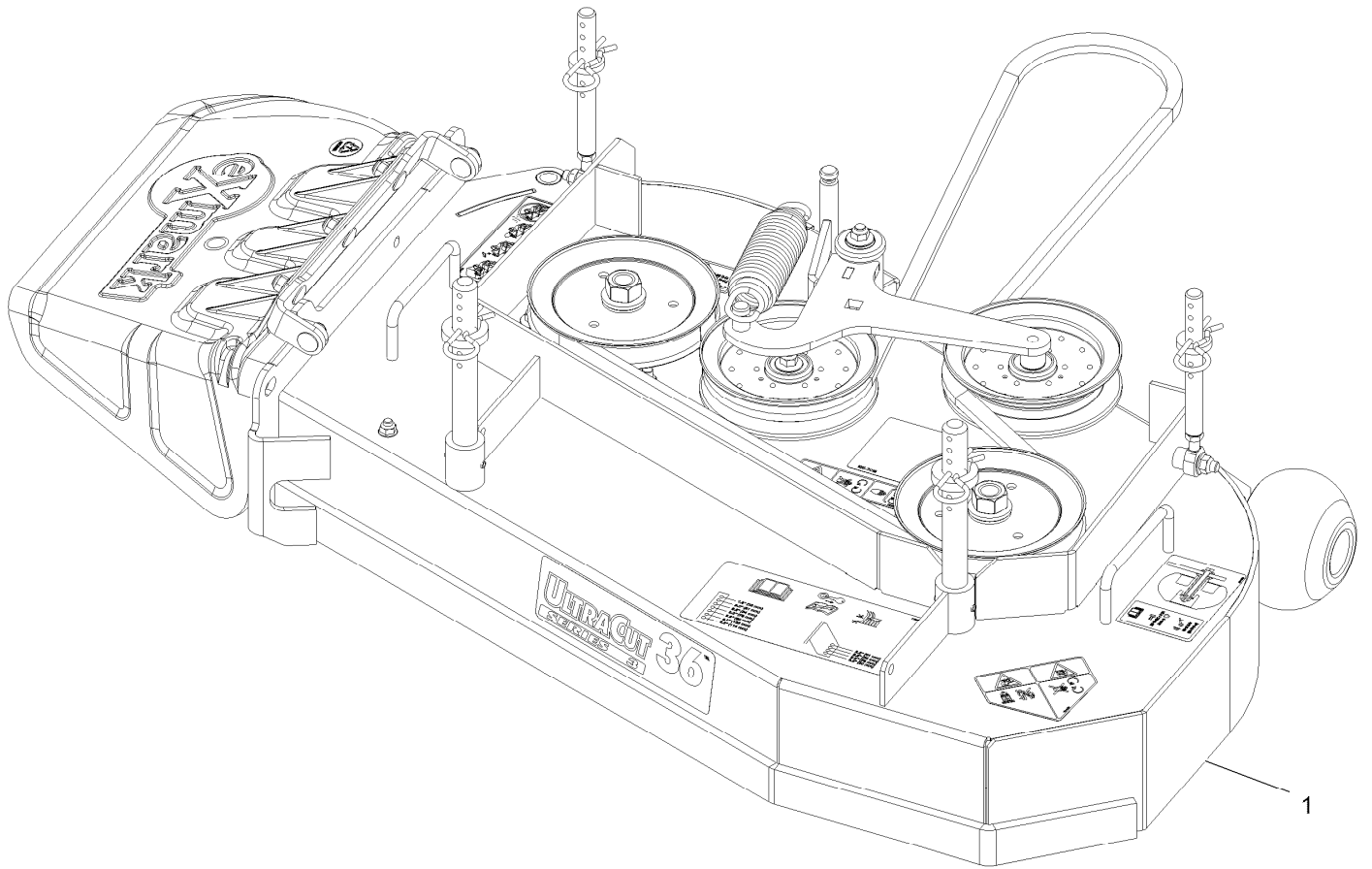

## Complete Deck Assembly

<i>Ref.</i>	<i>Part Number</i>	<i>Qty.</i>	<i>Description</i>
1	126-1908	1	ASM-Complete Deck 36

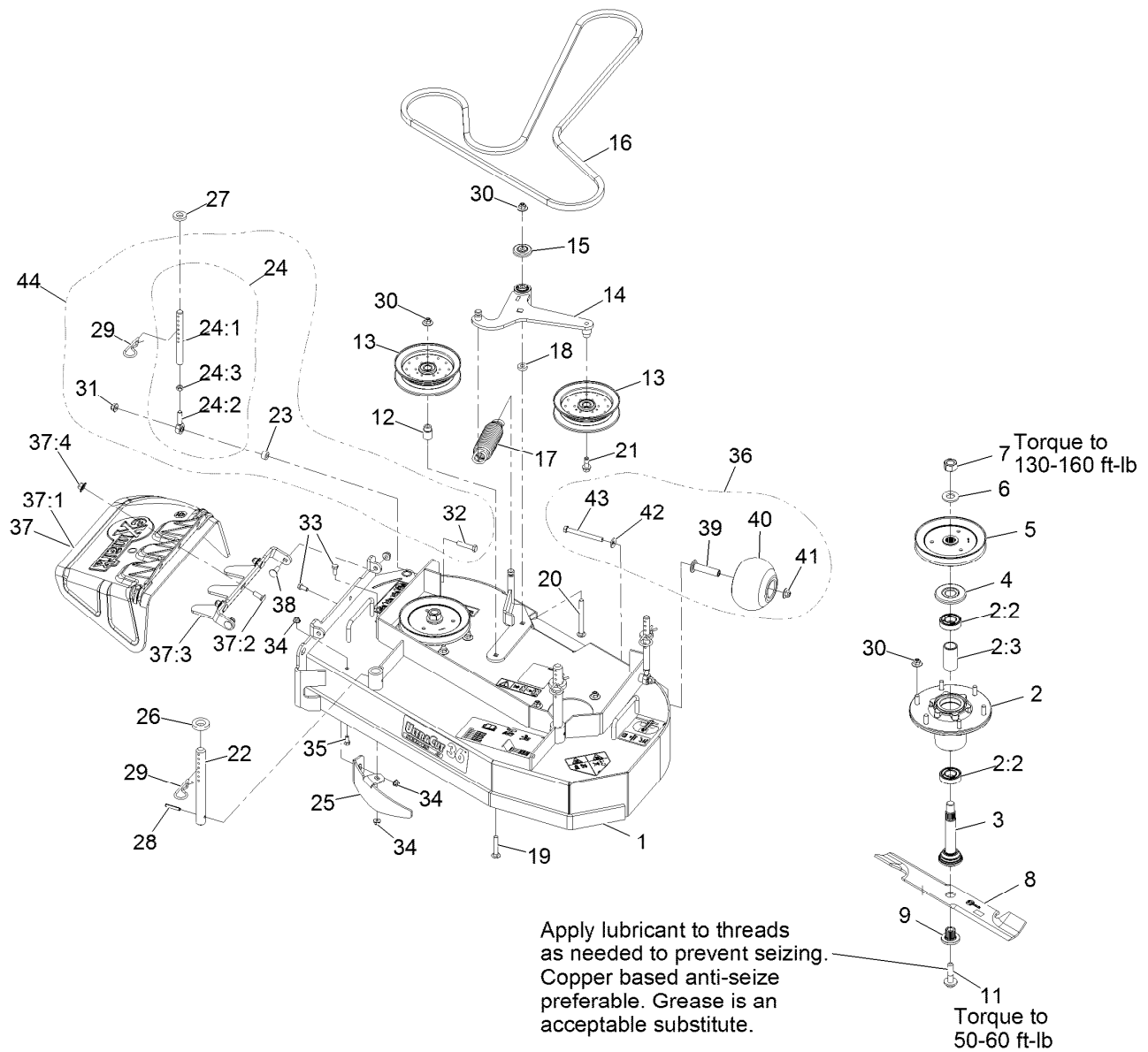

## Deck Assembly

Ref.	Part Number	Qty.	Description	Ref.	Part Number	Qty.	Description
1	126-0634	1	ASM, Deck W/ Decals, 36"	14	126-2204	1	ASM-Arm, Idler
2	116-3344	2	ASM-Cutter Hsg With Bearings	15	103-2916	1	Guard-Top
2:2	116-0720	2	Bearing-Ball	16	126-2222	1	Belt-5V
2:3	116-3312	1	Spacer-Bearing	17	116-6317	1	Spring-Extension
3	116-3342	2	ASM-Spindle And Seal ●	18	5-0652	1	Spacer
4	116-1286	2	Guard,Bearing Top .989	19	3231-7	1	Bolt-Carriage 3/8-16 X 2 1/4
5	116-0675	2	Sheave,Blade Drive 6.50	20	3231-37	1	Bolt-Carriage 3/8-16 X 4
6	103-2802	2	Washer-Spring Disc 3/4	21	126-1680	1	Screw-Hfh
7	116-7306	2	Nut-Hex	22	1-603001	2	Rod, Deck Support
8	103-6382	2	Blade, Solid	23	1-603050	2	Spacer
8	103-6387	2	Blade, Low Lift	24	1-414521	2	Link Assy
8	103-6392	2	Blade, Mulching	24:1	1-413525	1	Link, Rear Deck Support
8	103-6402	2	Blade-Notched	24:2	1-613204	1	Balljoint
8	116-5175	2	Blade-Extreme 2, 18.00"	24:3	3220-3	1	Nut-Jam 3/8-24
9	103-3037	2	Bushing, Splined	25	126-2783-01	1	Baffle, Dogleg
11	109-9220	2	Screw-Sems 1/2-20 X 2.19	26	1-413425	2	Spacer-Deck Support
12	126-2213	1	Bushing-Idler	27	1-323539	2	Spacer-Blade Drive
13	116-4668	2	Idler-Pulley, Flanged	28	1-806332	2	Rollpin 1/4 X 1 1/2
				29	1-806009	4	Hairpin-Cotter #206

● Apply Mobil HTS grease (P/N 103-5217 1.5 oz packet) (or a food-grade anti-seize). See operator s manual for locations.

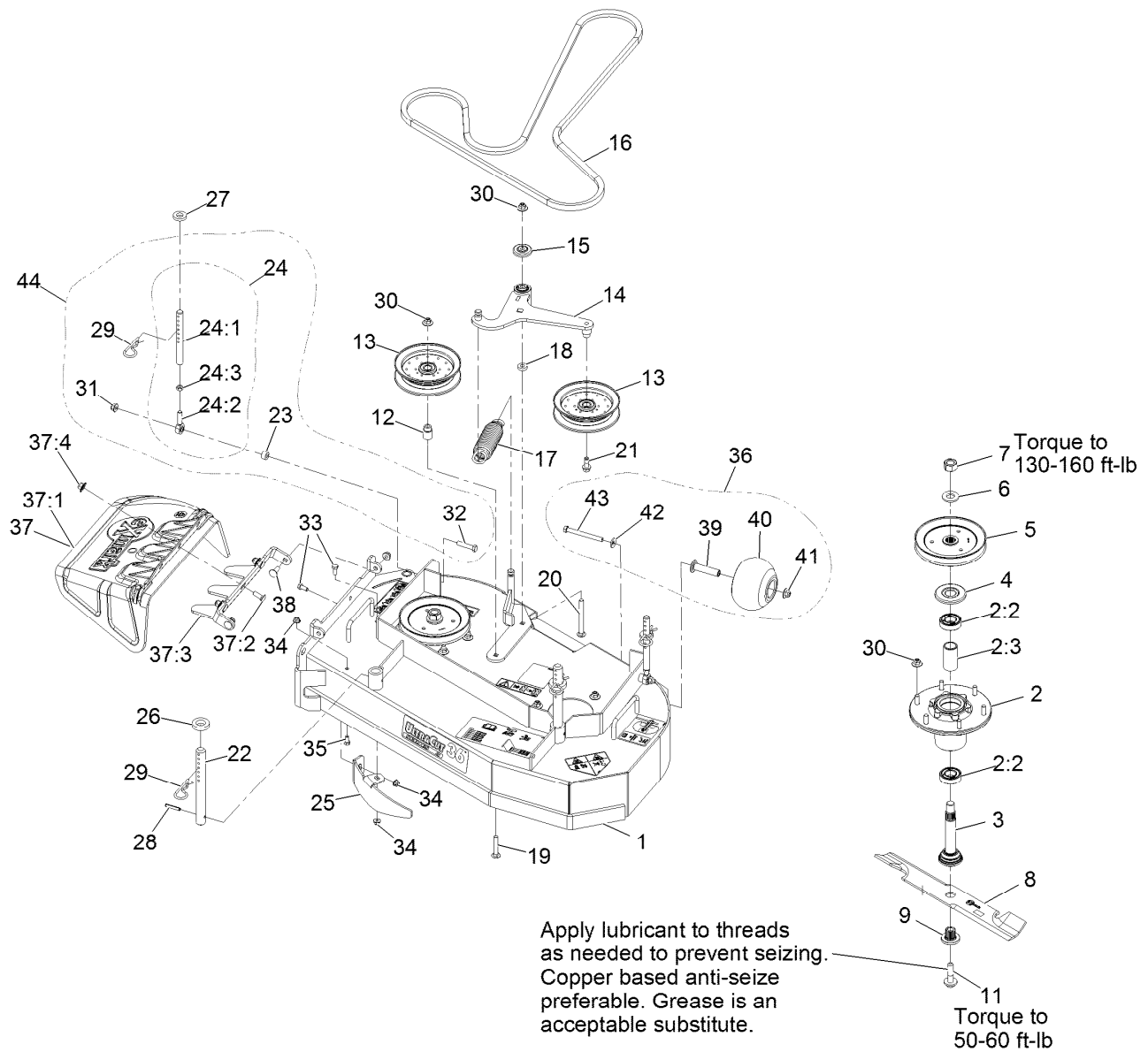

## Deck Assembly (continued)

Ref.	Part Number	Qty.	Description	Ref.	Part Number	Qty.	Description
30	109-6658	13	Nut-Nyloc 3/8-16 Flg	37:3	3231-22	3	Bolt-Carriage 3/8-16 X 1
31	104-8301	5	Nut-Nyloc 3/8-16 Flg	37:4	109-6658	3	Nut-Nyloc 3/8-16 Flg
32	323-9	2	Screw-HH 3/8-16 X 1 3/4	38	3231-22	2	Bolt-Carriage 3/8-16 X 1
33	322-3	2	Screw-HH 5/16-18 X 3/4	39	116-8131	1	Axle, Roller
34	104-8300	3	Nut-Nyloc 5/16-18 Flg	40	103-8415	1	Roller-Anti-Scalp
35	322-2	1	Screw-HH 5/16-18 X 5/8	41	109-6658	1	Nut-Nyloc 3/8-16 Flg
36	116-9981	1	Kit, Anti-Scalp Roller	42	98-5975	1	Washer-Spring Disc 3/8
37	126-0959	1	ASM, Discharge Chute	43	116-9362	1	Screw-HH 3/8-16 X 3 3/4 Gr 8
37:1	109-2738	1	Chute, Discharge	44	1-411532	2	Kit, Support Link W/Pin
37:2	126-0958-01	1	Bracket, Discharge Chute				

● Apply Mobil HTS grease (P/N 103-5217 1.5 oz packet) (or a food-grade anti-seize). See operator s manual for locations.

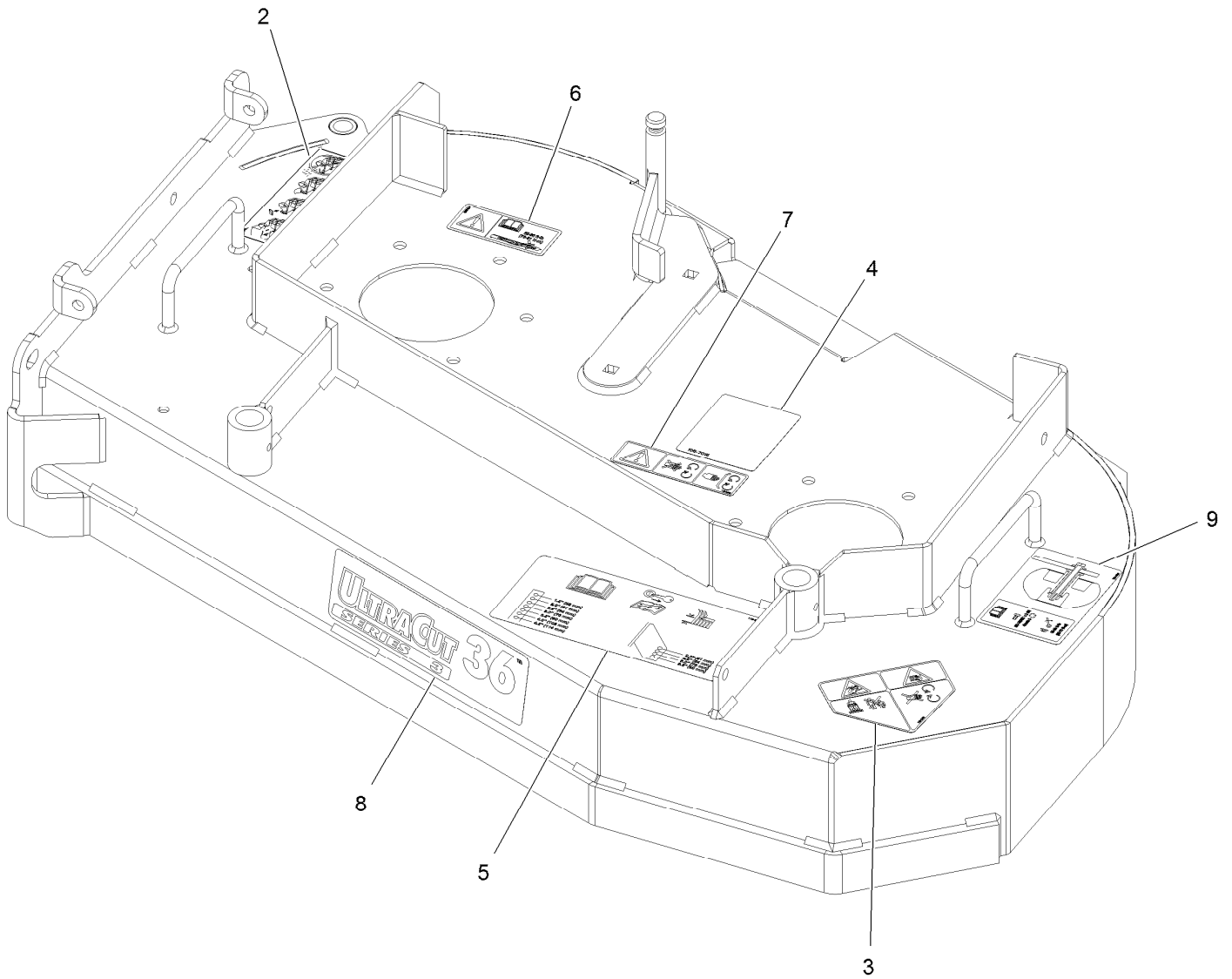

## Deck W/Decals Assembly No. 126-0634

<i>Ref.</i>	<i>Part Number</i>	<i>Qty.</i>	<i>Description</i>
2	114-3489	1	Decal-Warning, Bagger
3	112-8760	1	Decal-Danger
4	105-7015	1	Decal-Routing, Belt
5	116-8278	1	Decal-Anti-Scalp
6	116-8283	1	Decal-Bolt Torque
7	112-9028	1	Decal-Missing Cover
8	116-4695	1	Decal-Ultracut 36 Series 3
9	126-0898	1	Decal-Roller Mounting

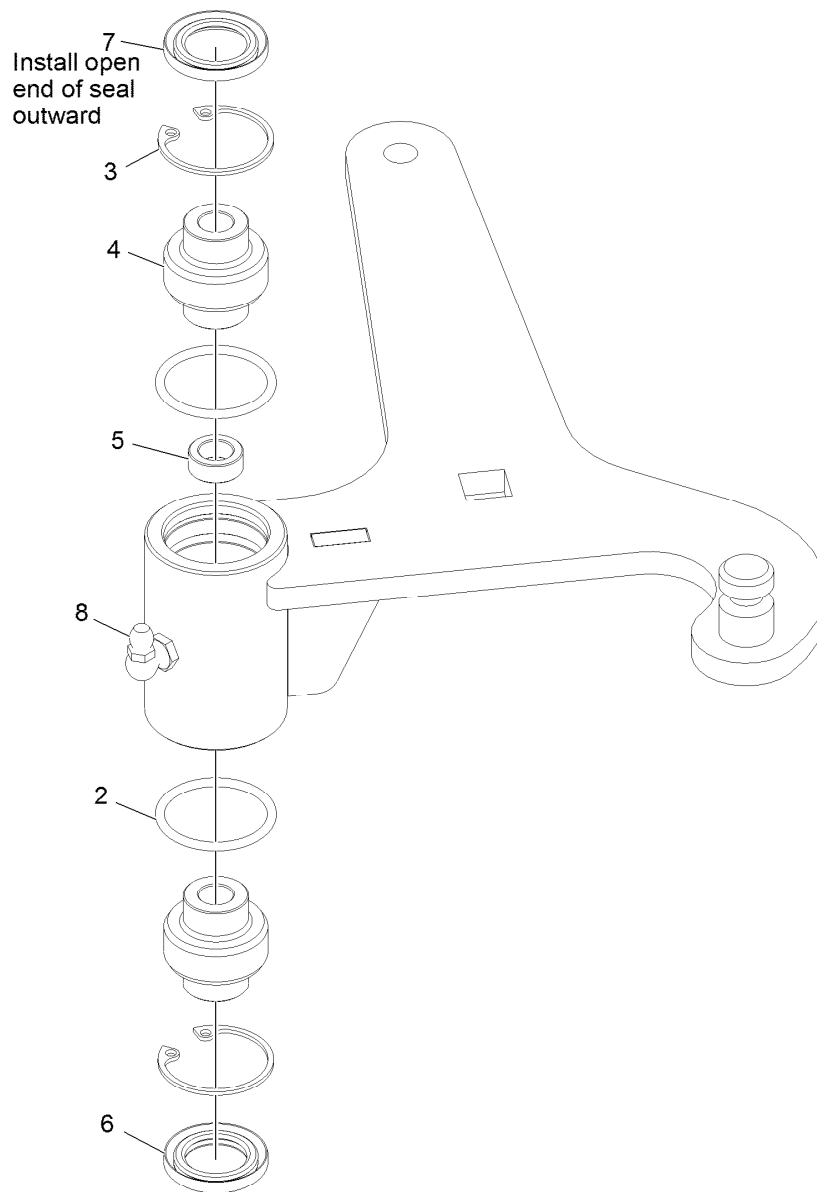

## Deck Idler Assembly No. 126-2204

<i>Ref.</i>	<i>Part Number</i>	<i>Qty.</i>	<i>Description</i>
2	106-7159	2	O-Ring
3	32120-10	2	Ring-Snap
4	103-3504	2	Bearing-Spherical
5	103-5677	1	Spacer
6	103-3505	1	Seal-Double Lip
7	103-3506	1	Seal-Lip, Single
8	302-40	1	Fitting-Grease, 90 DEG



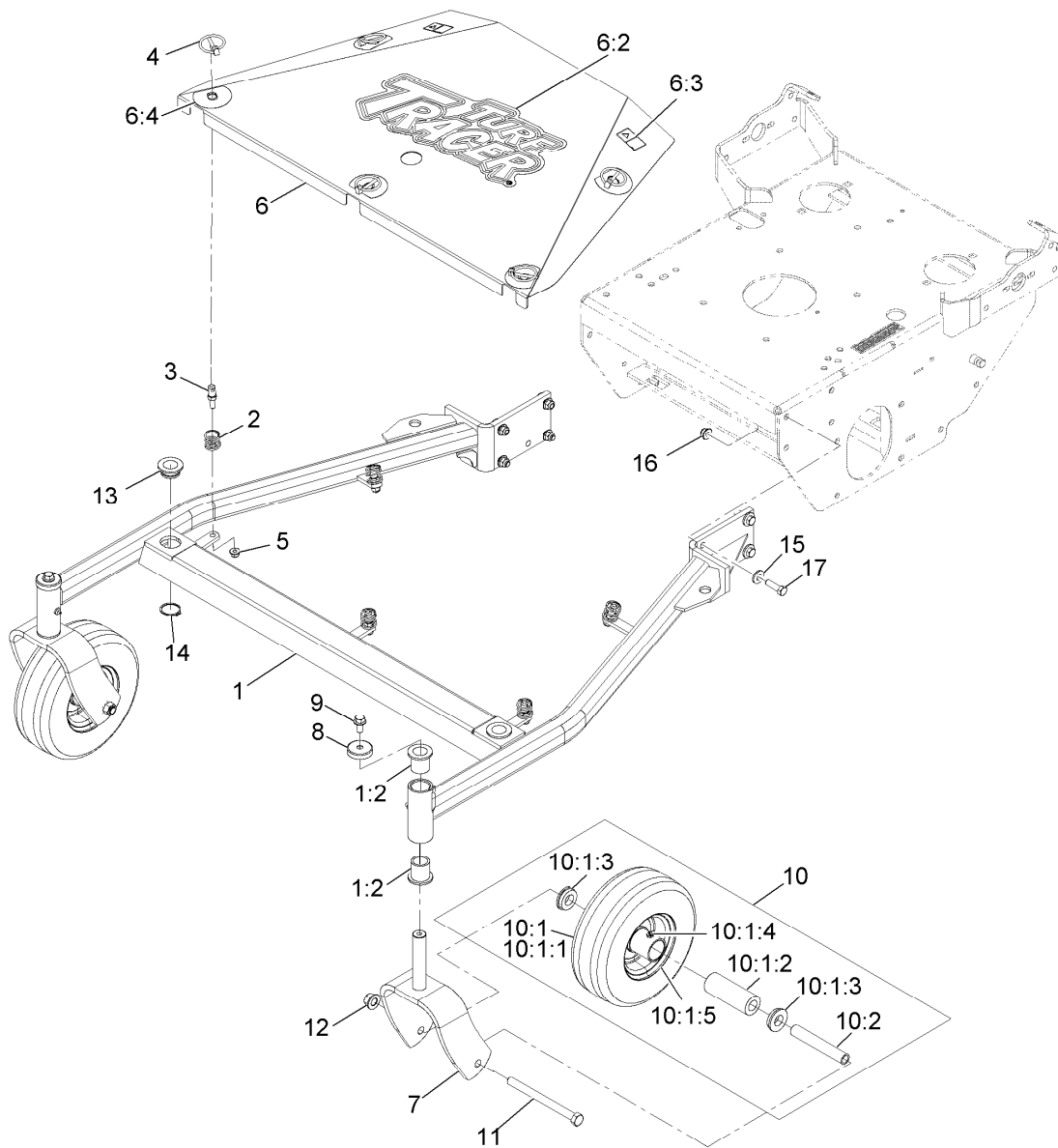

## Main Frame Assembly

Ref.	Part Number	Qty.	Description	Ref.	Part Number	Qty.	Description
1	126-1513	1	ASM, Frame W/ Bushings, 36	10:1		1	Wheel And Tire ASM ●
1:2	1-303514	4	Bearing-Flanged	10:1:1		1	Tire ●
2	126-1503	4	Spring	10:1:2	1-513809	1	Bearing
3	126-1504	4	Pin, Spring	10:1:3	1-513810	2	Bushing-Flanged
4	92-1298	4	Pin-Lynch	10:1:4	302-61	1	Zerk-45° 1/4-28
5	104-8300	4	Nut-Nyloc 5/16-18 Flg	10:1:5		1	Wheel ●
6	126-1516	1	ASM, Shield W/ Decals, 36	10:2	1-513547	1	Spacer
6:2	103-3013	1	Decal, Turf Tracer	11	325-20	2	Screw-HH 1/2-13 X 6
6:3	106-5517	2	Decal-Warning, Hot Surface	12	99-5107	2	Nut-Lock 1/2-13
6:4	126-1692	4	Decal-Scratch Cover	13	1-513336	2	Bushing-Deck
7	116-7941-01	2	Fork, Caster [red]	14	32120-33	2	Ring-Retaining
8	126-1425	2	Cap, Dust	15	98-5975	8	Washer-Spring Disc 3/8
9	110-1718	2	Screw-HHF	16	104-8301	8	Nut-Nyloc 3/8-16 Flg
10	1-513547	2	Spacer	17	323-7	8	Screw-HH 3/8-16 X 1 1/4
10	103-2171	2	Kit, Semi-Pneumatic Wheel Replacement				

● Not serviced separately

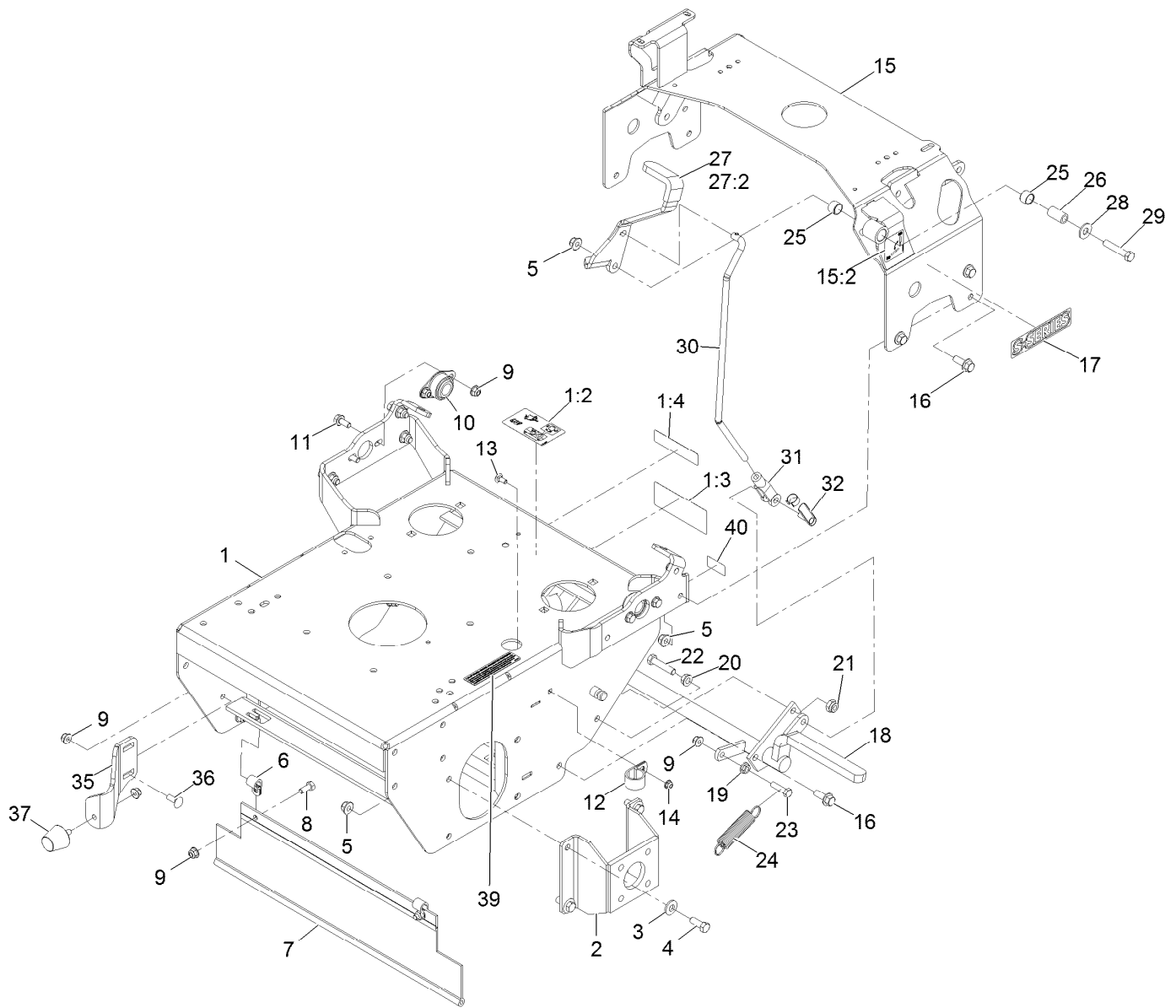

## Engine Deck

Ref.	Part Number	Qty.	Description	Ref.	Part Number	Qty.	Description
1	126-1238	1	ASM, Engine Deck W/ Decals	16	3234-42	9	Screw HHF 3/8-16 X 1
1:2	116-8253	1	Decal-Drive Release	17	116-3884	2	Decal-S-Series
1:3	126-1400	1	Decal-Warning, Sulky	18	126-1599	1	Shaft-Cross, Brake
1:4	98-1977	1	Decal-Warning	19	32128-20	1	Nut-Whizlock 5/16-18
2	1-412080-01	2	Mount, Wheel Motor 36"	20	3290-357	1	Nut-Whizlock 3/8-16
3	98-5975	8	Washer-Spring Disc 3/8	21	3296-44	1	Nut-Lock, NI
4	323-6	8	Screw-HH 3/8-16 X 1	22	323-9	1	Screw-HH 3/8-16 X 1 3/4
5	104-8301	18	Nut-Nyloc 3/8-16 Flg	23	322-6	1	Screw-HH 5/16-18 X 1 1/4
6	1-413510	2	Clip-Loom	24	1-323161	1	Spring
7	103-2056	1	Shield-Drag	25	1-413347	2	Sleeve-Bushing
8	322-3	2	Screw-HH 5/16-18 X 3/4	26	1-413344	1	Bushing-Pivot
9	104-8300	10	Nut-Nyloc 5/16-18 Flg	27	126-2180	1	ASM, Brake Lever W/ Grip
10	1-633102	2	Bearing-Flanged	27:2	1-303020	1	Grip-Lever
11	3234-47	4	Screw-HH Flg 5/16-18 X 3/4	28	3256-4	1	Washer-3/8 Std
12	1-643312	1	Clip-Loom	29	323-10	1	Screw-HH 3/8-16 X 2
13	3229-11	1	Bolt-Carriage 1/4-20 X 5/8	30	116-9959	1	Linkage, Brake
14	104-7201	1	Nut-Nyloc 1/4-20 Flg	31	1-633131	1	Yoke-Linkage, Brake
15	126-2181	1	ASM, Tank Support W/ Decal	32	103-2399	1	Pin-Clevis Spring 3/8
15:2	116-5988	1	Decal-Park Brake, Ce	35	126-2191-01	1	Bracket-Bumper
				36	3230-16	2	Bolt-Carriage 5/16-18 X 7/8
				37	1-543963	1	Bumper-Rubber

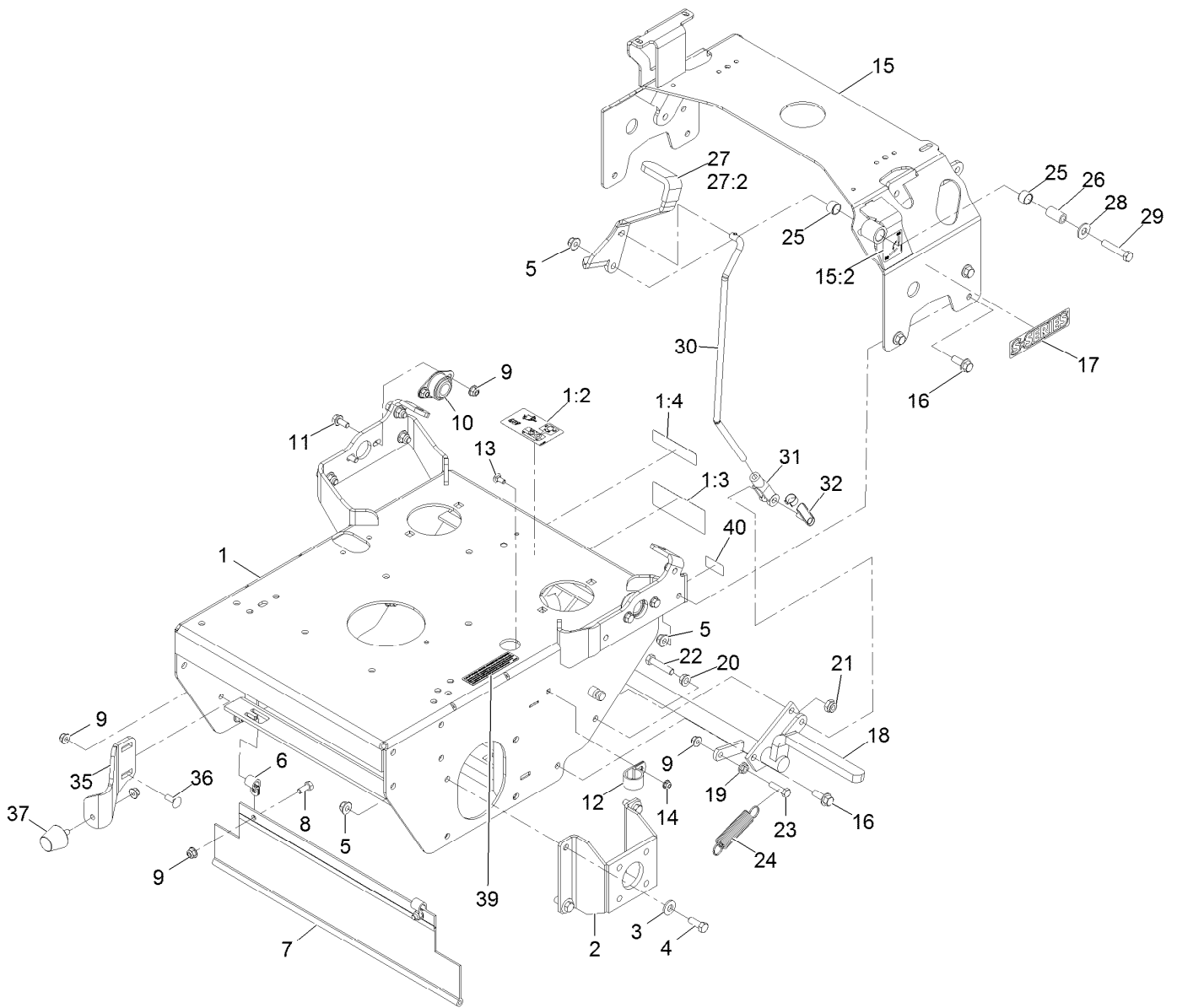

## Engine Deck (continued)

<i>Ref.</i>	<i>Part Number</i>	<i>Qty.</i>	<i>Description</i>
39	117-2718	1	Decal-Arrester, Spark
40	126-4345	1	Decal-Patent Ttco.Com

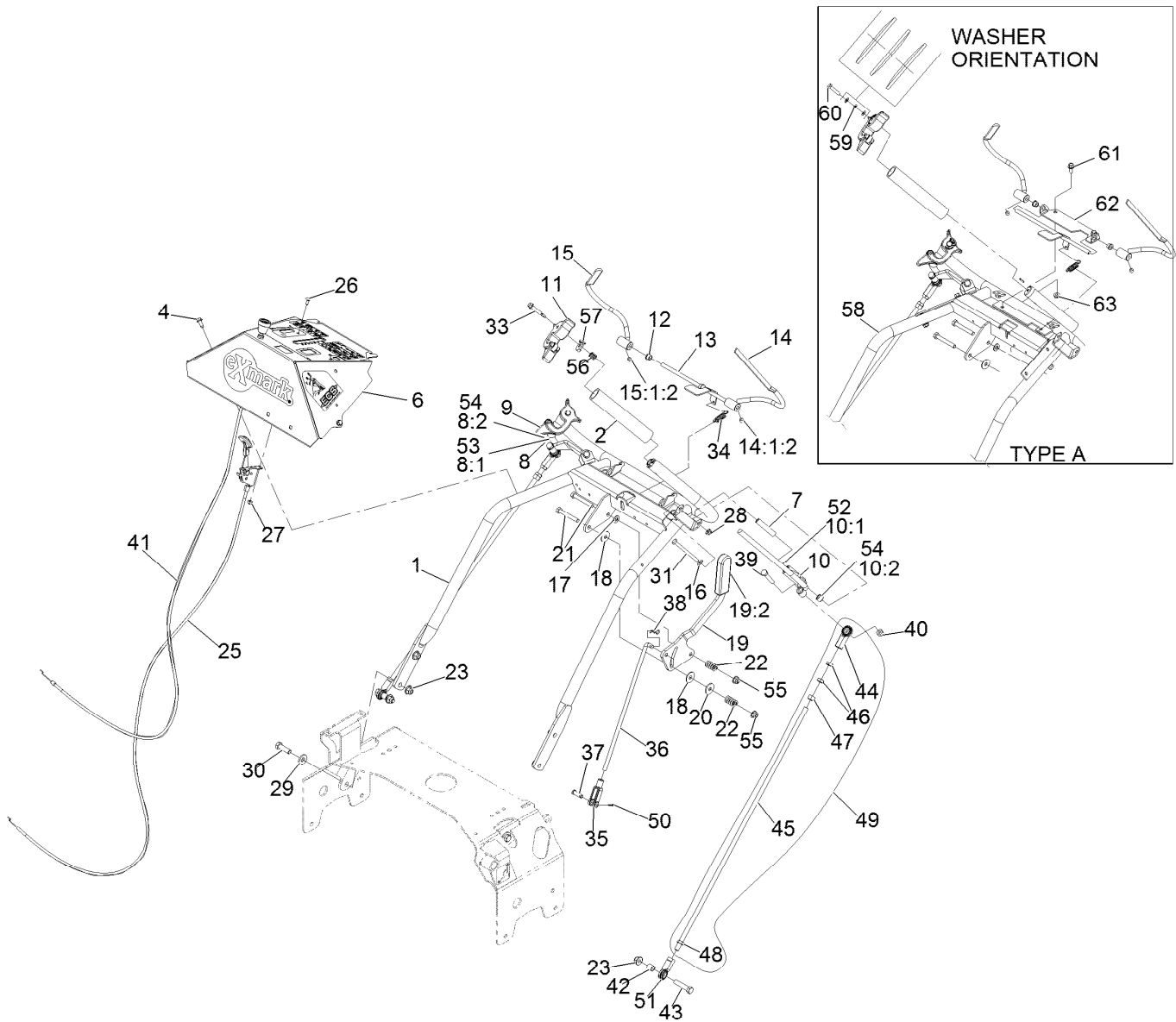

## Handle Assembly

Ref.	Part Number	Qty.	Description	Ref.	Part Number	Qty.	Description
1	126-2642-03	1	Weld, Handle	16	3256-22	2	Washer-1/4 Sae
2	103-0815	2	Grip-Bar, Handle	17	3256-23	1	Washer-5/16 Sae
4	32144-10	2	Screw-HWH 1/4-20 X .62	18	1-323244	2	Washer-Friction
6	126-4706	1	ASM, Console W/ Decals	19	126-0148	1	Lever, Shift W/Grip
7	103-0027	2	Bushing-Lever, Drive	19:2	103-5994	1	Grip-Handle, Steering
8	103-2513	1	Asm, Drive Lever RH	20	1-603716	1	Washer-Friction Disc
8:1	116-4082	1	Wld,RH Drive Lever	21	322-11	2	Screw-HH 5/16-18 X 2 1/4
8:2	1-413152	2	Bushing-Sleeve	22	1-323245	2	Spring-Compression
9	103-1371	1	Thumb Latch Asm RH	23	104-8301	6	Nut-Nyloc 3/8-16 Flg
10	103-2514	1	Asm, Drive Lever LH	25	109-3958	1	Control-Throttle
10:1	116-4081	1	Wld,LH Drive Lever	26	1-807513	2	Bolt-Carriage #10-24 X 1/2
10:2	1-413152	2	Bushing-Sleeve	27	3296-2	2	Nut-Nyloc #10-24
11	103-1372	1	Thumb Latch Asm LH	28	104-7201	2	Nut-Nyloc 1/4-20 Flg
12	1-303365	2	Bushing-Nylon	29	98-5975	4	Washer-Spring Disc 3/8
13	103-0769-03	1	Rod Weldment, Opc	30	323-7	4	Screw-HH 3/8-16 X 1 1/4
14	116-4079	1	Wld,LH Opc Lever ■	31	321-14	2	Screw-HH 1/4-20 X 2 3/4
14:1:2	1-803322	1	Setscrew-5/16-24 X 5/16 ●	33	126-2931	2	Screw-Shoulder
15	116-4080	1	Wld,RH Opc Lever ■	34	1-303363	1	Spring-Extension
15:1:2	1-803322	1	Setscrew-5/16-24 X 5/16 ●	35	1-303105	1	Yoke-Adjustable

● Use Pro-Lock, Nut Type (P/N 1-840022, .5ml tube) on threads.

■ Use Pro-Lock retaining type, Part no. 1-840023 (.5cc tube) on inside of bore of OPC hub.

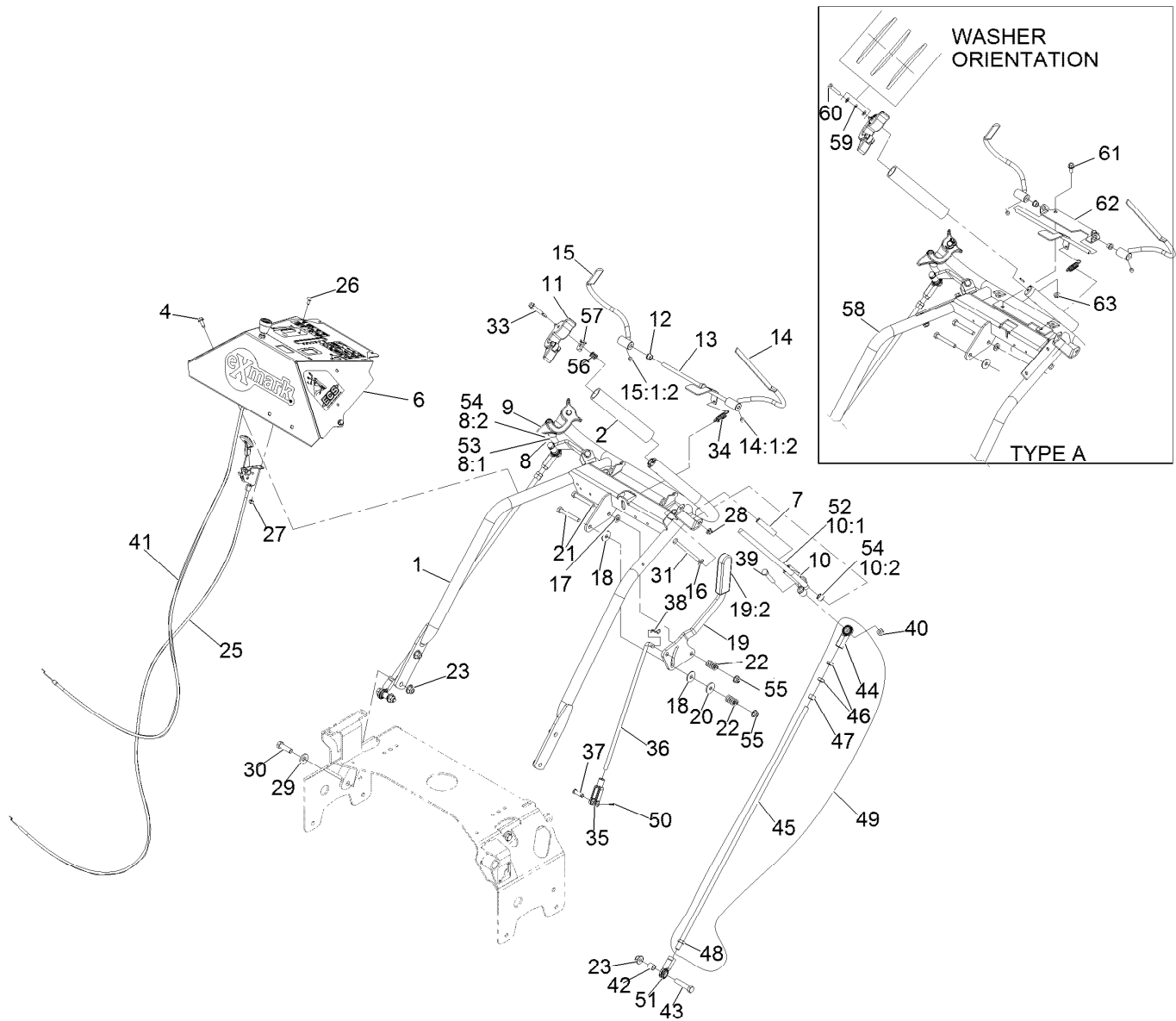

## Handle Assembly (continued)

Ref.	Part Number	Qty.	Description	Ref.	Part Number	Qty.	Description
36	1-413225	1	Rod, Speed Control	51	103-1167	2	Joint-Ball End
37	1-808280	1	Pin-Clevis 5/16 X 1 49/64	52	116-4081	1	Wld,LH Drive Lever
38	1-806003	1	Hairpin-Cotter	53	116-4082	1	Wld,RH Drive Lever
39	322-9	2	Screw-HH 5/16-18 X 1 3/4	54	1-413152	4	Bushing-Sleeve
40	3296-29	2	Nut-Nyloc 5/16-18	55	104-8300	2	Nut-Nyloc 5/16-18 Flg
41	126-2107	1	Cable, Choke	56	1-633349	2	Spring-Tank, Fuel
42	103-1166	2	Spacer-Tube, Pump Link	57	126-2921	2	Latch, Ecs
43	323-9	2	Screw-HH 3/8-16 X 1 3/4	58	126-0142-03	1	Wld,TTH Ecs Handle
44	103-2463	2	Balljoint	59	1-303435	6	Washer-Spring
45	103-1148	2	Rod,Drive Lever	60	103-0235	2	Screw-HH
46	3220-3	4	Nut-Jam 3/8-24	61	126-1592	8	Screw-Flange Head, 1/4-20 X .625
47	3219-3	2	Nut-Hex 3/8-24	62	103-0489-03	1	Bracket, Opc Axle
48	3220-16	2	Nut-Jam 3/8-24 LH	63	32128-33	8	Nut-HF
49	116-3414	2	Drive Link ASM				
50	3272-5	1	Pin-Cotter 3/32 X 1/2				

● Use Pro-Lock, Nut Type (P/N 1-840022, .5ml tube) on threads.

■ Use Pro-Lock retaining type, Part no. 1-840023 (.5cc tube) on inside of bore of OPC hub.

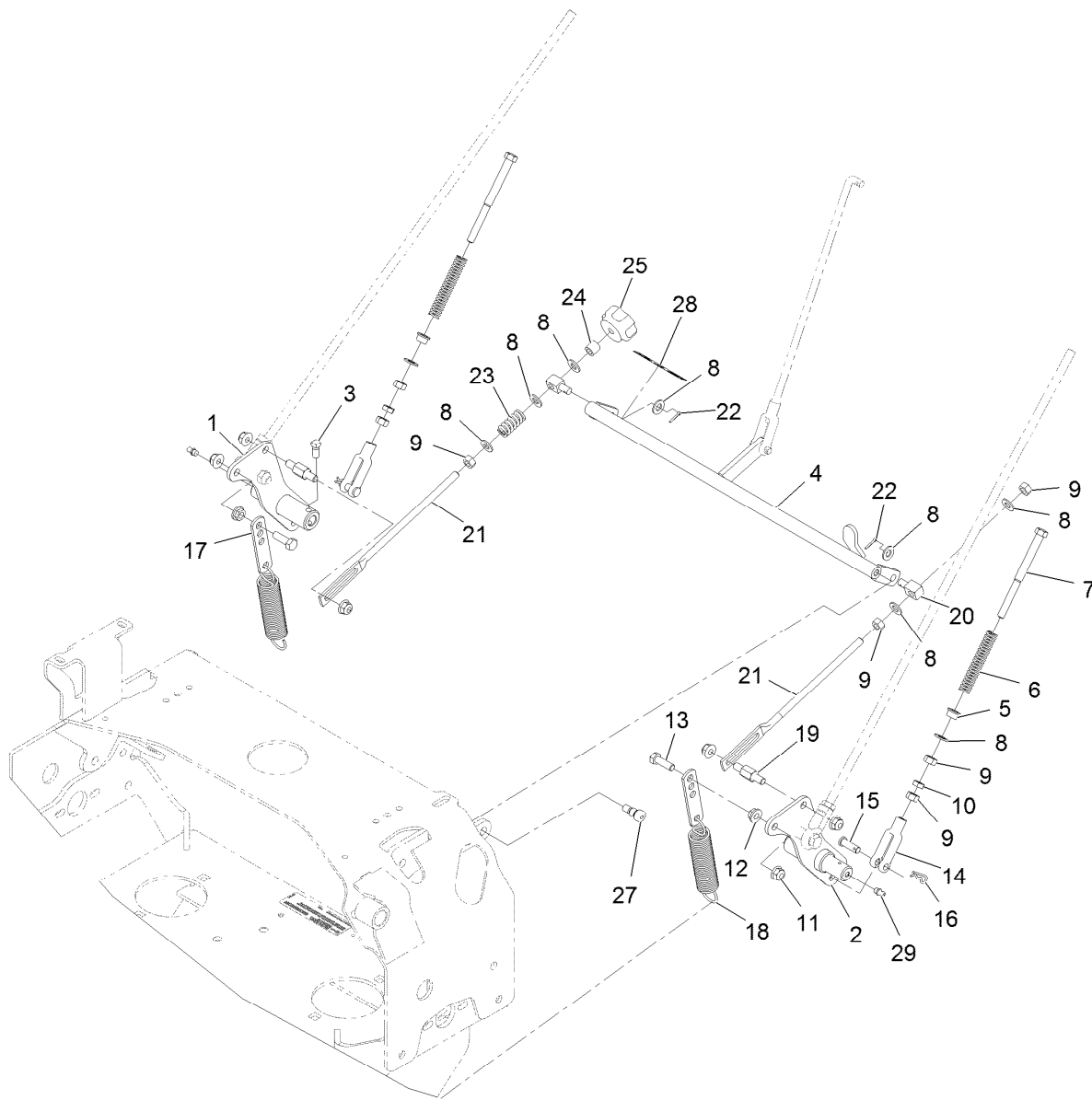

## Controls Assembly

<i>Ref.</i>	<i>Part Number</i>	<i>Qty.</i>	<i>Description</i>	<i>Ref.</i>	<i>Part Number</i>	<i>Qty.</i>	<i>Description</i>
1	116-9975	1	Weld, Motion Control, Rt	15	1-808280	2	Pin-Clevis 5/16 X 1 49/64
2	116-9974	1	Weld, Motion Control, Lt	16	1-806003	2	Hairpin-Cotter
3	1-803022	2	Setscrew-5/16-18 X 5/8	17	1-613089	2	Tab-Spring, Extension
4	126-2982-01	1	Weld, Speed Control	18	1-603693	2	Spring
5	1-603735	2	Bushing-Flanged	19	126-0610	2	Pin, Motion Control
6	103-0265	2	Spring, Neutral Return	20	1-603676	2	Swivel-Adjustable, Short
7	1-603737	2	Bolt-Neutral Return	21	1-413350	2	Link-Control, Speed
8	3256-23	9	Washer-5/16 Sae	22	3272-5	2	Pin-Cotter 3/32 X 1/2
9	3219-2	7	Nut-Hex 5/16-24	23	1-323245	1	Spring-Compression
10	3220-2	2	Nut-Jam 5/16-24	24	1-603903	1	Spacer
11	104-8300	6	Nut-Nyloc 5/16-18 Flg	25	103-3060	1	Knob-Tracking
12	32128-20	2	Nut-Whizlock 5/16-18	27	1-809056	2	Screw-Sh 5/16-18 X 1 3/8
13	322-5	2	Screw-HH 5/16-18 X 1	28	116-7918	1	Decal-Tracking Adjustment
14	1-303105	2	Yoke-Adjustable	29	302-19	2	Zerk-1/4-28 Str

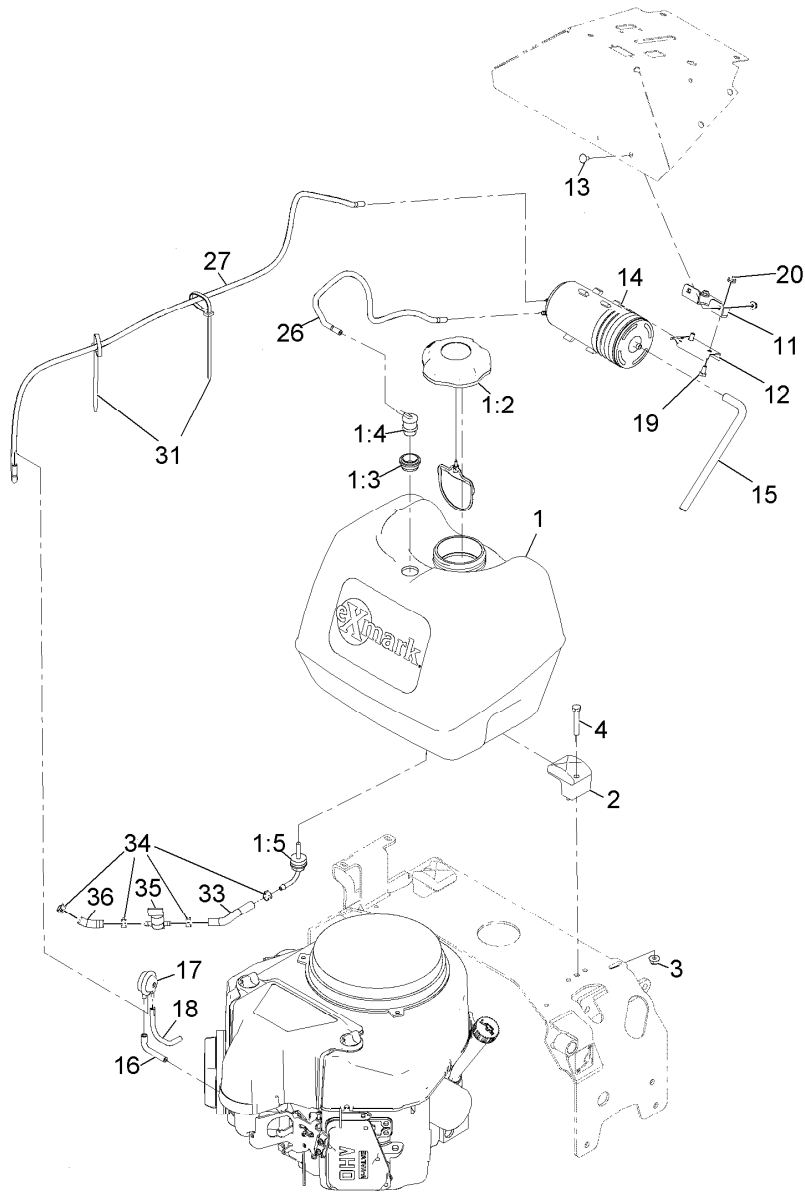

## Fuel Tank Assembly

Ref.	Part Number	Qty.	Description	Ref.	Part Number	Qty.	Description
1	126-1525	1	ASM, Fuel Tank	15	115-0962	1	Hose-Vent, Canister
1:2	120-5461	1	Cap-Fuel, Ratcheting	16	116-2233	2	Hose-Vent, Formed
1:3	114-0284	1	Grommet	17	116-2232	1	Valve-Control, Vacuum
1:4	119-3547	1	Valve-Vent, Fuel	18	116-2394	1	Hose-Vent, Formed
1:5	103-2605	1	Fitting-Fuel Bulkhead W/Strainer ●	19	321-2	2	Screw-HH 1/4-20 X 1/2
2	107-4543	2	Clamp	20	104-7201	4	Nut-Nyloc 1/4-20 Flg
3	104-8300	2	Nut-Nyloc 5/16-18 Flg	26	114-0286	1	Hose-Vent
4	322-10	2	Screw-HH 5/16-18 X 2	27	116-3116	1	Hose-Vent, Formed
11	115-4486-01	1	Bracket-Canister, Carbon	31	1-303335	2	Tie-Cable 7 15/16 (Large)
12	114-0292	1	Bracket-Canister, Carbon	33	109-0650	1	Hose-Fuel
13	3229-10	2	Bolt-Carriage 1/4-20 X 1/2	34	2412-98	4	Clamp-Hose
14	117-1221	1	Canister-Carbon, 800Cc	35	1-603770	1	Valve-Fuel
				36	99-9415	1	Hose-Fuel

● Use Pro-Lock, Nut Type (P/N 1-840022, .5ml tube) on threads.

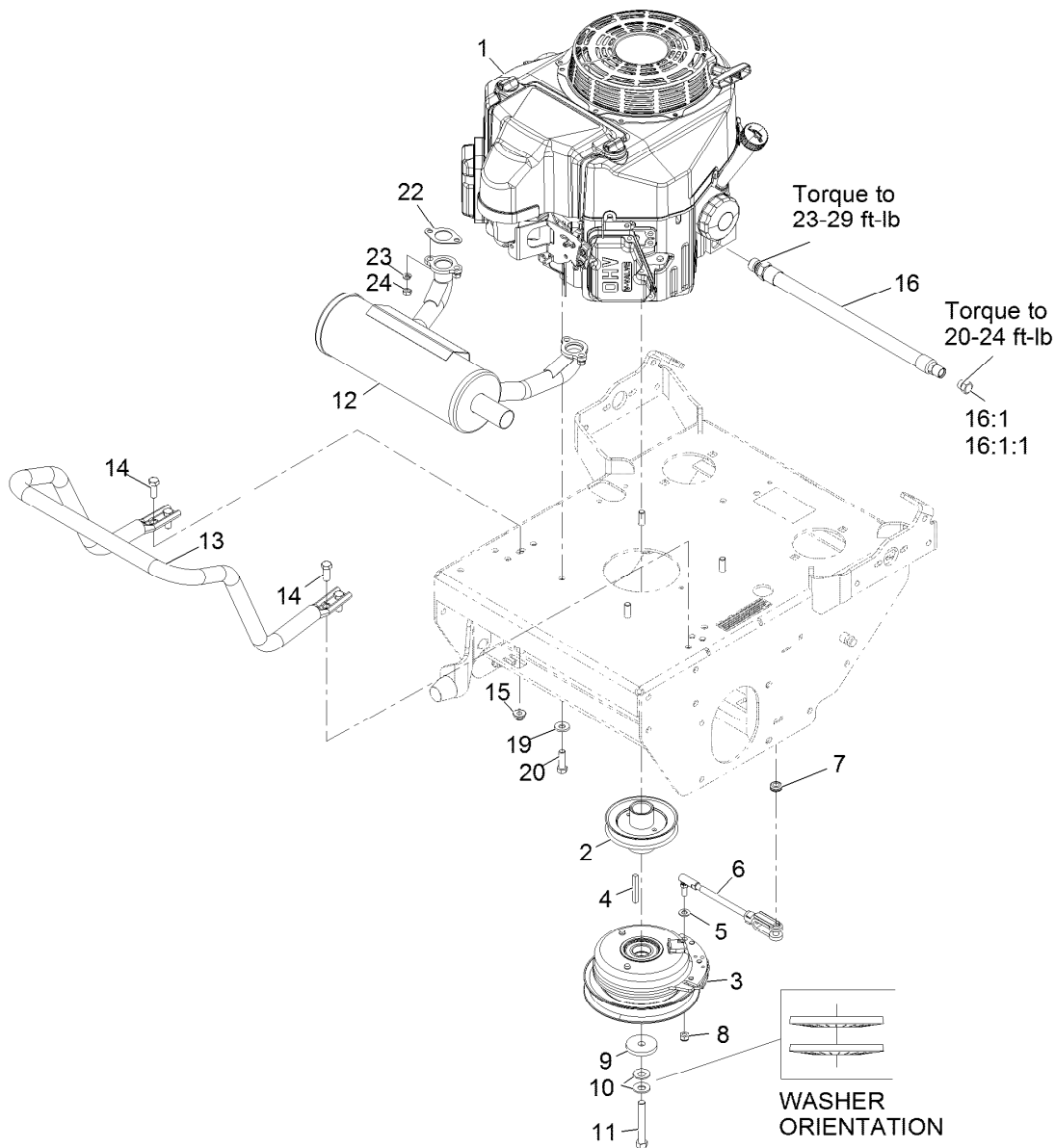

## Engine Assembly

Ref.	Part Number	Qty.	Description	Ref.	Part Number	Qty.	Description
1		1	Engine, Kawasaki 481Cc ●■	13	116-6278-03	1	Guard-Muffler
2	116-7328	1	Sheave, W/ Hub	14	323-6	4	Screw-HH 3/8-16 X 1
3	126-2615	1	Clutch, 105 Ft/Lbs, 1.13	15	104-8301	4	Nut-Nyloc 3/8-16 Flg
4	5-1336	1	Key-Machine 1/4 X 1/4 X 2 □	16	116-5052	1	Asm-Oil Drain Hose W/Plug
5	3256-23	1	Washer-5/16 Sae				▲
6	126-0620	1	ASM, Clutch Anchor	16:1	353-508	1	Plug-W/O-Ring
7	237-136	1	Grommet	16:1:1	237-42	1	O-Ring
8	3296-4	1	Nut-Lock 5/16-24	19	98-5975	4	Washer-Spring Disc 3/8
9	109-6919	1	Washer-Clutch	20	323-7	4	Screw-HH 3/8-16 X 1 1/4
10	1-603610	2	Washer-Spring Disc 7/16	22	1-653313	2	Gasket-Exhaust
11	3212-12	1	Screw-HH 7/16-20 X 3 ◆	23	114-3550	4	Washer-Lock, Spring
12	116-3735	1	Muffler-Horizontal	24	114-3549	4	Nut-M8

● Not serviced separately

▲ Use a Teflon Pipe Sealant or equivalent on threads.

◆ Use Pro-Lock, Nut Type (P/N 1-840022, .5ml tube) on threads.

□ Apply anti-seize compound to engine crankshaft, pulley hub I.D., clutch bore I.D. and square key.

■ Obtain parts from [www.kawpowerepc.com](http://www.kawpowerepc.com)



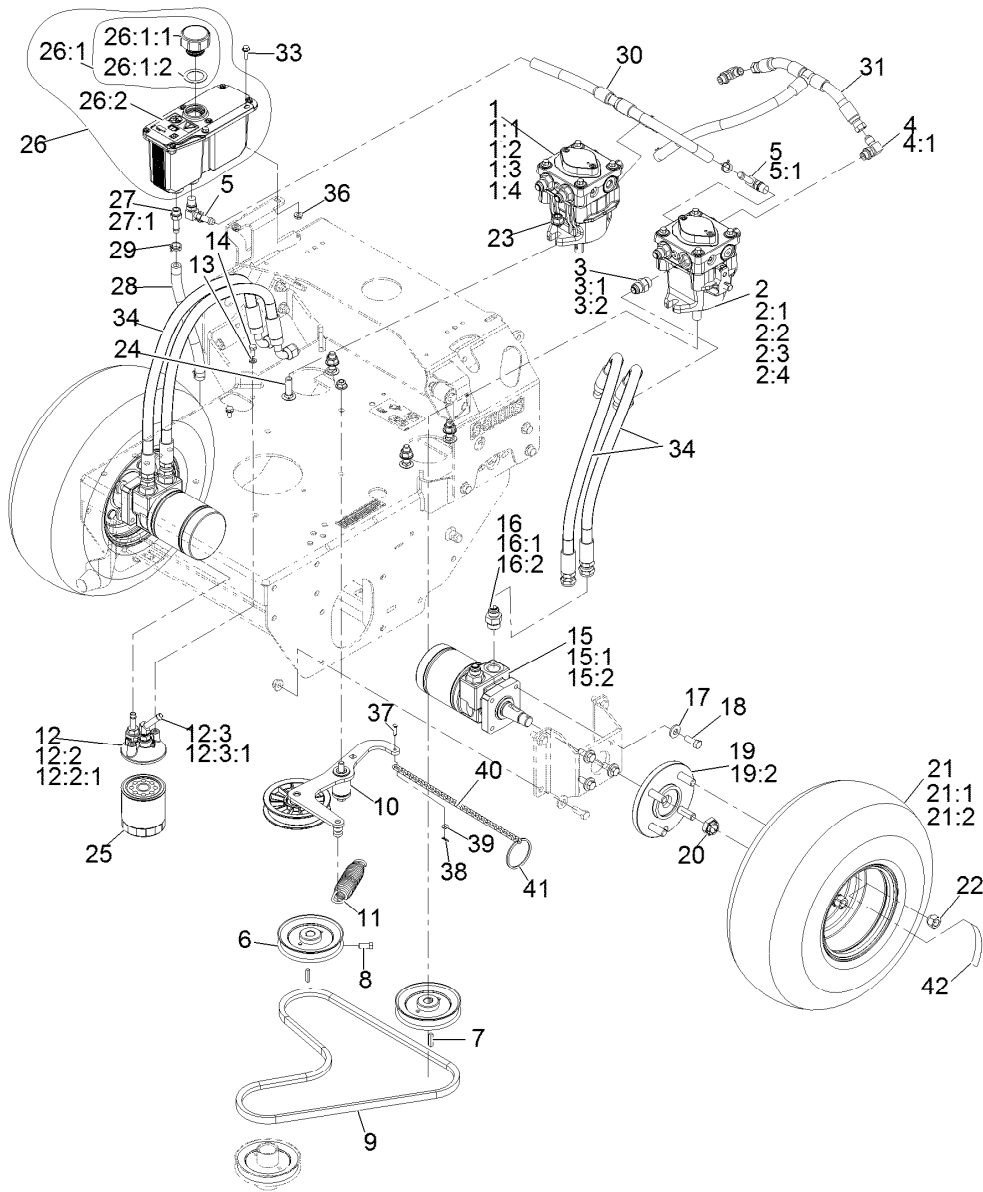

## Ground Drive Assembly

Ref.	Part Number	Qty.	Description	Ref.	Part Number	Qty.	Description
1	116-0943	1	RH HYD Pump ASM	8	120-6474	4	Screw-Set, SQH 5/16-18 X 3/4
1:1	103-2664	1	Input Shaft Kit	9	103-4761	1	Belt
1:2	94-6922	1	Bearing-Thrust	10	126-0615	1	ASM, Pump Idler
1:3	103-2666	1	Cylinder Block Kit	11	116-6316	1	Spring-Extension
1:4	105-6184	1	Seal Overhaul Kit	12	126-0621	1	ASM, Filter Head
2	116-0942	1	LH HYD Pump ASM	12:2	103-1912	1	Adapter-Straight
2:1	103-2664	1	Input Shaft Kit	12:2:1	237-42	1	O-Ring
2:2	94-6922	1	Bearing-Thrust	12:3	103-1807	1	Fitting-Barbed, 45 DEG
2:3	103-2666	1	Cylinder Block Kit	12:3:1	237-42	1	O-Ring
2:4	105-6184	1	Seal Overhaul Kit	13	1-805004	2	Washer-Lock 1/4 Heavy
3	1-603990	4	Adapter-Straight	14	321-3	2	Screw-HH 1/4-20 X 5/8
3:1	1-603920	1	O-Ring-Sae #8	15	1-603718	2	HYD Motor ASM
3:2	1-603992	1	O-Ring-37 Flare #8	15:1	1-000119	1	Seal Kit
4	103-1802	2	Fitting-HYD, 90 DEG	15:2	1-000138	1	Bearing And Seal Kit
4:1	1-603921	1	O-Ring-Sae #6	16	1-603991	4	Adapter-Straight
5	100-4887	3	Fitting-Barbed, 90 DEG	16:1	237-80	1	O-Ring
5:1	237-42	1	O-Ring	16:2	1-603992	1	O-Ring-37 Flare #8
6	1-413010	2	Sheave ASM	17	98-5975	8	Washer-Spring Disc 3/8
7	1-807272	2	Key-5Mm X 5Mm X 25Mm				

● Not serviced separately

■ Use Exmark Premium Hydro Oil P/N 109-9828 (32oz)

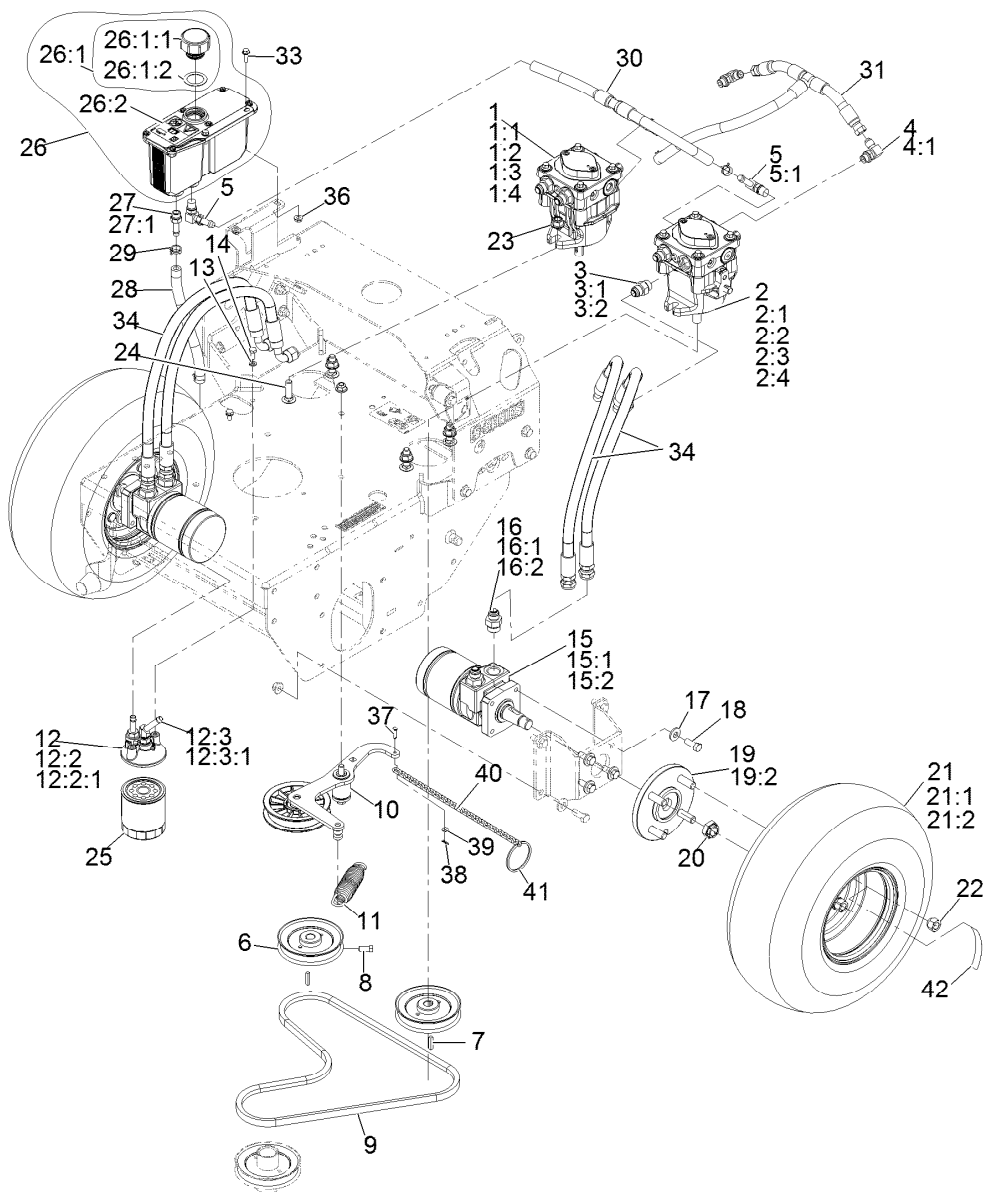

## Ground Drive Assembly (continued)

Ref.	Part Number	Qty.	Description	Ref.	Part Number	Qty.	Description
18	323-6	8	Screw-HH 3/8-16 X 1	27	103-1912	1	Adapter-Straight
19	112-9049	2	Wheel Hub ASM	27:1	237-42	1	O-Ring
19:2	1-633926	4	Stud-Wheel	28	103-2959	1	Hose-Charge
20	116-2839	2	Nut-Lock	29	103-1988	6	Clamp-Hose 11/16
21	1-413473	2	Wheel And Tire ASM	30	126-0623	1	Hose-Case Drain
21:1	1-413474	1	Tire-Turfmaster	31	126-0622	1	Hose-Charge
21:2	1-603715	1	Wheel-Rim	33	32105-15	2	Screw-Machine 1/4-20 X 3/4
22	242-50	8	Nut-Lug 1/2-20	34	119-7827	4	HYD Hose ASM
23	114-8417	4	Nut-HF, NI	36	32128-33	2	Nut-Whizlock 1/4-20
24	3232-3	4	Bolt-Carriage 7/16-14 X 1 1/2	37	283-16	1	Pin-Clevis
25	109-4180	1	Element, Oil Filter	38	108-2992	1	Pin-Hair
26	126-1248	1	ASM, HYD Reservoir ■	39	3269-26	1	Washer-Plain
26:1		1	Reservoir-HYD ●	40	1-323365	1	Chain-Link, Twist
26:1:1	103-1948	1	Cap-Reservoir, HYD	41	1-323366	1	Ring-Split
26:1:2	103-1949	1	Gasket-Cap	42	126-2056	2	Decal-Torque Wheel Lug-Hub
26:2	115-4212	1	Decal-Warning				

● Not serviced separately

■ Use Exmark Premium Hydro Oil P/N 109-9828 (32oz)

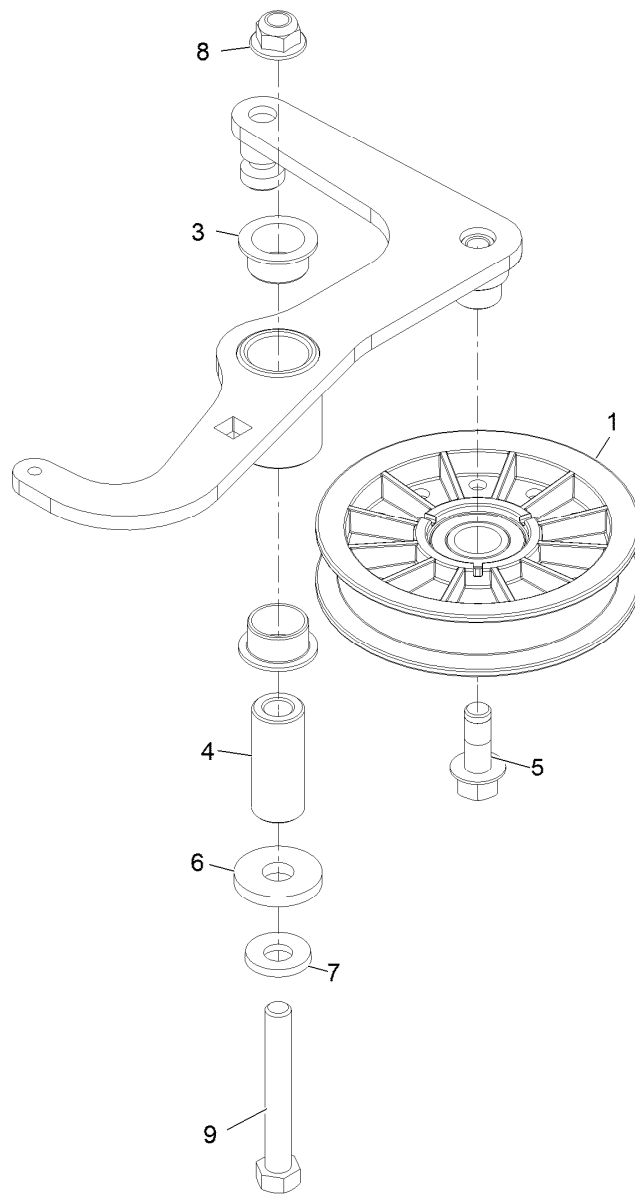

## Pump Idler Assembly No. 126-0615

<i>Ref.</i>	<i>Part Number</i>	<i>Qty.</i>	<i>Description</i>
1	109-4077	1	Pulley-Idler, Flat
3	109-8054	2	Bushing-Flanged
4	116-8718	1	Spacer, Pivot
5	126-1680	1	Screw-Hfh
6	1-373034	1	Washer
7	98-5975	1	Washer-Spring Disc 3/8
8	104-8301	1	Nut-Nyloc 3/8-16 Flg
9	112-7451	1	Screw-TAP

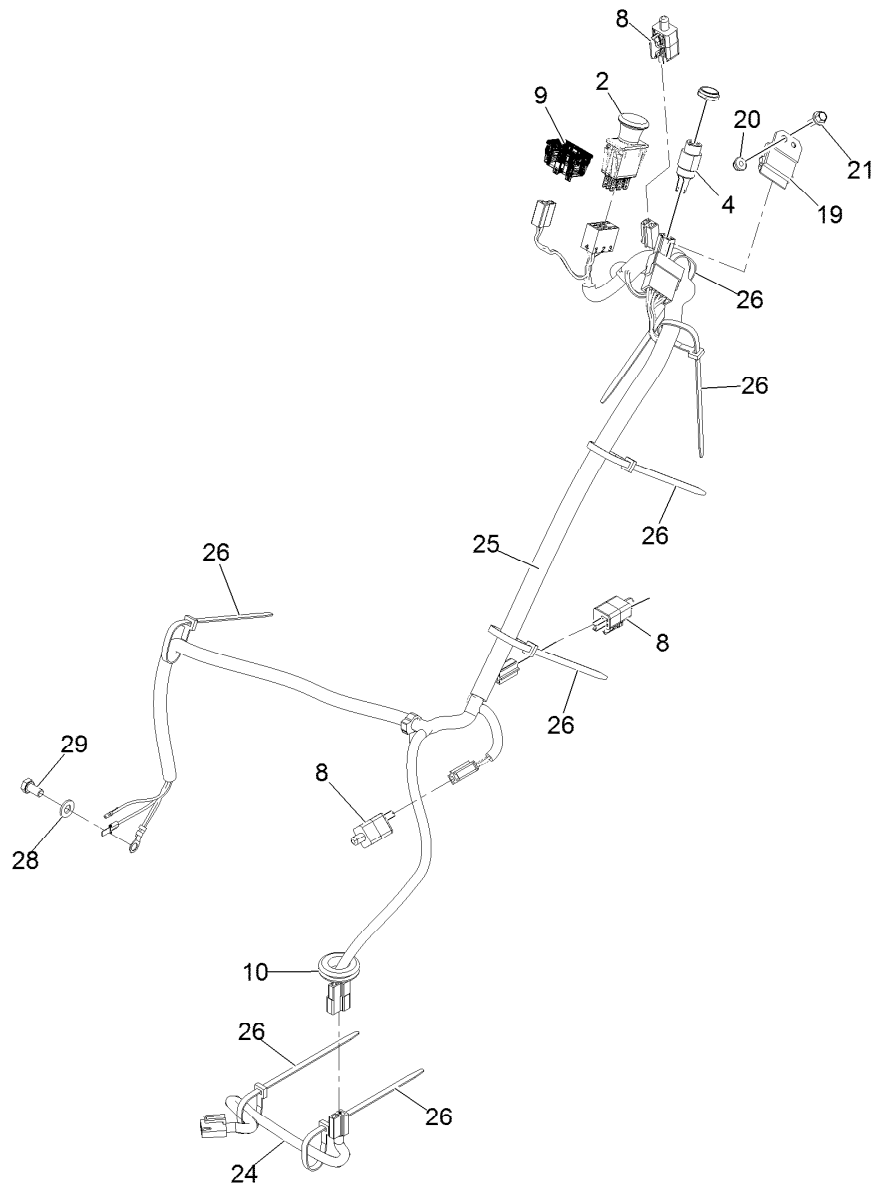

## Electrical Assembly

<b>Ref.</b>	<b>Part Number</b>	<b>Qty.</b>	<b>Description</b>
2	103-5221	1	Switch-PTO
4	1-403121	1	Switch & Key (Includes Nut & Washer)
4	103-0498	1	Nut-Ignition
8	110-6765	3	Switch
9	126-3931	1	Hour Meter
10	1-543286	1	Grommet
19	1-323430	1	Module-Interlock
20	104-7201	1	Nut-Nyloc 1/4-20 Flg
21	126-1592	1	Screw-Flange Head, 1/4-20 X .625
24	126-0624	1	Harness-Clutch Pigtail
25	126-0625	1	Harness-Main ●
26	1-303335	7	Tie-Cable 7 15/16 (Large)
28	33094-00	1	Washer
29	33114-016	1	Screw-HH M8-1.25 X 16Mm

● Use dielectric grease on all unsealed connectors and terminals only. Do not apply in sealed connectors.

**Notes:**

**Notes:**

# EXMARK® MAINTENANCE

## MAXIMIZE THE PERFORMANCE OF YOUR EXMARK.

### **4-CYCLE PREMIUM ENGINE OIL**

Part No. 116-3373

Both SAE 30 and SAE 10W-30 in one bottle.

Contains increased levels of zinc and phosphorus for better lubricity.

No Viscosity Index Improvers that tend to shear down in high heat.

Synthetic formulation.

Gas & Diesel compatible.

Anti-corrosion additives.

API 'SL' and JASO rated with wet clutch compatibility for other machines.

### **PREMIUM HYDRO OIL**

Part No. 109-9828

Commercial quality for tough, high-heat conditions.

Designed specifically for zero-turn mower hydraulic systems.

Superior shear resistance under heavy loads.

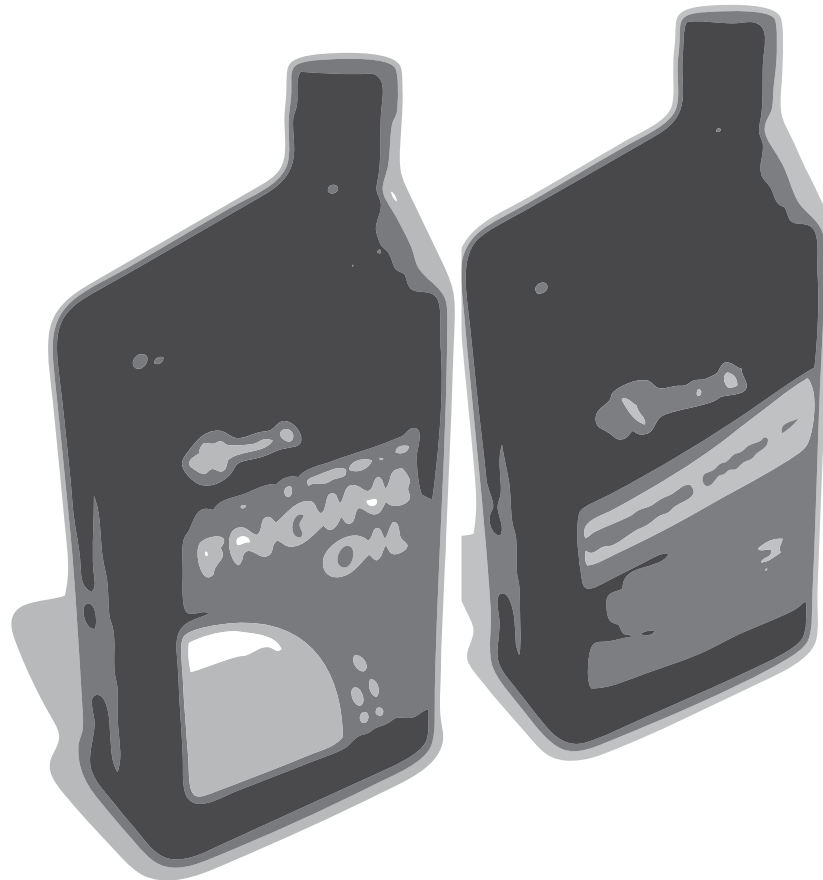

Available from your local Exmark dealer. Find your closest dealer at [exmark.com](http://exmark.com)

## EXMARK ACCESSORIES AND OPTIONS\*

### MID-MOUNT RIDING ACCESSORIES AND OPTIONS

CUSTOM RIDE SEAT SUSPENSION SYSTEM	OPERATOR CONTROLLED DISCHARGE
FULL SUSPENSION SEAT	SUN SHADE
DECK LIFT ASSIST KIT	TRASH CONTAINER
HITCH KIT	TURF STRIPER
LIGHT KIT	ULTRA VAC COLLECTION SYSTEM
12V POWER PORT	ULTRA VAC QUICK DISPOSAL SYSTEM
MICRO-MULCH SYSTEM	

### OUT-FRONT RIDING ACCESSORIES AND OPTIONS

CUSTOM RIDE SEAT SUSPENSION SYSTEM	SNOW BLADE
DUAL-TAIL WHEEL	SNOWBLOWER
FLOOR PAN EXTENDER	SUN SHADE
HITCH KIT	TRASH CONTAINER
LIGHT KIT	ULTRA VAC COLLECTION SYSTEM
MICRO-MULCH SYSTEM	ULTRA VAC QUICK DISPOSAL SYSTEM
ROLL OVER PROTECTION SYSTEM (ROPS)	WEATHER CAB

### WALK-BEHIND ACCESSORIES AND OPTIONS

GRASS CATCHER	TURF STRIPER
MICRO-MULCH SYSTEM	STANDON

\*Some accessories and options not available for some models.

Place Model No. and Serial No.  
Label Here (Included in the Literature  
Pack) or Fill in Below

Model No. \_\_\_\_\_

Serial No. \_\_\_\_\_

Date Purchased \_\_\_\_\_

Engine Model No. and Spec. No. \_\_\_\_\_

Engine Serial No. (E/No) \_\_\_\_\_

© 2015 Exmark Mfg. Co., Inc.  
Industrial Park Box 808  
Beatrice, NE 68310  
All Rights Reserved

Part No. 4501-942 Rev. B  
(402) 223-6300  
Fax (402) 223-5489  
Printed in the USA.

