

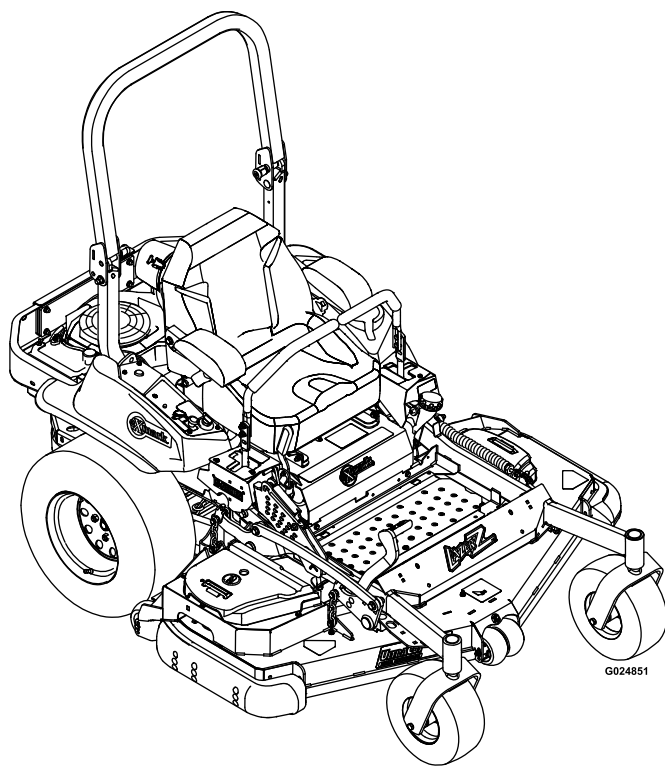

LAZER Z[®] S-SERIES

Model No. LZS740EKC60RD—Serial No. 31400000 and Up

Picture below may not reflect actual product.



Parts Manual

Ordering Replacement Parts

To order replacement parts, please supply the part number, the quantity, and the description of each part desired.

Understanding Reference Numbers

Each identified part in an illustration has a reference number. The reference number for a part also appears in the parts list, along with other information about the part.

This catalog uses two special reference number formats, one to indicate parts in a service assembly and another to indicate the quantity of a given part in an illustration.

Service Assembly Reference Numbers

Parts in service assemblies have reference numbers in the form a:b. The a represents the reference number of the entire service assembly and the b represents a sequential number unique to each part within the service assembly.

For example, a wheel assembly might be identified by reference number 6, the tire by 6:1, the valve by 6:2, and the wheel by 6:3. When you order the assembly identified by reference number 6, you receive all parts identified by reference numbers 6:1, 6:2, and 6:3. However, you may also order any part individually. Reference numbers of this type appear in illustration and in parts lists.

Reference Numbers Indicating Quantity

In an illustration, if a reference number indicates more than one part, the reference number has the form nX y. The n represents the quantity of the part, the X is the multiplication symbol, and the y represents the reference number.

For example, in an illustration, the reference number 2X 37 means that two of the parts identified by reference number 37 are indicated.

List of Abbreviations

| | | |
|--|--|--|
| AR: as required | HJ: hex jam | PRH: phillips round head |
| ASM: assembly | HLH: hex lag head | PTH: phillips truss head |
| BBC: blade brake control | HOC: height-of-cut | PTO: power-take-off |
| BHTF: button head thread forming | HSBH: hex socket button head | RH: right hand |
| CARR: carriage | HSFH: hex socket flat head | ROPS: roll-over protection system |
| CCW: counter clockwise | HSH: hex socket head | RRB: rear roller brush |
| CW: clockwise | HWH: hex washer head | SFH: slotted fillister head |
| DEG: degrees | HWHTF: hex washer head thread forming | SHH: slotted hex head |
| DPA: Dual Point Adjustment | HYD: hydraulic | SHWH: slotted hex washer head |
| ECM: electronic control module | LH: left hand | SPH: slotted pan head |
| EXT: external | LP: Liquefied Petroleum Gas | SQH: square head |
| FH: flat head | LPG: Liquefied Petroleum Gas | SRH: slotted round head |
| GA: gauge | NI: nylon insert | STD: standard |
| HD: heavy-duty | NPTF: national pipe thread fine | TAP: self tapping |
| HF: hex flange | PFH: phillips flat head | TTH: torx truss head |
| HH: hex head | PPH: phillips pan head | |
| HHF: hex head flange | PPHTF: phillips pan head thread forming | |
| HHFTF: hex head flange thread forming | | |

Touch Up Paint

Exmark black touch up spray paint – gloss black.

Exmark red touch up paint (spray paint – P/N 1-850337 - .6 oz liquid bottle – P/N 103-9140).



If your Exmark dealer does not have the Exmark part in stock, Exmark will get the parts to the dealer the next business day or the part will be FREE Guaranteed!! (Some restrictions apply. See your participating Exmark Dealer for details.)

Contents

| | |
|--|----|
| Complete Deck Assembly..... | 4 |
| Deck Assembly..... | 5 |
| Deck W/Decals No. 116-9839..... | 6 |
| Deck Idler Assembly No. 126-1720..... | 7 |
| Idler Assembly No. 126-0853..... | 8 |
| Main Frame Assembly..... | 9 |
| Roll-over Protection System Assembly No. 116-0230..... | 10 |
| Caster Wheel and Fork Assembly..... | 11 |
| Deck Lift Assembly..... | 12 |
| Discharge Tunnel Assembly No. 125-9362..... | 13 |
| Height-of-Cut Assembly No. 109-7438..... | 14 |
| Controls Assembly..... | 15 |
| Motion Control Assembly..... | 16 |
| Rear Wheel and Park Brake Assembly..... | 17 |
| Parking Brake Handle Assembly No. 116-7551..... | 18 |
| Seat Assembly..... | 19 |
| Seat W/Tracks Assembly No. 116-4474..... | 20 |
| Fuel Tank Mounting Assembly..... | 21 |
| Fuel Tank Assembly No. 116-3979..... | 22 |
| Engine Assembly..... | 23 |
| Hydraulic Assembly..... | 24 |
| LH Hydro Assembly No. 116-6413..... | 25 |
| RH Hydro Assembly No. 116-6414..... | 26 |
| Pump Idler Assembly No. 116-1255..... | 27 |
| Electrical Assembly..... | 28 |

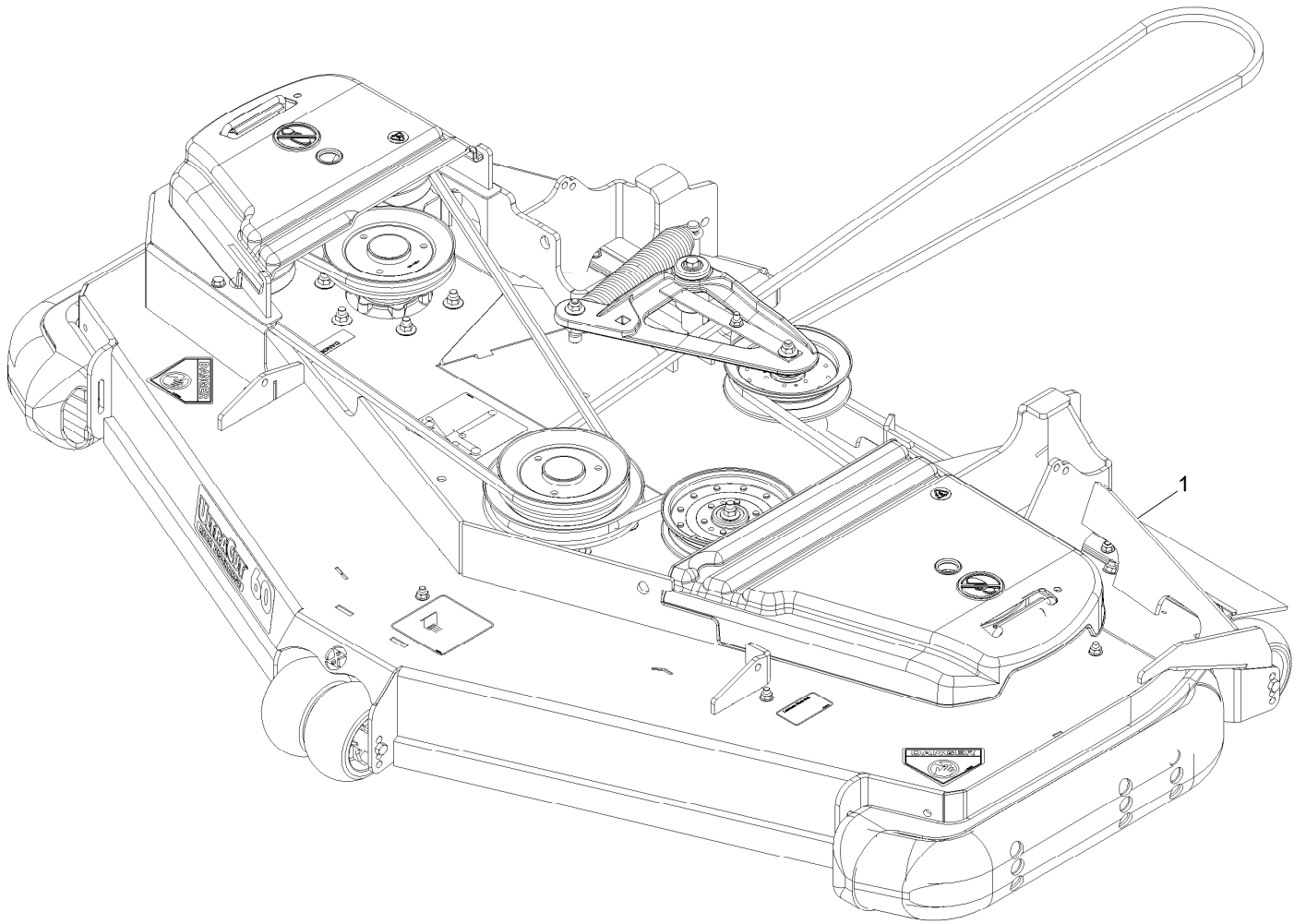

Complete Deck Assembly

| <i>Ref.</i> | <i>Part Number</i> | <i>Qty.</i> | <i>Description</i> |
|-------------|--------------------|-------------|----------------------------|
| 1 | 126-0376 | 1 | ASM-Deck Complete Rd60 NIz |

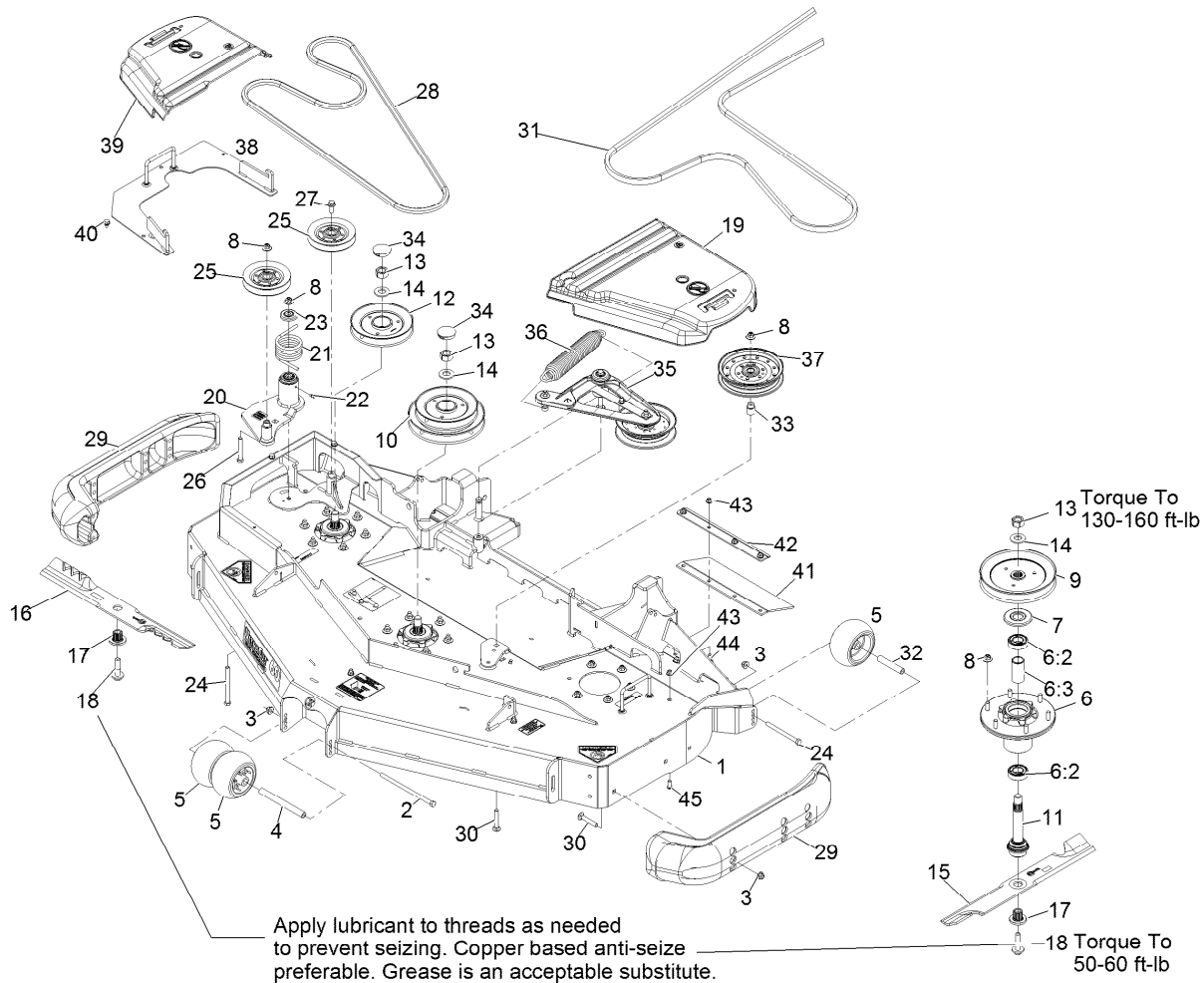

Deck Assembly

| Ref. | Part Number | Qty. | Description | Ref. | Part Number | Qty. | Description |
|------|-------------|------|--------------------------------|------|-------------|------|---------------------------------|
| 1 | 116-9839 | 1 | Deck-Rd60 Nlz, W/Decals | 20 | 126-0853 | 1 | Idler ASM |
| 2 | 108-5388 | 1 | Screw-HH | 21 | 108-1921 | 1 | Spring-Torsion |
| 3 | 104-8301 | 9 | Nut-Nyloc 3/8-16 Flg | 22 | 302-19 | 1 | Zerk-1/4-28 Str |
| 4 | 98-5967 | 1 | Spacer-Wheel | 23 | 103-2916 | 1 | Guard-Top |
| 5 | 1-603299 | 4 | Roller-Scalp, Anti | 24 | 323-23 | 3 | Screw-HH 3/8-16 X 4-1/2 |
| 6 | 116-3344 | 3 | ASM-Cutter Hsg With Bearings | 25 | 126-1478 | 2 | Sheave |
| 6:2 | 116-0720 | 2 | Bearing-Ball | 26 | 323-13 | 1 | Screw-HH 3/8-16 X 2 3/4 |
| 6:3 | 116-3312 | 1 | Spacer-Bearing | 27 | 3234-11 | 1 | Screw-HH Flg 3/8-16 X 1 |
| 7 | 116-1286 | 3 | Guard,Bearing Top .989 | 28 | 116-8187 | 1 | Belt-Hex |
| 8 | 109-6658 | 21 | Nut-Nyloc 3/8-16 Flg | 29 | 112-1479 | 2 | Skid-Bumper, Deck |
| 9 | 116-0676 | 1 | Sheave,Blade Drive 7.25 | 30 | 3231-7 | 7 | Bolt-Carriage 3/8-16 X 2 1/4 |
| 10 | 126-0352 | 1 | Jackshaft-Rev Drive 60Rd Ser 4 | 31 | 125-9371 | 1 | Belt-V |
| 11 | 116-3341 | 3 | ASM-Spindle And Seal | 32 | 98-7912 | 2 | Tube-Spanner |
| 12 | 126-0354 | 1 | Sheave-Rd Rev Drive Series 4 | 33 | 1-633456 | 1 | Bushing, Idler |
| 13 | 116-7306 | 3 | Nut-Hex | 34 | 116-2253 | 2 | Plug,Black Nylon 1.75 |
| 14 | 103-2802 | 3 | Washer-Spring Disc 3/4 | 35 | 126-1720 | 1 | Deck Idler ASM |
| 15 | 103-6388 | 2 | Blade, Low Lift | 36 | 116-6317 | 1 | Spring-Extension |
| 15 | 103-6403 | 2 | Blade, Notched | 37 | 116-4670 | 1 | Pulley-Idler, Flat |
| 15 | 116-5174 | 2 | Blade-Extreme 2, 20.50" | 38 | 116-8195-01 | 1 | Cover-Drive Reverse |
| 16 | 116-8196 | 1 | Blade-Low Lift 20.5, Rd60 | 39 | 116-8190 | 1 | Cover-Belt, RH |
| 16 | 116-8181 | 1 | Blade-Extreme 2-20.50, Rd60 | 40 | 9266934 | 3 | Screw-HWH 5/16 X 1/2 Tf |
| 17 | 103-3037 | 3 | Bushing, Splined | 41 | 116-8191 | 2 | Guard-Tire |
| 18 | 109-9220 | 3 | Screw-Sems 1/2-20 X 2.19 | 42 | 126-0413-01 | 2 | Support-Outer Flap |
| 19 | 109-6938 | 1 | Cover-Belt, LH | 43 | 104-8300 | 14 | Nut-Nyloc 5/16-18 Flg |
| | | | | 44 | 3230-16 | 8 | Bolt-Carriage 5/16-18 X 7/8 |
| | | | | 45 | 3274-55 | 6 | Screw-Button Head 5/16-18 X 3/4 |

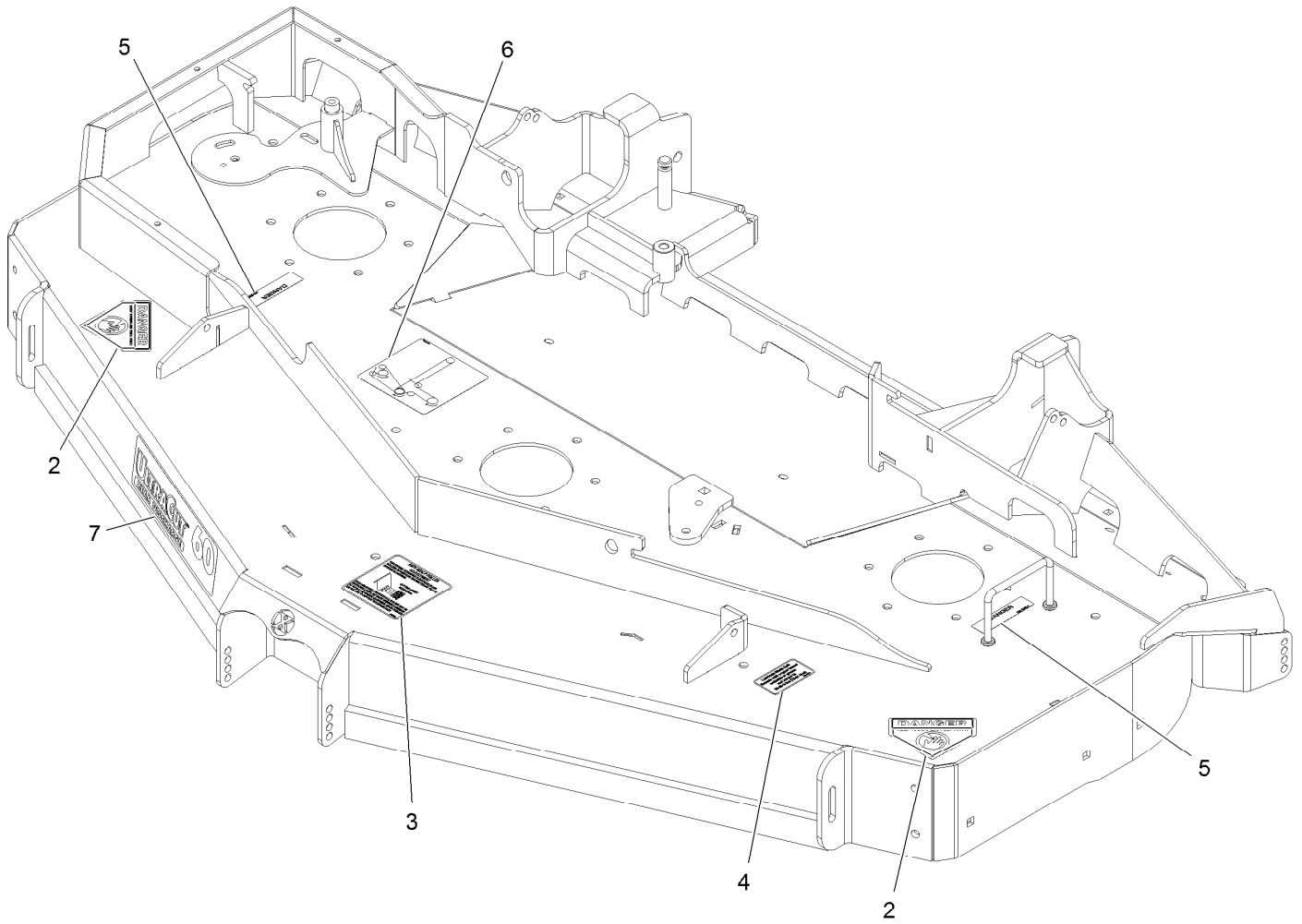

Deck W/Decals No. 116-9839

| <i>Ref.</i> | <i>Part Number</i> | <i>Qty.</i> | <i>Description</i> |
|-------------|--------------------|-------------|---------------------------|
| 2 | 1-403005 | 2 | Decal-Danger |
| 3 | 1-633922 | 1 | Decal, Anti-Scalp |
| 4 | 109-3148 | 1 | Decal, Bolt Torque |
| 5 | 98-5954 | 2 | Decal-Cover, Missing |
| 6 | 126-0768 | 1 | Decal-Belt Routing Nlz Rd |
| 7 | 116-8599 | 1 | Decal,Rear Discharge 60 |

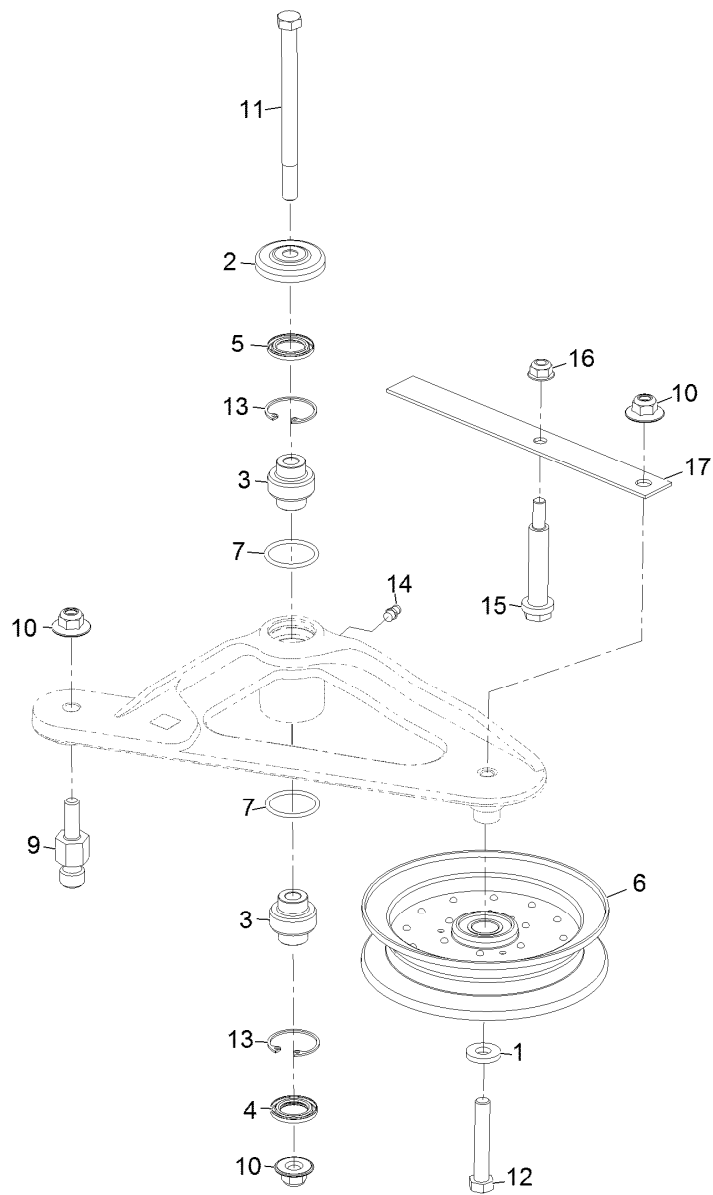

Deck Idler Assembly No. 126-1720

| <i>Ref.</i> | <i>Part Number</i> | <i>Qty.</i> | <i>Description</i> | <i>Ref.</i> | <i>Part Number</i> | <i>Qty.</i> | <i>Description</i> |
|-------------|--------------------|-------------|-----------------------|-------------|--------------------|-------------|-------------------------------------|
| 1 | 43-0940 | 1 | Spacer | 11 | 109-7409 | 1 | Screw-Shoulder 3/8-16 X 5 |
| 2 | 103-2916 | 1 | Guard-Top | 12 | 104-3396 | 1 | Screw-HH |
| 3 | 103-3504 | 2 | Bearing-Spherical | 13 | 32120-10 | 2 | Ring-Retaining |
| 4 | 103-3505 | 1 | Seal-Double Lip | 14 | 302-19 | 1 | Zerk-1/4-28 Str |
| 5 | 103-3506 | 1 | Seal-Single Lip | 15 | 88-4590 | 1 | Screw-Shoulder 5/16-18 X 1 29/32 |
| 6 | 116-4668 | 1 | Idler-Pulley, Flanged | 16 | 104-8300 | 1 | Nut-Nyloc 5/16-18 Flg |
| 7 | 106-7159 | 2 | O-Ring | 17 | 126-1704 | 1 | Spring-Belt Guide Leaf |
| 9 | 126-0423 | 1 | Pin-Spring, Anchor | | | | |
| 10 | 109-6658 | 2 | Nut-Nyloc 3/8-16 Flg | | | | |

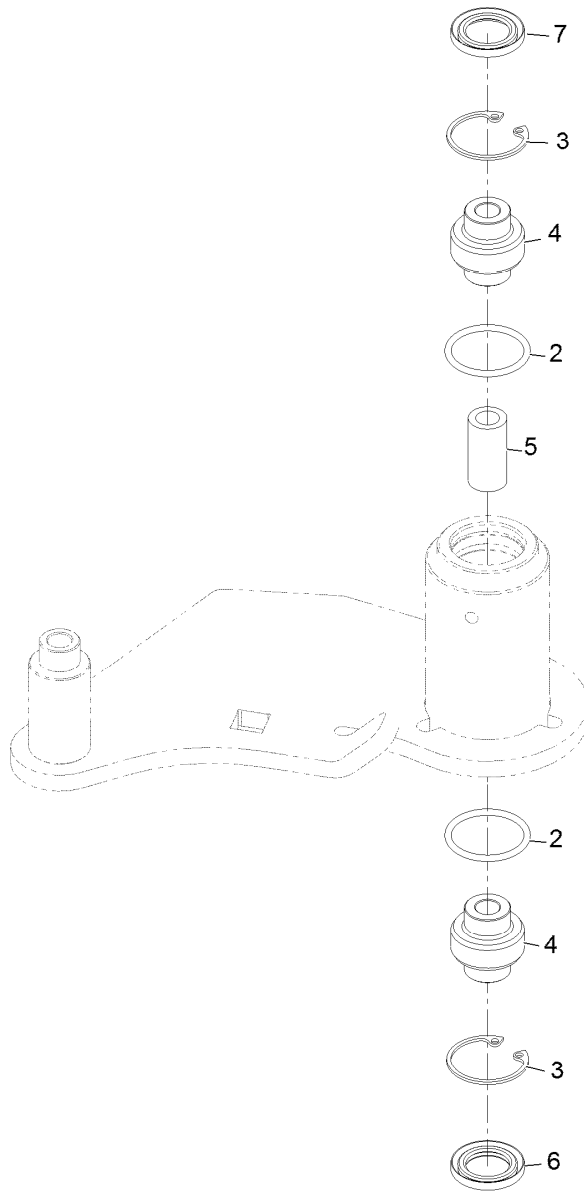

Idler Assembly No. 126-0853

| <i>Ref.</i> | <i>Part Number</i> | <i>Qty.</i> | <i>Description</i> |
|-------------|--------------------|-------------|--------------------|
| 2 | 106-7159 | 2 | O-Ring |
| 3 | 32120-10 | 2 | Ring-Retaining |
| 4 | 103-3504 | 2 | Bearing-Spherical |
| 5 | 108-6544 | 1 | Spacer |
| 6 | 103-3505 | 1 | Seal-Double Lip |
| 7 | 103-3506 | 1 | Seal-Single Lip |

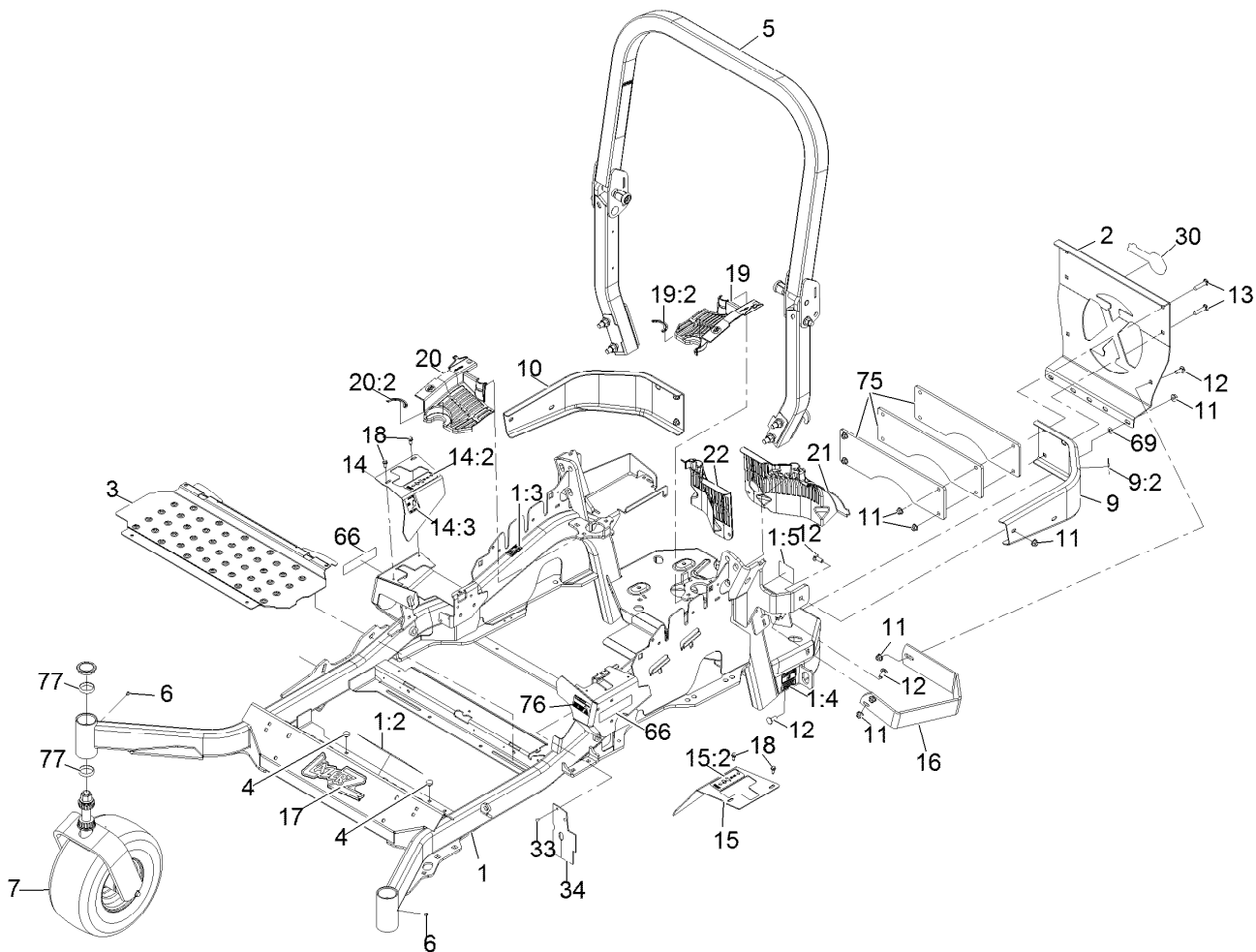

Main Frame Assembly

| Ref. | Part Number | Qty. | Description | Ref. | Part Number | Qty. | Description |
|------|-------------|------|------------------------------|------|-------------|------|-----------------------------|
| 1 | 116-9720 | 1 | Mainframe ASM | 15 | 116-0580 | 1 | LH Motion Control Cover ASM |
| 1:2 | 103-2076 | 2 | Decal-Caution | 15:2 | 109-7232 | 1 | Decal-Motion Control |
| 1:3 | 116-3303 | 1 | Decal-Slope | 16 | 126-2067-03 | 1 | Guard-Muffler |
| 1:4 | 116-0205 | 2 | Decal-Belt Drive | 17 | 103-3113 | 1 | Decal, Lazer Model |
| 1:5 | 116-4858 | 1 | Decal-Spark Arrester | 18 | 32144-10 | 4 | Screw-HWH 1/4-20 X .62 |
| 2 | 109-8863-03 | 1 | Plate,Rear Guard | 19 | 116-0170 | 1 | LH Hydro Guard ASM |
| 3 | 116-8898-01 | 1 | Floorpan | 19:2 | 116-0157 | 1 | Decal-Hydro Oil |
| 4 | 1-513658 | 2 | Bumper | 20 | 116-0171 | 1 | RH Hydro Guard ASM |
| 5 | 116-0230 | 1 | ASM,ROPS Service Exmark | 20:2 | 116-0157 | 1 | Decal-Hydro Oil |
| 6 | 1-811010 | 2 | Plug | 21 | 109-9057 | 1 | Guard-Hydro, Rear LH |
| 7 | | 2 | Caster Wheel ASM ● | 22 | 109-9058 | 1 | Guard-Hydro, Rear RH |
| 9 | 116-0180 | 1 | LH Bumper ASM | 30 | 103-2883 | 1 | Decal, Exmark Logo |
| 9:2 | 103-2076 | 1 | Decal-Caution | 33 | 1-803035 | 2 | Rivet 3/16 X 1/4 |
| 10 | 116-0057-03 | 1 | Bumper-RH | 34 | 116-2362 | 1 | Deflector-Air Flow |
| 11 | 104-8301 | 11 | Nut-Nyloc 3/8-16 Flg | 66 | 116-3884 | 2 | Decal-S-Series |
| 12 | 3231-22 | 7 | Bolt-Carriage 3/8-16 X 1 | 69 | 107-3154 | 2 | Nut-Push 3/8-16 |
| 13 | 3231-29 | 4 | Bolt-Carriage 3/8-16 X 1 3/4 | 75 | 126-2133-03 | 3 | Weight-Plate, 6 Lb |
| 14 | 116-5899 | 1 | RH Motion Control Cover ASM | 76 | 116-1654 | 1 | Decal-Fuel Fill |
| 14:2 | 109-7232 | 1 | Decal-Motion Control | 77 | 1-543508 | 4 | Cup-Bearing Tapered Roller |
| 14:3 | 116-5944 | 1 | Decal-Park Brake | | | | |

● Not serviced separately

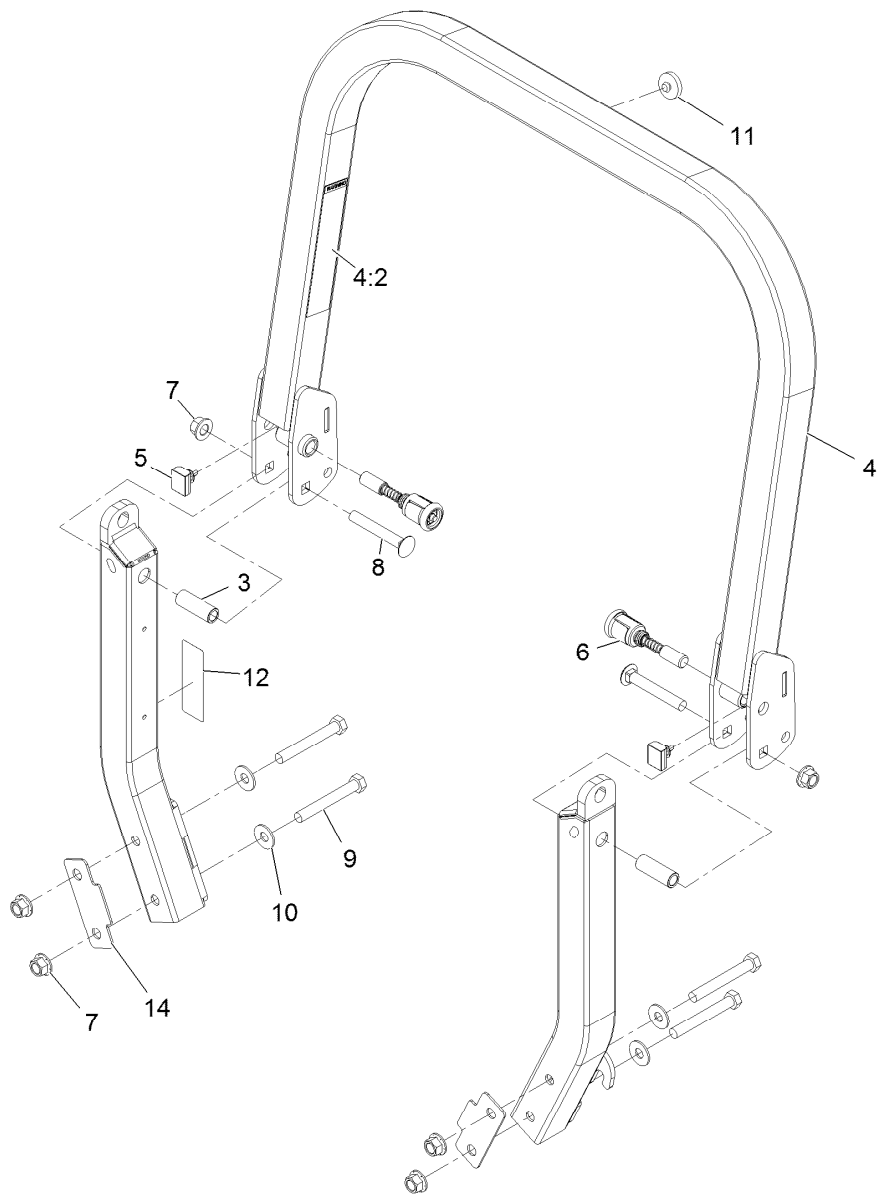

Roll-over Protection System Assembly No. 116-0230

| <i>Ref.</i> | <i>Part Number</i> | <i>Qty.</i> | <i>Description</i> |
|-------------|--------------------|-------------|------------------------------|
| 3 | 109-6653 | 2 | Spacer |
| 4 | 116-0019 | 1 | Upper ROPS ASM |
| 4:2 | 107-2102 | 1 | Decal-Warning, Folding ROPS |
| 5 | 109-5337 | 2 | Bumper-ROPS |
| 6 | 116-0104 | 2 | Pin-Spring |
| 7 | 99-5107 | 6 | Nut-Lock 1/2-13 |
| 8 | 3233-10 | 2 | Bolt-Carriage 1/2-13 X 3 1/2 |
| 9 | 325-35 | 4 | Screw-HH |
| 10 | 109-9505 | 4 | Washer, Spring Disc 1/2 |
| 11 | 109-9233 | 1 | Bumper-Push-In, Rubber |
| 12 | 116-0090 | 1 | Decal-Caution |
| 14 | 116-0960 | 2 | Spacer |

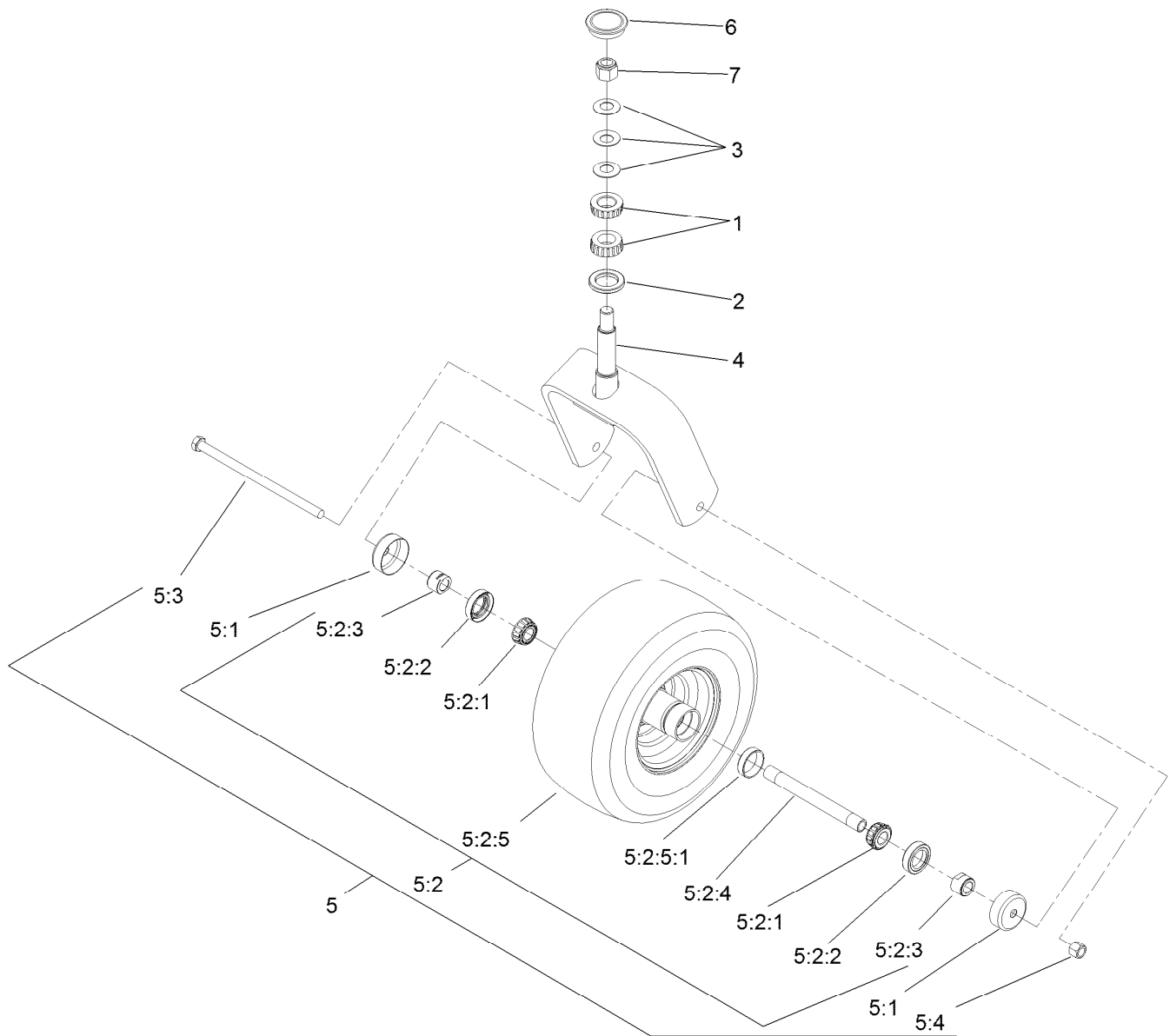

Caster Wheel and Fork Assembly

| Ref. | Part Number | Qty. | Description | Ref. | Part Number | Qty. | Description |
|-------|-------------|------|-------------------------|---------|-------------|------|----------------------|
| 1 | 1-543509 | 2 | Bearing-Roller, Tapered | 5:2:3 | 103-3051 | 2 | Spacer-Nut ■ |
| 2 | 116-5647 | 1 | Seal-Grease | 5:2:4 | 103-5156 | 1 | Axle-Caster |
| 3 | 1-633508 | 3 | Washer-Bellville | 5:2:5 | | 1 | Wheel And Tire ASM ● |
| 4 | 116-6707-01 | 1 | Caster | 5:2:5:1 | 1-633584 | 1 | Bearing-Cup |
| 5 | 109-9127 | 1 | Wheel And Tire ASM | 5:3 | 325-39 | 1 | Screw-HH |
| 5:1 | 103-2768 | 2 | Guard-Seal | 5:4 | 3296-23 | 1 | Nut-Lock, NI |
| 5:2 | | 1 | Wheel And Tire ASM ● | 6 | 103-4882 | 1 | Cap-Grease |
| 5:2:1 | 1-633585 | 2 | Bearing-Cone, Taper | 7 | 3296-51 | 1 | Nut-Lock, NI |
| 5:2:2 | 103-0063 | 2 | Seal-Caster | | | | |

● Not serviced separately

■ Use Pro-Lock, Nut Type (P/N 1-840022, .5ml tube) on threads.

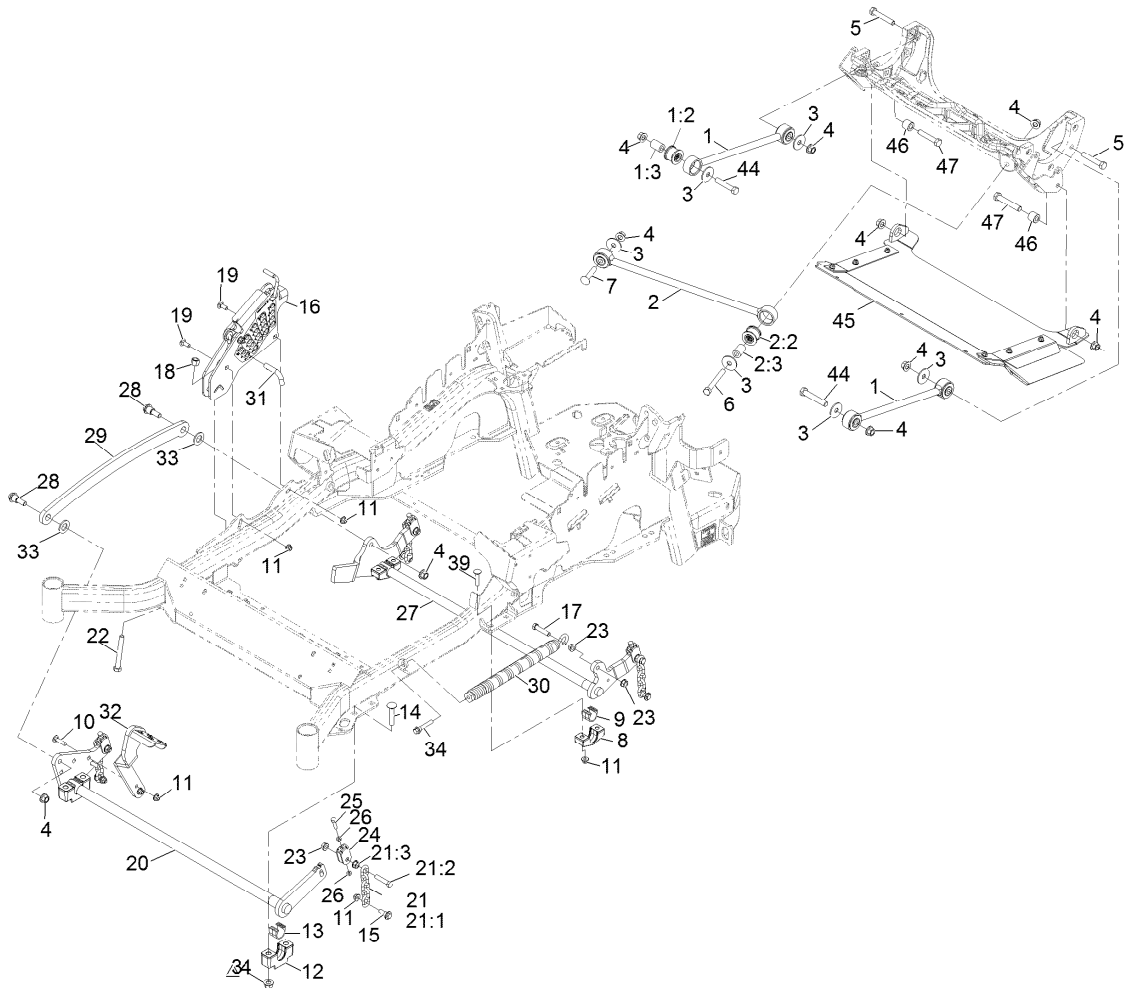

Deck Lift Assembly

| Ref. | Part Number | Qty. | Description | Ref. | Part Number | Qty. | Description |
|------|-------------|------|---------------------------------------|------|-------------|------|----------------------------------|
| 1 | 109-7952 | 2 | Deck Strut ASM | 18 | 3296-23 | 1 | Nut-Nyloc 1/2-13 |
| 1:2 | 109-5009 | 2 | Bushing-Suspension, Rubber | 19 | 3231-2 | 2 | Bolt-Carriage 3/8-16 X 1 |
| 1:3 | 109-5010 | 2 | Spacer | 20 | 126-2475-03 | 1 | Decklift-Front |
| 2 | 109-5013 | 1 | Panhard Rod ASM | 21 | 116-0756 | 4 | Deck Lift Chain ASM |
| 2:2 | 109-5009 | 2 | Bushing-Suspension, Rubber | 21:1 | 1-633447 | 1 | Chain-Lift, Deck |
| 2:3 | 109-5010 | 2 | Spacer | 21:2 | 109-9065 | 1 | Screw-HH 7/16-14 X 2 |
| 3 | 86-1990 | 6 | Washer | 21:3 | 32128-37 | 1 | Nut-Whizlock 7/16-14 |
| 4 | 99-5107 | 14 | Nut-Lock 1/2-13 | 22 | 116-0559 | 1 | Bolt-HH 1/2-13 X 4 Tap |
| 5 | 325-12 | 2 | Screw-HH 1/2-13 X 3 | 23 | 32128-37 | 6 | Nut-Whizlock 7/16-14 |
| 6 | 325-17 | 1 | Screw-HH 1/2-13 X 4 | 24 | 109-9066 | 4 | Yoke-Adjust, Deck |
| 7 | 3233-34 | 1 | Bolt-Carriage 1/2-13 X 2 1/2 | 25 | 322-47 | 4 | Screw-HH 5/16-18 X 1 1/4 |
| 8 | 116-0818-03 | 2 | Support-Cross Shaft, Rear Bearing | 26 | 3218-2 | 8 | Nut-Jam 5/16-18 |
| 9 | 109-7173 | 2 | Bearing-Cross Shaft, Rear | 27 | 116-0459-03 | 1 | Lift-Deck, Rear |
| 10 | 3231-4 | 2 | Bolt-Carriage 3/8-16 X 1 1/2 | 28 | 116-0780 | 2 | Screw-Shoulder HHF 1/2-13 X 1.12 |
| 11 | 104-8301 | 12 | Nut-Nyloc 3/8-16 Flg | 29 | 116-0797-03 | 1 | Link-Lift, Deck |
| 12 | 109-9409 | 2 | Support-Cross Shaft, Front Bearing | 30 | 116-0000 | 1 | Extension Spring ASM |
| 13 | 109-9410 | 2 | Bearing-Cross Shaft, Front | 31 | 116-5584 | 1 | Pin-HOC |
| 14 | 116-1700 | 4 | Bolt-Carriage 1/2-13 X 2 1/2 Spl Neck | 32 | 116-1919-01 | 1 | Lever-Foot |
| 15 | 109-9840 | 4 | Screw-Hex Flange 3/8-16 X .80 | 33 | 3256-28 | 2 | Washer-3/4 Sae |
| 16 | 109-7438 | 1 | HOC ASM | 34 | 92-7674 | 1 | Screw-Shcs 3/8-16 X 2.212 |
| 17 | 109-9065 | 1 | Screw-HH 7/16-14 X 2 | 39 | 3231-5 | 4 | Bolt-Carriage 3/8-16 X 1 3/4 |
| | | | | 44 | 325-11 | 2 | Screw-HH 1/2-13 X 2 3/4 |
| | | | | 45 | 125-9362 | 1 | Discharge Tunnel ASM |
| | | | | 46 | 126-1705 | 2 | Bushing-Sleeve |
| | | | | 47 | 325-9 | 2 | Screw-HH 1/2-13 X 2 1/4 |

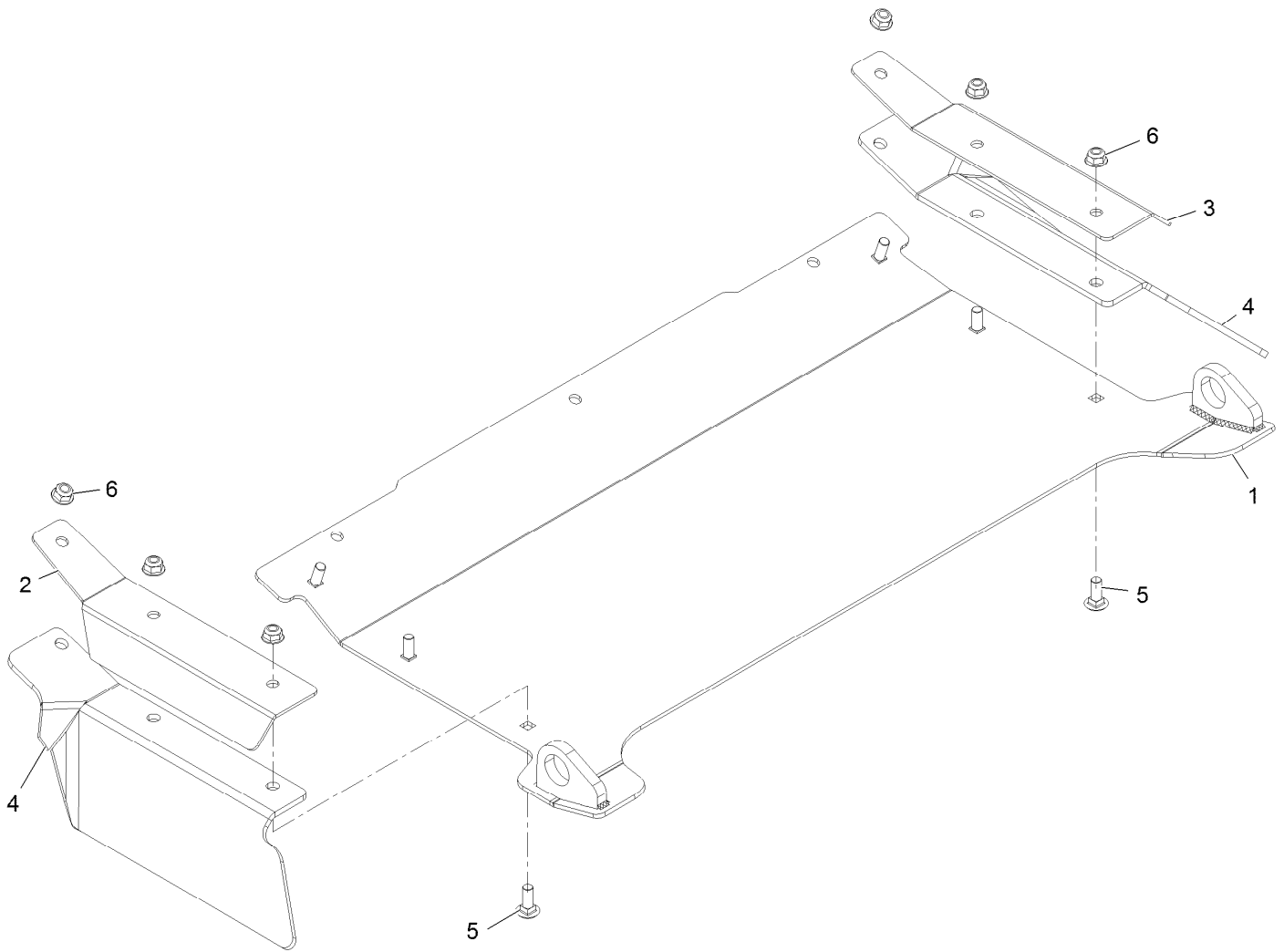

Discharge Tunnel Assembly No. 125-9362

| <i>Ref.</i> | <i>Part Number</i> | <i>Qty.</i> | <i>Description</i> |
|-------------|--------------------|-------------|-----------------------------|
| 1 | 125-9363-03 | 1 | Tunnel-Discharge |
| 2 | 125-9366-03 | 1 | Bracket-Flap, LH |
| 3 | 125-9367-03 | 1 | Bracket-Flap, RH |
| 4 | 125-9368 | 2 | Flap-Rubber |
| 5 | 3230-16 | 6 | Bolt-Carriage 5/16-18 X 7/8 |
| 6 | 104-8300 | 6 | Nut-Nyloc 5/16-18 Fig |

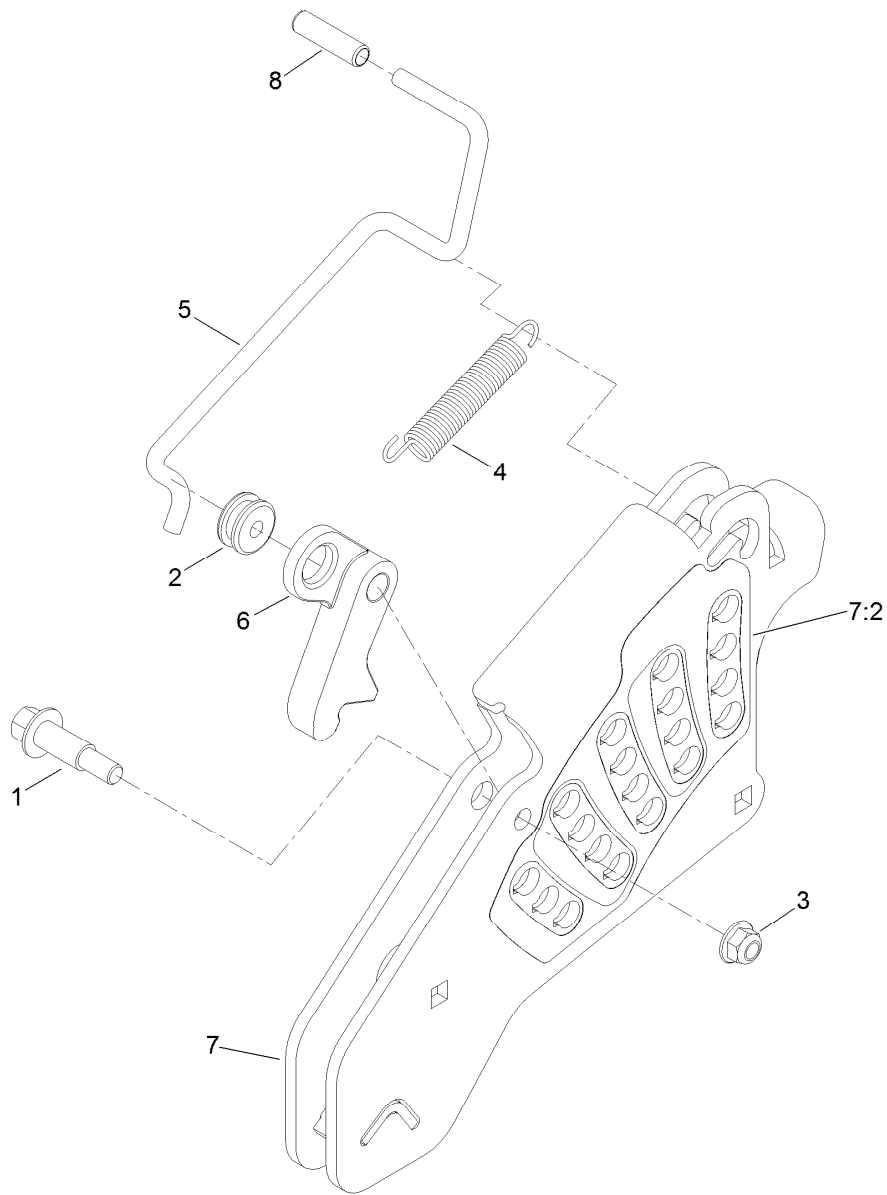

Height-of-Cut Assembly No. 109-7438

| <i>Ref.</i> | <i>Part Number</i> | <i>Qty.</i> | <i>Description</i> |
|-------------|--------------------|-------------|---------------------|
| 1 | 62-1330 | 1 | Bolt-Shoulder |
| 2 | 109-7130 | 1 | Grommet |
| 3 | 104-8301 | 1 | Nut-Flange, NI |
| 4 | 109-7124 | 1 | Spring-Extension |
| 5 | 109-7128 | 1 | Rod-Lock, Transport |
| 6 | 116-0118 | 1 | Pawl-Transport, HOC |
| 7 | 109-7335 | 1 | HOC Plate ASM |
| 7:2 | 116-0752 | 1 | Decal-HOC |
| 8 | 109-8250 | 1 | Grip-Lever |

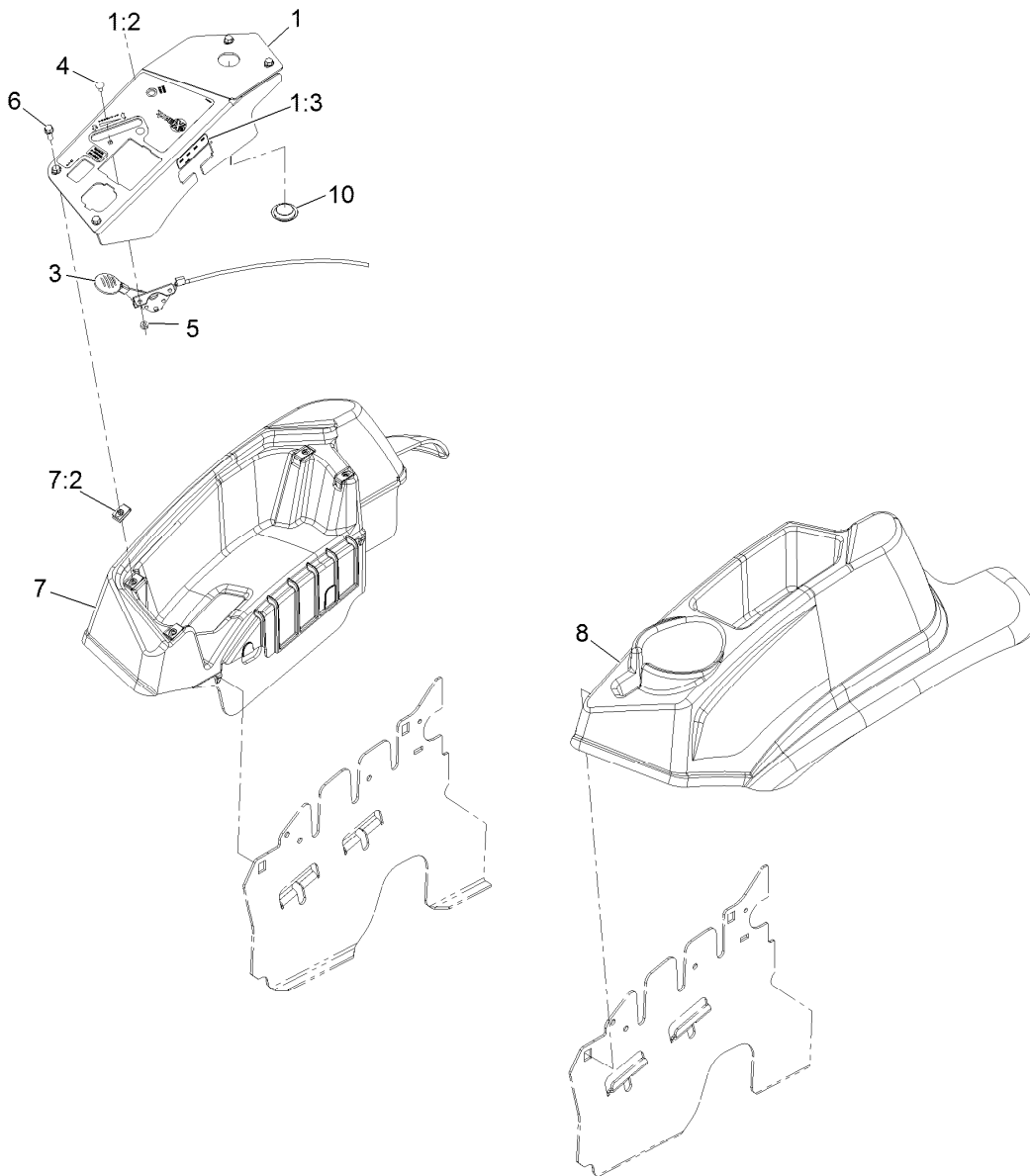

Controls Assembly

| <i>Ref.</i> | <i>Part Number</i> | <i>Qty.</i> | <i>Description</i> |
|-------------|--------------------|-------------|----------------------------|
| 1 | 116-2845 | 1 | ASM,Control Panel W/Decal |
| 1:2 | 116-2844 | 1 | Decal,Control Panel Efi |
| 1:3 | 109-7330 | 1 | Decal-Fuse |
| 3 | 116-0969 | 1 | ASM,Throttle Cable |
| 4 | 1-807513 | 2 | Bolt-Carriage #10-24 X 1/2 |
| 5 | 3296-2 | 2 | Nut-Nyloc #10-24 |
| 6 | 32105-15 | 4 | Screw-Machine 1/4-20 X 3/4 |
| 7 | 116-1278 | 1 | Console,RH As ASM |
| 7:2 | 107069 | 4 | Nut-Retainer-Panel 1/4-20 |
| 8 | 109-9457 | 1 | Console, LH As |
| 10 | 116-1875 | 1 | Plug,Plastic |

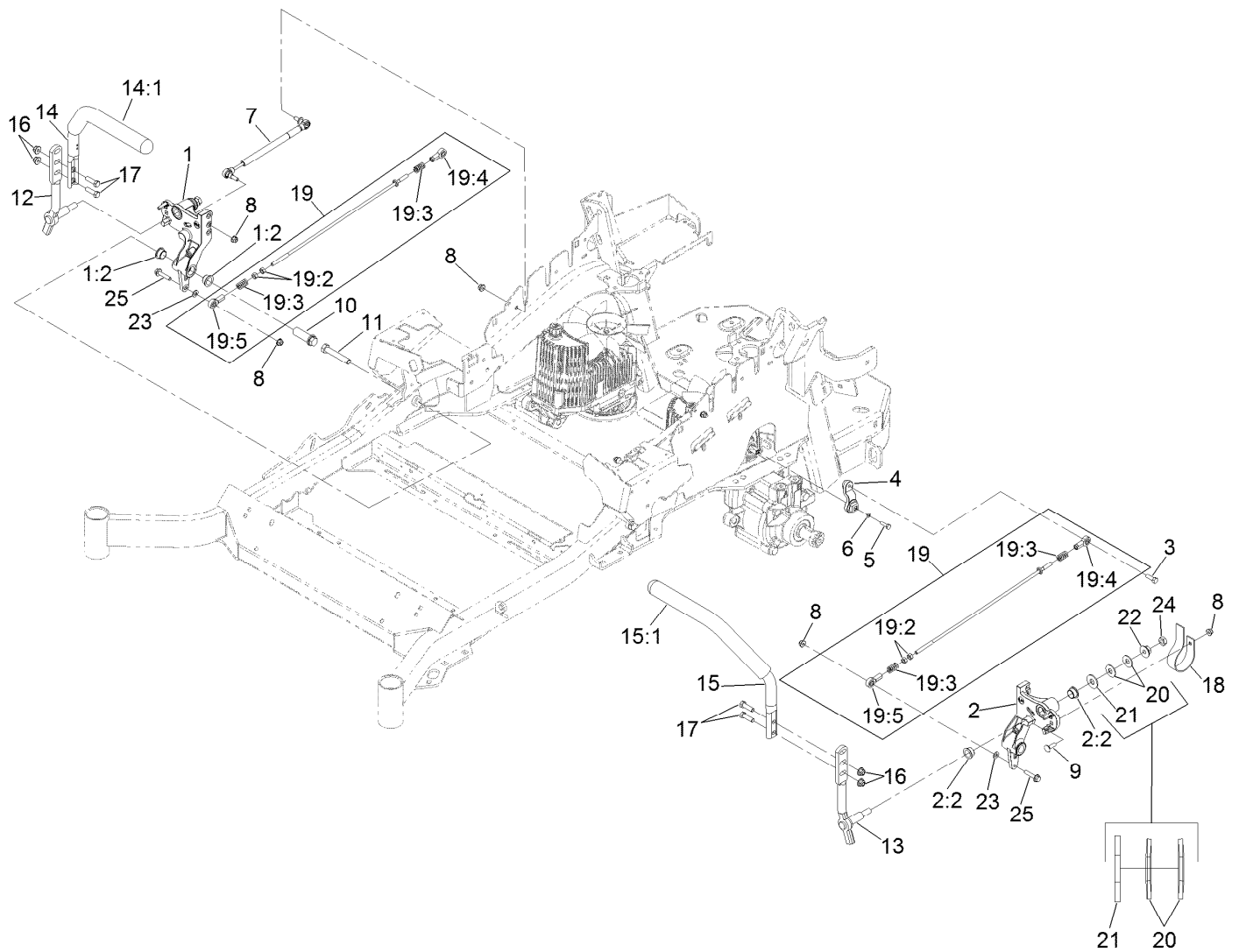

Motion Control Assembly

| Ref. | Part Number | Qty. | Description | Ref. | Part Number | Qty. | Description |
|------|-------------|------|-----------------------------------|------|-------------|------|------------------------|
| 1 | 116-0880 | 1 | RH Motion Control And Bushing ASM | 14 | 109-6589 | 1 | RH Steering Handle ASM |
| 1:2 | 109-8054 | 4 | Bushing-Flange | 14:1 | 109-5668 | 1 | Grip-Control, Lever |
| 2 | 116-0881 | 1 | LH Motion Control And Bushing ASM | 15 | 109-6590 | 1 | LH Steering Handle ASM |
| 2:2 | 109-8054 | 4 | Bushing-Flange | 15:1 | 109-5668 | 1 | Grip-Control, Lever |
| 3 | 116-0648 | 2 | Screw-HH, Thread Locking ● | 16 | 104-8301 | 4 | Nut-Flange, NI |
| 4 | 109-4581 | 2 | Arm-Control, Pump | 17 | 323-7 | 4 | Screw-HH |
| 5 | 9080046 | 2 | Screw-HH ● | 18 | 109-5575 | 2 | Spring-Leaf |
| 6 | 1-303435 | 2 | Washer-Spring | 19 | 109-8107 | 2 | Pump Linkage Rear ASM |
| 7 | 116-0027 | 2 | Damper-Control, Motion | 19:2 | 3219-2 | 2 | Nut-Hex |
| 8 | 104-8300 | 8 | Nut-Flange, NI | 19:3 | 1-323245 | 2 | Spring-Compression |
| 9 | 3230-2 | 2 | Bolt-CARR | 19:4 | 1-633152 | 1 | Balljoint-LH |
| 10 | 109-5891 | 2 | Hub-Threaded | 19:5 | 1-543017 | 1 | Balljoint-RH |
| 11 | 325-12 | 2 | Screw-HH | 20 | 109-9505 | 4 | Washer-Spring |
| 12 | 116-0039 | 1 | Lever-Control Motion, RH | 21 | 3256-6 | 2 | Washer-Flat |
| 13 | 116-0040 | 1 | Lever-Control Motion, LH | 22 | 32128-56 | 2 | Nut-HF |
| | | | | 23 | 3256-23 | 2 | Washer-Flat |
| | | | | 24 | 3218-5 | 2 | Nut-Jam |
| | | | | 25 | 115-1794 | 2 | Screw-HHF |

● Use Pro-Lock, Nut Type (P/N 1-840022, .5ml tube) on threads.

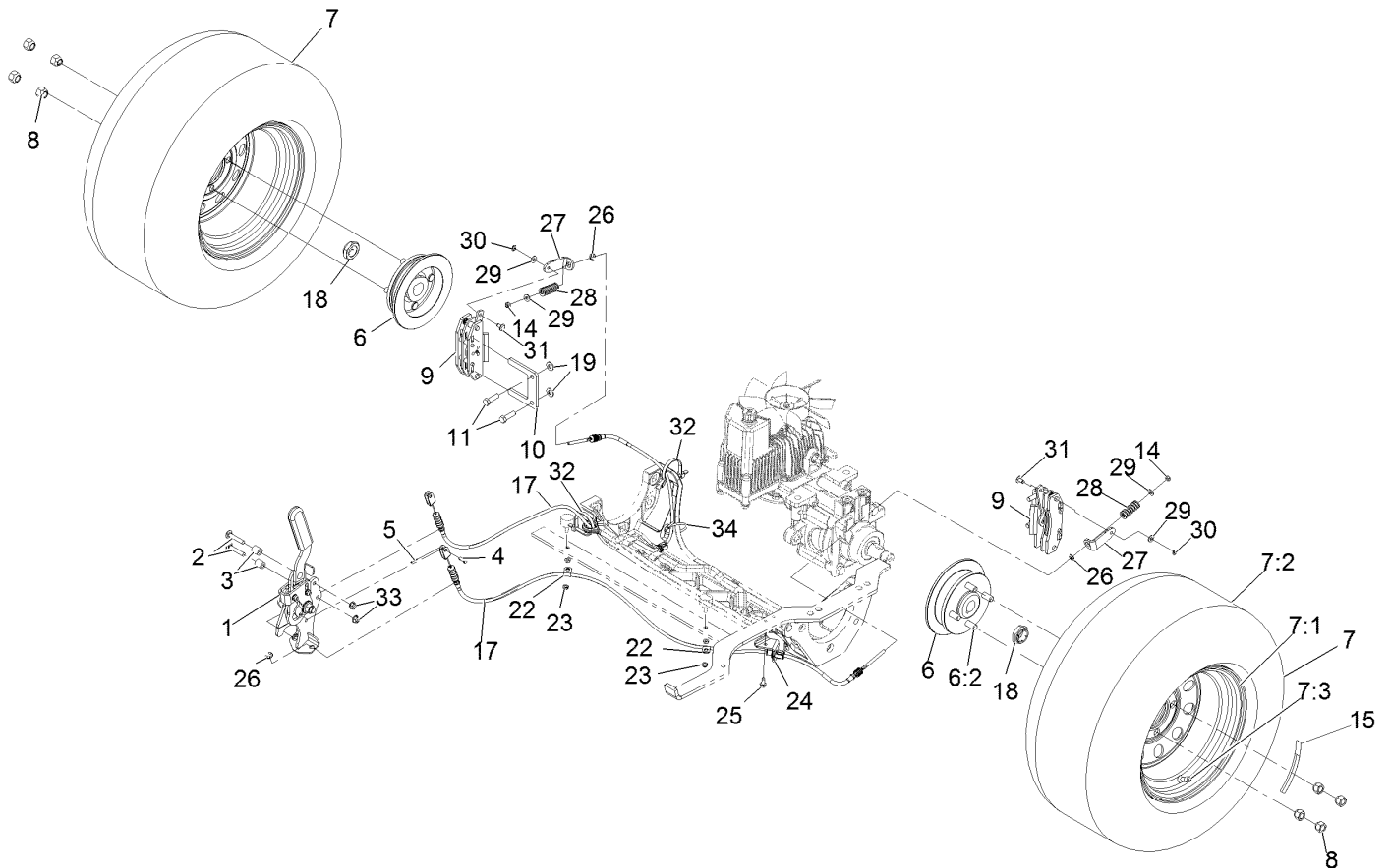

Rear Wheel and Park Brake Assembly

| Ref. | Part Number | Qty. | Description | Ref. | Part Number | Qty. | Description |
|------|-------------|------|--------------------------------------|------|-------------|------|----------------------------|
| 1 | 116-7551 | 1 | Brake Handle ASM | 15 | 126-2055 | 2 | Decal-Torque Wheel Lug-Hub |
| 2 | 116-0629 | 2 | Screw-Carriage 5/16-18 X 1 3/4 Short | 17 | 116-8963 | 2 | Cable-Brake |
| 3 | 82-6840 | 2 | Spacer | 18 | 116-1399 | 2 | Locknut |
| 4 | 60-1730 | 2 | Pin-Clevis | 19 | 3256-24 | 4 | Washer-3/8 Sae |
| 5 | 3272-1 | 2 | Pin-Cotter 1/16 X 1/2 | 22 | 88-7970 | 2 | Clip |
| 6 | 116-1746 | 2 | Wheel Hub ASM | 23 | 3296-56 | 2 | Nut-Nyloc 1/4-20 Thin |
| 6:2 | 116-1696 | 4 | Stud-Wheel | 24 | 116-6397 | 1 | Bracket-Cable |
| 7 | 115-3588 | 2 | Wheel And Tire ASM | 25 | 32144-10 | 1 | Screw-HWH 1/4-20 X .62 |
| 7:1 | 109-2871 | 1 | Rim | 26 | 32120-18 | 4 | E-Ring |
| 7:2 | 1-633993 | 1 | Tire | 27 | 116-6182 | 2 | Bracket-Brake, L |
| 7:3 | 232-27 | 1 | Stem-Valve | 28 | 116-6347 | 2 | Spring-Die |
| 8 | 242-50 | 8 | Nut-Lug 1/2-20 | 29 | 3256-22 | 4 | Washer-1/4 Sae |
| 9 | 109-2889 | 2 | Caliper-Brake | 30 | 32151-86 | 2 | E-Ring |
| 10 | 109-0958 | 2 | Plate-Mount, Brake | 31 | 116-6348 | 2 | Pin-Brake |
| 11 | 92-5727 | 4 | Screw-HH 3/8-16 X 1 1/4 Patch Lock | 32 | 3334-945 | 2 | Tie-Cable |
| 14 | 3296-13 | 2 | Nut-Nyloc 1/4-28 | 33 | 104-8300 | 2 | Nut-Nyloc 5/16-18 Flg |
| | | | | 34 | 116-0940 | 1 | Tie-Cable |

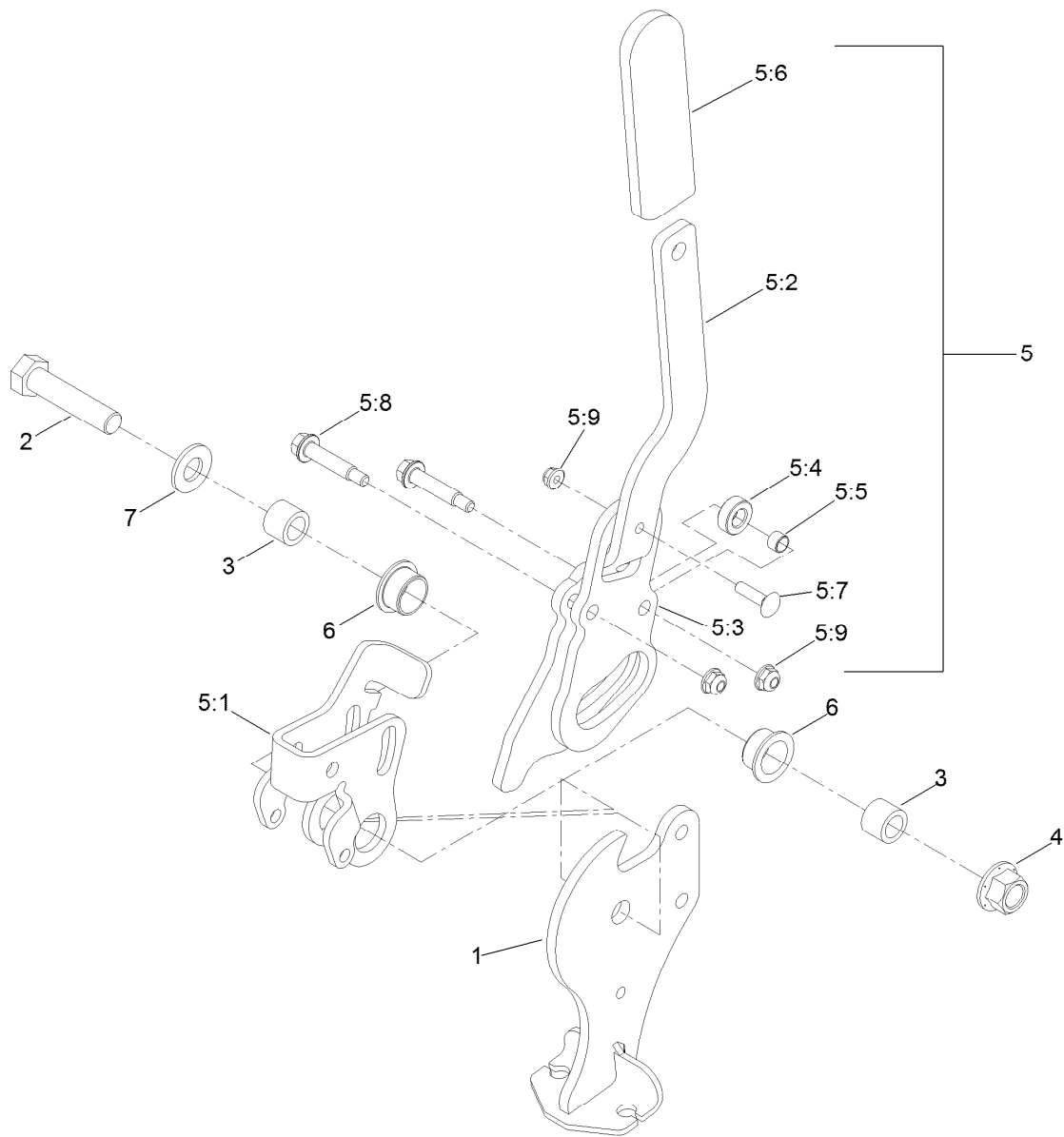

Parking Brake Handle Assembly No. 116-7551

| <i>Ref.</i> | <i>Part Number</i> | <i>Qty.</i> | <i>Description</i> | <i>Ref.</i> | <i>Part Number</i> | <i>Qty.</i> | <i>Description</i> |
|-------------|--------------------|-------------|-------------------------|-------------|--------------------|-------------|--------------------------|
| 1 | 116-7263 | 1 | Pivot-Brake | 5:4 | 116-6846 | 1 | Roller-Brake |
| 2 | 325-9 | 1 | Screw-HH 1/2-13 X 2 1/4 | 5:5 | 116-6852 | 1 | Bearing-Sleeve |
| 3 | 116-5384 | 2 | Spacer | 5:6 | 1-633268 | 1 | Grip-Lever |
| 4 | 99-5107 | 1 | Nut-Lock 1/2-13 | 5:7 | 3229-2 | 1 | Bolt-Carriage 1/4-20 X 1 |
| 5 | 116-6860 | 1 | Handle ASM | 5:8 | 116-6876 | 2 | Screw-Shoulder |
| 5:1 | 116-6856 | 1 | Bellcrank-Brake | 5:9 | 104-7201 | 3 | Nut-Nyloc 1/4-20 Flg |
| 5:2 | 116-6857 | 1 | Handle-Brake | 6 | 109-8054 | 2 | Bushing-Flanged |
| 5:3 | 116-6858 | 1 | Plate-Handle | 7 | 3256-26 | 1 | Washer-1/2 Sae |

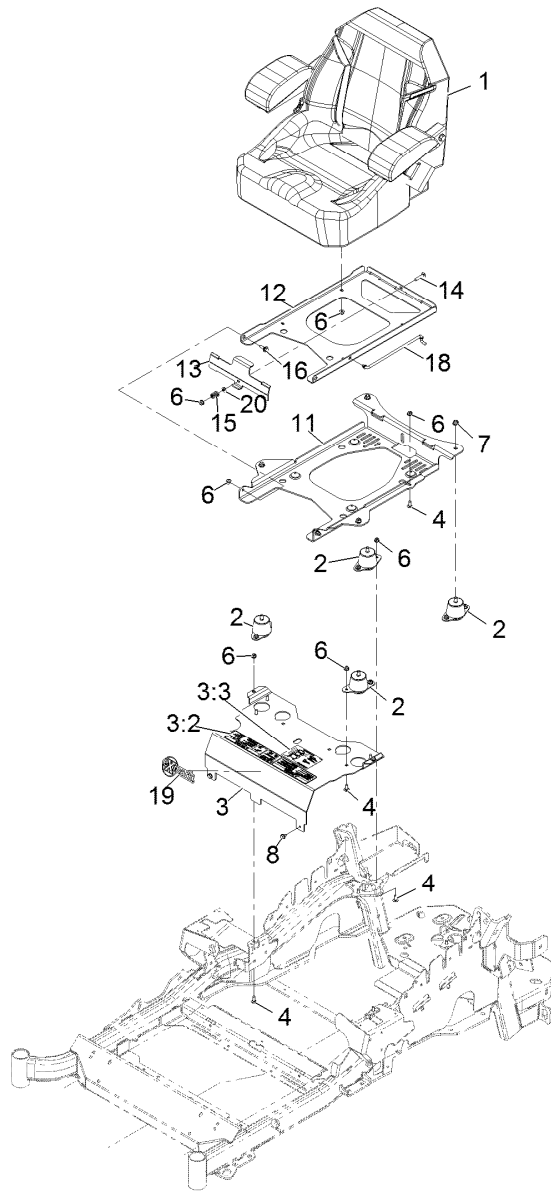

Seat Assembly

| <i>Ref.</i> | <i>Part Number</i> | <i>Qty.</i> | <i>Description</i> | <i>Ref.</i> | <i>Part Number</i> | <i>Qty.</i> | <i>Description</i> |
|-------------|--------------------|-------------|--|-------------|--------------------|-------------|-------------------------------|
| 1 | 116-4474 | 1 | Seat,Exmark Standard Service | 11 | 116-3860-03 | 1 | Plate-Tilt, Seat Support |
| 2 | 109-9034 | 4 | Isolator-Seat | 12 | 116-3859-03 | 1 | Plate-Seat, Frame |
| 3 | 116-2323 | 1 | Mount-Seat | 13 | 109-9881-03 | 1 | Plate-Latch, Seat |
| 3:2 | 109-7069 | 1 | Decal-Console | 14 | 3230-4 | 1 | Bolt-Carriage 5/16-18 X 1 1/2 |
| 3:3 | 116-0211 | 1 | Decal-Service Aid | 15 | 107-3017 | 1 | Spring-Compression |
| 4 | 3230-23 | 11 | Bolt-Carriage 5/16-18 X 3/4 Short Neck | 16 | 116-1297 | 2 | Screw-Shoulder |
| 6 | 104-8300 | 18 | Nut-Nyloc 5/16-18 Flg | 18 | 116-0070 | 1 | Rod-Prop |
| 7 | 104-8301 | 4 | Nut-Nyloc 3/8-16 Flg | 19 | 103-2883 | 1 | Decal, Exmark Logo |
| 8 | 9266934 | 2 | Screw-HWH 5/16 X 1/2 Tf | 20 | 3256-23 | 1 | Washer-5/16 Sae |

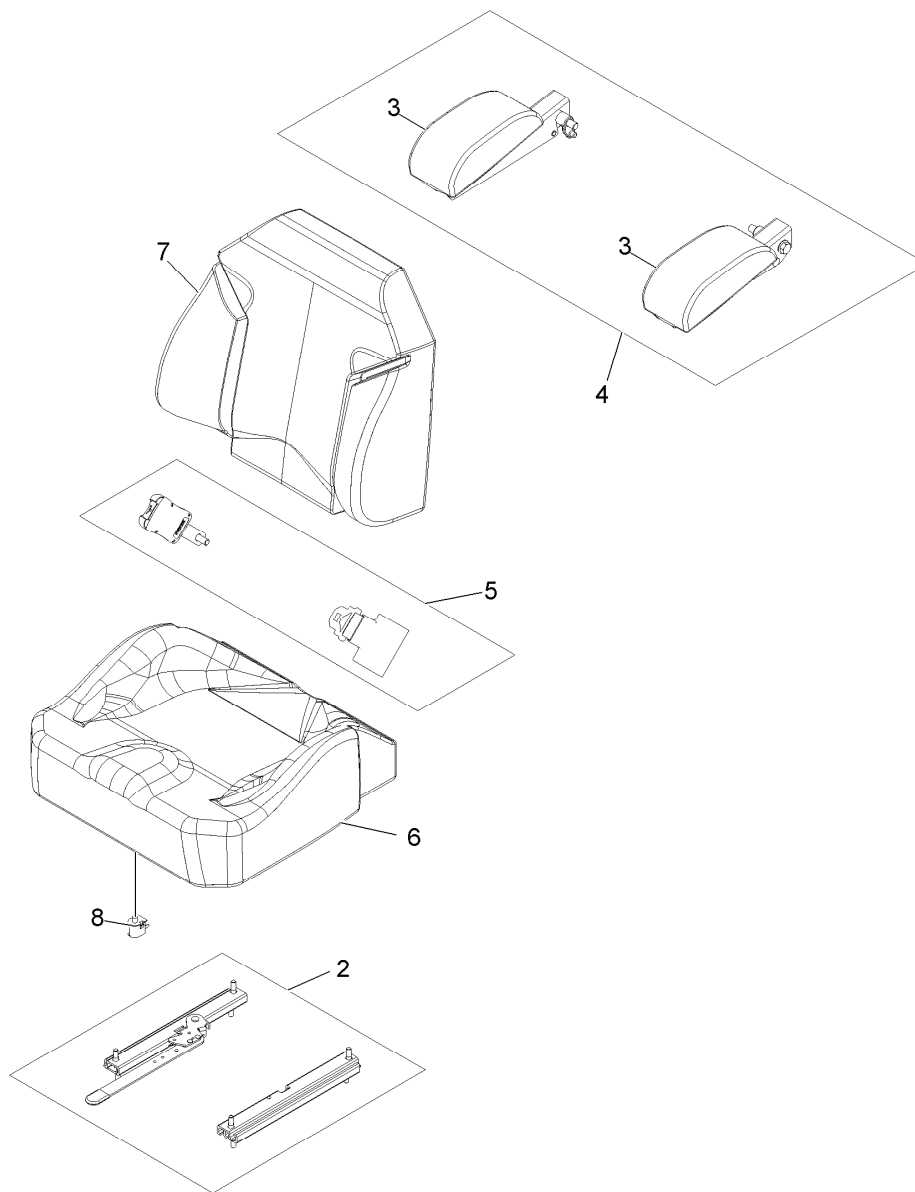

Seat W/Tracks Assembly No. 116-4474

| <i>Ref.</i> | <i>Part Number</i> | <i>Qty.</i> | <i>Description</i> |
|-------------|--------------------|-------------|--------------------|
| 2 | 109-9801 | 1 | Seat Track Set |
| 3 | 109-9802 | 1 | Arm Rest Pad Set |
| 4 | 109-9803 | 1 | Arm Rest Set |
| 5 | 109-9805 | 1 | Seat Belt Kit |
| 6 | 116-4925 | 1 | Cover,Cushion |
| 7 | 116-4926 | 1 | Cover,Back |
| 8 | 82-2190 | 1 | Switch |

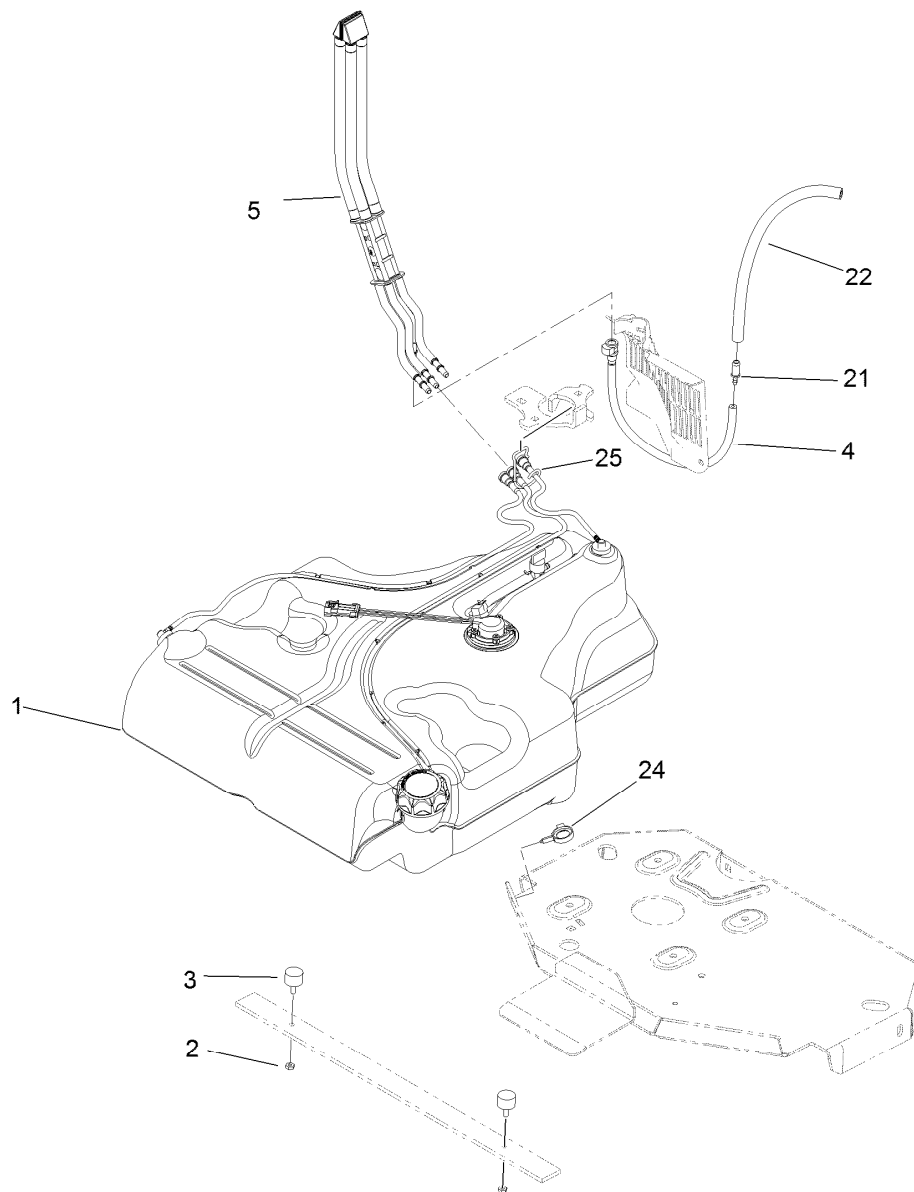

Fuel Tank Mounting Assembly

| Ref. | Part Number | Qty. | Description |
|------|-------------|------|-------------------------|
| 1 | 116-3979 | 1 | Fuel Tank ASM |
| 2 | 3218-1 | 2 | Nut-Jam |
| 3 | 116-6380 | 2 | Bumper-Rubber (W/ Stud) |
| 4 | 116-3977 | 1 | Hose ASM |
| 5 | 109-9491 | 1 | Fuel Manifold Vent ASM |
| 21 | 98-2952 | 1 | Fitting-Straight |
| 22 | 116-5087 | 1 | Hose-Fuel |
| 24 | 105-1853 | 1 | Clamp-Hose |
| 25 | 116-6005 | 1 | Retainer-Vapor Line |

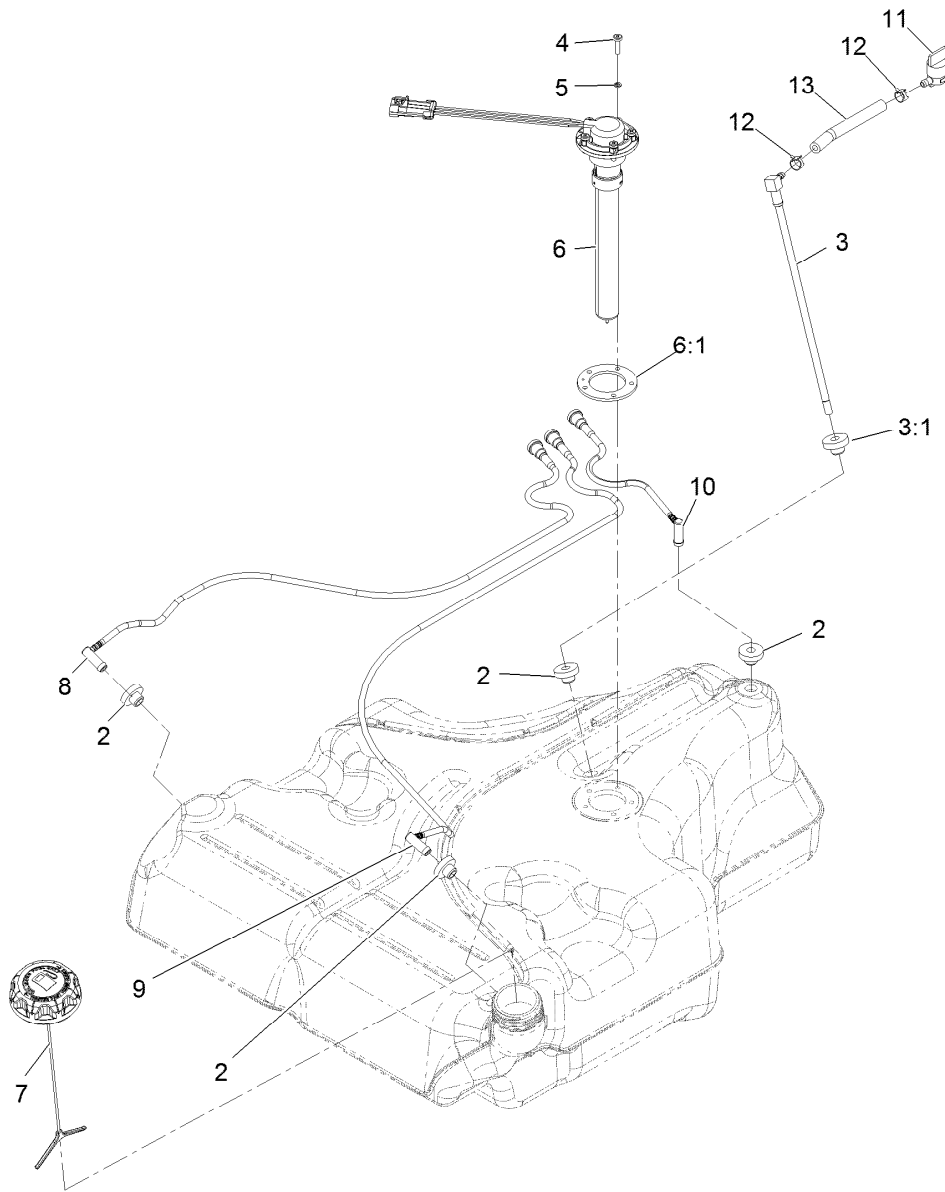

Fuel Tank Assembly No. 116-3979

| Ref. | Part Number | Qty. | Description |
|------|-------------|------|-----------------------------------|
| 2 | 46-6560 | 4 | Bushing |
| 3 | 116-2459 | 1 | Fuel Line Kit (With Grommet) |
| 3:1 | 46-6560 | 1 | Bushing |
| 4 | 9107944 | 5 | Screw-Pan 10-24 X 3/4 |
| 5 | 3253-17 | 5 | Washer-Lock 3/16 |
| 6 | 116-0003 | 1 | Sender-Fuel Level |
| 6:1 | 109-9620 | 1 | Gasket-Sender, Fuel |
| 7 | 126-1789 | 1 | Cap-Fuel, Ratcheting |
| 8 | 116-2460 | 1 | RH Vent Line Kit (With Grommet) |
| 9 | 116-2461 | 1 | LH Vent Line Kit (With Grommet) |
| 10 | 116-2462 | 1 | Rear Vent Line Kit (With Grommet) |
| 11 | 1-603770 | 1 | Valve-Fuel |
| 12 | 2412-98 | 2 | Clamp-Hose |
| 13 | 109-0650 | 1 | Hose-Fuel |

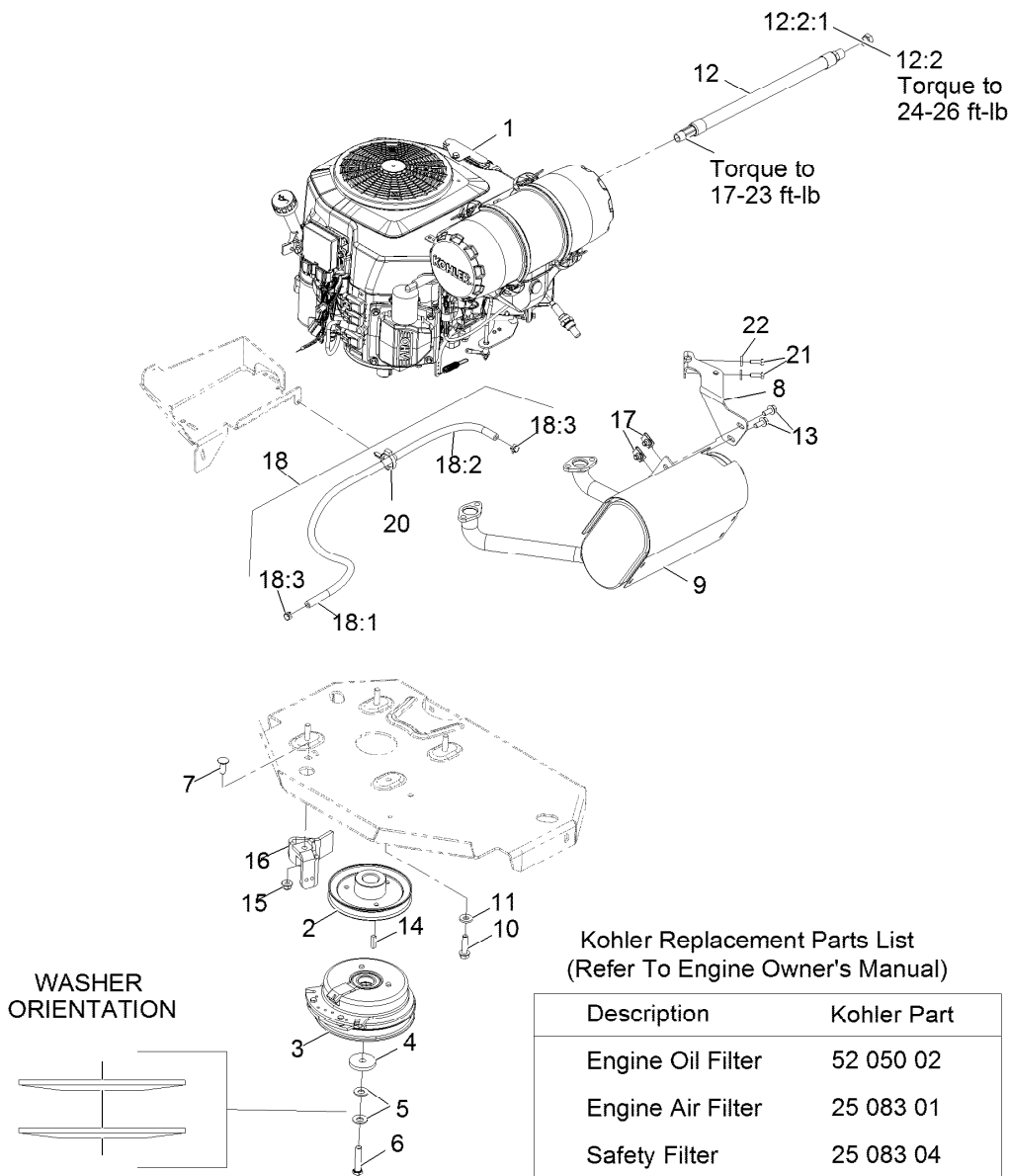

Engine Assembly

| Ref. | Part Number | Qty. | Description |
|------|-------------|------|----------------------------------|
| 1 | | 1 | Engine-Kohler, Ps-Ecv740-3012 ●■ |
| 2 | 109-9905 | 1 | Sheave |
| 3 | 116-1620 | 1 | Clutch Kit |
| 4 | 109-6919 | 1 | Washer-Clutch |
| 5 | 1-603610 | 2 | Washer-Spring Disc 7/16 |
| 6 | 109-9761 | 1 | Screw-HH ▲ |
| 7 | 3231-22 | 1 | Bolt-Carriage 3/8-16 X 1 |
| 8 | 116-4297 | 1 | Muffler Bracket Kit |
| 9 | 116-2038 | 1 | Muffler |
| 10 | 32144-102 | 4 | Screw-HWH 3/8-16 X 1 1/2 Taptite |
| 11 | 98-5975 | 4 | Washer-Spring Disc 3/8 |
| 12 | 116-5316 | 1 | Oil Drain Hose ASM |
| 12:2 | 353-508 | 1 | Plug-W/O-Ring |

| Ref. | Part Number | Qty. | Description |
|--------|-------------|------|------------------------------|
| 12:2:1 | 237-42 | 1 | O-Ring |
| 13 | 3234-5 | 2 | Screw-HH Flg 5/16-18 X 3/4 |
| 14 | 1-807259 | 1 | Key-Machine 1/4 X 1/4 X 1 |
| 15 | 104-8301 | 1 | Nut-Nyloc 3/8-16 Flg |
| 16 | 116-2612-01 | 1 | Clutch-Anchor |
| 17 | 94-2413 | 2 | U-Nut |
| 18 | 117-3893 | 1 | Fuel Line ASM |
| 18:1 | 109-0273 | 1 | Hose-Fuel Line 38 1/4" |
| 18:2 | 117-3892 | 1 | Sleeve-Thermal |
| 18:3 | 2412-98 | 2 | Clamp-Hose |
| 20 | 104-2490 | 1 | Clamp-Hose |
| 21 | 116-4295 | 2 | Screw-HH M6-1 X 20Mm W/Patch |
| 22 | 1-303435 | 2 | Washer-Spring Disc 1/4 |

● Not serviced separately

▲ Use Pro-Lock, Nut Type (P/N 1-840022, .5ml tube) on threads.

■ Obtain parts from www.kohlerplus.com

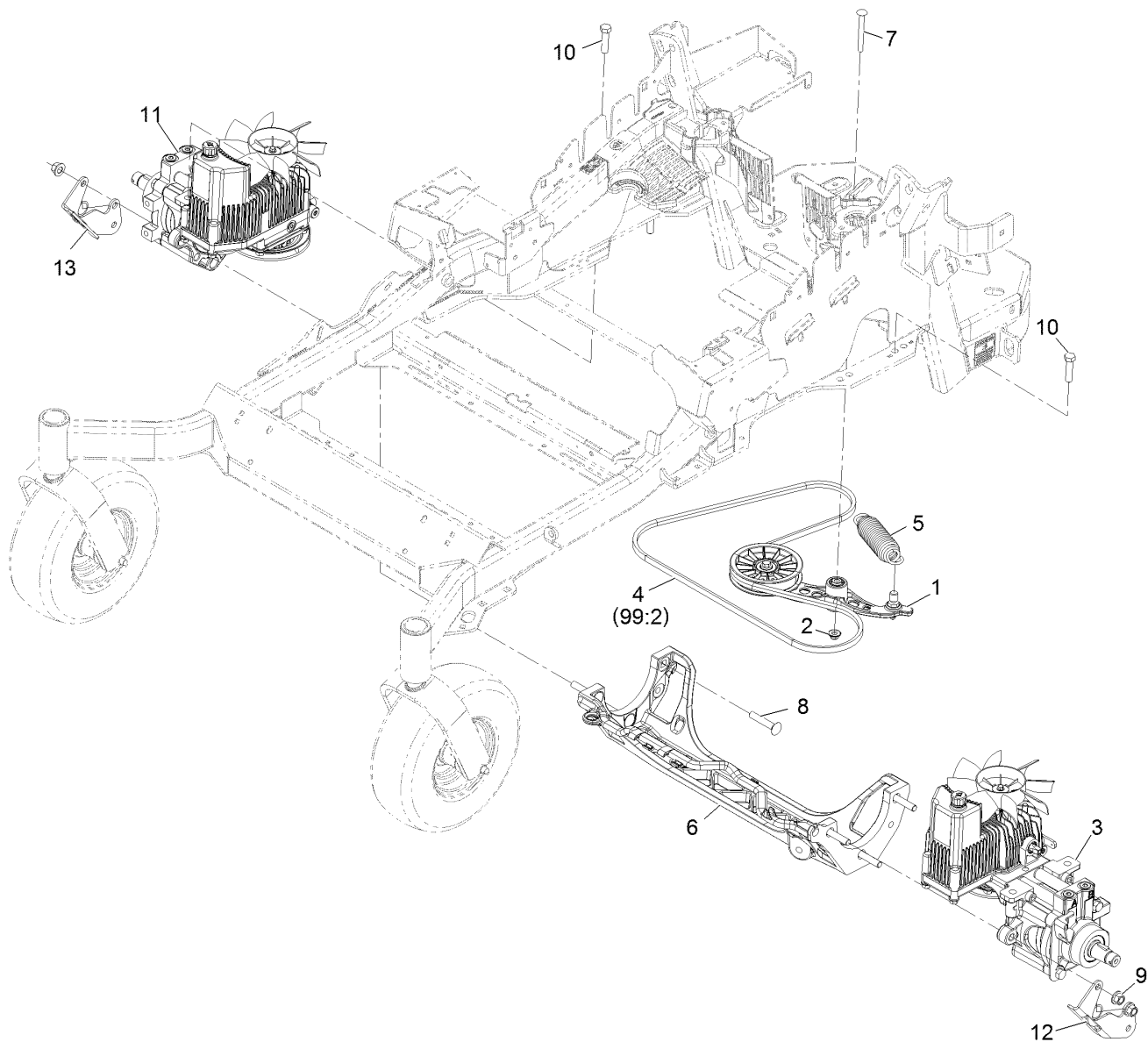

Hydraulic Assembly

| Ref. | Part Number | Qty. | Description |
|------|-------------|------|---------------------------------------|
| 1 | 116-1255 | 1 | Pump Idler ASM |
| 2 | 109-6658 | 1 | Nut-Nyloc 3/8-16 Flg |
| 3 | 116-6413 | 1 | LH Hydro ASM (12Cc W/Shock) |
| 4 | 109-3388 | 1 | Belt |
| 5 | 116-6317 | 1 | Spring-Extension |
| 6 | 109-9375 | 1 | Cradle-Hydro |
| 7 | 116-1502 | 1 | Bolt-Carriage Shoulder 3/8-16 X 3 1/2 |
| 8 | 126-0095 | 6 | Screw-CARR |
| 9 | 99-5107 | 6 | Nut-Lock 1/2-13 |
| 10 | 325-8 | 4 | Screw-HH 1/2-13 X 1 1/4 |
| 11 | 116-6414 | 1 | RH Hydro ASM (12Cc W/Shock) |

| Ref. | Part Number | Qty. | Description |
|------|-------------|------|---------------------------------|
| 12 | 125-9369-03 | 1 | Bracket-Discharge Mount, LH |
| 13 | 125-9370-03 | 1 | Bracket-Discharge Mount, RH |
| 99 | 109-9828 | 1 | Bottle-Oil, 32Oz Hydraulic ● |
| 99 | 116-0164 | 1 | Filter-Hydro ● |
| 99 | 116-1218 | 1 | Bottle,Oil 1 Gallon Hydraulic ● |
| 99 | 116-3270 | 1 | Kit, Hydro Service ● |
| 99:1 | 109-9828 | 4 | Bottle-Oil, 32Oz Hydraulic ● |
| 99:2 | 109-3388 | 1 | Belt |
| 99:3 | 116-0164 | 2 | Filter-Hydro ● |

● Not illustrated

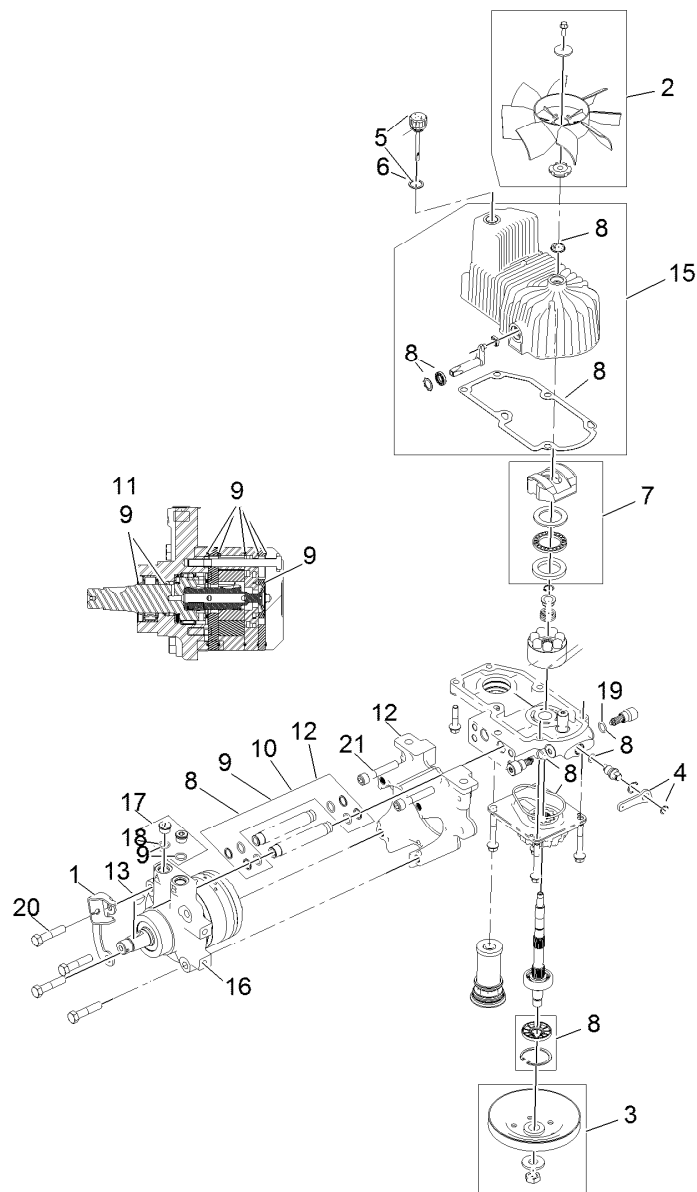

LH Hydro Assembly No. 116-6413

| Ref. | Part Number | Qty. | Description | Ref. | Part Number | Qty. | Description |
|------|-------------|------|----------------------------|------|-------------|------|----------------------------|
| 1 | 116-6859 | 1 | Bracket-Anchor, Cable | 11 | 116-1371 | 1 | Output Shaft Seal Kit |
| 2 | 116-0233 | 1 | Fan Kit | 12 | 116-5469 | 1 | Nose Cup-Uht |
| 3 | 116-0234 | 1 | Pulley Kit | 13 | 3257-42 | 1 | Key-Woodruff 5/16 X 1 |
| 4 | 116-0235 | 1 | Handle-Bypass Valve, Hydro | 15 | 116-3287 | 1 | Housing-LH |
| 5 | 116-0236 | 1 | Dipstick-Hydro W/Gasket | 16 | 116-8915 | 1 | Motor-Hydraulic LH 240Cc |
| 6 | 116-0237 | 1 | Gasket-Dipstick, Hydro | 17 | 116-7901 | 1 | Magnetic Plugs Service Kit |
| 7 | 116-1367 | 1 | Swash Block Kit | 18 | 76-1900 | 2 | O-Ring |
| 8 | 116-1368 | 1 | Pump Seal Kit | 19 | 116-8662 | 2 | O-Ring-Check Valve |
| 9 | 116-1369 | 1 | Motor Seal Kit | 20 | 116-8974 | 4 | Screw-HH 1/2-20 X 2 1/4 |
| 10 | 116-1370 | 1 | Tube Seal Kit | 21 | 116-8975 | 2 | Screw-HSH 1/2-20 X 2 3/4 |
| | | | | 99 | 116-1373 | 1 | Flow Test Kit ● |

● Not illustrated

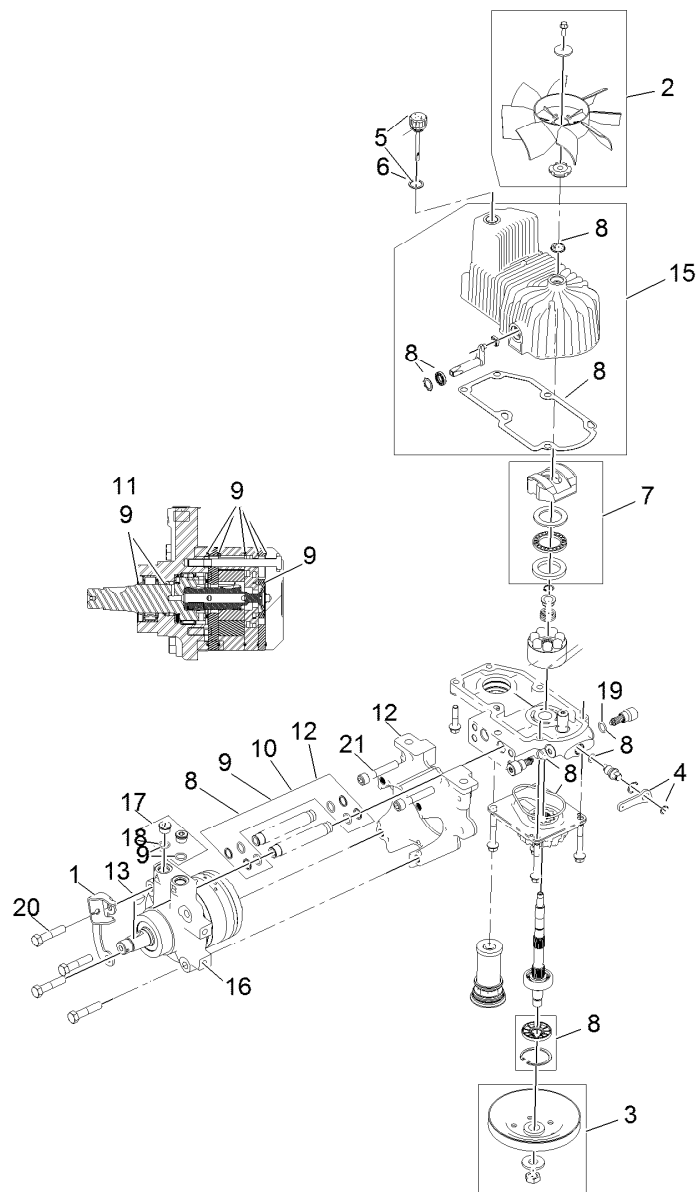

RH Hydro Assembly No. 116-6414

| Ref. | Part Number | Qty. | Description | Ref. | Part Number | Qty. | Description |
|------|-------------|------|-------------------------------|------|-------------|------|----------------------------|
| 1 | 116-6859 | 1 | Bracket-Anchor, Cable | 11 | 116-1371 | 1 | Output Shaft Seal Kit |
| 2 | 116-0233 | 1 | Fan Kit | 12 | 116-5469 | 1 | Nose Cup-Uht |
| 3 | 116-0234 | 1 | Pulley Kit | 13 | 3257-42 | 1 | Key-Woodruff 5/16 X 1 |
| 4 | 116-0235 | 1 | Handle-Bypass Valve, Hydro | 15 | 116-3288 | 1 | Housing-RH |
| 5 | 116-0236 | 1 | Dipstick-Hydro W/Gasket | 16 | 116-8916 | 1 | Motor-Hydraulic RH 240Cc |
| 6 | 116-0237 | 1 | Gasket-Dipstick, Hydro | 17 | 116-7901 | 1 | Magnetic Plugs Service Kit |
| 7 | 116-1367 | 1 | Swash Block Kit | 18 | 76-1900 | 2 | O-Ring |
| 8 | 116-1368 | 1 | Pump Seal Kit | 19 | 116-8662 | 2 | O-Ring-Check Valve |
| 9 | 116-1369 | 1 | Motor Seal Kit | 20 | 116-8974 | 4 | Screw-HH 1/2-20 X 2 1/4 |
| 10 | 116-1370 | 1 | Tube Seal Kit | 21 | 116-8975 | 2 | Screw-HSH 1/2-20 X 2 3/4 |
| | | | | 99 | 116-1373 | 1 | Flow Test Kit ● |

● Not illustrated

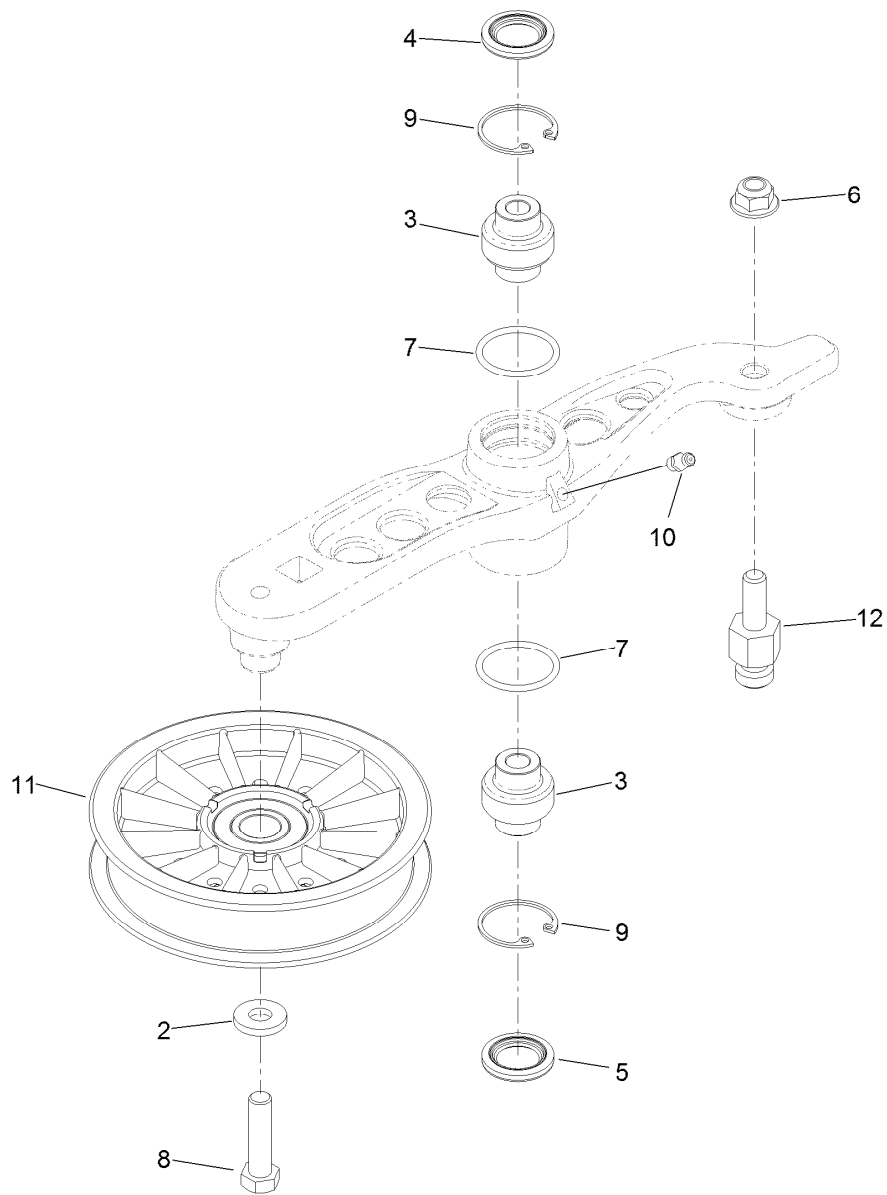

Pump Idler Assembly No. 116-1255

| Ref. | Part Number | Qty. | Description |
|------|-------------|------|--------------------|
| 2 | 43-0940 | 1 | Spacer |
| 3 | 103-3504 | 2 | Bearing-Spherical |
| 4 | 103-3505 | 1 | Seal-Double Lip |
| 5 | 103-3506 | 1 | Seal-Single Lip |
| 6 | 109-6658 | 1 | Nut-Flange, NI |
| 7 | 106-7159 | 2 | O-Ring |
| 8 | 323-8 | 1 | Screw-HH |
| 9 | 32120-10 | 2 | Ring-Snap |
| 10 | 302-19 | 1 | Fitting-Grease |
| 11 | 109-8076 | 1 | Pulley-Idler |
| 12 | 116-3467 | 1 | Pin-Spring, Anchor |

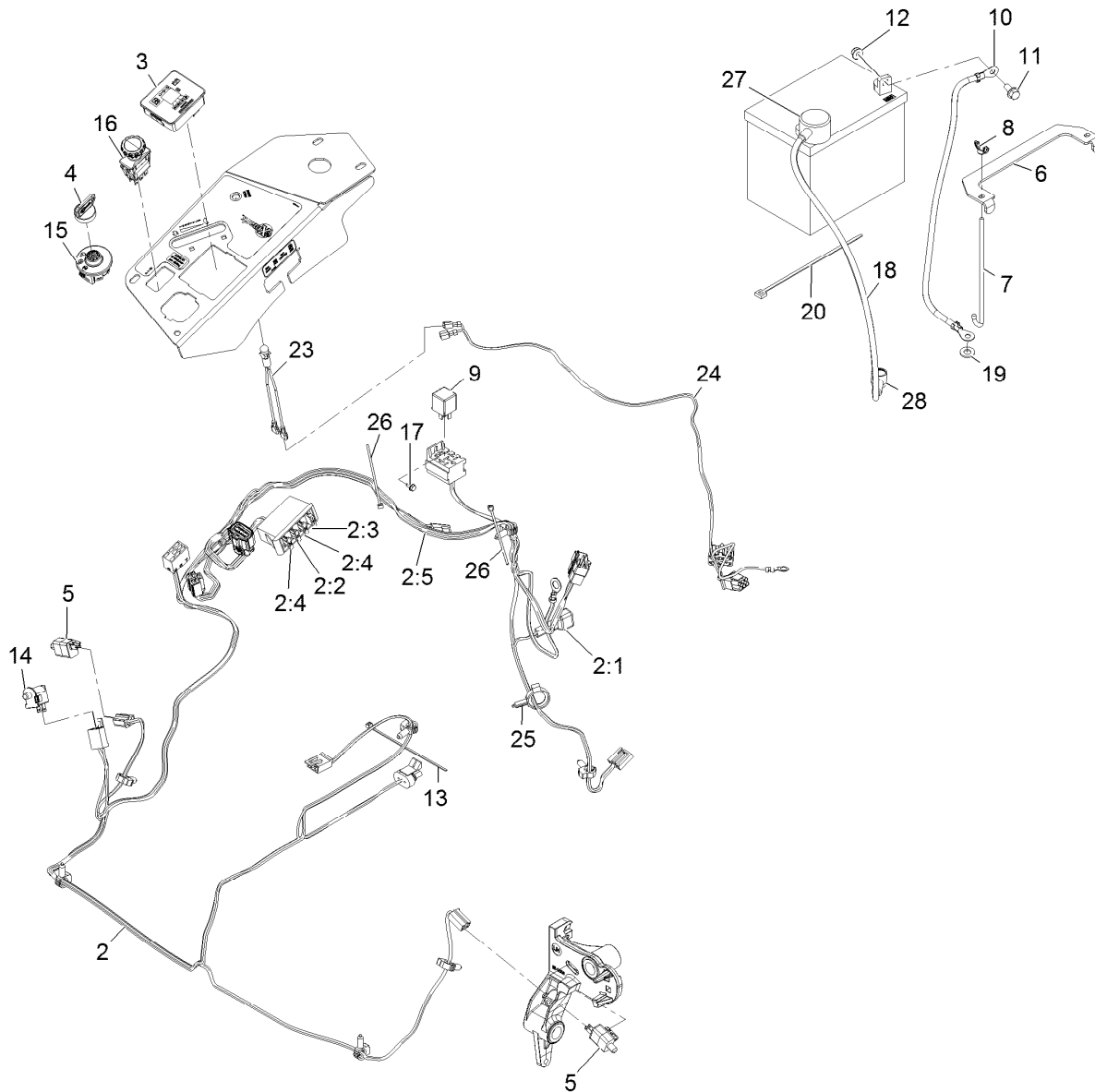

Electrical Assembly

| Ref. | Part Number | Qty. | Description | Ref. | Part Number | Qty. | Description |
|------|-------------|------|----------------------------|------|-------------|------|---------------------------|
| 2 | 116-6009 | 1 | Harness-Wire, Main ● | 12 | 104-8300 | 2 | Nut-Nyloc 5/16-18 Flg |
| 2:1 | 103-3895 | 1 | Diode-Tvs | 13 | 1-303287 | 3 | Tie-Cable 5 1/2 (Small) |
| 2:2 | 218-578 | 1 | Fuse-Blade, 10 Amp | 14 | 82-2190 | 1 | Switch |
| 2:3 | 109355 | 1 | Fuse-Blade, 15 Amp | 15 | 117-2221 | 1 | Switch-Ignition |
| 2:4 | 109102 | 2 | Fuse-Blade, 25 Amp | 16 | 116-0124 | 1 | Switch-PTO, 10A |
| 2:5 | 116-0053 | 1 | Cap-Plug | 17 | 104-2065 | 1 | Screw-HWH #10-24 X 3/8 |
| 3 | 117-3882 | 1 | Fuel/Hour Meter ASM | 18 | 115-3864 | 1 | Cable-Battery, Positive |
| 4 | 1-603511 | 1 | Key-Ignition | 19 | 3256-24 | 1 | Washer-3/8 Sae |
| 4 | 103-2106 | 1 | Key-Exmark Logo | 20 | 1-303335 | 1 | Tie-Cable 7 15/16 (Large) |
| 5 | 110-6765 | 2 | Switch-Single Pole No | 23 | 1-643267 | 1 | Indicator-Red Led |
| 6 | 116-0042-03 | 1 | Strap-Tie Down, Battery | 24 | 116-3062 | 1 | Harness-Indicator Light |
| 7 | 1-633651 | 2 | Bolt-Holddown | 25 | 105-1853 | 1 | Clamp-Hose |
| 8 | 1-543792 | 2 | Wingnut-Nyloc 1/4-20 | 26 | 1-303287 | 2 | Tie-Cable 5 1/2 (Small) |
| 9 | 1-643275 | 1 | Relay-12Vdc 40 Amp | 27 | 109-2407 | 1 | Insulator-Battery |
| 10 | 114-1218 | 1 | Cable-Battery, Negative | 28 | 1-543393 | 1 | Insulator-Solenoid |
| 11 | 3234-5 | 2 | Screw-HH Flg 5/16-18 X 3/4 | | | | |

● Use dielectric grease on all unsealed connectors and terminals only. Do not apply in sealed connectors.

Notes:

Notes:

MAXIMIZE THE PERFORMANCE OF YOUR EXMARK.

4-CYCLE PREMIUM ENGINE OIL

Part No. 116-3373

Both SAE 30 and SAE 10W-30 in one bottle.

Contains increased levels of zinc and phosphorus for better lubricity.

No Viscosity Index Improvers that tend to shear down in high heat.

Synthetic formulation.

Gas & Diesel compatible.

Anti-corrosion additives.

API 'SL' and JASO rated with wet clutch compatibility for other machines.

PREMIUM HYDRO OIL

Part No. 109-9828

Commercial quality for tough, high-heat conditions.

Designed specifically for zero-turn mower hydraulic systems.

Superior shear resistance under heavy loads.

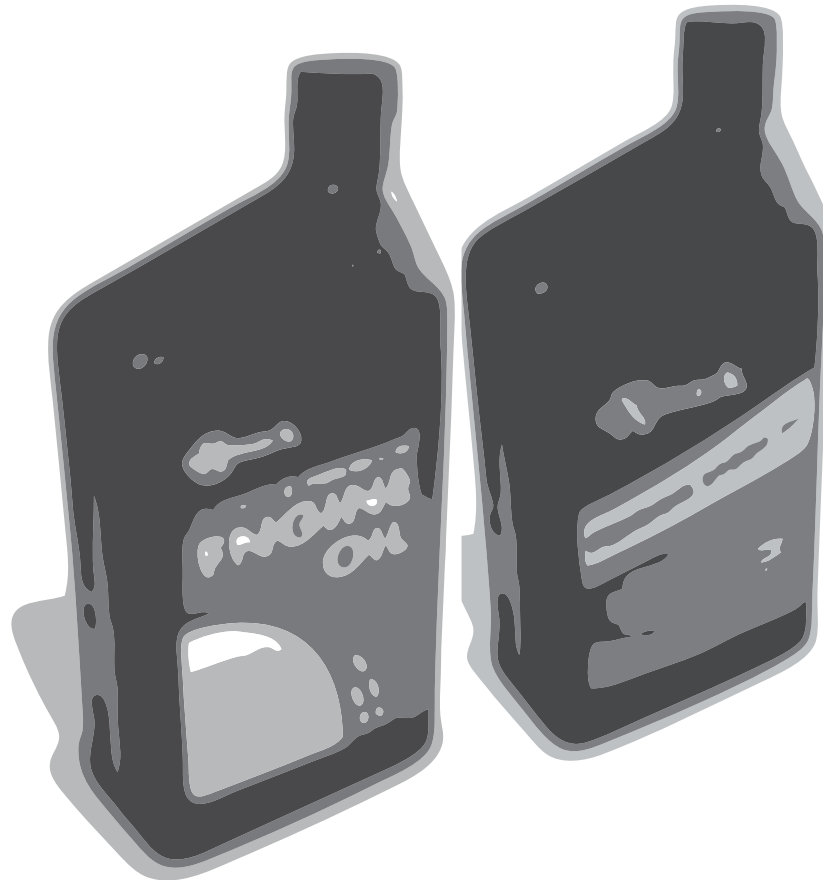

Available from your local Exmark dealer. Find your closest dealer at exmark.com

EXMARK ACCESSORIES AND OPTIONS*

MID-MOUNT RIDING ACCESSORIES AND OPTIONS

| | |
|------------------------------------|---------------------------------|
| CUSTOM RIDE SEAT SUSPENSION SYSTEM | OPERATOR CONTROLLED DISCHARGE |
| FULL SUSPENSION SEAT | SUN SHADE |
| DECK LIFT ASSIST KIT | TRASH CONTAINER |
| HITCH KIT | TURF STRIPER |
| LIGHT KIT | ULTRA VAC COLLECTION SYSTEM |
| 12V POWER PORT | ULTRA VAC QUICK DISPOSAL SYSTEM |
| MICRO-MULCH SYSTEM | |

OUT-FRONT RIDING ACCESSORIES AND OPTIONS

| | |
|------------------------------------|---------------------------------|
| CUSTOM RIDE SEAT SUSPENSION SYSTEM | SNOW BLADE |
| DUAL-TAIL WHEEL | SNOWBLOWER |
| FLOOR PAN EXTENDER | SUN SHADE |
| HITCH KIT | TRASH CONTAINER |
| LIGHT KIT | ULTRA VAC COLLECTION SYSTEM |
| MICRO-MULCH SYSTEM | ULTRA VAC QUICK DISPOSAL SYSTEM |
| ROLL OVER PROTECTION SYSTEM (ROPS) | WEATHER CAB |

WALK-BEHIND ACCESSORIES AND OPTIONS

| | |
|--------------------|--------------|
| GRASS CATCHER | TURF STRIPER |
| MICRO-MULCH SYSTEM | STANDON |

*Some accessories and options not available for some models.

Place Model No. and Serial No.
Label Here (Included in the Literature
Pack) or Fill in Below

Model No. _____

Serial No. _____

Date Purchased _____

Engine Model No. and Spec. No. _____

Engine Serial No. (E/No) _____

© 2014 Exmark Mfg. Co., Inc.
Industrial Park Box 808
Beatrice, NE 68310
All Rights Reserved

Part No. 4501-747 Rev. A
(402) 223-6300
Fax (402) 223-5489
Printed in the USA.

