

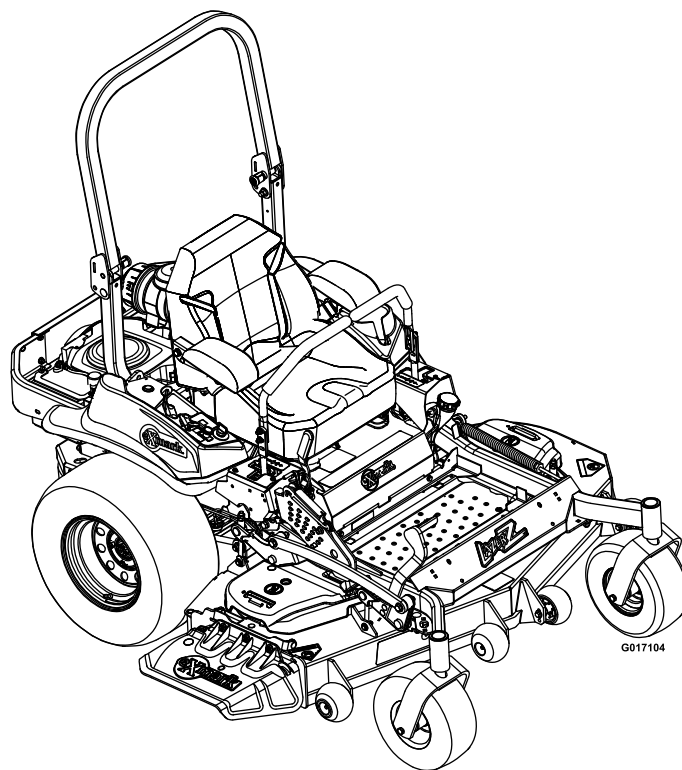

LAZER Z[®] X-SERIES

Model No. LZX980EKC726—Serial No. 31400000 and Up

Picture below may not reflect actual product.



Parts Manual

Part No. 4501-737 Rev. A

Ordering Replacement Parts

To order replacement parts, please supply the part number, the quantity, and the description of each part desired.

Understanding Reference Numbers

Each identified part in an illustration has a reference number. The reference number for a part also appears in the parts list, along with other information about the part.

This catalog uses two special reference number formats, one to indicate parts in a service assembly and another to indicate the quantity of a given part in an illustration.

Service Assembly Reference Numbers

Parts in service assemblies have reference numbers in the form a:b. The a represents the reference number of the entire service assembly and the b represents a sequential number unique to each part within the service assembly.

For example, a wheel assembly might be identified by reference number 6, the tire by 6:1, the valve by 6:2, and the wheel by 6:3. When you order the assembly identified by reference number 6, you receive all parts identified by reference numbers 6:1, 6:2, and 6:3. However, you may also order any part individually. Reference numbers of this type appear in illustration and in parts lists.

Reference Numbers Indicating Quantity

In an illustration, if a reference number indicates more than one part, the reference number has the form nX y. The n represents the quantity of the part, the X is the multiplication symbol, and the y represents the reference number.

For example, in an illustration, the reference number 2X 37 means that two of the parts identified by reference number 37 are indicated.

List of Abbreviations

AR: as required	HJ: hex jam	PRH: phillips round head
ASM: assembly	HLH: hex lag head	PTH: phillips truss head
BBC: blade brake control	HOC: height-of-cut	PTO: power-take-off
BHTF: button head thread forming	HSBH: hex socket button head	RH: right hand
CARR: carriage	HSFH: hex socket flat head	ROPS: roll-over protection system
CCW: counter clockwise	HSH: hex socket head	RRB: rear roller brush
CW: clockwise	HWH: hex washer head	SFH: slotted fillister head
DEG: degrees	HWHTF: hex washer head thread forming	SHH: slotted hex head
DPA: Dual Point Adjustment	HYD: hydraulic	SHWH: slotted hex washer head
ECM: electronic control module	LH: left hand	SPH: slotted pan head
EXT: external	LP: Liquefied Petroleum Gas	SQH: square head
FH: flat head	LPG: Liquefied Petroleum Gas	SRH: slotted round head
GA: gauge	NI: nylon insert	STD: standard
HD: heavy-duty	NPTF: national pipe thread fine	TAP: self tapping
HF: hex flange	PFH: phillips flat head	TTH: torx truss head
HH: hex head	PPH: phillips pan head	
HHF: hex head flange	PPHTF: phillips pan head thread forming	
HHFTF: hex head flange thread forming		

Touch Up Paint

Exmark black touch up spray paint – gloss black.

Exmark red touch up paint (spray paint – P/N 1-850337 - .6 oz liquid bottle – P/N 103-9140).



If your Exmark dealer does not have the Exmark part in stock, Exmark will get the parts to the dealer the next business day or the part will be FREE Guaranteed!! (Some restrictions apply. See your participating Exmark Dealer for details.)

Contents

Complete Deck Assembly.....	4
Deck Assembly.....	5
Deck W/Decals No. 109-9133.....	6
Deck Idler Assembly No. 116-3755.....	7
Cutter Housing Assembly No. 103-9539.....	8
Main Frame Assembly.....	9
Roll-over Protection System Assembly No. 116-0230.....	10
Caster Wheel and Fork Assembly.....	11
Deck Lift Assembly.....	12
Height-of-Cut Assembly No. 109-7438.....	13
Controls Assembly.....	14
Motion Control Assembly.....	15
Rear Wheel and Park Brake Assembly.....	16
Parking Brake Handle Assembly No. 116-7551.....	17
Seat Assembly.....	18
Seat W/Tracks Assembly No. 116-8912.....	19
Fuel Tank Assembly.....	20
Fuel Tank Assembly No. 116-3979.....	21
Engine Assembly.....	22
Hydraulic Assembly.....	23
LH Hydro Assembly No. 116-6409.....	24
RH Hydro Assembly No. 116-6410.....	25
Pump Idler Assembly No. 116-1255.....	26
Electrical Assembly.....	27

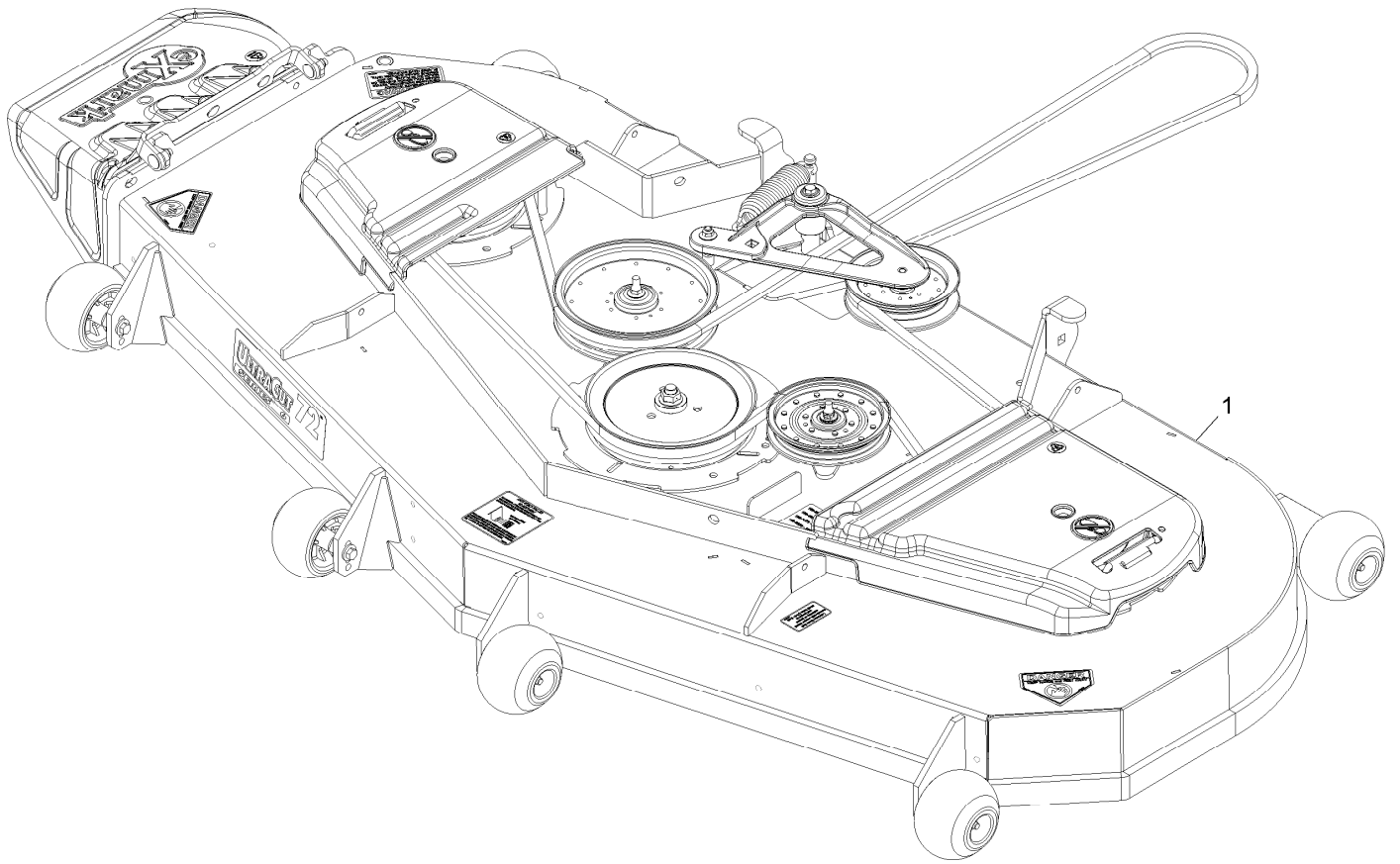

Complete Deck Assembly

<i>Ref.</i>	<i>Part Number</i>	<i>Qty.</i>	<i>Description</i>
1	109-9649	1	Complete Deck ASM-726

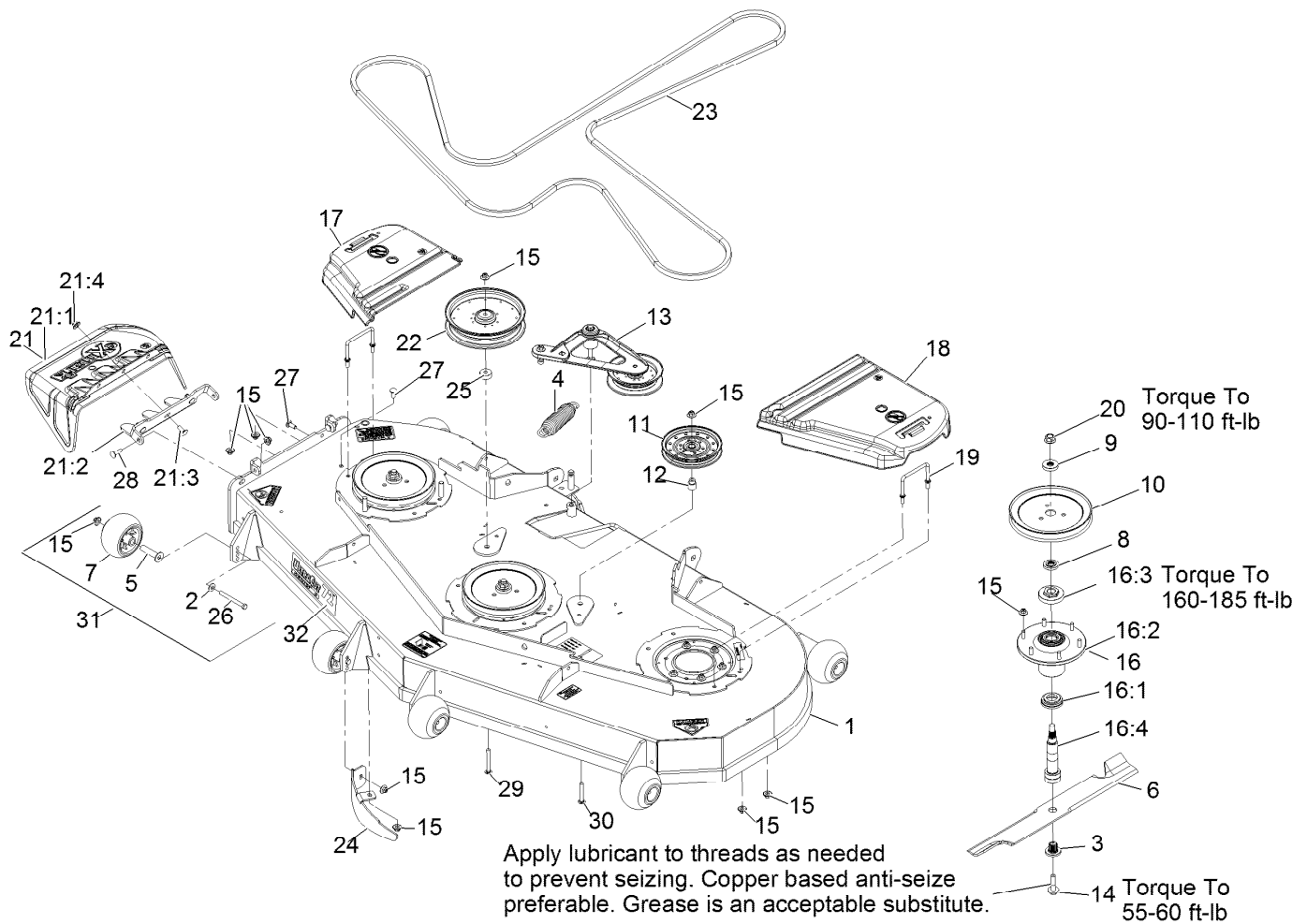

Deck Assembly

Ref.	Part Number	Qty.	Description	Ref.	Part Number	Qty.	Description
1	109-9133	1	Deck W/ Decals ASM-72	16:4	109-6881	1	Spindle,Double Spline ■
2	98-5975	6	Washer-Spring Disc 3/8	17	116-0094	1	Cover-Belt, RH
3	103-3037	3	Bushing, Splined	18	109-6938	1	Cover-Belt, LH
4	116-6317	1	Spring-Extension	19	109-6982	2	Wireform-Cover
5	116-8131	6	Axle, Roller	20	109-7033	3	Nut-Flange 5/8-18 Centerlock
6	103-6404	3	Blade, Notched (72")	21	109-7188	1	ASM,Discharge Chute
6	103-6394	3	Blade, Mulching (72") ●	21:1	109-2738	1	Chute, Discharge
6	103-6389	3	Blade, Low Lift (72")	21:2	109-8675-01	1	Bracket,Discharge Chute
6	103-6384	3	Blade, Solid (72")	21:3	3231-22	3	Bolt-Carriage 3/8-16 X 1
6	116-5171	3	Blade-Extreme 2, 24.50"	21:4	109-6658	3	Nut-Nyloc 3/8-16 Flg
7	103-8415	6	Roller, Anti-Scalp	22	109-8590	1	Pulley-Idler
8	103-9522	3	Spacer, Splined Stepped	23	109-9023	1	Belt,V-5V X 219.00"
9	103-9523	3	Spacer, Splined	24	116-5834-01	1	Baffle-Dogleg, Lz72
10	109-2180	3	Sheave,Blade Drive 9.00	25	103-2956	1	Spacer-Idler
11	116-4667	1	Idler-Pulley, Flat	26	116-9362	6	Screw-HH
12	1-633456	1	Bushing, Idler	27	3231-22	2	Bolt-Carriage 3/8-16 X 1
13	116-3755	1	Deck Idler ASM	28	3231-28	2	Bolt-Carriage 3/8-16 X 1 1/4
14	109-9220	3	Screw-Sems 1/2-20 X 2.19	29	3231-42	1	Bolt-Carriage 3/8-16 X 3
15	109-6658	34	Nut-Nyloc 3/8-16 Flg	30	3231-44	1	Bolt-Carriage 3/8-16 X 2 1/2
16	109-6917	3	ASM,Spindle Housing	31	116-9981	6	Kit, Anti-Scalp Roller
16:1	103-9504	1	Guard, Bottom	32	109-9440	1	Decal,Ultracut 72 Series 6
16:2	103-9539	1	Asm, Cutter Housing				
16:3	109-0916	1	Nut, Spindle 7/8-14				

● Requires installation of mulch kit for proper mulching. See your Exmark dealer for details.

■ Apply Mobil HTS grease (P/N 103-5217 1.5 oz packet) (or a food-grade anti-seize). See operator s manual for locations.

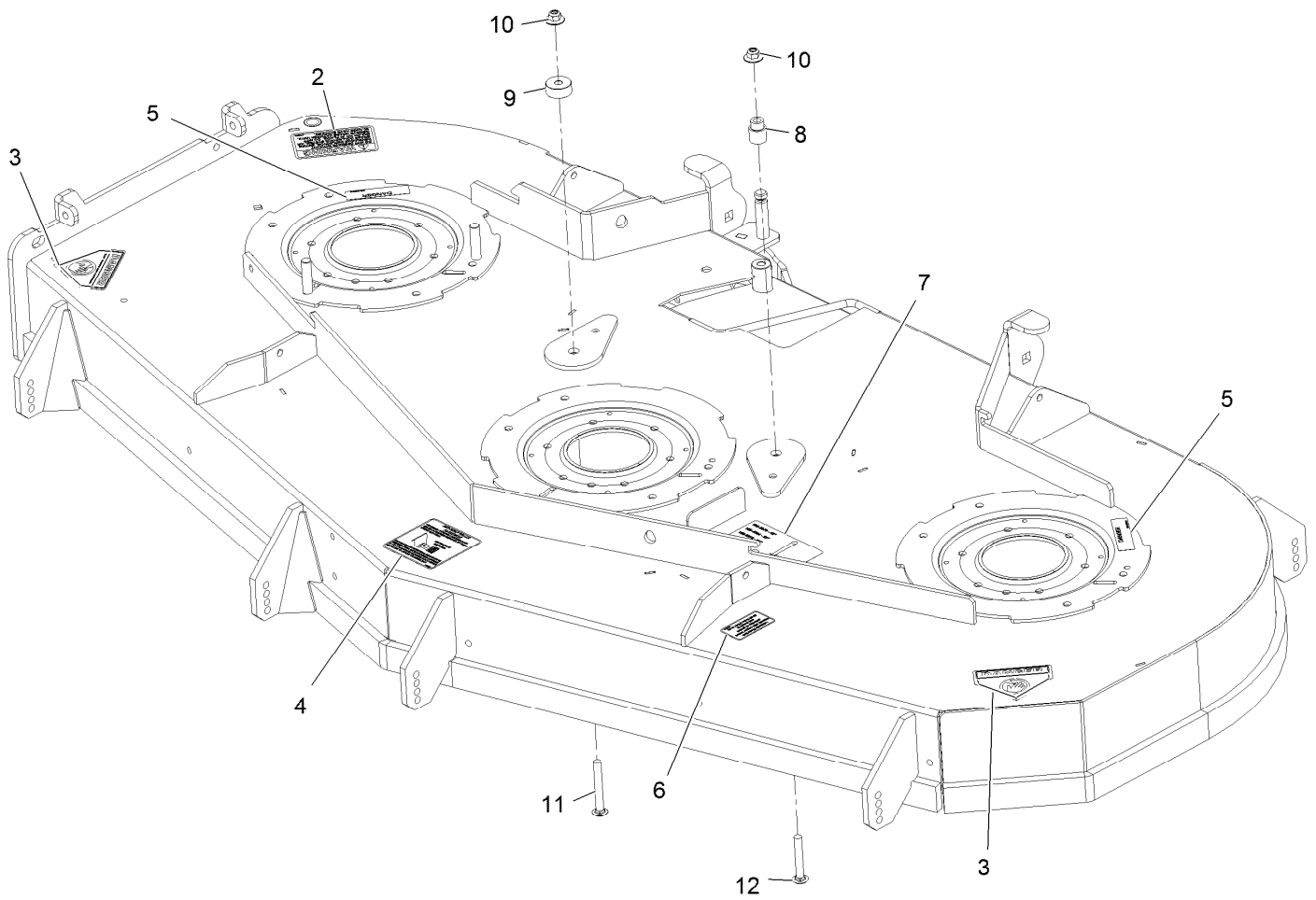

Deck W/Decals No. 109-9133

Ref.	Part Number	Qty.	Description
2	1-303508	1	Decal-Warning, Discharge
3	1-403005	2	Decal-Danger
4	1-633922	1	Decal, Anti-Scalp
5	98-5954	2	Decal-Cover, Missing
6	109-3148	1	Decal, Bolt Torque
7	109-9361	1	Decal,Belt Routing
8	1-633456	1	Bushing, Idler
9	103-2956	1	Spacer-Idler
10	109-6658	2	Nut-Nyloc 3/8-16 Flg
11	3231-42	1	Bolt-Carriage 3/8-16 X 3
12	3231-44	1	Bolt-Carriage 3/8-16 X 2 1/2

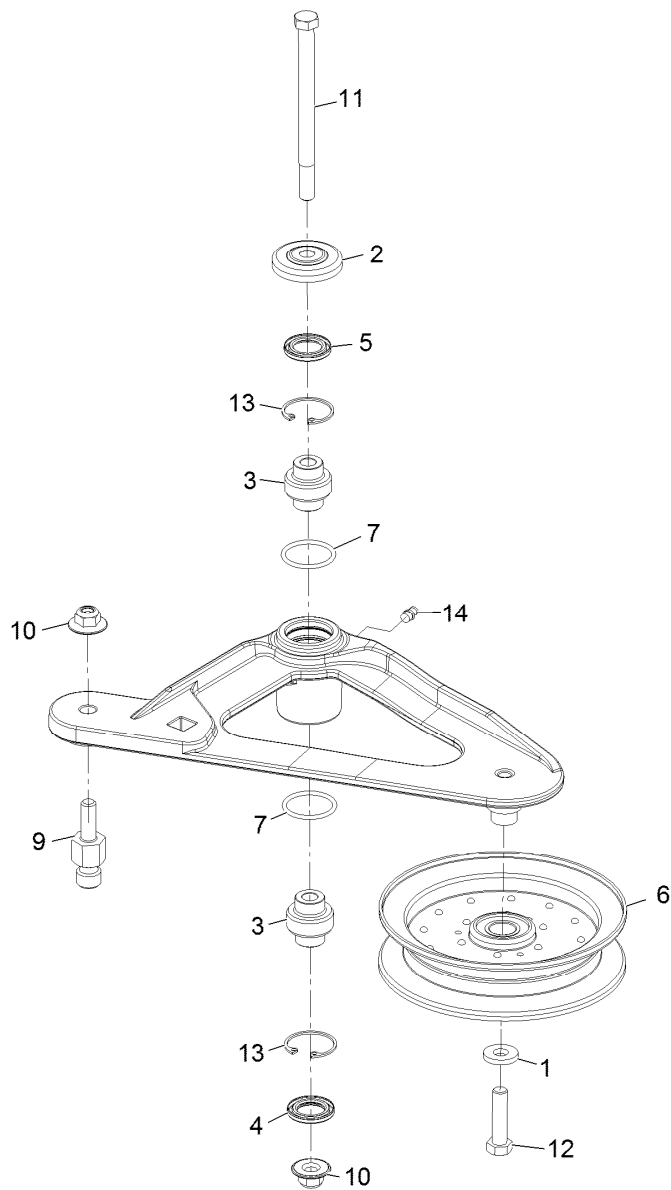

Deck Idler Assembly No. 116-3755

<i>Ref.</i>	<i>Part Number</i>	<i>Qty.</i>	<i>Description</i>
1	43-0940	1	Spacer
2	103-2916	1	Guard-Top
3	103-3504	2	Bearing-Spherical
4	103-3505	1	Seal-Double Lip
5	103-3506	1	Seal-Single Lip
6	116-4668	1	Idler-Pulley, Flanged
7	106-7159	2	O-Ring
9	126-0423	1	Pin-Spring, Anchor
10	109-6658	2	Nut-Nyloc 3/8-16 Flg
11	109-7409	1	Screw-Shoulder 3/8-16 X 5
12	323-8	1	Screw-HH 3/8-16 X 1 1/2
13	32120-10	2	Ring-Retaining
14	302-19	1	Zerk-1/4-28 Str

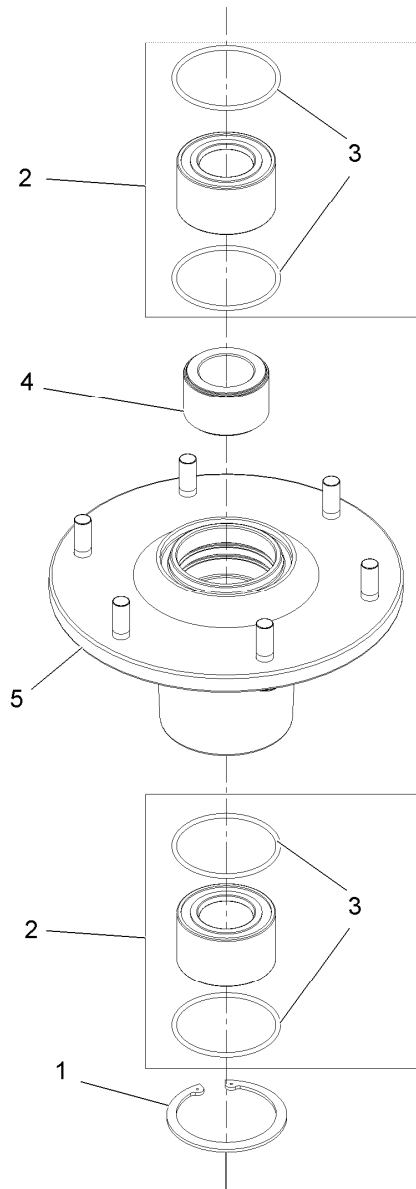

Cutter Housing Assembly No. 103-9539

<i>Ref.</i>	<i>Part Number</i>	<i>Qty.</i>	<i>Description</i>
1	92-5581	1	Ring-Retaining
2	109-2064	1	Asm, Bearing W/O-Rings
3	103-5895	4	O-Ring
4	103-9506	1	Spacer, Bearing
5	109-0764	1	Asm, Housing W/Studs

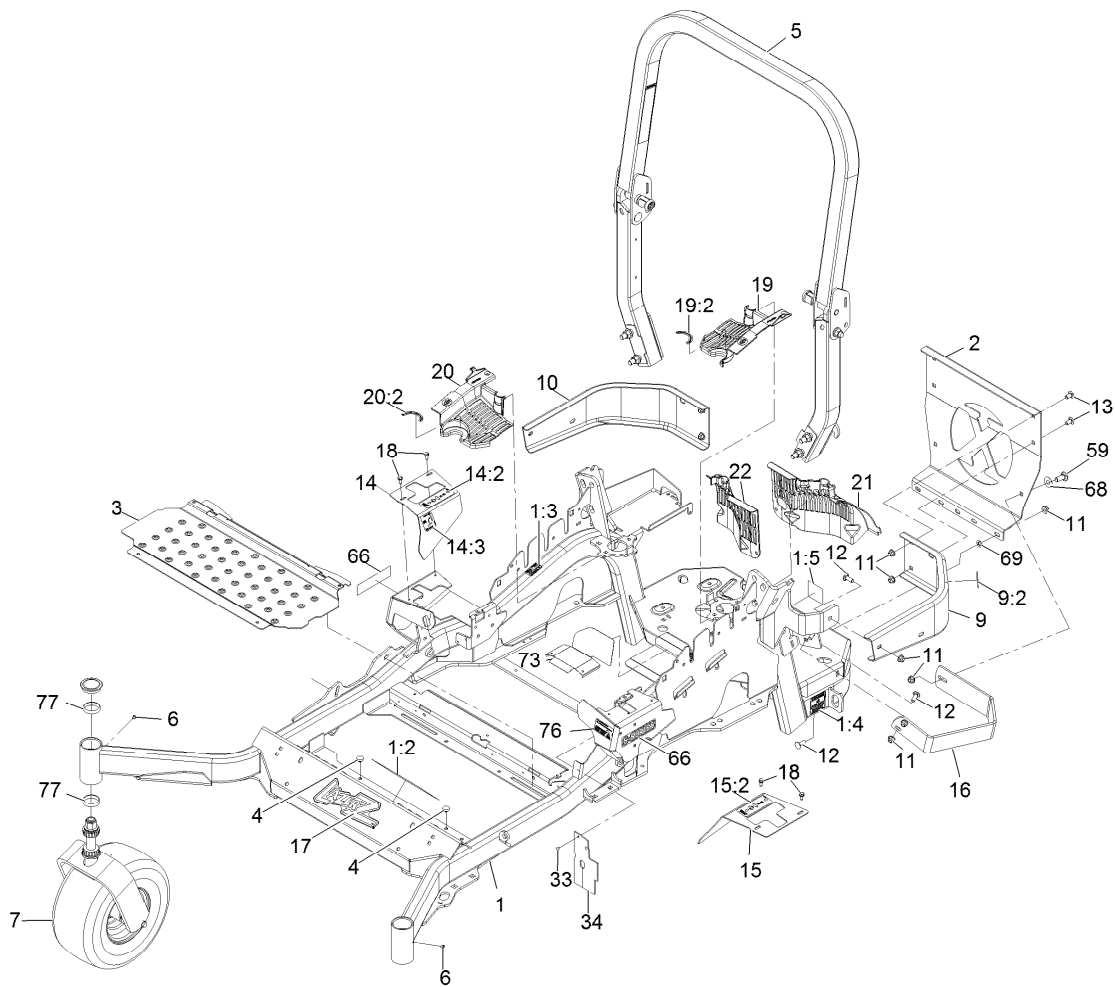

Main Frame Assembly

Ref.	Part Number	Qty.	Description	Ref.	Part Number	Qty.	Description
1	116-5904	1	Mainframe ASM	15	116-0580	1	LH Motion Control Cover ASM
1:2	103-2076	2	Decal-Caution	15:2	109-7232	1	Decal-Motion Control
1:3	116-3303	1	Decal-Slope	16	126-2067-03	1	Guard-Muffler
1:4	116-0205	2	Decal-Belt Drive	17	103-3113	1	Decal, Lazer Model
1:5	116-4858	1	Decal-Spark Arrester	18	32144-10	4	Screw-HWH 1/4-20 X .62
2	109-8863-03	1	Plate,Rear Guard	19	116-0170	1	LH Hydro Guard ASM
3	116-8898-01	1	Floorpan	19:2	116-0157	1	Decal-Hydro Oil
4	1-513658	2	Bumper	20	116-0171	1	RH Hydro Guard ASM
5	116-0230	1	ASM,ROPS Service Exmark	20:2	116-0157	1	Decal-Hydro Oil
6	1-811010	2	Plug	21	109-9709	1	Guard-Hydro Rear, LH Trim
7		2	Caster Wheel ASM ●	22	109-9058	1	Guard-Hydro, Rear RH
9	116-0180	1	LH Bumper ASM	33	1-803035	2	Rivet 3/16 X 1/4
9:2	103-2076	1	Decal-Caution	34	116-2362	1	Deflector-Air Flow
10	116-0057-03	1	Bumper-RH	59	323-6	1	Screw-HH 3/8-16 X 1
11	104-8301	11	Nut-Nyloc 3/8-16 Flg	66	116-3883	2	Decal-X-Series
12	3231-22	6	Bolt-Carriage 3/8-16 X 1	68	3256-24	1	Washer-3/8 Sae
13	3231-21	3	Bolt-Carriage 3/8-16 X 3/4	69	107-3154	2	Nut-Push 3/8-16
14	116-5899	1	RH Motion Control Cover ASM	73	126-0032-01	1	Guard-Exhaust
14:2	109-7232	1	Decal-Motion Control	76	116-1654	1	Decal-Fuel Fill
14:3	116-5944	1	Decal-Park Brake	77	1-543508	4	Cup-Bearing Tapered Roller

● Not serviced separately

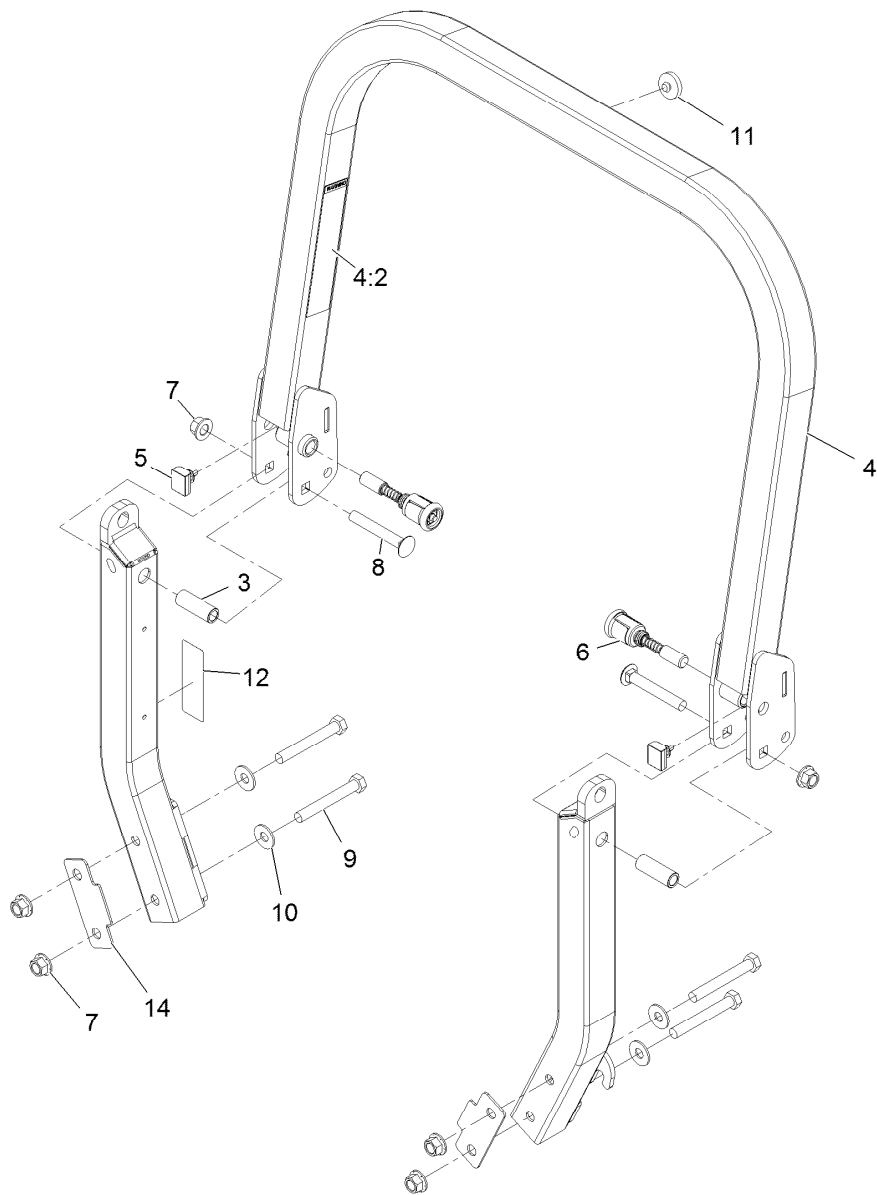

Roll-over Protection System Assembly No. 116-0230

<i>Ref.</i>	<i>Part Number</i>	<i>Qty.</i>	<i>Description</i>
3	109-6653	2	Spacer
4	116-0019	1	Upper ROPS ASM
4:2	107-2102	1	Decal-Warning, Folding ROPS
5	109-5337	2	Bumper-ROPS
6	116-0104	2	Pin-Spring
7	99-5107	6	Nut-Lock 1/2-13
8	3233-10	2	Bolt-Carriage 1/2-13 X 3 1/2
9	325-35	4	Screw-HH
10	109-9505	4	Washer, Spring Disc 1/2
11	109-9233	1	Bumper-Push-In, Rubber
12	116-0090	1	Decal-Caution
14	116-0960	2	Spacer

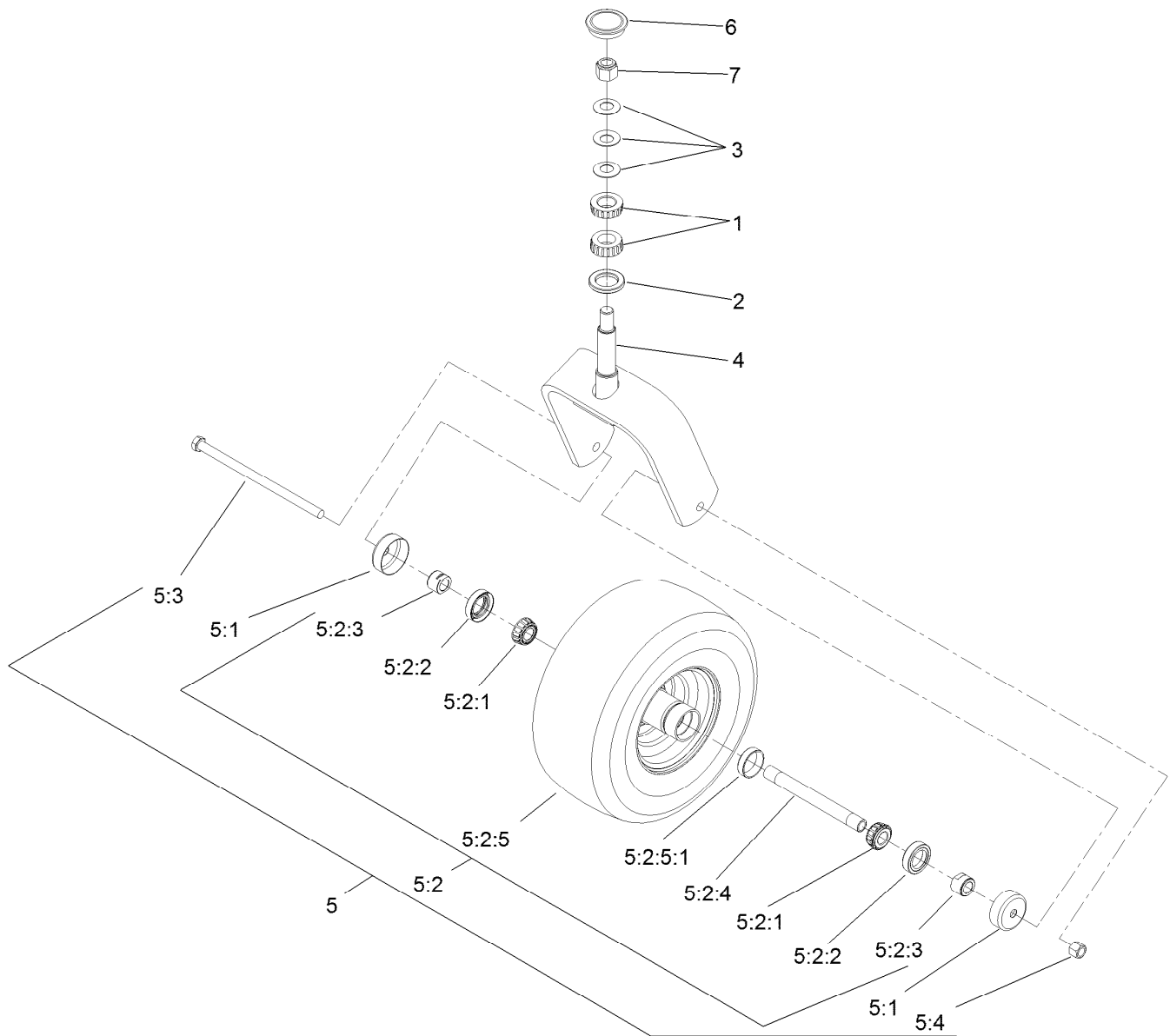

Caster Wheel and Fork Assembly

Ref.	Part Number	Qty.	Description	Ref.	Part Number	Qty.	Description
1	1-543509	2	Bearing-Roller, Tapered	5:2:3	103-3051	2	Spacer-Nut ■
2	116-5647	1	Seal-Grease	5:2:4	103-5156	1	Axle-Caster
3	1-633508	3	Washer-Bellville	5:2:5		1	Wheel And Tire ASM ●
4	116-6707-01	1	Caster	5:2:5:1	1-633584	1	Bearing-Cup
5	109-9127	1	Wheel And Tire ASM	5:3	325-39	1	Screw-HH
5:1	103-2768	2	Guard-Seal	5:4	3296-23	1	Nut-Lock, NI
5:2		1	Wheel And Tire ASM ●	6	103-4882	1	Cap-Grease
5:2:1	1-633585	2	Bearing-Cone, Taper	7	3296-51	1	Nut-Lock, NI
5:2:2	103-0063	2	Seal-Caster				

● Not serviced separately

■ Use Pro-Lock, Nut Type (P/N 1-840022, .5ml tube) on threads.

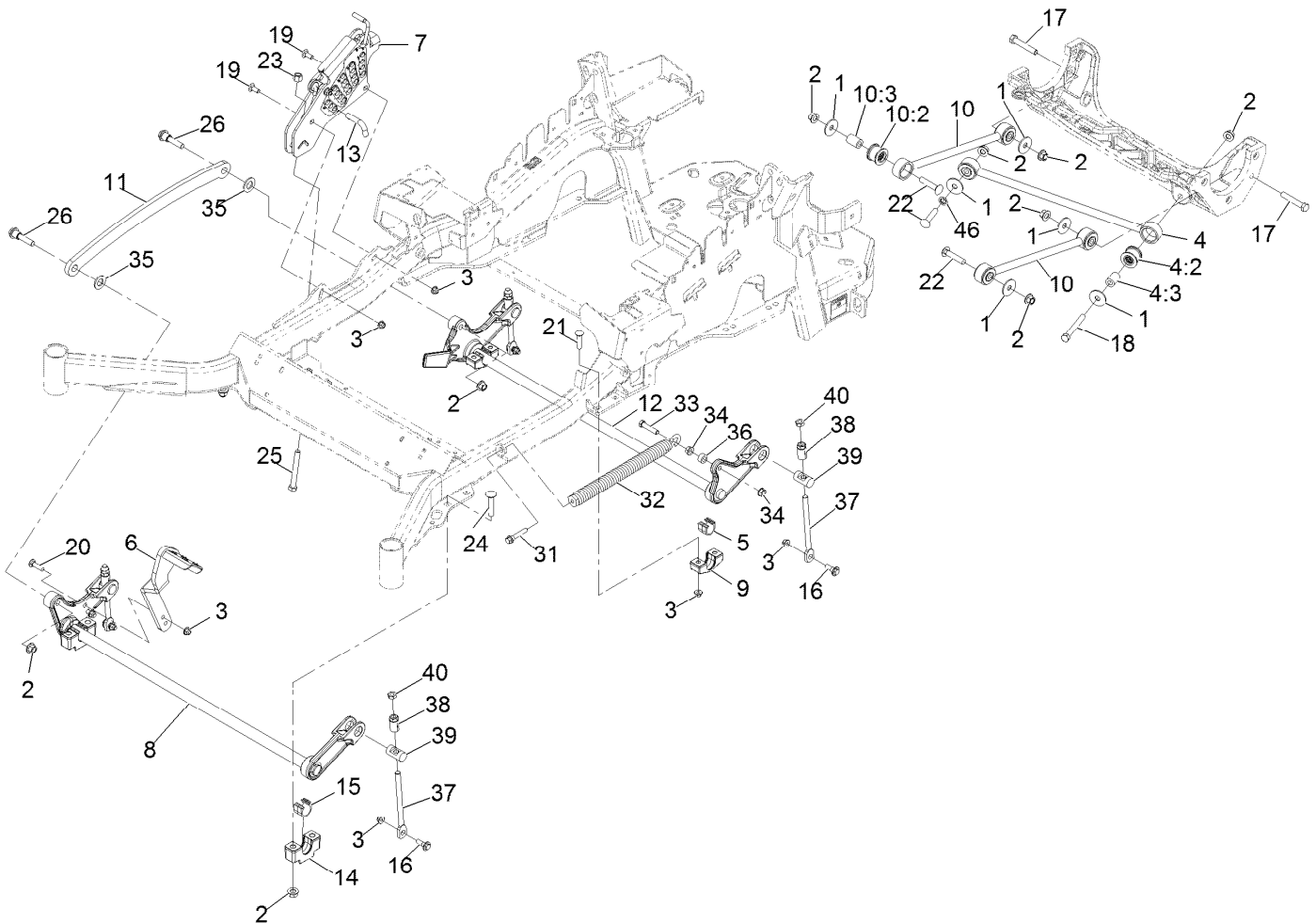

Deck Lift Assembly

Ref.	Part Number	Qty.	Description	Ref.	Part Number	Qty.	Description
1	86-1990	6	Washer	17	325-12	2	Screw-HH 1/2-13 X 3
2	99-5107	12	Nut-Lock 1/2-13	18	325-17	1	Screw-HH 1/2-13 X 4
3	104-8301	12	Nut-Nyloc 3/8-16 Flg	19	3231-2	2	Bolt-Carriage 3/8-16 X 1
4	109-5013	1	Panhard Rod ASM	20	3231-4	2	Bolt-Carriage 3/8-16 X 1 1/2
4:2	109-5009	2	Bushing-Suspension, Rubber	21	3231-5	4	Bolt-Carriage 3/8-16 X 1 3/4
4:3	109-5010	2	Spacer	22	3233-34	3	Bolt-Carriage 1/2-13 X 2 1/2
5	109-7173	2	Bearing-Cross Shaft, Rear	23	3296-23	1	Nut-Nyloc 1/2-13
6	116-1919-01	1	Lever-Foot	24	116-1700	4	Bolt-Carriage 1/2-13 X 2 1/2 Spl Neck
7	109-7438	1	HOC ASM	25	116-0559	1	Bolt-HH 1/2-13 X 4 Tap
8	126-2477-03	1	Decklift-Front	26	116-2022	2	Screw-Hex Flange 1/2-13 X 1.90
9	116-0818-03	2	Support-Cross Shaft, Rear Bearing	31	92-7674	1	Screw-Shcs 3/8-16 X 2.212
10	109-7952	2	Deck Strut ASM	32	116-0000	1	Extension Spring ASM
10:2	109-5009	2	Bushing-Suspension, Rubber	33	109-9065	1	Screw-HH 7/16-14 X 2
10:3	109-5010	2	Spacer	34	32128-37	2	Nut-Whizlock 7/16-14
11	116-0797-03	1	Link-Lift, Deck	35	3256-28	2	Washer-3/4 Sae
12	116-2645-03	1	Lift-Deck, Rear	36	116-2695	1	Spacer
13	116-5584	1	Pin-HOC	37	109-8007	4	Link-Adjuster, Deck Lift
14	109-9409	2	Support-Cross Shaft, Front Bearing	38	109-7840	4	Adjuster-Lift, Deck
15	109-9410	2	Bearing-Cross Shaft, Front	39	109-8353	4	Trunnion
16	109-9840	4	Screw-Hex Flange 3/8-16 X .80	40	3218-5	4	Nut-Jam 1/2-13
				46	126-2916	1	Nut, Push 1/2-13

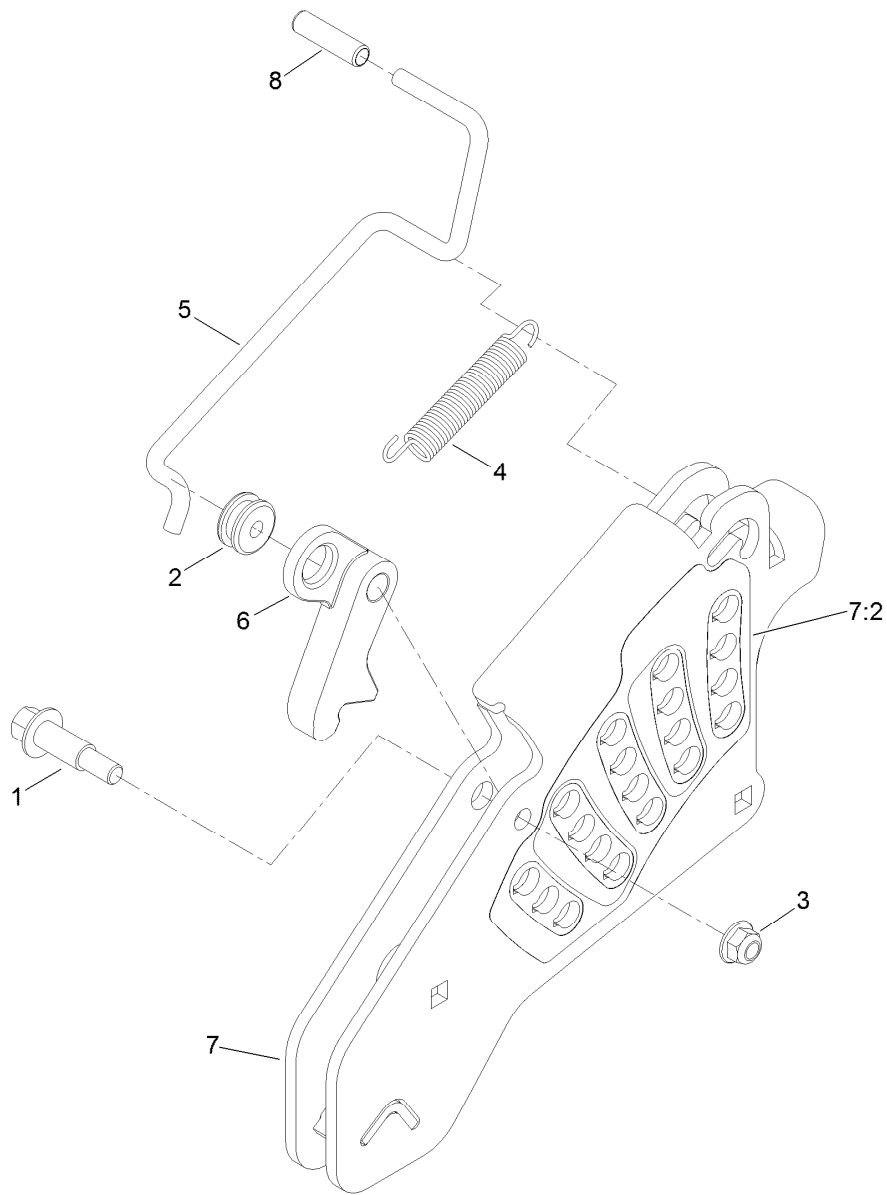

Height-of-Cut Assembly No. 109-7438

<i>Ref.</i>	<i>Part Number</i>	<i>Qty.</i>	<i>Description</i>
1	62-1330	1	Bolt-Shoulder
2	109-7130	1	Grommet
3	104-8301	1	Nut-Flange, NI
4	109-7124	1	Spring-Extension
5	109-7128	1	Rod-Lock, Transport
6	116-0118	1	Pawl-Transport, HOC
7	109-7335	1	HOC Plate ASM
7:2	116-0752	1	Decal-HOC
8	109-8250	1	Grip-Lever

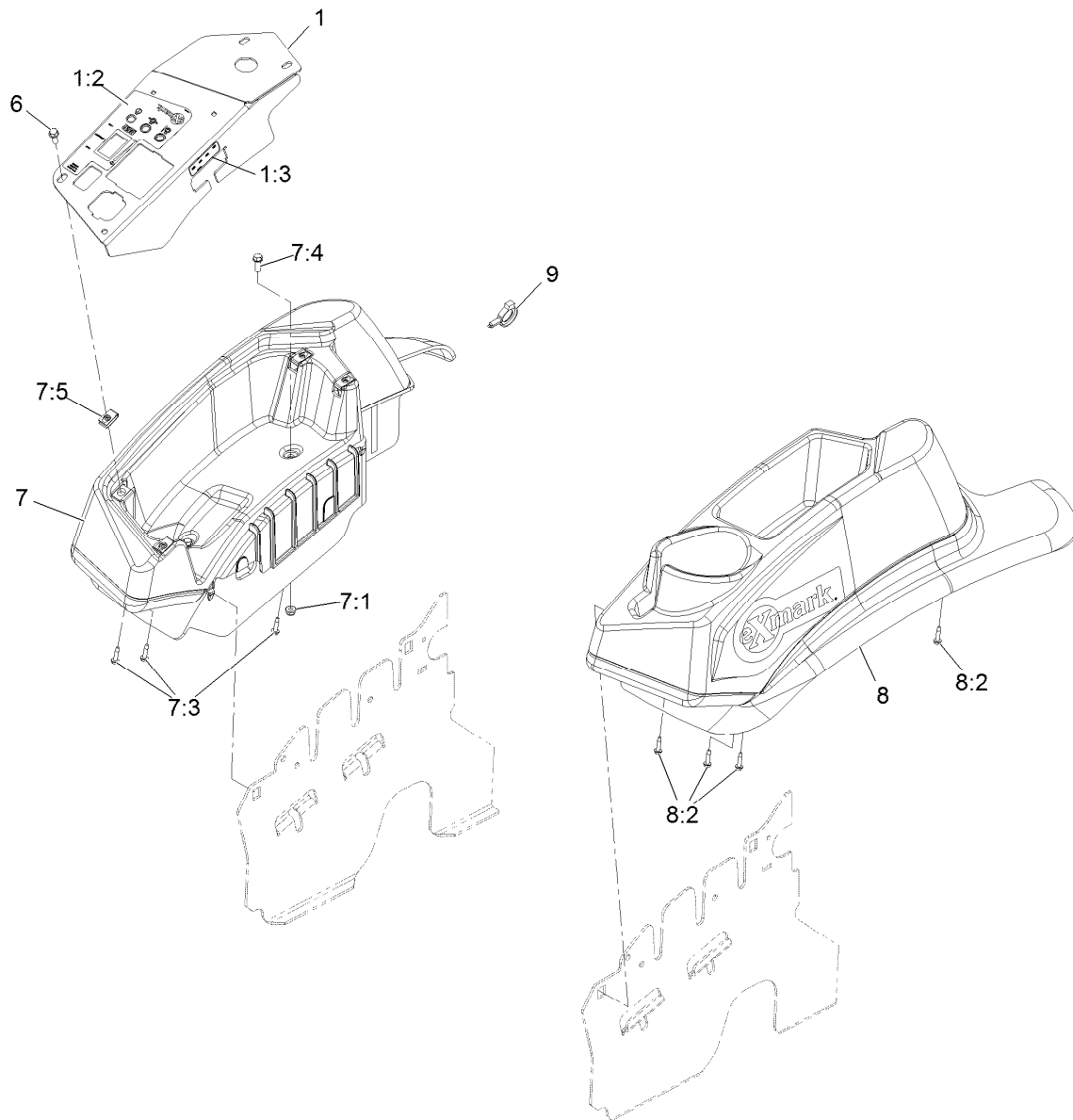

Controls Assembly

Ref.	Part Number	Qty.	Description
1	116-9416	1	Control Panel W/Decal
1:2	116-9121	1	Decal-E-Gov Control
1:3	109-7330	1	Decal-Fuse
6	32105-15	4	Screw-Machine 1/4-20 X 3/4
7	109-9341	1	Console,RH Narrow ASM
7:1	104-7201	2	Nut-Nyloc 1/4-20 Flg
7:3	109-9345	3	Screw-HWH #10-14 X 3/4 Tf
7:4	32105-15	2	Screw-Machine 1/4-20 X 3/4
7:5	107069	4	Nut-Retainer-Panel 1/4-20
8	109-9342	1	Console.LH Narrow ASM
8:2	109-9345	4	Screw-HWH #10-14 X 3/4 Tf
9	105-1853	1	Clamp-Hose

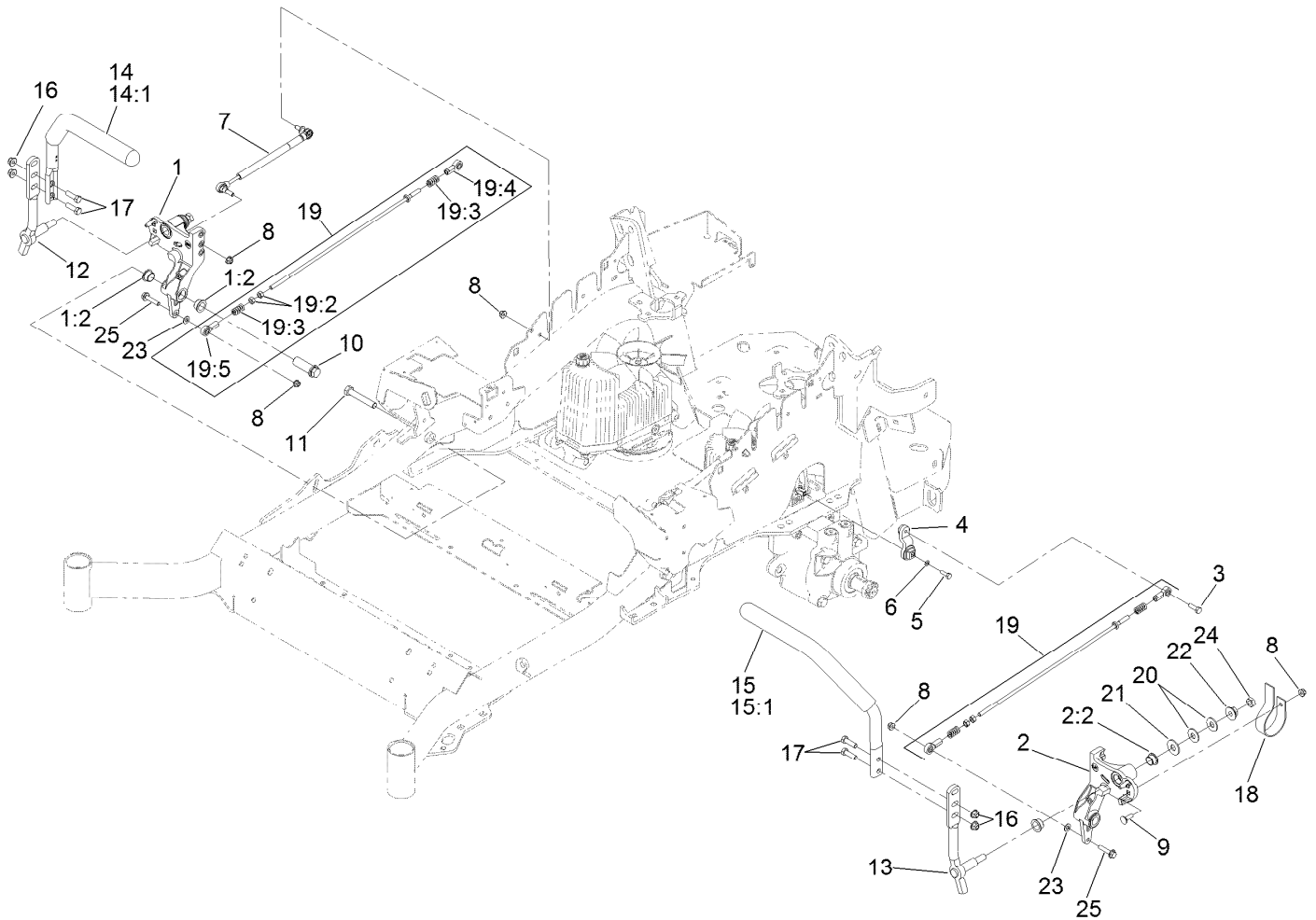

Motion Control Assembly

Ref.	Part Number	Qty.	Description	Ref.	Part Number	Qty.	Description
1	116-0880	1	RH Motion Control And Bushing ASM	14	109-6589	1	RH Steering Handle ASM
1:2	109-8054	4	Bushing-Flange	14:1	109-5668	1	Grip-Control, Lever
2	116-0881	1	LH Motion Control And Bushing ASM	15	109-6590	1	LH Steering Handle ASM
2:2	109-8054	4	Bushing-Flange	15:1	109-5668	1	Grip-Control, Lever
3	116-0648	2	Screw-HH, Thread Locking ●	16	104-8301	4	Nut-Flange, NI
4	109-4581	2	Arm-Control, Pump	17	323-7	4	Screw-HH
5	9080046	2	Screw-HH ●	18	109-5575	2	Spring-Leaf
6	1-303435	2	Washer-Spring	19	109-8106	2	Front Pump Linkage ASM
7	116-0027	2	Damper-Control, Motion	19:2	3219-2	2	Nut-Hex
8	104-8300	8	Nut-Flange, NI	19:3	1-323245	2	Spring-Compression
9	3230-2	2	Bolt-CARR	19:4	1-633152	1	Balljoint-LH
10	109-5891	2	Hub-Threaded	19:5	1-543017	1	Balljoint-RH
11	325-12	2	Screw-HH	20	109-9505	4	Washer-Spring
12	116-0039	1	Lever-Control Motion, RH	21	3256-6	2	Washer-Flat
13	116-0040	1	Lever-Control Motion, LH	22	32128-56	2	Nut-HF
				23	3256-23	2	Washer-Flat
				24	3218-5	2	Nut-Jam
				25	115-1794	2	Screw-HHF

● Use Pro-Lock, Nut Type (P/N 1-840022, .5ml tube) on threads.

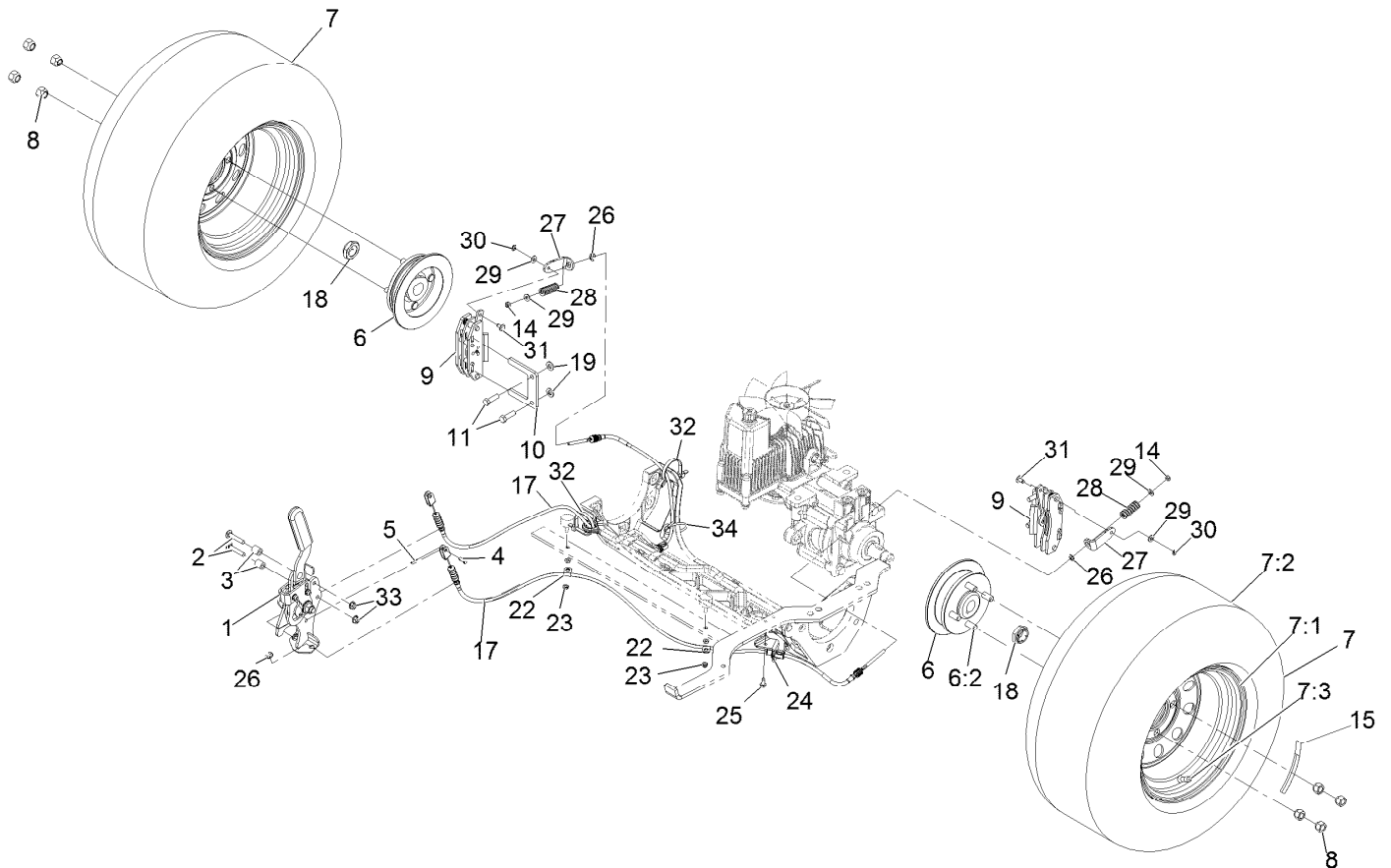

Rear Wheel and Park Brake Assembly

Ref.	Part Number	Qty.	Description	Ref.	Part Number	Qty.	Description
1	116-7551	1	Brake Handle ASM	15	126-2055	2	Decal-Torque Wheel Lug-Hub
2	116-0629	2	Screw-Carriage 5/16-18 X 1 3/4 Short	17	116-8963	2	Cable-Brake
3	82-6840	2	Spacer	18	116-1399	2	Locknut
4	60-1730	2	Pin-Clevis	19	3256-24	4	Washer-3/8 Sae
5	3272-1	2	Pin-Cotter 1/16 X 1/2	22	88-7970	2	Clip
6	116-1746	2	Wheel Hub ASM	23	3296-56	2	Nut-Nyloc 1/4-20 Thin
6:2	116-1696	4	Stud-Wheel	24	116-6397	1	Bracket-Cable
7	109-8972	2	Wheel And Tire ASM	25	32144-10	1	Screw-HWH 1/4-20 X .62
7:1	1-633993	1	Tire	26	32120-18	4	E-Ring
7:2	109-3156	1	Rim	27	116-6182	2	Bracket-Brake, L
7:3	232-27	1	Stem-Valve	28	116-6347	2	Spring-Die
8	242-50	8	Nut-Lug 1/2-20	29	3256-22	4	Washer-1/4 Sae
9	109-2889	2	Caliper-Brake	30	32151-86	2	E-Ring
10	109-0958	2	Plate-Mount, Brake	31	116-6348	2	Pin-Brake
11	92-5727	4	Screw-HH 3/8-16 X 1 1/4 Patch Lock	32	3334-945	2	Tie-Cable
14	3296-13	2	Nut-Nyloc 1/4-28	33	104-8300	2	Nut-Nyloc 5/16-18 Flg
				34	116-0940	1	Tie-Cable

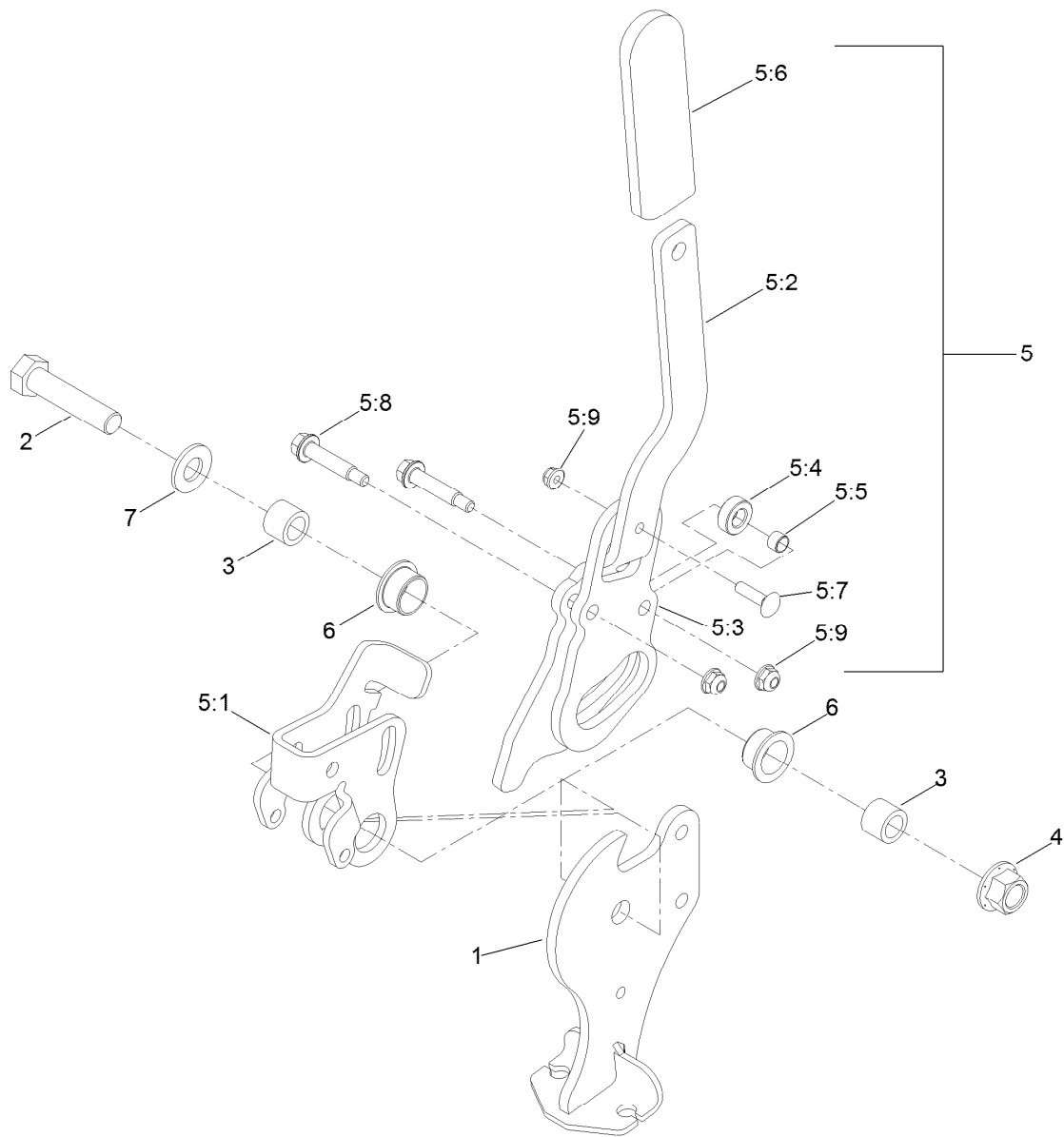

Parking Brake Handle Assembly No. 116-7551

<i>Ref.</i>	<i>Part Number</i>	<i>Qty.</i>	<i>Description</i>	<i>Ref.</i>	<i>Part Number</i>	<i>Qty.</i>	<i>Description</i>
1	116-7263	1	Pivot-Brake	5:4	116-6846	1	Roller-Brake
2	325-9	1	Screw-HH 1/2-13 X 2 1/4	5:5	116-6852	1	Bearing-Sleeve
3	116-5384	2	Spacer	5:6	1-633268	1	Grip-Lever
4	99-5107	1	Nut-Lock 1/2-13	5:7	3229-2	1	Bolt-Carriage 1/4-20 X 1
5	116-6860	1	Handle ASM	5:8	116-6876	2	Screw-Shoulder
5:1	116-6856	1	Bellcrank-Brake	5:9	104-7201	3	Nut-Nyloc 1/4-20 Flg
5:2	116-6857	1	Handle-Brake	6	109-8054	2	Bushing-Flanged
5:3	116-6858	1	Plate-Handle	7	3256-26	1	Washer-1/2 Sae

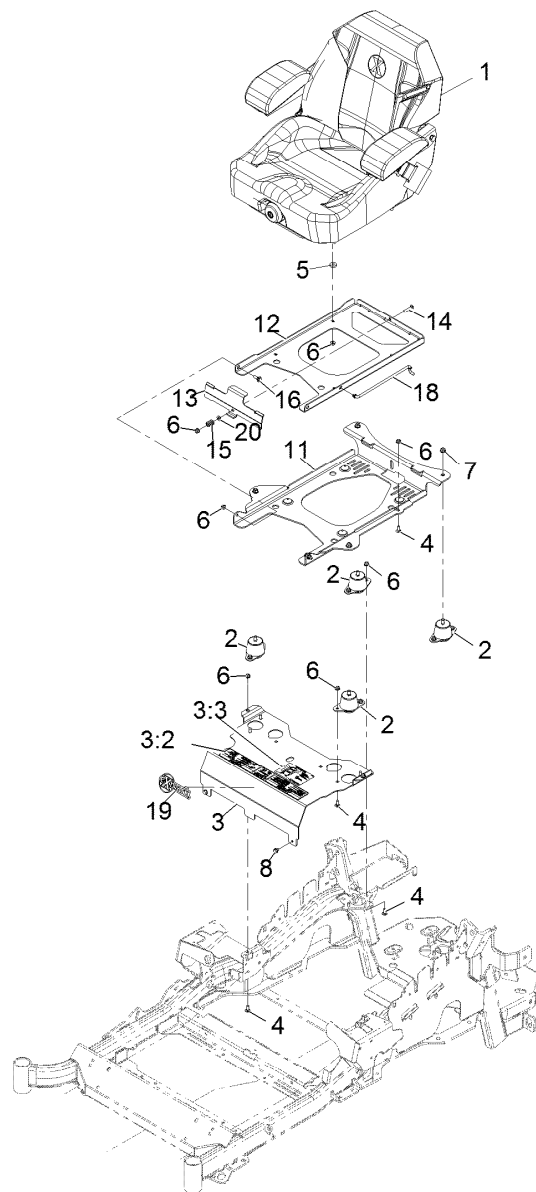

Seat Assembly

<i>Ref.</i>	<i>Part Number</i>	<i>Qty.</i>	<i>Description</i>	<i>Ref.</i>	<i>Part Number</i>	<i>Qty.</i>	<i>Description</i>
1	116-8912	1	Kit-Suspension Seat	11	116-3860-03	1	Plate-Tilt, Seat Support
2	109-9034	4	Isolator-Seat	12	116-3859-03	1	Plate-Seat, Frame
3	116-2323	1	Mount-Seat	13	109-9881-03	1	Plate-Latch, Seat
3:2	109-7069	1	Decal-Console	14	3230-4	1	Bolt-Carriage 5/16-18 X 1 1/2
3:3	116-0211	1	Decal-Service Aid	15	107-3017	1	Spring-Compression
4	3230-23	11	Bolt-Carriage 5/16-18 X 3/4 Short Neck	16	116-1297	2	Screw-Shoulder
5	26-4840	4	Spacer-Pin, Mounting	18	116-0070	1	Rod-Prop
6	104-8300	18	Nut-Nyloc 5/16-18 Flg	19	103-2883	1	Decal, Exmark Logo
7	104-8301	4	Nut-Nyloc 3/8-16 Flg	20	3256-23	1	Washer-5/16 Sae
8	9266934	2	Screw-HWH 5/16 X 1/2 Tf				

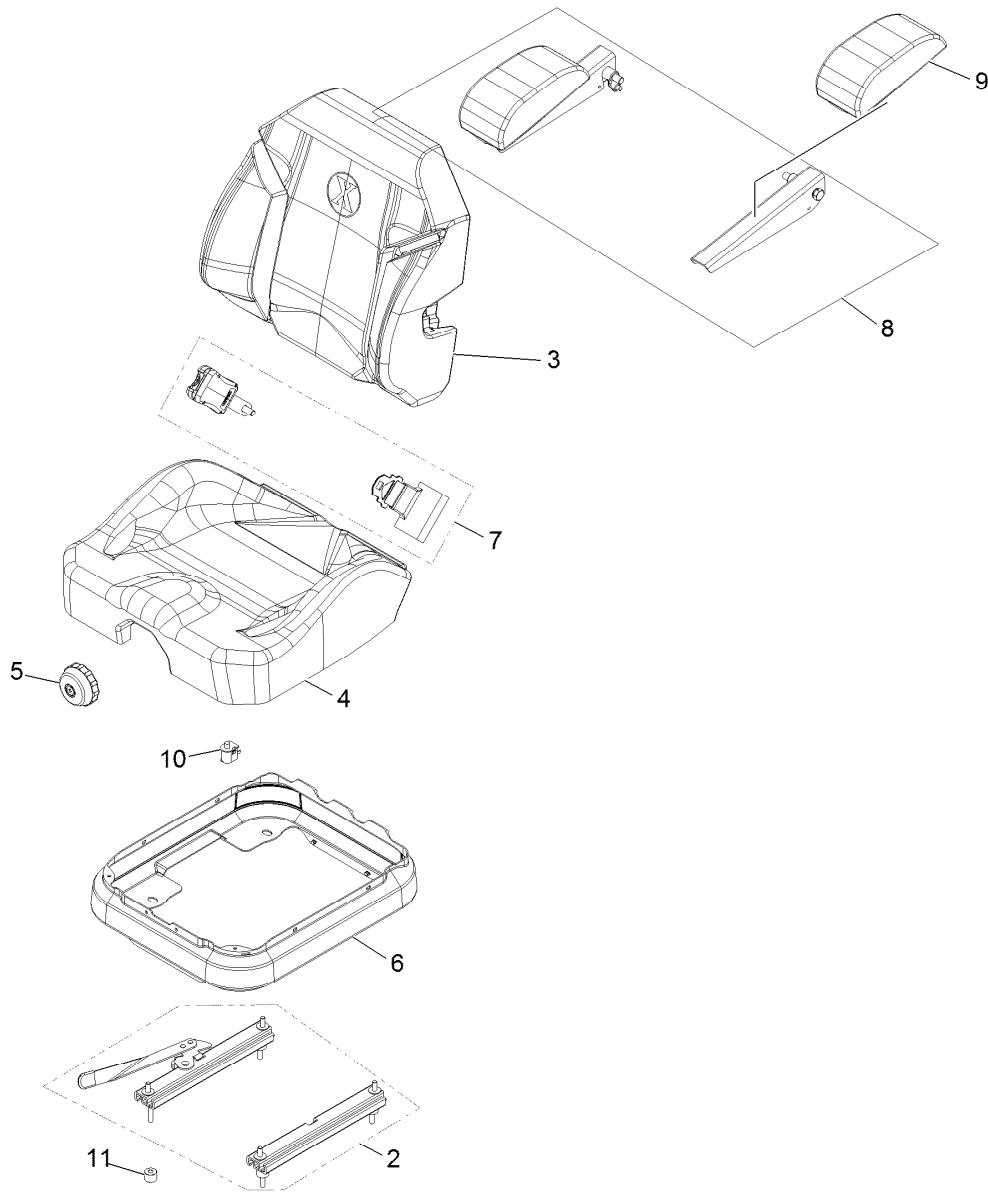

Seat W/Tracks Assembly No. 116-8912

<i>Ref.</i>	<i>Part Number</i>	<i>Qty.</i>	<i>Description</i>
2	116-8910	1	Seat Track Set
3	116-8908	1	Cover-Back 311463Vn500
4	116-8909	1	Cover-Cushion 311464Vn500
5	116-8911	1	Knob-Adjuster
6	116-5659	1	Cover-Suspension Bellows
7	109-9805	1	Seat Belt Kit
8	116-8906	1	Kit-Arm Rest Set
9	116-8905	1	Kit-Arm Rest Pads
10	82-2190	1	Switch
11	116-9329	4	Spacer

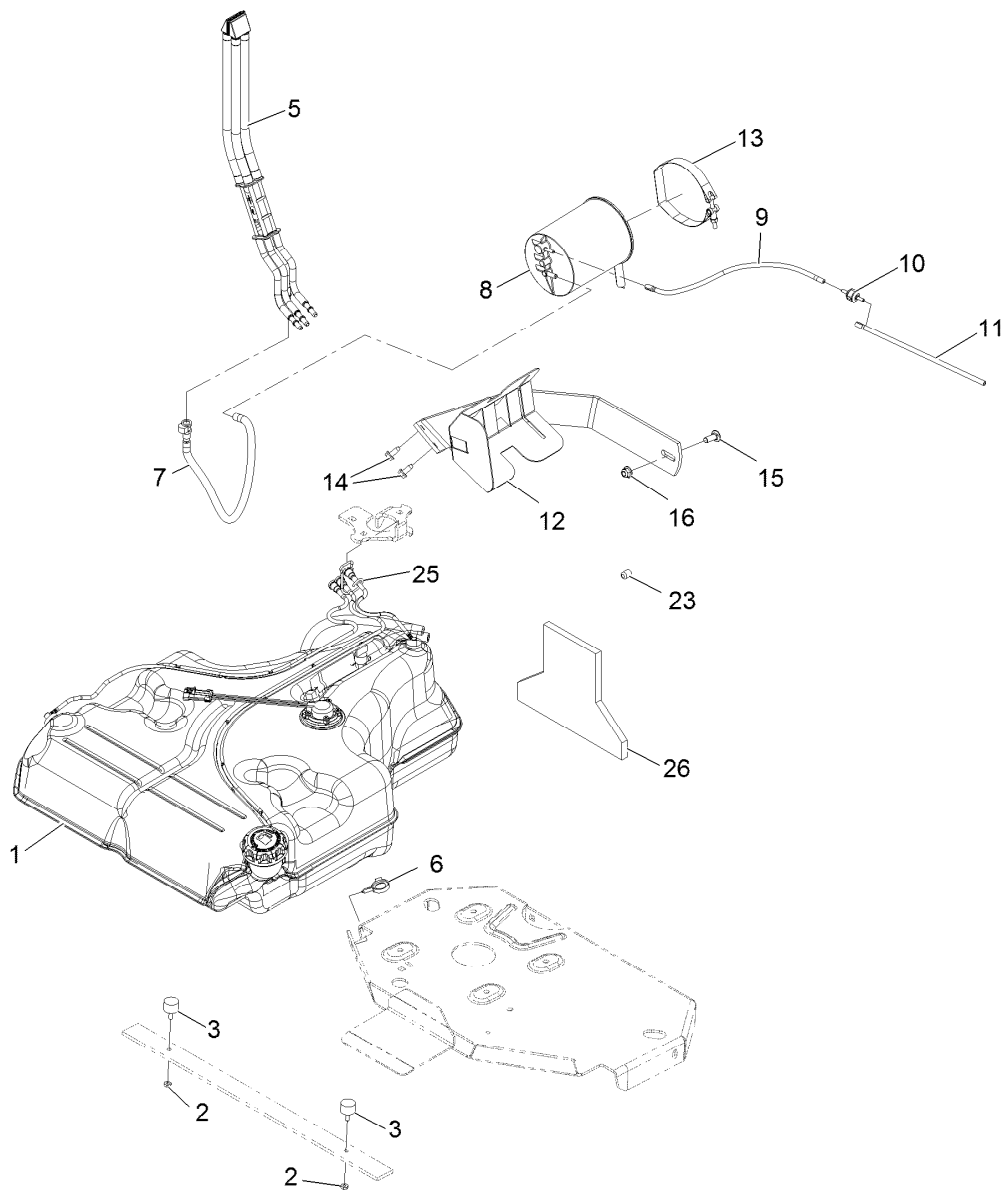

Fuel Tank Assembly

<i>Ref.</i>	<i>Part Number</i>	<i>Qty.</i>	<i>Description</i>	<i>Ref.</i>	<i>Part Number</i>	<i>Qty.</i>	<i>Description</i>
1	116-3979	1	Fuel Tank ASM	12	116-1433-03	1	Mount-Canister
2	3218-1	2	Nut-Jam	13	116-2228	1	Clamp-T-Bolt
3	116-6380	2	Bumper-Rubber (W/ Stud)	14	32144-70	2	Screw-HWH 5/16-18 X 3/4 Tf
5	109-9491	1	Fuel Manifold Vent ASM	15	3231-22	1	Bolt-Carriage 3/8-16 X 1
6	105-1853	1	Clamp-Hose	16	104-8301	1	Nut-Nyloc 3/8-16 Flg
7	116-1702	1	Vent Hose ASM	23	116-4464	1	Plug-Port
8	116-1442	1	Canister-Carbon, 1200Cc	25	116-6005	1	Retainer-Vapor Line
9	116-2963	1	Hose-Vent, Formed	26	126-0224	1	Insulation-Fuel Tank Foam
10	115-7868	1	Valve-Check, Vacuum				
11	119-4235	1	Hose-Vent, Formed				

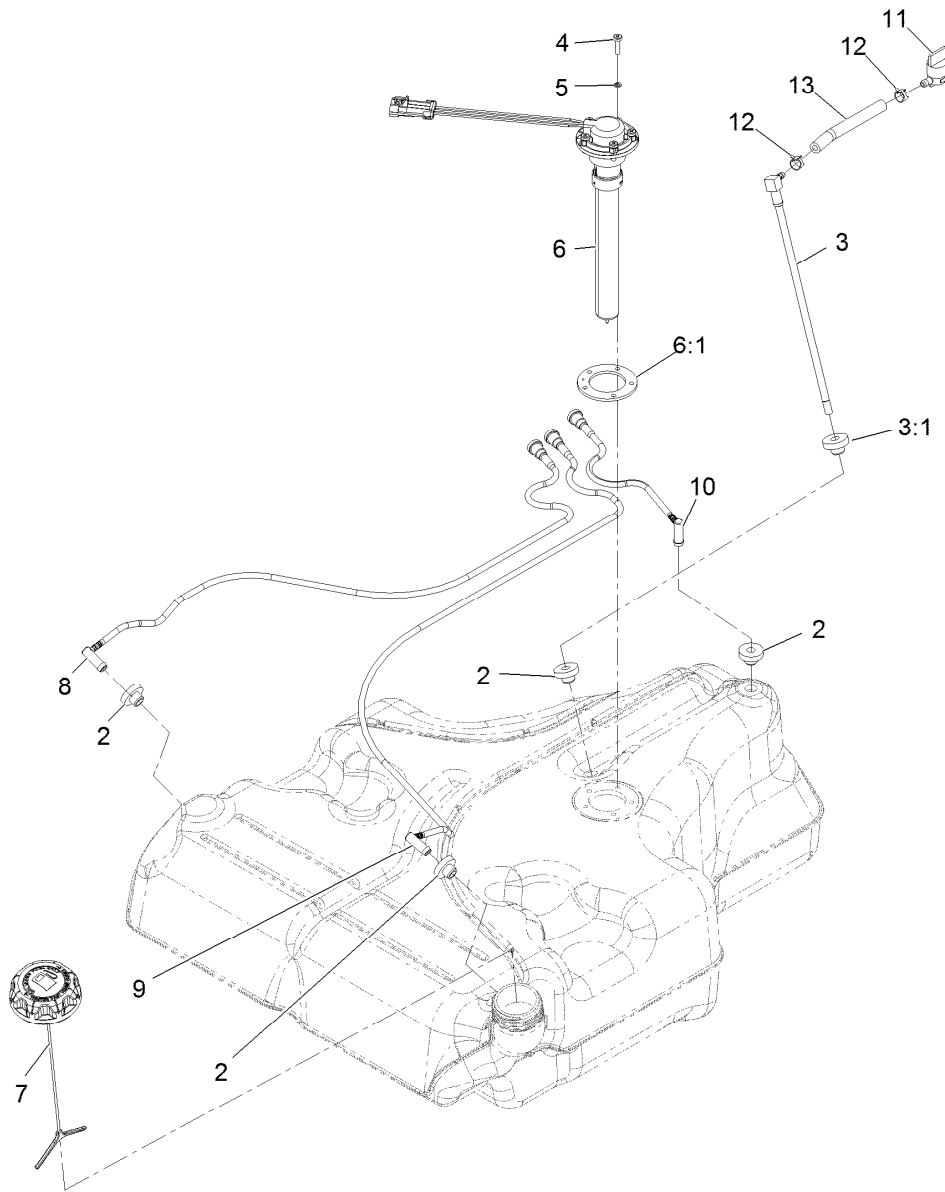

Fuel Tank Assembly No. 116-3979

Ref.	Part Number	Qty.	Description
2	46-6560	4	Bushing
3	116-2459	1	Fuel Line Kit (With Grommet)
3:1	46-6560	1	Bushing
4	9107944	5	Screw-Pan 10-24 X 3/4
5	3253-17	5	Washer-Lock 3/16
6	116-0003	1	Sender-Fuel Level
6:1	109-9620	1	Gasket-Sender, Fuel
7	126-1789	1	Cap-Fuel, Ratcheting
8	116-2460	1	RH Vent Line Kit (With Grommet)
9	116-2461	1	LH Vent Line Kit (With Grommet)
10	116-2462	1	Rear Vent Line Kit (With Grommet)
11	1-603770	1	Valve-Fuel
12	2412-98	2	Clamp-Hose
13	109-0650	1	Hose-Fuel

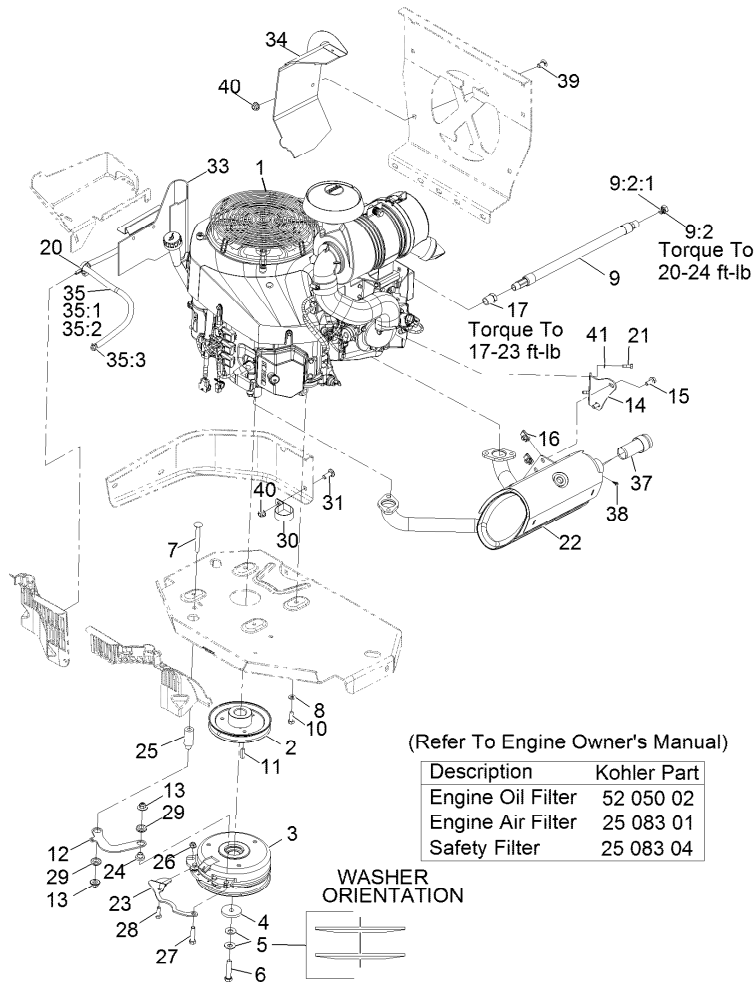

Engine Assembly

Ref.	Part Number	Qty.	Description	Ref.	Part Number	Qty.	Description
1		1	Engine-Kohler, Ecv940 Efi-Egov ●■	22	116-7552	1	Muffer
2	109-9905	1	Sheave	23	116-3331-01	1	Belt-Guide
3	116-1621	1	Clutch Kit	24	116-3318	1	Spacer
4	109-6919	1	Washer-Clutch	25	116-3319	1	Spacer
5	1-603610	2	Washer-Spring Disc 7/16	26	104-8300	1	Nut-Nyloc 5/16-18 Flg
6	109-9761	1	Screw-HH 7/16-20 X 1 1/2 W/Loctite ▲	27	323-8	1	Screw-HH 3/8-16 X 1 1/2
7	3231-42	1	Bolt-Carriage 3/8-16 X 3	28	322-4	1	Screw-HH 5/16-18 X 7/8
8	1-303334	4	Washer-Spring Disc 5/16	29	93-5108	2	Grommet-Rubber
9	116-5316	1	Oil Drain Hose ASM	30	2412-147	1	Clamp
9:2	353-508	1	Plug-W/O-Ring	31	3231-22	1	Bolt-Carriage 3/8-16 X 1
9:2:1	237-42	1	O-Ring	33	126-0212	1	Baffle-RH
10	33114-025	4	Screw-HH M8-1.25 X 25Mm	34	126-0215	1	Baffle-Rear
11	1-807259	1	Key-Machine 1/4 X 1/4 X 1	35	126-1414	1	Fuel Line ASM
12	116-3317-01	1	Link-Anchor, Clutch	35:1	109-0286	1	Hose-Fuel Line 35"
13	109-6658	2	Nut-Nyloc 3/8-16 Flg	35:2	126-1417	1	Sleeve-Thermal
14	116-9048	1	Bracket-Muffer	35:3	2412-98	2	Clamp-Hose
15	3234-5	2	Screw-HH Flg 5/16-18 X 3/4	37	126-0268	1	Arrestor-Spark
16	94-2413	2	U-Nut	38	126-0275	1	Screw-HWH
17	103-1390	1	Bushing	39	3231-21	1	Bolt-Carriage 3/8-16 X 3/4
20	105-1853	1	Clamp-Hose	40	104-8301	2	Nut-Nyloc 3/8-16 Flg
21	116-4295	2	Screw-HH M6-1 X 20Mm W/Patch	41	1-303435	2	Washer-Spring Disc 1/4

● Not serviced separately

▲ Use Pro-Lock, Nut Type (P/N 1-840022, .5ml tube) on threads.

■ Obtain parts from www.kohlerplus.com

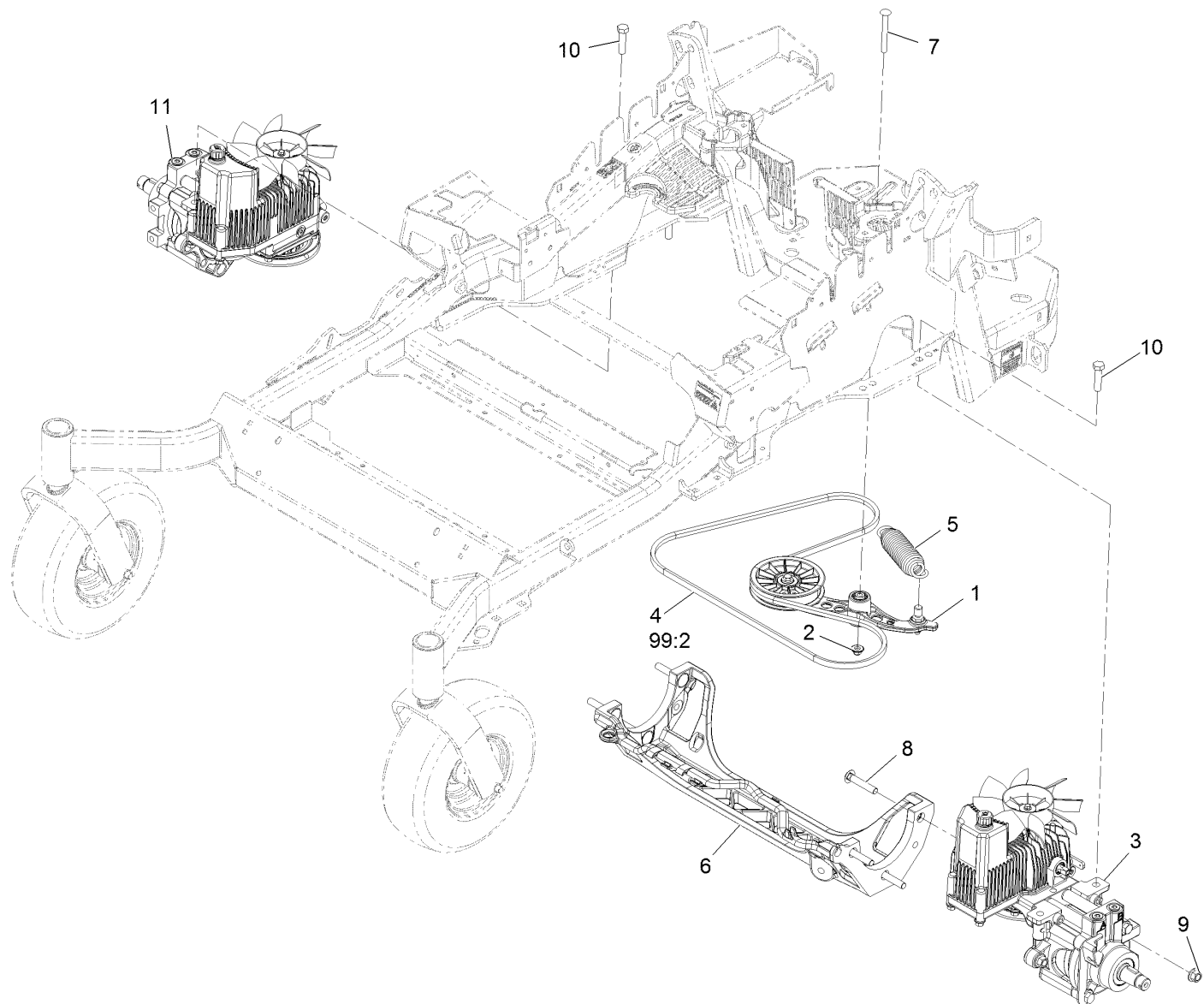

Hydraulic Assembly

Ref.	Part Number	Qty.	Description	Ref.	Part Number	Qty.	Description
1	116-1255	1	Pump Idler ASM	10	325-8	4	Screw-HH 1/2-13 X 1 1/4
2	109-6658	1	Nut-Nyloc 3/8-16 Flg	11	116-6410	1	RH Hydro ASM (16Cc W/Shock)
3	116-6409	1	LH Hydro ASM (16Cc W/Shock)	99	109-9828	1	Bottle-Oil, 32Oz Hydraulic ●
4	109-3388	1	Belt	99	116-0164	1	Filter-Hydro ●
5	116-6317	1	Spring-Extension	99	116-1218	1	Bottle, Oil 1 Gallon Hydraulic ●
6	109-9375	1	Cradle-Hydro	99	116-3270	1	Kit, Hydro Service ●
7	116-1502	1	Bolt-Carriage Shoulder 3/8-16 X 3 1/2	99:1	109-9828	4	Bottle-Oil, 32Oz Hydraulic ●
8	126-0095	6	Screw-CARR	99:2	109-3388	1	Belt
9	99-5107	6	Nut-Lock 1/2-13	99:3	116-0164	2	Filter-Hydro ●

● Not illustrated

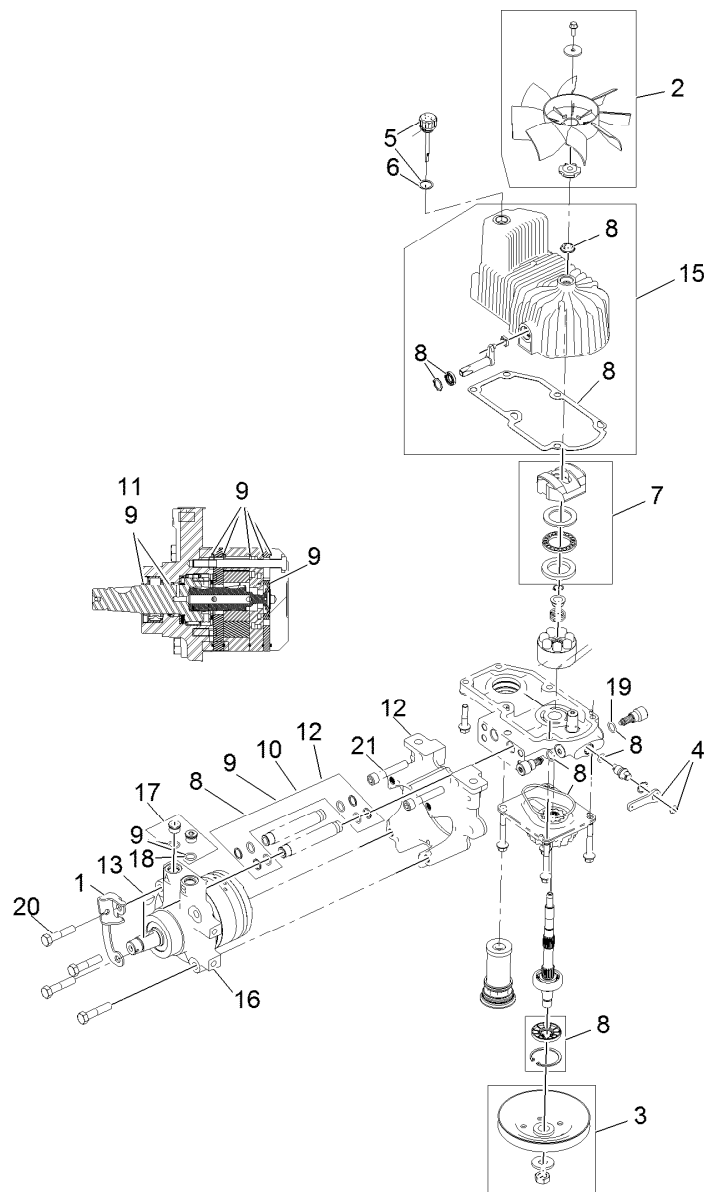

LH Hydro Assembly No. 116-6409

Ref.	Part Number	Qty.	Description	Ref.	Part Number	Qty.	Description
1	116-6859	1	Bracket-Anchor, Cable	11	116-1371	1	Output Shaft Seal Kit
2	116-0233	1	Fan Kit	12	116-5469	1	Nose Cup-Uht
3	116-0234	1	Pulley Kit	13	3257-42	1	Key-Woodruff 5/16 X 1
4	116-0235	1	Handle-Bypass Valve, Hydro	15	115-3287	1	Housing-Hydro LH
5	116-0236	1	Dipstick-Hydro W/Gasket	16	116-8917	1	Motor-Hydraulic, LH 280Cc
6	116-0237	1	Gasket-Dipstick, Hydro	17	116-7901	1	Magnetic Plugs Service Kit
7	116-1367	1	Swash Block Kit	18	76-1900	2	O-Ring
8	116-1368	1	Pump Seal Kit	19	116-8662	2	O-Ring-Check Valve
9	116-1369	1	Motor Seal Kit	20	116-8974	4	Screw-HH 1/2-20 X 2 1/4
10	116-1370	1	Tube Seal Kit	21	116-8975	2	Screw-HSH 1/2-20 X 2 3/4
				99	116-1373	1	Flow Test Kit ●

● Not illustrated

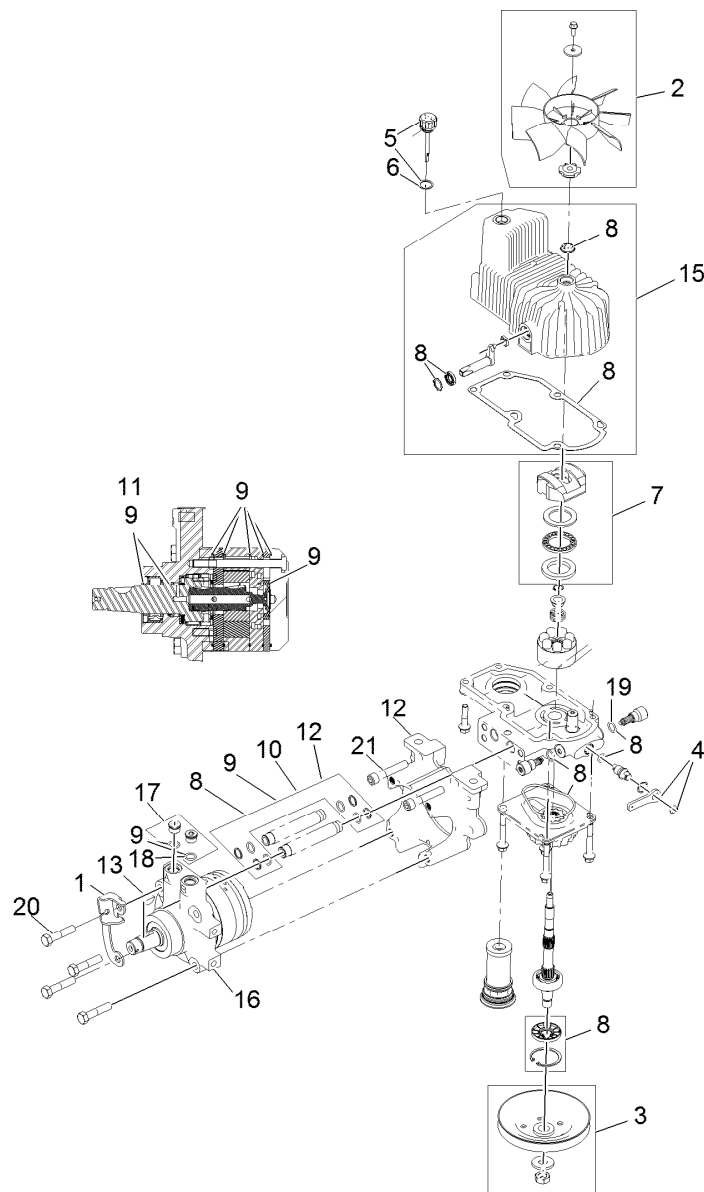

RH Hydro Assembly No. 116-6410

Ref.	Part Number	Qty.	Description	Ref.	Part Number	Qty.	Description
1	116-6859	1	Bracket-Anchor, Cable	11	116-1371	1	Output Shaft Seal Kit
2	116-0233	1	Fan Kit	12	116-5469	1	Nose Cup-Uht
3	116-0234	1	Pulley Kit	13	3257-42	1	Key-Woodruff 5/16 X 1
4	116-0235	1	Handle-Bypass Valve, Hydro	15	116-3288	1	Housing-RH
5	116-0236	1	Dipstick-Hydro W/Gasket	16	116-8918	1	Motor-Hydraulic, RH 280Cc
6	116-0237	1	Gasket-Dipstick, Hydro	17	116-7901	1	Magnetic Plugs Service Kit
7	116-1367	1	Swash Block Kit	18	76-1900	2	O-Ring
8	116-1368	1	Pump Seal Kit	19	116-8662	2	O-Ring-Check Valve
9	116-1369	1	Motor Seal Kit	20	116-8974	4	Screw-HH 1/2-20 X 2 1/4
10	116-1370	1	Tube Seal Kit	21	116-8975	2	Screw-HSH 1/2-20 X 2 3/4
				99	116-1373	1	Flow Test Kit ●

● Not illustrated

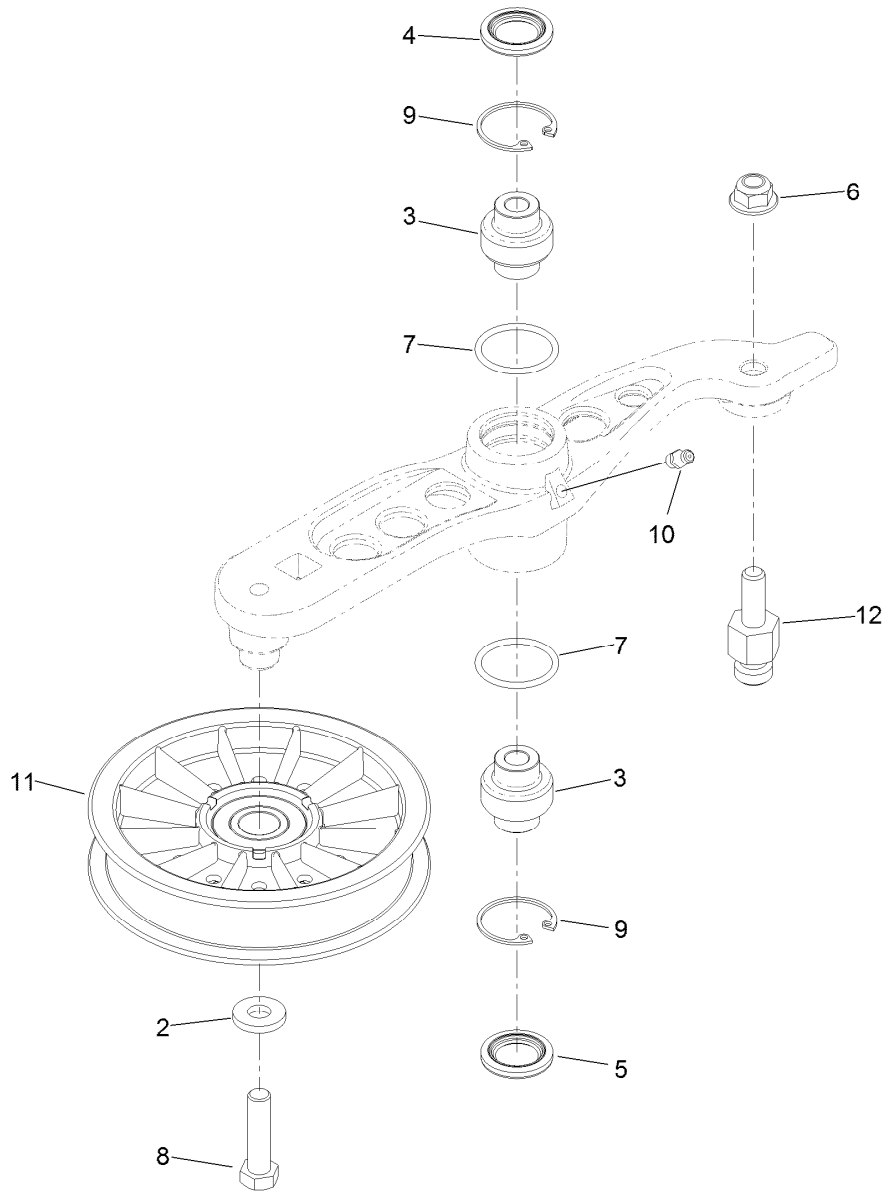

Pump Idler Assembly No. 116-1255

Ref.	Part Number	Qty.	Description
2	43-0940	1	Spacer
3	103-3504	2	Bearing-Spherical
4	103-3505	1	Seal-Double Lip
5	103-3506	1	Seal-Single Lip
6	109-6658	1	Nut-Flange, NI
7	106-7159	2	O-Ring
8	323-8	1	Screw-HH
9	32120-10	2	Ring-Snap
10	302-19	1	Fitting-Grease
11	109-8076	1	Pulley-Idler
12	116-3467	1	Pin-Spring, Anchor

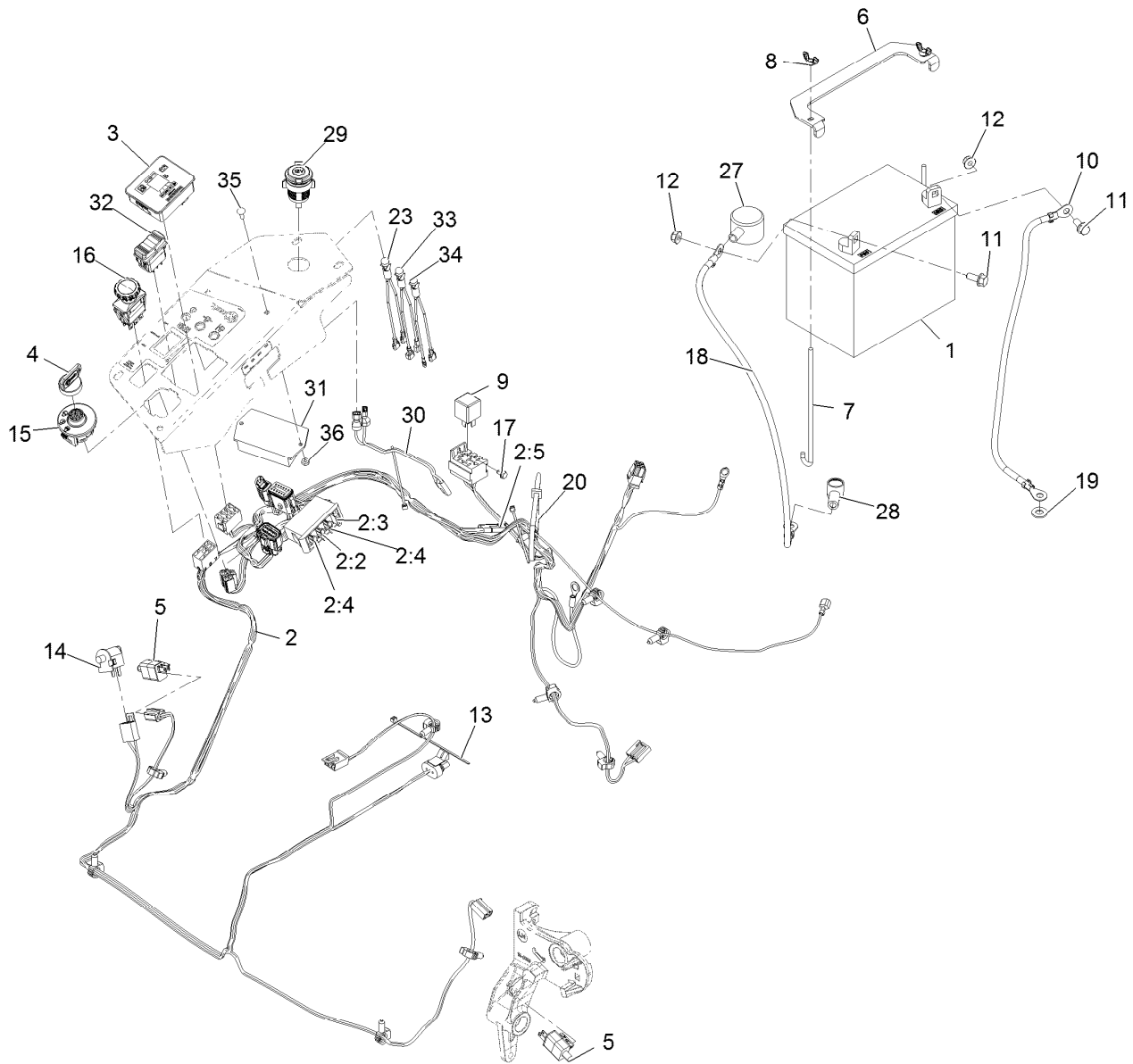

Electrical Assembly

Ref.	Part Number	Qty.	Description	Ref.	Part Number	Qty.	Description
1		1	Battery-Wet ●■	14	82-2190	1	Switch
2	126-1682	1	Harness-Wire	15	117-2221	1	Switch-Ignition
2:2	218-578	1	Fuse-Blade, 10 Amp	16	116-0124	1	Switch-PTO, 10A
2:3	109355	1	Fuse-Blade, 15 Amp	17	104-2065	1	Screw-HWH #10-24 X 3/8
2:4	109102	2	Fuse-Blade, 25 Amp	18	115-3864	1	Cable-Battery, Positive
2:5	116-0053	1	Cap-Plug	19	3256-24	1	Washer-3/8 Sae
3	117-3882	1	Fuel/Hour Meter ASM	20	1-303335	1	Tie-Cable 7 15/16 (Large)
4	1-603511	1	Key-Ignition	23	1-643267	1	Indicator-Red Led
4	103-2106	1	Key-Exmark Logo	27	109-2407	1	Insulator-Battery
5	110-6765	2	Switch-Single Pole No	28	1-543393	1	Insulator-Solenoid
6	116-0042-03	1	Strap-Tie Down, Battery	29	109-9376	1	Receptacle-12V
7	1-633651	2	Bolt-Holddown	30	109-9693	1	Harness, Receptacle 12V
8	1-543792	2	Wingnut-Nyloc 1/4-20	31	126-2722	1	Controller-Red
9	1-643275	1	Relay-12Vdc 40 Amp	32	116-9669	1	Switch-Rocker
10	114-1218	1	Cable-Battery, Negative	33	116-9651	1	Light-Led, Red
11	3234-5	2	Screw-HH Fig 5/16-18 X 3/4	34	116-9652	1	Light-Led, Red
12	104-8300	2	Nut-Nyloc 5/16-18 Fig	35	3229-34	2	Screw-CARR
13	1-303287	3	Tie-Cable 5 1/2 (Small)	36	3296-2	2	Nut-Nyloc #10-24

● Obtain locally.

■ Not serviced separately

Notes:

Notes:

Notes:

EXMARK® MAINTENANCE

MAXIMIZE THE PERFORMANCE OF YOUR EXMARK.

4-CYCLE PREMIUM ENGINE OIL

Part No. 116-3373

Both SAE 30 and SAE 10W-30 in one bottle.

Contains increased levels of zinc and phosphorus for better lubricity.

No Viscosity Index Improvers that tend to shear down in high heat.

Synthetic formulation.

Gas & Diesel compatible.

Anti-corrosion additives.

API 'SL' and JASO rated with wet clutch compatibility for other machines.

PREMIUM HYDRO OIL

Part No. 109-9828

Commercial quality for tough, high-heat conditions.

Designed specifically for zero-turn mower hydraulic systems.

Superior shear resistance under heavy loads.

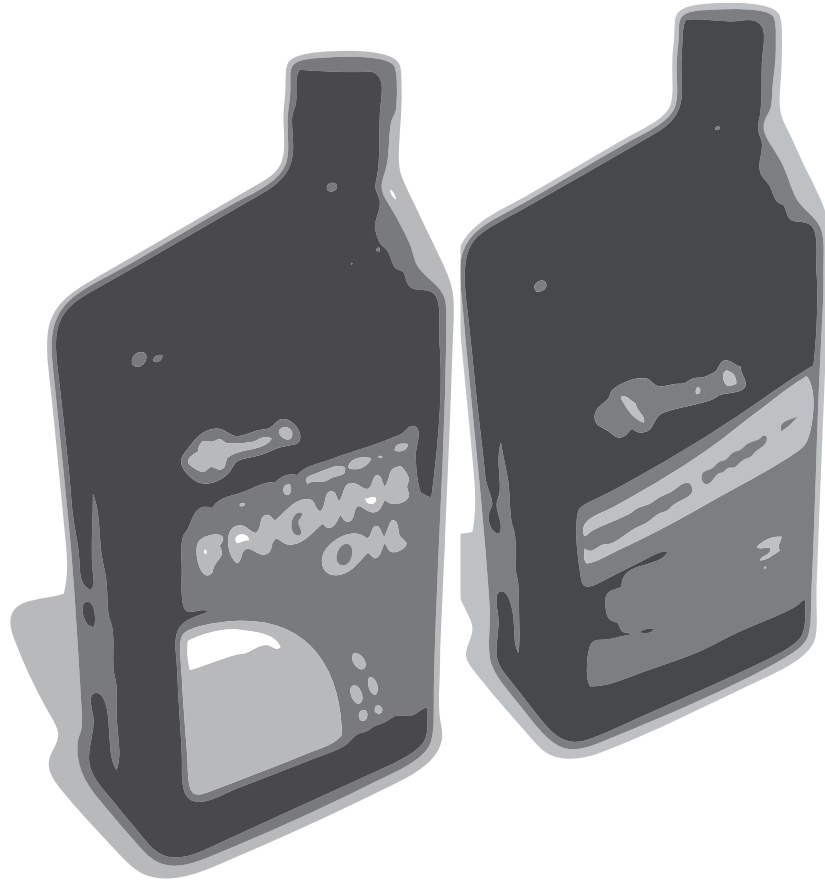

Available from your local Exmark dealer. Find your closest dealer at exmark.com

EXMARK ACCESSORIES AND OPTIONS*

MID-MOUNT RIDING ACCESSORIES AND OPTIONS

CUSTOM RIDE SEAT SUSPENSION SYSTEM	OPERATOR CONTROLLED DISCHARGE
FULL SUSPENSION SEAT	SUN SHADE
DECK LIFT ASSIST KIT	TRASH CONTAINER
HITCH KIT	TURF STRIPER
LIGHT KIT	ULTRA VAC COLLECTION SYSTEM
12V POWER PORT	ULTRA VAC QUICK DISPOSAL SYSTEM
MICRO-MULCH SYSTEM	

OUT-FRONT RIDING ACCESSORIES AND OPTIONS

CUSTOM RIDE SEAT SUSPENSION SYSTEM	SNOW BLADE
DUAL-TAIL WHEEL	SNOWBLOWER
FLOOR PAN EXTENDER	SUN SHADE
HITCH KIT	TRASH CONTAINER
LIGHT KIT	ULTRA VAC COLLECTION SYSTEM
MICRO-MULCH SYSTEM	ULTRA VAC QUICK DISPOSAL SYSTEM
ROLL OVER PROTECTION SYSTEM (ROPS)	WEATHER CAB

WALK-BEHIND ACCESSORIES AND OPTIONS

GRASS CATCHER	TURF STRIPER
MICRO-MULCH SYSTEM	STANDON

*Some accessories and options not available for some models.

Place Model No. and Serial No.
Label Here (Included in the Literature
Pack) or Fill in Below

Model No. _____

Serial No. _____

Date Purchased _____

Engine Model No. and Spec. No. _____

Engine Serial No. (E/No) _____

© 2014 Exmark Mfg. Co., Inc.
Industrial Park Box 808
Beatrice, NE 68310
All Rights Reserved

Part No. 4501-737 Rev. A
(402) 223-6300
Fax (402) 223-5489
Printed in the USA.

