

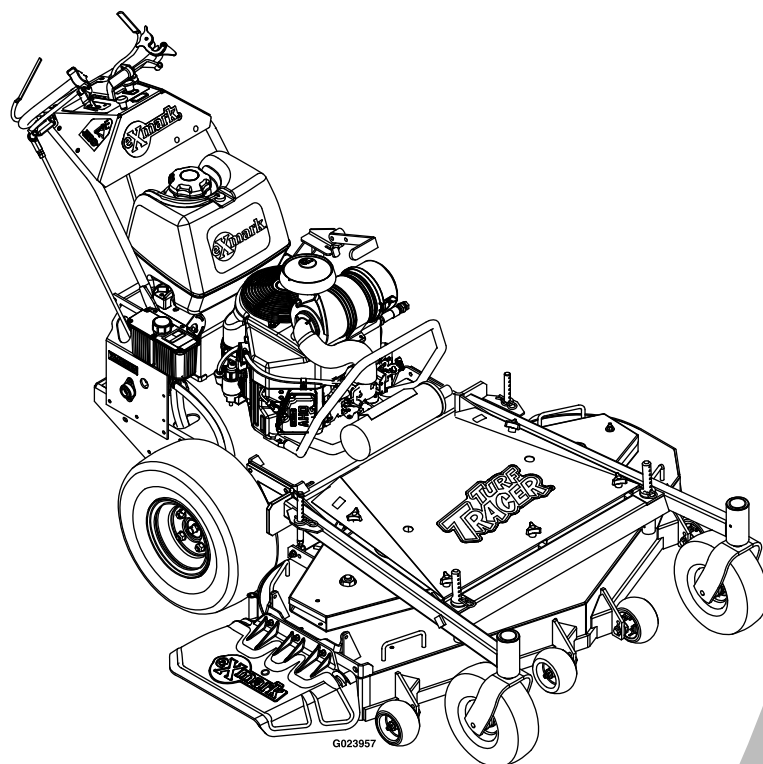

TURF TRACER® X-SERIES

Model No. TTX650EKCE604N—Serial No. 31400000 and Up

Picture below may not reflect actual product.



Parts Manual

Part No. 4501-708 Rev. B

Ordering Replacement Parts

To order replacement parts, please supply the part number, the quantity, and the description of each part desired.

Understanding Reference Numbers

Each identified part in an illustration has a reference number. The reference number for a part also appears in the parts list, along with other information about the part.

This catalog uses two special reference number formats, one to indicate parts in a service assembly and another to indicate the quantity of a given part in an illustration.

Service Assembly Reference Numbers

Parts in service assemblies have reference numbers in the form a:b. The a represents the reference number of the entire service assembly and the b represents a sequential number unique to each part within the service assembly.

For example, a wheel assembly might be identified by reference number 6, the tire by 6:1, the valve by 6:2, and the wheel by 6:3. When you order the assembly identified by reference number 6, you receive all parts identified by reference numbers 6:1, 6:2, and 6:3. However, you may also order any part individually. Reference numbers of this type appear in illustration and in parts lists.

Reference Numbers Indicating Quantity

In an illustration, if a reference number indicates more than one part, the reference number has the form nX y. The n represents the quantity of the part, the X is the multiplication symbol, and the y represents the reference number.

For example, in an illustration, the reference number 2X 37 means that two of the parts identified by reference number 37 are indicated.

List of Abbreviations

AR: as required	HJ: hex jam	PRH: phillips round head
ASM: assembly	HLH: hex lag head	PTH: phillips truss head
BBC: blade brake control	HOC: height-of-cut	PTO: power-take-off
BHTF: button head thread forming	HSBH: hex socket button head	RH: right hand
CARR: carriage	HSFH: hex socket flat head	ROPS: roll-over protection system
CCW: counter clockwise	HSH: hex socket head	RRB: rear roller brush
CW: clockwise	HWH: hex washer head	SFH: slotted fillister head
DEG: degrees	HWHTF: hex washer head thread forming	SHH: slotted hex head
DPA: Dual Point Adjustment	HYD: hydraulic	SHWH: slotted hex washer head
ECM: electronic control module	LH: left hand	SPH: slotted pan head
EXT: external	LP: Liquefied Petroleum Gas	SQH: square head
FH: flat head	LPG: Liquefied Petroleum Gas	SRH: slotted round head
GA: gauge	NI: nylon insert	STD: standard
HD: heavy-duty	NPTF: national pipe thread fine	TAP: self tapping
HF: hex flange	PFH: phillips flat head	TTH: torx truss head
HH: hex head	PPH: phillips pan head	
HHF: hex head flange	PPHTF: phillips pan head thread forming	
HHFTF: hex head flange thread forming		

Touch Up Paint

Exmark black touch up spray paint – gloss black.

Exmark red touch up paint (spray paint – P/N 1-850337 - .6 oz liquid bottle – P/N 103-9140).



If your Exmark dealer does not have the Exmark part in stock, Exmark will get the parts to the dealer the next business day or the part will be FREE Guaranteed!! (Some restrictions apply. See your participating Exmark Dealer for details.)

Contents

- Deck Assembly 4
- Deck Support Assembly 6
- ECS Upper Handle Controls Assembly..... 8
- Engine Deck Assembly 10
- Park Brake and Engine Assembly 12
- Hydraulic Assembly 14
- Fuel Tank Assembly..... 16
- Electrical Assembly 17
- Decals 18
- StandOn Assembly 19

Deck Assembly (continued)

Ref.	Part Number	Qty.	Description	Ref.	Part Number	Qty.	Description
1	109-9220	3	Screw-Sems 1/2-20 X 2.19	42	32128-20	5	Nut-Whizlock 5/16-18
2	323-6	2	Screw-HH 3/8-16 X 1	43	103-2967-01	1	Shield, Belt RH
3	98-5975	11	Washer-Spring Disc 3/8	44	103-2968-01	1	Shield, Belt LH
4	3290-357	11	Nut-Whizlock 3/8-16	45	1-603413	1	Spring-Extension
4	3290-357	17	Nut-Whizlock 3/8-16	46	109-4077	1	Pulley-Idler, Flat
5	323-8	18	Screw-HH 3/8-16 X 1 1/2	47	3234-11	2	Screw-HH Flg 3/8-16 X 1
6	3217-46	3	Nut-Hex 3/4-16 Heavy	48	3296-39	20	Nut-Nyloc 3/8-16
7	103-2802	3	Washer-Spring Disc 3/4	49	103-2916	2	Guard-Top
8	103-2794	3	Sheave, Blade Drive ▲	50	103-3506	2	Seal-Single Lip
9	103-2535	3	Spacer-Guard Bottom	51	103-8072	1	Kit, Idler Arm W/Bearings ●
10	103-9086	2	Kit-Splined Spindle ▲	52	32120-10	4	Ring-Retaining
11	109-4722	1	Asm, Discharge Chute	53	103-8071	1	Kit, Idler Arm W/Bearings ●
12	103-9087	1	Kit, Center Blade Spindle (Long) ▲	54	302-40	2	Zerk-90° 1/4-28
13	103-2982	4	Key-Machine 1/4 X 3/16 X 3/4	55	116-5950	1	Complete Deck Assy
14	103-2791	1	Sheave, Mower Drive ▲	56	1-413525	2	Link, Rear Deck Support
15	103-1330	3	Guard-Bearing Top ▲	57	1-613204	2	Balljoint
16	103-8280	3	Asm, Cutter Housing W/Bearings ▲	58	103-8415	6	Roller, Anti-Scalp
18	1-411532	2	Kit, Support Link W/Pin	59	116-9981	6	Kit, Anti-Scalp Roller
19	1-633173	1	Belt, Blade Drive	60	116-8131	6	Axle, Roller
20	323-23	1	Screw-HH 3/8-16 X 4-1/2	61	1-603620-01	1	Bracket, Spring Anchor
21	103-9083	1	Housing, Cutter Complete (Center)	62	98-5961	2	Screw-HH 3/8-16 X 4 Gr8
22	103-9076	2	Asm, Cutter Housing Complete	63	1-603414	1	Spring-Extension
23	103-3209	1	Spacer, Tube	65	1-603001	2	Rod, Deck Support
24	1-413425	2	Spacer	66	3256-24	5	Washer-3/8 Sae
25	3256-82	3	Washer	67	103-6403	3	Blade, Notched
26	323-9	2	Screw-HH 3/8-16 X 1 3/4	67	103-6383	3	Blade, Solid
27	1-603050	4	Spacer	67	103-6388	3	Blade, Low Lift
28	1-633988	1	Spacer-Anchor, Clutch	67	103-6393	3	Blade, Mulching ■
29	1-800017	2	Bolt-HH 5/16-18 X 3 1/4 Tap	67	103-6398	3	Blade, Extreme
30	1-513791	1	Bushing	68	1-806009	4	Hairpin-Cotter #206
31	3256-3	6	Washer-5/16 Std	69	1-323539	2	Spacer-Blade Drive
32	323-12	4	Screw-HH 3/8-16 X 2 1/2	70	1-806332	2	Rollpin 1/4 X 1 1/2
33	3220-3	2	Nut-Jam 3/8-24	71	103-3505	2	Seal-Double Lip
34	1-603805	1	Pulley-Idler	72	103-3504	4	Bearing-Spherical
35	1-613098	1	Pulley-Idler	73	1-413088	2	Spacer
36	116-5952	1	Deck, (116-5863-01) W/ Decals	74	106-7159	4	O-Ring
37	109-2738	1	Chute, Discharge	75	109-6658	6	Nut-Nyloc 3/8-16 Flg
38	322-5	2	Screw-HH 5/16-18 X 1	76	103-3037	3	Bushing, Splined
39	3296-29	8	Nut-Nyloc 5/16-18	77	109-4573-01	1	Bracket, Discharge Chute
40	322-2	3	Screw-HH 5/16-18 X 5/8	78	3230-22	3	Bolt-Carriage 5/16-18 X 1 Sp
41	1-303516	2	Pulley, V-Idler	79	116-9362	6	Screw-HH
				80	1-603299	6	Roller-Scalp, Anti
				81	103-4051	6	Kit, Antiscalp Roller
				82	99-2842	6	Spacer

● Assembly also includes Washer and Screw

■ Requires installation of mulch kit for proper mulching. See your Exmark dealer for details.

▲ Apply Mobil HTS grease (P/N 103-5217 1.5 oz packet) (or a food-grade anti-seize). See operator's manual for locations.

Deck Support Assembly

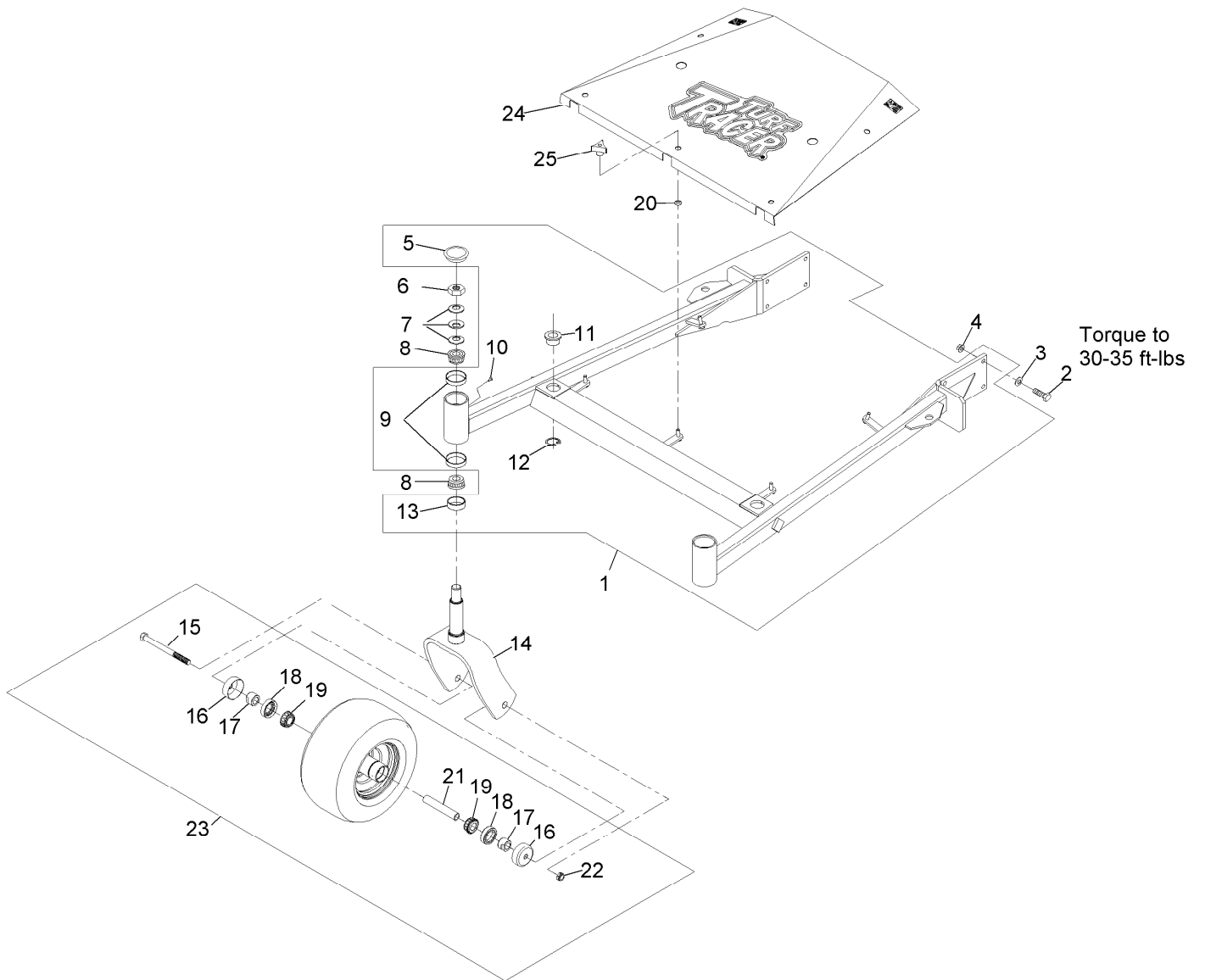

Deck Support Assembly (continued)

<i>Ref.</i>	<i>Part Number</i>	<i>Qty.</i>	<i>Description</i>	<i>Ref.</i>	<i>Part Number</i>	<i>Qty.</i>	<i>Description</i>
1	103-1896	1	Support, Deck 103-4960-01 W/Bsgs And Decals	14	103-1891-01	2	Wld, Caster Fork
2	323-7	8	Screw-HH 3/8-16 X 1 1/4	15	325-20	2	Screw-HH 1/2-13 X 6
3	98-5975	8	Washer-Spring Disc 3/8	16	103-2768	4	Guard-Seal
4	3290-357	8	Nut-Whizlock 3/8-16	17	103-3051	4	Spacer-Nut ●
5	103-4882	2	Cap-Grease	18	103-0063	4	Seal-Double Lip
6	3296-51	2	Nut-Nyloc 3/4-10	19	1-633585	4	Bearing-Cone Tapered Roller
7	1-633508	6	Washer-Spring Disc	20	1-323417	5	Washer-Belt Shield
8	1-543509	4	Cone-Bearing Tapered Roller	21	103-3157	2	Axle-Caster
9	1-543508	4	Cup-Bearing Tapered Roller	22	3296-45	2	Nut-Nyloc 1/2-13 Thin
10	1-811010	2	Plug	23	109-3524	2	Asm, Wheel And Bearings
11	1-513336	2	Bushing-Deck	24	116-2709	1	Shield, Belt (103-2273-01) W/Decal (60")
12	32120-33	2	Ring-Retaining	25	1-323385	5	Knob-3 Prong
13	1-543511	2	Seal-Grease				

● Use Pro-Lock, Nut Type (P/N 1-840022, .5ml tube) on threads.

ECS Upper Handle Controls Assembly

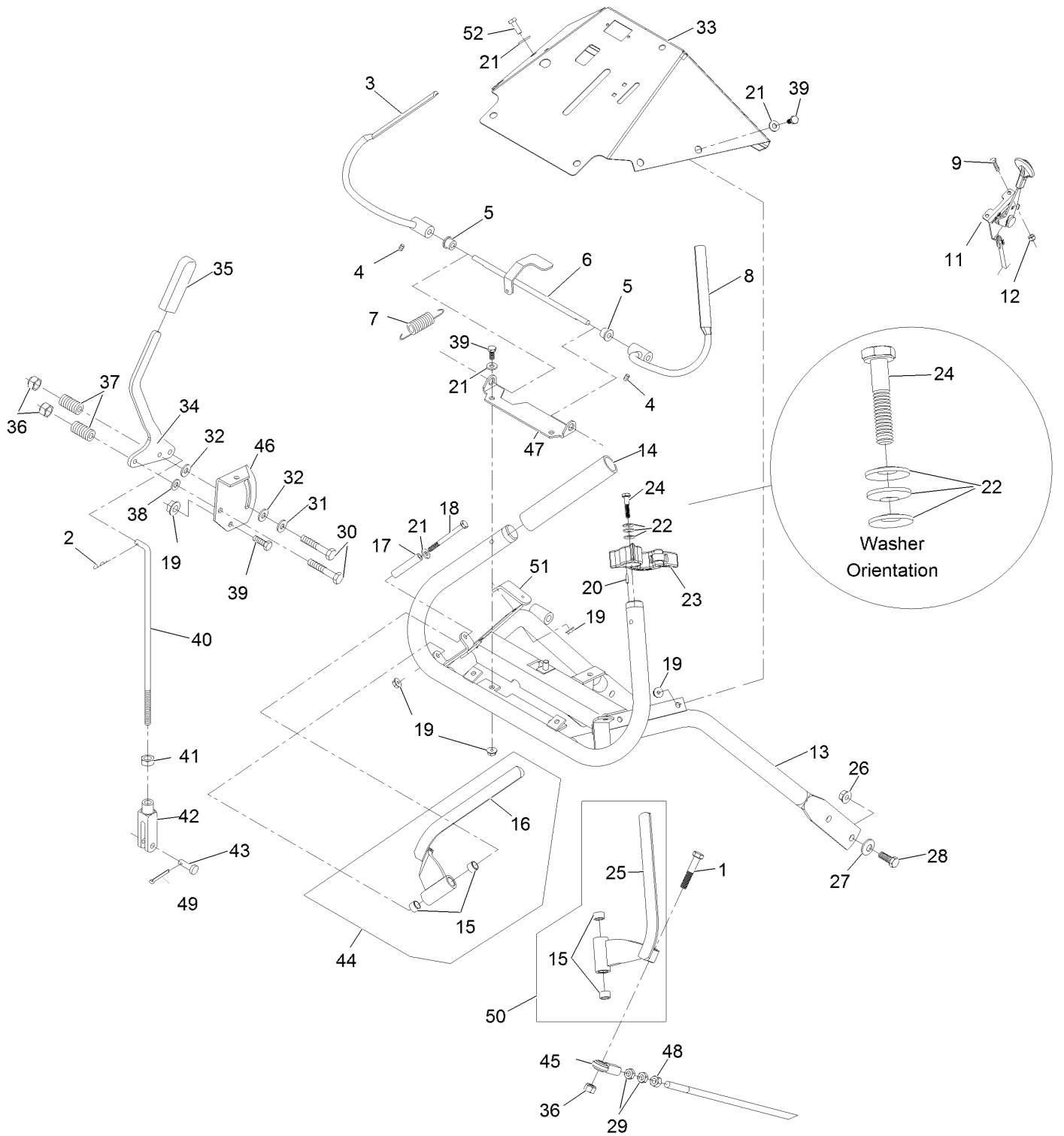

ECS Upper Handle Controls Assembly (continued)

<i>Ref.</i>	<i>Part Number</i>	<i>Qty.</i>	<i>Description</i>	<i>Ref.</i>	<i>Part Number</i>	<i>Qty.</i>	<i>Description</i>
1	322-9	2	Screw-HH 5/16-18 X 1 3/4	27	98-5975	4	Washer-Spring Disc 3/8
2	1-806003	1	Hairpin-Cotter	28	323-6	4	Screw-HH 3/8-16 X 1
3	116-4079	1	Wld, Lever, Opc (LH) ▲	29	3220-3	4	Nut-Jam 3/8-24
4	1-803322	2	Setscrew-5/16-24 X 5/16 ■	30	322-10	2	Screw-HH 5/16-18 X 2
5	1-303365	2	Bushing-Nylon	31	1-603716	1	Washer-Friction Disc
6	103-0769-03	1	Rod Weldment, Opc	32	1-323244	2	Washer-Friction
7	1-303363	1	Spring-Extension	33	126-2062	1	Console 126-1774-03 W/ Decals
8	116-4080	1	Wld, Opc Lever (RH) ▲	34	116-8632	1	Lever-Shift W/Grip
9	1-807513	2	Bolt-Carriage #10-24 X 1/2	35	103-5994	1	Grip, Steering Handle
11	109-3958	1	Control-Throttle	36	3296-29	4	Nut-Nyloc 5/16-18
12	3296-2	2	Nut-Nyloc #10-24	37	1-323245	2	Spring-Compression
13	103-1537-03	1	Handle Wld, Upper Ecs	38	3256-23	1	Washer-5/16 Sae
14	103-0815	2	Grip-Bar, Handle	39	321-3	9	Screw-HH 1/4-20 X 5/8
15	1-413152	4	Bushing-Sleeve	40	1-413225	1	Rod, Speed Control
16	116-4081	1	Lever, Drive LH	41	3220-2	1	Nut-Jam 5/16-24
17	103-0027	2	Bushing-Lever, Drive	42	1-303105	1	Yoke-Adjustable
18	321-14	2	Screw-HH 1/4-20 X 2 3/4	43	1-808280	1	Pin-Clevis 5/16 X 1 49/64
19	32128-33	12	Nut-Whizlock 1/4-20	44	103-2514	1	Asm, Drive Lever LH
20	103-0464	2	Pin-Spring 1/8 X 1/2	45	103-2463	2	Balljoint
21	3256-22	10	Washer-1/4 Sae	46	103-0503	1	Bracket, Shifter Slide
22	1-303435	6	Washer-Spring Disc 1/4	47	103-0489-03	1	Bracket, Opc Axle
23	103-1371	1	Thumb Latch Asm RH	48	3219-3	2	Nut-Hex 3/8-24
23	103-1372	1	Thumb Latch Asm LH ●	49	3272-5	1	Pin-Cotter 3/32 X 1/2
24	103-0235	2	Screw-HH 1/4-20 X 1 1/8 W/Nylon ■	50	103-2513	1	Asm, Drive Lever RH
25	116-4082	1	Lever, Drive RH	51	126-1777	1	Bracket-Relay
26	3290-357	4	Nut-Whizlock 3/8-16	52	321-4	1	Screw-HH 1/4-20 X 3/4

● Not illustrated

■ Use Pro-Lock, Nut Type (P/N 1-840022, .5ml tube) on threads.

▲ Use Pro-Lock retaining type, Part no. 1-840023 (.5cc tube) on inside of bore of OPC hub.

Engine Deck Assembly

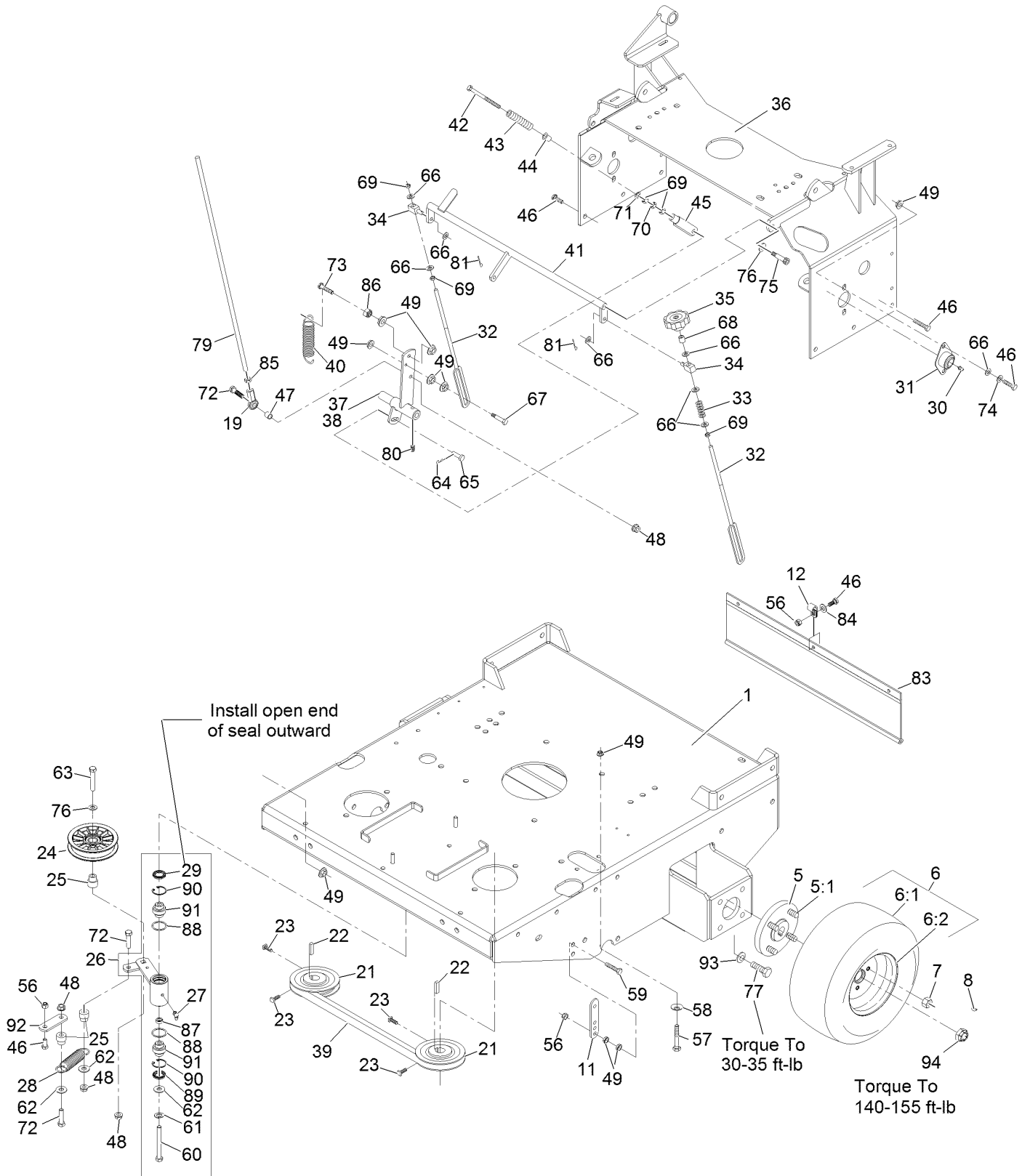

Engine Deck Assembly (continued)

<i>Ref.</i>	<i>Part Number</i>	<i>Qty.</i>	<i>Description</i>	<i>Ref.</i>	<i>Part Number</i>	<i>Qty.</i>	<i>Description</i>
1	116-6130	1	Eng Deck (116-8949-01) W/ Decals	48	3290-357	6	Nut-Whizlock 3/8-16
5	112-9049	2	Wheel Hub ASM	49	32128-20	27	Nut-Whizlock 5/16-18
5:1	1-633926	8	Stud-Wheel	56	3296-29	6	Nut-Nyloc 5/16-18
6	103-1715	2	Tire And Wheel Assy	57	322-7	4	Screw-HH 5/16-18 X 1 1/2
6:1	103-2237	2	Tire Only 18 X 8.50	58	1-303334	4	Washer-Spring Disc 5/16
6:2	103-2238	2	Wheel Only	59	1-800016	2	Bolt-HH 5/16-18 X 1 1/4 Tap
7	242-50	8	Nut-Lug 1/2-20	60	1-800805	1	Screw-HH 3/8-16 X 3-1/2 Gr8 ■
8	1-807019	2	Key-Woodruff 1 X 1/4	61	3253-5	1	Washer-Lock 3/8 Heavy
11	1-613089	2	Tab-Spring, Extension	62	3256-4	3	Washer-3/8 Std
12	1-413510	3	Clip-Loom	63	323-9	1	Screw-HH 3/8-16 X 1 3/4
19	103-1167	2	Joint-Ball End, .38X.38Fe LH	64	1-806003	2	Hairpin-Cotter
21	1-413010	2	Sheave ASM	65	1-808280	2	Pin-Clevis 5/16 X 1 49/64
22	1-807272	2	Key-5Mm X 5Mm X 25Mm	66	3256-23	11	Washer-5/16 Sae
23	120-6474	4	Screw-Set, SQH 5/16-18 X 3/4 ■	67	1-403180	2	Screw-HH 5/16-18 X 1 3/8 Special
24	109-4077	1	Pulley-Idler, Flat	68	1-603903	1	Spacer
25	1-603496	3	Bushing-Idler	69	3219-2	7	Nut-Hex 5/16-24
26	109-2578	1	Kit	70	3220-2	2	Nut-Jam 5/16-24
27	302-40	1	Zerk-90° 1/4-28	71	3256-2	2	Washer-1/4 Std
28	1-603414	1	Spring-Extension	72	323-8	4	Screw-HH 3/8-16 X 1 1/2
29	103-3506	1	Seal-Single Lip	73	116-3515	2	Screw,HH Special 5/16-18 X 1.25
30	302-19	2	Zerk-1/4-28 Str	74	1-805005	4	Washer-Lock 5/16 Heavy
31	1-633102	2	Bearing-Flanged	75	1-809056	2	Screw-Sh 5/16-18 X 1 3/8 ■
32	1-613206	2	Rod, Control Arm	76	3256-24	3	Washer-3/8 Sae
33	1-323245	1	Spring-Compression	77	323-6	8	Screw-HH 3/8-16 X 1
34	1-603676	2	Swivel-Adjustable, Short	79	103-1576	2	Rod, Drive Lever
35	103-3060	1	Knob-Tracking	80	1-803022	2	Setscrew-5/16-18 X 5/8 ■
36	116-1792-01	1	Support, Tank/Handle	81	3272-5	2	Pin-Cotter 3/32 X 1/2
37	103-1561-01	1	Arm, Control LH	83	103-2224	1	Shield, Drag
38	103-1562-01	1	Arm, Control RH ●	84	3256-3	3	Washer-5/16 Std
39	109-2584	1	Belt, Hyd Trans Drive ("a" Belt)	85	3220-16	2	Nut-Jam 3/8-24 LH
40	1-603693	2	Spring	86	3218-2	2	Nut-Jam 5/16-18
41	103-2234-01	1	Crank Weldmt	87	103-5677	1	Spacer
42	1-603737	2	Bolt-Neutral Return	88	106-7159	2	O-Ring
43	103-0265	2	Spring, Neutral Return	89	103-3505	1	Seal-Double Lip
44	1-603735	2	Bushing-Flanged	90	32120-10	2	Ring-Retaining
45	1-303105	2	Yoke-Adjustable	91	103-3504	2	Bearing-Spherical
46	322-3	14	Screw-HH 5/16-18 X 3/4	92	1-633068	1	Arm-Lift, Deck
47	103-2421	2	Tube, Pump Link Spacer	93	98-5975	8	Washer-Spring Disc 3/8
				94	116-2839	2	Nut-Lock

● Not illustrated

■ Use Pro-Lock, Nut Type (P/N 1-840022, .5ml tube) on threads.

Park Brake and Engine Assembly

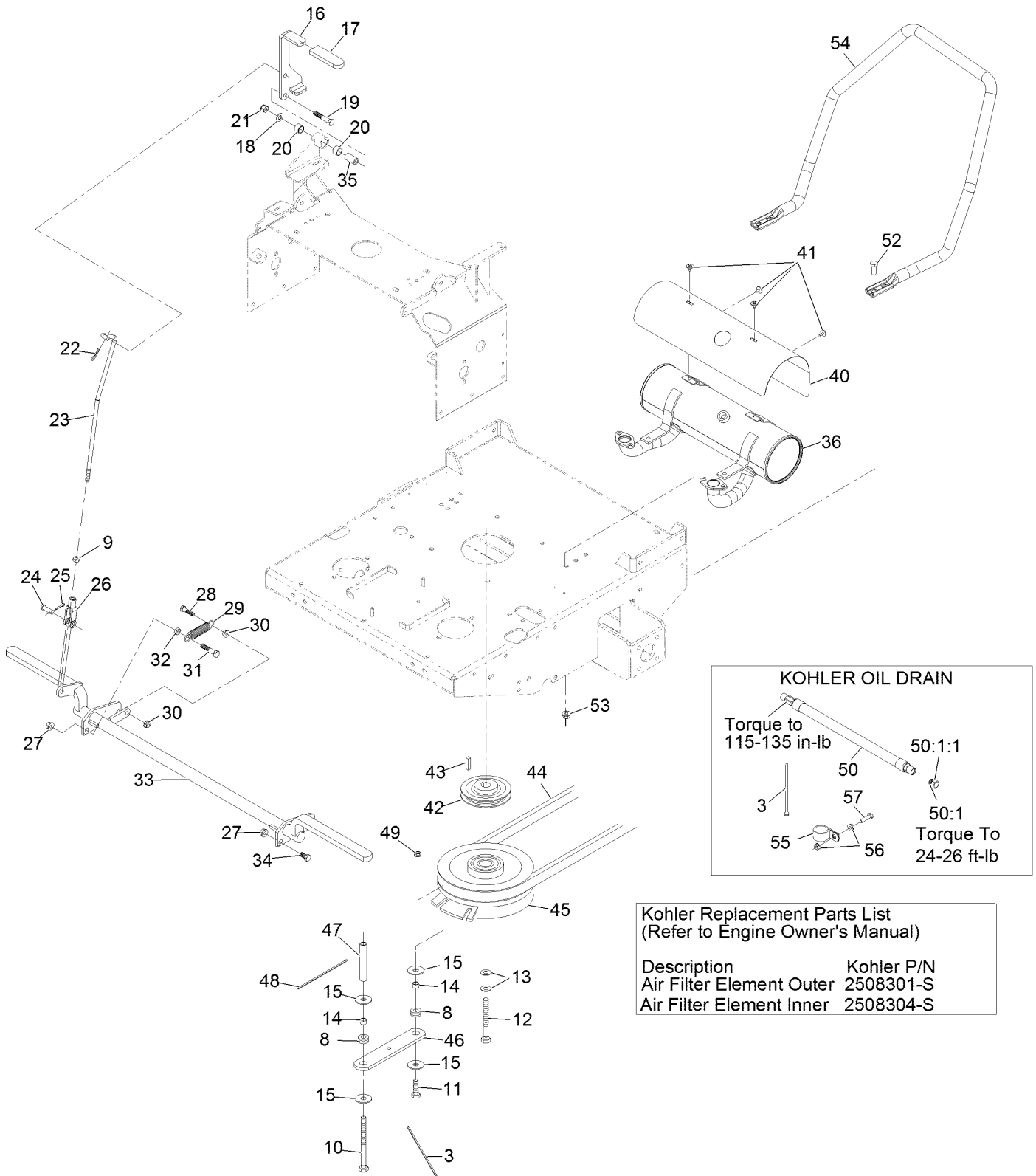

KOHLER OIL DRAIN

Torque to 115-135 in-lb

50:1:1

50:1

Torque To 24-26 ft-lb

Kohler Replacement Parts List
(Refer to Engine Owner's Manual)

Description	Kohler P/N
Air Filter Element Outer	2508301-S
Air Filter Element Inner	2508304-S

Park Brake and Engine Assembly (continued)

<i>Ref.</i>	<i>Part Number</i>	<i>Qty.</i>	<i>Description</i>	<i>Ref.</i>	<i>Part Number</i>	<i>Qty.</i>	<i>Description</i>
3	1-303335	2	Tie-Cable 7 15/16 (Large)	30	32128-20	6	Nut-Whizlock 5/16-18
8	1-633630	2	Grommet	31	323-9	1	Screw-HH 3/8-16 X 1 3/4
9	3220-3	1	Nut-Jam 3/8-24	32	3218-3	1	Nut-Jam 3/8-16
10	322-38	1	Screw-HH 5/16-18 X 4 1/2	33	116-9159	1	Brake Weldmt
11	322-6	1	Screw-HH 5/16-18 X 1 1/4	34	323-4	3	Screw-HH 3/8-16 X 3/4
12	3212-10	1	Screw-HH 7/16-20 X 2 1/2 ▲	35	1-413344	1	Bushing-Pivot
13	1-603610	2	Washer-Spring Disc 7/16	36	116-8653	1	Muffler
14	1-633545	2	Spacer	40	116-8654	1	Shield-Muffler
15	1-613235	4	Washer	41	116-1103	4	Screw-HH, Thread Forming
16	109-4544	1	Lever, Park Brake (109-4543-03) W/Decal And Grip	42	1-653035	1	Pulley ●
17	1-303020	1	Grip-Lever	43	1-807259	1	Key-Machine 1/4 X 1/4 X 1
18	3256-24	1	Washer-3/8 Sae	44	1-603306	1	Belt, Deck Drive (60")
19	322-10	1	Screw-HH 5/16-18 X 2	45	103-0662	1	Clutch ASM
20	1-413347	2	Sleeve-Bushing	46	1-633543-03	1	Strap-Clutch, Brake
21	3296-39	1	Nut-Nyloc 3/8-16	47	1-323195-03	1	Standoff, Clutch
22	1-806003	1	Hairpin-Cotter	48	1-303287	1	Tie-Cable 5 1/2 (Small)
23	109-4078	1	Linkage, Park Brake	49	32128-20	1	Nut-Whizlock 5/16-18
24	1-808285	1	Pin-Clevis 3/8 X 1 1/8	50	116-5316	1	Oil Drain Hose ASM ■
25	3272-10	1	Pin-Cotter 1/8 X 3/4	50:1	353-508	1	Plug-W/O-Ring
26	1-633131	1	Yoke-Linkage, Brake	50:1:1	237-42	1	O-Ring
27	3290-357	4	Nut-Whizlock 3/8-16	52	323-6	4	Screw-HH 3/8-16 X 1
28	116-3515	1	Screw,HH Special 5/16-18 X 1.25	53	104-8301	4	Nut-Nyloc 3/8-16 Flg
29	1-323161	1	Spring	54	116-8575-03	1	Guard-Air Cleaner
				55	1-643312	1	Clip-Loom
				56	32128-33	2	Nut-Whizlock 1/4-20
				57	321-6	1	Screw-HH 1/4-20 X 1

● Install sheave with long end of hub up.

■ Use a Teflon Pipe Sealant or equivalent on threads.

▲ Use Pro-Lock, Nut Type (P/N 1-840022, .5ml tube) on threads.

Hydraulic Assembly

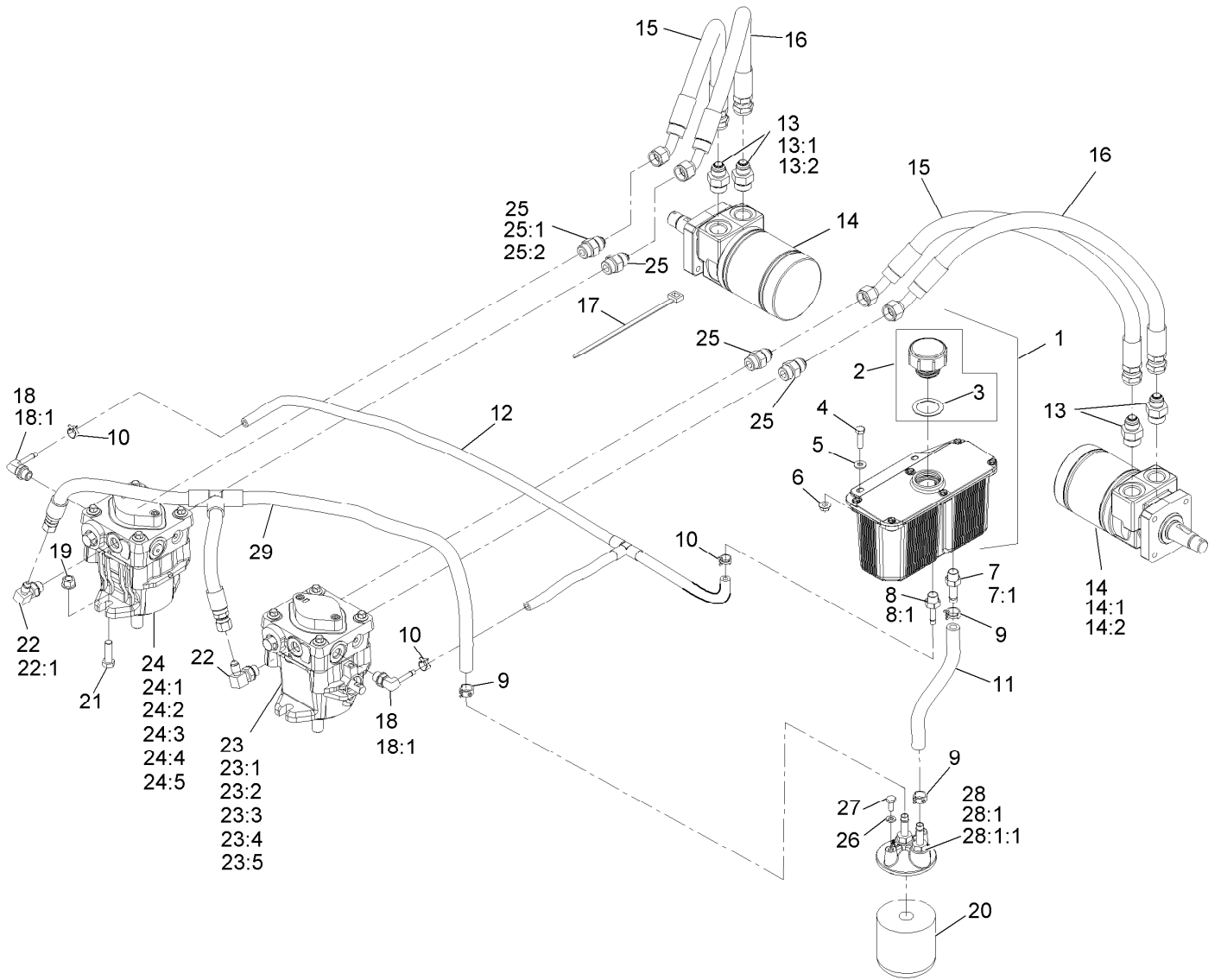

Hydraulic Assembly (continued)

<i>Ref.</i>	<i>Part Number</i>	<i>Qty.</i>	<i>Description</i>	<i>Ref.</i>	<i>Part Number</i>	<i>Qty.</i>	<i>Description</i>
1	103-1947	1	HYD Reservoir ASM	22	103-1802	2	Fitting-HYD, 90 DEG
2	103-7615	1	Asm, Cap W/Gasket	22:1	1-603921	1	O-Ring
3	103-1949	1	Gasket-Cap	23	116-2495	1	Pump, Hydro RH
4	321-6	2	Screw-HH	23:1	103-2664	1	Input Shaft Kit
5	3256-22	2	Washer-Flat	23:2	94-6922	1	Bearing-Thrust
6	32128-33	2	Nut-HF	23:3	103-2666	1	Cylinder Block Kit
7	103-1912	1	Adapter-Straight	23:4	105-6184	1	Seal Overhaul Kit
7:1	1-603921	1	O-Ring	23:5	126-2479	1	Kit, Hydro Pump
8	103-1801	1	Adapter-Straight	23:5:1		1	Kit-10Cc Cylinder Block ●■
8:1	1-603921	1	O-Ring	23:5:2		1	Plate, Valve ●■
9	103-1988	3	Clamp-Hose	23:5:3		1	Gasket, Housing ●■
10	103-1716	3	Clamp-Hose	24	116-2494	1	Pump, Hydro LH
11	109-1010	1	Hose, Hydraulic	24:1	103-2664	1	Input Shaft Kit
12	126-2053	1	Asm, Case Drain Hose	24:2	94-6922	1	Bearing-Thrust
13	1-603991	4	Fitting-Straight	24:3	103-2666	1	Cylinder Block Kit
13:1	1-603919	1	O-Ring	24:4	105-6184	1	Seal Overhaul Kit
13:2	1-603992	1	O-Ring	24:5	126-2479	1	Kit, Hydro Pump
14	1-603718	2	HYD Motor ASM	24:5:1		1	Kit-10Cc Cylinder Block ●■
14:1	1-000119	1	Seal Kit	24:5:2		1	Plate, Valve ●■
14:2	1-000138	1	Bearing And Seal Kit	24:5:3		1	Gasket, Housing ●■
15	116-8646	2	Hose, Hydro	25	1-603990	4	Fitting-Straight
16	116-8647	2	Hose, Hydro	25:1	1-603920	1	O-Ring
17	1-303335	1	Tie-Plastic	25:2	1-603992	1	O-Ring
18	103-1799	2	Elbow-90 DEG	26	1-805004	2	Washer-Lock
18:1	1-603921	1	O-Ring	27	321-3	2	Screw-HH
19	32128-43	4	Nut-Flange	28	103-2889	1	Filter Head ASM
20	109-4180	1	Element, Oil Filter	28:1	103-1912	2	Adapter-Straight
20	1-523541	1	Element, Oil Filter (Winter) ▲	28:1:1	1-603921	1	O-Ring
21	323-7	4	Screw-HH	29	103-4608	1	Asm, Charge Hose

● Not illustrated

▲ Use only for operation below 32°F (0°C).

■ Not serviced separately

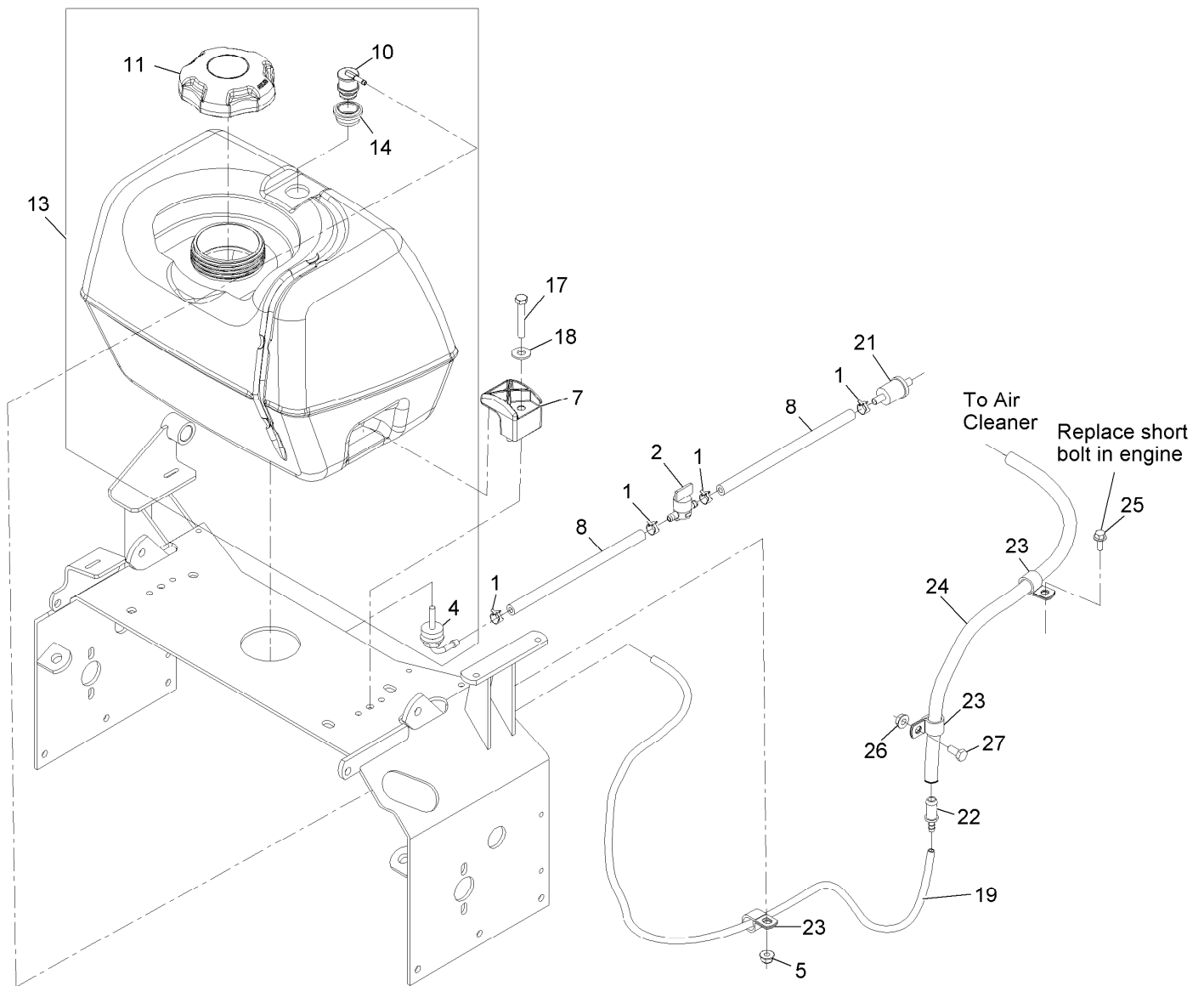

Fuel Tank Assembly

Ref.	Part Number	Qty.	Description
1	2412-98	4	Clamp-Hose
2	1-603770	1	Valve-Fuel
4	103-2605	1	Fitting-Fuel Bulkhead W/Strainer ▲
5	104-8300	2	Nut-Nyloc 5/16-18 Flg
7	107-4543	2	Clamp
8	110-1876	1	Hose-Fuel
10	119-3547	1	Valve-Vent, Fuel
11	115-4465	1	Cap-Fuel, Ratcheting
13	126-1525	1	ASM, Fuel Tank
14	114-0284	1	Grommet

Ref.	Part Number	Qty.	Description
17	322-10	2	Screw-HH 5/16-18 X 2
18	3256-3	2	Washer-5/16 Std
19	126-1679	1	Hose-Fuel
21	Pn 24 050 13	1	Filter-Fuel ■●
22	98-2952	1	Fitting-Straight
23	1-633396	3	Clip-Loom 5/8
24	119-8562	1	Hose-Fuel
25	33103-016	1	Screw-HH Flg M6-1 X 16Mm
26	32128-33	1	Nut-Whizlock 1/4-20
27	321-4	1	Screw-HH 1/4-20 X 3/4

● Not serviced separately

▲ Use Pro-Lock, Nut Type (P/N 1-840022, .5ml tube) on threads.

■ Obtain parts from www.kohlerplus.com

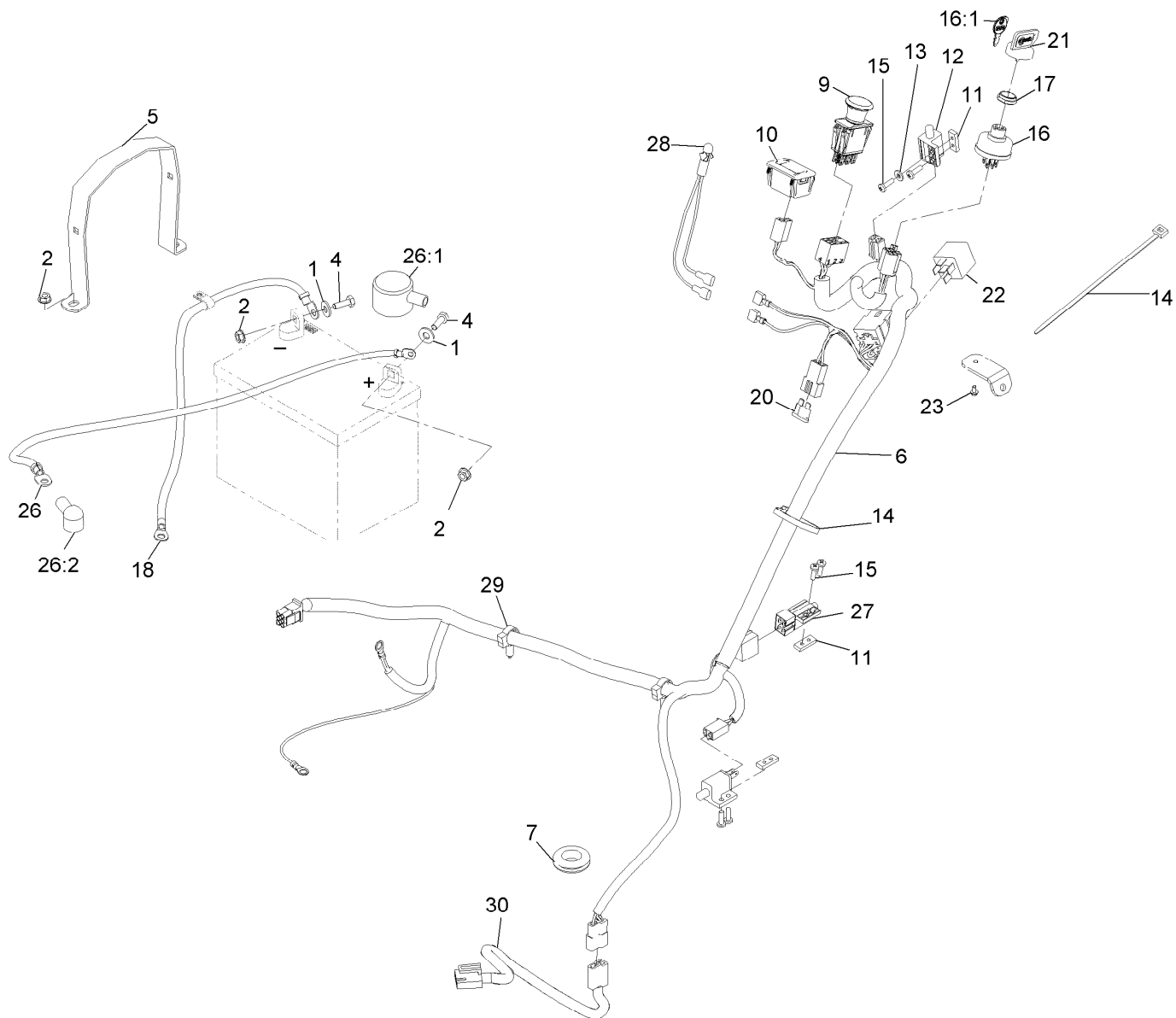

Electrical Assembly

Ref.	Part Number	Qty.	Description	Ref.	Part Number	Qty.	Description
1	3256-2	2	Washer-1/4 Std	16:1	1-603511	1	Key-Ignition
2	32128-33	4	Nut-Whizlock 1/4-20	17	103-0498	1	Nut-Ignition
4	321-4	2	Screw-HH 1/4-20 X 3/4	18	1-543767	1	Wire-Ground
5	1-603814-03	1	Strap, Battery Holddown	20	1-816001	1	Fuse-Blade Type, 20 Amp
6	126-2016	1	Harness, Wiring ●	21	103-2106	1	Key-Exmark Logo
7	1-543286	1	Grommet	22	1-643275	1	Relay-12Vdc 40 Amp
9	103-5221	1	Switch-PTO	23	104-2065	1	Screw-HWH #10-24 X 3/8
10	120-2244	1	Hourmeter	26	109-7621	1	Positive Battery Cable ASM
11	1-633181	3	Plate-Tapped	26:1	109-2407	1	Insulator-Battery
12	1-513051	2	Switch-N.O.	26:2	1-543393	1	Insulator-Solenoid
13	3256-14	1	Washer-#10 Std	27	1-633110	1	Switch
14	1-303335	2	Tie-Cable 7 15/16 (Large)	28	1-643267	1	Indicator-Red Led
15	3290-500	6	Screw-PPH #10-24 X 5/8	29	32180-047	1	Clip-Harness
16	103-0206	1	Switch-Ignition W/Keys	30	126-0624	1	Harness-Clutch Pigtail ●

● Use dielectric grease on all unsealed connectors and terminals only. Do not apply in sealed connectors.

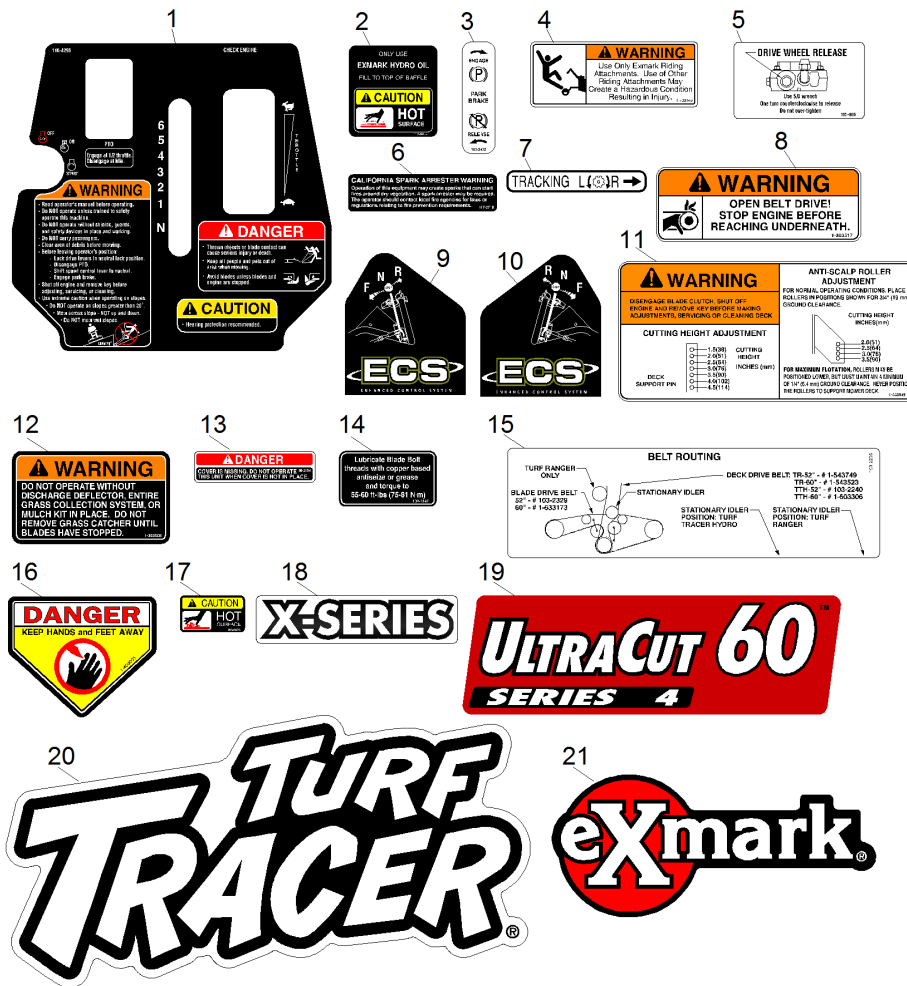

Decals

Ref.	Part Number	Qty.	Description
1	116-4296	1	Decal, Console Ecs
2	116-0404	1	Decal-Hydraulic Tank
3	103-2432	1	Decal, Brake Lever
4	1-403143	1	Decal, Sulky Warning
5	103-4935	1	Decal, Drive Wheel Release
6	117-2718	1	Decal-Arrester, Spark
7	1-413214	1	Decal, Tracking
8	1-303517	1	Decal,Belt Drive
9	103-2242	1	Decal, Ecs Instruction LH
10	103-2243	1	Decal, Ecs Instruction RH
11	1-553049	1	Decal, Mower Deck
12	1-303508	1	Decal-Warning, Discharge
13	98-5954	3	Decal-Cover, Missing
14	109-3148	1	Decal, Bolt Torque
15	103-2239	1	Decal, Belt Routing
16	1-403005	2	Decal-Danger
17	103-2076	2	Decal-Caution
18	116-3883	2	Decal-X-Series
19	116-0025	1	Decal,Ultracut 60 Series 4
20	103-3013	1	Decal, Turf Tracer
21	103-2882	1	Decal, Exmark Logo
99	103-5828	1	Kit, Decal Complete •

• Not illustrated

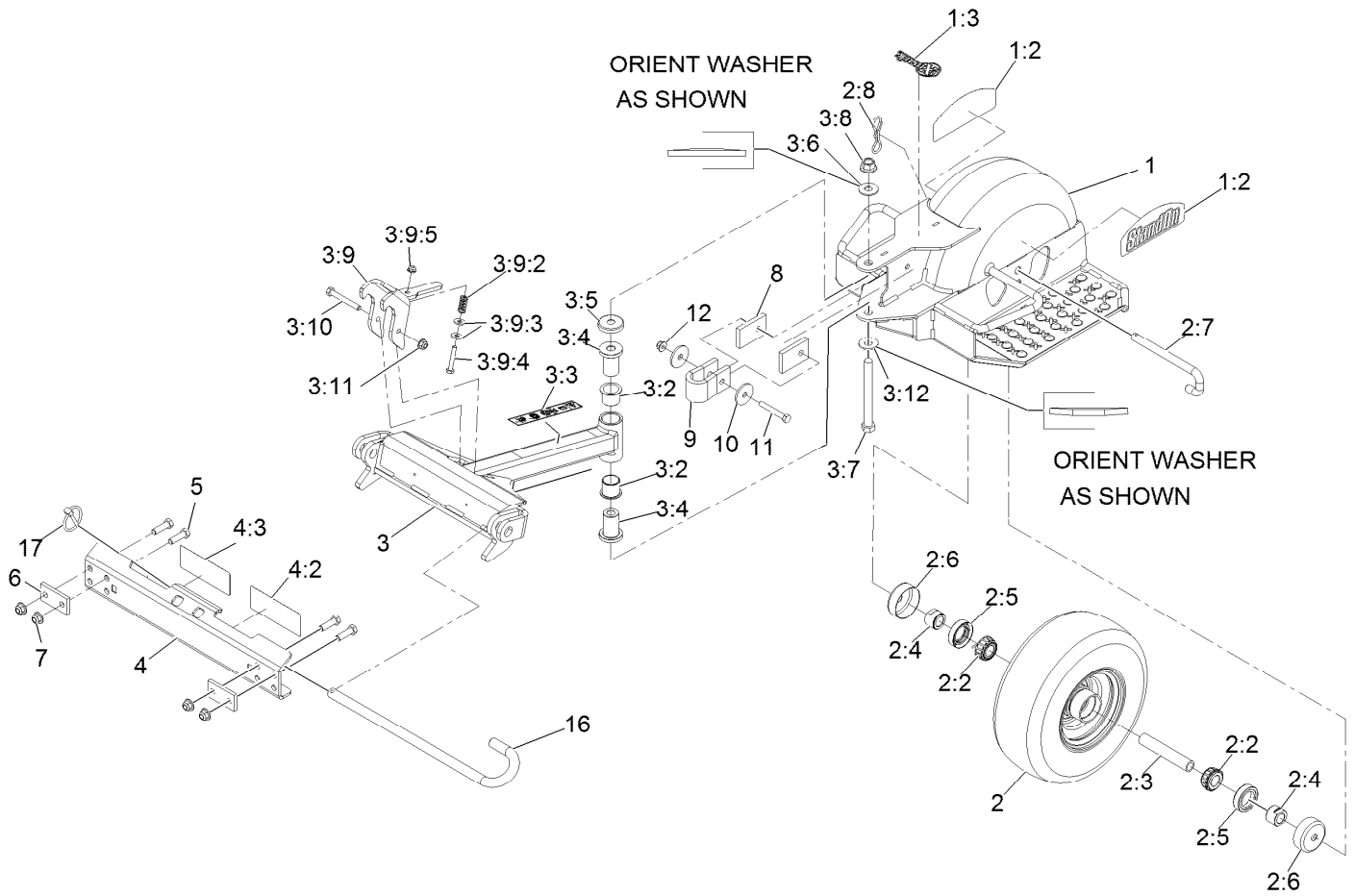

StandOn Assembly

Ref.	Part Number	Qty.	Description
1	126-1952	1	ASM-Sulky Frame W/ Decals
1:2	109-1117	2	Decal
1:3	103-8845	1	Decal-Exmark
2	116-7228	1	ASM, Wheel And Bearings
2:2	1-633585	2	Bearing-Cone Tapered Roller
2:3	103-3157	1	Axle-Caster
2:4	103-3051	2	Spacer-Nut
2:5	103-0063	2	Seal-Double Lip
2:6	103-2768	2	Guard-Seal
2:7	116-6017	1	Pin, Caster
2:8	116-6392	1	Pin-Cotter, Locking
3	126-1958	1	ASM, Draw Bar
3:2	126-1963	2	Bushing-Pivot
3:3	126-1411	1	Decal-Sulky Hazard
3:4	126-1964	2	Spacer, Pivot
3:5	116-6313	1	Cover, Dust
3:6	116-8429	1	Washer-Belleville
3:7	325-19	1	Screw-HH 1/2-13 X 5
3:8	99-5107	1	Nut-Lock 1/2-13

Ref.	Part Number	Qty.	Description
3:9	126-2125	1	Transport Latch ASM
3:9:2	116-6523	1	Spring, Compression
3:9:3	3256-2	2	Washer-1/4 Std
3:9:4	321-37	1	Screw-HH
3:9:5	104-7201	1	Nut-Nyloc 1/4-20 Flg
3:10	322-12	1	Screw-HH 5/16-18 X 2 1/2
3:11	104-8300	1	Nut-Nyloc 5/16-18 Flg
3:12	1-513435	1	Washer-Spring Disc 1/2
4	126-1955	1	ASM, Mount Plate
4:2	116-8225	1	Decal-Belt Drive Warning
4:3	126-1400	1	Decal-Sulky Warning
5	323-7	4	Screw-HH 3/8-16 X 1 1/4
6	103-6663	2	Plate, Back-Up
7	104-8301	4	Nut-Nyloc 3/8-16 Flg
8	103-6654	2	Pad, Stop
9	103-6652	1	Stop, Rotation
10	1-213069	2	Washer
11	322-11	1	Screw-HH 5/16-18 X 2 1/4
12	104-8300	1	Nut-Nyloc 5/16-18 Flg
16	116-6302	1	Pin, Pivot
17	92-1298	1	Pin-Lynch

Notes:

Notes:

Notes:

EXMARK® MAINTENANCE

MAXIMIZE THE PERFORMANCE OF YOUR EXMARK.

4-CYCLE PREMIUM ENGINE OIL

Part No. 116-3373

Both SAE 30 and SAE 10W-30 in one bottle.

Contains increased levels of zinc and phosphorus for better lubricity.

No Viscosity Index Improvers that tend to shear down in high heat.

Synthetic formulation.

Gas & Diesel compatible.

Anti-corrosion additives.

API 'SL' and JASO rated with wet clutch compatibility for other machines.

PREMIUM HYDRO OIL

Part No. 109-9828

Commercial quality for tough, high-heat conditions.

Designed specifically for zero-turn mower hydraulic systems.

Superior shear resistance under heavy loads.

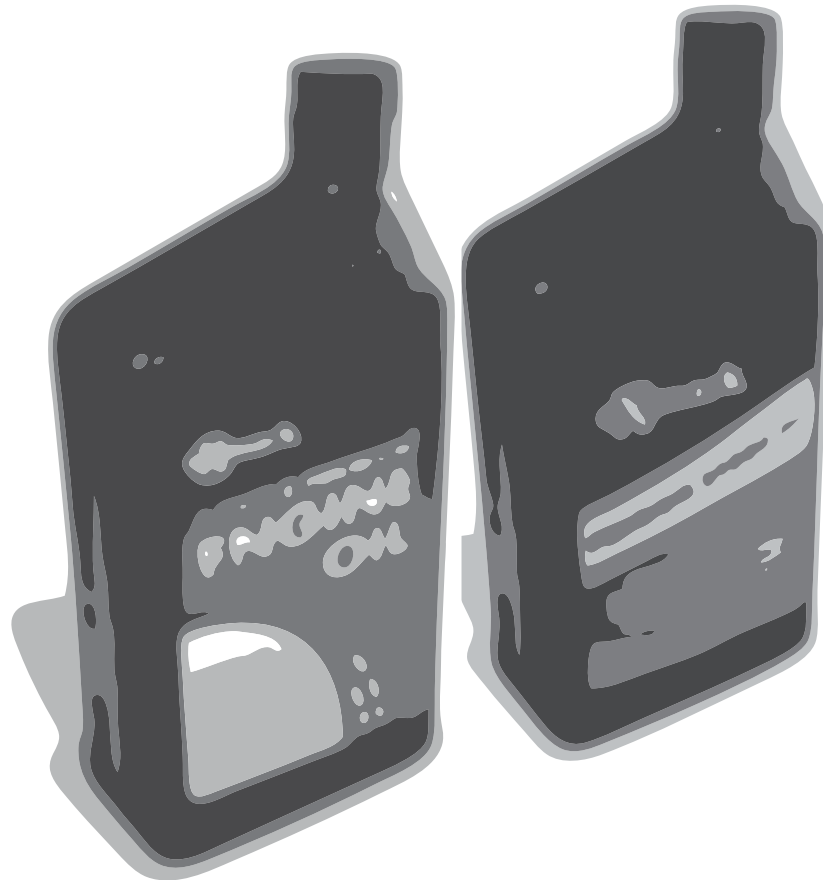

Available from your local Exmark dealer. Find your closest dealer at exmark.com

EXMARK ACCESSORIES AND OPTIONS*

MID-MOUNT RIDING ACCESSORIES AND OPTIONS

CUSTOM RIDE SEAT SUSPENSION SYSTEM	OPERATOR CONTROLLED DISCHARGE
FULL SUSPENSION SEAT	SUN SHADE
DECK LIFT ASSIST KIT	TRASH CONTAINER
HITCH KIT	TURF STRIPER
LIGHT KIT	ULTRA VAC COLLECTION SYSTEM
12V POWER PORT	ULTRA VAC QUICK DISPOSAL SYSTEM
MICRO-MULCH SYSTEM	

OUT-FRONT RIDING ACCESSORIES AND OPTIONS

CUSTOM RIDE SEAT SUSPENSION SYSTEM	SNOW BLADE
DUAL-TAIL WHEEL	SNOWBLOWER
FLOOR PAN EXTENDER	SUN SHADE
HITCH KIT	TRASH CONTAINER
LIGHT KIT	ULTRA VAC COLLECTION SYSTEM
MICRO-MULCH SYSTEM	ULTRA VAC QUICK DISPOSAL SYSTEM
ROLL OVER PROTECTION SYSTEM (ROPS)	WEATHER CAB

WALK-BEHIND ACCESSORIES AND OPTIONS

GRASS CATCHER	TURF STRIPER
MICRO-MULCH SYSTEM	STANDON

*Some accessories and options not available for some models.

Place Model No. and Serial No.
Label Here (Included in the Literature
Pack) or Fill in Below

Model No. _____

Serial No. _____

Date Purchased _____

Engine Model No. and Spec. No. _____

Engine Serial No. (E/No) _____

© 2014 Exmark Mfg. Co., Inc.
Industrial Park Box 808
Beatrice, NE 68310
All Rights Reserved

Part No. 4501-708 Rev. B
(402)223-6300
Fax (402) 223-5489
Printed in the USA.

