

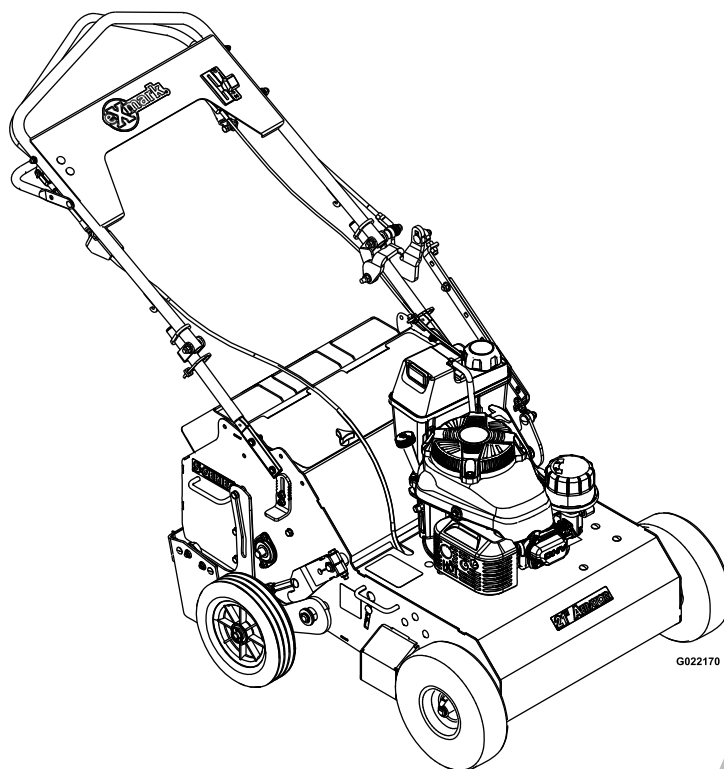

21 INCH WALK-BEHIND AERATOR

Model No. ARS180KA21—Serial No. 31400000 and Up

Picture below may not reflect actual product.



Parts Manual

Part No. 4501-688 Rev. A

Ordering Replacement Parts

To order replacement parts, please supply the part number, the quantity, and the description of each part desired.

Understanding Reference Numbers

Each identified part in an illustration has a reference number. The reference number for a part also appears in the parts list, along with other information about the part.

This catalog uses two special reference number formats, one to indicate parts in a service assembly and another to indicate the quantity of a given part in an illustration.

Service Assembly Reference Numbers

Parts in service assemblies have reference numbers in the form a:b. The a represents the reference number of the entire service assembly and the b represents a sequential number unique to each part within the service assembly.

For example, a wheel assembly might be identified by reference number 6, the tire by 6:1, the valve by 6:2, and the wheel by 6:3. When you order the assembly identified by reference number 6, you receive all parts identified by reference numbers 6:1, 6:2, and 6:3. However, you may also order any part individually. Reference numbers of this type appear in illustration and in parts lists.

Reference Numbers Indicating Quantity

In an illustration, if a reference number indicates more than one part, the reference number has the form nX y. The n represents the quantity of the part, the X is the multiplication symbol, and the y represents the reference number.

For example, in an illustration, the reference number 2X 37 means that two of the parts identified by reference number 37 are indicated.

List of Abbreviations

AR: as required	HJ: hex jam	PRH: phillips round head
ASM: assembly	HLH: hex lag head	PTH: phillips truss head
BBC: blade brake control	HOC: height-of-cut	PTO: power-take-off
BHTF: button head thread forming	HSBH: hex socket button head	RH: right hand
CARR: carriage	HSFH: hex socket flat head	ROPS: roll-over protection system
CCW: counter clockwise	HSH: hex socket head	RRB: rear roller brush
CW: clockwise	HWH: hex washer head	SFH: slotted fillister head
DEG: degrees	HWHTF: hex washer head thread forming	SHH: slotted hex head
DPA: Dual Point Adjustment	HYD: hydraulic	SHWH: slotted hex washer head
ECM: electronic control module	LH: left hand	SPH: slotted pan head
EXT: external	LP: Liquefied Petroleum Gas	SQH: square head
FH: flat head	LPG: Liquefied Petroleum Gas	SRH: slotted round head
GA: gauge	NI: nylon insert	STD: standard
HD: heavy-duty	NPTF: national pipe thread fine	TAP: self tapping
HF: hex flange	PFH: phillips flat head	TTH: torx truss head
HH: hex head	PPH: phillips pan head	
HHF: hex head flange	PPHTF: phillips pan head thread forming	
HHFTF: hex head flange thread forming		

Touch Up Paint

Exmark black touch up spray paint – gloss black.

Exmark red touch up paint (spray paint – P/N 1-850337 - .6 oz liquid bottle – P/N 103-9140).



If your Exmark dealer does not have the Exmark part in stock, Exmark will get the parts to the dealer the next business day or the part will be FREE Guaranteed!! (Some restrictions apply. See your participating Exmark Dealer for details.)

Contents

- Frame Assembly..... 4
- Frame Assembly W/Decals 5
- Engine and Fuel Tank Assembly 6
- Drive Assembly..... 7
- Handle Assembly 8
- Height Linkage Assembly 9
- Tine Assembly 10

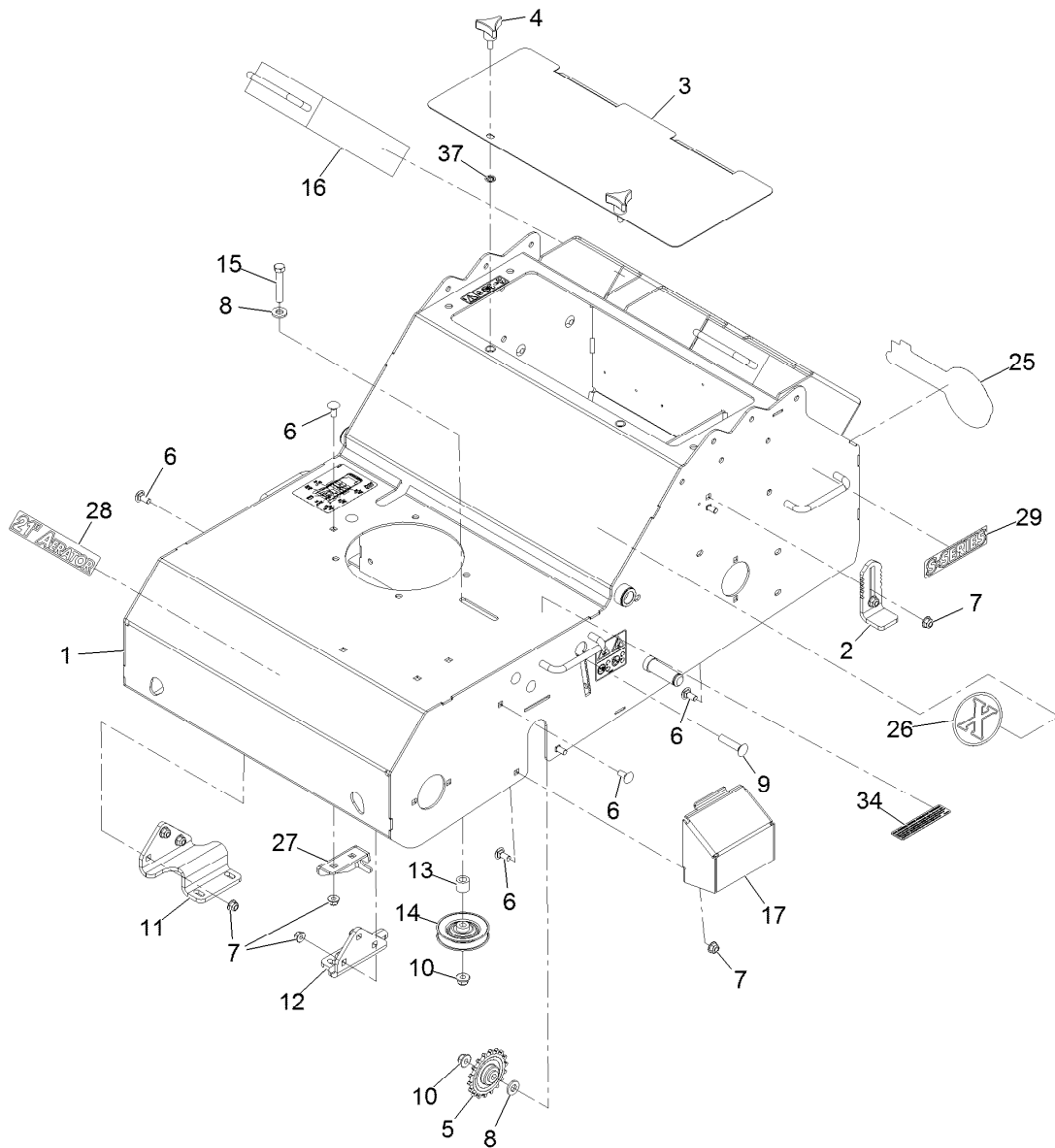

Frame Assembly

Ref.	Part Number	Qty.	Description	Ref.	Part Number	Qty.	Description
1	116-9867	1	Frame-Service ASM	14	62-4530	1	Pulley
2	116-9886	2	Stop-Depth	15	323-11	1	Screw-HH 3/8-16 X 2 1/4
3	126-0974-01	1	Cover-Access	16	121-6080	2	Weight-Aerator
4	109-3351	2	Knob-5/16X3/4 3-Prong	17	121-1981-01	2	Cover-Transaxle
5	121-4915	2	Sprocket-Idler	25	103-3999	1	Decal, Exmark Logo (Console)
6	3230-1	16	Bolt-Carriage 5/16-18 X 3/4	26	116-7035	1	Decal-Exmark X-Logo
7	104-8300	16	Nut-Nyloc 5/16-18 Flg	27	121-6056	1	Bracket-Mounting, Cable
8	87-7480	3	Washer	28	116-6953	1	Decal-Aerator 21
9	3231-29	2	Bolt-Carriage 3/8-16 X 1 3/4	29	116-3884	2	Decal-S-Series
10	104-8301	3	Nut-Nyloc 3/8-16 Flg	34	117-2718	1	Decal-Spark Arrester
11	121-4948-03	1	Bracket-Mount Axle, RH	37	117-2749	2	Nut-Push
12	121-4949-03	1	Bracket-Mount Axle, LH				
13	121-6087	1	Bushing-Idler				

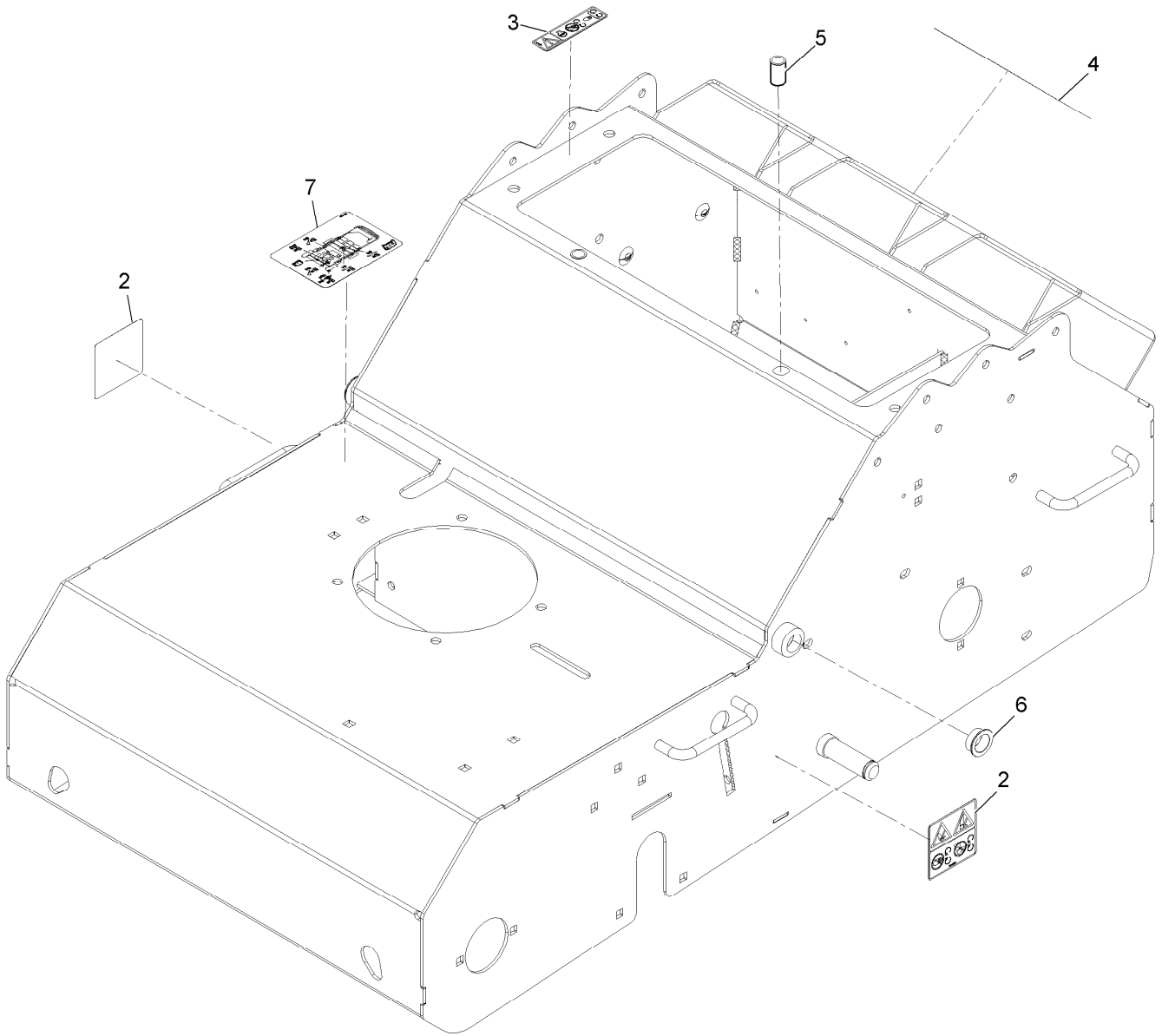

Frame Assembly W/Decals

<i>Ref.</i>	<i>Part Number</i>	<i>Qty.</i>	<i>Description</i>
2	121-6150	2	Decal-Warning
3	119-0217	1	Decal-Danger
4	126-0651	1	Decal-Warning Aerator 21
5	32148-7	2	Nut-Insert
6	108519	2	Bushing-Bronze
7	126-1209	1	Decal-Service Aid 21 Aerator

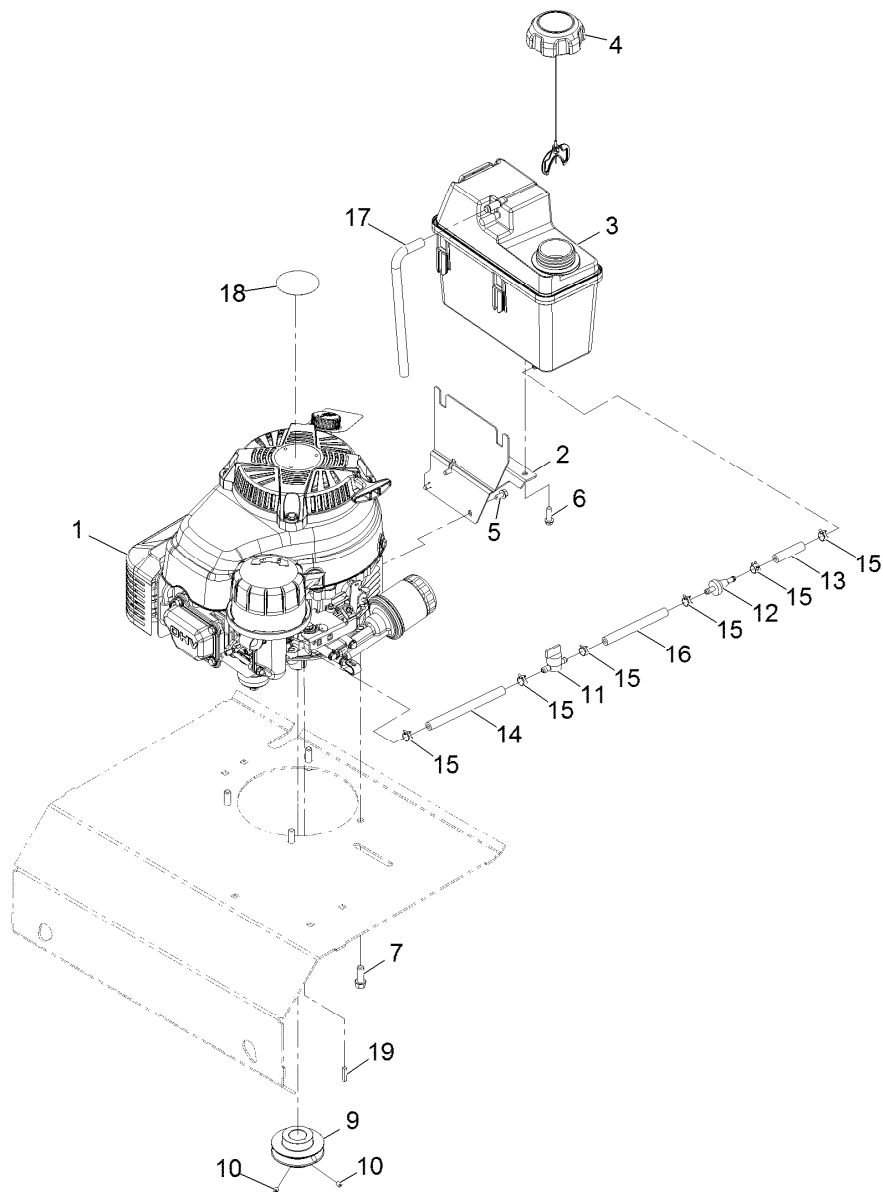

Engine and Fuel Tank Assembly

Ref.	Part Number	Qty.	Description	Ref.	Part Number	Qty.	Description
1		1	Engine-Kawasaki, Fj180V-Bm02-M ●■	10	3245-35	2	Screw-Set HSH 1/4-28 X 1/4 ▲
2	115-0954-03	1	Tank Mount ASM	11	1-603770	1	Valve-Fuel
3	125-5066	1	Tank ASM	12	71-9280	1	Filter-Fuel
4	109-6776	1	Cap-Ratchet, Tethered	13	99-9415	1	Hose-Fuel
5	104-2628	3	Screw-HWH M6-1 X 12Mm Tf	14	109-0300	1	Hose-Fuel
6	46-8091	2	Screw-HWH 1/4-10 X .82 Plastite	15	2412-98	6	Clamp-Hose
7	95-1726	4	Screw-HWH 3/8-16 X 1 Taptite	16	109-0650	1	Hose-Fuel
9	126-0839	1	Pulley-Driver	17	115-0962	1	Hose-Vent, Canister
				18	109-6528	1	Decal, Recoil
				19	6366	1	Key-3/16 X 3/16 X 7/8

● Not serviced separately

▲ Use Pro-Lock, Nut Type (P/N 1-840022, .5ml tube) on threads.

■ Obtain parts from www.kawpowerpc.com

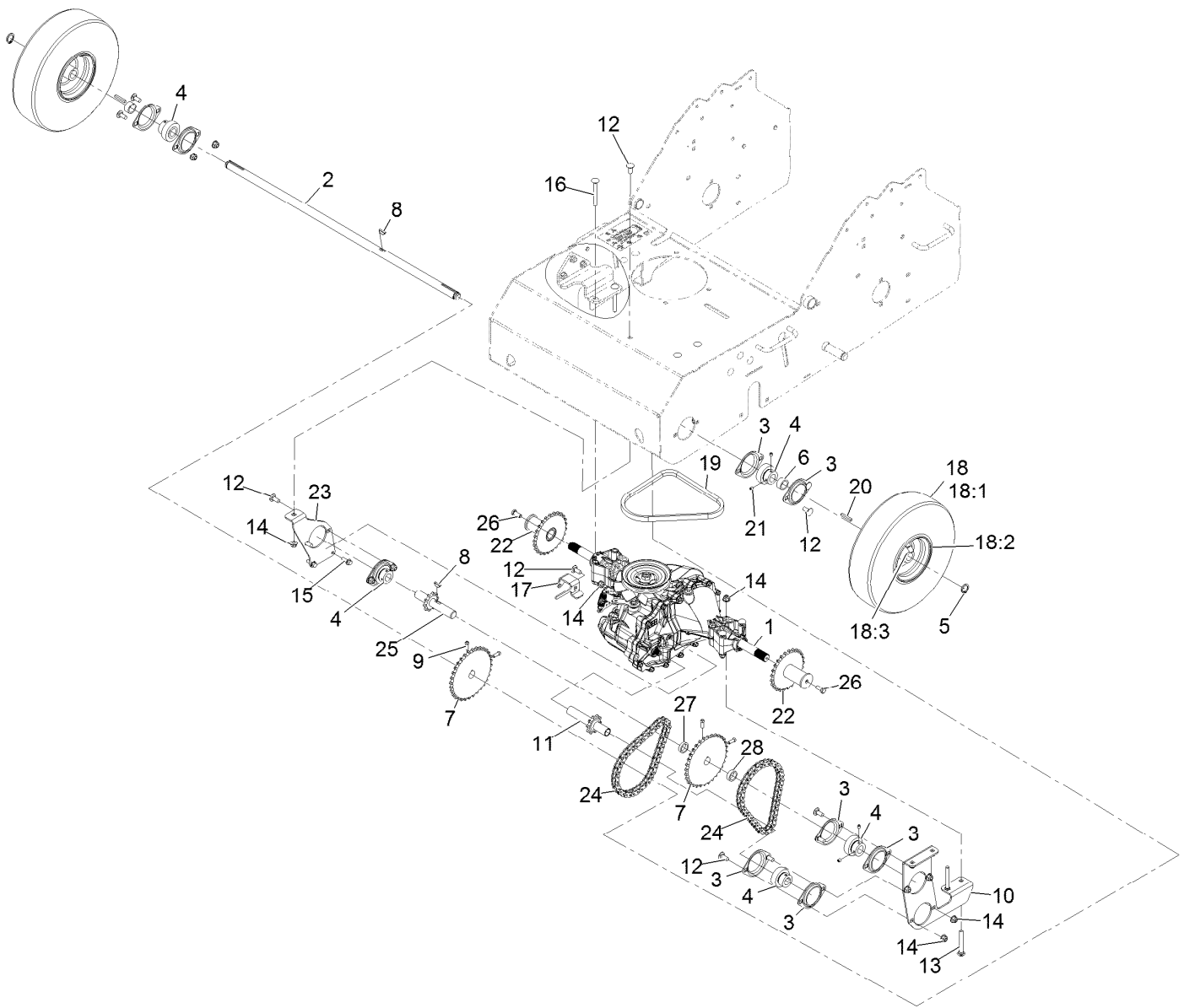

Drive Assembly

Ref.	Part Number	Qty.	Description	Ref.	Part Number	Qty.	Description
1	121-4899	1	Transaxle ASM	16	3230-9	4	Bolt-Carriage 5/16-18 X 2 3/4
2	121-4927	1	Shaft-Wheel	17	121-6067	1	Angle-Control
3	105-9714	10	Flange-Bearing	18	120-3550	2	Wheel ASM
4	120-9350	5	Bearing-Lock, Collar	18:1	121-6081	1	Tire
5	32120-93	2	Ring-Retaining	18:2	121-6082	1	Wheel-Rim
6	121-4931	2	Spacer-Wheel	18:3	5108	1	Valve
7	121-4934	2	Sprocket	19	121-1999	1	Belt-Drive
8	3257-5	2	Key-Woodruff #9 3/4 X 3/16	20	92-0049	2	Key-Machine 3/16 X 3/16 X 1 1/4
9	3241-5	4	Setscrew-SQH 1/4-20 X 5/8	21	3245-35	10	Screw-Set HSH 1/4-28 X 1/4
10	121-4936-03	1	Plate-Bearing	22	116-9860	2	Sprocket ASM
11	121-4937	1	Shaft-Output	23	121-4932-03	1	Bracket-Support, Shaft
12	3230-23	14	Bolt-Carriage 5/16-18 X 3/4 Short Neck	24	121-6105	2	Chain-Drive Wheel #40
13	3230-8	2	Bolt-Carriage 5/16-18 X 2 1/2	25	121-6108	1	Shaft-Jack
14	104-8300	20	Nut-Nyloc 5/16-18 Flg	26	3235-6	2	Screw-HH 5/16-24 X 3/4
15	3234-4	2	Screw-HH Flg 1/4-20 X 3/4	27	105-3828	1	Spacer
				28	94-9524	1	Spacer-Control

● Use Pro-Lock, Nut Type (P/N 1-840022, .5ml tube) on threads.

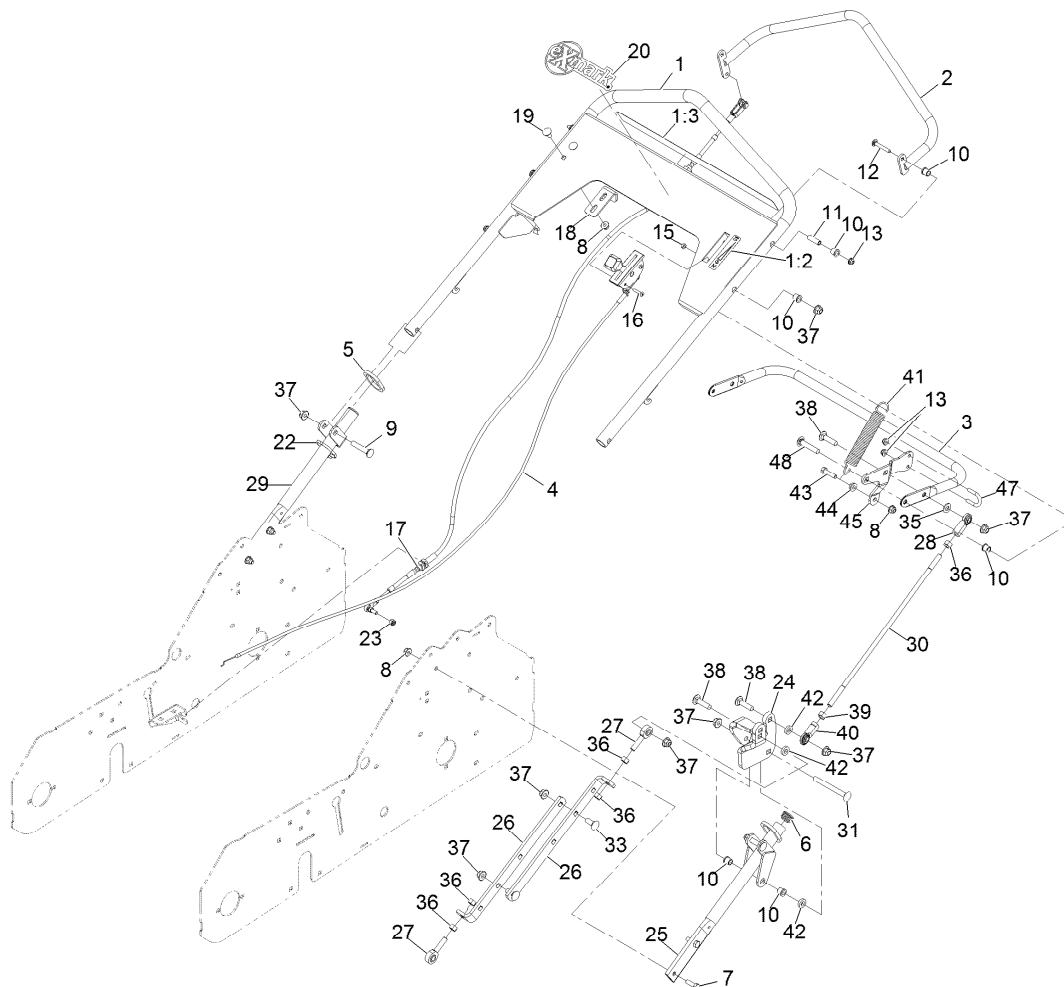

Handle Assembly

Ref.	Part Number	Qty.	Description	Ref.	Part Number	Qty.	Description
1	126-0639	1	Handle W/ Decals	23	3296-3	1	Nut-Nyloc 1/4-28
1:2	121-6151	1	Decal-Throttle, Choke	24	126-1656-03	1	Bracket-Trunnion
1:3	116-8699	1	Decal-Aerator Control Panel	25	116-9883-03	1	Asm-Lower Handle
2	121-6053-03	1	Tube-Control	26	126-0841-03	2	Link-Lift
3	116-9873-03	1	Tube-Handle Lift	27	1-613204	2	Balljoint
4	116-9898	1	Control-Throttle	28	103-0608	1	Balljoint
5	121-6202	2	Ring-Handle Lock	29	121-1893-03	1	Handle-Lower
6	121-4870	2	Plug	30	116-9893	1	Rod-Upper Link
7	322-5	4	Screw-HH 5/16-18 X 1	31	3231-24	1	Bolt-Carriage 3/8-16 X 3 3/4
8	104-8300	7	Nut-Nyloc 5/16-18 Flg	33	3231-2	2	Bolt-Carriage 3/8-16 X 1
9	3231-6	2	Bolt-Carriage 3/8-16 X 2	35	3256-24	1	Washer-3/8 Sae
10	103-9928	10	Bearing	36	3219-3	5	Nut-Hex 3/8-24
11	121-6060	3	Bushing-Pivot	37	104-8301	9	Nut-Nyloc 3/8-16 Flg
12	3229-5	3	Screw-CARR	38	3231-4	3	Bolt-Carriage 3/8-16 X 1 1/2
13	104-7201	5	Nut-Nyloc 1/4-20 Flg	39	3219-20	1	Nut-Hex 3/8-24 LH
15	3296-2	2	Nut-Nyloc #10-24	40	103-1167	1	Joint-Ball End
16	3250-27	2	Screw-PPH #10-24 X 7/8	41	106-2177	1	Spring-Extension
17	121-6068	1	Cable	42	80-7730	3	Spacer
18	121-6057	1	Angle-Stop	43	322-6	1	Screw-HH 5/16-18 X 1 1/4
19	3230-18	2	Bolt-Carriage 5/16-18 X 5/8	44	32128-20	1	Nut-Whizlock 5/16-18
20	103-3999	1	Decal, Exmark Logo (Console)	45	126-1657-03	1	Bracket-Spring
22	3290-378	1	Tie-Cable	47	01-170-0040	1	U-Bolt
				48	117-9971	1	Bolt-Carriage

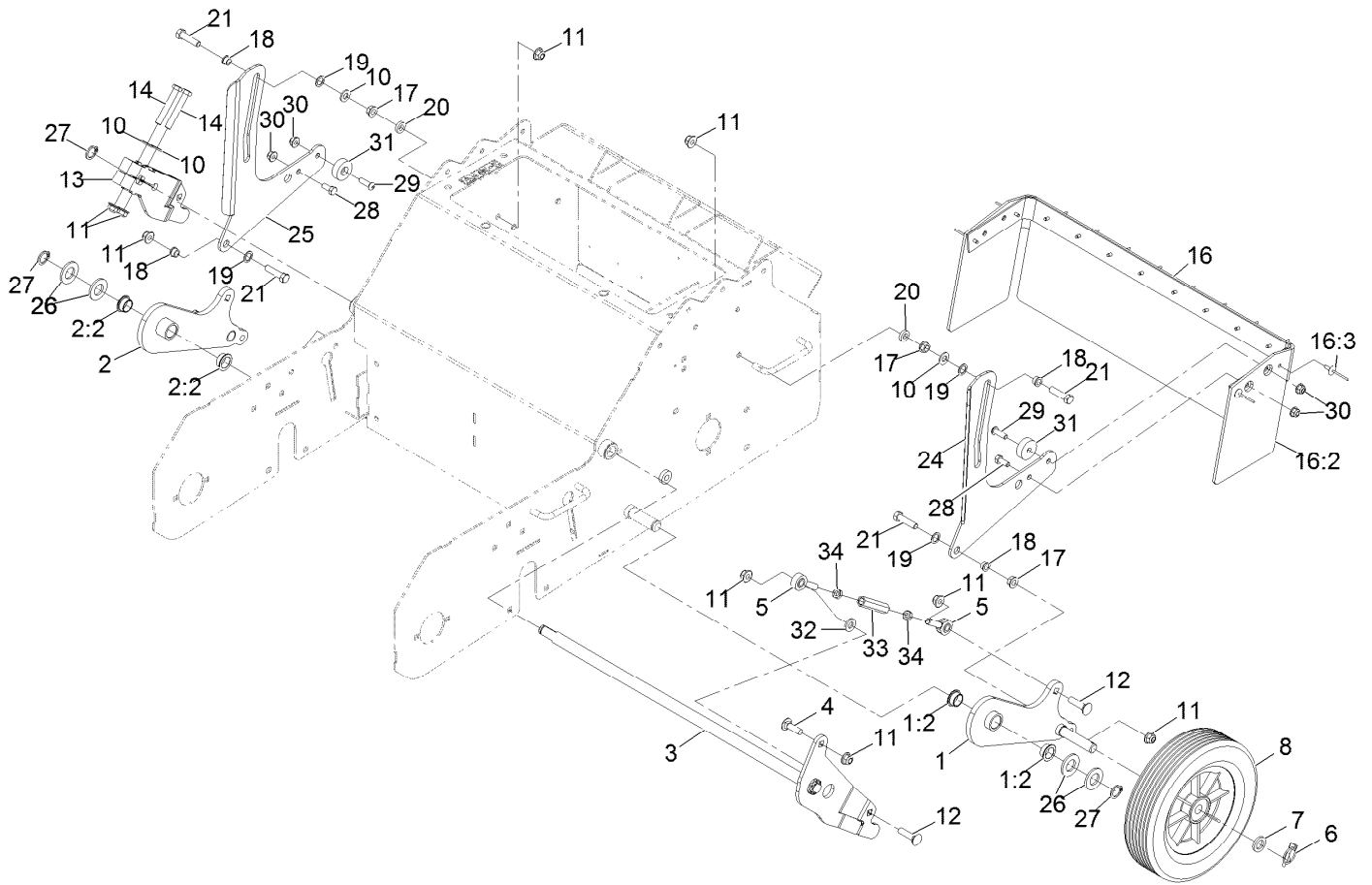

Height Linkage Assembly

Ref.	Part Number	Qty.	Description	Ref.	Part Number	Qty.	Description
1	126-0829	1	Wheel Arm ASM-LH W/Brgs	16:3	3269-20	12	Rivet-Pop
1:2	108519	2	Bushing-Bronze	17	3290-357	4	Nut-Whizlock 3/8-16
2	126-0830	1	Wheel Arm ASM-RH W/Brgs	18	1-603735	4	Bushing-Flanged
2:2	108519	2	Bushing-Bronze	19	94-8196	4	Washer-Nylon
3	126-1343	1	Shaft-Pivot	20	80-7730	2	Spacer
4	3231-25	1	Bolt-Carriage 3/8-16 X 1 1/4	21	323-8	4	Screw-HH 3/8-16 X 1 1/2
5	1-613204	4	Balljoint	24	126-0824-01	1	Arm-Guard LH
6	3290-495	2	Pin-Klik	25	126-0825-01	1	Arm-Guard RH
7	63-9710	2	Spacer-Bearing	26	3256-28	4	Washer-3/4 Sae
8	121-4897	2	Wheel-Transport	27	32120-93	3	Ring-Retaining
10	3256-24	4	Washer-3/8 Sae	28	322-3	2	Screw-HH 5/16-18 X 3/4
11	104-8301	11	Nut-Nyloc 3/8-16 Flg	29	109-4872	2	Screw-Hsph 5/16-18 X 1
12	3231-4	4	Bolt-Carriage 3/8-16 X 1 1/2	30	104-8300	4	Nut-Nyloc 5/16-18 Flg
13	126-1345-03	1	Arm-Lift RH	31	116-8331	2	Guide-Trail Arm
14	323-12	2	Screw-HH 3/8-16 X 2 1/2	32	87-7480	2	Washer
16	126-0564	1	Foot Guard	33	116-9855	2	Rod-Lift Link
16:2	116-9884	1	Shield Foot	34	3220-3	4	Nut-Jam 3/8-24

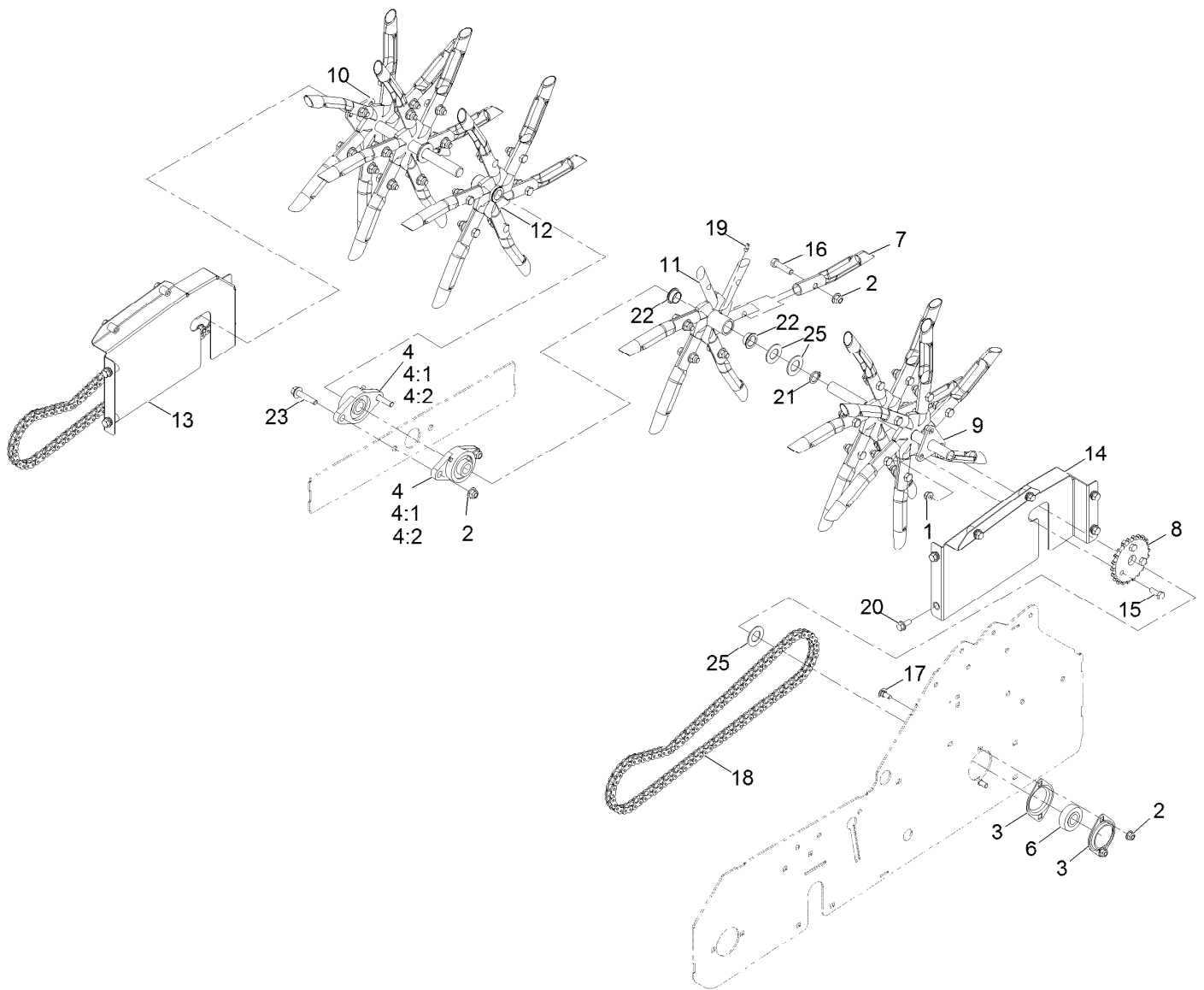

Tine Assembly

Ref.	Part Number	Qty.	Description	Ref.	Part Number	Qty.	Description
1	104-8300	10	Nut-Nyloc 5/16-18 Flg	13	126-1204	1	ASM-Chain Guard, RH
2	104-8301	38	Nut-Nyloc 3/8-16 Flg	14	126-1206	1	ASM-Chain Guard, LH
3	105-9714	4	Flange-Bearing	15	322-4	6	Screw-HH 5/16-18 X 7/8
4	106-7126	2	Bearing-Flange	16	323-8	36	Screw-HH 3/8-16 X 1 1/2
4:1	302-58	1	Fitting-Straight	17	3230-1	4	Bolt-Carriage 5/16-18 X 3/4
4:2	3245-35	2	Screw-Set HSH 1/4-28 X 1/4	18	121-6107	2	Chain-Drive
6	120-9350	2	Bearing-Lock, Collar	19	302-19	2	Zerk-1/4-28 Str
7	121-4894	36	Tine-Coring	20	3234-47	12	Screw-HH Flg 5/16-18 X 3/4
8	116-9896	2	Sprocket-#40 22T	21	32120-93	2	Ring-Retaining
9	121-4930	1	Tine-Wheel LH	22	108519	4	Bushing-Bronze
10	121-6072	1	Tine-Wheel RH	23	3234-19	2	Screw-HHF 3/8-16 X 1 3/4
11	121-6099	1	Spyder Tine Wa	25	69-8930	6	Washer
12	121-6096	1	Spyder Tine Wa				

EXMARK® MAINTENANCE

MAXIMIZE THE PERFORMANCE OF YOUR EXMARK.

4-CYCLE PREMIUM ENGINE OIL

Part No. 116-3373

Both SAE 30 and SAE 10W-30 in one bottle.

Contains increased levels of zinc and phosphorus for better lubricity.

No Viscosity Index Improvers that tend to shear down in high heat.

Synthetic formulation.

Gas & Diesel compatible.

Anti-corrosion additives.

API 'SL' and JASO rated with wet clutch compatibility for other machines.

PREMIUM HYDRO OIL

Part No. 109-9828

Commercial quality for tough, high-heat conditions.

Designed specifically for zero-turn mower hydraulic systems.

Superior shear resistance under heavy loads.



Available from your local Exmark dealer. Find your closest dealer at exmark.com

EXMARK ACCESSORIES AND OPTIONS*

MID-MOUNT RIDING ACCESSORIES AND OPTIONS

CUSTOM RIDE SEAT SUSPENSION SYSTEM	OPERATOR CONTROLLED DISCHARGE
FULL SUSPENSION SEAT	SUN SHADE
DECK LIFT ASSIST KIT	TRASH CONTAINER
HITCH KIT	TURF STRIPER
LIGHT KIT	ULTRA VAC COLLECTION SYSTEM
12V POWER PORT	ULTRA VAC QUICK DISPOSAL SYSTEM
MICRO-MULCH SYSTEM	

OUT-FRONT RIDING ACCESSORIES AND OPTIONS

CUSTOM RIDE SEAT SUSPENSION SYSTEM	SNOW BLADE
DUAL-TAIL WHEEL	SNOWBLOWER
FLOOR PAN EXTENDER	SUN SHADE
HITCH KIT	TRASH CONTAINER
LIGHT KIT	ULTRA VAC COLLECTION SYSTEM
MICRO-MULCH SYSTEM	ULTRA VAC QUICK DISPOSAL SYSTEM
ROLL OVER PROTECTION SYSTEM (ROPS)	WEATHER CAB

WALK-BEHIND ACCESSORIES AND OPTIONS

GRASS CATCHER	TURF STRIPER
MICRO-MULCH SYSTEM	STANDON

*Some accessories and options not available for some models.

Place Model No. and Serial No.
Label Here (Included in the Literature
Pack) or Fill in Below

Model No. _____

Serial No. _____

Date Purchased _____

Engine Model No. and Spec. No. _____

Engine Serial No. (E/No) _____

© 2013 Exmark Mfg. Co., Inc.
Industrial Park Box 808
Beatrice, NE 68310
All Rights Reserved

Part No. 4501-688 Rev. A
(402) 223-6300
Fax (402) 223-5489
Printed in the USA.

