

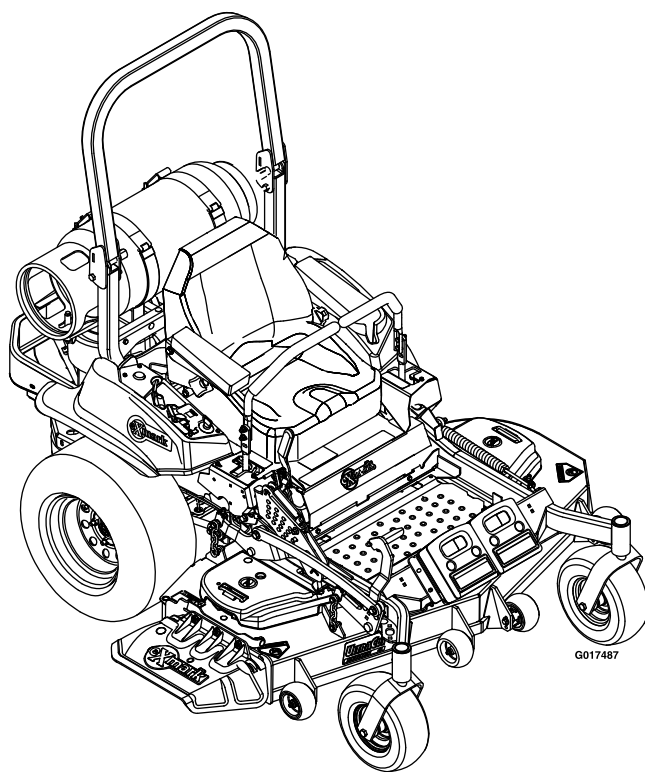

LAZER Z[®] PROPANE

Model No. LZS740PKC724—Serial No. 31300000 and Up

Picture below may not reflect actual product.



Parts Manual

Ordering Replacement Parts

To order replacement parts, please supply the part number, the quantity, and the description of each part desired.

Understanding Reference Numbers

Each identified part in an illustration has a reference number. The reference number for a part also appears in the parts list, along with other information about the part.

This catalog uses two special reference number formats, one to indicate parts in a service assembly and another to indicate the quantity of a given part in an illustration.

Service Assembly Reference Numbers

Parts in service assemblies have reference numbers in the form a:b. The a represents the reference number of the entire service assembly and the b represents a sequential number unique to each part within the service assembly.

For example, a wheel assembly might be identified by reference number 6, the tire by 6:1, the valve by 6:2, and the wheel by 6:3. When you order the assembly identified by reference number 6, you receive all parts identified by reference numbers 6:1, 6:2, and 6:3. However, you may also order any part individually. Reference numbers of this type appear in illustration and in parts lists.

Reference Numbers Indicating Quantity

In an illustration, if a reference number indicates more than one part, the reference number has the form nX y. The n represents the quantity of the part, the X is the multiplication symbol, and the y represents the reference number.

For example, in an illustration, the reference number 2X 37 means that two of the parts identified by reference number 37 are indicated.

List of Abbreviations

AR: as required	HJ: hex jam	PRH: phillips round head
ASM: assembly	HLH: hex lag head	PTH: phillips truss head
BBC: blade brake control	HOC: height-of-cut	PTO: power-take-off
BHTF: button head thread forming	HSBH: hex socket button head	RH: right hand
CARR: carriage	HSFH: hex socket flat head	ROPS: roll-over protection system
CCW: counter clockwise	HSH: hex socket head	RRB: rear roller brush
CW: clockwise	HWH: hex washer head	SFH: slotted fillister head
DEG: degrees	HWHTF: hex washer head thread forming	SHH: slotted hex head
DPA: Dual Point Adjustment	HYD: hydraulic	SHWH: slotted hex washer head
ECM: electronic control module	LH: left hand	SPH: slotted pan head
EXT: external	LP: Liquefied Petroleum Gas	SQH: square head
FH: flat head	LPG: Liquefied Petroleum Gas	SRH: slotted round head
GA: gauge	NI: nylon insert	STD: standard
HD: heavy-duty	NPTF: national pipe thread fine	TAP: self tapping
HF: hex flange	PFH: phillips flat head	TTH: torx truss head
HH: hex head	PPH: phillips pan head	
HHF: hex head flange	PPHTF: phillips pan head thread forming	
HHFTF: hex head flange thread forming		

Touch Up Paint

Exmark black touch up spray paint – gloss black.

Exmark red touch up paint (spray paint – P/N 1-850337 - .6 oz liquid bottle – P/N 103-9140).



If your Exmark dealer does not have the Exmark part in stock, Exmark will get the parts to the dealer the next business day or the part will be FREE Guaranteed!! (Some restrictions apply. See your participating Exmark Dealer for details.)

Contents

Complete Deck Assembly.....	4
Deck Assembly.....	5
Deck W/Decals Assembly No. 116-1665.....	6
Main Frame Assembly.....	7
Roll-Over Protection System Assembly No. 116-2882.....	9
Deck Idler Assembly No. 116-3755.....	10
Caster Wheel and Fork Assembly.....	11
Deck Lift Assembly.....	12
Height-of-Cut Assembly No. 109-7438.....	13
Control Assembly.....	14
Motion Control Assembly.....	15
Rear Wheel and Park Brake Assembly.....	16
Parking Brake Handle Assembly No. 116-7551.....	17
Seat Assembly.....	18
Seat W/Tracks Assembly No. 116-4474.....	19
Fuel Assembly.....	20
Engine Assembly.....	21
Hydraulic Assembly.....	22
LH Hydro Assembly No. 116-6413.....	23
RH Hydro Assembly No. 116-6414.....	24
Pump Idler Assembly No. 116-1255.....	25
Electrical Assembly.....	26

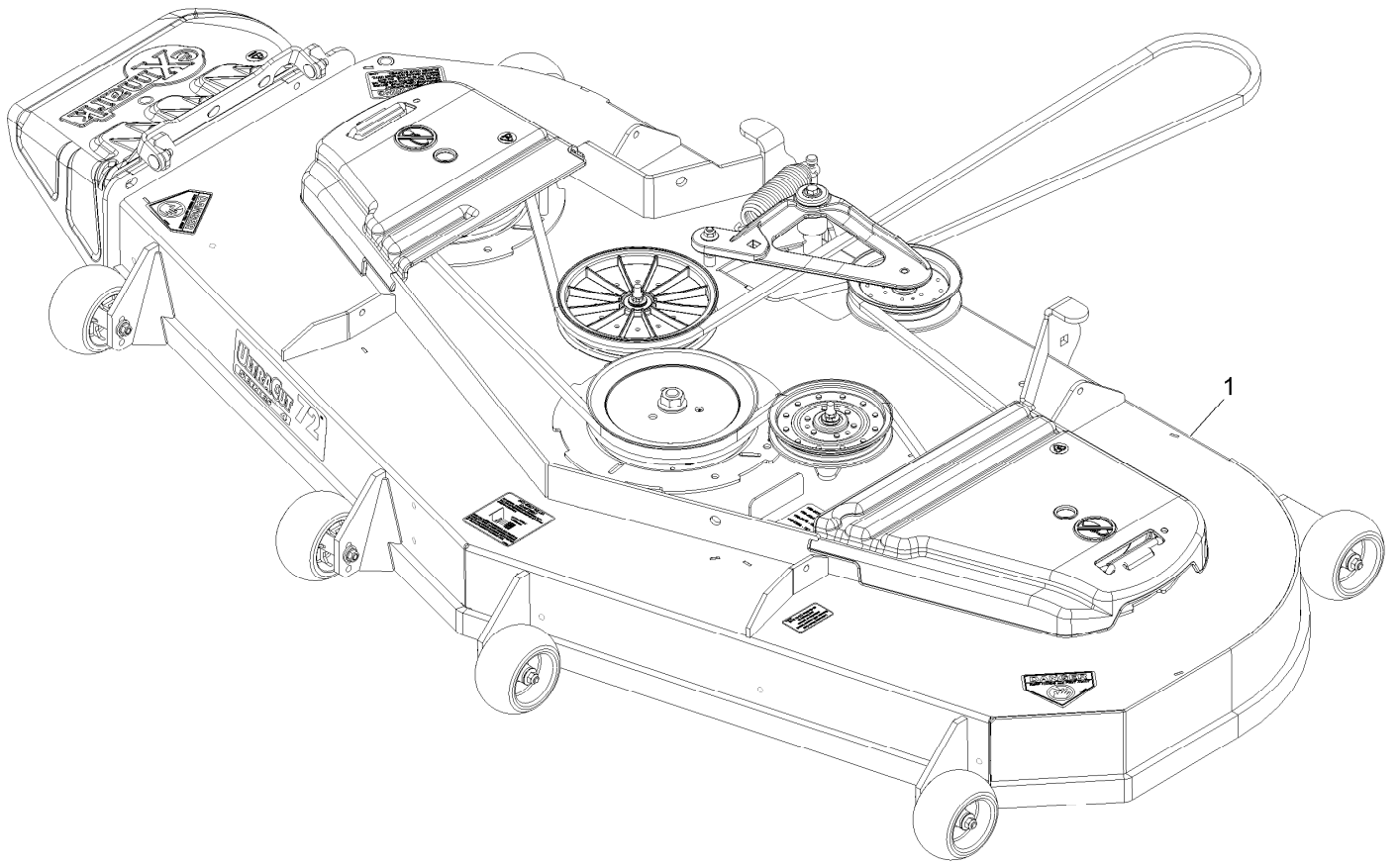

Complete Deck Assembly

<i>Ref.</i>	<i>Part Number</i>	<i>Qty.</i>	<i>Description</i>
1	116-3600	1	ASM,724 Deck Complete

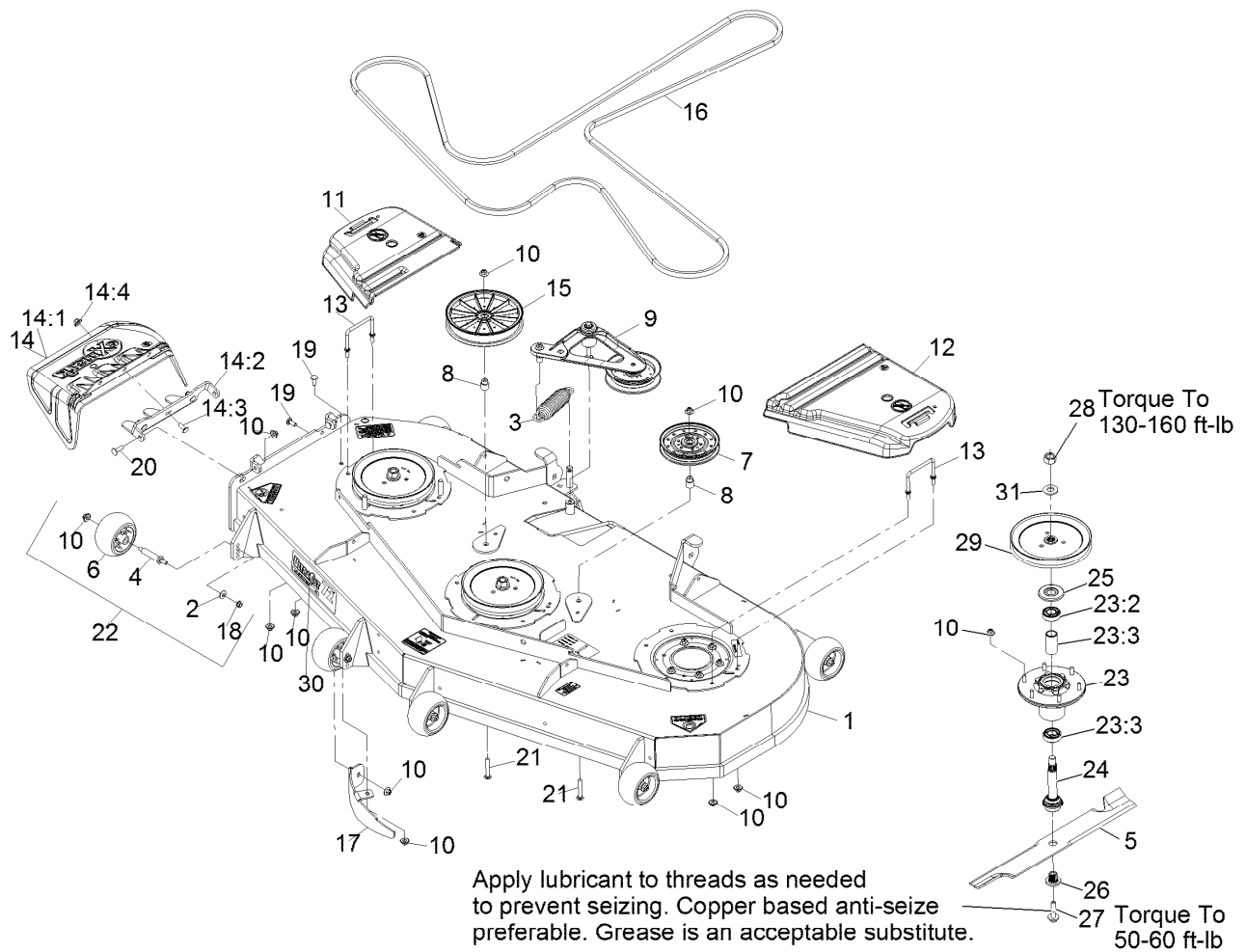

Deck Assembly

Ref.	Part Number	Qty.	Description	Ref.	Part Number	Qty.	Description
1	116-1665	1	ASM,Deck W/Decals 724	15	109-0996	1	Pulley,Idler 8"flat
2	98-5975	6	Washer-Spring Disc 3/8	16	109-9023	1	Belt,V-5V X 219.00"
3	116-6317	1	Spring-Extension	17	116-5834-01	1	Baffle-Dogleg, Lz72
4	99-2842	6	Spacer	18	3290-357	6	Nut-Whizlock 3/8-16
5	103-6384	3	Blade, Solid (72")	19	3231-22	2	Bolt-Carriage 3/8-16 X 1
5	103-6389	3	Blade, Low Lift (72")	20	3231-28	2	Bolt-Carriage 3/8-16 X 1 1/4
5	103-6394	3	Blade, Mulching (72")●	21	3231-44	2	Bolt-Carriage 3/8-16 X 2 1/2
5	103-6404	3	Blade, Notched (72")	22	103-4051	6	Kit, Antiscalp Roller (44" And 48")
5	116-5171	3	Blade-Extreme 2, 24.50"	23	116-3344	3	ASM-Cutter Hsg With Bearings
6	1-603299	6	Roller-Scalp, Anti	23:2	116-0720	2	Bearing-Ball
7	116-4667	1	Idler-Pulley, Flat	23:3	116-3312	1	Spacer-Bearing
8	1-633456	2	Bushing, Idler	24	116-3341	3	ASM-Spindle And Seal
9	116-3755	1	Deck Idler ASM	25	116-1286	3	Guard,Bearing Top .989
10	109-6658	34	Nut-Nyloc 3/8-16 Flg	26	103-3037	3	Bushing, Splined
11	116-0094	1	Cover-Belt, RH	27	109-9220	3	Screw-Sems 1/2-20 X 2.19
12	109-6938	1	Cover-Belt, LH	28	116-7306	3	Nut-Hex
13	109-6982	2	Wireform-Cover	29	116-1377	3	Sheave,Blade Drive 8.74
14	109-7188	1	ASM,Discharge Chute	30	116-0944	1	Decal,Ultracut 72 Series 4
14:1	109-2738	1	Chute, Discharge	31	103-2802	3	Washer-Spring Disc 3/4
14:2	109-8675-01	1	Bracket,Discharge Chute				
14:3	3231-22	3	Bolt-Carriage 3/8-16 X 1				
14:4	109-6658	3	Nut-Nyloc 3/8-16 Flg				

● Requires installation of mulch kit for proper mulching. See your Exmark dealer for details.

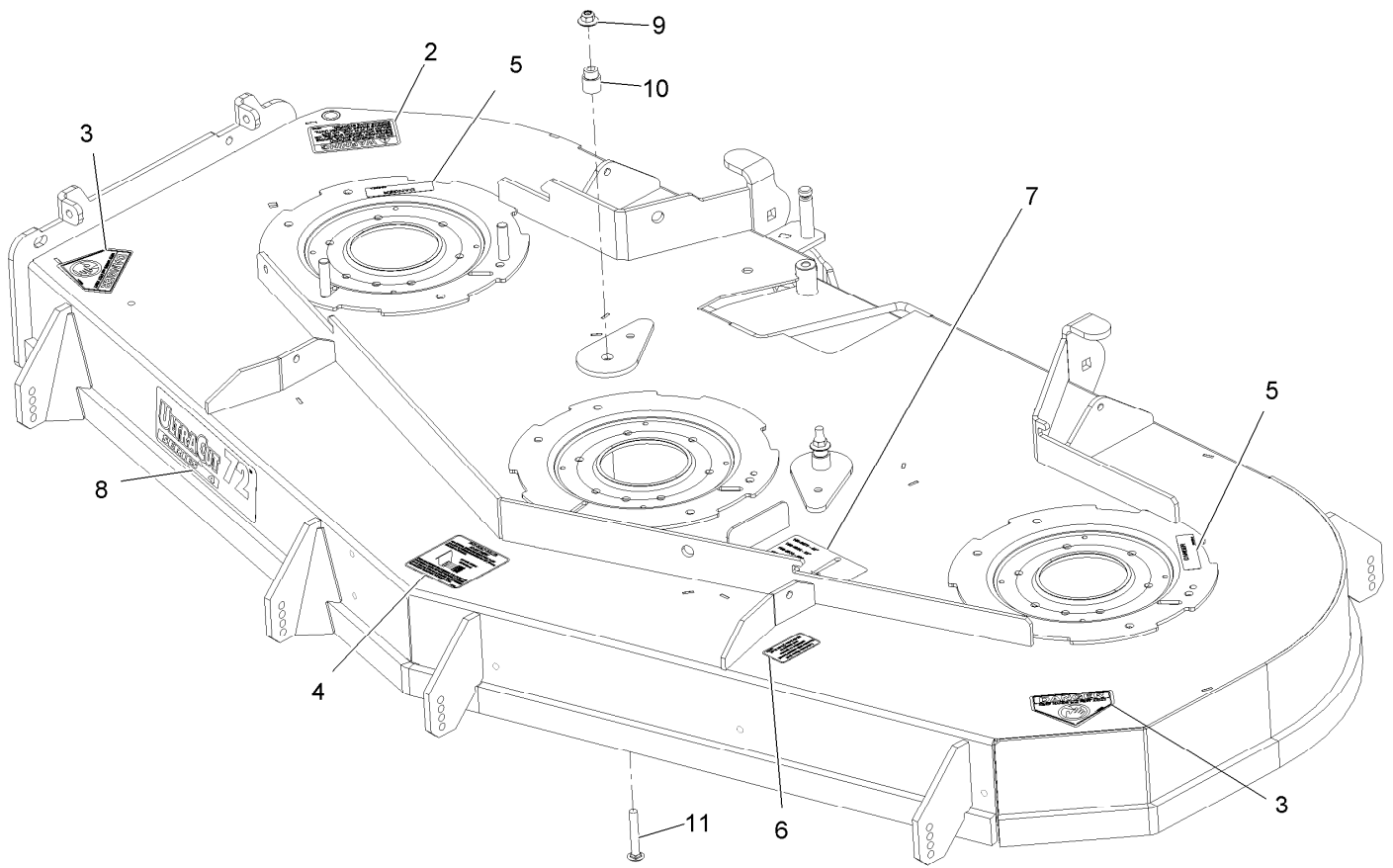

Deck W/Decals Assembly No. 116-1665

Ref.	Part Number	Qty.	Description
2	1-303508	1	Decal-Warning, Discharge
3	1-403005	2	Decal-Danger
4	1-633922	1	Decal, Anti-Scalp
5	98-5954	2	Decal-Cover, Missing
6	109-3148	1	Decal, Bolt Torque
7	109-9361	1	Decal,Belt Routing
8	116-0944	1	Decal,Ultracut 72 Series 4
9	109-6658	2	Nut-Nyloc 3/8-16 Flg
10	1-633456	2	Bushing, Idler
11	3231-44	2	Bolt-Carriage 3/8-16 X 2 1/2

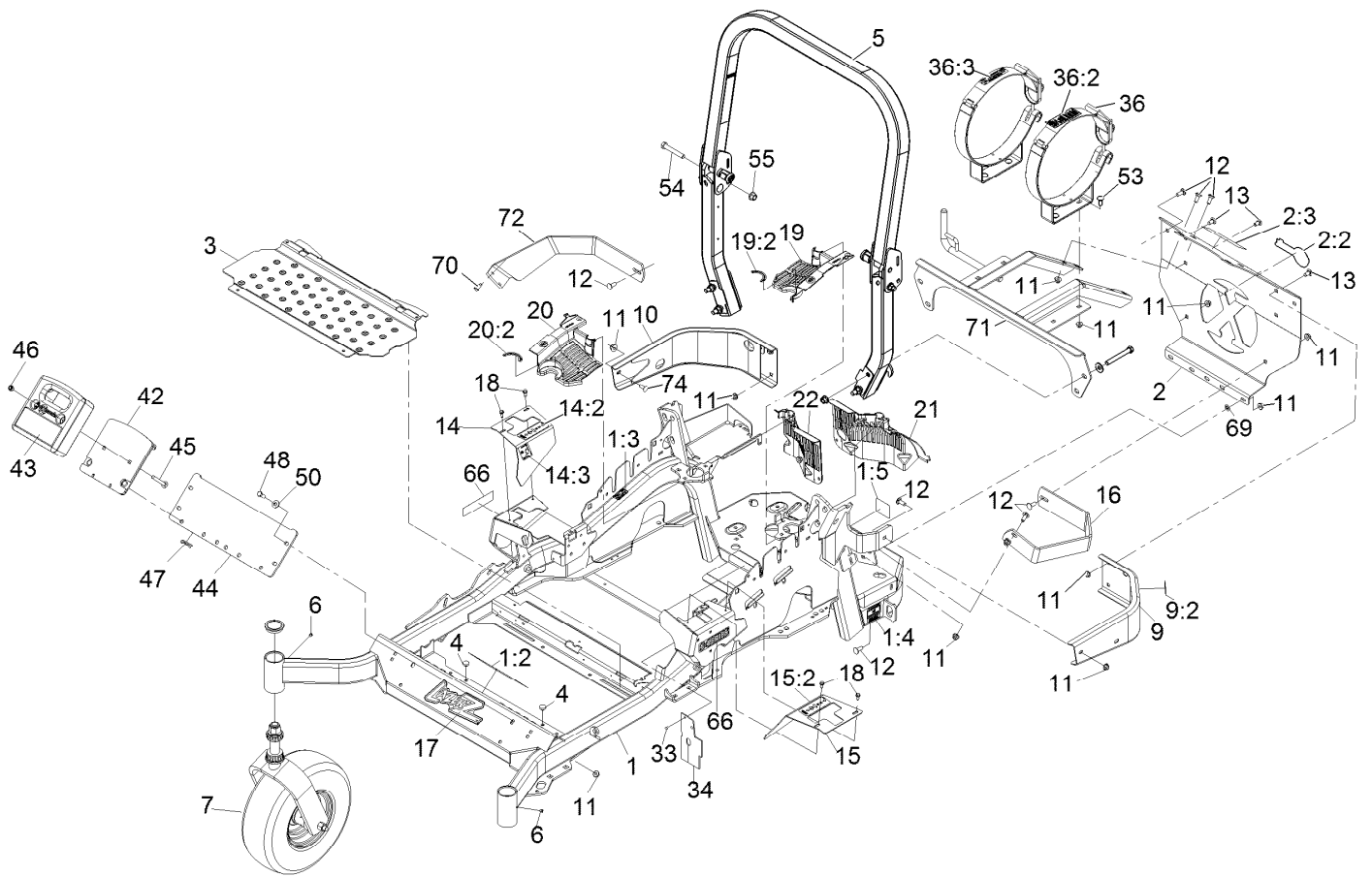

Main Frame Assembly

Ref.	Part Number	Qty.	Description	Ref.	Part Number	Qty.	Description
1	116-5904	1	Mainframe ASM	14	116-5899	1	RH Motion Control Cover ASM
1:2	103-2076	2	Decal-Caution	14:2	109-7232	1	Decal-Motion Control
1:3	116-3303	1	Decal-Slope	14:3	116-5944	1	Decal-Park Brake
1:4	116-0205	2	Decal-Belt Drive	15	116-0580	1	LH Motion Control Cover ASM
1:5	116-4858	1	Decal-Spark Arrester	15:2	109-7232	1	Decal-Motion Control
2	116-9304	1	Rear Guard-LP W/Decals	16	116-0043-03	1	Guard-Muffler
2:2	103-2883	1	Decal, Exmark Logo	17	103-3113	1	Decal, Lazer Model
2:3	109-9906	1	Decal-Tank Replacement	18	32144-10	4	Screw-HWH 1/4-20 X .62
3	116-8898-01	1	Floorpan	19	116-0170	1	LH Hydro Guard ASM
4	1-513658	2	Bumper	19:2	116-0157	1	Decal-Hydro Oil
5	116-2882	1	ROPS ASM	20	116-0171	1	RH Hydro Guard ASM
6	1-811010	2	Plug	20:2	116-0157	1	Decal-Hydro Oil
7		2	Caster Wheel ASM ●	21	109-9057	1	Guard-Hydro, Rear LH
9	116-0180	1	LH Bumper ASM	22	109-9058	1	Guard-Hydro, Rear RH
9:2	103-2076	1	Decal-Caution	33	1-803035	2	Rivet 3/16 X 1/4
10	116-0057-03	1	Bumper-RH	34	116-2362	1	Deflector-Air Flow
11	104-8301	26	Nut-Nyloc 3/8-16 Flg	36	116-2817	1	Tank Bracket ASM (Set)
12	3231-22	12	Bolt-Carriage 3/8-16 X 1				
13	3231-21	5	Bolt-Carriage 3/8-16 X 3/4				

● Not serviced separately

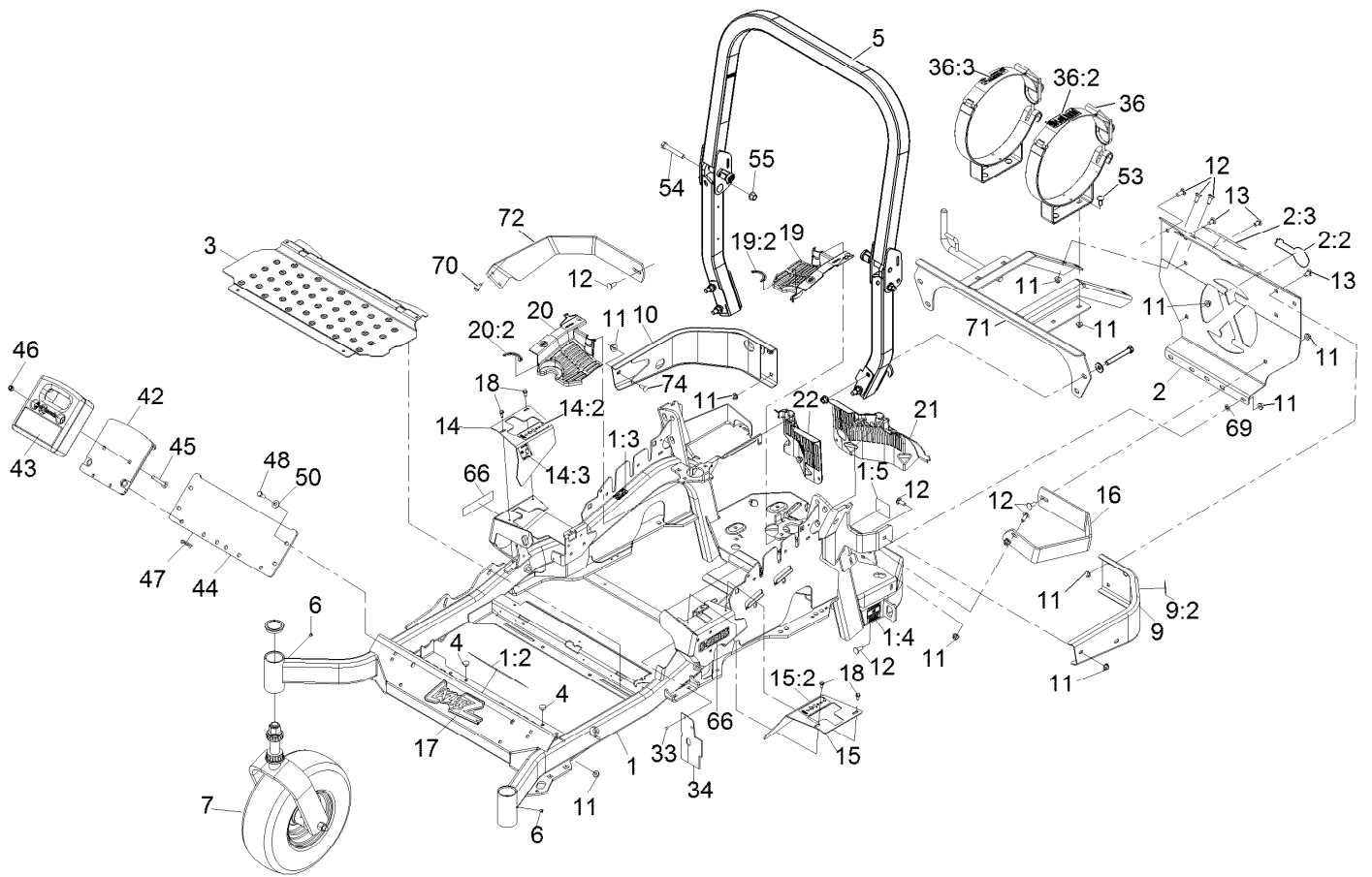

Main Frame Assembly (continued)

Ref.	Part Number	Qty.	Description	Ref.	Part Number	Qty.	Description
36:2	109-9875	1	Decal-LPG Warning	53	3231-2	4	Bolt-Carriage 3/8-16 X 1
36:3	116-1714	1	Decal-LPG 43.5Lb Tank	54	325-13	1	Screw-HH 1/2-13 X 3 1/4
42	103-6364-01	2	Asm, Weight W/Decals	55	99-5107	1	Nut-Lock 1/2-13
43	103-6367-01	2	Weight,Cast 36Lb	66	116-3884	2	Decal-S-Series
44	103-6368-01	1	Plate, Weight Mounting	69	107-3154	2	Nut-Push 3/8-16
45	3231-10	4	Bolt-Carriage 3/8-16 X 3	70	32144-70	2	Screw-HWH 5/16-18 X 3/4 Tf
46	3296-39	4	Nut-Nyloc 3/8-16	71	116-3558-03	1	Support-LPG Tank
47	9335124	4	Hairpin-Cotter	72	116-1432-03	1	Strap-Guard
48	323-6	9	Screw-HH 3/8-16 X 1	74	3231-25	1	Bolt-Carriage 3/8-16 X 1 1/4
50	98-5975	4	Washer-Spring Disc 3/8				

● Not serviced separately

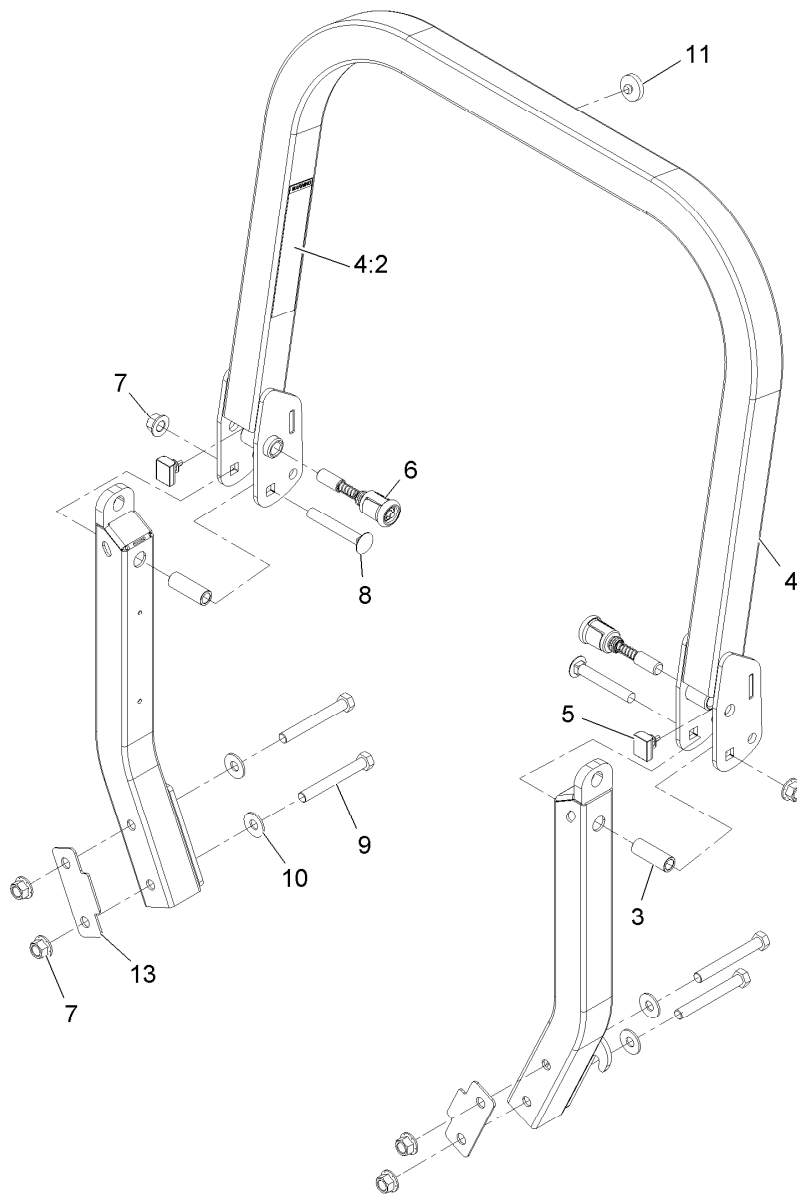

Roll-Over Protection System Assembly No. 116-2882

<i>Ref.</i>	<i>Part Number</i>	<i>Qty.</i>	<i>Description</i>
3	109-6653	2	Spacer
4	116-0019	1	Upper ROPS ASM
4:2	107-2102	1	Decal-Warning, Folding ROPS
5	109-5337	2	Bumper-ROPS
6	116-0104	2	Pin-Spring
7	99-5107	6	Nut-Lock 1/2-13
8	3233-10	2	Bolt-Carriage 1/2-13 X 3 1/2
9	325-17	4	Screw-HH 1/2-13 X 4
10	109-9505	4	Washer-Spring
11	109-9233	1	Bumper-Push-In, Rubber
13	116-0960	2	Spacer

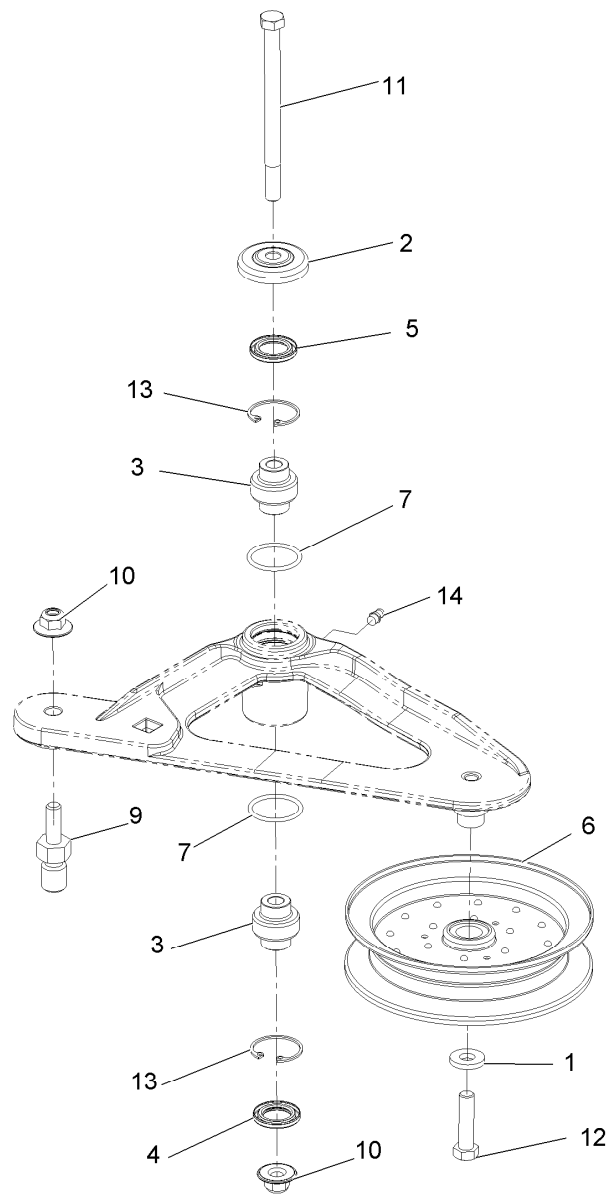

Deck Idler Assembly No. 116-3755

<i>Ref.</i>	<i>Part Number</i>	<i>Qty.</i>	<i>Description</i>
1	43-0940	1	Spacer
2	103-2916	1	Guard-Top
3	103-3504	2	Bearing-Spherical
4	103-3505	1	Seal-Double Lip
5	103-3506	1	Seal-Single Lip
6	116-4668	1	Idler-Pulley, Flanged
7	106-7159	2	O-Ring
9	116-3467	1	Pin-Spring, Anchor
10	109-6658	2	Nut-Nyloc 3/8-16 Flg
11	109-7409	1	Screw-Shoulder 3/8-16 X 5
12	323-8	1	Screw-HH 3/8-16 X 1 1/2
13	32120-10	2	Ring-Retaining
14	302-19	1	Zerk-1/4-28 Str

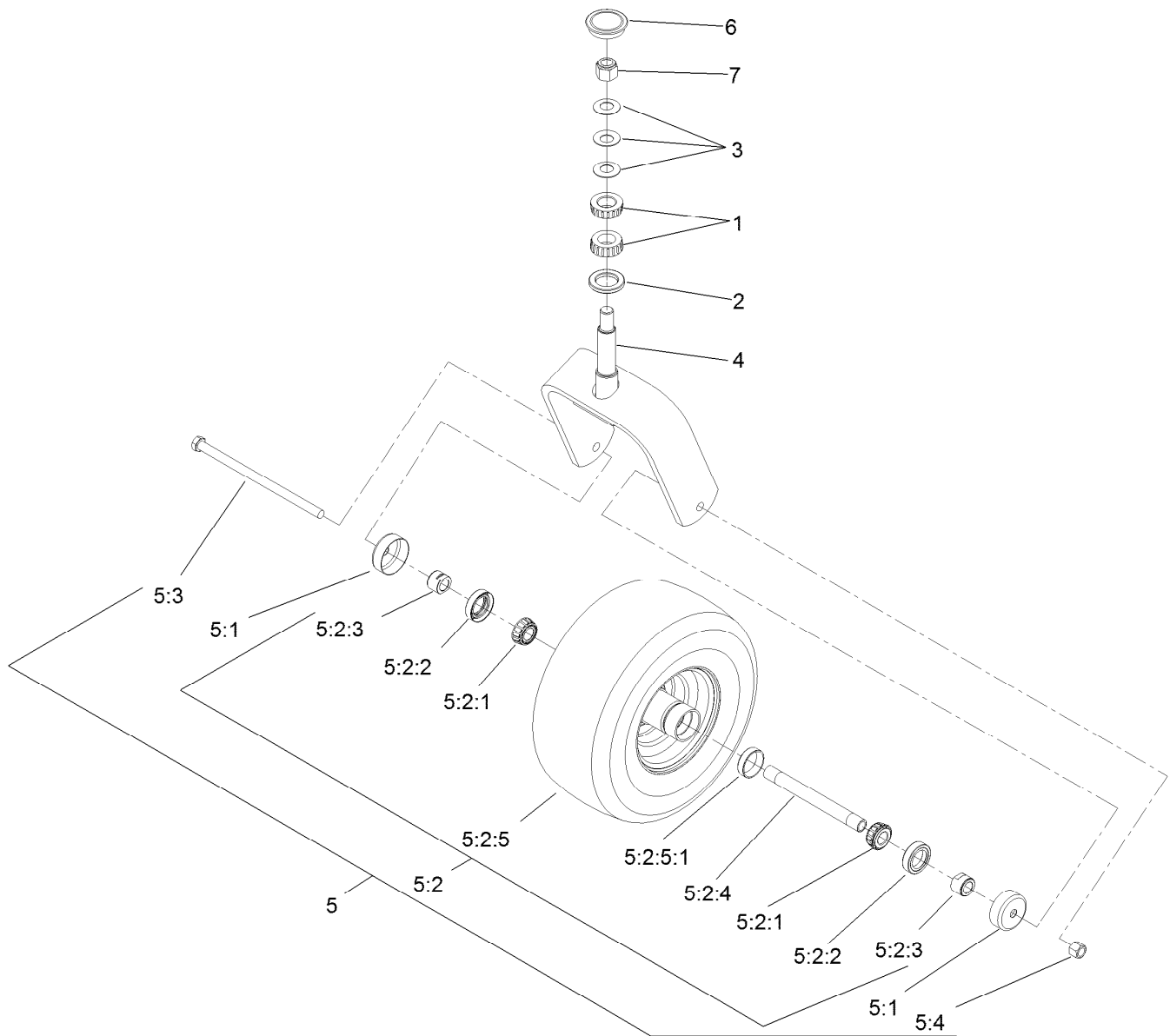

Caster Wheel and Fork Assembly

Ref.	Part Number	Qty.	Description	Ref.	Part Number	Qty.	Description
1	1-543509	2	Bearing-Roller, Tapered	5:2:3	103-3051	2	Spacer-Nut ■
2	116-5647	1	Seal-Grease	5:2:4	103-5156	1	Axle-Caster
3	1-633508	3	Washer-Bellville	5:2:5		1	Wheel And Tire ASM ●
4	116-6707-01	1	Caster	5:2:5:1	1-633584	1	Bearing-Cup
5	109-9127	1	Wheel And Tire ASM	5:3	325-39	1	Screw-HH
5:1	103-2768	2	Guard-Seal	5:4	3296-23	1	Nut-Lock, NI
5:2		1	Wheel And Tire ASM ●	6	103-4882	1	Cap-Grease
5:2:1	1-633585	2	Bearing-Cone, Taper	7	3296-51	1	Nut-Lock, NI
5:2:2	103-0063	2	Seal-Caster				

● Not serviced separately

■ Use Pro-Lock, Nut Type (P/N 1-840022, .5ml tube) on threads.

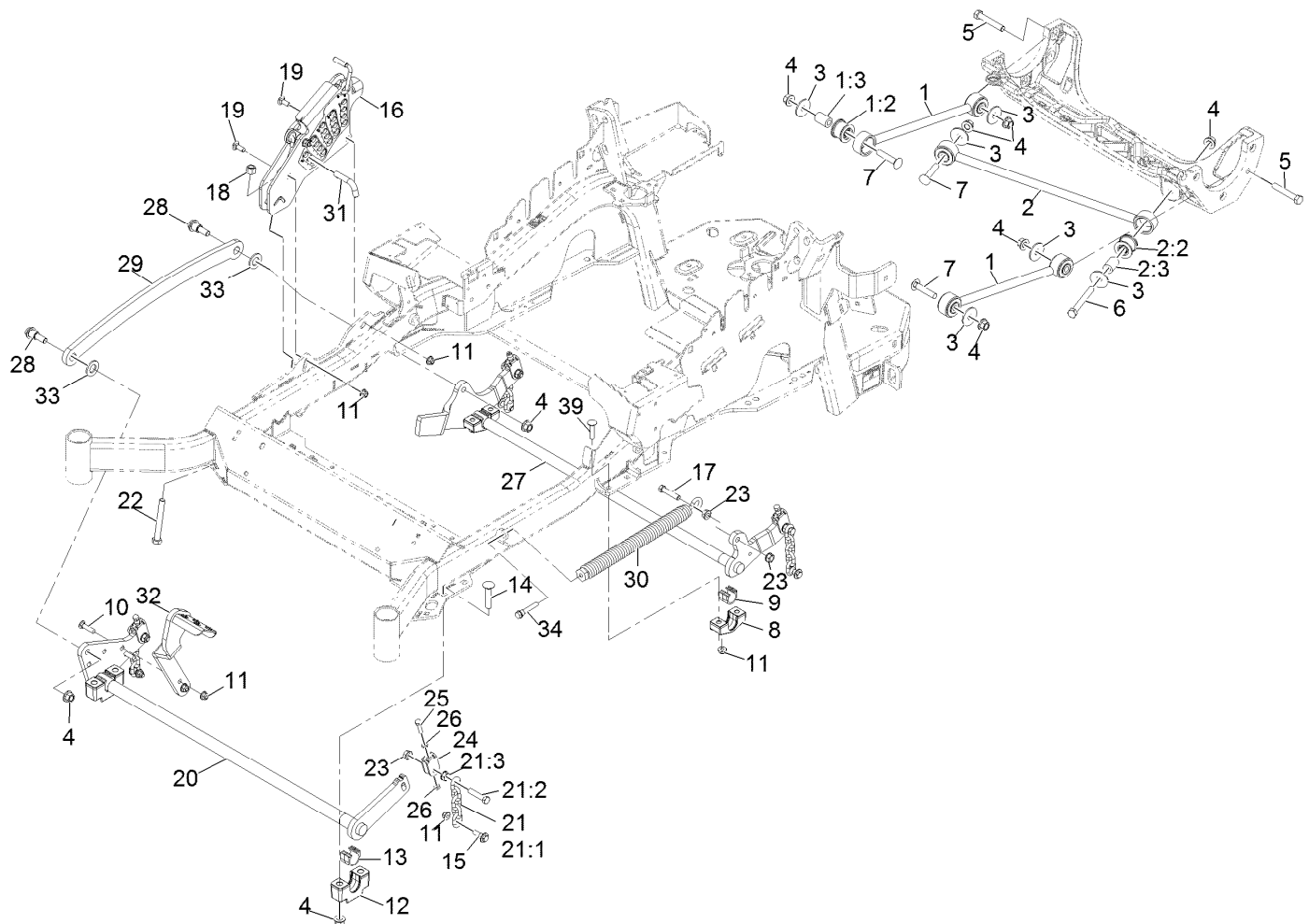

Deck Lift Assembly

Ref.	Part Number	Qty.	Description	Ref.	Part Number	Qty.	Description
1	109-7952	2	Deck Strut ASM	16	109-7438	1	HOC ASM
1:2	109-5009	2	Bushing-Suspension, Rubber	17	109-9065	1	Screw-HH 7/16-14 X 2
1:3	109-5010	2	Spacer	18	3296-23	1	Nut-Nyloc 1/2-13
2	109-5013	1	Panhard Rod ASM	19	3231-2	2	Bolt-Carriage 3/8-16 X 1
2:2	109-5009	2	Bushing-Suspension, Rubber	20	116-2217-03	1	Cross Shaft-Front
2:3	109-5010	2	Spacer	21	116-0756	4	Deck Lift Chain ASM
3	86-1990	6	Washer	21:1	1-633447	1	Chain-Lift, Deck
4	99-5107	12	Nut-Lock 1/2-13	21:2	109-9065	1	Screw-HH 7/16-14 X 2
5	325-12	2	Screw-HH 1/2-13 X 3	21:3	32128-37	1	Nut-Whizlock 7/16-14
6	325-17	1	Screw-HH 1/2-13 X 4	22	116-0559	1	Bolt-HH 1/2-13 X 4 Tap
7	3233-34	3	Bolt-Carriage 1/2-13 X 2 1/2	23	32128-37	6	Nut-Whizlock 7/16-14
8	116-0818-03	2	Support-Cross Shaft, Rear Bearing	24	109-9066	4	Yoke-Adjust, Deck
9	109-7173	2	Bearing-Cross Shaft, Rear	25	322-47	4	Screw-HH 5/16-18 X 1 1/4
10	3231-4	2	Bolt-Carriage 3/8-16 X 1 1/2	26	3218-2	8	Nut-Jam 5/16-18
11	104-8301	12	Nut-Nyloc 3/8-16 Flg	27	116-0459-03	1	Lift-Deck, Rear
12	109-9409	2	Support-Cross Shaft, Front Bearing	28	116-0780	2	Screw-Shoulder HHF 1/2-13 X 1.12
13	109-9410	2	Bearing-Cross Shaft, Front	29	116-0797-03	1	Link-Lift, Deck
14	116-1700	4	Bolt-Carriage 1/2-13 X 2 1/2 Spl Neck	30	116-0000	1	Extension Spring ASM
15	109-9840	4	Screw-Hex Flange 3/8-16 X .80	31	116-5584	1	Pin-HOC
				32	116-1919-01	1	Lever-Foot
				33	3256-28	2	Washer-3/4 Sae
				34	92-7674	1	Screw-Shcs 3/8-16 X 2.212
				39	3231-5	4	Bolt-Carriage 3/8-16 X 1 3/4

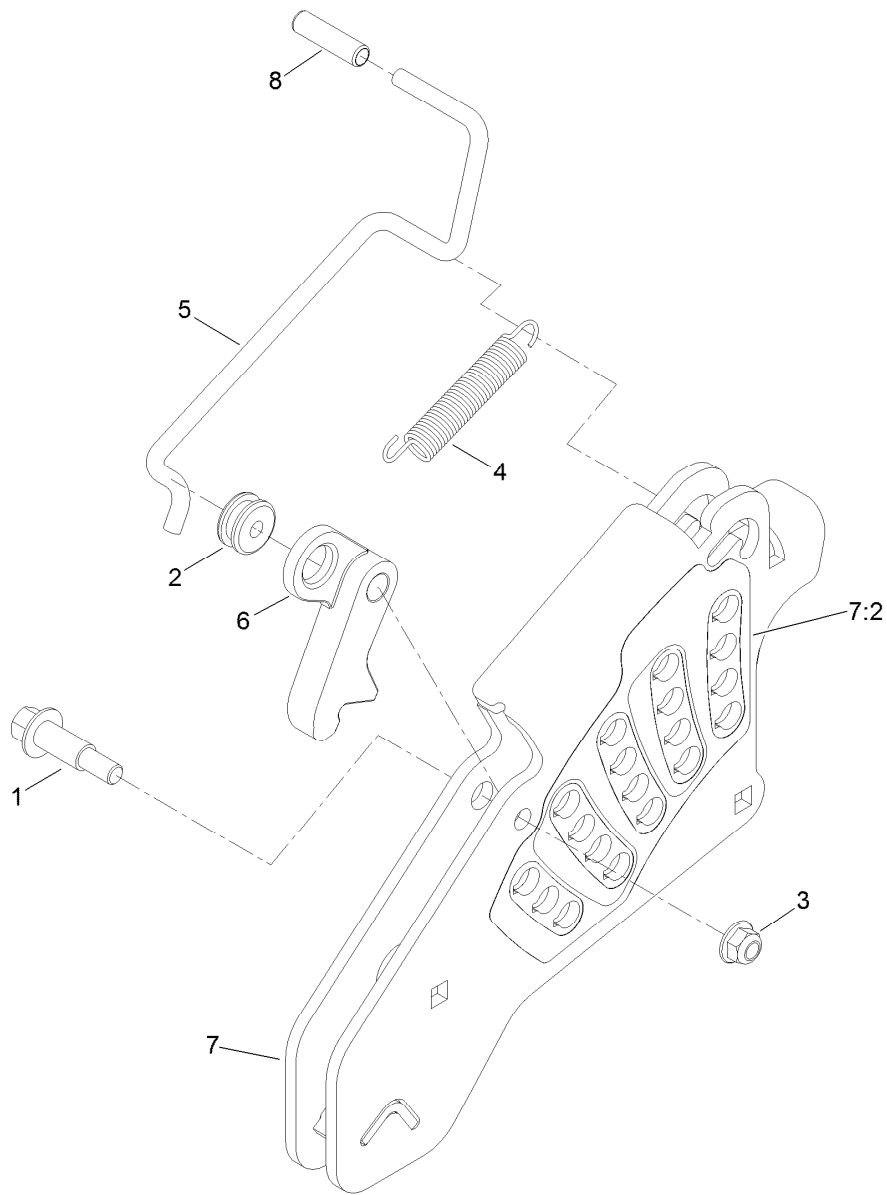

Height-of-Cut Assembly No. 109-7438

<i>Ref.</i>	<i>Part Number</i>	<i>Qty.</i>	<i>Description</i>
1	62-1330	1	Bolt-Shoulder
2	109-7130	1	Grommet
3	104-8301	1	Nut-Flange, NI
4	109-7124	1	Spring-Extension
5	109-7128	1	Rod-Lock, Transport
6	116-0118	1	Pawl-Transport, HOC
7	109-7335	1	HOC Plate ASM
7:2	116-0752	1	Decal-HOC
8	109-8250	1	Grip-Lever

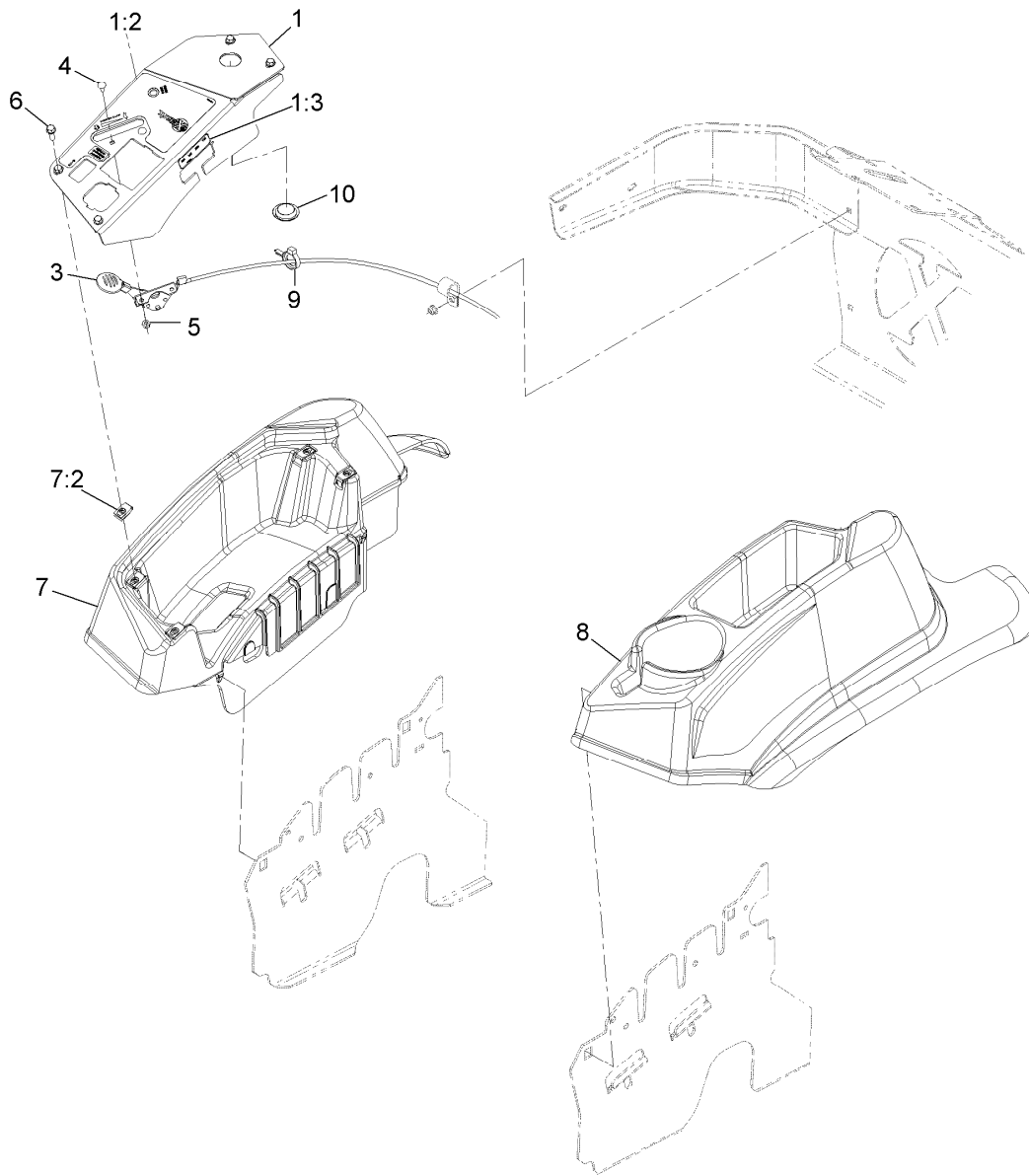

Control Assembly

Ref.	Part Number	Qty.	Description
1	116-2845	1	ASM,Control Panel W/Decal
1:2	116-2844	1	Decal,Control Panel Efi
1:3	109-7330	1	Decal-Fuse
3	116-0969	1	ASM,Throttle Cable
4	1-807513	2	Bolt-Carriage #10-24 X 1/2
5	3296-2	2	Nut-Nyloc #10-24
6	32105-15	4	Screw-Machine 1/4-20 X 3/4
7	116-1278	1	Console,RH As ASM
7:2	107069	4	Nut-Retainer-Panel 1/4-20
8	109-9457	1	Console, LH As
9	105-1853	1	Clamp-Hose
10	116-1875	1	Plug,Plastic

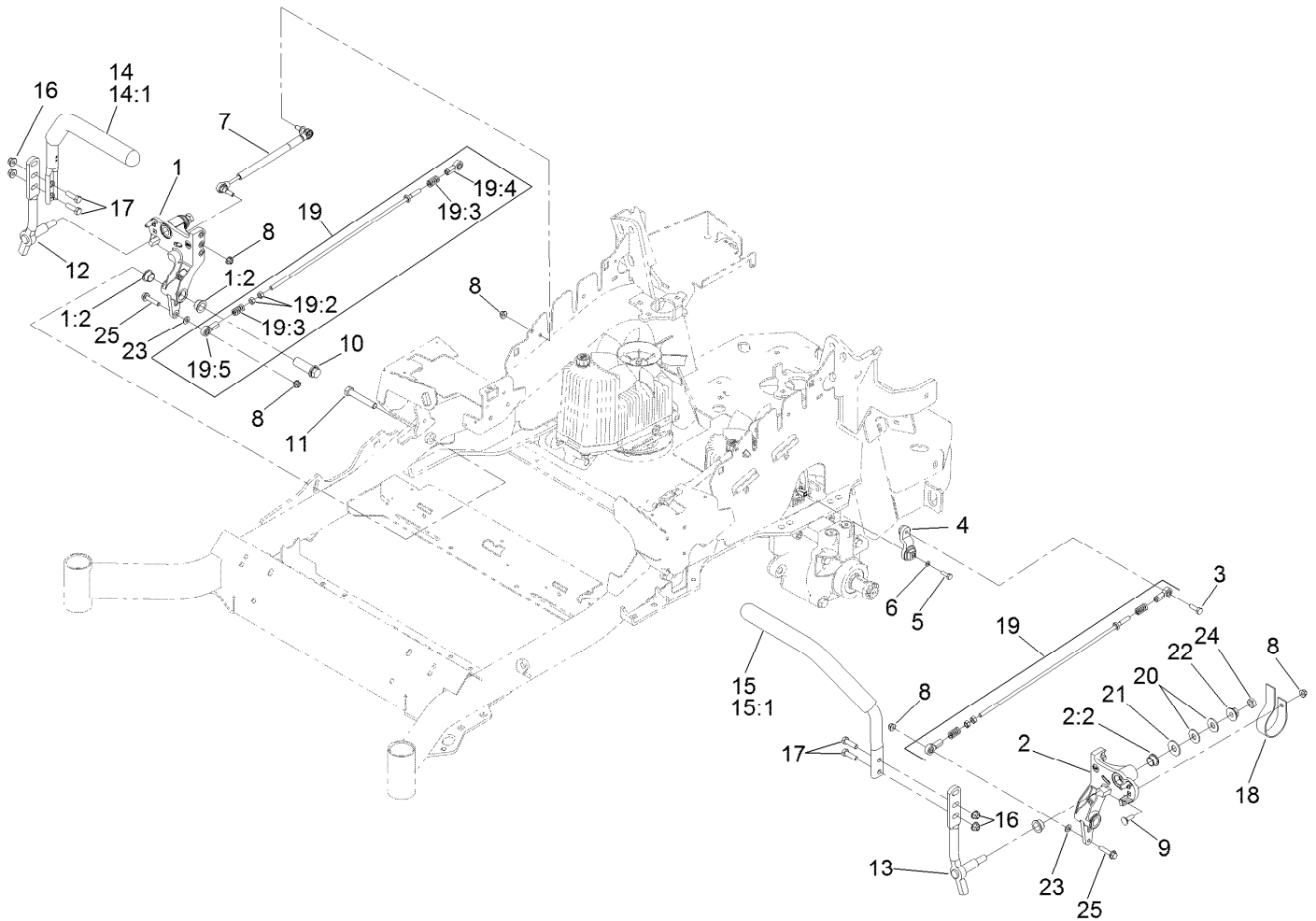

Motion Control Assembly

Ref.	Part Number	Qty.	Description	Ref.	Part Number	Qty.	Description
1	116-0880	1	RH Motion Control And Bushing ASM	14	109-6589	1	RH Steering Handle ASM
1:2	109-8054	4	Bushing-Flange	14:1	109-5668	1	Grip-Control, Lever
2	116-0881	1	LH Motion Control And Bushing ASM	15	109-6590	1	LH Steering Handle ASM
2:2	109-8054	4	Bushing-Flange	15:1	109-5668	1	Grip-Control, Lever
3	116-0648	2	Screw-HH, Thread Locking ●	16	104-8301	4	Nut-Flange, NI
4	109-4581	2	Arm-Control, Pump	17	323-7	4	Screw-HH
5	9080046	2	Screw-HH ●	18	109-5575	2	Spring-Leaf
6	1-303435	2	Washer-Spring	19	109-8106	2	Front Pump Linkage ASM
7	116-0027	2	Damper-Control, Motion	19:2	3219-2	2	Nut-Hex
8	104-8300	8	Nut-Flange, NI	19:3	1-323245	2	Spring-Compression
9	3230-2	2	Bolt-CARR	19:4	1-633152	1	Balljoint-LH
10	109-5891	2	Hub-Threaded	19:5	1-543017	1	Balljoint-RH
11	325-12	2	Screw-HH	20	109-9505	4	Washer-Spring
12	116-0039	1	Lever-Control Motion, RH	21	3256-6	2	Washer-Flat
13	116-0040	1	Lever-Control Motion, LH	22	32128-56	2	Nut-HF
				23	3256-23	2	Washer-Flat
				24	3218-5	2	Nut-Jam
				25	115-1794	2	Screw-HHF

● Use Pro-Lock, Nut Type (P/N 1-840022, .5ml tube) on threads.

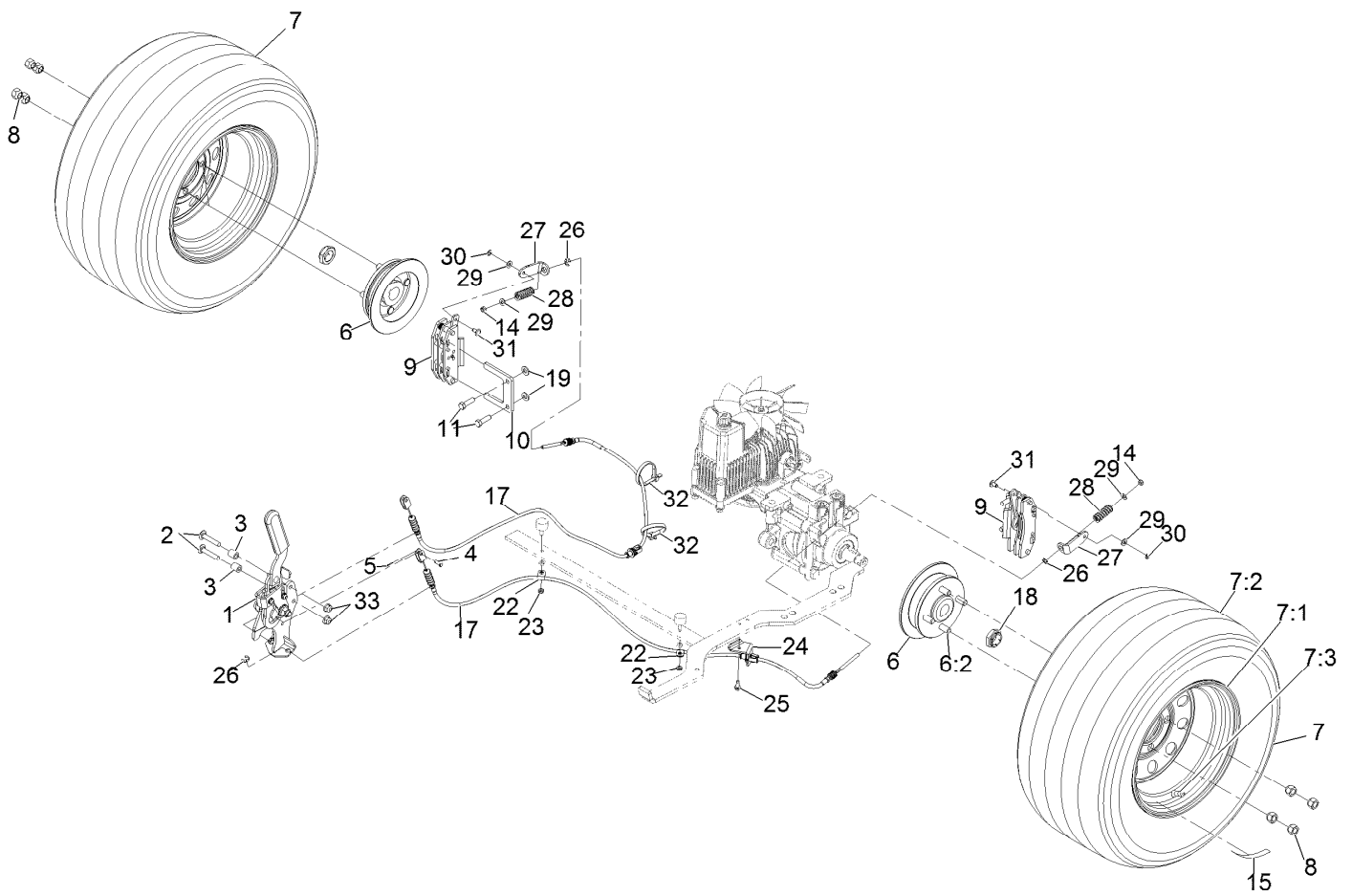

Rear Wheel and Park Brake Assembly

Ref.	Part Number	Qty.	Description	Ref.	Part Number	Qty.	Description
1	116-7551	1	Brake Handle ASM	14	3296-13	2	Nut-Nyloc 1/4-28
2	116-0629	2	Screw-Carriage 5/16-18 X 1 3/4 Short	15	116-2643	2	Decal-Wheel Nut Torque
3	82-6840	2	Spacer	17	116-8963	2	Cable, Brake
4	60-1730	2	Pin-Clevis	18	116-1399	2	Locknut
5	3272-1	2	Pin-Cotter 1/16 X 1/2	19	3256-24	4	Washer-3/8 Sae
6	116-1746	2	Wheel Hub ASM	22	88-7970	2	Clip
6:2	116-1696	4	Stud-Wheel	23	3296-56	2	Nut-Nyloc 1/4-20 Thin
7	109-8972	2	Wheel And Tire ASM	24	116-6397	1	Bracket-Cable
7:1	1-633993	1	Tire	25	32144-10	1	Screw-HWH 1/4-20 X .62
7:2	109-3156	1	Rim	26	32120-18	4	E-Ring
7:3	232-27	1	Stem-Valve	27	116-6182	2	Bracket-Brake, L
8	242-50	8	Nut-Lug 1/2-20	28	116-6347	2	Spring-Die
9	109-2889	2	Caliper-Brake	29	3256-22	4	Washer-1/4 Sae
10	109-0958	2	Plate-Mount, Brake	30	32151-86	2	E-Ring
11	92-5727	4	Screw-HH 3/8-16 X 1 1/4 Patch Lock	31	116-6348	2	Pin-Brake
				32	3334-945	2	Tie-Cable
				33	104-8300	2	Nut-Nyloc 5/16-18 Flg

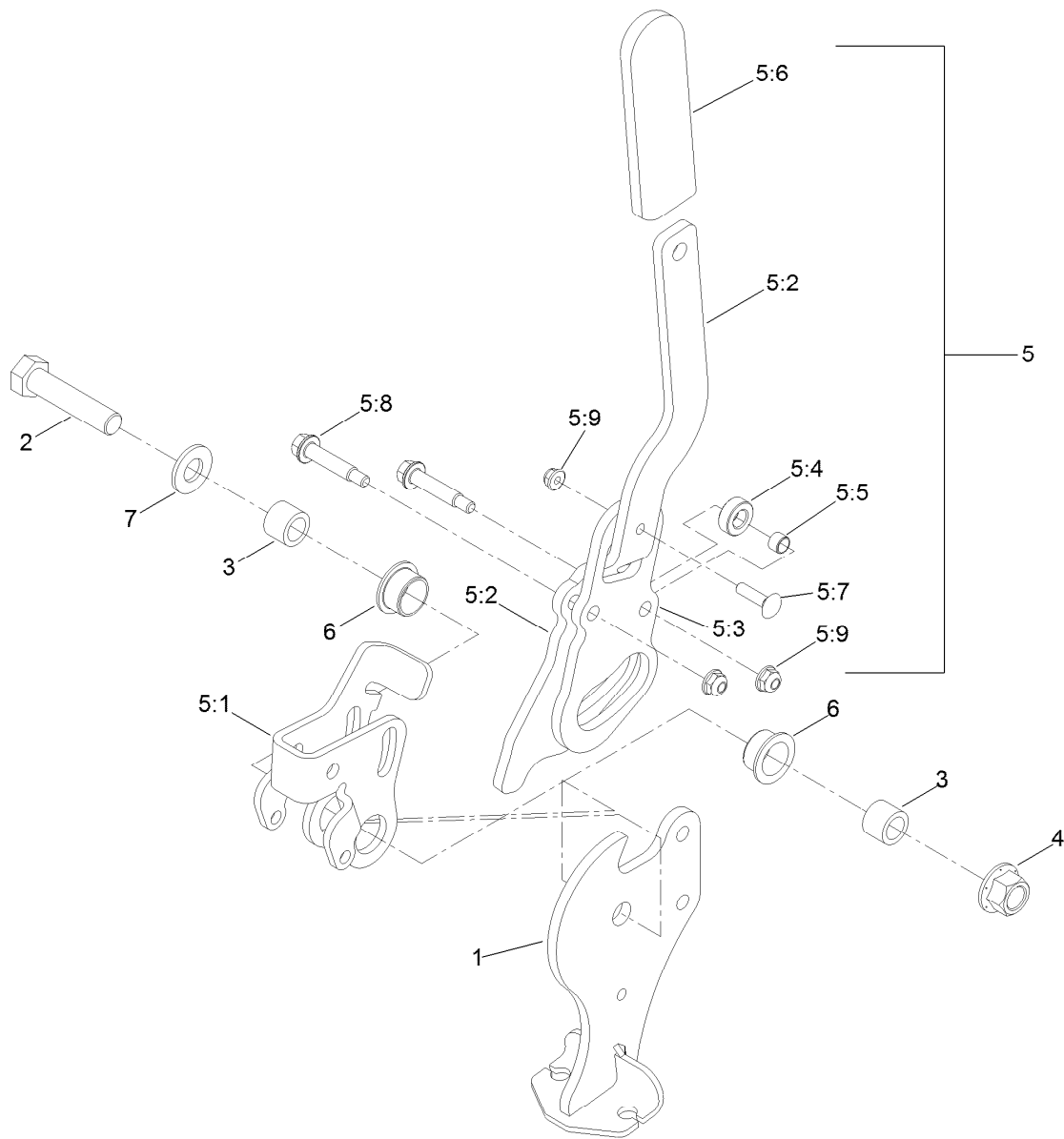

Parking Brake Handle Assembly No. 116-7551

<i>Ref.</i>	<i>Part Number</i>	<i>Qty.</i>	<i>Description</i>	<i>Ref.</i>	<i>Part Number</i>	<i>Qty.</i>	<i>Description</i>
1	116-7263	1	Pivot-Brake	5:4	116-6846	1	Roller-Brake
2	325-9	1	Screw-HH	5:5	116-6852	1	Bearing-Sleeve
3	116-5384	2	Spacer	5:6	1-633268	1	Grip-Lever
4	99-5107	1	Nut-Lock	5:7	3229-2	1	Screw-CARR
5	116-6860	1	Handle ASM	5:8	116-6876	2	Screw-Shoulder
5:1	116-6856	1	Bellcrank-Brake	5:9	104-7201	3	Nut-HF
5:2	116-6857	1	Handle-Brake	6	109-8054	2	Bushing-Flange
5:3	116-6858	1	Plate-Handle	7	3256-26	1	Washer-Flat

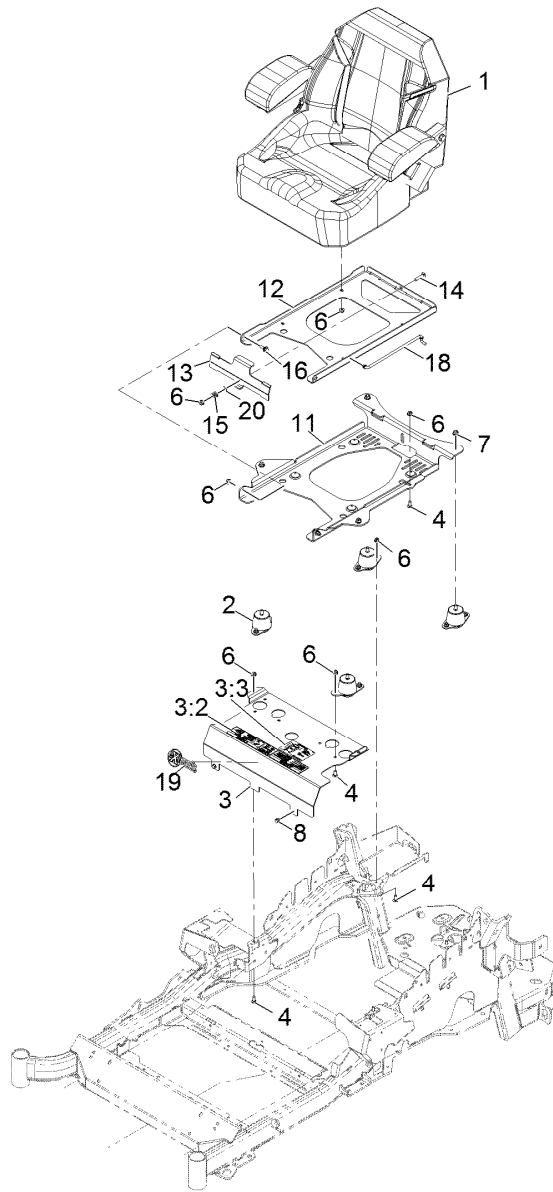

Seat Assembly

<i>Ref.</i>	<i>Part Number</i>	<i>Qty.</i>	<i>Description</i>	<i>Ref.</i>	<i>Part Number</i>	<i>Qty.</i>	<i>Description</i>
1	116-4474	1	Seat,Exmark Standard Service	11	116-3860-03	1	Plate-Tilt, Seat Support
2	109-9034	4	Isolator-Seat	12	116-3859-03	1	Plate-Seat, Frame
3	116-3327	1	Mount-Seat	13	109-9881-03	1	Plate-Latch, Seat
3:2	109-7069	1	Decal-Console	14	3230-4	1	Bolt-Carriage 5/16-18 X 1 1/2
3:3	116-0211	1	Decal-Service Aid	15	107-3017	1	Spring-Compression
4	3230-23	11	Bolt-Carriage 5/16-18 X 3/4 Short Neck	16	116-1297	2	Screw-Shoulder
6	104-8300	18	Nut-Nyloc 5/16-18 Flg	18	116-0070	1	Rod-Prop
7	104-8301	4	Nut-Nyloc 3/8-16 Flg	19	103-2883	1	Decal, Exmark Logo
8	9266934	2	Screw-HWH 5/16 X 1/2 Tf	20	3256-23	1	Washer-5/16 Sae

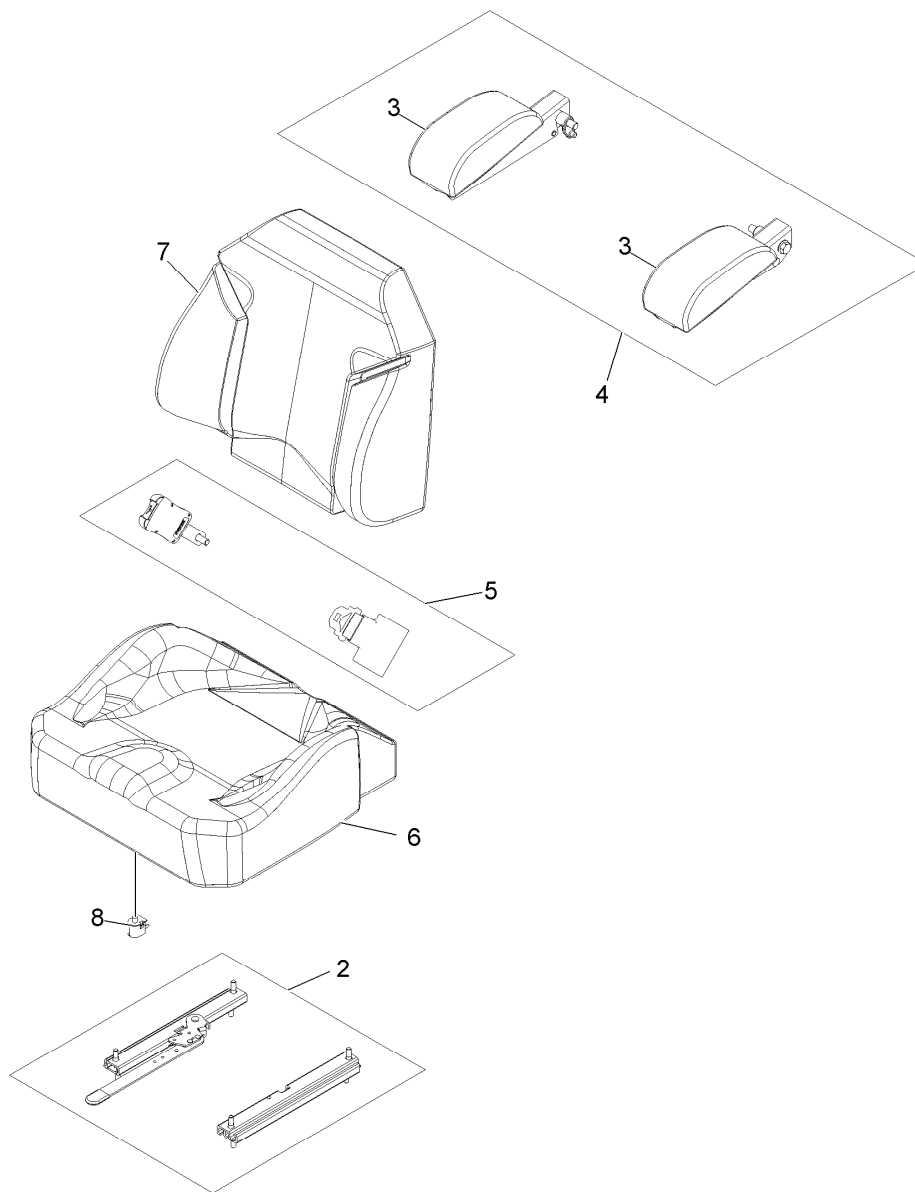

Seat W/Tracks Assembly No. 116-4474

<i>Ref.</i>	<i>Part Number</i>	<i>Qty.</i>	<i>Description</i>
2	109-9801	1	Seat Track Set
3	109-9802	1	Arm Rest Pad Set
4	109-9803	1	Arm Rest Set
5	109-9805	1	Seat Belt Kit
6	116-4925	1	Cover,Cushion
7	116-4926	1	Cover,Back
8	82-2190	1	Switch

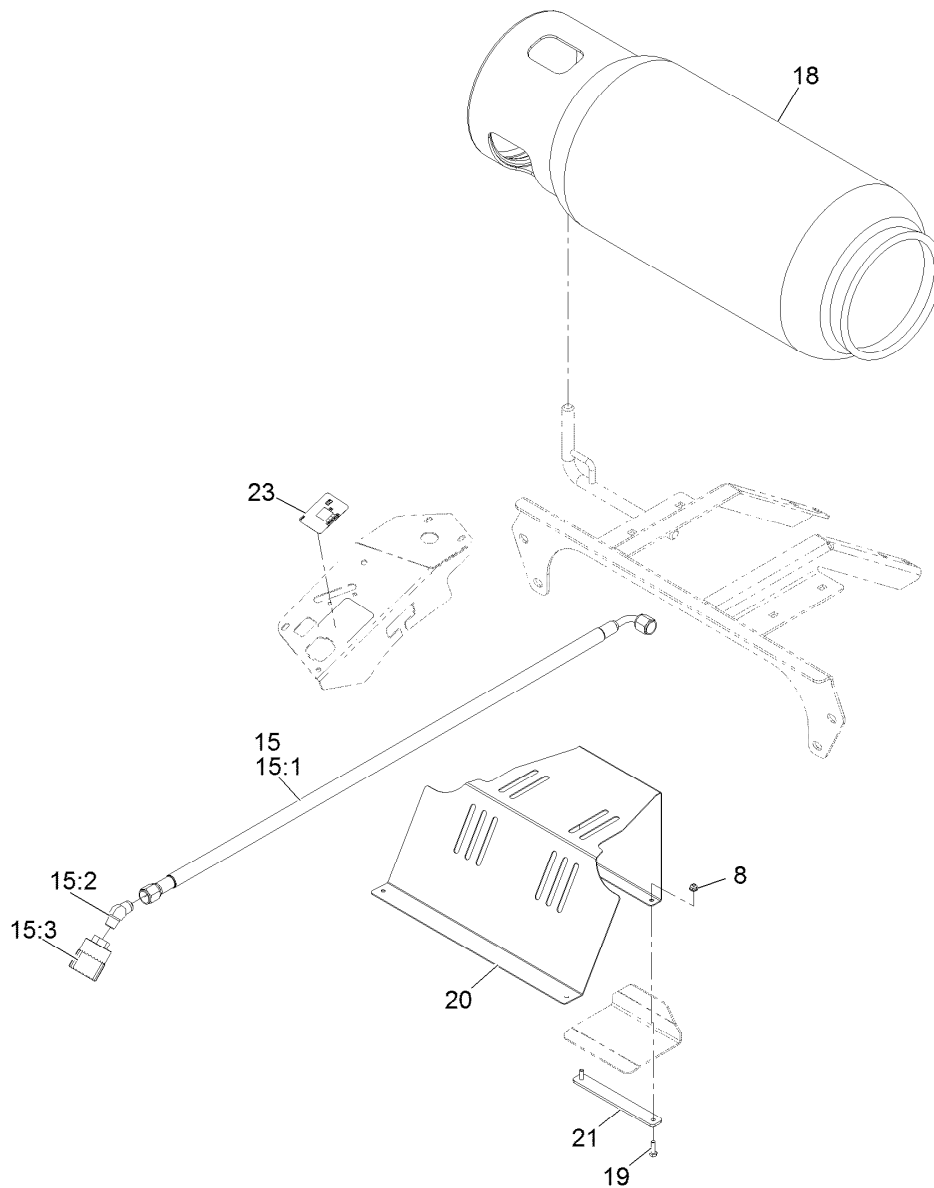

Fuel Assembly

<i>Ref.</i>	<i>Part Number</i>	<i>Qty.</i>	<i>Description</i>
8	104-7201	4	Nut-HF
15		1	Asm-LPG Hose ●
15:1	116-9312	1	LPG Fuel Hose ASM
15:2	116-1055	1	Elbow-45 DEG
15:3	116-1073	1	Connector-LPG Tank, LH Thread
18	116-1694	1	Tank-LPG
19	321-5	4	Screw-HH
20	116-3358-03	1	Shield-Fan
21	116-3359-03	1	Strap
23	116-3446	1	Decal-Hour Meter

● Not serviced separately

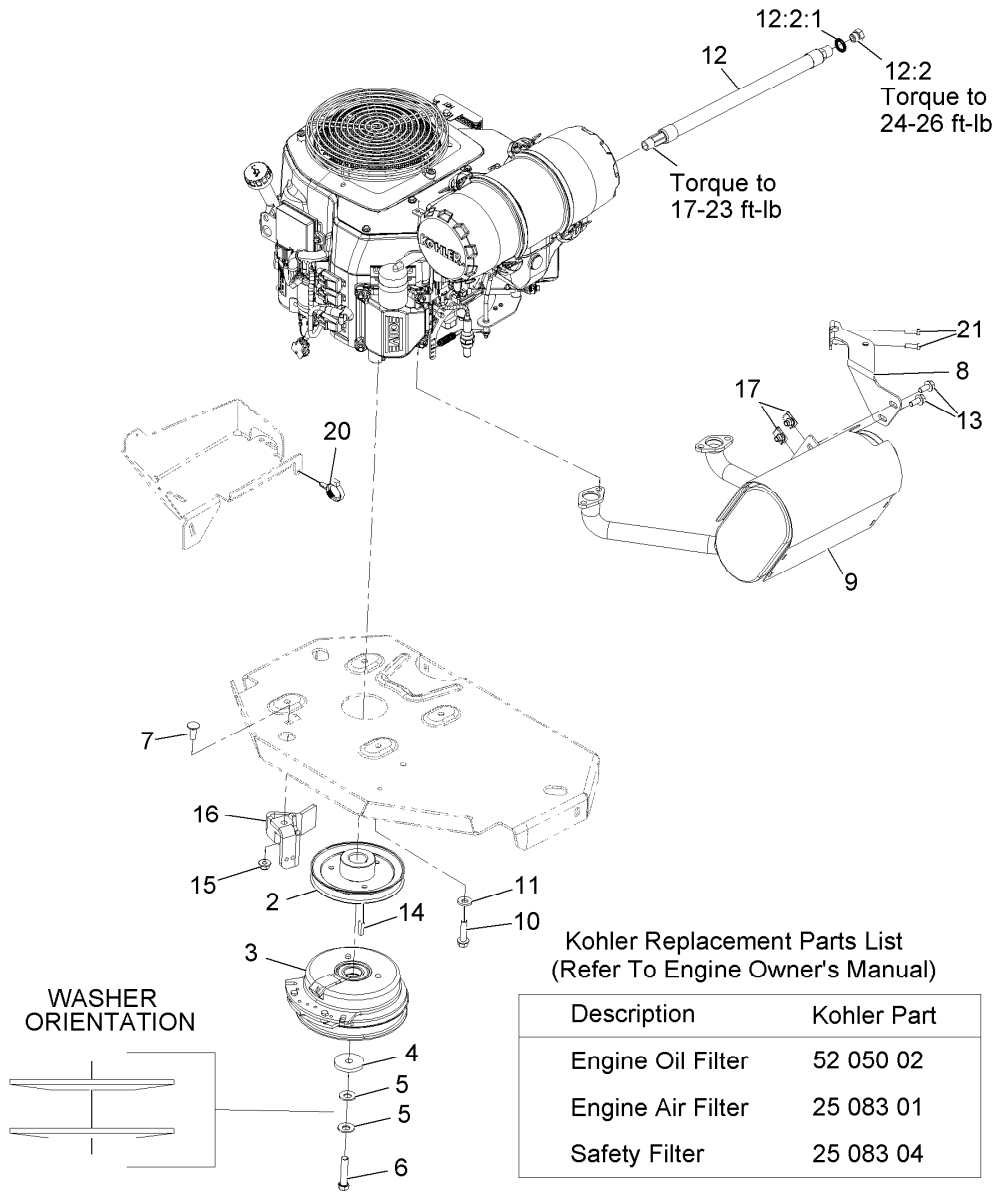

Engine Assembly

Ref.	Part Number	Qty.	Description
2	109-9905	1	Sheave
3	116-1620	1	Clutch Kit
4	109-6919	1	Washer-Clutch
5	1-603610	2	Washer-Spring Disc 7/16
6	109-9762	1	Screw-HH 7/16-20 X 2 W/Loctite ●
7	3231-22	1	Bolt-Carriage 3/8-16 X 1
8	116-4297	1	Muffler Bracket Kit
9	116-2038	1	Muffler
10	32144-102	4	Screw-HWH 3/8-16 X 1 1/2 Taptite
11	98-5975	4	Washer-Spring Disc 3/8

Ref.	Part Number	Qty.	Description
12	116-5316	1	Oil Drain Hose ASM
12:2	353-508	1	Plug-W/O-Ring
12:2:1	237-42	1	O-Ring
13	3234-5	3	Screw-HH Flg 5/16-18 X 3/4
14	1-807259	1	Key-Machine 1/4 X 1/4 X 1
15	104-8301	1	Nut-Nyloc 3/8-16 Flg
16	116-2612-01	1	Clutch-Anchor
17	94-2413	3	U-Nut
20	104-2490	1	Clamp-Hose
21	116-4295	2	Screw-HH M6-1 X 20Mm W/Patch

● Use Pro-Lock, Nut Type (P/N 1-840022, .5ml tube) on threads.

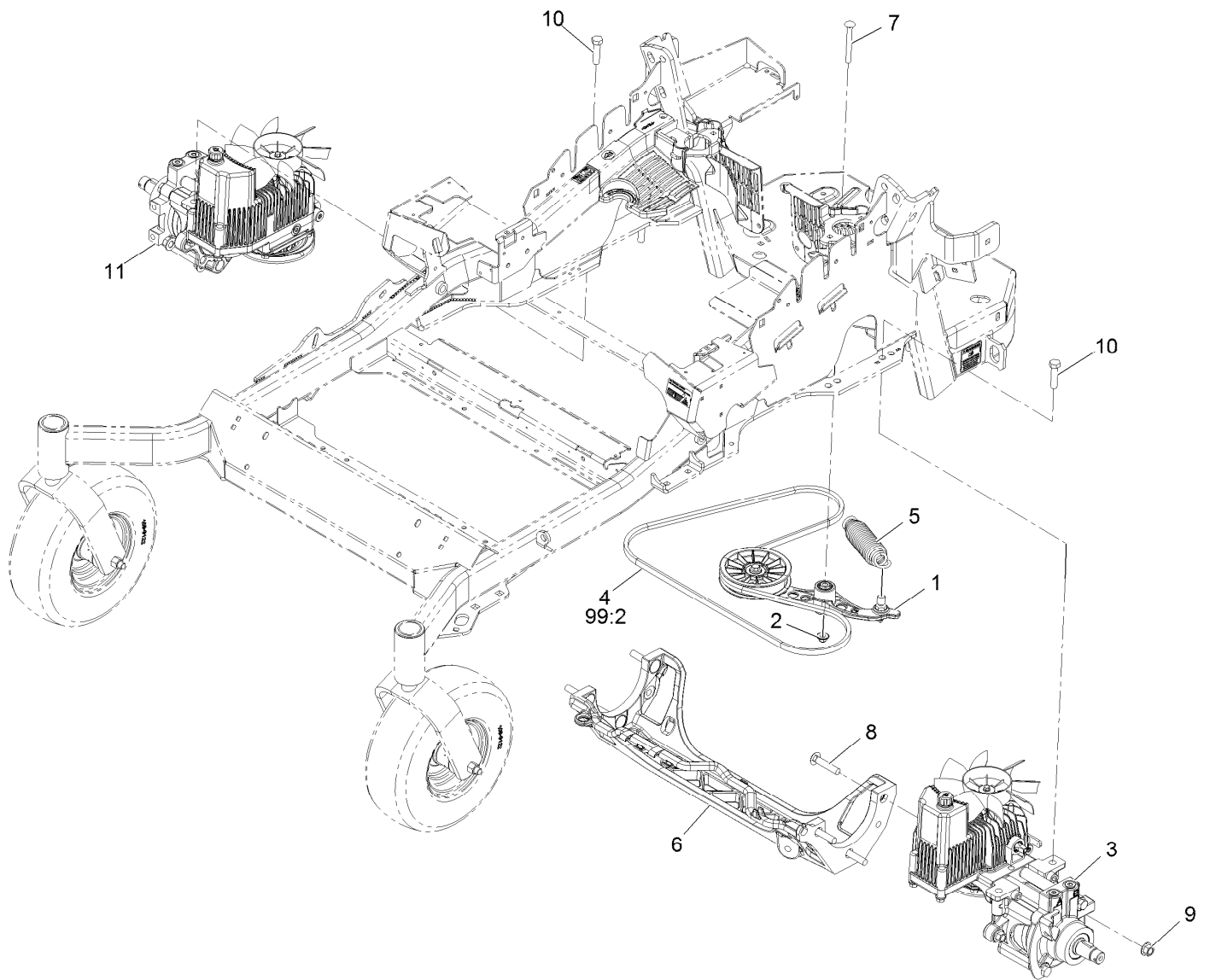

Hydraulic Assembly

Ref.	Part Number	Qty.	Description	Ref.	Part Number	Qty.	Description
1	116-1255	1	Pump Idler ASM	10	325-8	4	Screw-HH 1/2-13 X 1 1/4
2	109-6658	1	Nut-Nyloc 3/8-16 Flg	11	116-6414	1	RH Hydro ASM (12Cc W/Shock)
3	116-6413	1	LH Hydro ASM (12Cc W/Shock)	99	109-9828	1	Bottle-Oil, 32Oz Hydraulic ●
4	109-3388	1	Belt	99	116-0164	1	Filter-Hydro ●
5	116-6317	1	Spring-Extension	99	116-1218	1	Bottle,Oil 1 Gallon Hydraulic ●
6	109-9375	1	Cradle-Hydro	99	116-3270	1	Kit, Hydro Service ●
7	116-1502	1	Bolt-Carriage Shoulder 3/8-16 X 3 1/2	99:1	109-9828	4	Bottle-Oil, 32Oz Hydraulic ●
8	3233-34	6	Bolt-Carriage 1/2-13 X 2 1/2	99:2	109-3388	1	Belt
9	99-5107	6	Nut-Lock 1/2-13	99:3	116-0164	2	Filter-Hydro ●

● Not illustrated

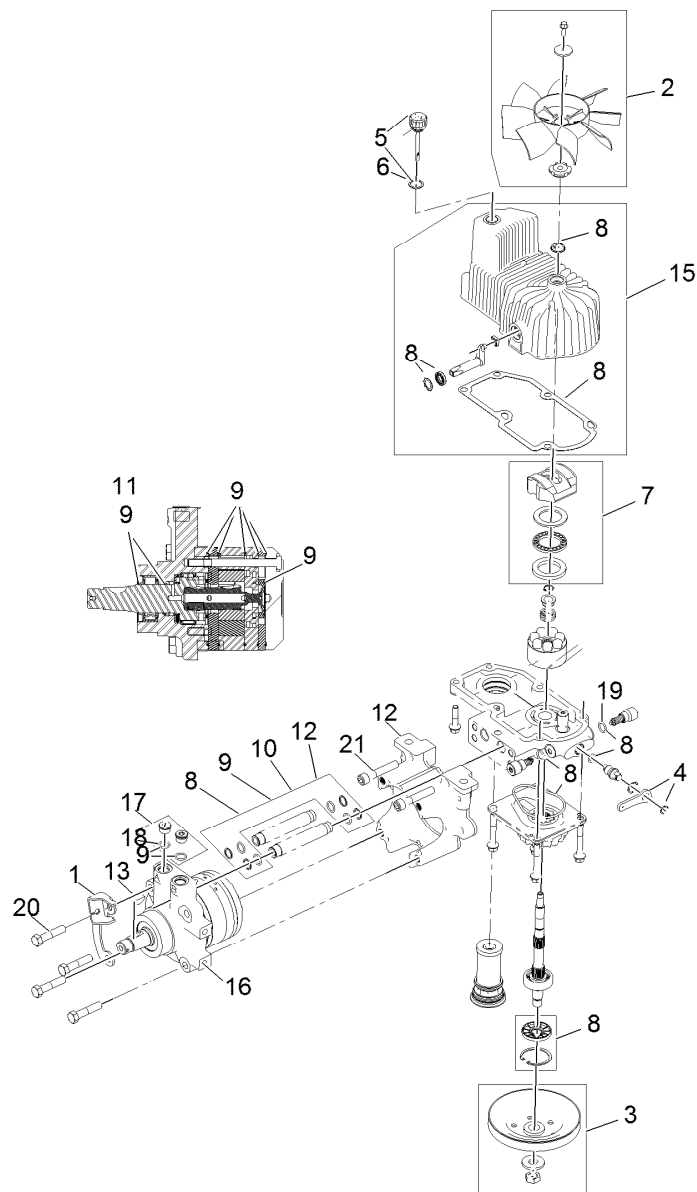

LH Hydro Assembly No. 116-6413

Ref.	Part Number	Qty.	Description	Ref.	Part Number	Qty.	Description
1	116-6859	1	Bracket-Anchor, Cable	11	116-1371	1	Output Shaft Seal Kit
2	116-0233	1	Fan Kit	12	116-5469	1	Nose Cup-Uht
3	116-0234	1	Pulley Kit	13	3257-42	1	Key-Woodruff 5/16 X 1
4	116-0235	1	Handle-Bypass Valve, Hydro	15	116-3287	1	Housing-LH
5	116-0236	1	Dipstick-Hydro W/Gasket	16	116-8915	1	Motor-Hydraulic LH 240Cc
6	116-0237	1	Gasket-Dipstick, Hydro	17	116-7901	1	Magnetic Plugs Service Kit
7	116-1367	1	Swash Block Kit	18	76-1900	2	O-Ring
8	116-1368	1	Pump Seal Kit	19	116-8662	2	O-Ring-Check Valve
9	116-1369	1	Motor Seal Kit	20	116-8974	4	Screw-HH 1/2-20 X 2 1/4
10	116-1370	1	Tube Seal Kit	21	116-8975	2	Screw-HSH 1/2-20 X 2 3/4
				99	116-1373	1	Flow Test Kit ●

● Not illustrated

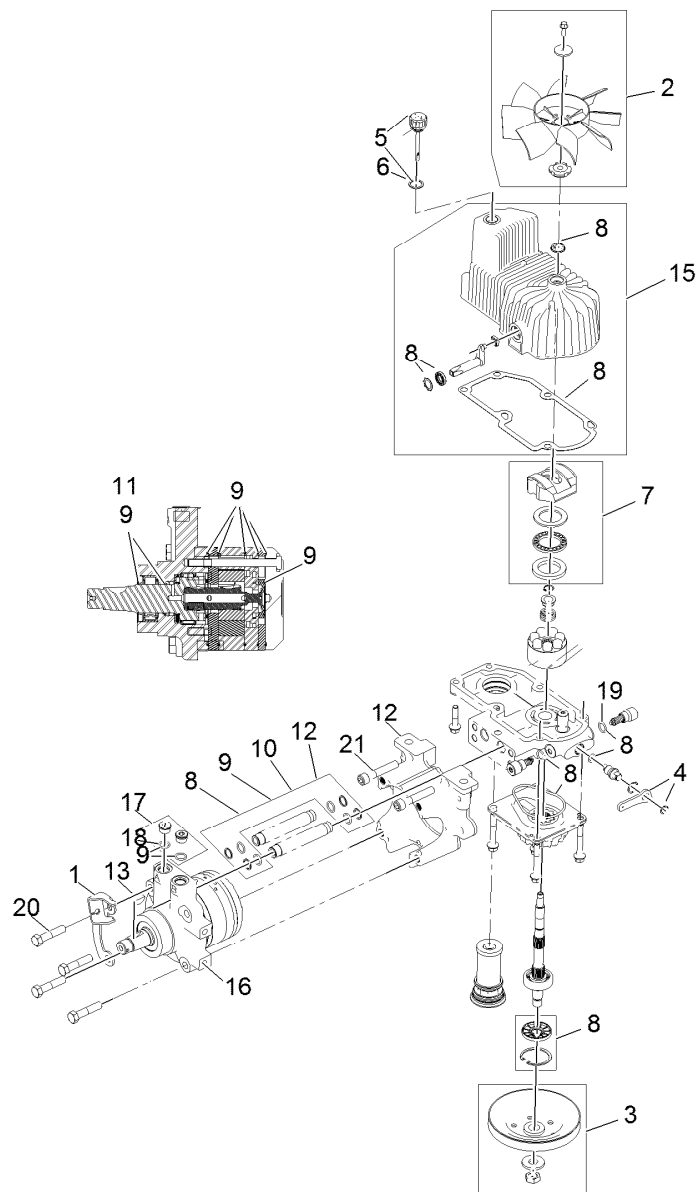

RH Hydro Assembly No. 116-6414

Ref.	Part Number	Qty.	Description	Ref.	Part Number	Qty.	Description
1	116-6859	1	Bracket-Anchor, Cable	11	116-1371	1	Output Shaft Seal Kit
2	116-0233	1	Fan Kit	12	116-5469	1	Nose Cup-Uht
3	116-0234	1	Pulley Kit	13	3257-42	1	Key-Woodruff 5/16 X 1
4	116-0235	1	Handle-Bypass Valve, Hydro	15	116-3288	1	Housing-RH
5	116-0236	1	Dipstick-Hydro W/Gasket	16	116-8916	1	Motor-Hydraulic RH 240Cc
6	116-0237	1	Gasket-Dipstick, Hydro	17	116-7901	1	Magnetic Plugs Service Kit
7	116-1367	1	Swash Block Kit	18	76-1900	2	O-Ring
8	116-1368	1	Pump Seal Kit	19	116-8662	2	O-Ring-Check Valve
9	116-1369	1	Motor Seal Kit	20	116-8974	4	Screw-HH 1/2-20 X 2 1/4
10	116-1370	1	Tube Seal Kit	21	116-8975	2	Screw-HSH 1/2-20 X 2 3/4
				99	116-1373	1	Flow Test Kit ●

● Not illustrated



Pump Idler Assembly No. 116-1255

Ref.	Part Number	Qty.	Description
2	43-0940	1	Spacer
3	103-3504	2	Bearing-Spherical
4	103-3505	1	Seal-Double Lip
5	103-3506	1	Seal-Single Lip
6	109-6658	1	Nut-Flange, NI
7	106-7159	2	O-Ring
8	323-8	1	Screw-HH
9	32120-10	2	Ring-Snap
10	302-19	1	Fitting-Grease
11	109-8076	1	Pulley-Idler
12	116-3467	1	Pin-Spring, Anchor

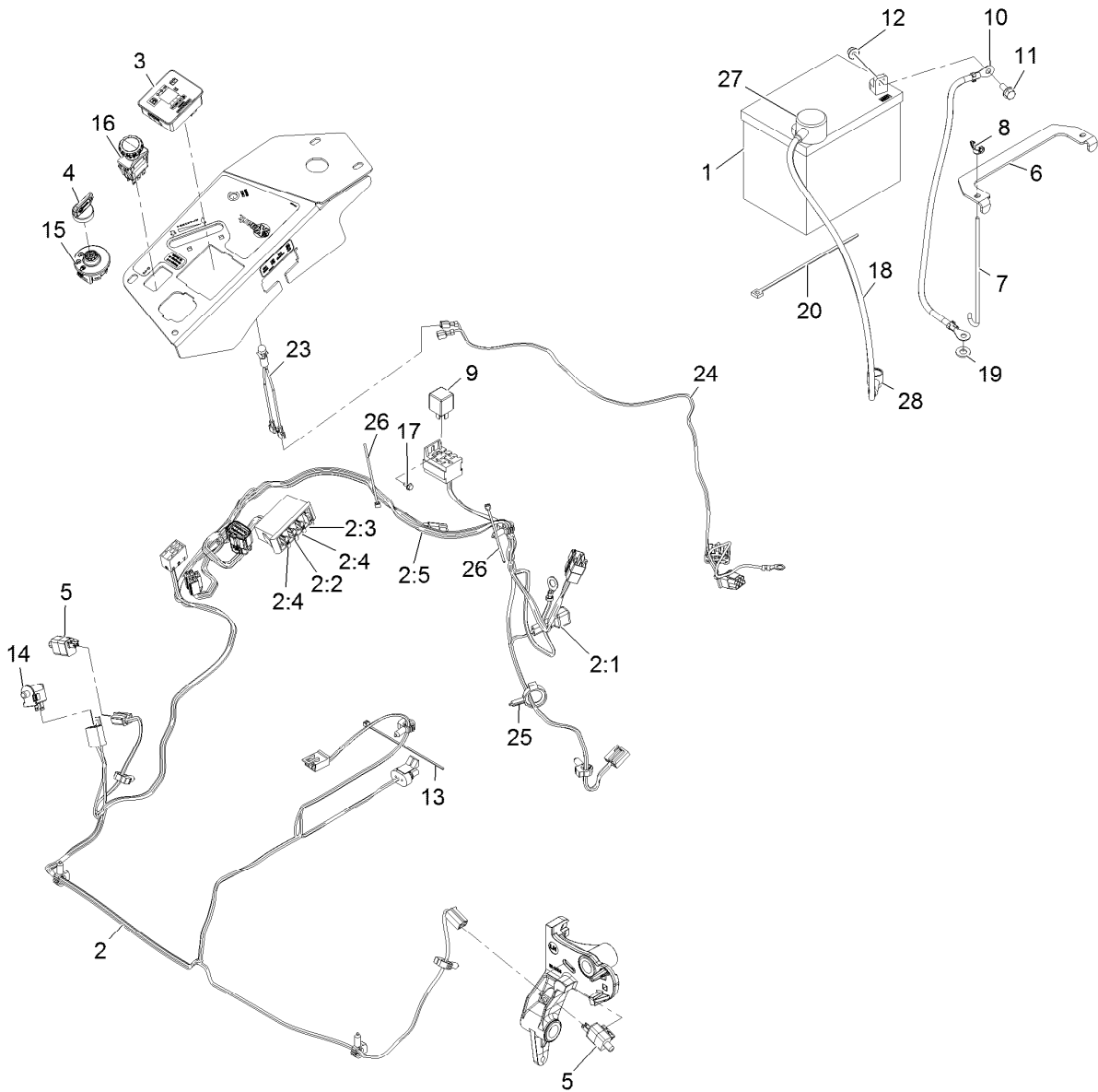

Electrical Assembly

Ref.	Part Number	Qty.	Description	Ref.	Part Number	Qty.	Description
1		1	Battery ●■	11	3234-5	2	Screw-HH Flg 5/16-18 X 3/4
2	116-6009	1	Harness-Wire, Main ▲	12	104-8300	2	Nut-Nyloc 5/16-18 Flg
2:1	103-3895	1	Diode-Tvs	13	1-303287	3	Tie-Cable 5 1/2 (Small)
2:2	218-578	1	Fuse-Blade, 10 Amp	14	82-2190	1	Switch
2:3	109355	1	Fuse-Blade, 15 Amp	15	117-2221	1	Switch-Ignition
2:4	109102	2	Fuse-Blade, 25 Amp	16	116-0124	1	Switch-PTO, 10A
2:5	116-0053	1	Cap-Plug	17	104-2065	1	Screw-HWH #10-24 X 3/8
3	117-3882	1	Fuel/Hour Meter ASM	18	115-3864	1	Cable-Battery, Positive
4	1-603511	1	Key-Ignition	19	3256-24	1	Washer-3/8 Sae
4	103-2106	1	Key-Exmark Logo	20	1-303335	1	Tie-Cable 7 15/16 (Large)
5	110-6765	2	Switch-Single Pole No	23	1-643267	1	Indicator-Red Led
6	116-0042-03	1	Strap-Tie Down, Battery	24	116-3062	1	Harness-Indicator Light
7	1-633651	2	Bolt-Holddown	25	105-1853	1	Clamp-Hose
8	1-543792	2	Wingnut-Nyloc 1/4-20	26	1-303287	2	Tie-Cable 5 1/2 (Small)
9	1-643275	1	Relay-12Vdc 40 Amp	27	109-2407	1	Insulator-Battery
10	114-1218	1	Cable-Battery, Negative	28	1-543393	1	Insulator-Solenoid

● Obtain locally.

■ Not serviced separately

▲ Use dielectric grease on all unsealed connectors and terminals only. Do not apply in sealed connectors.

EXMARK® MAINTENANCE

MAXIMIZE THE PERFORMANCE OF YOUR EXMARK.

4-CYCLE PREMIUM ENGINE OIL

Part No. 116-3373

Both SAE 30 and SAE 10W-30 in one bottle.

Contains increased levels of zinc and phosphorus for better lubricity.

No Viscosity Index Improvers that tend to shear down in high heat.

Synthetic formulation.

Gas & Diesel compatible.

Anti-corrosion additives.

API 'SL' and JASO rated with wet clutch compatibility for other machines.

PREMIUM HYDRO OIL

Part No. 109-9828

Commercial quality for tough, high-heat conditions.

Designed specifically for zero-turn mower hydraulic systems.

Superior shear resistance under heavy loads.

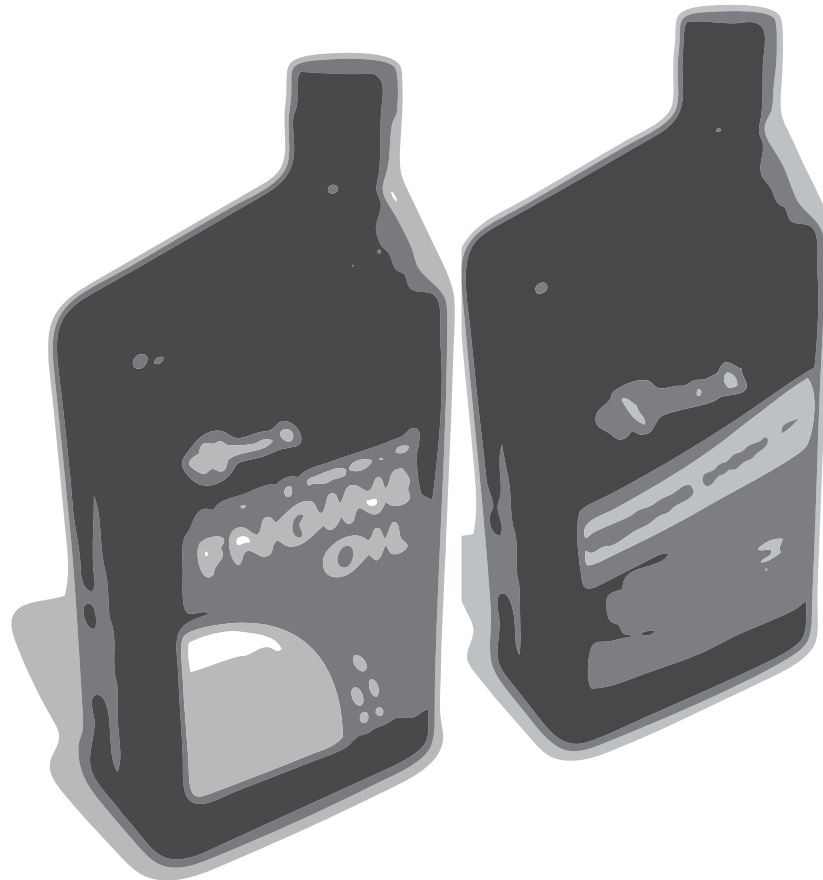

Available from your local Exmark dealer. Find your closest dealer at exmark.com

EXMARK ACCESSORIES AND OPTIONS*

MID-MOUNT RIDING ACCESSORIES AND OPTIONS

CUSTOM RIDE SEAT SUSPENSION SYSTEM	OPERATOR CONTROLLED DISCHARGE
FULL SUSPENSION SEAT	SUN SHADE
DECK LIFT ASSIST KIT	TRASH CONTAINER
HITCH KIT	TURF STRIPER
LIGHT KIT	ULTRA VAC COLLECTION SYSTEM
12V POWER PORT	ULTRA VAC QUICK DISPOSAL SYSTEM
MICRO-MULCH SYSTEM	

OUT-FRONT RIDING ACCESSORIES AND OPTIONS

CUSTOM RIDE SEAT SUSPENSION SYSTEM	SNOW BLADE
DUAL-TAIL WHEEL	SNOWBLOWER
FLOOR PAN EXTENDER	SUN SHADE
HITCH KIT	TRASH CONTAINER
LIGHT KIT	ULTRA VAC COLLECTION SYSTEM
MICRO-MULCH SYSTEM	ULTRA VAC QUICK DISPOSAL SYSTEM
ROLL OVER PROTECTION SYSTEM (ROPS)	WEATHER CAB

WALK-BEHIND ACCESSORIES AND OPTIONS

GRASS CATCHER	TURF STRIPER
MICRO-MULCH SYSTEM	STANDON

*Some accessories and options not available for some models.

Place Model No. and Serial No.
Label Here (Included in the Literature
Pack) or Fill in Below

Model No. _____

Serial No. _____

Date Purchased _____

Engine Model No. and Spec. No. _____

Engine Serial No. (E/No) _____

© 2013 Exmark Mfg. Co., Inc.
Industrial Park Box 808
Beatrice, NE 68310
All Rights Reserved

Part No. 4501-594 Rev. A
(402) 223-6300
Fax (402) 223-5489
Printed in the USA.

