

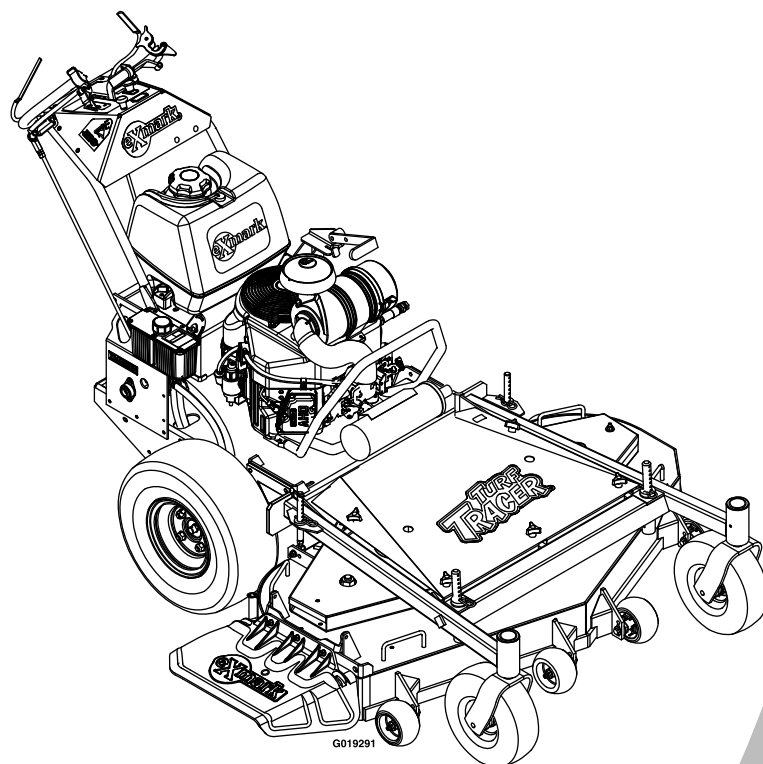

TURF TRACER® X-SERIES

Model No. TTX650EKCE524—Serial No. 31300000 and Up

Picture below may not reflect actual product.



Parts Manual

Part No. 4501-462 Rev. A

Ordering Replacement Parts

To order replacement parts, please supply the part number, the quantity, and the description of each part desired.

Understanding Reference Numbers

Each identified part in an illustration has a reference number. The reference number for a part also appears in the parts list, along with other information about the part.

This catalog uses two special reference number formats, one to indicate parts in a service assembly and another to indicate the quantity of a given part in an illustration.

Service Assembly Reference Numbers

Parts in service assemblies have reference numbers in the form a:b. The a represents the reference number of the entire service assembly and the b represents a sequential number unique to each part within the service assembly.

For example, a wheel assembly might be identified by reference number 6, the tire by 6:1, the valve by 6:2, and the wheel by 6:3. When you order the assembly identified by reference number 6, you receive all parts identified by reference numbers 6:1, 6:2, and 6:3. However, you may also order any part individually. Reference numbers of this type appear in illustration and in parts lists.

Reference Numbers Indicating Quantity

In an illustration, if a reference number indicates more than one part, the reference number has the form nX y. The n represents the quantity of the part, the X is the multiplication symbol, and the y represents the reference number.

For example, in an illustration, the reference number 2X 37 means that two of the parts identified by reference number 37 are indicated.

List of Abbreviations

AR: as required	HJ: hex jam	PRH: phillips round head
ASM: assembly	HLH: hex lag head	PTH: phillips truss head
BBC: blade brake control	HOC: height-of-cut	PTO: power-take-off
BHTF: button head thread forming	HSBH: hex socket button head	RH: right hand
CARR: carriage	HSFH: hex socket flat head	ROPS: roll-over protection system
CCW: counter clockwise	HSH: hex socket head	RRB: rear roller brush
CW: clockwise	HWH: hex washer head	SFH: slotted fillister head
DEG: degrees	HWHTF: hex washer head thread forming	SHH: slotted hex head
DPA: Dual Point Adjustment	HYD: hydraulic	SHWH: slotted hex washer head
ECM: electronic control module	LH: left hand	SPH: slotted pan head
EXT: external	LP: Liquefied Petroleum Gas	SQH: square head
FH: flat head	LPG: Liquefied Petroleum Gas	SRH: slotted round head
GA: gauge	NI: nylon insert	STD: standard
HD: heavy-duty	NPTF: national pipe thread fine	TAP: self tapping
HF: hex flange	PFH: phillips flat head	TTH: torx truss head
HH: hex head	PPH: phillips pan head	
HHF: hex head flange	PPHTF: phillips pan head thread forming	
HHFTF: hex head flange thread forming		

Touch Up Paint

Exmark black touch up spray paint – gloss black.

Exmark red touch up paint (spray paint – P/N 1-850337 - .6 oz liquid bottle – P/N 103-9140).



If your Exmark dealer does not have the Exmark part in stock, Exmark will get the parts to the dealer the next business day or the part will be FREE Guaranteed!! (Some restrictions apply. See your participating Exmark Dealer for details.)

Contents

Deck Assembly	4
Deck Support Assembly	6
ECS Upper Handles and Controls Assembly	8
Engine Deck Assembly	10
Park Brake and Engine Assembly	12
Fuel Tank Assembly	14
Hydraulics Assembly	15
Electrical Assembly	16
Decals	17

Deck Assembly (continued)

Ref.	Part Number	Qty.	Description	Ref.	Part Number	Qty.	Description
1	109-9220	3	Screw-Sems 1/2-20 X 2.19	40	322-2	5	Screw-HH 5/16-18 X 5/8
2	323-6	2	Screw-HH 3/8-16 X 1	41	1-303516	2	Pulley, V-Idler
3	98-5975	11	Washer-Spring Disc 3/8	42	32128-20	8	Nut-Whizlock 5/16-18
4	3290-357	17	Nut-Whizlock 3/8-16	43	1-806332	2	Rollpin 1/4 X 1 1/2
5	323-7	18	Screw-HH 3/8-16 X 1 1/4	44	1-411532	2	Kit, Support Link W/Pin
6	3217-46	3	Nut-Hex 3/4-16 Heavy	45	1-603413	1	Spring-Extension
7	103-2802	3	Washer-Spring Disc 3/4	46	109-4077	1	Pulley-Idler, Flat
8	103-2794	3	Sheave, Blade Drive ▲	47	3234-11	2	Screw-HH Flg 3/8-16 X 1
9	103-2535	3	Spacer-Guard Bottom	48	3296-39	20	Nut-Nyloc 3/8-16
10	103-9086	2	Kit-Splined Spindle ▲	49	103-2916	2	Guard-Top
11	109-4722	1	Asm, Discharge Chute	50	103-3506	2	Seal-Single Lip
12	103-9087	1	Kit, Center Blade Spindle (Long) ▲	51	103-8072	1	Kit, Idler Arm W/Bearings ●
13	103-2982	4	Key-Machine 1/4 X 3/16 X 3/4	52	32120-10	4	Ring-Retaining
14	103-2793	1	Sheave, Mower Drive ▲	53	103-8071	1	Kit, Idler Arm W/Bearings ●
15	103-1330	3	Guard-Bearing Top ▲	54	302-40	2	Zerk-90° 1/4-28
16	103-8280	3	Asm, Cutter Housing W/Bearings ▲	55	116-5947	1	Asm, Complete Deck
17	322-3	1	Screw-HH 5/16-18 X 3/4	56	1-413525	2	Link, Rear Deck Support
18	103-2969-01	2	Cover, Deck	57	1-613204	2	Balljoint
19	103-2329	1	Belt, Blade Drive	58	1-603299	6	Roller-Scalp, Anti
20	323-23	1	Screw-HH 3/8-16 X 4-1/2	59	103-4051	6	Kit, Antiscalp Roller (44" And 48")
21	103-9084	1	Housing, Cutter Complete (Center)	60	99-2842	6	Spacer
22	103-9076	2	Asm, Cutter Housing Complete	61	1-603620-01	1	Bracket, Spring Anchor
23	103-3209	1	Spacer, Tube	62	98-5961	2	Screw-HH 3/8-16 X 4 Gr8
24	1-413425	2	Spacer	63	1-603414	1	Spring-Extension
25	3256-82	3	Washer	64	116-2072-01	1	Baffle
26	323-9	2	Screw-HH 3/8-16 X 1 3/4	65	1-603001	2	Rod, Deck Support
27	1-603050	4	Spacer	66	3256-24	5	Washer-3/8 Sae
28	1-633988	1	Spacer-Anchor, Clutch	67	103-6402	3	Blade-Notched
29	1-800017	2	Bolt-HH 5/16-18 X 3 1/4 Tap	67	103-6382	3	Blade, Solid
30	1-513791	1	Bushing	67	103-6387	3	Blade, Low Lift
31	3256-3	6	Washer-5/16 Std	67	103-6392	3	Blade, Mulching ■
32	323-12	4	Screw-HH 3/8-16 X 2 1/2	67	103-6397	3	Blade, Extreme
33	3220-3	2	Nut-Jam 3/8-24	68	1-806009	4	Hairpin-Cotter #206
34	1-603805	1	Pulley-Idler	69	1-323539	2	Spacer-Blade Drive
35	1-613098	1	Pulley-Idler	70	103-3505	2	Seal, Double, Lip
36	116-5949	1	Deck, (116-5862-01) W/ Decals	71	103-3504	4	Bearing-Spherical
37	109-2738	1	Chute, Discharge	72	1-413088	2	Spacer
38	322-5	2	Screw-HH 5/16-18 X 1	73	106-7159	4	O-Ring
39	3296-29	8	Nut-Nyloc 5/16-18	74	109-6658	6	Nut-Nyloc 3/8-16 Flg
				75	103-3037	3	Bushing, Splined
				76	109-4573-01	1	Bracket, Discharge Chute
				77	3230-22	3	Bolt-Carriage 5/16-18 X 1 Sp

● Assembly also includes Washer and Screw

■ Requires installation of mulch kit for proper mulching. See your Exmark dealer for details.

▲ Apply Mobil HTS grease (P/N 103-5217 1.5 oz packet) (or a food-grade anti-seize). See operator s manual for locations.

Deck Support Assembly

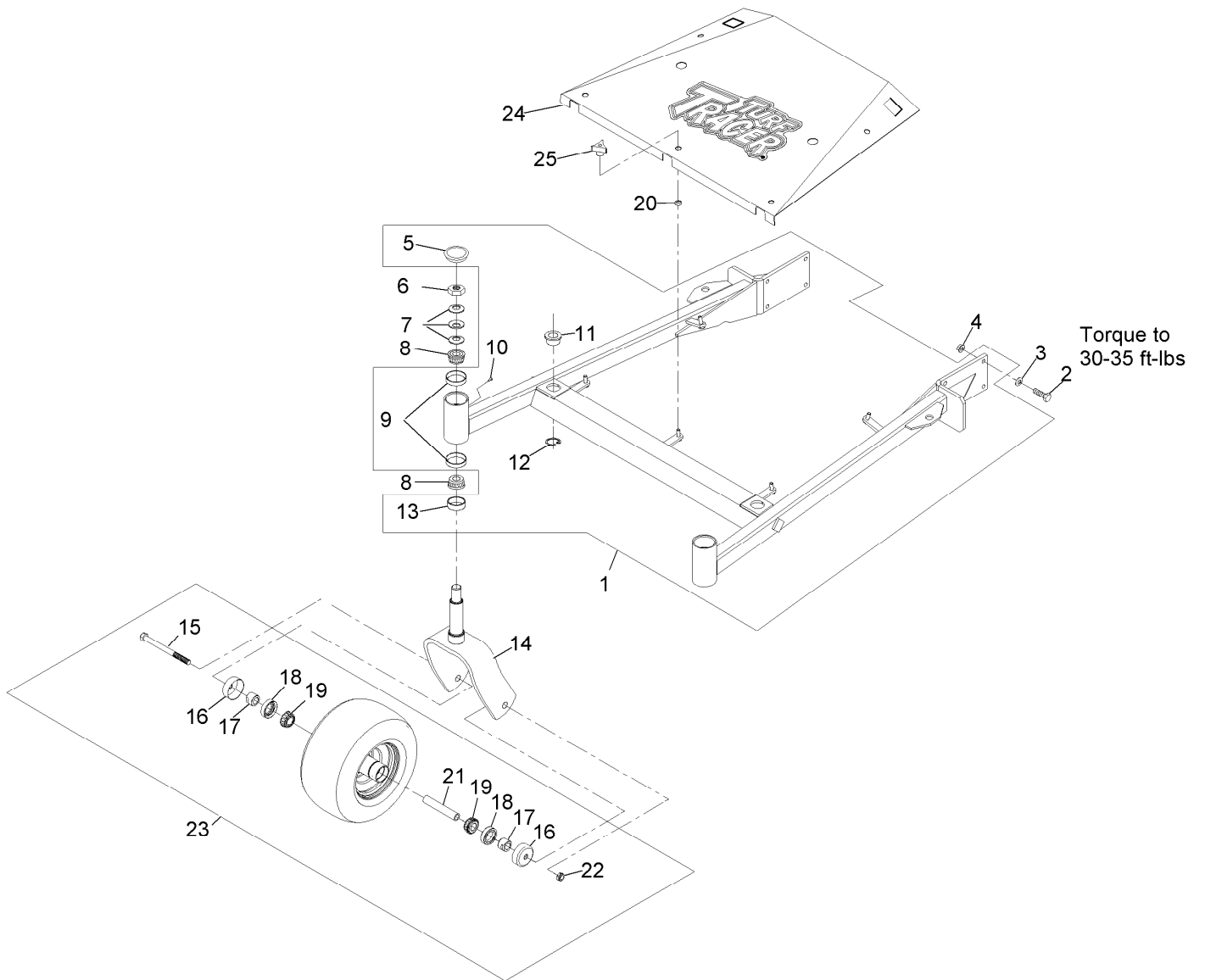

Deck Support Assembly (continued)

<i>Ref.</i>	<i>Part Number</i>	<i>Qty.</i>	<i>Description</i>	<i>Ref.</i>	<i>Part Number</i>	<i>Qty.</i>	<i>Description</i>
1	103-1895	1	Support, Deck 103-4959-01 W/Bsgs And Decals	14	103-1891-01	2	Wld, Caster Fork
2	323-7	8	Screw-HH 3/8-16 X 1 1/4	15	325-20	2	Screw-HH 1/2-13 X 6
3	98-5975	8	Washer-Spring Disc 3/8	16	103-2768	4	Guard-Seal
4	3290-357	8	Nut-Whizlock 3/8-16	17	103-3051	4	Spacer-Nut ●
5	103-4882	2	Cap-Grease	18	103-0063	4	Seal-Double Lip
6	3296-51	2	Nut-Nyloc 3/4-10	19	1-633585	4	Bearing-Cone Tapered Roller
7	1-633508	6	Washer-Spring Disc	20	1-323417	5	Washer-Belt Shield
8	1-543509	4	Cone-Bearing Tapered Roller	21	103-3157	2	Axle-Caster
9	1-543508	4	Cup-Bearing Tapered Roller	22	3296-45	2	Nut-Nyloc 1/2-13 Thin
10	1-811010	2	Plug	23	109-3524	2	Asm, Wheel And Bearings
11	1-513336	2	Bushing-Deck	24	116-2708	1	Shield, Belt (103-2319-01) W/Decal (52")
12	32120-33	2	Ring-Retaining	25	1-323385	5	Knob-3 Prong
13	1-543511	2	Seal-Grease				

● Use Pro-Lock, Nut Type (P/N 1-840022, .5ml tube) on threads.

ECS Upper Handles and Controls Assembly

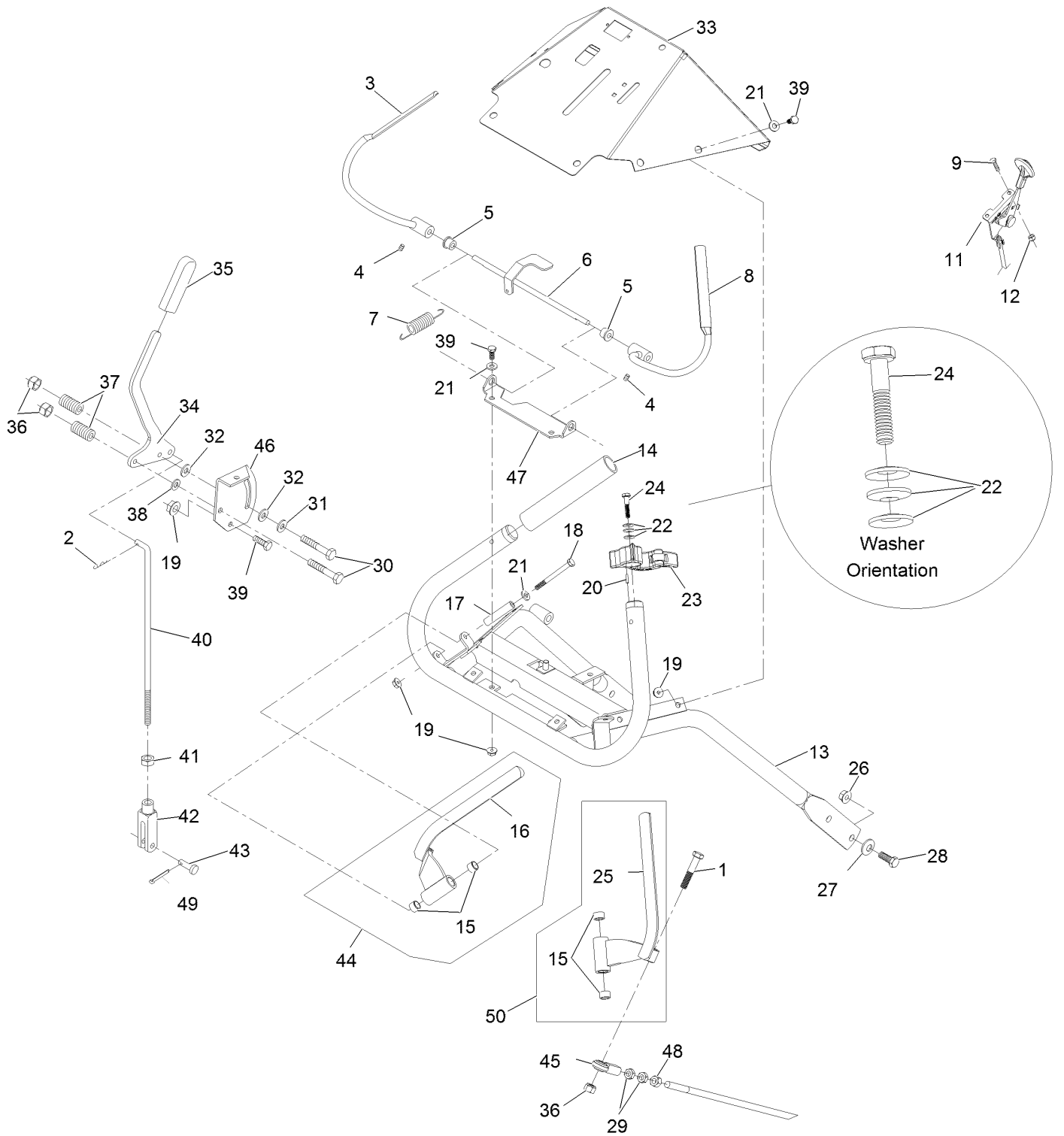

ECS Upper Handles and Controls Assembly (continued)

Ref.	Part Number	Qty.	Description	Ref.	Part Number	Qty.	Description
1	322-9	2	Screw-HH 5/16-18 X 1 3/4	25	116-4082	1	Lever, Drive RH
2	1-806003	1	Hairpin-Cotter	26	3290-357	4	Nut-Whizlock 3/8-16
3	116-4079	1	Wld, Lever, Opc (LH) ▲	27	98-5975	4	Washer-Spring Disc 3/8
4	1-803322	2	Setscrew-5/16-24 X 5/16 ■	28	323-6	4	Screw-HH 3/8-16 X 1
5	1-303365	2	Bushing-Nylon	29	3220-3	4	Nut-Jam 3/8-24
6	103-0769-03	1	Wld, Opc Axle Lever	30	322-10	2	Screw-HH 5/16-18 X 2
7	1-303363	1	Spring-Extension	31	1-603716	1	Washer-Friction Disc
8	116-4080	1	Wld, Opc Lever (RH) ▲	32	1-323244	2	Washer-Friction
9	1-807513	2	Bolt-Carriage #10-24 X 1/2	33	116-5094	1	Console 109-4506-03 W/ Decals
11	109-3958	1	Control-Throttle	34	116-8632	1	Lever-Shift W/Grip
12	3296-2	2	Nut-Nyloc #10-24	35	103-5994	1	Grip, Steering Handle
13	103-1537-03	1	Handle Weldmt, Upper Ecs	36	3296-29	4	Nut-Nyloc 5/16-18
14	103-0815	2	Grip-Bar, Handle	37	1-323245	2	Spring-Compression
15	1-413152	4	Bushing-Sleeve	38	3256-23	1	Washer-5/16 Sae
16	116-4081	1	Lever, Drive LH	39	321-3	10	Screw-HH 1/4-20 X 5/8
17	103-0027	2	Bushing-Lever, Drive	40	1-413225	1	Rod, Speed Control
18	321-14	2	Screw-HH 1/4-20 X 2 3/4	41	3220-2	1	Nut-Jam 5/16-24
19	32128-33	12	Nut-Whizlock 1/4-20	42	1-303105	1	Yoke-Adjustable
20	103-0464	2	Pin-Spring 1/8 X 1/2	43	1-808280	1	Pin-Clevis 5/16 X 1 49/64
21	3256-22	10	Washer-1/4 Sae	44	103-2514	1	Asm, Drive Lever LH
22	1-303435	6	Washer-Spring Disc 1/4	45	103-2463	2	Balljoint
23	103-1371	1	Thumb Latch Asm RH(Shown)	46	103-0503	1	Bracket, Shifter Slide
23	103-1372	1	Thumb Latch Asm LH(Not Shown) ●	47	103-0489-03	1	Bracket, Opc Axle
24	103-0235	2	Screw-HH 1/4-20 X 1 1/8 W/Nylon ■	48	3219-3	2	Nut-Hex 3/8-24
				49	3272-5	1	Pin-Cotter 3/32 X 1/2
				50	103-2513	1	Asm, Drive Lever RH

● Not illustrated

■ Use Pro-Lock, Nut Type (P/N 1-840022, .5ml tube) on threads.

▲ Use Pro-Lock retaining type, Part no. 1-840023 (.5cc tube) on inside of bore of OPC hub.

Engine Deck Assembly

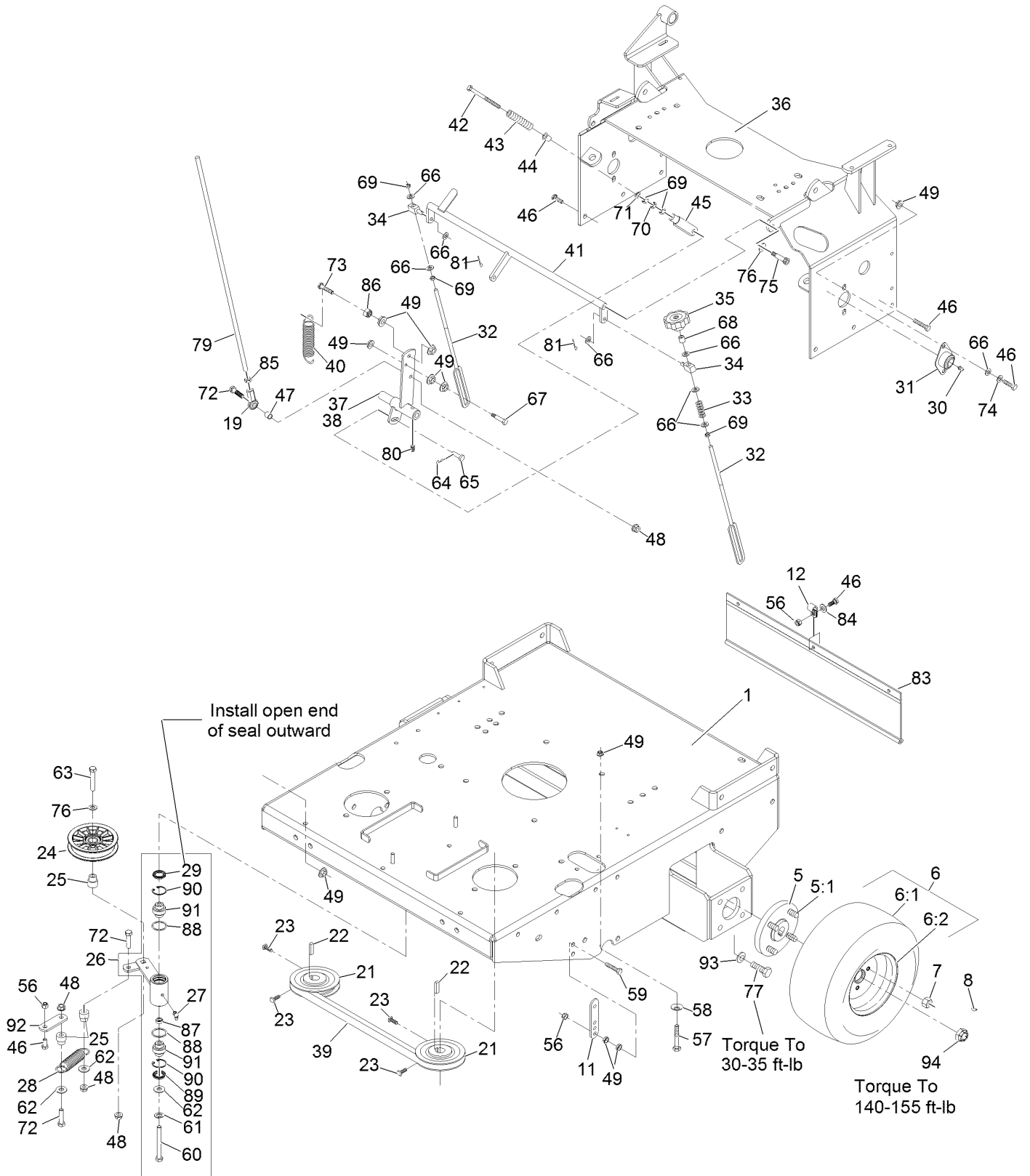

Engine Deck Assembly (continued)

Ref.	Part Number	Qty.	Description	Ref.	Part Number	Qty.	Description
1	116-6130	1	Eng Deck (116-8949-01) W/ Decals	49	32128-20	27	Nut-Whizlock 5/16-18
5	112-9049	2	Wheel Hub ASM	56	3296-29	6	Nut-Nyloc 5/16-18
5:1	1-633926	8	Stud-Wheel	57	322-7	4	Screw-HH 5/16-18 X 1 1/2
6	103-1715	2	Tire And Wheel Assy	58	1-303334	4	Washer-Spring Disc 5/16
6:1	103-2237	2	Tire	59	1-800016	2	Bolt-HH 5/16-18 X 1 1/4 Tap
6:2	103-2238	2	Wheel Only	60	1-800805	1	Screw-HH 3/8-16 X 3-1/2 Gr8 ■
7	242-50	8	Nut-Lug 1/2-20	61	3253-5	1	Washer-Lock 3/8 Heavy
8	1-807019	2	Key-Woodruff 1 X 1/4	62	3256-4	3	Washer-3/8 Std
11	1-613089	2	Tab-Spring, Extension	63	323-9	1	Screw-HH 3/8-16 X 1 3/4
12	1-413510	3	Clip-Loom	64	1-806003	2	Hairpin-Cotter
19	103-1167	2	Joint-Ball End, .38X.38Fe LH	65	1-808280	2	Pin-Clevis 5/16 X 1 49/64
21	1-413010	2	Sheave ASM	66	3256-23	11	Washer-5/16 Sae
22	1-807272	2	Key-5Mm X 5Mm X 25Mm	67	1-403180	2	Screw-HH 5/16-18 X 1 3/8 Special
23	120-6474	4	Screw-Set, SQH ■	68	1-603903	1	Spacer
24	109-4077	1	Pulley-Idler, Flat	69	3219-2	7	Nut-Hex 5/16-24
25	1-603496	3	Bushing-Idler	70	3220-2	2	Nut-Jam 5/16-24
26	109-2578	1	Kit, Idler Arm W/Bearings	71	3256-2	2	Washer-1/4 Std
27	302-40	1	Zerk-90° 1/4-28	72	323-8	4	Screw-HH 3/8-16 X 1 1/2
28	1-603414	1	Spring-Extension	73	116-3515	2	Screw,HH Special 5/16-18 X 1.25
29	103-3506	1	Seal-Single Lip	74	1-805005	4	Washer-Lock 5/16 Heavy
30	302-19	2	Zerk-1/4-28 Str	75	1-809056	2	Screw-Sh 5/16-18 X 1 3/8 ■
31	1-633102	2	Bearing-Flanged	76	3256-24	3	Washer-3/8 Sae
32	1-613206	2	Rod, Control Arm	77	323-6	8	Screw-HH 3/8-16 X 1
33	1-323245	1	Spring-Compression	79	103-1576	2	Rod, Drive Lever
34	1-603676	2	Swivel-Adjustable, Short	80	1-803022	2	Setscrew-5/16-18 X 5/8 ■
35	103-3060	1	Knob-Tracking	81	3272-5	2	Pin-Cotter 3/32 X 1/2
36	116-1792-01	1	Support, Tank/Handle	83	103-2224	1	Shield, Drag
37	103-1561-01	1	Arm, Control LH	84	3256-3	3	Washer-5/16 Std
38	103-1562-01	1	Arm, Control RH ●	85	3220-16	2	Nut-Jam 3/8-24 LH
39	109-2584	1	Belt, Hyd Trans Drive (A-Section Belt)	86	3218-2	2	Nut-Jam 5/16-18
40	1-603693	2	Spring	87	103-5677	1	Spacer
41	103-2234-01	1	Crank Weldment	88	106-7159	2	O-Ring
42	1-603737	2	Bolt-Neutral Return	89	103-3505	1	Seal-Double Lip
43	103-0265	2	Spring, Neutral Return	90	32120-10	2	Ring-Retaining
44	1-603735	2	Bushing-Flanged	91	103-3504	2	Bearing-Spherical
45	1-303105	2	Yoke-Adjustable	92	1-633068	1	Arm-Lift, Deck
46	322-3	14	Screw-HH 5/16-18 X 3/4	93	98-5975	8	Washer-Spring Disc 3/8
47	103-2421	2	Tube, Pump Link Spacer	94	116-2839	2	Nut-Lock
48	3290-357	6	Nut-Whizlock 3/8-16				

● Not illustrated

■ Use Pro-Lock, Nut Type (P/N 1-840022, .5ml tube) on threads.

Park Brake and Engine Assembly

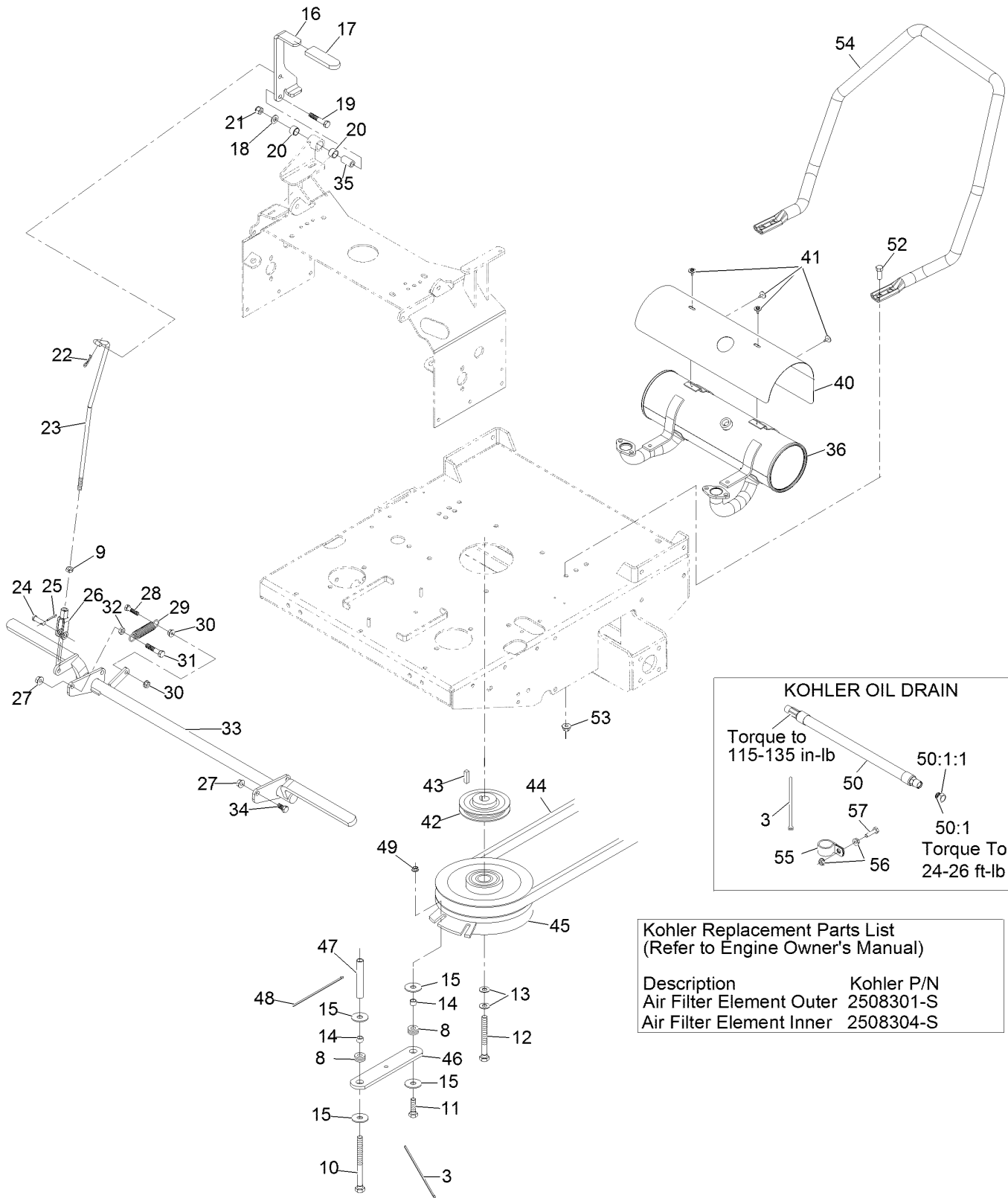

KOHLER OIL DRAIN

Torque to 115-135 in-lb

50:1:1

50:1

Torque To 24-26 ft-lb

Kohler Replacement Parts List
(Refer to Engine Owner's Manual)

Description	Kohler P/N
Air Filter Element Outer	2508301-S
Air Filter Element Inner	2508304-S

Park Brake and Engine Assembly (continued)

<i>Ref.</i>	<i>Part Number</i>	<i>Qty.</i>	<i>Description</i>	<i>Ref.</i>	<i>Part Number</i>	<i>Qty.</i>	<i>Description</i>
3	1-303335	2	Tie-Cable 7 15/16 (Large)	31	323-9	1	Screw-HH 3/8-16 X 1 3/4
8	1-633630	2	Grommet	32	3218-3	1	Nut-Jam 3/8-16
9	3220-3	1	Nut-Jam 3/8-24	33	103-2205-03	1	Brake Weldmt
10	322-38	1	Screw-HH	34	323-4	3	Screw-HH 3/8-16 X 3/4
11	322-6	1	Screw-HH 5/16-18 X 1 1/4	35	1-413344	1	Bushing-Pivot
12	3212-10	1	Screw-HH 7/16-20 X 2 1/2 ▲	36	116-8653	1	Muffler
13	1-603610	2	Washer-Spring Disc 7/16	40	116-8654	1	Shield-Muffler
14	1-633545	2	Spacer	41	116-1103	4	Screw-HH, Thread Forming
15	1-613235	4	Washer	42	1-653035	1	Pulley ●
16	109-4544	1	Lever, Park Brake W/Decal & Grip	43	1-807259	1	Key-Machine 1/4 X 1/4 X 1
17	1-303020	1	Grip-Lever	44	103-2240	1	Belt, Deck Drive(52)
18	3256-24	1	Washer-3/8 Sae	44	1-603306	1	Belt, Deck Drive(60)
19	322-10	1	Screw-HH 5/16-18 X 2	45	103-0662	1	Clutch ASM
20	1-413347	2	Sleeve-Bushing	46	1-633543-03	1	Strap-Clutch, Brake
21	3296-39	1	Nut-Nyloc 3/8-16	47	1-323195-03	1	Standoff, Clutch
22	1-806003	1	Hairpin-Cotter	48	1-303287	1	Tie-Cable 5 1/2 (Small)
23	109-4078	1	Linkage, Park Brake	49	32128-20	1	Nut-Whizlock 5/16-18
24	1-808285	1	Pin-Clevis 3/8 X 1 1/8	50	116-5316	1	Oil Drain Hose ASM ■
25	3272-10	1	Pin-Cotter 1/8 X 3/4	50:1	353-508	1	Plug-W/O-Ring
26	1-633131	1	Yoke-Linkage, Brake	50:1:1	237-42	1	O-Ring
27	3290-357	4	Nut-Whizlock 3/8-16	52	323-6	4	Screw-HH 3/8-16 X 1
28	116-3515	1	Screw,HH Special 5/16-18 X 1.25	53	104-8301	4	Nut-Nyloc 3/8-16 Flg
29	1-323161	1	Spring	54	116-8575-03	1	Guard-Air Cleaner
30	32128-20	6	Nut-Whizlock 5/16-18	55	1-643312	1	Clip-Loom
				56	32128-33	2	Nut-Whizlock 1/4-20
				57	321-6	1	Screw-HH 1/4-20 X 1

● Install sheave with long end of hub up.

■ Use a Teflon Pipe Sealant or equivalent on threads.

▲ Use Pro-Lock, Nut Type (P/N 1-840022, .5ml tube) on threads.

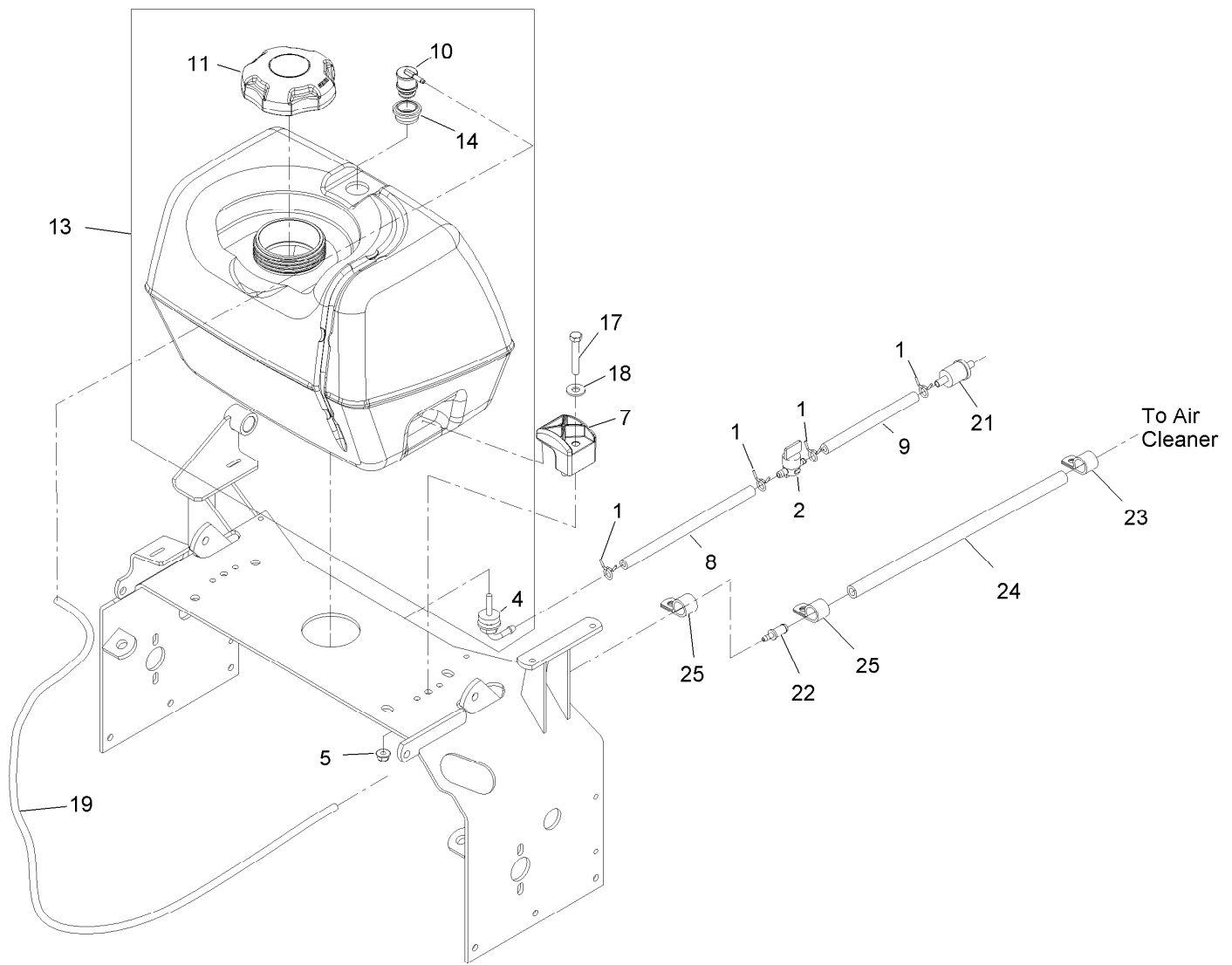

Fuel Tank Assembly

Ref.	Part Number	Qty.	Description	Ref.	Part Number	Qty.	Description
1	1-303077	4	Clamp-Fuel Line	13	116-3656	1	ASM, Fuel Tank
2	1-603770	1	Valve-Fuel	14	119-6549	1	Grommet-Valve, Roll-Over
4	103-2605	1	Fitting-Fuel Bulkhead W/Strainer ▲	17	322-10	2	Screw-HH 5/16-18 X 2
5	104-8300	2	Nut-Nyloc 5/16-18 Fig	18	3256-3	2	Washer-5/16 Std
7	107-4543	2	Clamp	19	116-3716	1	Hose-Fuel
8	110-1876	1	Hose-Fuel	21		1	Pn 240513-S Filter-Fuel ■●
9	110-1876	1	Hose-Fuel	22	98-2952	1	Fitting-Straight
10	114-0285	1	Valve-Rollover	23	1-633396	1	Clip-Loom 5/8
11	115-4465	1	Cap-Fuel, Ratcheting	24	116-4344	1	Hose-Fuel
				25	1-513762	2	Clip-Loom 1/2

● Not serviced separately

▲ Use Pro-Lock, Nut Type (P/N 1-840022, .5ml tube) on threads.

■ Obtain parts from www.kohlerplus.com

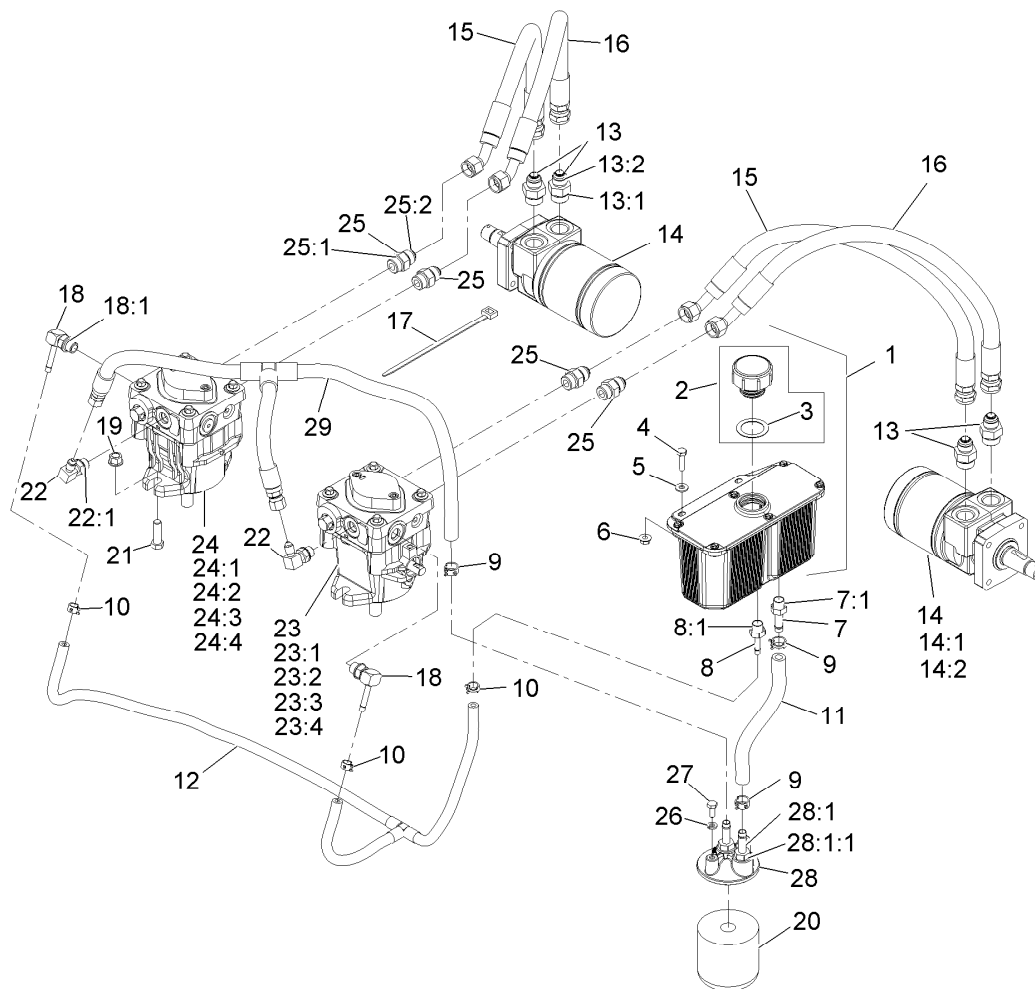

Hydraulics Assembly

Ref.	Part Number	Qty.	Description	Ref.	Part Number	Qty.	Description
1	103-1947	1	HYD Reservoir ASM	20	109-4180	1	Filter,25 Micron Bi-Directional
2	103-7615	1	Asm, Cap W/Gasket	20	1-523541	1	Element, Oil Filter(Winter)●
3	103-1949	1	Gasket-Cap	21	323-7	4	Screw-HH 3/8-16 X 1 1/4
4	321-6	2	Screw-HH 1/4-20 X 1	22	103-1802	2	Fitting-HYD, 90 DEG
5	3256-22	2	Washer-1/4 Sae	22:1	1-603921	1	O-Ring-Sae #6
6	32128-33	2	Nut-Whizlock 1/4-20	23	116-2495	1	Pump, Hydro RH
7	103-1912	1	Adapter-Straight	23:1	103-2664	1	Input Shaft Kit
7:1	1-603921	1	O-Ring-Sae #6	23:2	94-6922	1	Bearing-Thrust
8	103-1801	1	Adapter-Straight	23:3	103-2666	1	Cylinder Block Kit
8:1	1-603921	1	O-Ring-Sae #6	23:4	105-6184	1	Seal Overhaul Kit
9	103-1988	3	Clamp-Hose 11/16	24	116-2494	1	Pump, Hydro LH
10	103-1716	3	Clamp-Hose 17/32	24:1	103-2664	1	Input Shaft Kit
11	109-1010	1	Hose, Charge	24:2	94-6922	1	Bearing-Thrust
12	103-4607	1	Asm, Case Drain Hose	24:3	103-2666	1	Cylinder Block Kit
13	1-603991	4	Adapter-Straight	24:4	105-6184	1	Seal Overhaul Kit
13:1	1-603919	1	O-Ring-Sae #10	25	1-603990	4	Adapter-Straight
13:2	1-603992	1	O-Ring-37 Flare #8	25:1	1-603920	1	O-Ring-Sae #8
14	1-603718	2	HYD Motor ASM	25:2	1-603992	1	O-Ring-37 Flare #8
14:1	1-000119	1	Seal Kit	26	1-805004	2	Washer-Lock 1/4 Heavy
14:2	1-000138	1	Bearing And Seal Kit	27	321-3	2	Screw-HH 1/4-20 X 5/8
15	116-8646	2	Hose, Hydro	28	103-2889	1	Filter Head ASM
16	116-8647	2	Hose, Hydro	28:1	103-1912	2	Adapter-Straight
17	1-303335	1	Tie-Cable 7 15/16 (Large)	28:1:1	1-603921	1	O-Ring-Sae #6
18	103-1799	2	Elbow-90 DEG	29	103-4608	1	Asm, Charge Hose
18:1	1-603921	1	O-Ring-Sae #6				
19	32128-43	4	Nut-Whizlock 3/8-16				

● Use only for operation below 32°F (0°C).

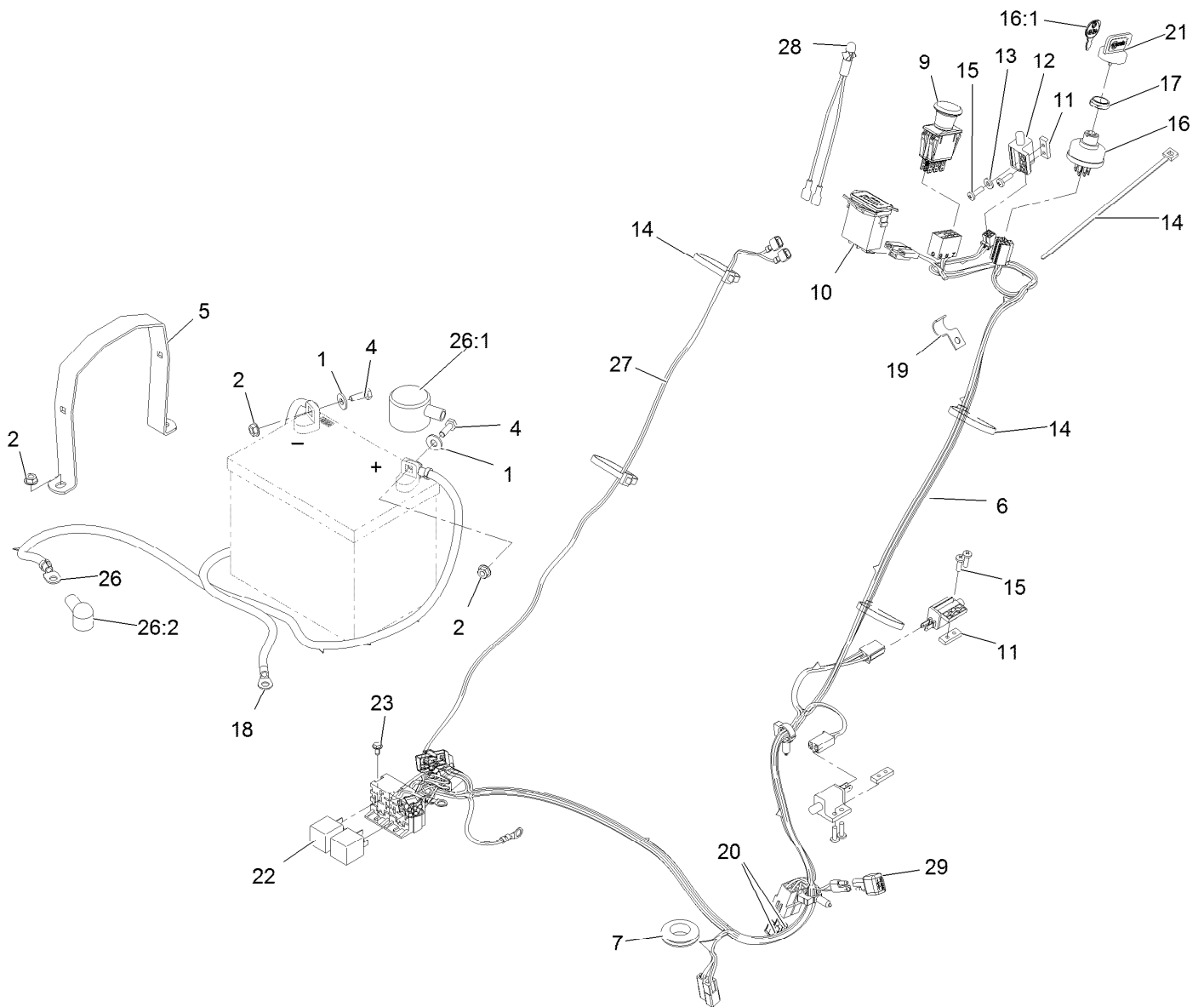

Electrical Assembly

<i>Ref.</i>	<i>Part Number</i>	<i>Qty.</i>	<i>Description</i>	<i>Ref.</i>	<i>Part Number</i>	<i>Qty.</i>	<i>Description</i>
1	3256-2	2	Washer-1/4 Std	16:1	1-603511	1	Key-Ignition
2	32128-33	4	Nut-Whizlock 1/4-20	17	103-0498	1	Nut-Ignition
4	321-4	2	Screw-HH 1/4-20 X 3/4	18	1-543767	1	Wire-Ground
5	1-603814-03	1	Strap, Battery Holddown	19	103-1193	2	Clip-Loom Half
6	116-8374	1	Harness, Wiring	20	1-816001	2	Fuse-Blade Type, 20 Amp
7	1-543286	1	Grommet	21	103-2106	1	Key-Exmark Logo
9	103-5221	1	Switch-PTO	22	1-643275	2	Relay-12Vdc 40 Amp
10	1-513374	1	Meter-Engine Hours	23	104-2065	2	Screw-HWH #10-24 X 3/8
11	1-633181	3	Plate-Tapped	26	109-7630	1	Positive Battery Cable ASM
12	1-513051	3	Switch-N.O.	26:1	109-2407	1	Insulator-Battery
13	3256-14	1	Washer-#10 Std	26:2	1-543393	1	Insulator-Solenoid
14	1-303335	5	Tie-Cable 7 15/16 (Large)	27	116-9205	1	Harness-Indicator Light [efi]
15	3290-500	6	Screw-PPH #10-24 X 5/8	28	1-643267	1	Indicator-Red Led
16	103-0206	1	Switch-Ignition W/Keys	29	103-3895	1	Diode-Tvs



Decals

Ref.	Part Number	Qty.	Description	Ref.	Part Number	Qty.	Description
1	116-4296	1	Decal, Console Ecs	12	1-303508	1	Decal-Warning, Discharge
2	116-0404	1	Decal-Hydraulic Tank	13	98-5954	3	Decal-Cover, Missing
3	103-2432	1	Decal, Brake Lever	14	109-3148	1	Decal, Bolt Torque
4	1-403143	1	Decal, Sulky Warning	15	103-2239	1	Decal, Belt Routing
5	103-4935	1	Decal, Drive Wheel Release	16	1-403005	2	Decal-Danger
6	117-2718	1	Decal-Arrester, Spark	17	103-2076	2	Decal-Caution
7	1-413214	1	Decal, Tracking	18	116-3883	2	Decal-X-Series
8	1-303517	1	Decal,Belt Drive	19	116-0034	1	Decal,Ultracut 52 Series 4
9	103-2242	1	Decal, Ecs Instruction LH	20	103-3013	1	Decal, Turf Tracer
10	103-2243	1	Decal, Ecs Instruction RH	21	103-2882	1	Decal, Exmark Logo
11	1-553049	1	Decal, Mower Deck	99	103-5828	1	Kit, Decal Complete •

• Not illustrated

Notes:

EXMARK® MAINTENANCE

MAXIMIZE THE PERFORMANCE OF YOUR EXMARK.

4-CYCLE PREMIUM ENGINE OIL

Part No. 116-3373

Both SAE 30 and SAE 10W-30 in one bottle.

Contains increased levels of zinc and phosphorus for better lubricity.

No Viscosity Index Improvers that tend to shear down in high heat.

Synthetic formulation.

Gas & Diesel compatible.

Anti-corrosion additives.

API 'SL' and JASO rated with wet clutch compatibility for other machines.

PREMIUM HYDRO OIL

Part No. 109-9828

Commercial quality for tough, high-heat conditions.

Designed specifically for zero-turn mower hydraulic systems.

Superior shear resistance under heavy loads.

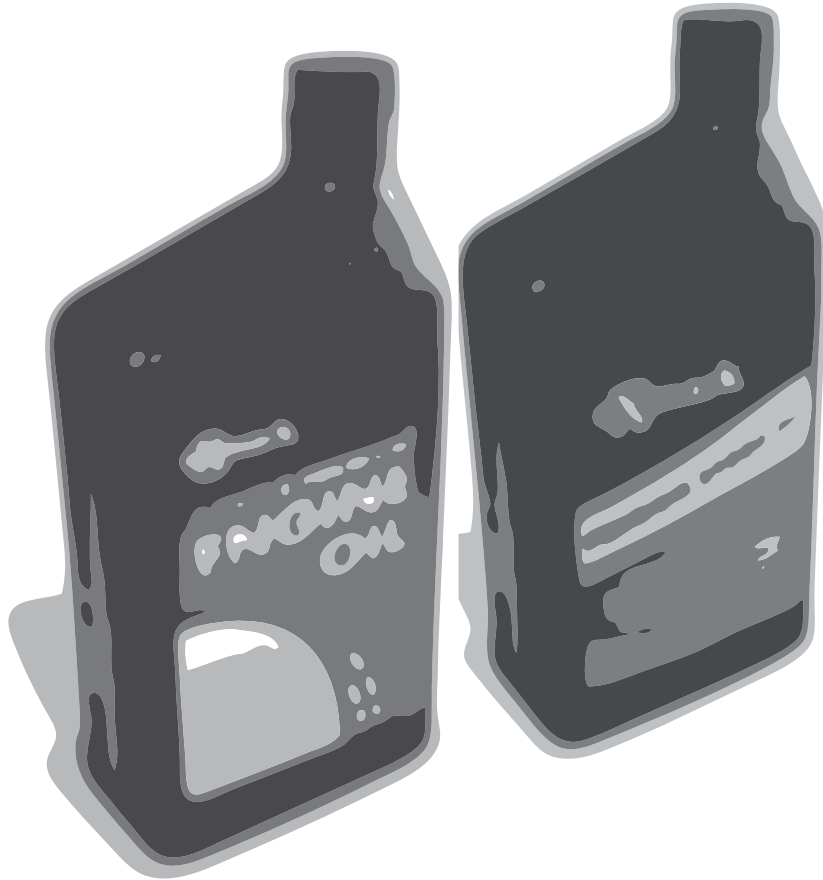

Available from your local Exmark dealer. Find your closest dealer at exmark.com

EXMARK ACCESSORIES AND OPTIONS*

MID-MOUNT RIDING ACCESSORIES AND OPTIONS

CUSTOM RIDE SEAT SUSPENSION SYSTEM	OPERATOR CONTROLLED DISCHARGE
FULL SUSPENSION SEAT	SUN SHADE
DECK LIFT ASSIST KIT	TRASH CONTAINER
HITCH KIT	TURF STRIPER
LIGHT KIT	ULTRA VAC COLLECTION SYSTEM
12V POWER PORT	ULTRA VAC QUICK DISPOSAL SYSTEM
MICRO-MULCH SYSTEM	

OUT-FRONT RIDING ACCESSORIES AND OPTIONS

CUSTOM RIDE SEAT SUSPENSION SYSTEM	SNOW BLADE
DUAL-TAIL WHEEL	SNOWBLOWER
FLOOR PAN EXTENDER	SUN SHADE
HITCH KIT	TRASH CONTAINER
LIGHT KIT	ULTRA VAC COLLECTION SYSTEM
MICRO-MULCH SYSTEM	ULTRA VAC QUICK DISPOSAL SYSTEM
ROLL OVER PROTECTION SYSTEM (ROPS)	WEATHER CAB

WALK-BEHIND ACCESSORIES AND OPTIONS

GRASS CATCHER	TURF STRIPER
MICRO-MULCH SYSTEM	STANDON

*Some accessories and options not available for some models.

Place Model No. and Serial No.
Label Here (Included in the Literature
Pack) or Fill in Below

Model No. _____

Serial No. _____

Date Purchased _____

Engine Model No. and Spec. No. _____

Engine Serial No. (E/No) _____

© 2012 Exmark Mfg. Co., Inc.
Industrial Park Box 808
Beatrice, NE 68310
All Rights Reserved

Part No. 4501-462 Rev. A
(402) 223-6300
Fax (402) 223-5489
Printed in the USA.

