

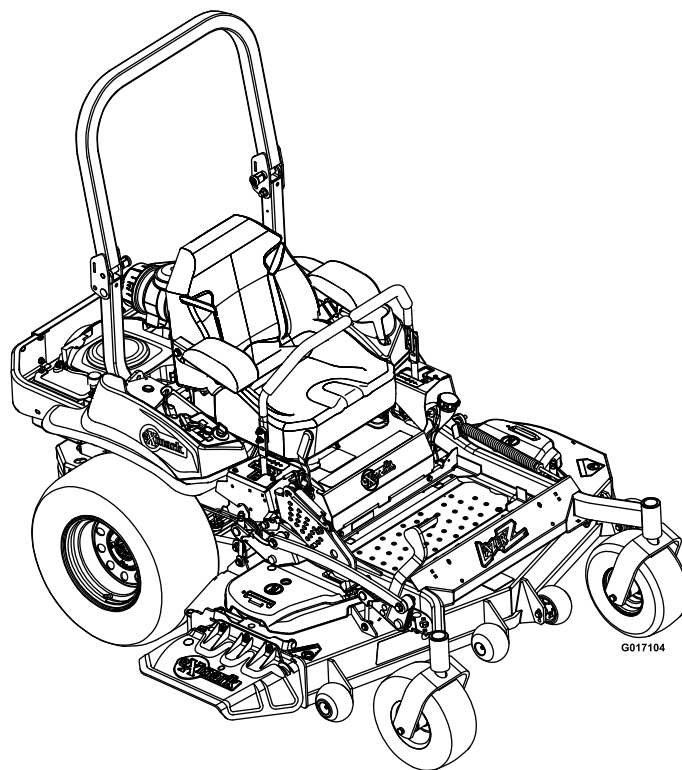

# LAZER Z<sup>®</sup> X-SERIES

Model No. LZX980EKC726—Serial No. 31300000 and Up

Picture below may not reflect actual product.



# Parts Manual

# Ordering Replacement Parts

To order replacement parts, please supply the part number, the quantity, and the description of each part desired.

## Understanding Reference Numbers

Each identified part in an illustration has a reference number. The reference number for a part also appears in the parts list, along with other information about the part.

This catalog uses two special reference number formats, one to indicate parts in a service assembly and another to indicate the quantity of a given part in an illustration.

## Service Assembly Reference Numbers

Parts in service assemblies have reference numbers in the form a:b. The a represents the reference number of the entire service assembly and the b represents a sequential number unique to each part within the service assembly.

For example, a wheel assembly might be identified by reference number 6, the tire by 6:1, the valve by 6:2, and the wheel by 6:3. When you order the assembly identified by reference number 6, you receive all parts identified by reference numbers 6:1, 6:2, and 6:3. However, you may also order any part individually. Reference numbers of this type appear in illustration and in parts lists.

## Reference Numbers Indicating Quantity

In an illustration, if a reference number indicates more than one part, the reference number has the form nX y. The n represents the quantity of the part, the X is the multiplication symbol, and the y represents the reference number.

For example, in an illustration, the reference number 2X 37 means that two of the parts identified by reference number 37 are indicated.

# List of Abbreviations

<b>AR:</b> as required	<b>HJ:</b> hex jam	<b>PRH:</b> phillips round head
<b>ASM:</b> assembly	<b>HLH:</b> hex lag head	<b>PTH:</b> phillips truss head
<b>BBC:</b> blade brake control	<b>HOC:</b> height-of-cut	<b>PTO:</b> power-take-off
<b>BHTF:</b> button head thread forming	<b>HSBH:</b> hex socket button head	<b>RH:</b> right hand
<b>CARR:</b> carriage	<b>HSFH:</b> hex socket flat head	<b>ROPS:</b> roll-over protection system
<b>CCW:</b> counter clockwise	<b>HSH:</b> hex socket head	<b>RRB:</b> rear roller brush
<b>CW:</b> clockwise	<b>HWH:</b> hex washer head	<b>SFH:</b> slotted fillister head
<b>DEG:</b> degrees	<b>HWHTF:</b> hex washer head thread forming	<b>SHH:</b> slotted hex head
<b>DPA:</b> Dual Point Adjustment	<b>HYD:</b> hydraulic	<b>SHWH:</b> slotted hex washer head
<b>ECM:</b> electronic control module	<b>LH:</b> left hand	<b>SPH:</b> slotted pan head
<b>EXT:</b> external	<b>LP:</b> Liquefied Petroleum Gas	<b>SQH:</b> square head
<b>FH:</b> flat head	<b>LPG:</b> Liquefied Petroleum Gas	<b>SRH:</b> slotted round head
<b>GA:</b> gauge	<b>NI:</b> nylon insert	<b>STD:</b> standard
<b>HD:</b> heavy-duty	<b>NPTF:</b> national pipe thread fine	<b>TAP:</b> self tapping
<b>HF:</b> hex flange	<b>PFH:</b> phillips flat head	<b>TTH:</b> torx truss head
<b>HH:</b> hex head	<b>PPH:</b> phillips pan head	
<b>HHF:</b> hex head flange	<b>PPHTF:</b> phillips pan head thread forming	
<b>HHFTF:</b> hex head flange thread forming		

# Touch Up Paint

Exmark black touch up spray paint – gloss black.

Exmark red touch up paint (spray paint – P/N 1-850337 - .6 oz liquid bottle – P/N 103-9140).



If your Exmark dealer does not have the Exmark part in stock, Exmark will get the parts to the dealer the next business day or the part will be FREE Guaranteed!! (Some restrictions apply. See your participating Exmark Dealer for details.)

## Contents

Complete Deck Assembly.....	4
Deck Assembly.....	5
Deck W/Decals No. 109-9133.....	6
Deck Idler Assembly No. 116-3755.....	7
Cutter Housing Assembly No. 103-9539.....	8
Main Frame Assembly.....	9
Roll-Over Protection System Assembly No. 116-0230.....	10
Caster Wheel and Fork Assembly.....	11
Deck Lift Assembly.....	12
Height-of-Cut Assembly No. 109-7438.....	13
Controls Assembly.....	14
Motion Control Assembly.....	15
Rear Wheel and Park Brake Assembly.....	16
Parking Brake Handle Assembly No. 116-7551.....	17
Seat Assembly.....	18
Seat W/Tracks Assembly No. 116-8912.....	19
Fuel Assembly.....	20
Fuel Tank Assembly No. 116-3979.....	21
Engine Assembly.....	22
Hydraulic Assembly.....	23
LH Hydro Assembly No. 116-6409.....	24
RH Hydro Assembly No. 116-6410.....	25
Pump Idler Assembly No. 116-1255.....	26
Electrical Assembly.....	27

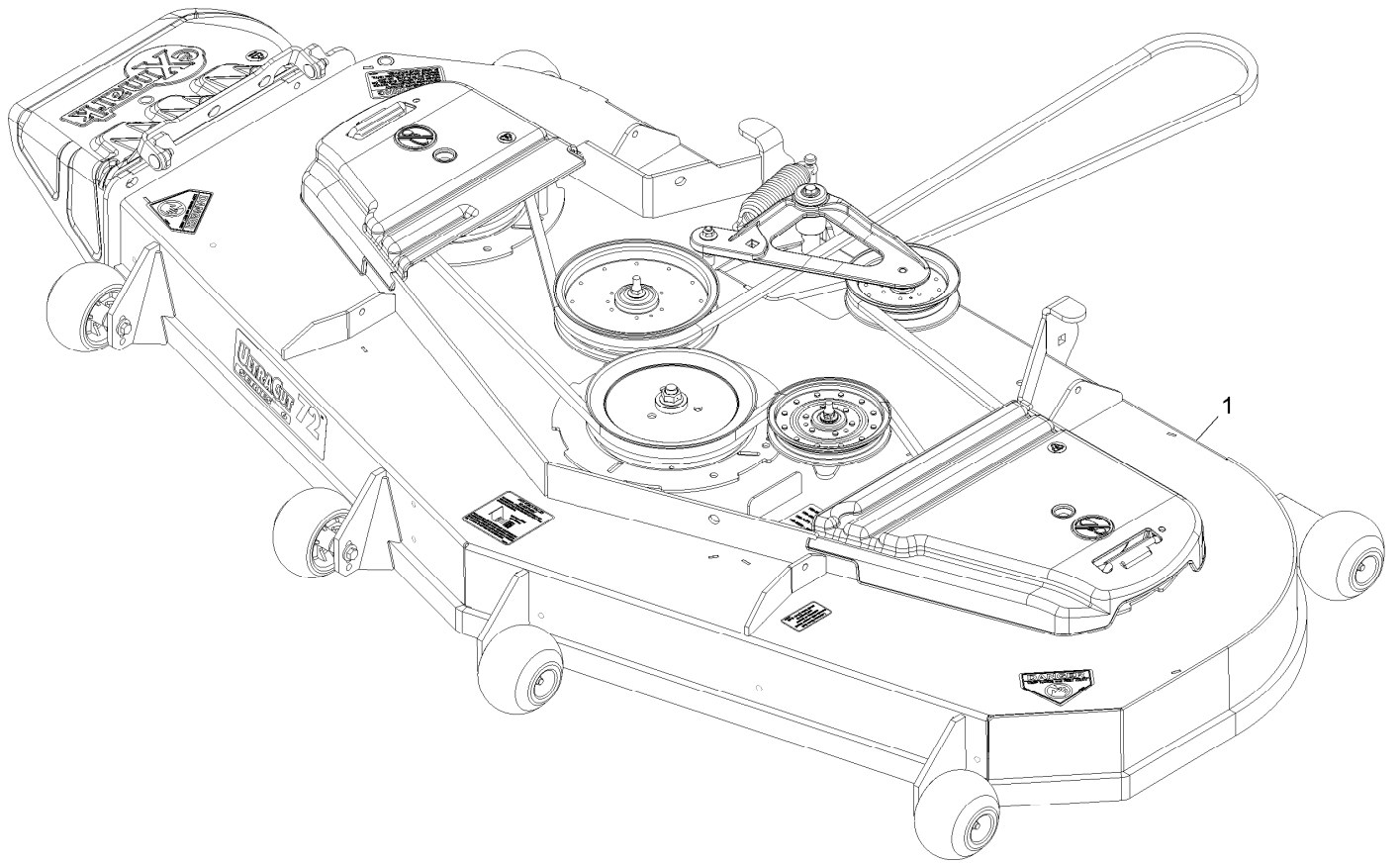

## Complete Deck Assembly

<i>Ref.</i>	<i>Part Number</i>	<i>Qty.</i>	<i>Description</i>
1	109-9649	1	Complete Deck ASM-726

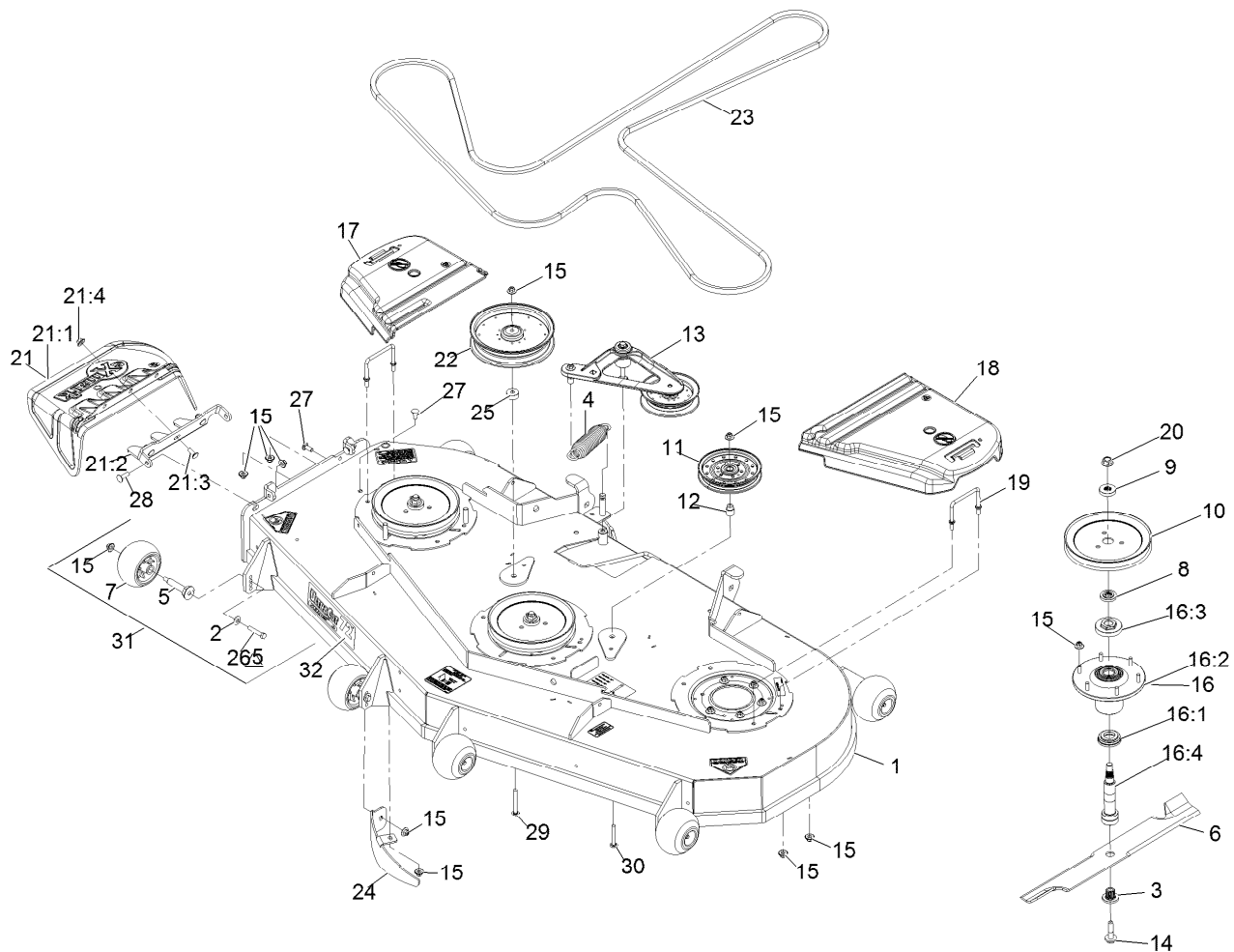

## Deck Assembly

Ref.	Part Number	Qty.	Description	Ref.	Part Number	Qty.	Description
1	109-9133	1	Deck W/ Decals ASM-72	16:3	109-0916	1	Nut, Spindle 7/8-14
2	98-5975	6	Washer-Spring Disc 3/8	16:4	109-6881	1	Spindle,Double Spline ■
3	103-3037	3	Bushing, Splined	17	116-0094	1	Cover-Belt, RH
4	116-6317	1	Spring-Extension	18	109-6938	1	Cover-Belt, LH
5	109-9851	6	Axle, Anti-Scalp Roller	19	109-6982	2	Wireform-Cover
6	116-5171	3	Blade-Extreme 2, 24.50"	20	109-7033	3	Nut-Flange 5/8-18 Centerlock
6	103-6384	3	Blade, Solid (72")	21	109-7188	1	ASM,Discharge Chute
6	103-6389	3	Blade, Low Lift (72")	21:1	109-2738	1	Chute, Discharge
6	103-6394	3	Blade, Mulching (72") ●	21:2	109-8675-01	1	Bracket,Discharge Chute
6	103-6404	3	Blade, Notched (72")	21:3	3231-22	3	Bolt-Carriage 3/8-16 X 1
7	103-8415	6	Roller, Anti-Scalp 46" And 50"	21:4	109-6658	3	Nut-Nyloc 3/8-16 Flg
8	103-9522	3	Spacer, Splined Stepped	22	109-8590	1	Pulley-Idler
9	103-9523	3	Spacer, Splined	23	109-9023	1	Belt,V-5V X 219.00"
10	109-2180	3	Sheave,Blade Drive 9.00	24	116-5834-01	1	Baffle-Dogleg, Lz72
11	116-4667	1	Idler-Pulley, Flat	25	103-2956	1	Spacer-Idler
12	1-633456	1	Bushing, Idler	26	3211-46	6	Screw-HH 3/8-24 X 2 Gr8
13	116-3755	1	Deck Idler ASM	27	3231-22	2	Bolt-Carriage 3/8-16 X 1
14	109-9220	3	Screw-Sems 1/2-20 X 2.19	28	3231-28	2	Bolt-Carriage 3/8-16 X 1 1/4
15	109-6658	34	Nut-Nyloc 3/8-16 Flg	29	3231-42	1	Bolt-Carriage 3/8-16 X 3
16	109-6917	3	ASM,Spindle Housing	30	3231-44	1	Bolt-Carriage 3/8-16 X 2 1/2
16:1	103-9504	1	Guard, Bottom	31	109-2098	6	Kit, Antiscalp 46" And 50"
16:2	103-9539	1	Asm, Cutter Housing	32	109-9440	1	Decal,Ultracut 72 Series 6

● Requires installation of mulch kit for proper mulching. See your Exmark dealer for details.

■ Apply Mobil HTS grease (P/N 103-5217 1.5 oz packet) (or a food-grade anti-seize). See operator s manual for locations.

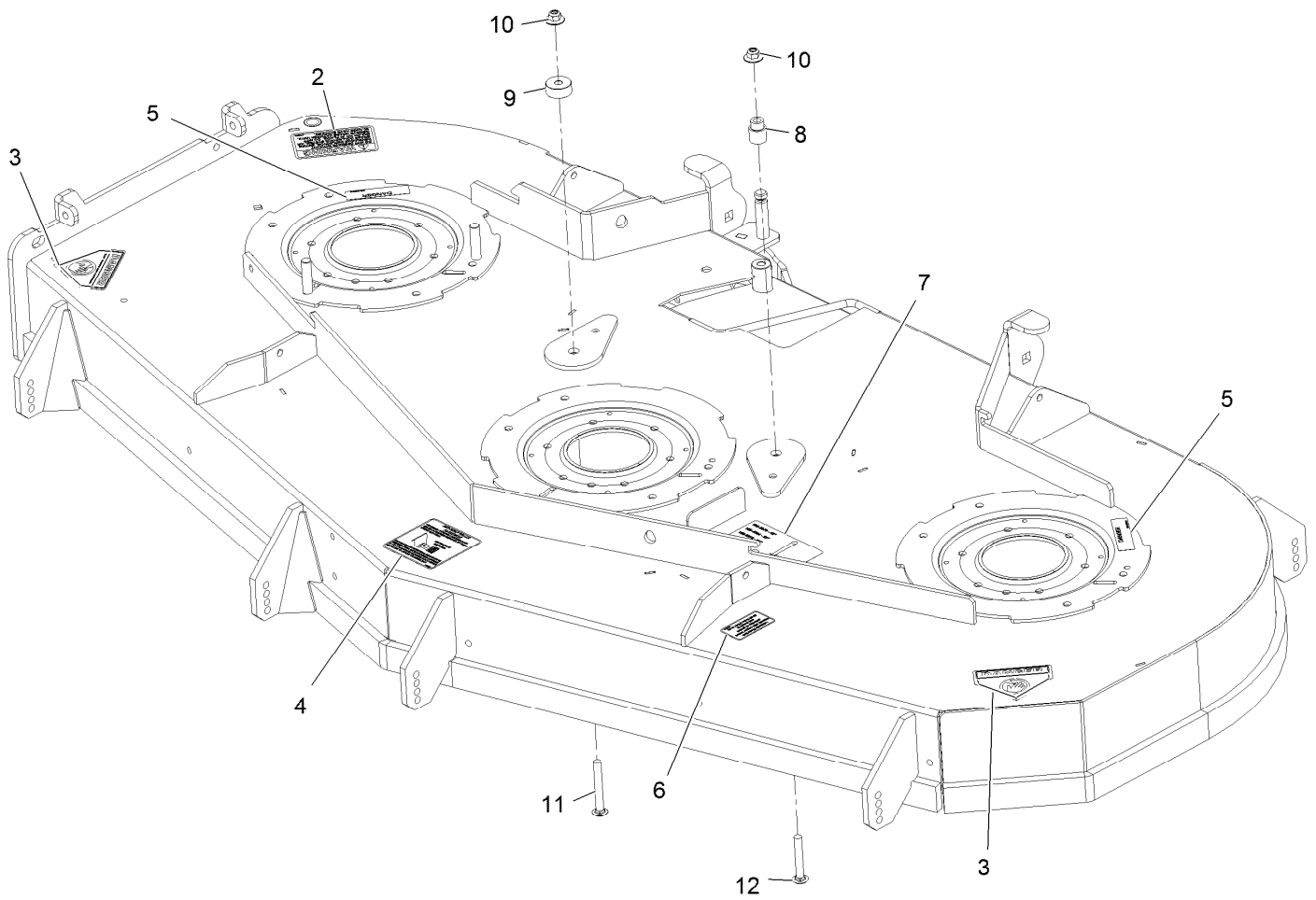

## Deck W/Decals No. 109-9133

Ref.	Part Number	Qty.	Description
2	1-303508	1	Decal-Warning, Discharge
3	1-403005	2	Decal-Danger
4	1-633922	1	Decal, Anti-Scalp
5	98-5954	2	Decal-Cover, Missing
6	109-3148	1	Decal, Bolt Torque
7	109-9361	1	Decal,Belt Routing
8	1-633456	1	Bushing, Idler
9	103-2956	1	Spacer-Idler
10	109-6658	2	Nut-Nyloc 3/8-16 Flg
11	3231-42	1	Bolt-Carriage 3/8-16 X 3
12	3231-44	1	Bolt-Carriage 3/8-16 X 2 1/2



## Deck Idler Assembly No. 116-3755

<i>Ref.</i>	<i>Part Number</i>	<i>Qty.</i>	<i>Description</i>
1	43-0940	1	Spacer
2	103-2916	1	Guard-Top
3	103-3504	2	Bearing-Spherical
4	103-3505	1	Seal-Double Lip
5	103-3506	1	Seal-Single Lip
6	116-4668	1	Idler-Pulley, Flanged
7	106-7159	2	O-Ring
9	116-3467	1	Pin-Spring, Anchor
10	109-6658	2	Nut-Nyloc 3/8-16 Flg
11	109-7409	1	Screw-Shoulder 3/8-16 X 5
12	323-8	1	Screw-HH 3/8-16 X 1 1/2
13	32120-10	2	Ring-Retaining
14	302-19	1	Zerk-1/4-28 Str

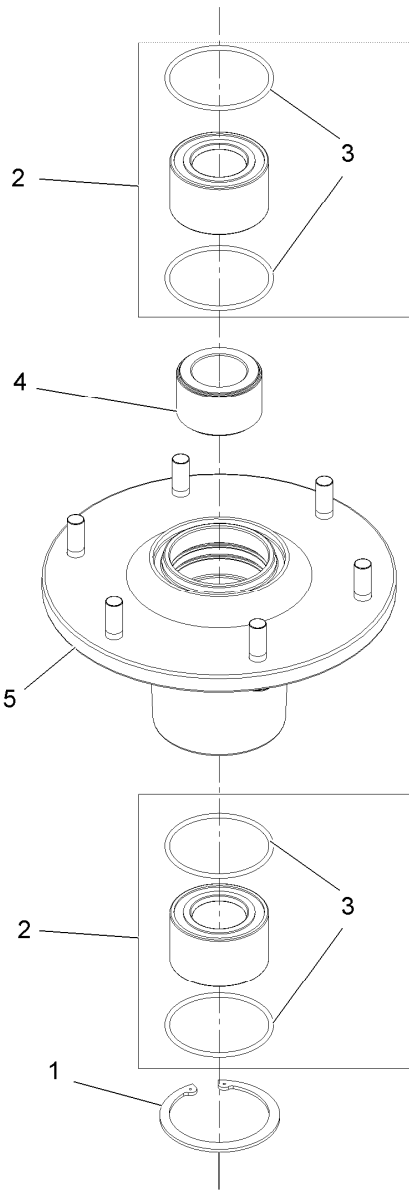

## Cutter Housing Assembly No. 103-9539

<i>Ref.</i>	<i>Part Number</i>	<i>Qty.</i>	<i>Description</i>
1	92-5581	1	Ring-Retaining
2	109-2064	1	Asm, Bearing W/O-Rings
3	103-5895	4	O-Ring
4	103-9506	1	Spacer, Bearing
5	109-0764	1	Asm, Housing W/Studs



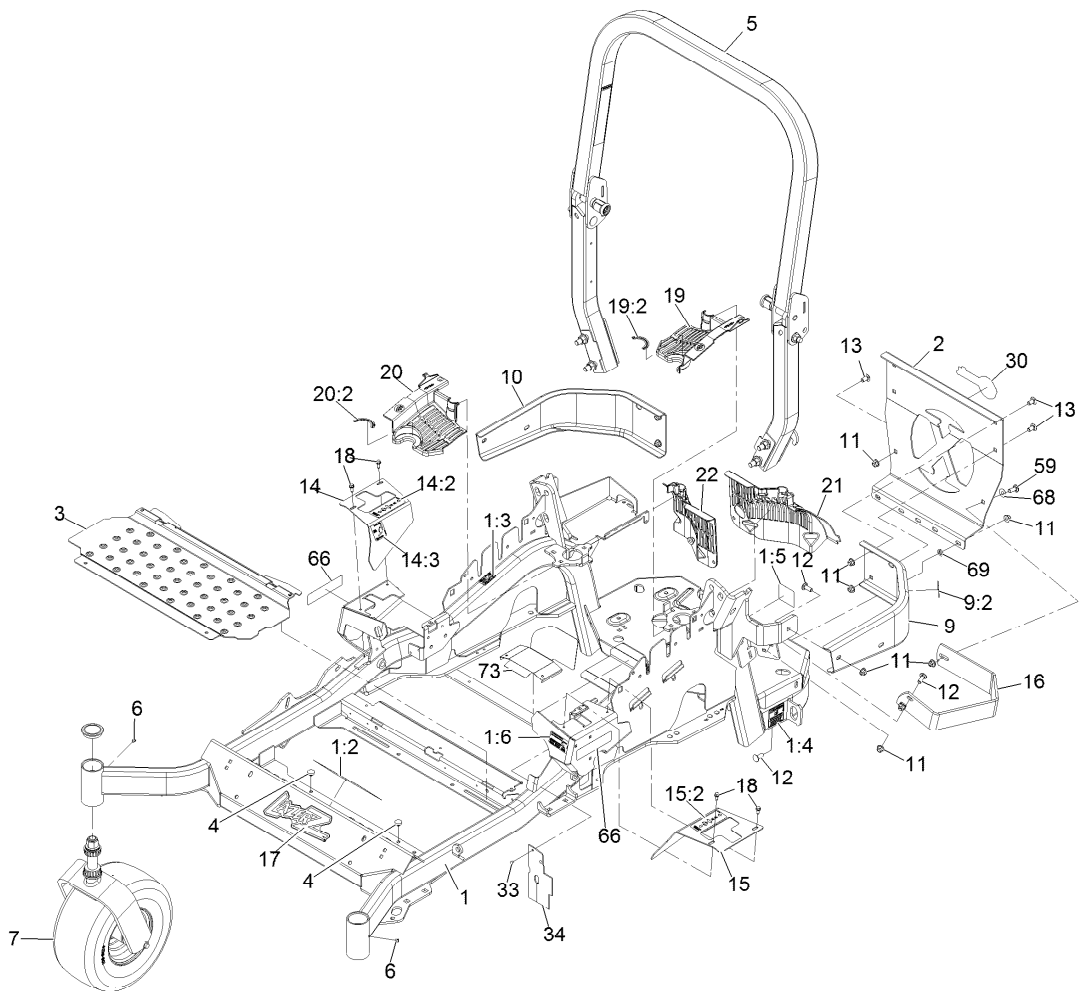

## Main Frame Assembly

Ref.	Part Number	Qty.	Description	Ref.	Part Number	Qty.	Description
1	116-5904	1	Mainframe ASM	14:3	116-5944	1	Decal-Park Brake
1:2	103-2076	2	Decal-Caution	15	116-0580	1	LH Motion Control Cover ASM
1:3	116-3303	1	Decal-Slope	15:2	109-7232	1	Decal-Motion Control
1:4	116-0205	2	Decal-Belt Drive	16	116-0043-03	1	Guard-Muffler
1:5	116-4858	1	Decal-Spark Arrester	17	103-3113	1	Decal, Lazer Model
1:6	116-1654	1	Decal-Fuel Fill	18	32144-10	4	Screw-HWH 1/4-20 X .62
2	109-8863-03	1	Plate,Rear Guard	19	116-0170	1	LH Hydro Guard ASM
3	116-8898-01	1	Floorpan	19:2	116-0157	1	Decal-Hydro Oil
4	1-513658	2	Bumper	20	116-0171	1	RH Hydro Guard ASM
5	116-0230	1	ASM,ROPS Service Exmark	20:2	116-0157	1	Decal-Hydro Oil
6	1-811010	2	Plug	21	109-9709	1	Guard-Hydro Rear, LH Trim
7		2	Caster Wheel ASM ●	22	109-9058	1	Guard-Hydro, Rear RH
9	116-0180	1	LH Bumper ASM	30	103-2883	1	Decal, Exmark Logo
9:2	103-2076	1	Decal-Caution	33	1-803035	2	Rivet 3/16 X 1/4
10	116-0057-03	1	Bumper-RH	34	116-2362	1	Deflector-Air Flow
11	104-8301	11	Nut-Nyloc 3/8-16 Flg	59	323-6	1	Screw-HH 3/8-16 X 1
12	3231-22	13	Bolt-Carriage 3/8-16 X 1	66	116-3883	2	Decal-X-Series
13	3231-21	4	Bolt-Carriage 3/8-16 X 3/4	68	3256-24	1	Washer-3/8 Sae
14	116-5899	1	RH Motion Control Cover ASM	69	107-3154	2	Nut-Push 3/8-16
14:2	109-7232	1	Decal-Motion Control	73	126-0032-01	1	Guard-Exhaust

● Not serviced separately

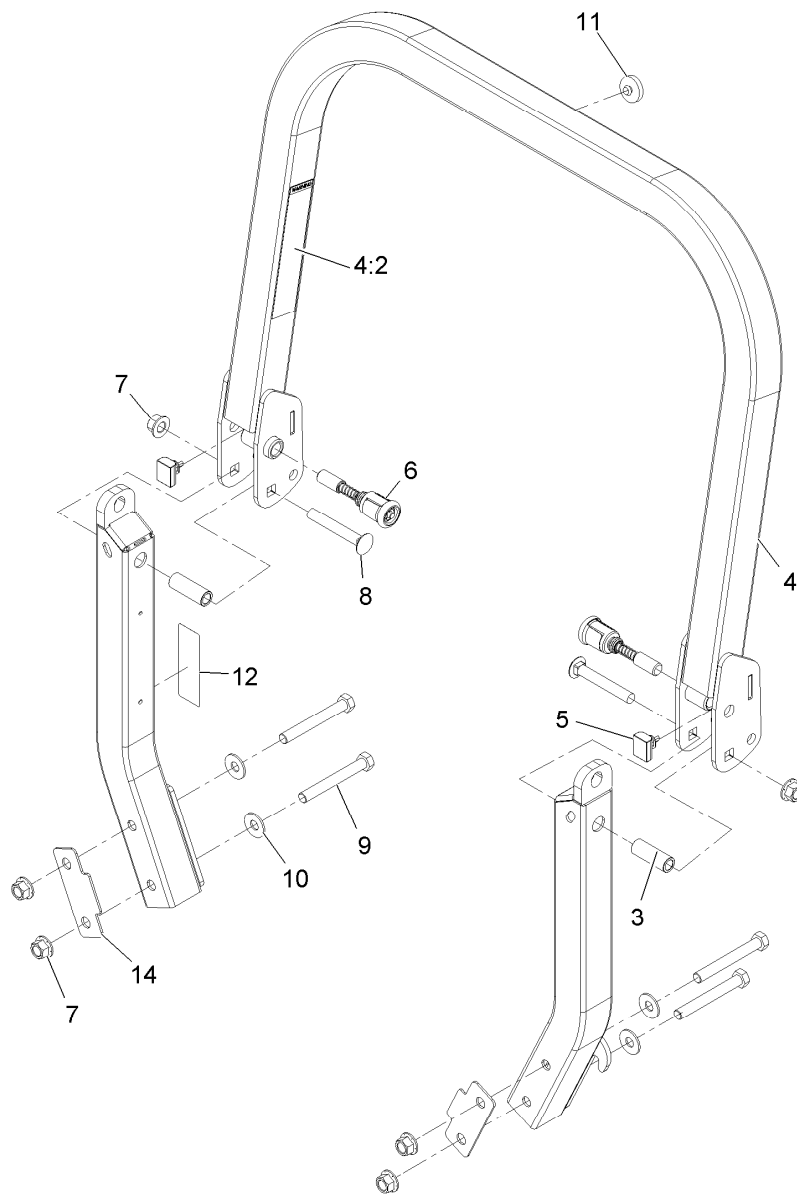

## Roll-Over Protection System Assembly No. 116-0230

<i>Ref.</i>	<i>Part Number</i>	<i>Qty.</i>	<i>Description</i>
3	109-6653	2	Spacer
4	116-0019	1	Upper ROPS ASM
4:2	107-2102	1	Decal-Warning, Folding ROPS
5	109-5337	2	Bumper-ROPS
6	116-0104	2	Pin-Spring
7	99-5107	6	Nut-Lock 1/2-13
8	3233-10	2	Bolt-Carriage 1/2-13 X 3 1/2
9	325-17	4	Screw-HH 1/2-13 X 4
10	109-9505	4	Washer-Spring
11	109-9233	1	Bumper-Push-In, Rubber
12	116-0090	1	Decal-Caution
14	116-0960	2	Spacer

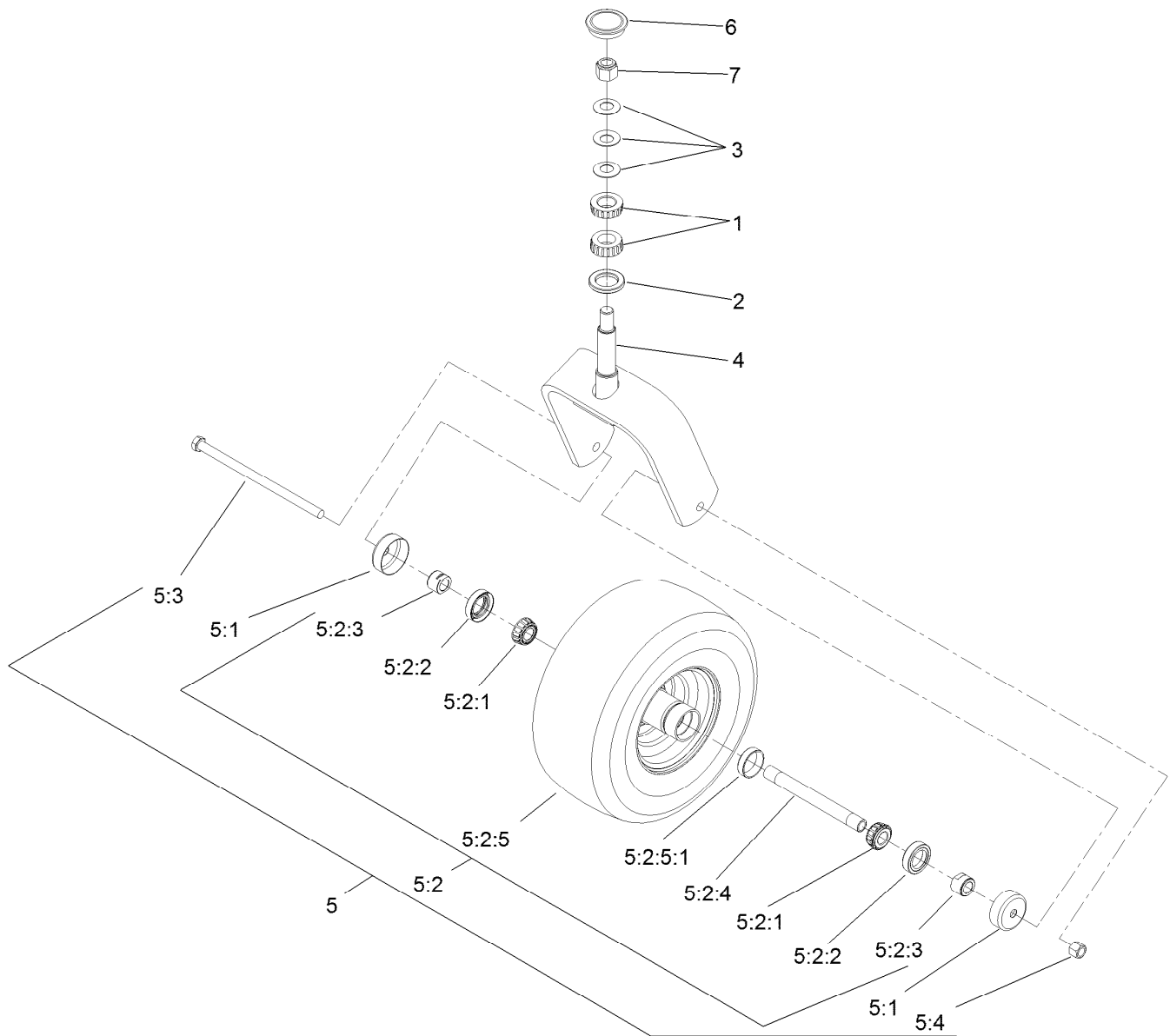

## Caster Wheel and Fork Assembly

Ref.	Part Number	Qty.	Description	Ref.	Part Number	Qty.	Description
1	1-543509	2	Bearing-Roller, Tapered	5:2:3	103-3051	2	Spacer-Nut ■
2	116-5647	1	Seal-Grease	5:2:4	103-5156	1	Axle-Caster
3	1-633508	3	Washer-Bellville	5:2:5		1	Wheel And Tire ASM ●
4	116-6707-01	1	Caster	5:2:5:1	1-633584	1	Bearing-Cup
5	109-9127	1	Wheel And Tire ASM	5:3	325-39	1	Screw-HH
5:1	103-2768	2	Guard-Seal	5:4	3296-23	1	Nut-Lock, NI
5:2		1	Wheel And Tire ASM ●	6	103-4882	1	Cap-Grease
5:2:1	1-633585	2	Bearing-Cone, Taper	7	3296-51	1	Nut-Lock, NI
5:2:2	103-0063	2	Seal-Caster				

● Not serviced separately

■ Use Pro-Lock, Nut Type (P/N 1-840022, .5ml tube) on threads.

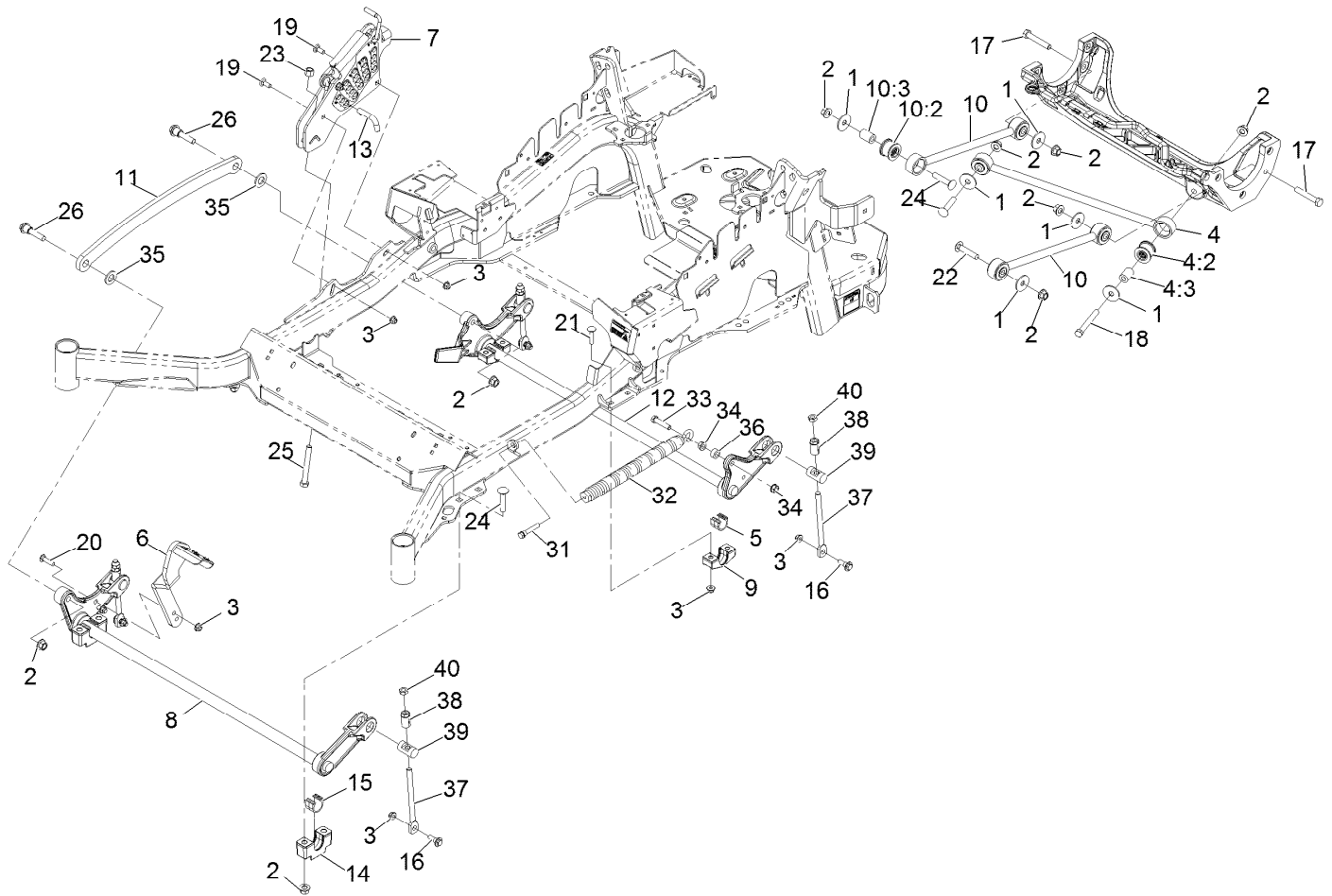

## Deck Lift Assembly

Ref.	Part Number	Qty.	Description	Ref.	Part Number	Qty.	Description
1	86-1990	6	Washer	17	325-12	2	Screw-HH 1/2-13 X 3
2	99-5107	12	Nut-Lock 1/2-13	18	325-17	1	Screw-HH 1/2-13 X 4
3	104-8301	12	Nut-Nyloc 3/8-16 Flg	19	3231-2	2	Bolt-Carriage 3/8-16 X 1
4	109-5013	1	Panhard Rod ASM	20	3231-4	2	Bolt-Carriage 3/8-16 X 1 1/2
4:2	109-5009	2	Bushing-Suspension, Rubber	21	3231-5	4	Bolt-Carriage 3/8-16 X 1 3/4
4:3	109-5010	2	Spacer	22	3233-34	3	Bolt-Carriage 1/2-13 X 2 1/2
5	109-7173	2	Bearing-Cross Shaft, Rear	23	3296-23	1	Nut-Nyloc 1/2-13
6	116-1919-01	1	Lever-Foot	24	116-1700	4	Bolt-Carriage 1/2-13 X 2 1/2 Spl Neck
7	109-7438	1	HOC ASM	25	116-0559	1	Bolt-HH 1/2-13 X 4 Tap
8	116-1771-03	1	Deck Lift-Front	26	116-2022	2	Screw-Hex Flange 1/2-13 X 1.90
9	116-0818-03	2	Support-Cross Shaft, Rear Bearing	31	92-7674	1	Screw-Shcs 3/8-16 X 2.212
10	109-7952	2	Deck Strut ASM	32	116-0000	1	Extension Spring ASM
10:2	109-5009	2	Bushing-Suspension, Rubber	33	109-9065	1	Screw-HH 7/16-14 X 2
10:3	109-5010	2	Spacer	34	32128-37	2	Nut-Whizlock 7/16-14
11	116-0797-03	1	Link-Lift, Deck	35	3256-28	2	Washer-3/4 Sae
12	116-2645-03	1	Lift-Deck, Rear	36	116-2695	1	Spacer
13	116-5584	1	Pin-HOC	37	109-8007	4	Link-Adjuster, Deck Lift
14	109-9409	2	Support-Cross Shaft, Front Bearing	38	109-7840	4	Adjuster-Lift, Deck
15	109-9410	2	Bearing-Cross Shaft, Front	39	109-8353	4	Trunnion
16	109-9840	4	Screw-Hex Flange 3/8-16 X .80	40	3218-5	4	Nut-Jam 1/2-13

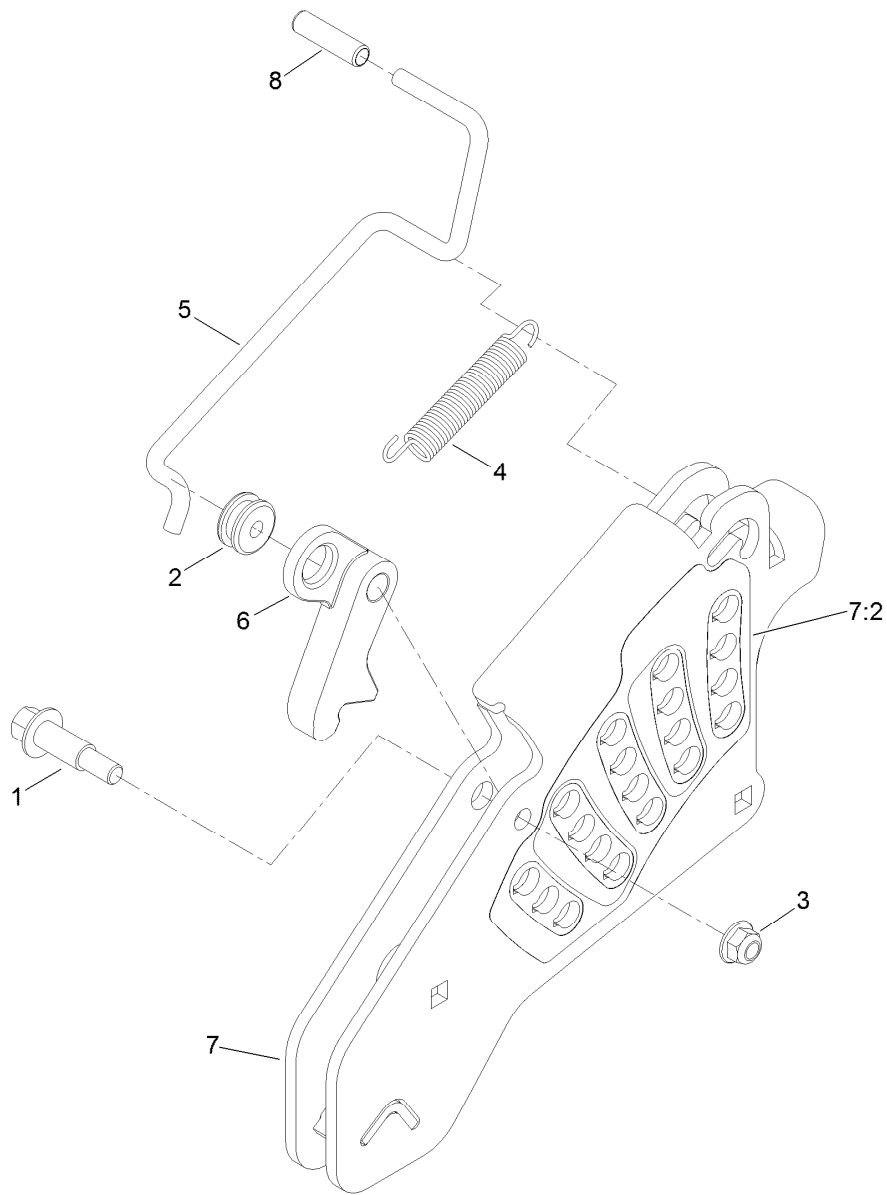

## Height-of-Cut Assembly No. 109-7438

<i>Ref.</i>	<i>Part Number</i>	<i>Qty.</i>	<i>Description</i>
1	62-1330	1	Bolt-Shoulder
2	109-7130	1	Grommet
3	104-8301	1	Nut-Flange, NI
4	109-7124	1	Spring-Extension
5	109-7128	1	Rod-Lock, Transport
6	116-0118	1	Pawl-Transport, HOC
7	109-7335	1	HOC Plate ASM
7:2	116-0752	1	Decal-HOC
8	109-8250	1	Grip-Lever

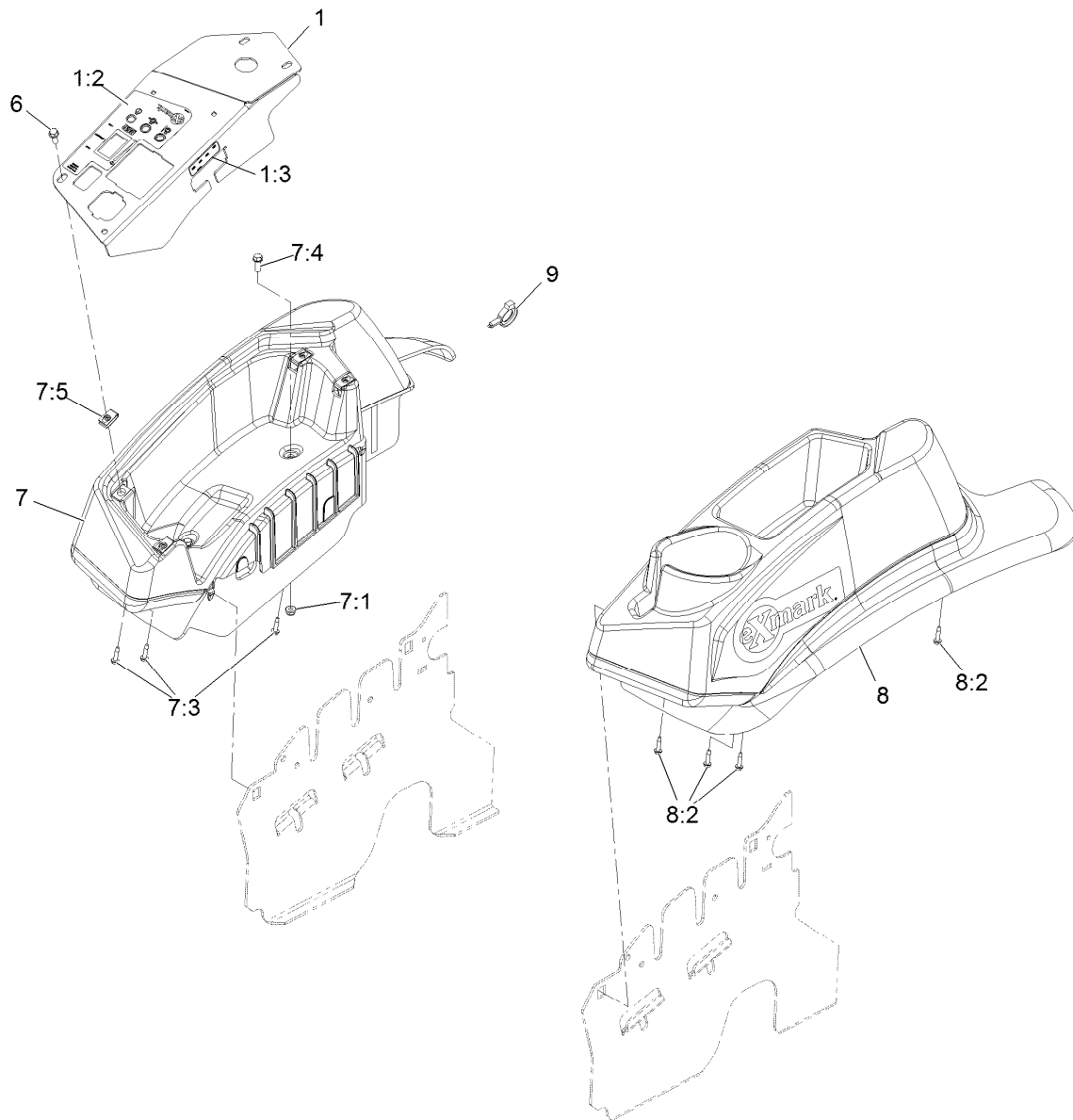

## Controls Assembly

Ref.	Part Number	Qty.	Description
1	116-9416	1	Control Panel W/Decal
1:2	116-9121	1	Decal-E-Gov Control
1:3	109-7330	1	Decal-Fuse
6	32105-15	4	Screw-Machine 1/4-20 X 3/4
7	109-9341	1	Console,RH Narrow ASM
7:1	104-7201	2	Nut-Nyloc 1/4-20 Flg
7:3	109-9345	3	Screw-HWH #10-14 X 3/4 Tf
7:4	32105-15	2	Screw-Machine 1/4-20 X 3/4
7:5	107069	4	Nut-Retainer-Panel 1/4-20
8	109-9342	1	Console.LH Narrow ASM
8:2	109-9345	4	Screw-HWH #10-14 X 3/4 Tf
9	105-1853	1	Clamp-Hose

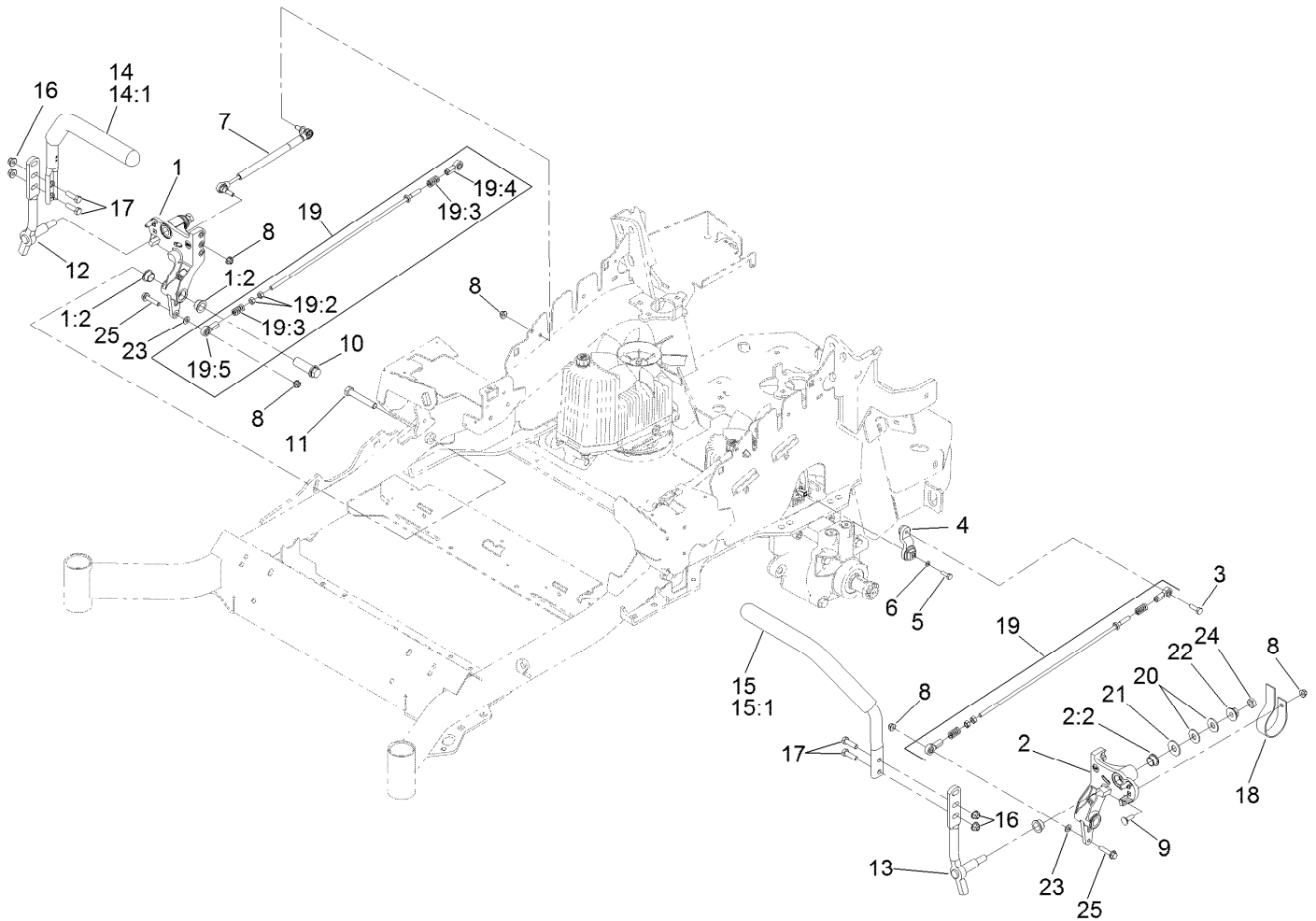

## Motion Control Assembly

Ref.	Part Number	Qty.	Description	Ref.	Part Number	Qty.	Description
1	116-0880	1	RH Motion Control And Bushing ASM	14	109-6589	1	RH Steering Handle ASM
1:2	109-8054	4	Bushing-Flange	14:1	109-5668	1	Grip-Control, Lever
2	116-0881	1	LH Motion Control And Bushing ASM	15	109-6590	1	LH Steering Handle ASM
2:2	109-8054	4	Bushing-Flange	15:1	109-5668	1	Grip-Control, Lever
3	116-0648	2	Screw-HH, Thread Locking ●	16	104-8301	4	Nut-Flange, NI
4	109-4581	2	Arm-Control, Pump	17	323-7	4	Screw-HH
5	9080046	2	Screw-HH ●	18	109-5575	2	Spring-Leaf
6	1-303435	2	Washer-Spring	19	109-8106	2	Front Pump Linkage ASM
7	116-0027	2	Damper-Control, Motion	19:2	3219-2	2	Nut-Hex
8	104-8300	8	Nut-Flange, NI	19:3	1-323245	2	Spring-Compression
9	3230-2	2	Bolt-CARR	19:4	1-633152	1	Balljoint-LH
10	109-5891	2	Hub-Threaded	19:5	1-543017	1	Balljoint-RH
11	325-12	2	Screw-HH	20	109-9505	4	Washer-Spring
12	116-0039	1	Lever-Control Motion, RH	21	3256-6	2	Washer-Flat
13	116-0040	1	Lever-Control Motion, LH	22	32128-56	2	Nut-HF
				23	3256-23	2	Washer-Flat
				24	3218-5	2	Nut-Jam
				25	115-1794	2	Screw-HHF

● Use Pro-Lock, Nut Type (P/N 1-840022, .5ml tube) on threads.

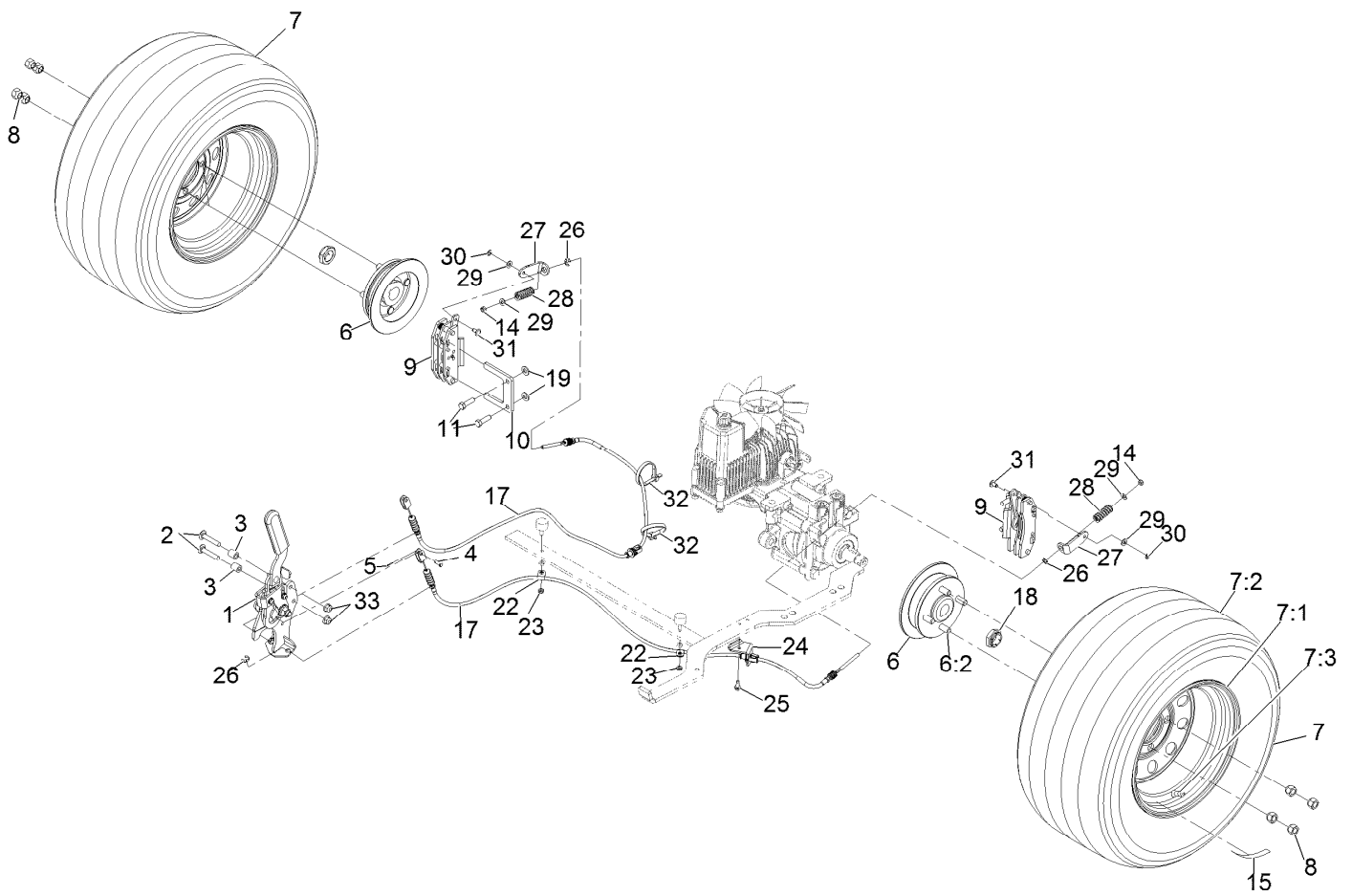

## Rear Wheel and Park Brake Assembly

Ref.	Part Number	Qty.	Description	Ref.	Part Number	Qty.	Description
1	116-7551	1	Brake Handle ASM	14	3296-13	2	Nut-Nyloc 1/4-28
2	116-0629	2	Screw-Carriage 5/16-18 X 1 3/4 Short	15	116-2643	2	Decal-Wheel Nut Torque
3	82-6840	2	Spacer	17	116-8963	2	Cable, Brake
4	60-1730	2	Pin-Clevis	18	116-1399	2	Locknut
5	3272-1	2	Pin-Cotter 1/16 X 1/2	19	3256-24	4	Washer-3/8 Sae
6	116-1746	2	Wheel Hub ASM	22	88-7970	2	Clip
6:2	116-1696	4	Stud-Wheel	23	3296-56	2	Nut-Nyloc 1/4-20 Thin
7	109-8972	2	Wheel And Tire ASM	24	116-6397	1	Bracket-Cable
7:1	1-633993	1	Tire	25	32144-10	1	Screw-HWH 1/4-20 X .62
7:2	109-3156	1	Rim	26	32120-18	4	E-Ring
7:3	232-27	1	Stem-Valve	27	116-6182	2	Bracket-Brake, L
8	242-50	8	Nut-Lug 1/2-20	28	116-6347	2	Spring-Die
9	109-2889	2	Caliper-Brake	29	3256-22	4	Washer-1/4 Sae
10	109-0958	2	Plate-Mount, Brake	30	32151-86	2	E-Ring
11	92-5727	4	Screw-HH 3/8-16 X 1 1/4 Patch Lock	31	116-6348	2	Pin-Brake
				32	3334-945	2	Tie-Cable
				33	104-8300	2	Nut-Nyloc 5/16-18 Flg



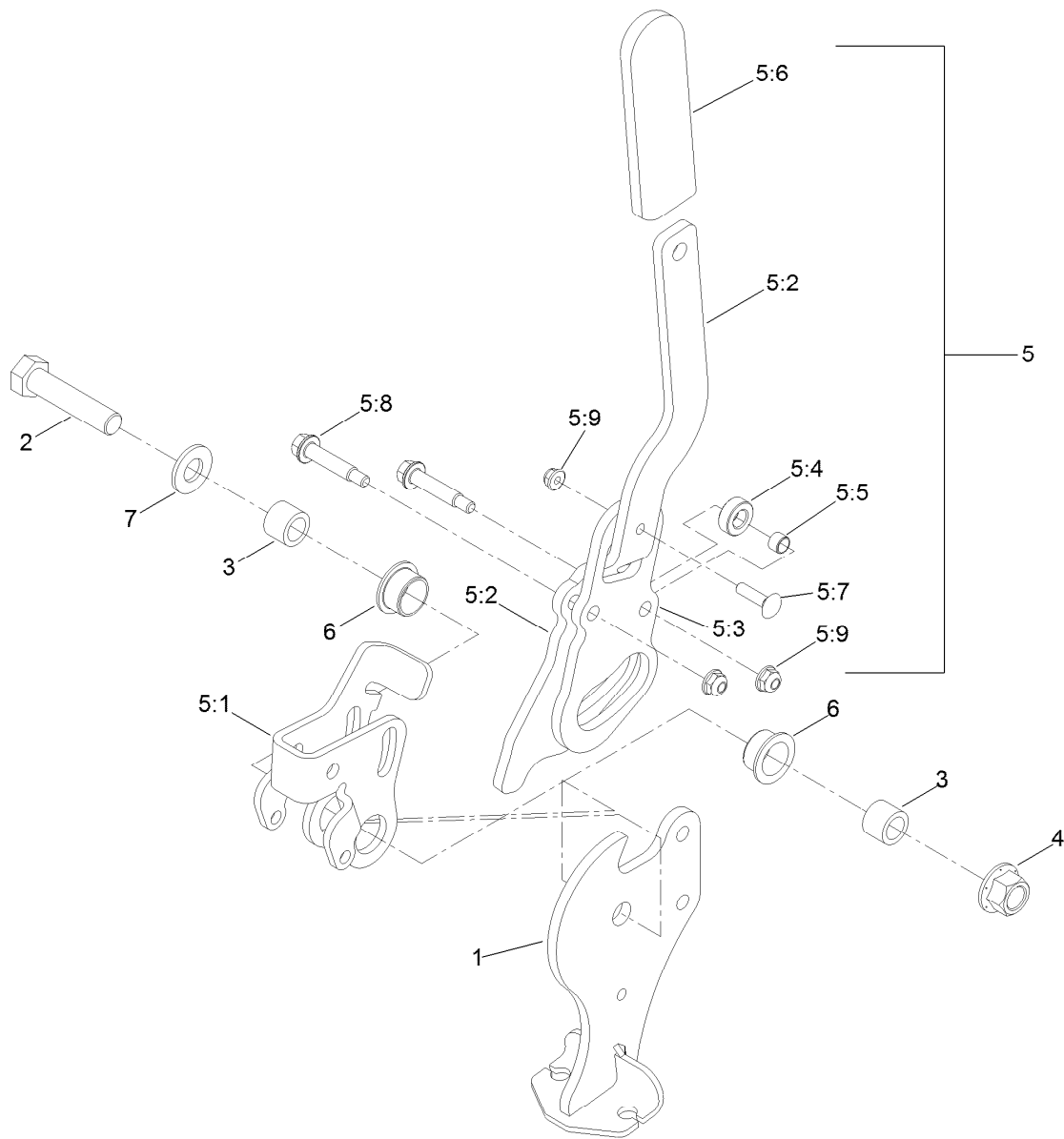

## Parking Brake Handle Assembly No. 116-7551

<i>Ref.</i>	<i>Part Number</i>	<i>Qty.</i>	<i>Description</i>	<i>Ref.</i>	<i>Part Number</i>	<i>Qty.</i>	<i>Description</i>
1	116-7263	1	Pivot-Brake	5:4	116-6846	1	Roller-Brake
2	325-9	1	Screw-HH	5:5	116-6852	1	Bearing-Sleeve
3	116-5384	2	Spacer	5:6	1-633268	1	Grip-Lever
4	99-5107	1	Nut-Lock	5:7	3229-2	1	Screw-CARR
5	116-6860	1	Handle ASM	5:8	116-6876	2	Screw-Shoulder
5:1	116-6856	1	Bellcrank-Brake	5:9	104-7201	3	Nut-HF
5:2	116-6857	1	Handle-Brake	6	109-8054	2	Bushing-Flange
5:3	116-6858	1	Plate-Handle	7	3256-26	1	Washer-Flat

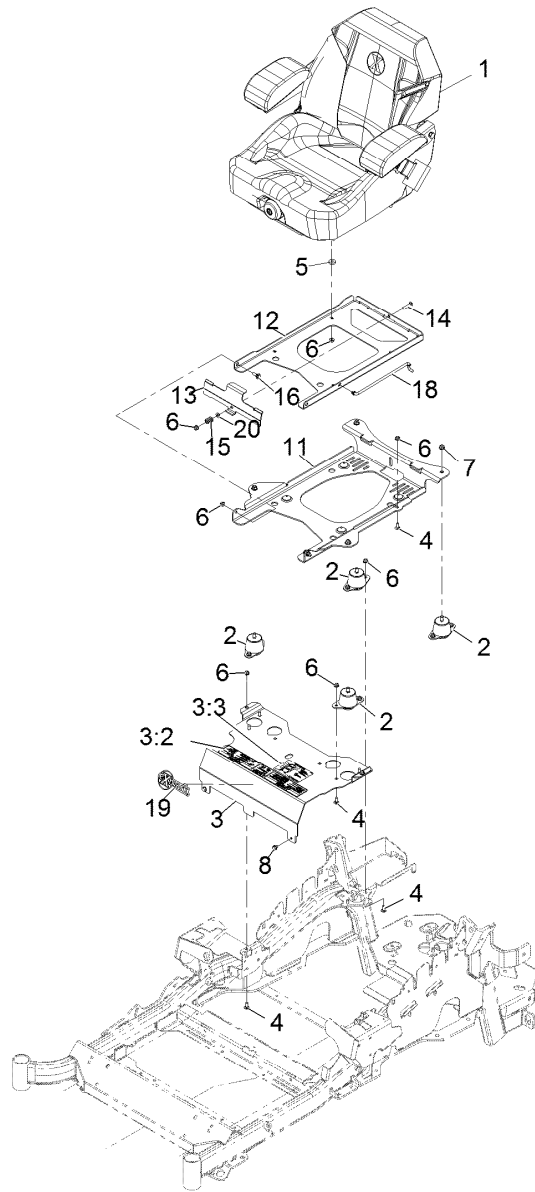

## Seat Assembly

<i>Ref.</i>	<i>Part Number</i>	<i>Qty.</i>	<i>Description</i>	<i>Ref.</i>	<i>Part Number</i>	<i>Qty.</i>	<i>Description</i>
1	116-8912	1	Kit-Suspension Seat	11	116-3860-03	1	Plate-Tilt, Seat Support
2	109-9034	4	Isolator-Seat	12	116-3859-03	1	Plate-Seat, Frame
3	116-2323	1	Mount-Seat	13	109-9881-03	1	Plate-Latch, Seat
3:2	109-7069	1	Decal-Console	14	3230-4	1	Bolt-Carriage 5/16-18 X 1 1/2
3:3	116-0211	1	Decal-Service Aid	15	107-3017	1	Spring-Compression
4	3230-23	11	Bolt-Carriage 5/16-18 X 3/4 Short Neck	16	116-1297	2	Screw-Shoulder
5	26-4840	4	Spacer-Pin, Mounting	18	116-0070	1	Rod-Prop
6	104-8300	18	Nut-Nyloc 5/16-18 Flg	19	103-2883	1	Decal, Exmark Logo
7	104-8301	4	Nut-Nyloc 3/8-16 Flg	20	3256-23	1	Washer-5/16 Sae
8	9266934	2	Screw-HWH 5/16 X 1/2 Tf				

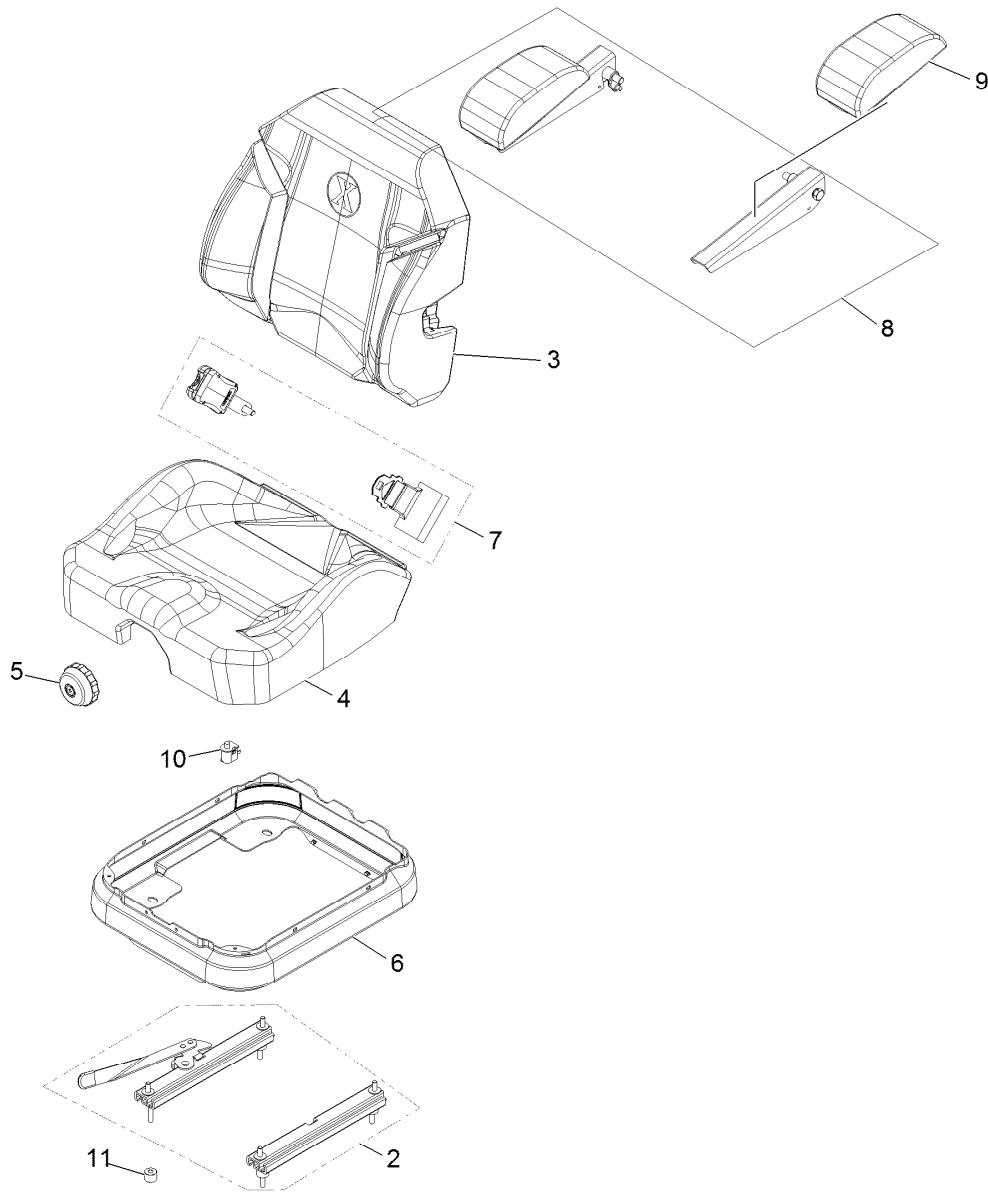

## Seat W/Tracks Assembly No. 116-8912

<i>Ref.</i>	<i>Part Number</i>	<i>Qty.</i>	<i>Description</i>
2	116-8910	1	Seat Track Set
3	116-8908	1	Cover-Back 311463Vn500
4	116-8909	1	Cover-Cushion 311464Vn500
5	116-8911	1	Knob-Adjuster
6	116-5659	1	Cover-Suspension Bellows
7	109-9805	1	Seat Belt Kit
8	116-8906	1	Kit-Arm Rest Set
9	116-8905	1	Kit-Arm Rest Pads
10	82-2190	1	Switch
11	116-9329	4	Spacer

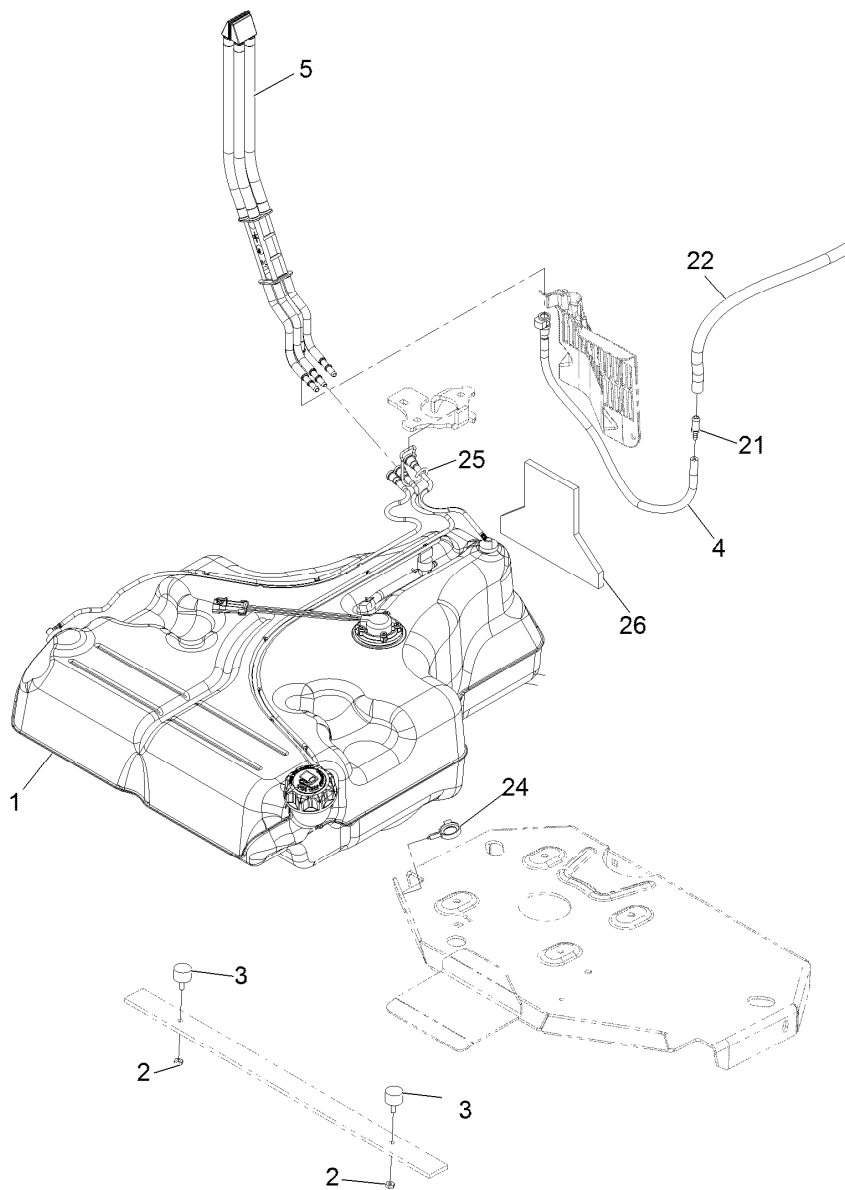

## Fuel Assembly

<i>Ref.</i>	<i>Part Number</i>	<i>Qty.</i>	<i>Description</i>
1	116-3979	1	Fuel Tank ASM
2	3218-1	2	Nut-Jam
3	116-6380	2	Bumper-Rubber (W/ Stud)
4	116-3977	1	Hose ASM
5	109-9491	1	Fuel Manifold Vent ASM
21	98-2952	1	Fitting-Straight
22	116-5087	1	Hose-Fuel
24	105-1853	1	Clamp-Hose
25	116-6005	1	Retainer-Vapor Line
26	126-0224	1	Insulation-Fuel Tank Foam

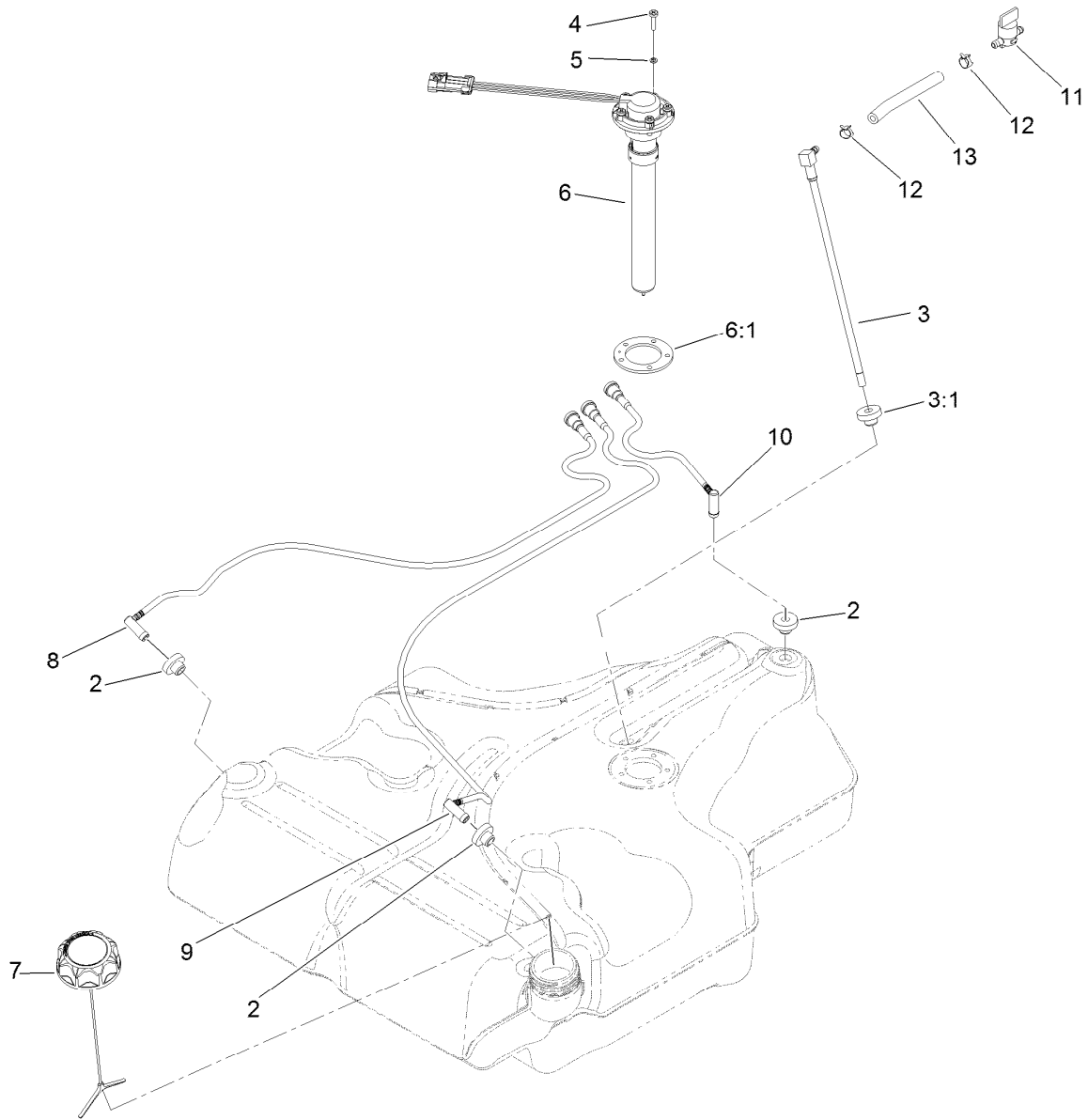

## Fuel Tank Assembly No. 116-3979

<i>Ref.</i>	<i>Part Number</i>	<i>Qty.</i>	<i>Description</i>
2	46-6560	4	Bushing
3	116-2459	1	Fuel Line Kit (With Grommet)
3:1	46-6560	1	Bushing
4	9107944	5	Screw-Pan
5	3253-17	5	Washer-Lock
6	116-0003	1	Sender-Fuel Level
6:1	109-9620	1	Gasket-Sender, Fuel
7	116-1704	1	Cap-Fuel, Ratcheting
8	116-2460	1	RH Vent Line Kit (With Grommet)
9	116-2461	1	LH Vent Line Kit (With Grommet)
10	116-2462	1	Rear Vent Line Kit (With Grommet)
11	1-603770	1	Valve-Fuel
12	2412-98	2	Clamp-Hose
13	109-0650	1	Hose-Fuel

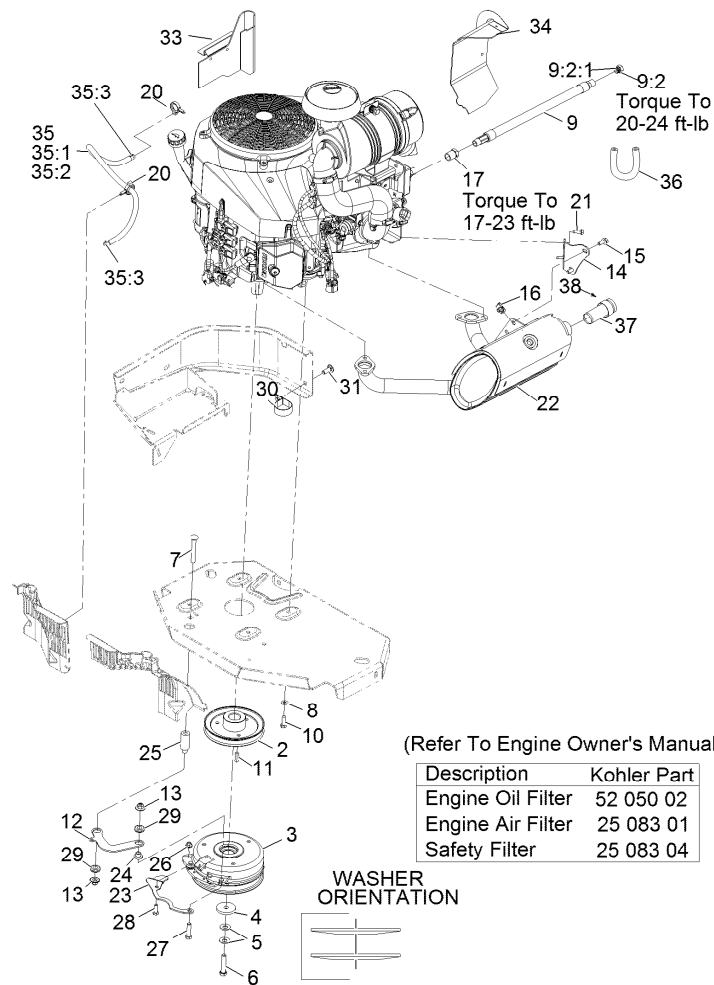

## Engine Assembly

Ref.	Part Number	Qty.	Description	Ref.	Part Number	Qty.	Description
2	109-9905	1	Sheave	22	116-7552	1	Muffler
3	116-1621	1	Clutch Kit	23	116-3331-01	1	Belt-Guide
4	109-6919	1	Washer-Clutch	24	116-3318	1	Spacer
5	1-603610	2	Washer-Spring	25	116-3319	1	Spacer
6	109-9762	1	Screw-HH W/Loctite ●	26	104-8300	1	Nut-Flange, NI
7	3231-42	1	Screw-CARR	27	323-8	1	Screw-HH
8	1-303334	4	Washer-Spring	28	322-4	1	Screw-HH
9	116-5316	1	Oil Drain Hose ASM	29	93-5108	2	Grommet-Rubber
9:2	353-508	1	Plug-HH	30	2412-147	1	Clamp
9:2:1	237-42	1	O-Ring	31	3231-22	1	Screw-CARR
10	33114-025	4	Screw-HH	33	126-0212	1	ASM, RH Baffle
11	1-807259	1	Key	34	126-0215	1	ASM, Rear Baffle
12	116-3317-01	1	Link-Anchor, Clutch	35	126-0231	1	ASM, Fuel Line
13	109-6658	2	Nut-Flange, NI	35:1	109-0284	1	Hose, Fuel Line 29"
14	116-9048	1	Bracket-Muffler	35:2	126-0232	1	Sleeve, Thermal
15	3234-5	2	Screw-HHF	35:3	2412-98	2	Clamp-Hose
16	94-2413	2	U-Nut	36	126-0245	1	Sleeve, Thermal-Short
17	103-1390	1	Bushing	37	126-0268	1	ASM, Spark Arrestor
20	105-1853	2	Clamp-Hose	38	126-0275	1	Screw,HWH Tek 8-18 X 1/2
21	110-3986	2	Screw				

● Use Pro-Lock, Nut Type (P/N 1-840022, .5ml tube) on threads.

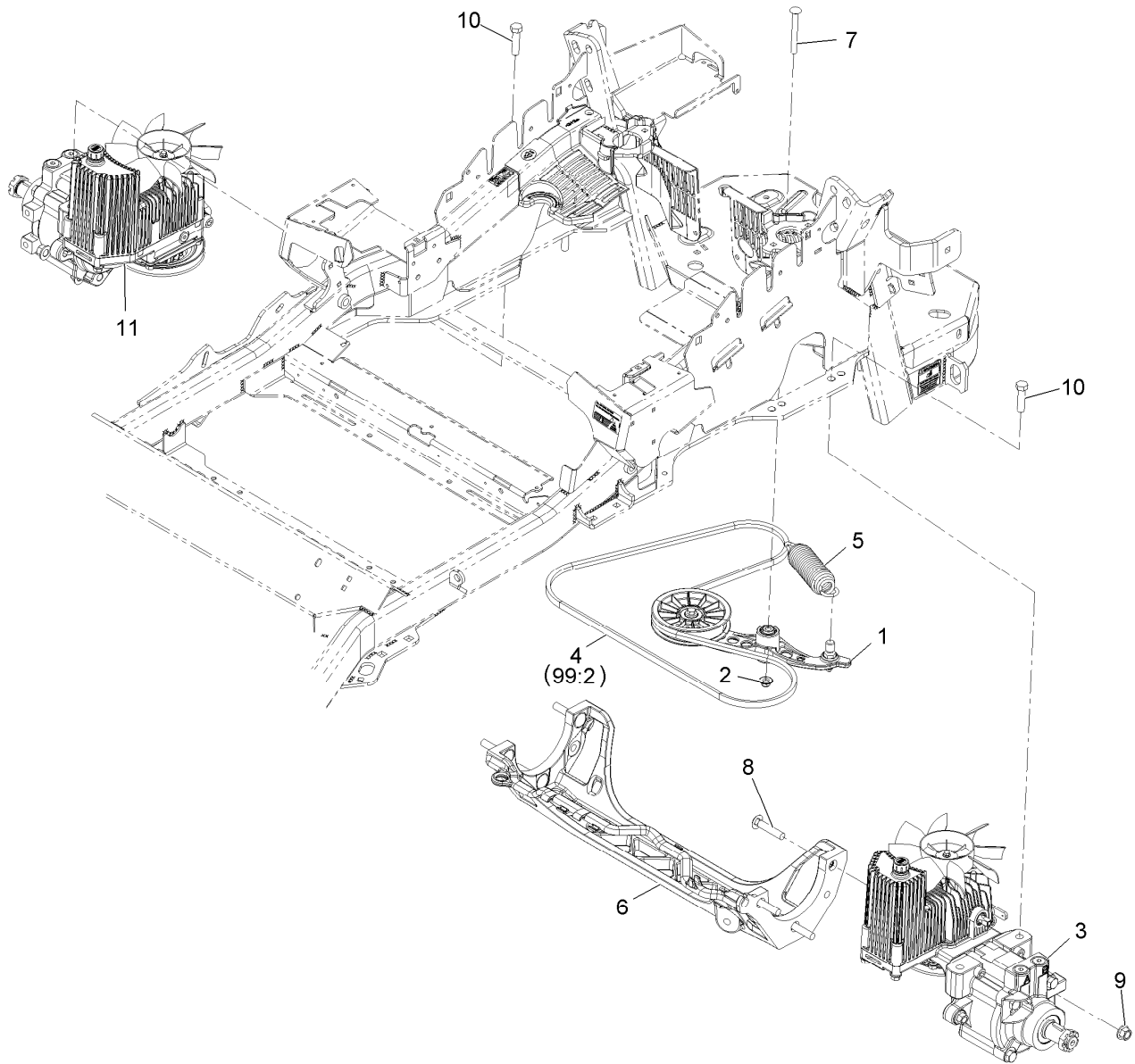

## Hydraulic Assembly

Ref.	Part Number	Qty.	Description	Ref.	Part Number	Qty.	Description
1	116-1255	1	Pump Idler ASM	10	325-8	4	Screw-HH 1/2-13 X 1 1/4
2	109-6658	1	Nut-Nyloc 3/8-16 Flg	11	116-6410	1	RH Hydro ASM (16Cc W/Shock)
3	116-6409	1	LH Hydro ASM (16Cc W/Shock)	99	109-9828	1	Bottle-Oil, 32Oz Hydraulic ●
4	109-3388	1	Belt	99	116-0164	1	Filter-Hydro ●
5	116-6317	1	Spring-Extension	99	116-1218	1	Bottle, Oil 1 Gallon Hydraulic ●
6	109-9375	1	Cradle-Hydro	99	116-3270	1	Kit, Hydro Service ●
7	116-1502	1	Bolt-Carriage Shoulder 3/8-16 X 3 1/2	99:1	109-9828	4	Bottle-Oil, 32Oz Hydraulic ●
8	3233-34	6	Bolt-Carriage 1/2-13 X 2 1/2	99:2	109-3388	1	Belt
9	99-5107	6	Nut-Lock 1/2-13	99:3	116-0164	2	Filter-Hydro ●

● Not illustrated

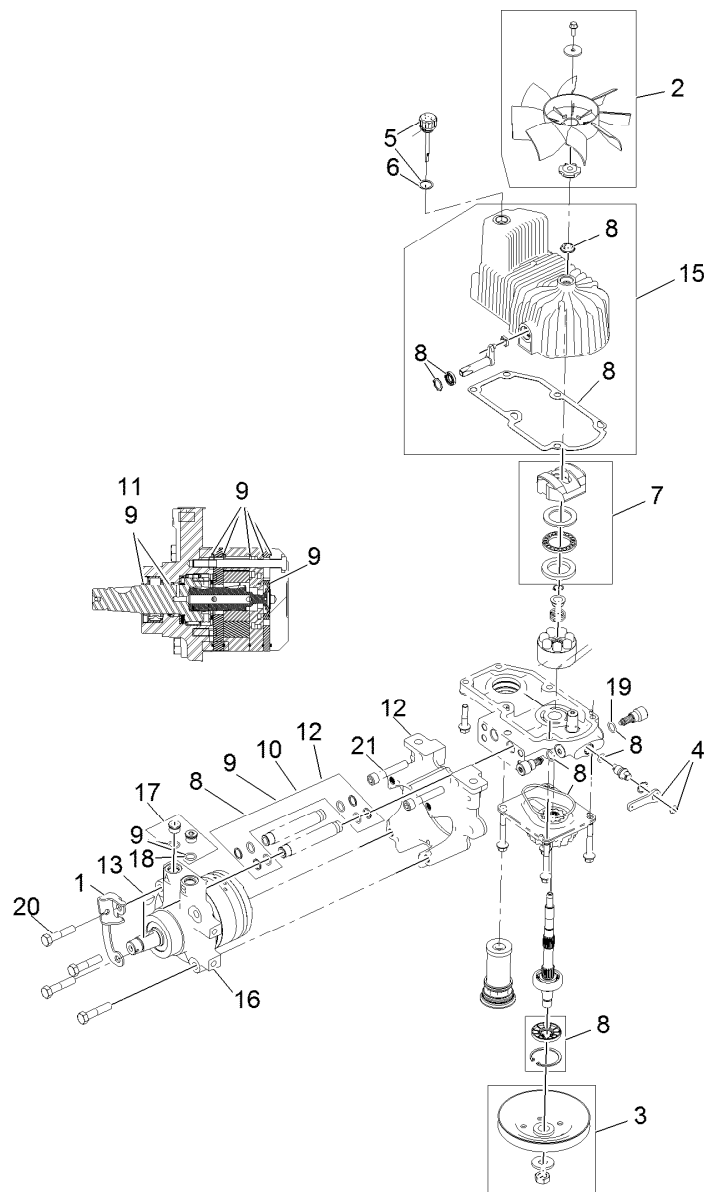

## LH Hydro Assembly No. 116-6409

Ref.	Part Number	Qty.	Description	Ref.	Part Number	Qty.	Description
1	116-6859	1	Bracket-Anchor, Cable	11	116-1371	1	Output Shaft Seal Kit
2	116-0233	1	Fan Kit	12	116-5469	1	Nose Cup-Uht
3	116-0234	1	Pulley Kit	13	3257-42	1	Key-Woodruff 5/16 X 1
4	116-0235	1	Handle-Bypass Valve, Hydro	15	115-3287	1	Housing-Hydro LH
5	116-0236	1	Dipstick-Hydro W/Gasket	16	116-8917	1	Motor-Hydraulic, LH 280Cc
6	116-0237	1	Gasket-Dipstick, Hydro	17	116-7901	1	Magnetic Plugs Service Kit
7	116-1367	1	Swash Block Kit	18	76-1900	2	O-Ring
8	116-1368	1	Pump Seal Kit	19	116-8662	2	O-Ring-Check Valve
9	116-1369	1	Motor Seal Kit	20	116-8974	4	Screw-HH 1/2-20 X 2 1/4
10	116-1370	1	Tube Seal Kit	21	116-8975	2	Screw-HSH 1/2-20 X 2 3/4
				99	116-1373	1	Flow Test Kit ●

● Not illustrated



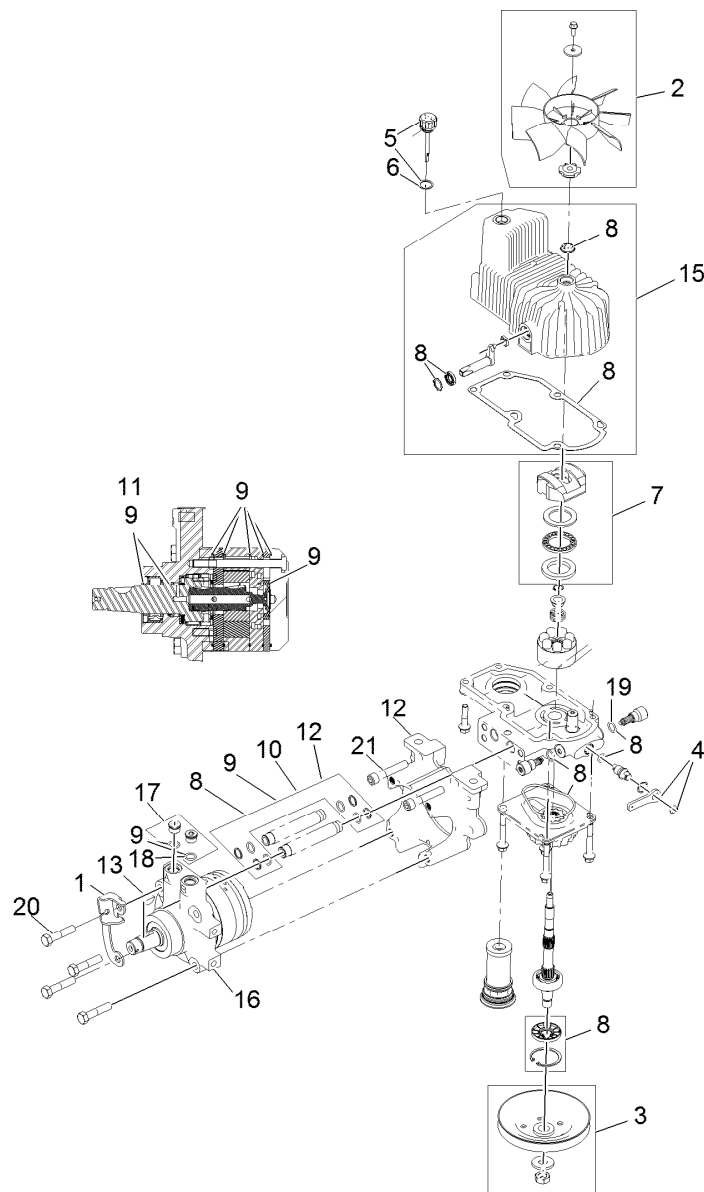

## RH Hydro Assembly No. 116-6410

Ref.	Part Number	Qty.	Description	Ref.	Part Number	Qty.	Description
1	116-6859	1	Bracket-Anchor, Cable	11	116-1371	1	Output Shaft Seal Kit
2	116-0233	1	Fan Kit	12	116-5469	1	Nose Cup-Uht
3	116-0234	1	Pulley Kit	13	3257-42	1	Key-Woodruff 5/16 X 1
4	116-0235	1	Handle-Bypass Valve, Hydro	15	116-3288	1	Housing-RH
5	116-0236	1	Dipstick-Hydro W/Gasket	16	116-8918	1	Motor-Hydraulic, RH 280Cc
6	116-0237	1	Gasket-Dipstick, Hydro	17	116-7901	1	Magnetic Plugs Service Kit
7	116-1367	1	Swash Block Kit	18	76-1900	2	O-Ring
8	116-1368	1	Pump Seal Kit	19	116-8662	2	O-Ring-Check Valve
9	116-1369	1	Motor Seal Kit	20	116-8974	4	Screw-HH 1/2-20 X 2 1/4
10	116-1370	1	Tube Seal Kit	21	116-8975	2	Screw-HSH 1/2-20 X 2 3/4
				99	116-1373	1	Flow Test Kit ●

● Not illustrated

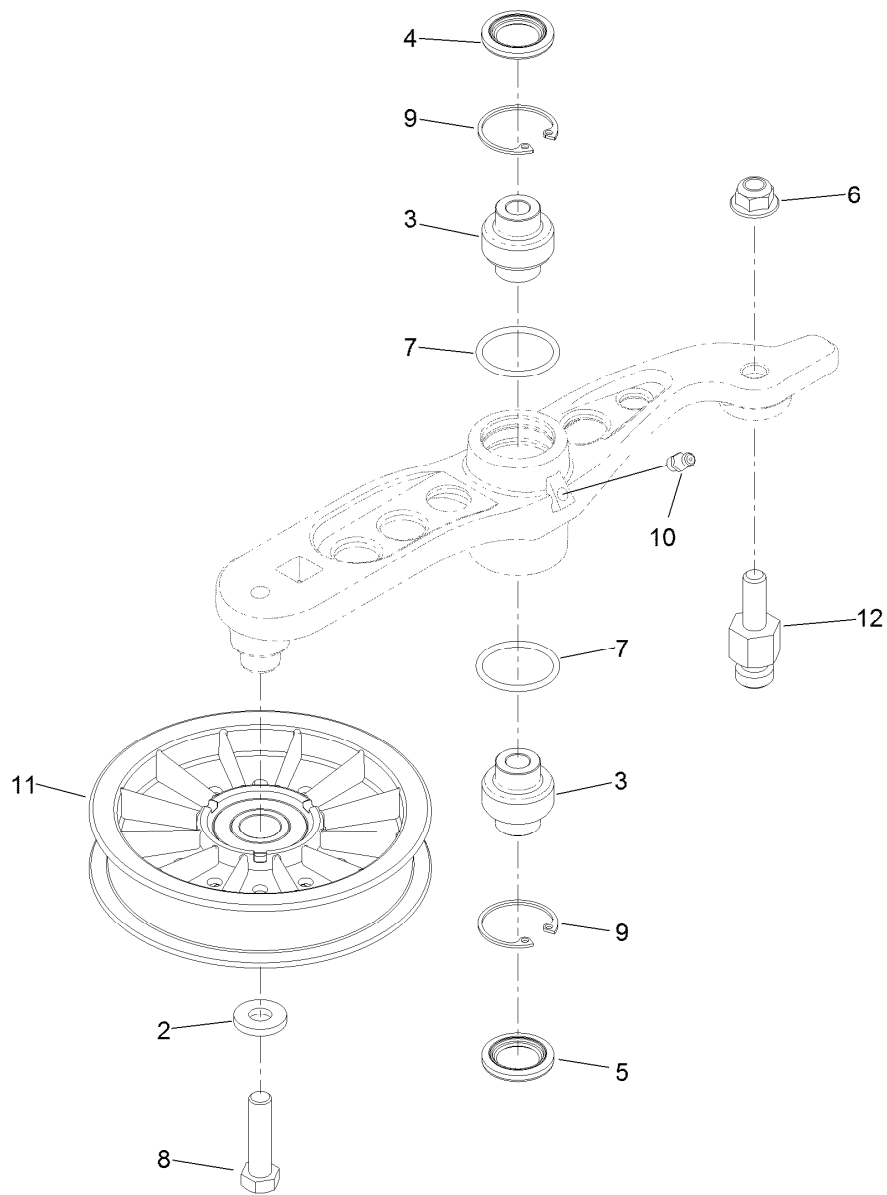

## Pump Idler Assembly No. 116-1255

Ref.	Part Number	Qty.	Description
2	43-0940	1	Spacer
3	103-3504	2	Bearing-Spherical
4	103-3505	1	Seal-Double Lip
5	103-3506	1	Seal-Single Lip
6	109-6658	1	Nut-Flange, NI
7	106-7159	2	O-Ring
8	323-8	1	Screw-HH
9	32120-10	2	Ring-Snap
10	302-19	1	Fitting-Grease
11	109-8076	1	Pulley-Idler
12	116-3467	1	Pin-Spring, Anchor

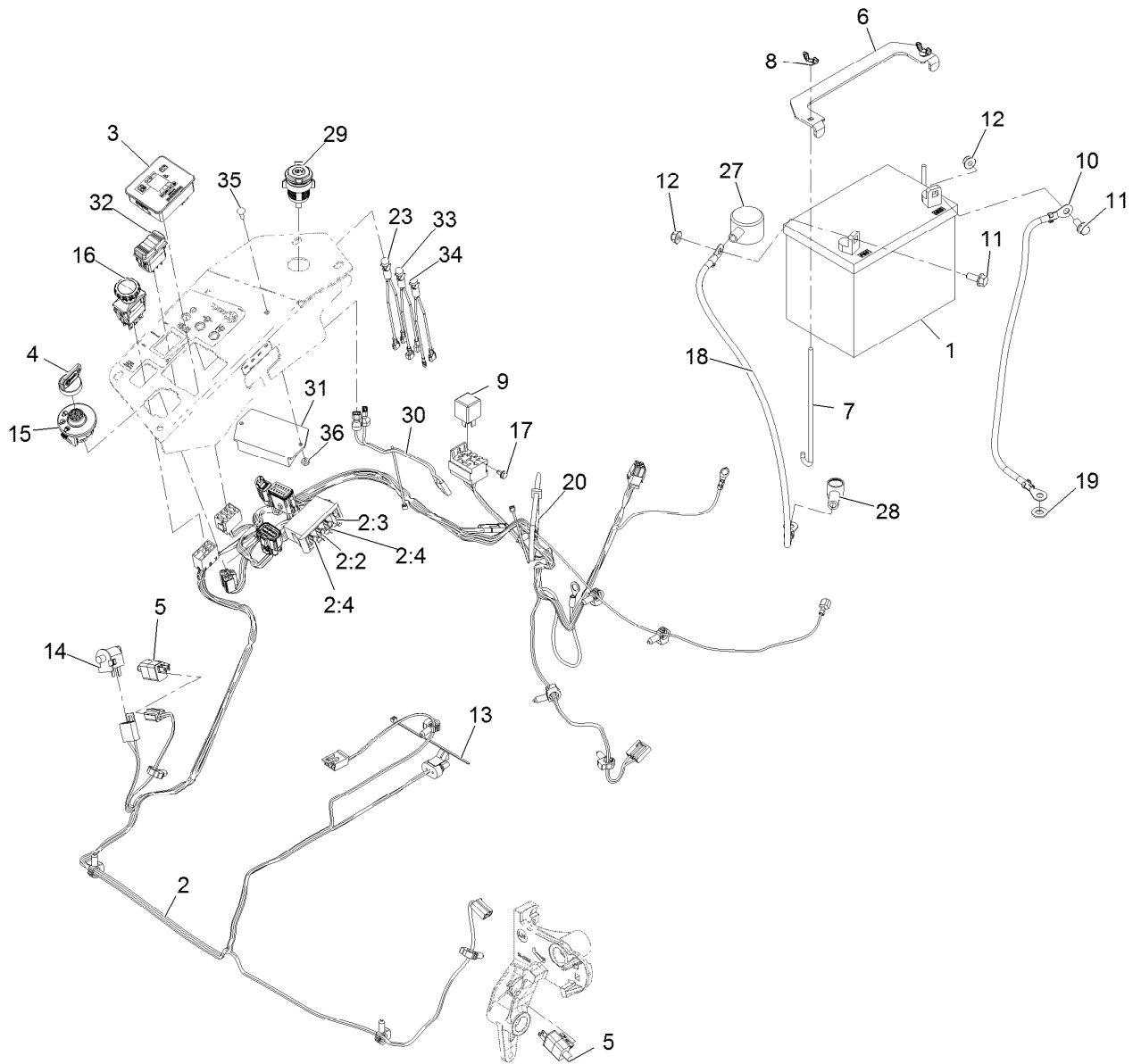

## Electrical Assembly

Ref.	Part Number	Qty.	Description	Ref.	Part Number	Qty.	Description
1		1	Battery ●■	15	117-2221	1	Switch-Ignition
2	116-8765	1	Harness-Wire,Kohler E/Gov	16	116-0124	1	Switch-PTO, 10A
2:2	218-578	1	Fuse-Blade, 10 Amp	17	104-2065	1	Screw-HWH #10-24 X 3/8
2:3	109355	1	Fuse-Blade, 15 Amp	18	115-3864	1	Cable-Battery, Positive
2:4	109102	2	Fuse-Blade, 25 Amp	19	3256-24	1	Washer-3/8 Sae
3	117-3882	1	Fuel/Hour Meter ASM	20	1-303335	1	Tie-Cable 7 15/16 (Large)
4	1-603511	1	Key-Ignition	23	1-643267	1	Indicator-Red Led
4	103-2106	1	Key-Exmark Logo	27	109-2407	1	Insulator-Battery
5	110-6765	2	Switch-Single Pole No	28	1-543393	1	Insulator-Solenoid
6	116-0042-03	1	Strap-Tie Down, Battery	29	109-9376	1	Receptacle, 12V
7	1-633651	2	Bolt-Holddown	30	109-9693	1	Harness, Receptacle 12V
8	1-543792	2	Wingnut-Nyloc 1/4-20	31	116-8660	1	Controller-Throttle, Electronic
9	1-643275	1	Relay-12Vdc 40 Amp	32	116-9669	1	Switch, Rocker
10	114-1218	1	Cable-Battery, Negative	33	116-9651	1	Light,Led-Red
11	3234-5	2	Screw-HH Flg 5/16-18 X 3/4	34	116-9652	1	Light,Led-Red
12	104-8300	2	Nut-Nyloc 5/16-18 Flg	35	3229-34	2	Screw-CARR
13	1-303287	3	Tie-Cable 5 1/2 (Small)	36	3296-2	2	Nut-Nyloc #10-24
14	82-2190	1	Switch				

● Obtain locally.

■ Not serviced separately

**Notes:**

**Notes:**

**Notes:**

# EXMARK® MAINTENANCE

## MAXIMIZE THE PERFORMANCE OF YOUR EXMARK.

### **4-CYCLE PREMIUM ENGINE OIL**

Part No. 116-3373

Both SAE 30 and SAE 10W-30 in one bottle.

Contains increased levels of zinc and phosphorus for better lubricity.

No Viscosity Index Improvers that tend to shear down in high heat.

Synthetic formulation.

Gas & Diesel compatible.

Anti-corrosion additives.

API 'SL' and JASO rated with wet clutch compatibility for other machines.

### **PREMIUM HYDRO OIL**

Part No. 109-9828

Commercial quality for tough, high-heat conditions.

Designed specifically for zero-turn mower hydraulic systems.

Superior shear resistance under heavy loads.

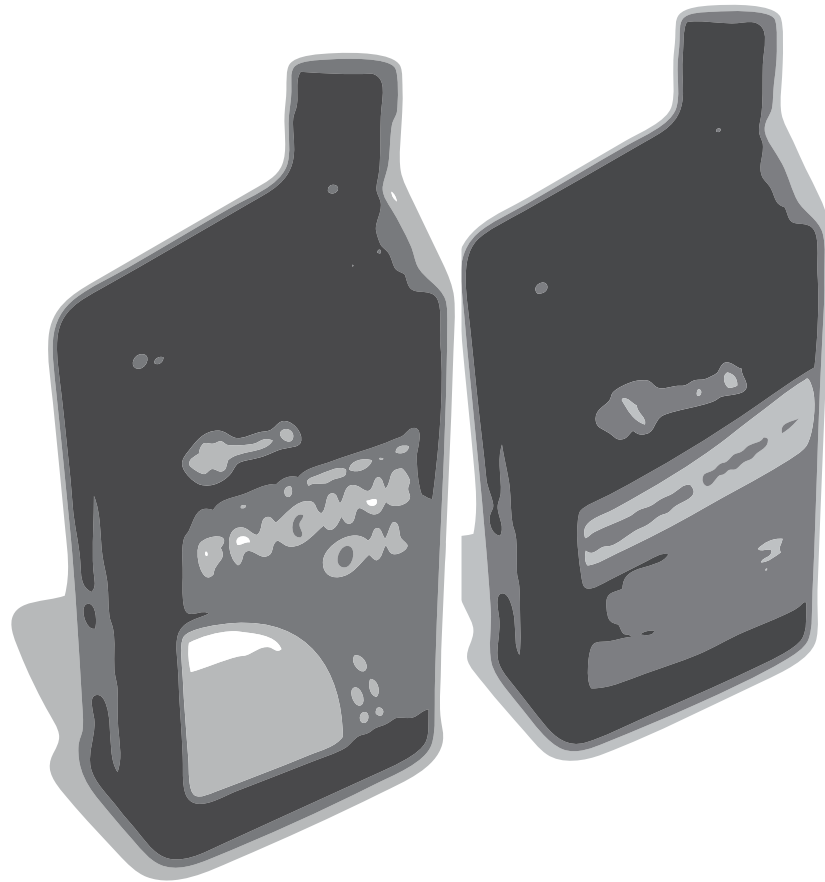

Available from your local Exmark dealer. Find your closest dealer at [exmark.com](http://exmark.com)

## EXMARK ACCESSORIES AND OPTIONS\*

### MID-MOUNT RIDING ACCESSORIES AND OPTIONS

CUSTOM RIDE SEAT SUSPENSION SYSTEM	OPERATOR CONTROLLED DISCHARGE
FULL SUSPENSION SEAT	SUN SHADE
DECK LIFT ASSIST KIT	TRASH CONTAINER
HITCH KIT	TURF STRIPER
LIGHT KIT	ULTRA VAC COLLECTION SYSTEM
12V POWER PORT	ULTRA VAC QUICK DISPOSAL SYSTEM
MICRO-MULCH SYSTEM	

### OUT-FRONT RIDING ACCESSORIES AND OPTIONS

CUSTOM RIDE SEAT SUSPENSION SYSTEM	SNOW BLADE
DUAL-TAIL WHEEL	SNOWBLOWER
FLOOR PAN EXTENDER	SUN SHADE
HITCH KIT	TRASH CONTAINER
LIGHT KIT	ULTRA VAC COLLECTION SYSTEM
MICRO-MULCH SYSTEM	ULTRA VAC QUICK DISPOSAL SYSTEM
ROLL OVER PROTECTION SYSTEM (ROPS)	WEATHER CAB

### WALK-BEHIND ACCESSORIES AND OPTIONS

GRASS CATCHER	TURF STRIPER
MICRO-MULCH SYSTEM	STANDON

\*Some accessories and options not available for some models.

Place Model No. and Serial No.  
Label Here (Included in the Literature  
Pack) or Fill in Below

Model No. \_\_\_\_\_

Serial No. \_\_\_\_\_

Date Purchased \_\_\_\_\_

Engine Model No. and Spec. No. \_\_\_\_\_

Engine Serial No. (E/No) \_\_\_\_\_

© 2013 Exmark Mfg. Co., Inc.  
Industrial Park Box 808  
Beatrice, NE 68310  
All Rights Reserved

Part No. 4501-417 Rev. A  
(402) 223-6300  
Fax (402) 223-5489  
Printed in the USA.

