

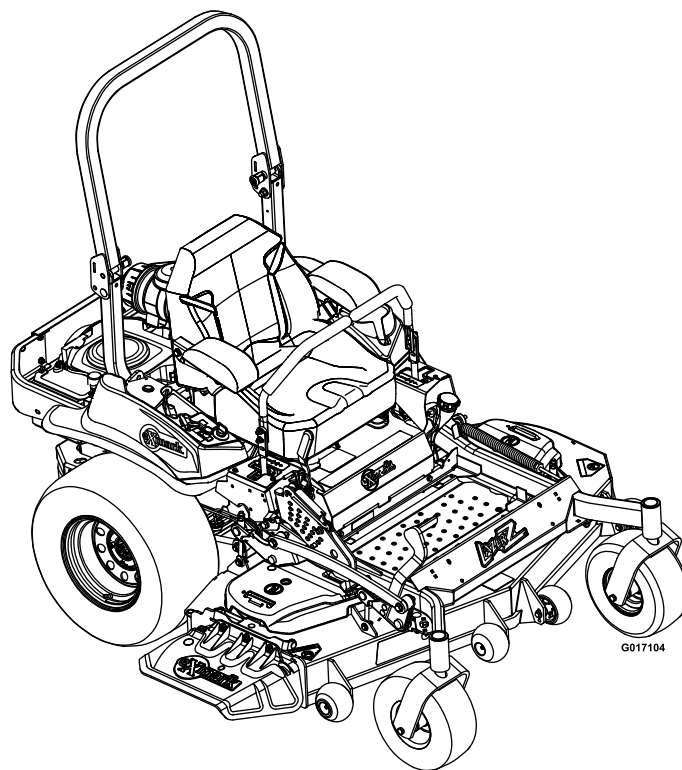

LAZER Z[®] X-SERIES

Model No. LZX980KC726—Serial No. 31300000 and Up

Picture below may not reflect actual product.



Parts Manual

Part No. 4501-416 Rev. A

Ordering Replacement Parts

To order replacement parts, please supply the part number, the quantity, and the description of each part desired.

Understanding Reference Numbers

Each identified part in an illustration has a reference number. The reference number for a part also appears in the parts list, along with other information about the part.

This catalog uses two special reference number formats, one to indicate parts in a service assembly and another to indicate the quantity of a given part in an illustration.

Service Assembly Reference Numbers

Parts in service assemblies have reference numbers in the form a:b. The a represents the reference number of the entire service assembly and the b represents a sequential number unique to each part within the service assembly.

For example, a wheel assembly might be identified by reference number 6, the tire by 6:1, the valve by 6:2, and the wheel by 6:3. When you order the assembly identified by reference number 6, you receive all parts identified by reference numbers 6:1, 6:2, and 6:3. However, you may also order any part individually. Reference numbers of this type appear in illustration and in parts lists.

Reference Numbers Indicating Quantity

In an illustration, if a reference number indicates more than one part, the reference number has the form nX y. The n represents the quantity of the part, the X is the multiplication symbol, and the y represents the reference number.

For example, in an illustration, the reference number 2X 37 means that two of the parts identified by reference number 37 are indicated.

List of Abbreviations

AR: as required	HJ: hex jam	PRH: phillips round head
ASM: assembly	HLH: hex lag head	PTH: phillips truss head
BBC: blade brake control	HOC: height-of-cut	PTO: power-take-off
BHTF: button head thread forming	HSBH: hex socket button head	RH: right hand
CARR: carriage	HSFH: hex socket flat head	ROPS: roll-over protection system
CCW: counter clockwise	HSH: hex socket head	RRB: rear roller brush
CW: clockwise	HWH: hex washer head	SFH: slotted fillister head
DEG: degrees	HWHTF: hex washer head thread forming	SHH: slotted hex head
DPA: Dual Point Adjustment	HYD: hydraulic	SHWH: slotted hex washer head
ECM: electronic control module	LH: left hand	SPH: slotted pan head
EXT: external	LP: Liquefied Petroleum Gas	SQH: square head
FH: flat head	LPG: Liquefied Petroleum Gas	SRH: slotted round head
GA: gauge	NI: nylon insert	STD: standard
HD: heavy-duty	NPTF: national pipe thread fine	TAP: self tapping
HF: hex flange	PFH: phillips flat head	TTH: torx truss head
HH: hex head	PPH: phillips pan head	
HHF: hex head flange	PPHTF: phillips pan head thread forming	
HHFTF: hex head flange thread forming		

Touch Up Paint

Exmark black touch up spray paint – gloss black.

Exmark red touch up paint (spray paint – P/N 1-850337 - .6 oz liquid bottle – P/N 103-9140).

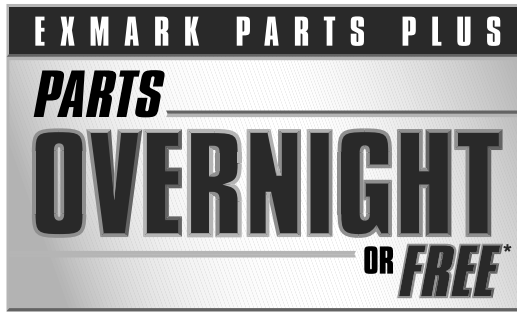

If your Exmark dealer does not have the Exmark part in stock, Exmark will get the parts to the dealer the next business day or the part will be FREE Guaranteed!! (Some restrictions apply. See your participating Exmark Dealer for details.)

Contents

Complete Deck Assembly.....	4
Deck Assembly.....	5
Deck W/Decals Assembly No. 109-9133.....	6
Deck Idler Assembly No. 116-3755.....	7
Cutter Housing Assembly No. 103-9539.....	8
Main Frame Assembly.....	9
Roll-Over Protection System Assembly No. 116-0230.....	10
Caster Wheel and Fork Assembly.....	11
Deck Lift Assembly.....	12
Height-of-Cut Assembly No. 109-7438.....	13
Control Assembly.....	14
Motion Control Assembly.....	15
Rear Wheel and Park Brake Assembly.....	16
Parking Brake Handle Assembly No. 116-7551.....	17
Seat Assembly.....	18
Seat W/Tracks Assembly No. 116-8912.....	19
Fuel Tank Mounting Assembly.....	20
Fuel Tank Assembly No. 116-3979.....	21
Engine Assembly.....	22
Hydraulic Assembly.....	23
LH Hydro Assembly No. 116-6409.....	24
RH Hydro Assembly No. 116-6410.....	25
Pump Idler Assembly No. 116-1255.....	26
Electrical Assembly.....	27

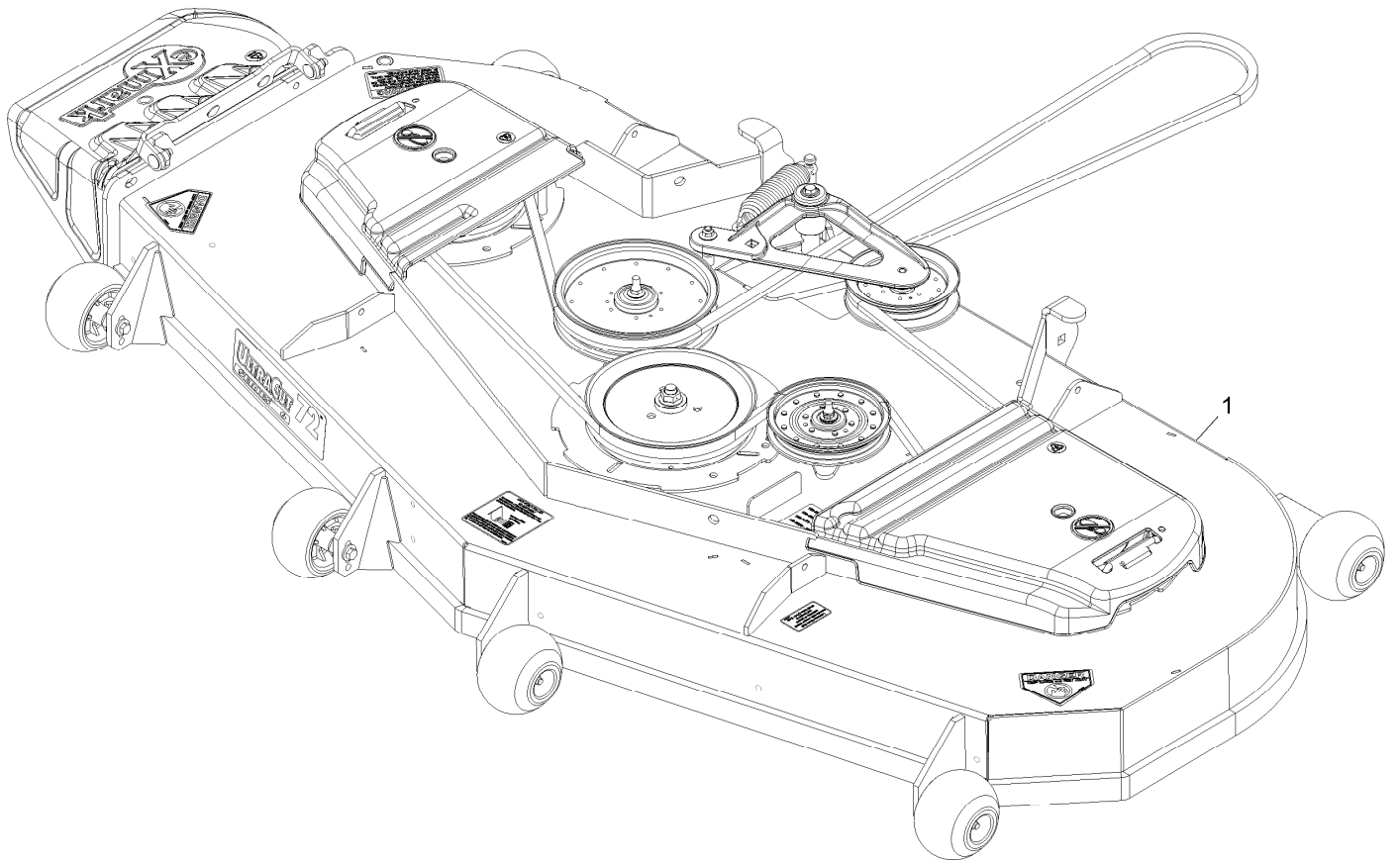

Complete Deck Assembly

<i>Ref.</i>	<i>Part Number</i>	<i>Qty.</i>	<i>Description</i>
1	109-9649	1	Complete Deck ASM-726

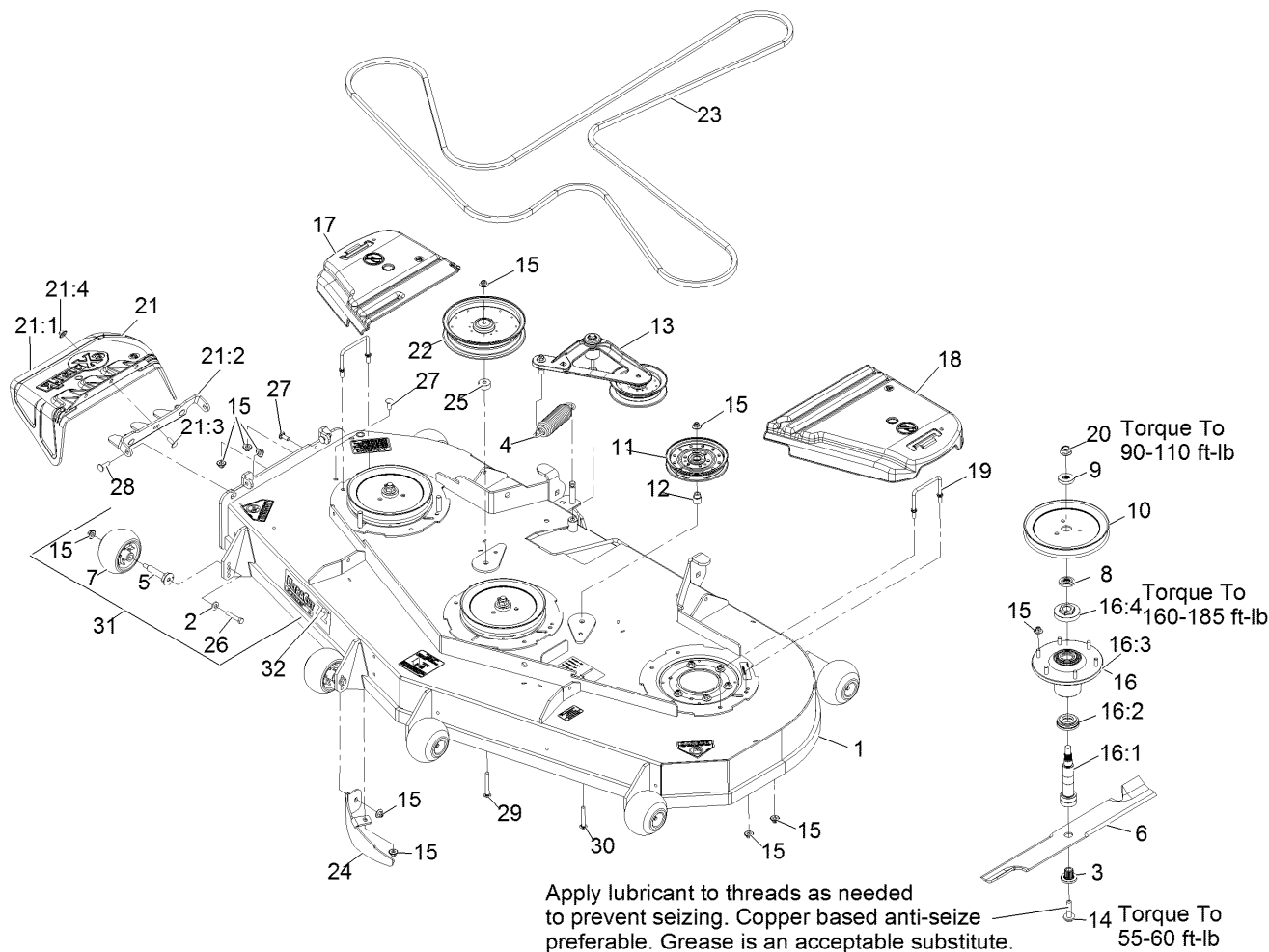

Deck Assembly

Ref.	Part Number	Qty.	Description	Ref.	Part Number	Qty.	Description
1	109-9133	1	Deck W/ Decals ASM-72	16:2	103-9539	1	ASM,Cutter Housing
2	98-5975	6	Washer-Spring Disc 3/8	16:3	109-0916	1	Nut, Spindle 7/8-14
3	103-3037	3	Bushing,Splined	16:4	109-6881	1	Spindle,Double Spline ■
4	116-6317	1	Spring-Extension	17	116-0094	1	Cover-Belt, RH
5	109-9851	6	Axle, Anti-Scalp Roller	18	109-6938	1	Cover-Belt, LH
6	103-6384	3	Blade, Solid 24.5 (.94 Hole)	19	109-6982	2	Wireform-Cover
6	103-6404	3	Blade, Notched 24.5 (.94 Hole)	20	109-7033	3	Nut-Flange 5/8-18 Centerlock
6	103-6394	3	Blade, Mulch 24.5 (.94 Hole) ●	21	109-7188	1	ASM,Discharge Chute
6	116-5171	3	Blade-Extreme 2, 24.50"	21:1	109-2738	1	Chute,Discharge
6	103-6389	3	Blade, Low Lift 24.5 (.94 Hole)	21:2	109-8675-01	1	Bracket,Discharge Chute
7	103-8415	6	Roller,Anti-Scalp	21:3	3231-22	3	Bolt-Carriage 3/8-16 X 1
8	103-9522	3	Spacer,Splined Stepped	21:4	109-6658	3	Nut-Nyloc 3/8-16 Flg
9	103-9523	3	Spacer,Splined	22	109-8590	1	Pulley-Idler
10	109-2180	3	Sheave,Blade Drive 9.00	23	109-9023	1	Belt,V-5V X 219.00"
11	116-4667	1	Idler-Pulley, Flat	24	116-5834-01	1	Baffle-Dogleg, Lz72
12	1-633456	1	Bushing,Idler	25	103-2956	1	Spacer-Idler
13	116-3755	1	Deck Idler ASM	26	3211-46	6	Screw-HH 3/8-24 X 2 Gr8
14	109-9220	3	Screw-Sems 1/2-20 X 2.19	27	3231-22	2	Bolt-Carriage 3/8-16 X 1
15	109-6658	34	Nut-Nyloc 3/8-16 Flg	28	3231-28	2	Bolt-Carriage 3/8-16 X 1 1/4
16	109-6917	3	ASM,Spindle Housing	29	3231-42	1	Bolt-Carriage 3/8-16 X 3
16:1	103-9504	1	Guard,Bottom	30	3231-44	1	Bolt-Carriage 3/8-16 X 2 1/2
				31	109-2098	6	Kit, Antiscalp
				32	109-9440	1	Decal,Ultracut 72 Series 6

● Requires installation of mulch kit for proper mulching. See your Exmark dealer for details.

■ Apply Mobil HTS grease (P/N 103-5217 1.5 oz packet) (or a food-grade anti-seize). See operator s manual for locations.

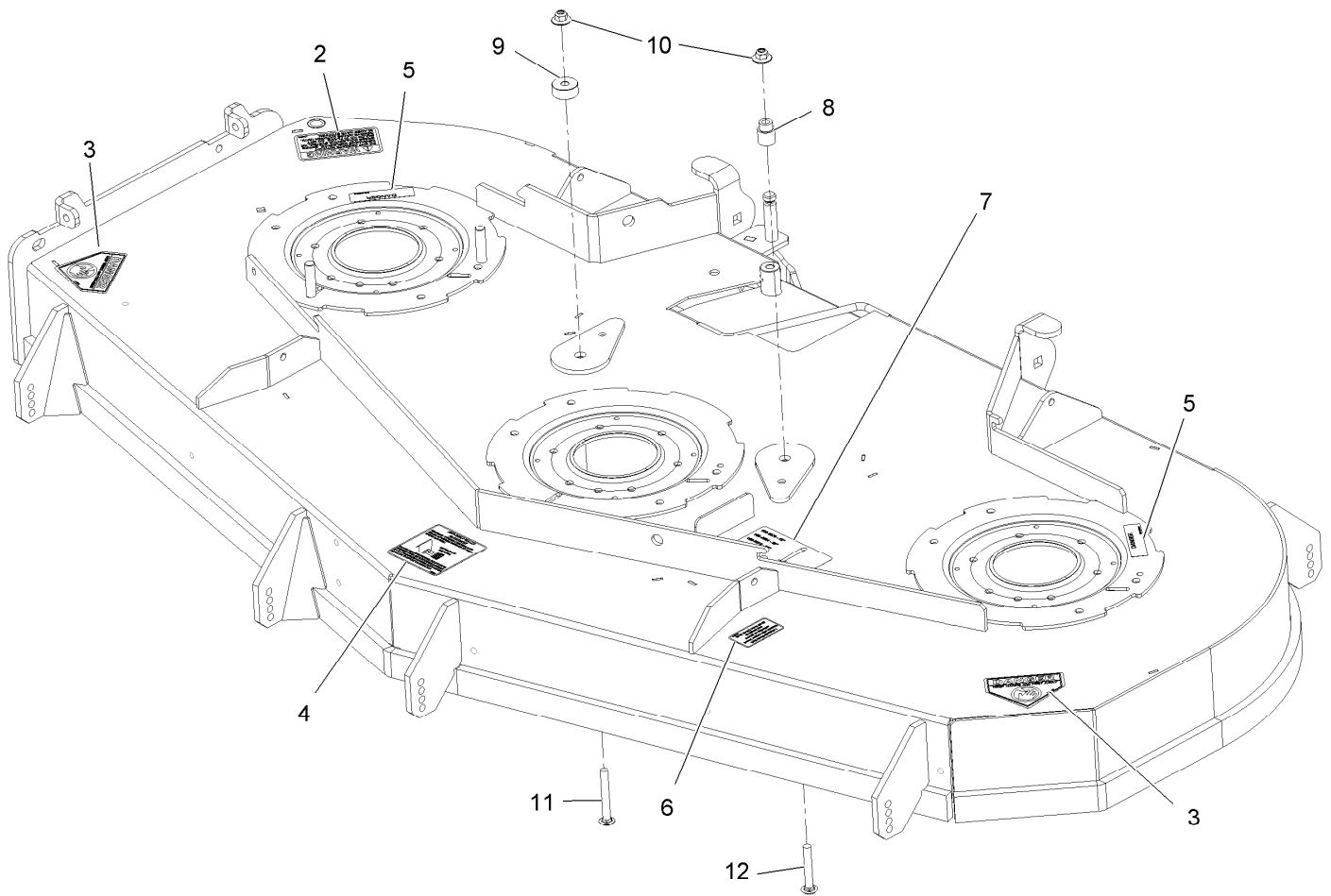

Deck W/Decals Assembly No. 109-9133

<i>Ref.</i>	<i>Part Number</i>	<i>Qty.</i>	<i>Description</i>
2	1-303508	1	Decal-Warning, Discharge
3	1-403005	2	Decal-Danger
4	1-633922	1	Decal,Antiscalp
5	98-5954	2	Decal-Cover, Missing
6	109-3148	1	Decal,Bolt Torque
7	109-9361	1	Decal,Belt Routing
8	1-633456	1	Bushing,Idler
9	103-2956	1	Spacer-Idler
10	109-6658	2	Nut-Nyloc 3/8-16 Flg
11	3231-42	1	Bolt-Carriage 3/8-16 X 3
12	3231-44	1	Bolt-Carriage 3/8-16 X 2 1/2

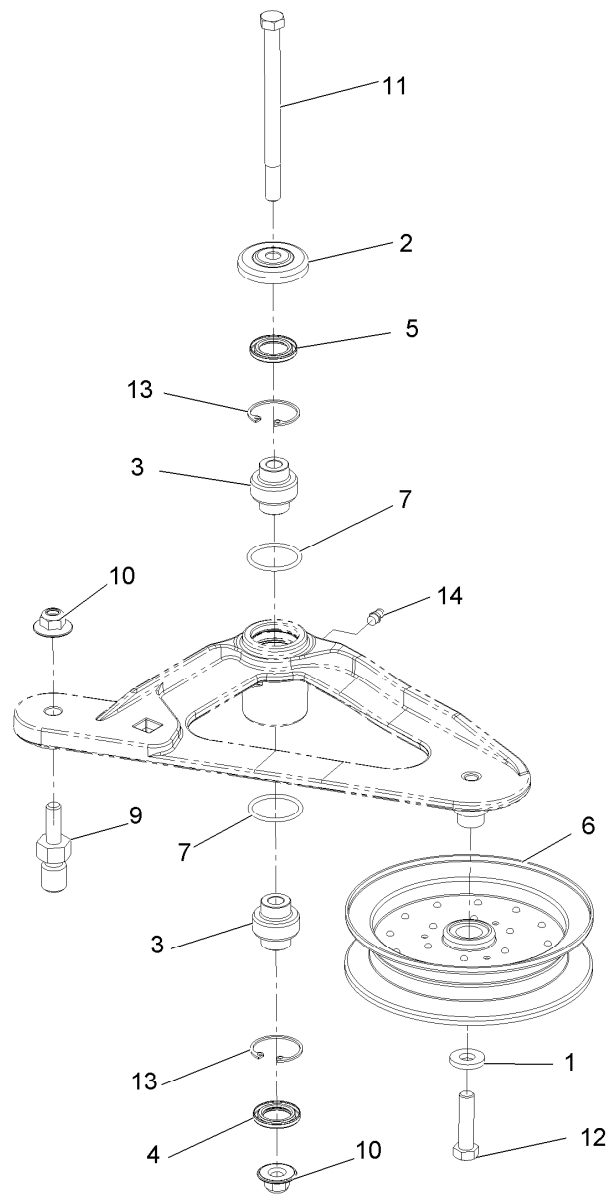

Deck Idler Assembly No. 116-3755

<i>Ref.</i>	<i>Part Number</i>	<i>Qty.</i>	<i>Description</i>
1	43-0940	1	Spacer
2	103-2916	1	Guard-Top
3	103-3504	2	Bearing-Spherical
4	103-3505	1	Seal-Double Lip
5	103-3506	1	Seal-Single Lip
6	116-4668	1	Idler-Pulley, Flanged
7	106-7159	2	O-Ring
9	116-3467	1	Pin-Spring, Anchor
10	109-6658	2	Nut-Nyloc 3/8-16 Flg
11	109-7409	1	Screw-Shoulder 3/8-16 X 5
12	323-8	1	Screw-HH 3/8-16 X 1 1/2
13	32120-10	2	Ring-Retaining
14	302-19	1	Zerk-1/4-28 Str

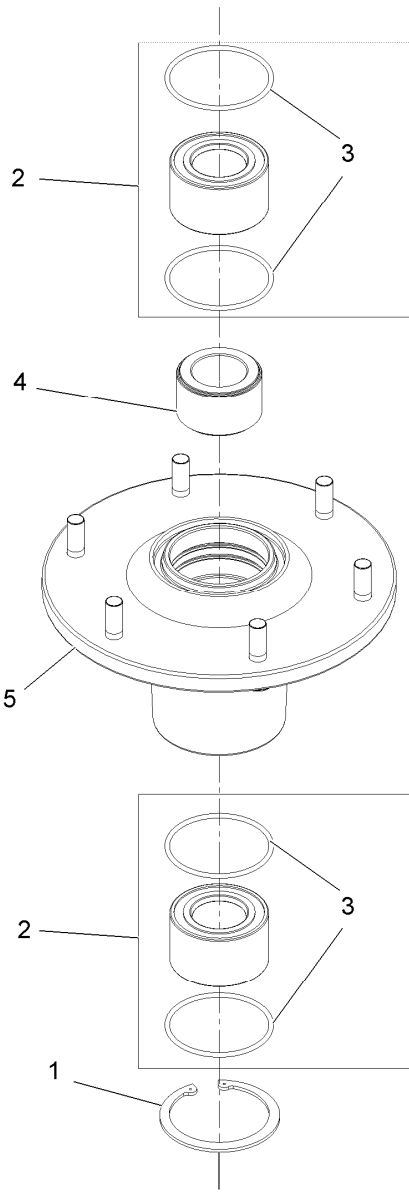

Cutter Housing Assembly No. 103-9539

<i>Ref.</i>	<i>Part Number</i>	<i>Qty.</i>	<i>Description</i>
1	92-5581	1	Ring-Retaining
2	109-2064	1	ASM, Bearing W/Orings
3	103-5895	4	O-Ring
4	103-9506	1	Spacer, Bearing
5	109-0764	1	ASM, Housing W/Studs

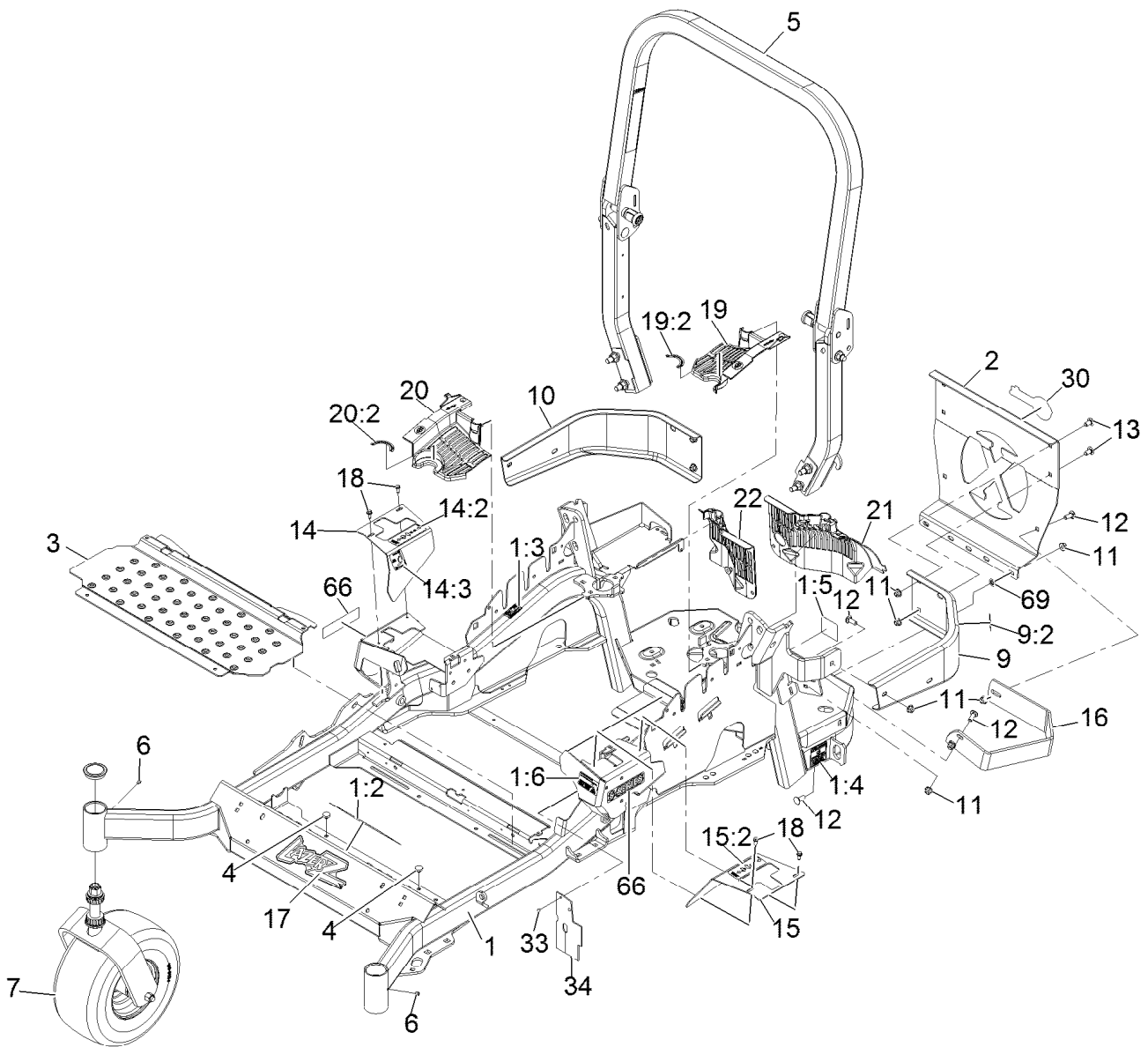

Main Frame Assembly

Ref.	Part Number	Qty.	Description	Ref.	Part Number	Qty.	Description
1	116-5904	1	Mainframe ASM	14:2	109-7232	1	Decal-Motion Control
1:2	103-2076	2	Decal-Caution	14:3	116-5944	1	Decal-Park Brake
1:3	116-3303	1	Decal-Slope	15	116-0580	1	LH Motion Control Cover ASM
1:4	116-0205	2	Decal-Belt Drive	15:2	109-7232	1	Decal-Motion Control
1:5	116-4858	1	Decal-Spark Arrester	16	116-0043-03	1	Guard-Muffler
1:6	116-1654	1	Decal-Fuel Fill	17	103-3113	1	Decal, Lazer Model
2	109-8863-03	1	Plate,Rear Guard	18	32144-10	4	Screw-HWH 1/4-20 X .62
3	116-8898-01	1	Floorpan	19	116-0170	1	LH Hydro Guard ASM
4	1-513658	2	Bumper	19:2	116-0157	1	Decal-Hydro Oil
5	116-0230	1	ASM,ROPS Service Exmark	20	116-0171	1	RH Hydro Guard ASM
6	1-811010	2	Plug	20:2	116-0157	1	Decal-Hydro Oil
7		2	Caster Wheel ASM ●	21	109-9709	1	Guard-Hydro Rear, LH Trim
9	116-0180	1	LH Bumper ASM	22	109-9058	1	Guard-Hydro, Rear RH
9:2	103-2076	1	Decal-Caution	30	103-2883	1	Decal, Exmark Logo
10	116-0057-03	1	Bumper-RH	33	1-803035	2	Rivet 3/16 X 1/4
11	104-8301	11	Nut-Nyloc 3/8-16 Flg	34	116-2362	1	Deflector-Air Flow
12	3231-22	6	Bolt-Carriage 3/8-16 X 1	66	116-3883	2	Decal-X-Series
13	3231-21	4	Bolt-Carriage 3/8-16 X 3/4	69	107-3154	2	Nut-Push 3/8-16
14	116-5899	1	RH Motion Control Cover ASM				

● Not serviced separately

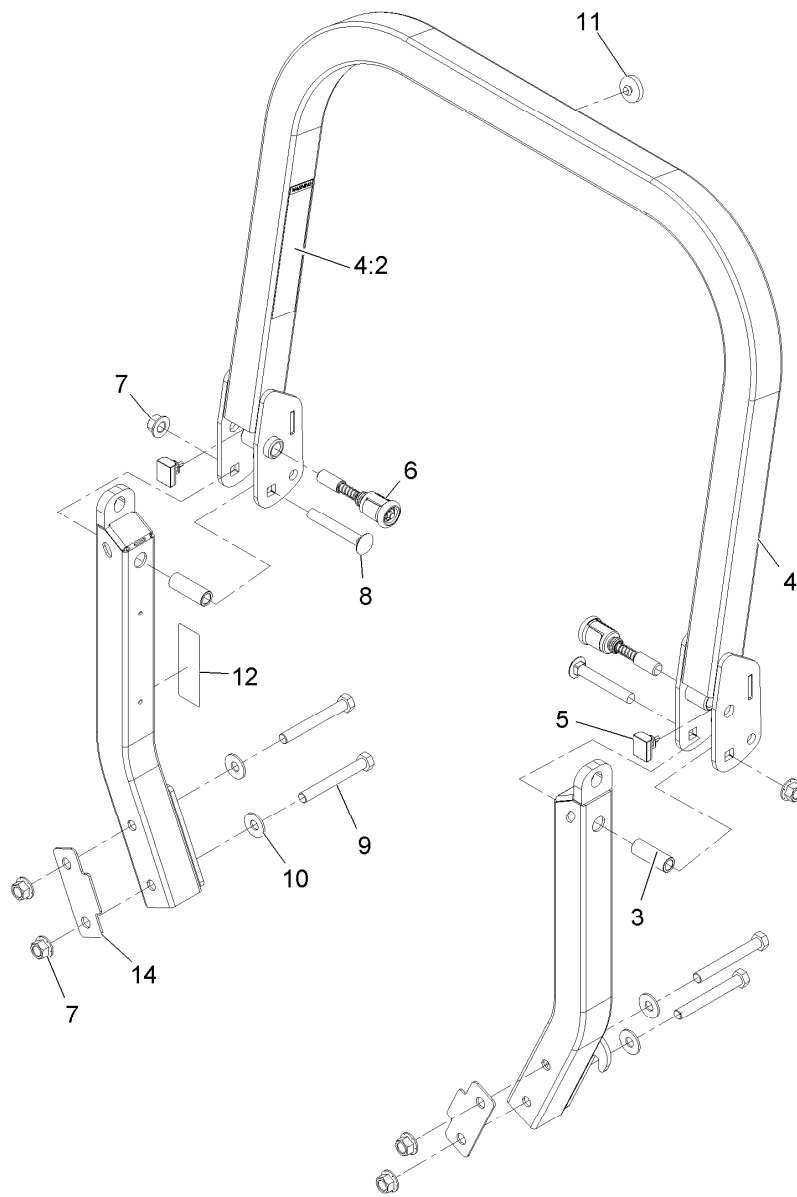

Roll-Over Protection System Assembly No. 116-0230

<i>Ref.</i>	<i>Part Number</i>	<i>Qty.</i>	<i>Description</i>
3	109-6653	2	Spacer
4	116-0019	1	Upper ROPS ASM
4:2	107-2102	1	Decal-Warning, Folding ROPS
5	109-5337	2	Bumper-ROPS
6	116-0104	2	Spring Pin ASM
7	99-5107	6	Nut-Lock 1/2-13
8	3233-10	2	Bolt-Carriage 1/2-13 X 3 1/2
9	325-17	4	Screw-HH 1/2-13 X 4
10	109-9505	4	Washer-Spring
11	109-9233	1	Bumper-Push-In, Rubber
12	116-0090	1	Decal-Caution
14	116-0960	2	Spacer

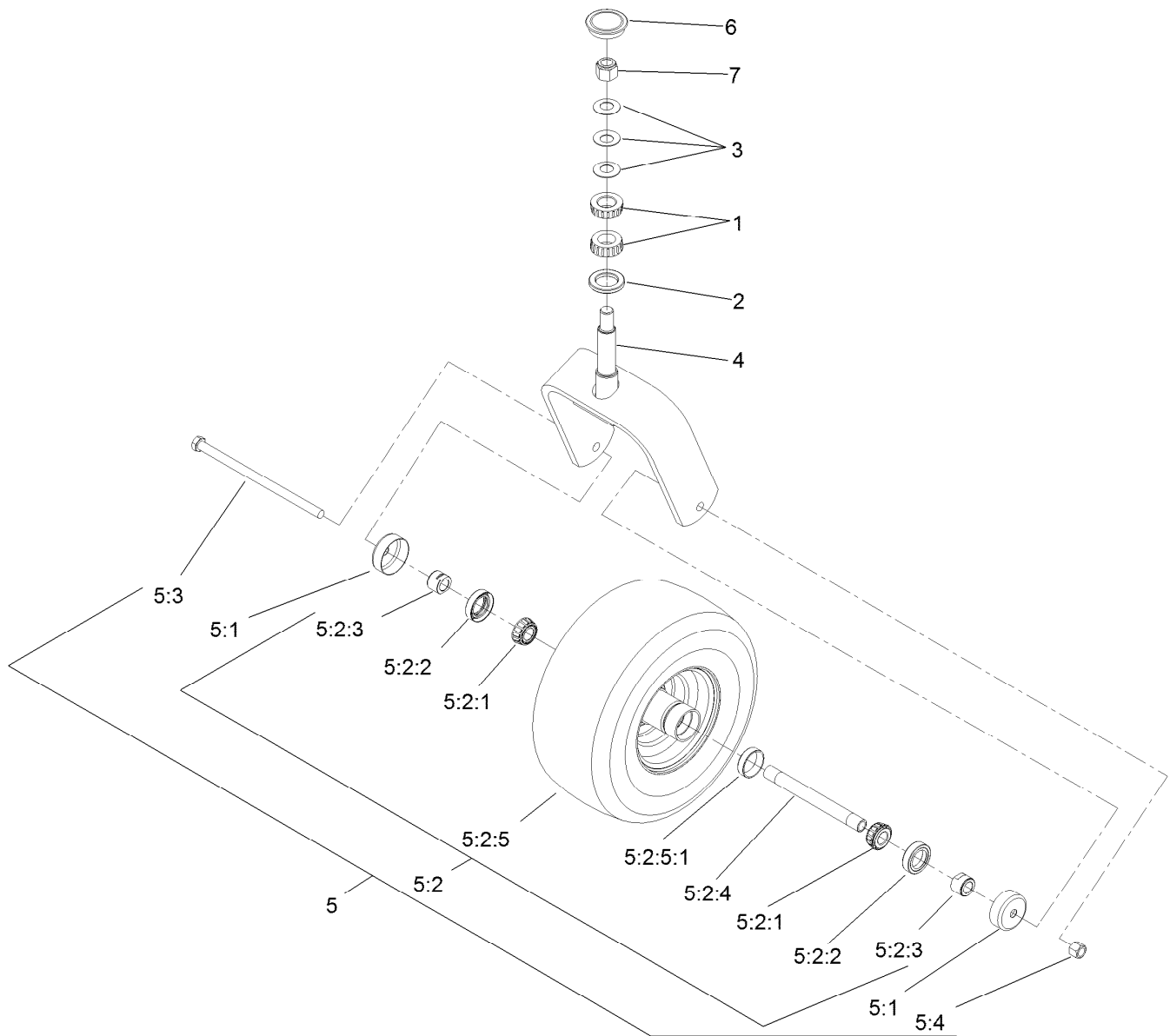

Caster Wheel and Fork Assembly

Ref.	Part Number	Qty.	Description	Ref.	Part Number	Qty.	Description
1	1-543509	2	Bearing-Roller, Tapered	5:2:3	103-3051	2	Spacer-Nut ■
2	116-5647	1	Seal-Grease	5:2:4	103-5156	1	Axle-Caster
3	1-633508	3	Washer-Bellville	5:2:5		1	Wheel And Tire ASM ●
4	116-6707-01	1	Caster	5:2:5:1	1-633584	1	Bearing-Cup
5	109-9127	1	Wheel And Tire ASM	5:3	325-39	1	Screw-HH
5:1	103-2768	2	Guard-Seal	5:4	3296-23	1	Nut-Lock, NI
5:2		1	Wheel And Tire ASM ●	6	103-4882	1	Cap-Grease
5:2:1	1-633585	2	Bearing-Cone, Taper	7	3296-51	1	Nut-Lock, NI
5:2:2	103-0063	2	Seal-Caster				

● Not serviced separately

■ Use Pro-Lock, Nut Type (P/N 1-840022, .5ml tube) on threads.

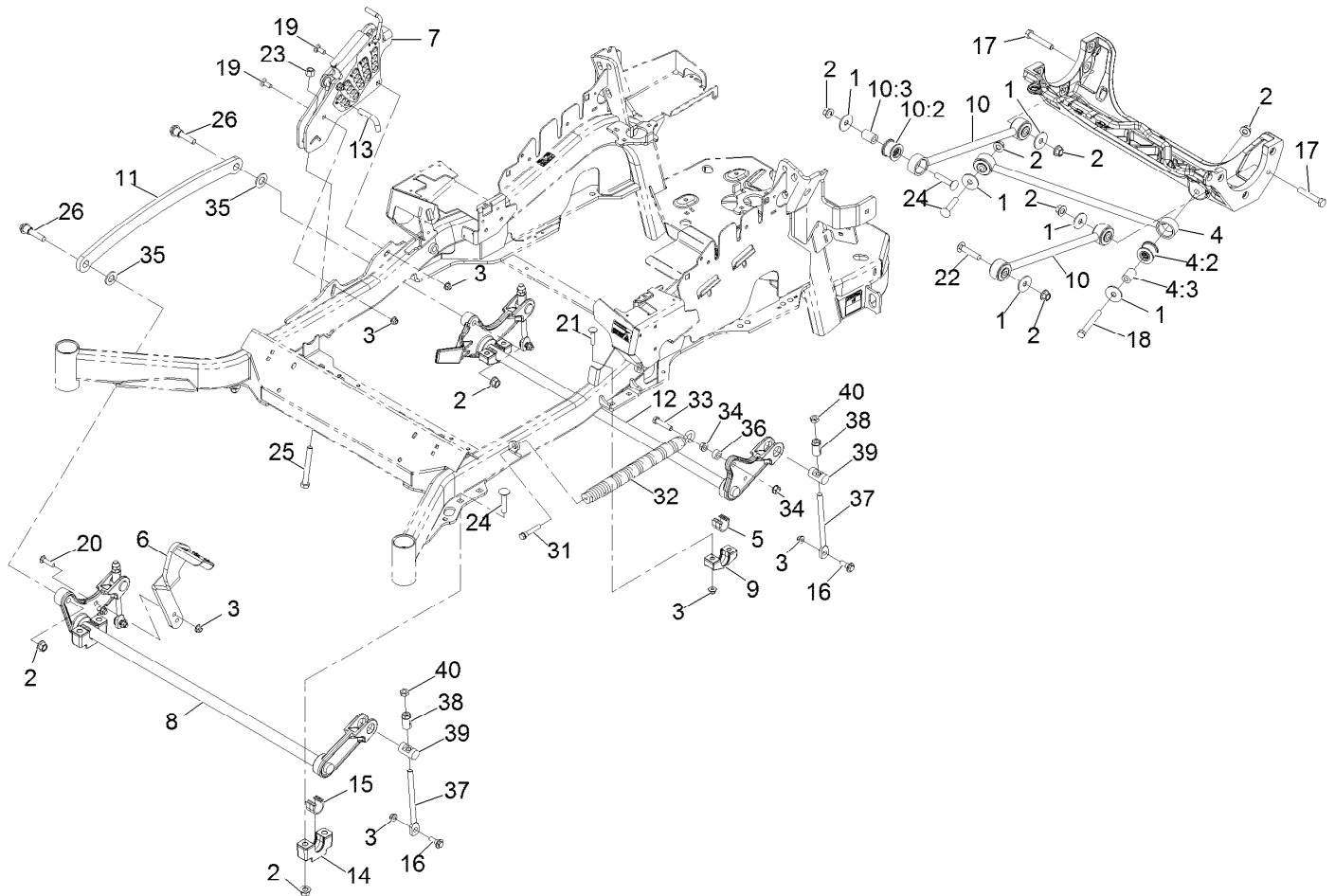

Deck Lift Assembly

Ref.	Part Number	Qty.	Description	Ref.	Part Number	Qty.	Description
1	86-1990	6	Washer	17	325-12	2	Screw-HH 1/2-13 X 3
2	99-5107	12	Nut-Lock 1/2-13	18	325-17	1	Screw-HH 1/2-13 X 4
3	104-8301	12	Nut-Nyloc 3/8-16 Flg	19	3231-2	2	Bolt-Carriage 3/8-16 X 1
4	109-5013	1	Panhard Rod ASM	20	3231-4	2	Bolt-Carriage 3/8-16 X 1 1/2
4:2	109-5009	2	Bushing-Suspension, Rubber	21	3231-5	4	Bolt-Carriage 3/8-16 X 1 3/4
4:3	109-5010	2	Spacer	22	3233-34	3	Bolt-Carriage 1/2-13 X 2 1/2
5	109-7173	2	Bearing-Cross Shaft, Rear	23	3296-23	1	Nut-Nyloc 1/2-13
6	116-1919-01	1	Lever-Foot	24	116-1700	4	Bolt-Carriage 1/2-13 X 2 1/2 Spl Neck
7	109-7438	1	HOC ASM	25	116-0559	1	Bolt-HH 1/2-13 X 4 Tap
8	116-1771-03	1	Deck Lift-Front	26	116-2022	2	Screw-Hex Flange 1/2-13 X 1.90
9	116-0818-03	2	Support-Cross Shaft, Rear Bearing	31	92-7674	1	Screw-Shcs 3/8-16 X 2.212
10	109-7952	2	Deck Strut ASM	32	116-0000	1	Extension Spring ASM
10:2	109-5009	2	Bushing-Suspension, Rubber	33	109-9065	1	Screw-HH 7/16-14 X 2
10:3	109-5010	2	Spacer	34	32128-37	2	Nut-Whizlock 7/16-14
11	116-0797-03	1	Link-Lift, Deck	35	3256-28	2	Washer-3/4 Sae
12	116-2645-03	1	Lift-Deck, Rear	36	116-2695	1	Spacer
13	116-5584	1	Pin-HOC	37	109-8007	4	Link-Adjuster, Deck Lift
14	109-9409	2	Support-Cross Shaft, Front Bearing	38	109-7840	4	Adjuster-Lift, Deck
15	109-9410	2	Bearing-Cross Shaft, Front	39	109-8353	4	Trunnion
16	109-9840	4	Screw-Hex Flange 3/8-16 X .80	40	3218-5	4	Nut-Jam 1/2-13

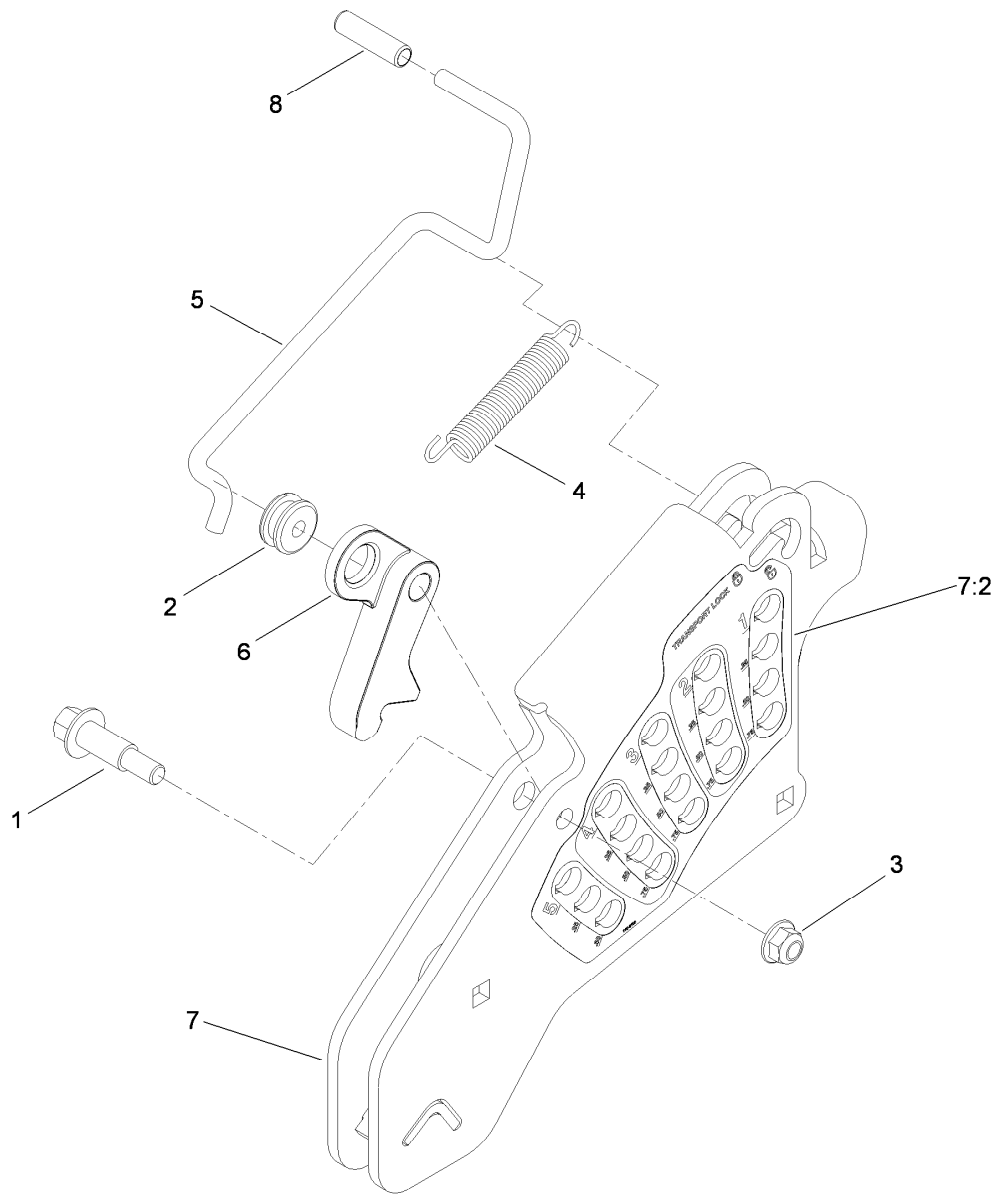

Height-of-Cut Assembly No. 109-7438

<i>Ref.</i>	<i>Part Number</i>	<i>Qty.</i>	<i>Description</i>
1	62-1330	1	Bolt-Shoulder
2	109-7130	1	Grommet
3	104-8301	1	Nut-Flange, NI
4	109-7124	1	Spring-Extension
5	109-7128	1	Rod-Lock, Transport
6	116-0118	1	Pawl-Transport, HOC
7	109-7335	1	HOC Plate ASM
7:2	116-0752	1	Decal-HOC
8	109-8250	1	Grip-Lever

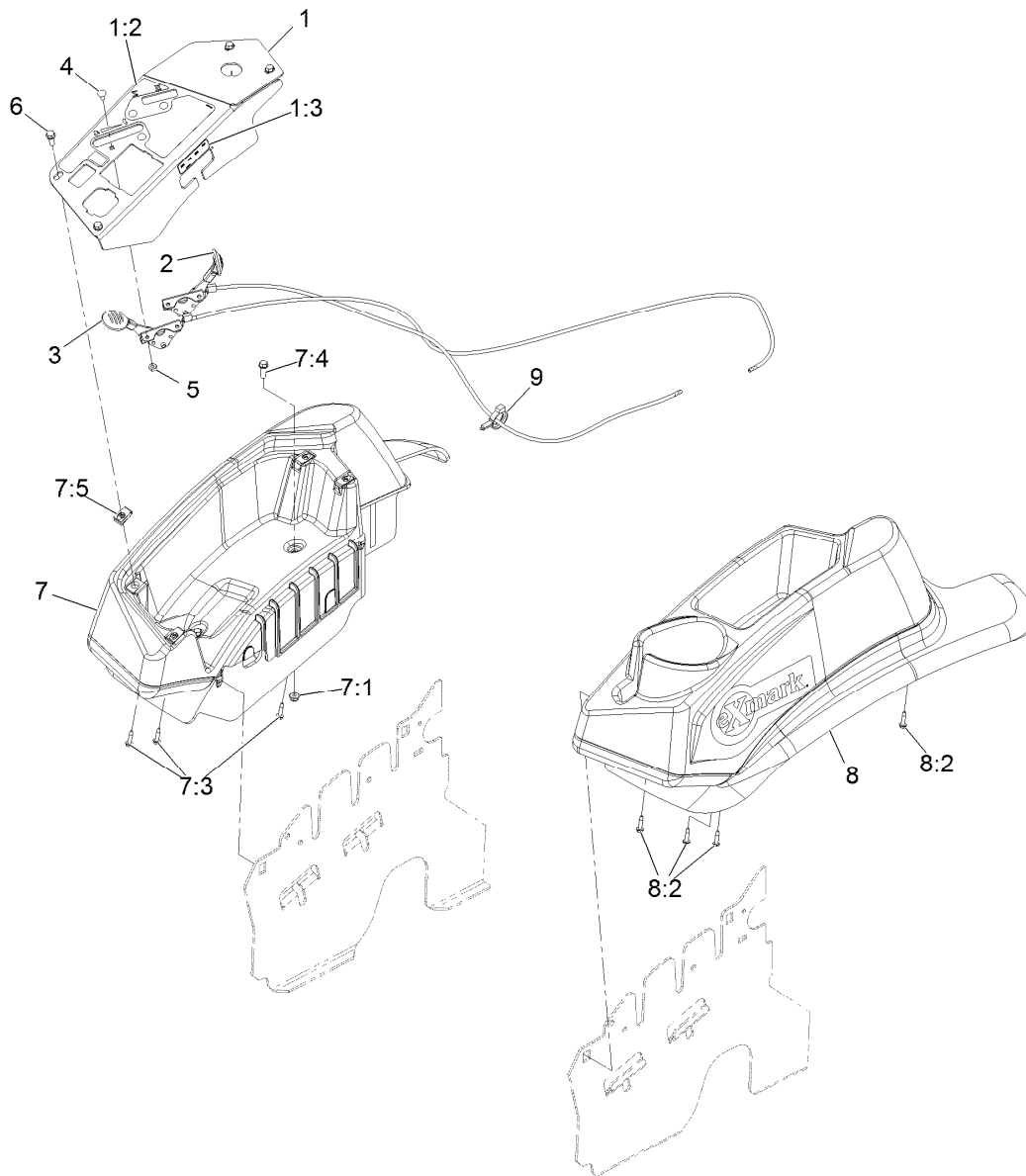

Control Assembly

<i>Ref.</i>	<i>Part Number</i>	<i>Qty.</i>	<i>Description</i>
1	109-8484	1	Console,Panel W/Decal
1:2	109-8483	1	Decal-Control Panel
1:3	109-7330	1	Decal-Fuse
2	109-8165	1	ASM, Choke Cable
3	116-0969	1	ASM,Throttle Cable
4	1-807513	4	Bolt-Carriage #10-24 X 1/2
5	3296-2	4	Nut-Nyloc #10-24
6	32105-15	4	Screw-Machine 1/4-20 X 3/4

<i>Ref.</i>	<i>Part Number</i>	<i>Qty.</i>	<i>Description</i>
7	109-9341	1	Console,RH Narrow ASM
7:1	104-7201	2	Nut-Nyloc 1/4-20 Flg
7:3	109-9345	3	Screw-HWH #10-14 X 3/4 Tf
7:4	32105-15	2	Screw-Machine 1/4-20 X 3/4
7:5	107069	4	Nut-Retainer-Panel 1/4-20
8	109-9342	1	Console.LH Narrow ASM
8:2	109-9345	4	Screw-HWH #10-14 X 3/4 Tf
9	105-1853	1	Clamp-Hose

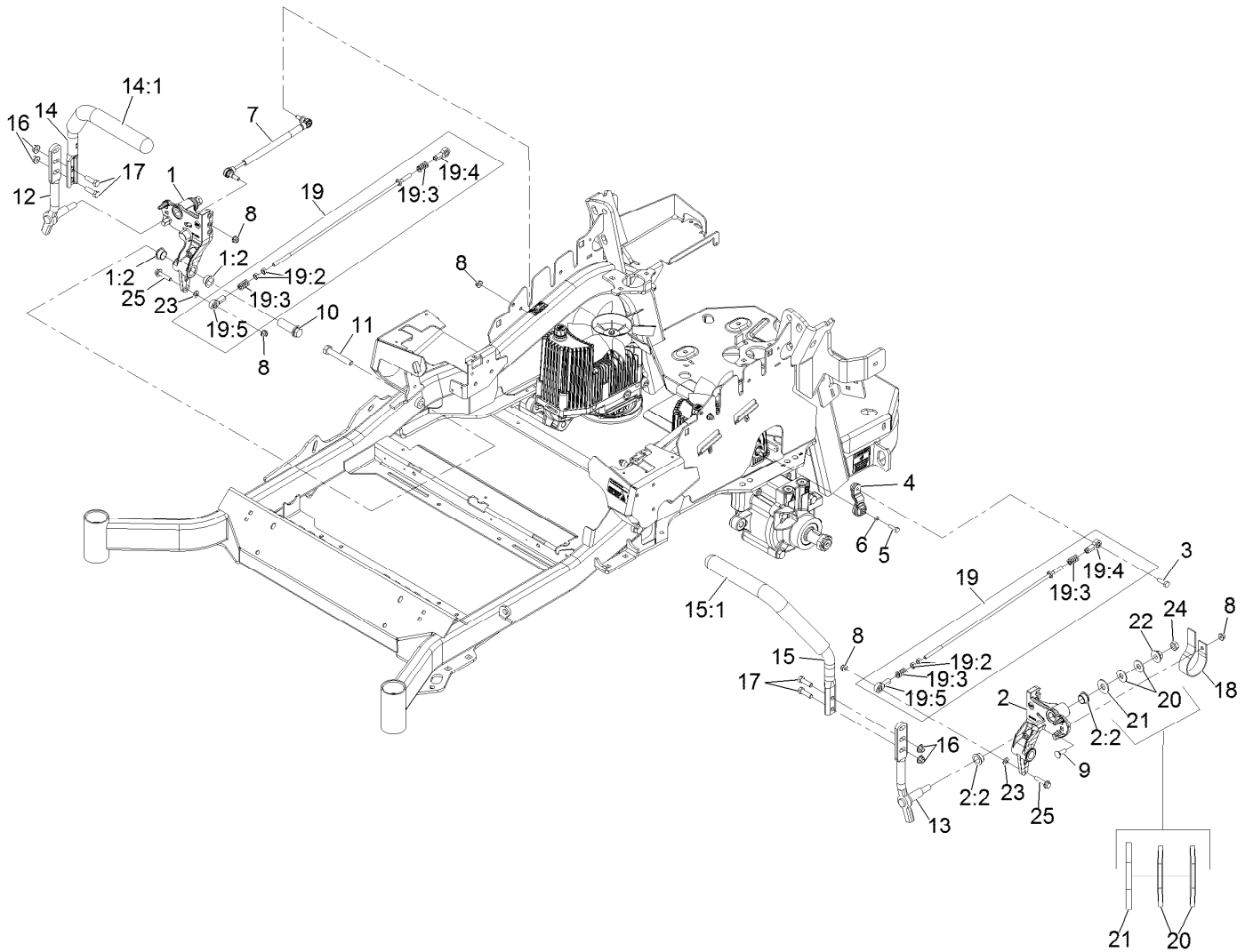

Motion Control Assembly

Ref.	Part Number	Qty.	Description	Ref.	Part Number	Qty.	Description
1	116-0880	1	RH Motion Control And Bushing ASM	14:1	109-5668	1	Grip-Control, Lever
1:2	109-8054	4	Bushing-Flanged	15	109-6590	1	LH Steering Handle ASM
2	116-0881	1	LH Motion Control And Bushing ASM	15:1	109-5668	1	Grip-Control, Lever
2:2	109-8054	4	Bushing-Flanged	16	104-8301	4	Nut-Nyloc 3/8-16 Flg
3	116-0648	2	Screw-HH 5/16-18 X 1 W/Patch ●	17	323-7	4	Screw-HH 3/8-16 X 1 1/4
4	109-4581	2	Arm-Control, Pump	18	109-5575	2	Spring-Leaf
5	9080046	2	Screw-HH 1/4-20 X 7/8 ●	19	109-8106	2	Front Pump Linkage ASM
6	1-303435	2	Washer-Spring Disc 1/4	19:2	3219-2	2	Nut-Hex 5/16-24
7	116-0027	2	Damper-Control, Motion	19:3	1-323245	2	Spring-Compression
8	104-8300	8	Nut-Nyloc 5/16-18 Flg	19:4	1-633152	1	Balljoint
9	3230-2	2	Bolt-Carriage 5/16-18 X 1	19:5	1-543017	1	Balljoint
10	109-5891	2	Hub-Threaded	20	109-9505	4	Washer, Spring Disc 1/2
11	325-12	2	Screw-HH 1/2-13 X 3	21	3256-6	2	Washer
12	116-0039	1	Lever-Control Motion, RH	22	32128-56	2	Nut-Hex 1/2-13 Flange
13	116-0040	1	Lever-Control Motion, LH	23	3256-23	2	Washer-5/16 Sae
14	109-6589	1	RH Steering Handle ASM	24	3218-5	2	Nut-Jam 1/2-13
				25	115-1794	2	Screw-Hex Flange 5/16-18 X 1 1/2

● Use Pro-Lock, Nut Type (P/N 1-840022, .5ml tube) on threads.

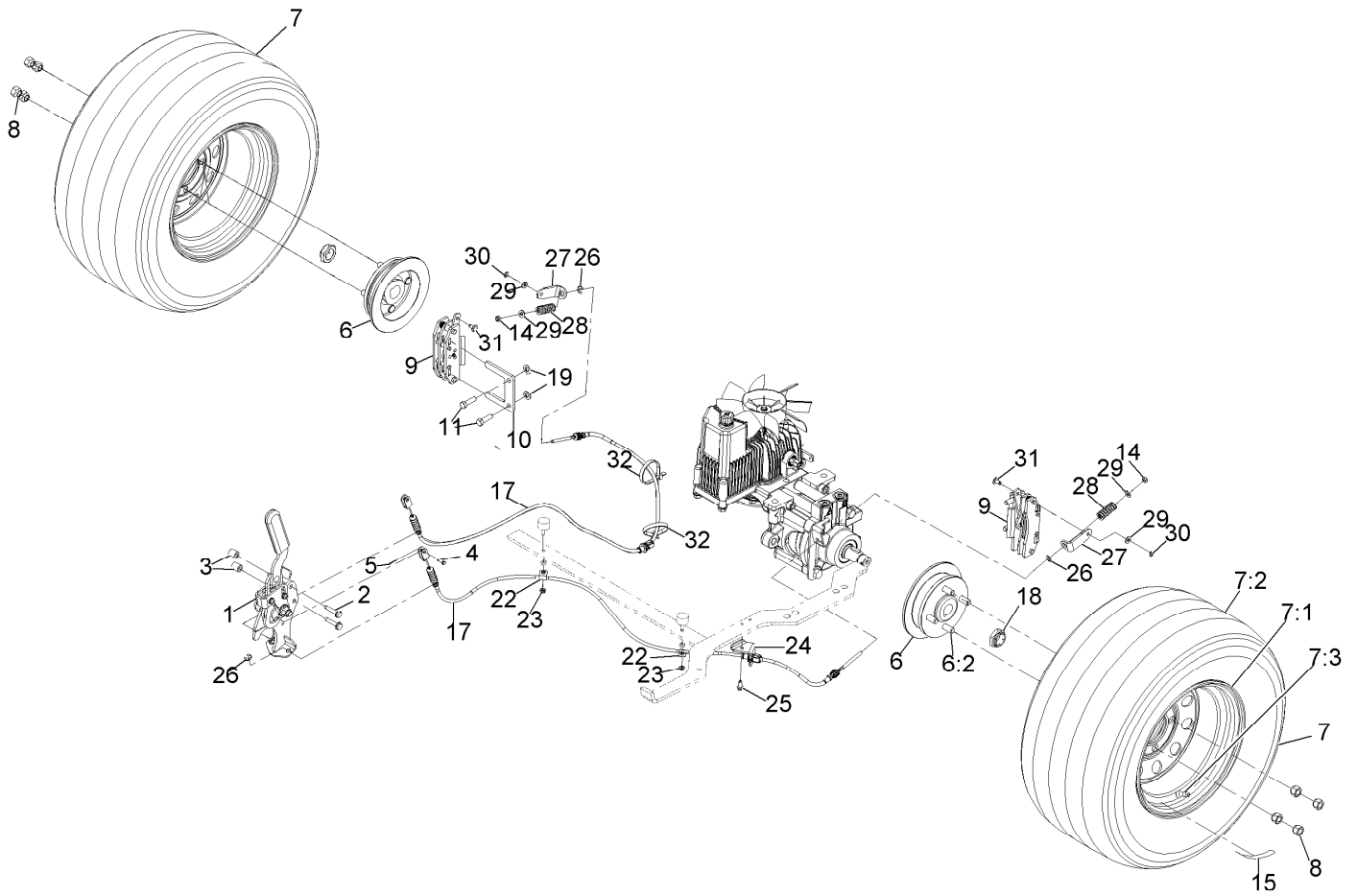

Rear Wheel and Park Brake Assembly

Ref.	Part Number	Qty.	Description	Ref.	Part Number	Qty.	Description
1	116-7551	1	Brake Handle ASM	14	3296-13	2	Nut-Nyloc 1/4-28
2	32144-57	2	Screw	15	116-2643	2	Decal-Wheel Nut Torque
3	82-6840	2	Spacer	17	116-6365	2	Cable-Park Brake, LH
4	60-1730	2	Pin-Clevis	18	116-1399	2	Locknut
5	3272-1	2	Pin-Cotter 1/16 X 1/2	19	3256-24	4	Washer-3/8 Sae
6	116-1746	2	Wheel Hub ASM	22	88-7970	2	Clip
6:2	116-1696	4	Stud-Wheel	23	3296-56	2	Nut-Nyloc 1/4-20 Thin
7	109-8972	2	Wheel And Tire ASM	24	116-6397	1	Bracket-Cable
7:1	1-633993	1	Tire	25	32144-10	1	Screw-HWH 1/4-20 X .62
7:2	109-3156	1	Rim ASM	26	32120-18	4	E-Ring
7:3	232-27	1	Stem-Valve	27	116-6182	2	Bracket-Brake, L
8	242-50	8	Nut-Lug 1/2-20	28	116-6347	2	Spring-Die
9	109-2889	2	Caliper-Brake	29	3256-22	4	Washer-1/4 Sae
10	109-0958	2	Plate-Mount, Brake	30	32151-86	2	E-Ring
11	92-5727	4	Screw-HH 3/8-16 X 1 1/4 Patch Lock	31	116-6348	2	Pin-Brake
				32	3334-945	2	Tie-Cable

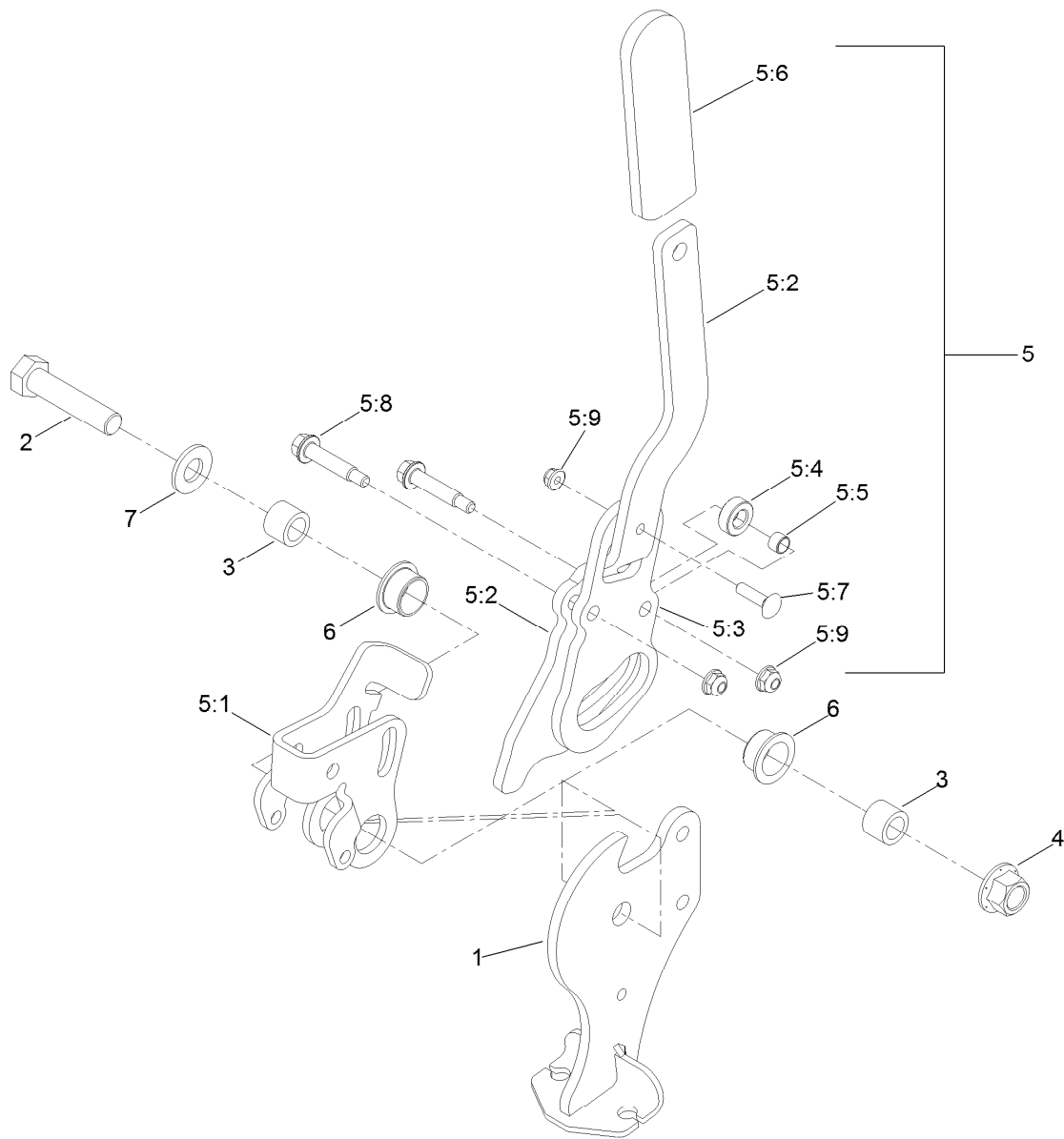

Parking Brake Handle Assembly No. 116-7551

<i>Ref.</i>	<i>Part Number</i>	<i>Qty.</i>	<i>Description</i>
1	116-7263	1	Brake Pivot ASM
2	325-9	1	Screw-HH
3	116-5384	2	Spacer
4	99-5107	1	Nut-Lock
5	116-6860	1	Handle ASM
5:1	116-6856	1	Bellcrank-Brake
5:2	116-6857	1	Handle-Brake
5:3	116-6858	1	Plate-Handle

<i>Ref.</i>	<i>Part Number</i>	<i>Qty.</i>	<i>Description</i>
5:4	116-6846	1	Roller-Brake
5:5	116-6852	1	Bearing-Sleeve
5:6	1-633268	1	Grip-Lever
5:7	3229-2	1	Screw-CARR
5:8	116-6876	2	Screw-Shoulder
5:9	104-7201	3	Nut-HF
6	109-8054	2	Bushing-Flange
7	3256-26	1	Washer-Flat

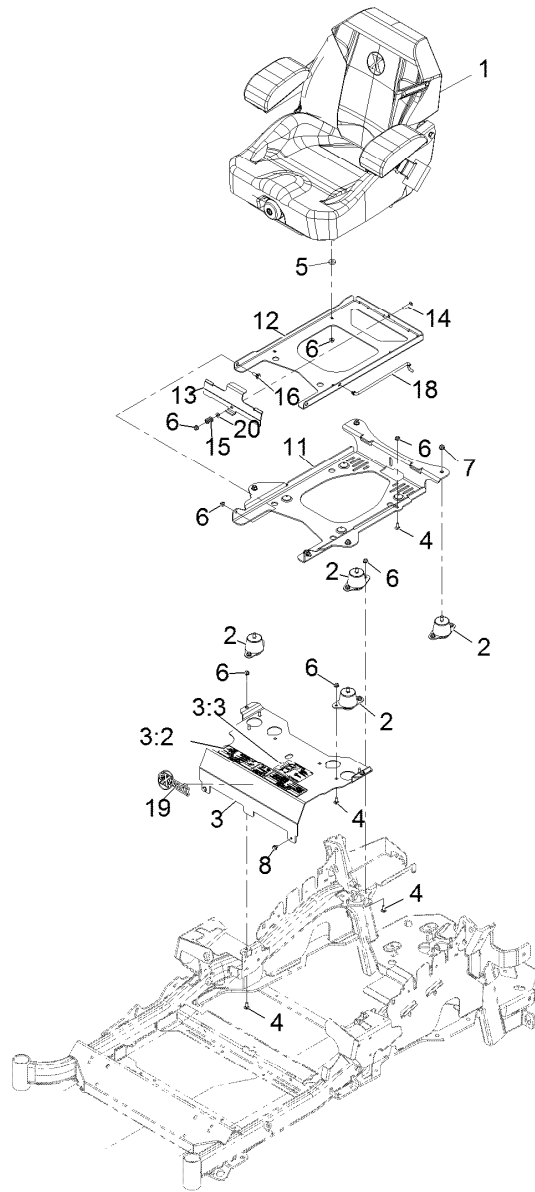

Seat Assembly

<i>Ref.</i>	<i>Part Number</i>	<i>Qty.</i>	<i>Description</i>	<i>Ref.</i>	<i>Part Number</i>	<i>Qty.</i>	<i>Description</i>
1	116-8912	1	Kit-Suspension Seat	11	116-3860-03	1	Plate-Tilt, Seat Support
2	109-9034	4	Isolator-Seat	12	116-3859-03	1	Plate-Seat, Frame
3	116-2323	1	Mount-Seat	13	109-9881-03	1	Plate-Latch, Seat
3:2	109-7069	1	Decal-Console	14	3230-4	1	Bolt-Carriage 5/16-18 X 1 1/2
3:3	116-0211	1	Decal-Service Aid	15	107-3017	1	Spring-Compression
4	3230-23	11	Bolt-Carriage 5/16-18 X 3/4 Short Neck	16	116-1297	2	Screw-Shoulder
5	26-4840	4	Spacer-Pin, Mounting	18	116-0070	1	Rod-Prop
6	104-8300	18	Nut-Nyloc 5/16-18 Flg	19	103-2883	1	Decal, Exmark Logo
7	104-8301	4	Nut-Nyloc 3/8-16 Flg	20	3256-23	1	Washer-5/16 Sae
8	9266934	2	Screw-HWH 5/16 X 1/2 Tf				

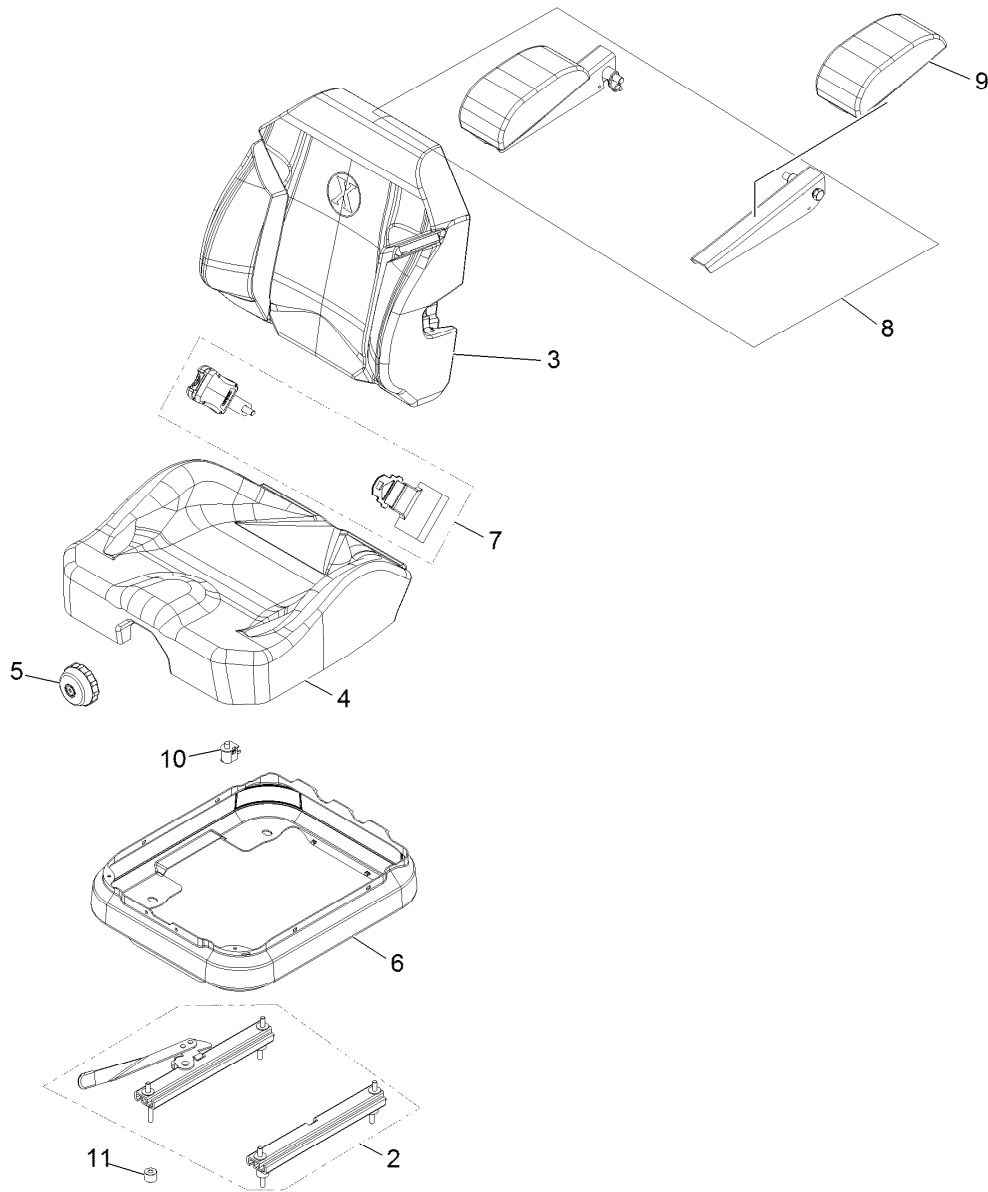

Seat W/Tracks Assembly No. 116-8912

<i>Ref.</i>	<i>Part Number</i>	<i>Qty.</i>	<i>Description</i>
2	116-8910	1	Seat Track Set
3	116-8908	1	Cover-Back 311463Vn500
4	116-8909	1	Cover-Cushion 311464Vn500
5	116-8911	1	Knob-Adjuster
6	116-5659	1	Cover-Suspension Bellows
7	109-9805	1	Seat Belt Kit
8	116-8906	1	Kit-Arm Rest Set
9	116-8905	1	Kit-Arm Rest Pads
10	82-2190	1	Switch
11	116-9329	4	Spacer

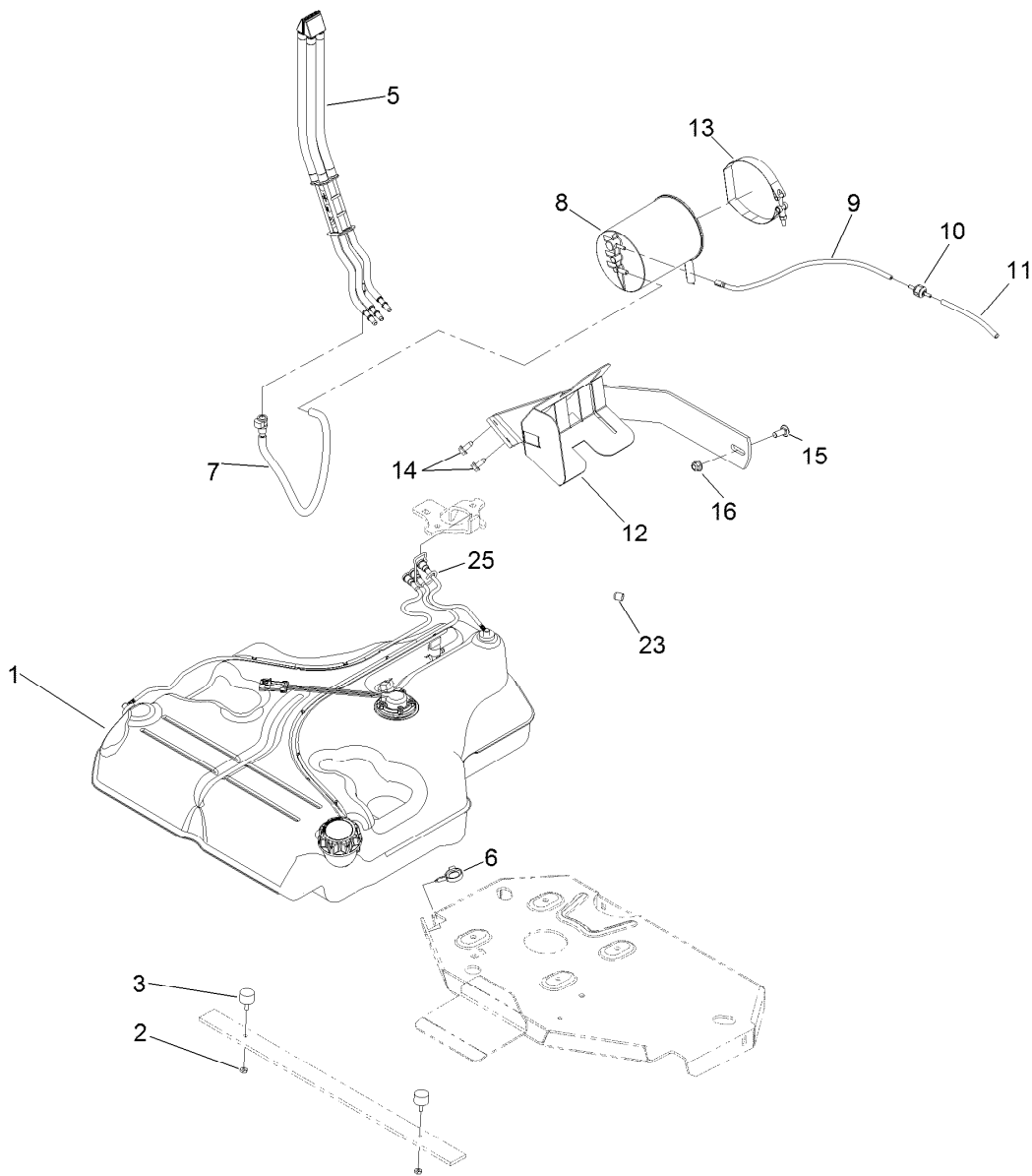

Fuel Tank Mounting Assembly

<i>Ref.</i>	<i>Part Number</i>	<i>Qty.</i>	<i>Description</i>	<i>Ref.</i>	<i>Part Number</i>	<i>Qty.</i>	<i>Description</i>
1	116-3979	1	Fuel Tank ASM	11	119-4235	1	Hose-Vent, Formed
2	3218-1	2	Nut-Jam	12	116-1433-03	1	Mount-Canister
3	116-6380	2	Bumper-Rubber (W/ Stud)	13	116-2228	1	Clamp-T-Bolt
5	109-9491	1	Fuel Manifold Vent ASM	14	32144-70	2	Screw-HWHTF
6	105-1853	1	Clamp-Hose	15	3231-22	1	Screw-CARR
7	116-1702	1	Vent Hose ASM	16	104-8301	1	Nut-Flange, NI
8	116-1442	1	Canister-Carbon, 1200Cc	23	116-4464	1	Plug-Port
9	116-2963	1	Hose-Vent, Formed	25	116-6005	1	Retainer-Vapor Line
10	115-7868	1	Valve-Check, Vacuum				

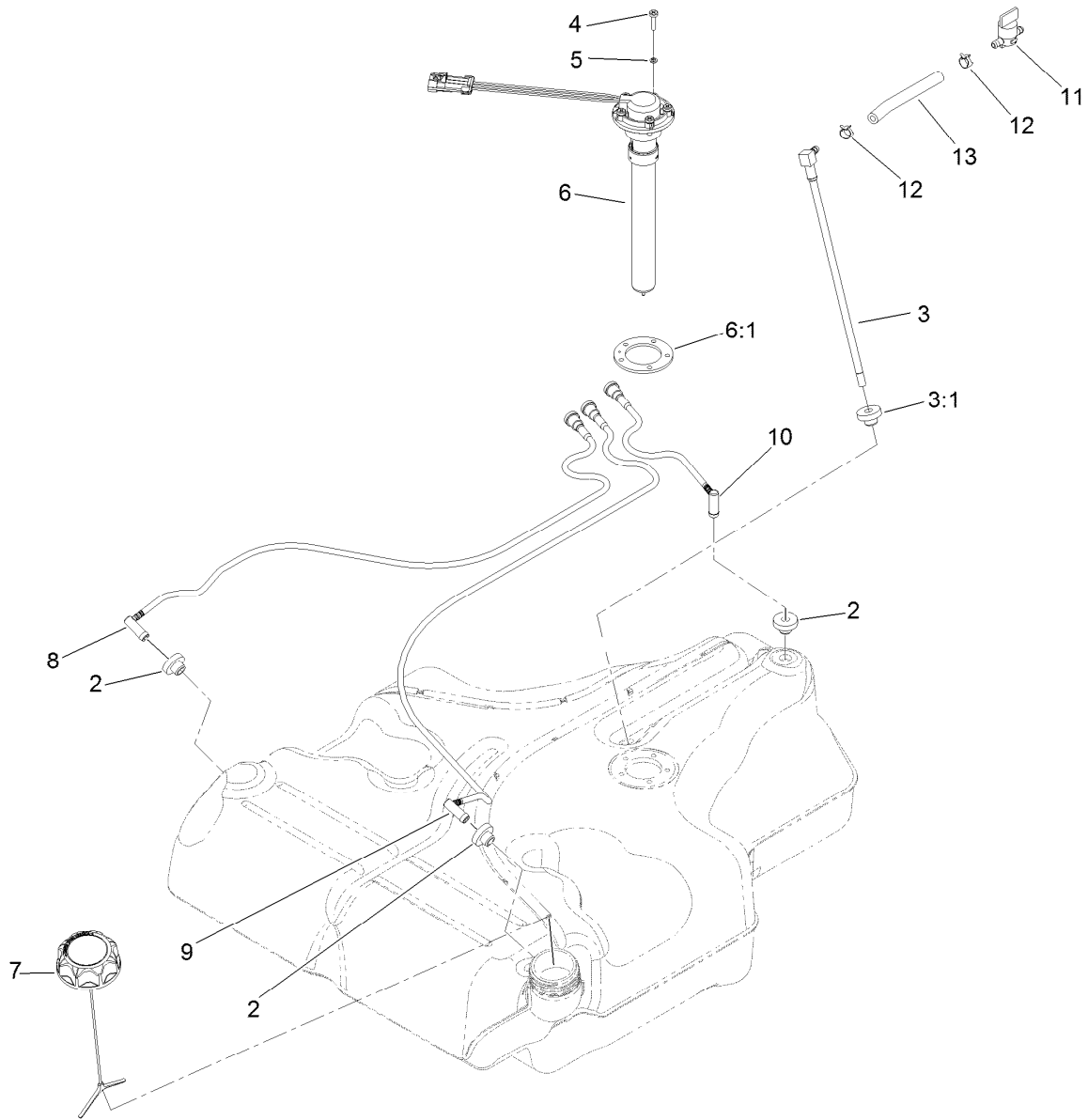

Fuel Tank Assembly No. 116-3979

Ref.	Part Number	Qty.	Description
2	46-6560	4	Bushing
3	116-2459	1	Fuel Line Kit (With Grommet)
3:1	46-6560	1	Bushing
4	9107944	5	Screw-Pan
5	3253-17	5	Washer-Lock
6	116-0003	1	Sender-Fuel Level
6:1	109-9620	1	Gasket-Sender, Fuel
7	116-1704	1	Cap-Fuel, Ratcheting
8	116-2460	1	RH Vent Line Kit (With Grommet)
9	116-2461	1	LH Vent Line Kit (With Grommet)
10	116-2462	1	Rear Vent Line Kit (With Grommet)
11	1-603770	1	Valve-Fuel
12	2412-98	2	Clamp-Hose
13	109-0650	1	Hose-Fuel

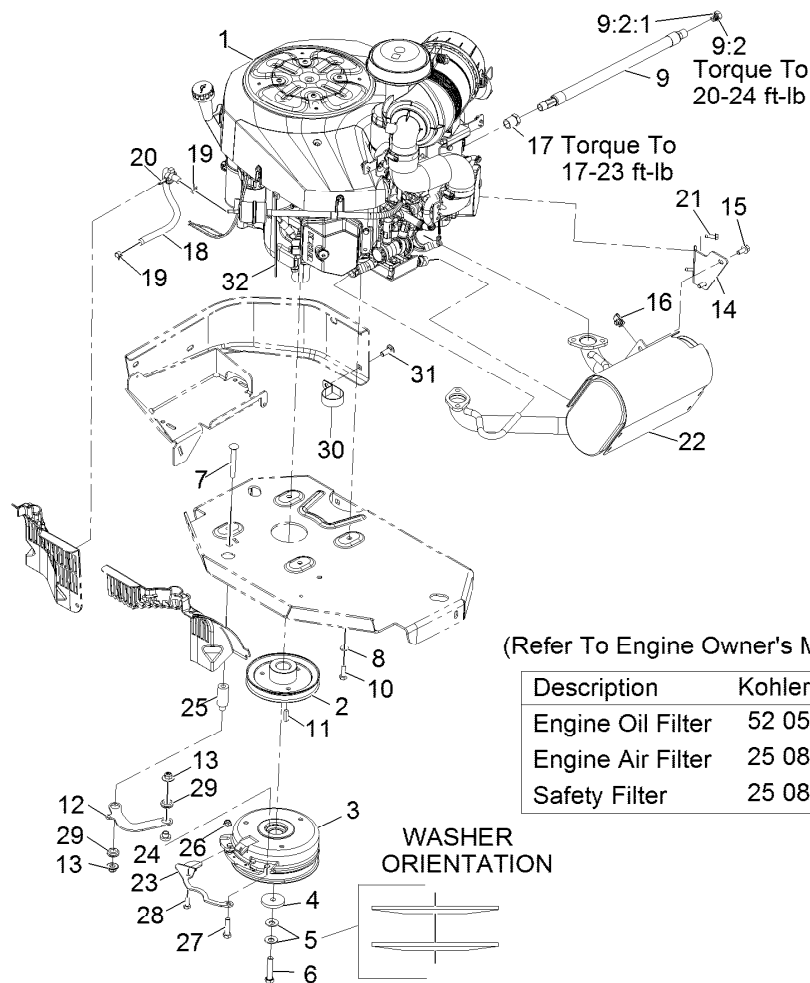

Engine Assembly

Ref.	Part Number	Qty.	Description	Ref.	Part Number	Qty.	Description
1		1	Engine-Kohler ●■	16	94-2413	2	U-Nut
2	109-9905	1	Sheave	17	103-1390	1	Bushing
3	116-1621	1	Clutch Kit	18	109-0305	1	Hose-Fuel Line 13 3/4"
4	109-6919	1	Washer-Clutch	19	2412-98	2	Clamp-Hose
5	1-603610	2	Washer-Spring Disc 7/16	20	105-1853	1	Clamp-Hose
6	109-9762	1	Screw-HH 7/16-20 X 2 W/Loctite ▲	21	110-3986	2	Screw-HH M6-1 X 20Mm
7	3231-42	1	Bolt-Carriage 3/8-16 X 3	22	116-6137	1	Muffler
8	1-303334	4	Washer-Spring Disc 5/16	23	116-3331-01	1	Belt-Guide
9	116-5316	1	Oil Drain Hose ASM	24	116-3318	1	Spacer
9:2	353-508	1	Plug-W/O-Ring	25	116-3319	1	Spacer
9:2:1	237-42	1	O-Ring	26	104-8300	1	Nut-Nyloc 5/16-18 Flg
10	33114-025	4	Screw-HH M8-1.25 X 25Mm	27	323-8	1	Screw-HH 3/8-16 X 1 1/2
11	1-807259	1	Key-Machine 1/4 X 1/4 X 1	28	322-4	1	Screw-HH 5/16-18 X 7/8
12	116-3317-01	1	Link-Anchor, Clutch	29	93-5108	2	Grommet-Rubber
13	109-6658	2	Nut-Nyloc 3/8-16 Flg	30	2412-147	1	Clamp
14	116-9048	1	Bracket-Muffler	31	3231-22	1	Bolt-Carriage 3/8-16 X 1
15	3234-5	2	Screw-HH Flg 5/16-18 X 3/4	32	1-303335	1	Tie-Cable 7 15/16 (Large)

● Not serviced separately

▲ Use Pro-Lock, Nut Type (P/N 1-840022, .5ml tube) on threads.

■ Obtain parts from www.kohlerplus.com

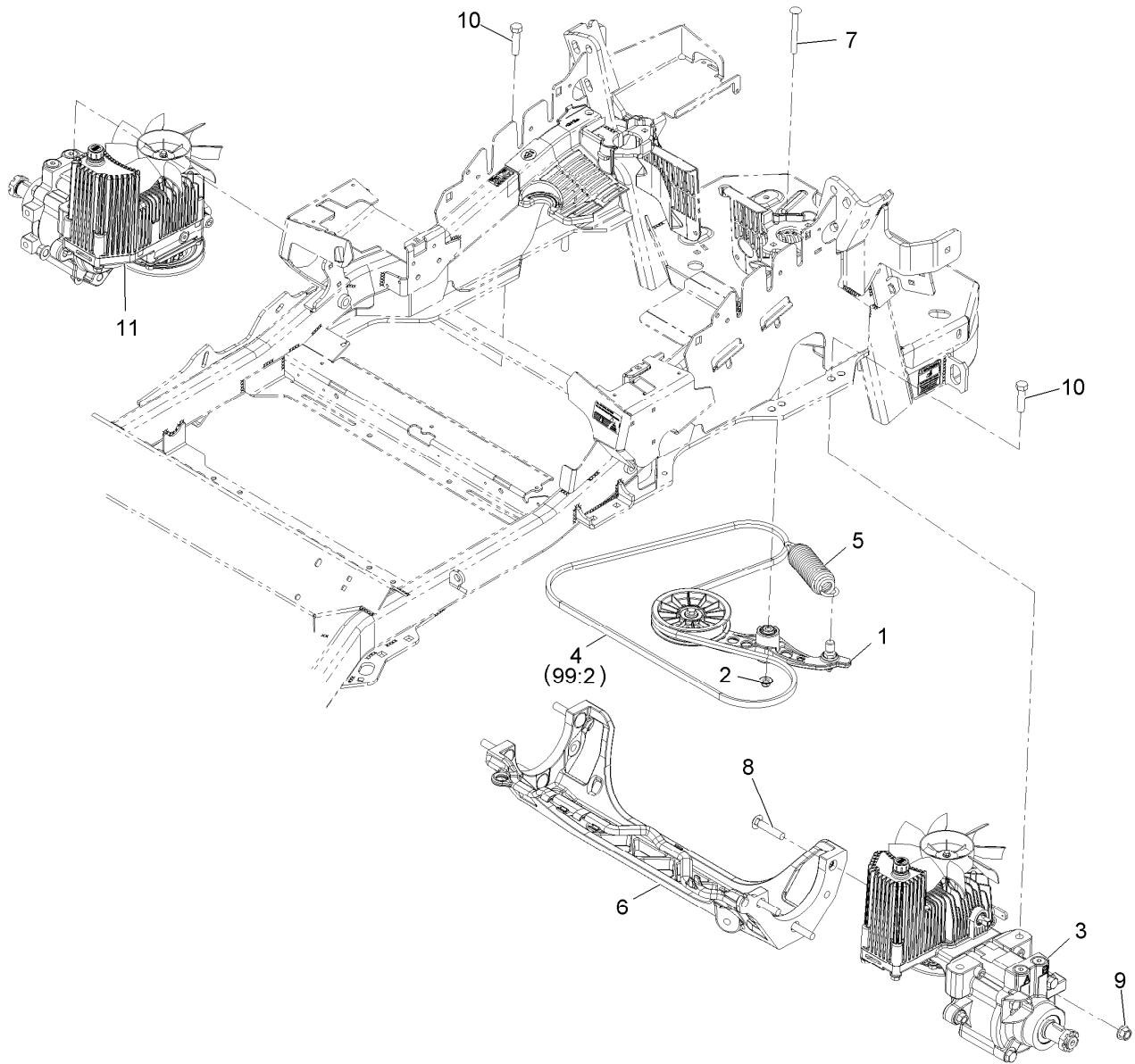

Hydraulic Assembly

Ref.	Part Number	Qty.	Description	Ref.	Part Number	Qty.	Description
1	116-1255	1	Pump Idler ASM	10	325-8	4	Screw-HH 1/2-13 X 1 1/4
2	109-6658	1	Nut-Nyloc 3/8-16 Flg	11	116-6410	1	RH Hydro ASM (16Cc W/Shock)
3	116-6409	1	LH Hydro ASM (16Cc W/Shock)	99	109-9828	1	Bottle-Oil, 32Oz Hydraulic ●
4	109-3388	1	Belt	99	116-0164	1	Filter-Hydro ●
5	116-6317	1	Spring-Extension	99	116-1218	1	Bottle, Oil 1 Gallon Hydraulic ●
6	109-9375	1	Cradle-Hydro	99	116-3270	1	Kit, Hydro Service ●
7	116-1502	1	Bolt-Carriage Shoulder 3/8-16 X 3 1/2	99:1	109-9828	4	Bottle-Oil, 32Oz Hydraulic ●
8	3233-34	6	Bolt-Carriage 1/2-13 X 2 1/2	99:2	109-3388	1	Belt
9	99-5107	6	Nut-Lock 1/2-13	99:3	116-0164	2	Filter-Hydro ●

● Not illustrated

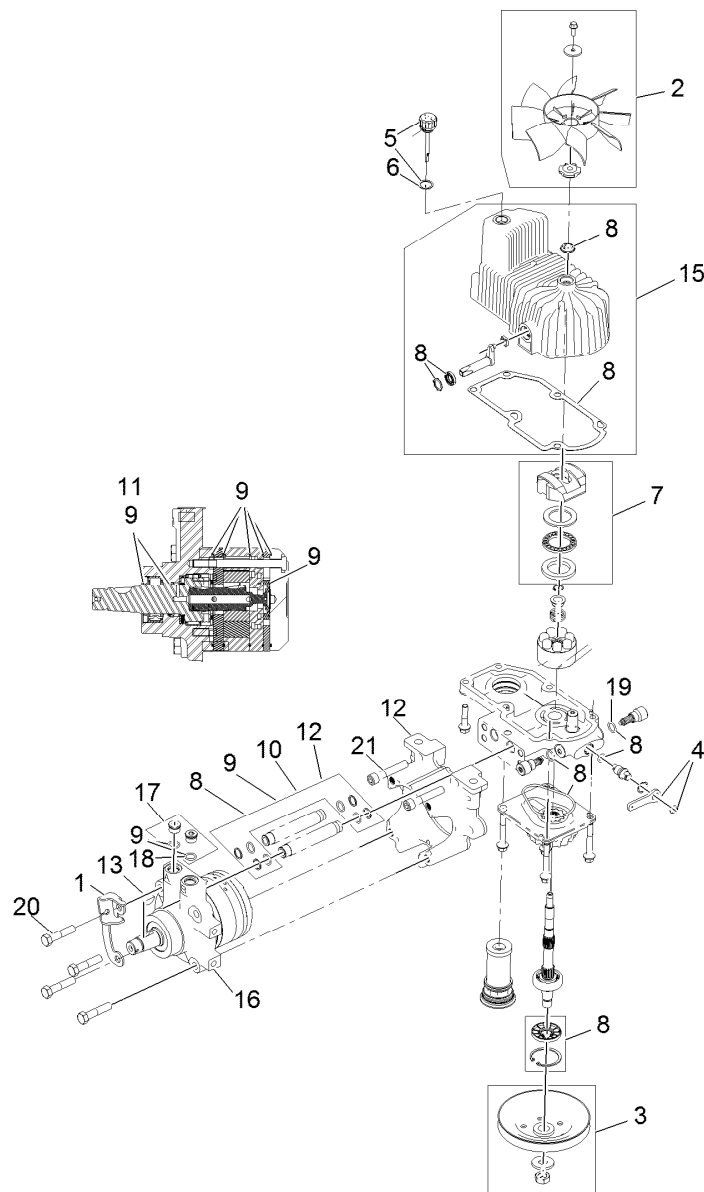

LH Hydro Assembly No. 116-6409

Ref.	Part Number	Qty.	Description	Ref.	Part Number	Qty.	Description
1	116-6859	1	Bracket-Anchor, Cable	11	116-1371	1	Output Shaft Seal Kit
2	116-0233	1	Fan Kit	12	116-5469	1	Nose Cup-Uht
3	116-0234	1	Pulley Kit	13	3257-42	1	Key-Woodruff 5/16 X 1
4	116-0235	1	Handle-Bypass Valve, Hydro	15	115-3287	1	Housing-Hydro LH
5	116-0236	1	Dipstick-Hydro W/Gasket	16	116-8917	1	Motor-Hydraulic, LH 280Cc
6	116-0237	1	Gasket-Dipstick, Hydro	17	116-7901	1	Magnetic Plugs Service Kit
7	116-1367	1	Swash Block Kit	18	76-1900	2	O-Ring
8	116-1368	1	Pump Seal Kit	19	116-8662	2	O-Ring-Check Valve
9	116-1369	1	Motor Seal Kit	20	116-8974	4	Screw-HH 1/2-20 X 2 1/4
10	116-1370	1	Tube Seal Kit	21	116-8975	2	Screw-HSH 1/2-20 X 2 3/4
				99	116-1373	1	Flow Test Kit ●

● Not illustrated

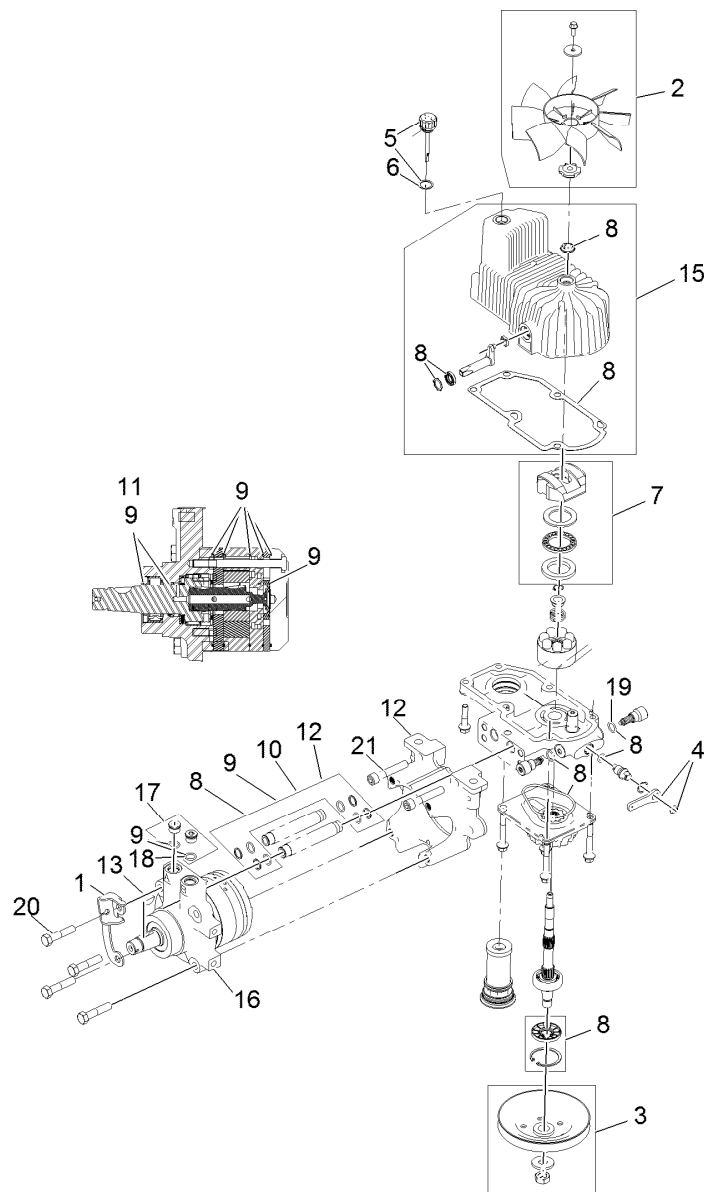

RH Hydro Assembly No. 116-6410

Ref.	Part Number	Qty.	Description	Ref.	Part Number	Qty.	Description
1	116-6859	1	Bracket-Anchor, Cable	11	116-1371	1	Output Shaft Seal Kit
2	116-0233	1	Fan Kit	12	116-5469	1	Nose Cup-Uht
3	116-0234	1	Pulley Kit	13	3257-42	1	Key-Woodruff 5/16 X 1
4	116-0235	1	Handle-Bypass Valve, Hydro	15	116-3288	1	Housing-RH
5	116-0236	1	Dipstick-Hydro W/Gasket	16	116-8918	1	Motor-Hydraulic, RH 280Cc
6	116-0237	1	Gasket-Dipstick, Hydro	17	116-7901	1	Magnetic Plugs Service Kit
7	116-1367	1	Swash Block Kit	18	76-1900	2	O-Ring
8	116-1368	1	Pump Seal Kit	19	116-8662	2	O-Ring-Check Valve
9	116-1369	1	Motor Seal Kit	20	116-8974	4	Screw-HH 1/2-20 X 2 1/4
10	116-1370	1	Tube Seal Kit	21	116-8975	2	Screw-HSH 1/2-20 X 2 3/4
				99	116-1373	1	Flow Test Kit ●

● Not illustrated

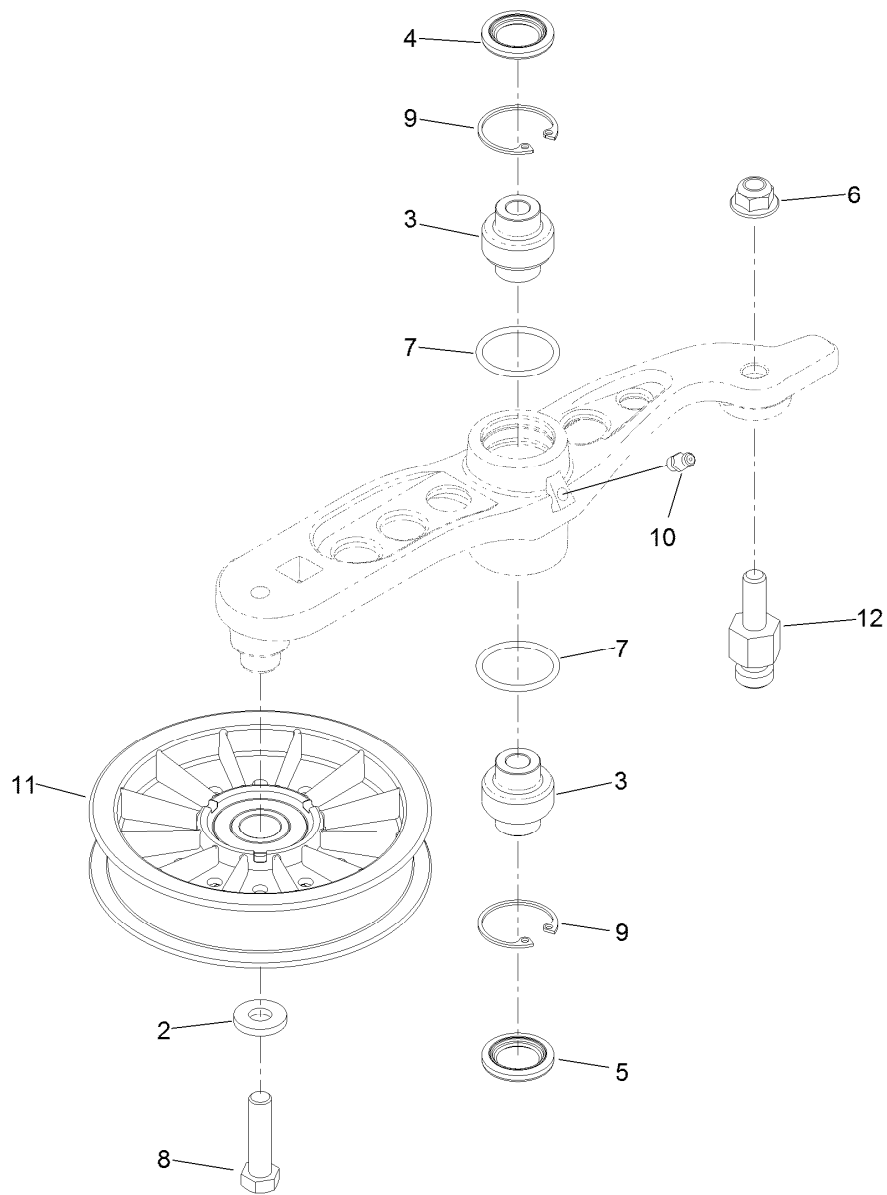

Pump Idler Assembly No. 116-1255

Ref.	Part Number	Qty.	Description
2	43-0940	1	Spacer
3	103-3504	2	Bearing-Spherical
4	103-3505	1	Seal-Double Lip
5	103-3506	1	Seal-Single Lip
6	109-6658	1	Nut-Flange, NI
7	106-7159	2	O-Ring
8	323-8	1	Screw-HH
9	32120-10	2	Ring-Snap
10	302-19	1	Fitting-Grease
11	109-8076	1	Pulley-Idler
12	116-3467	1	Pin-Spring, Anchor

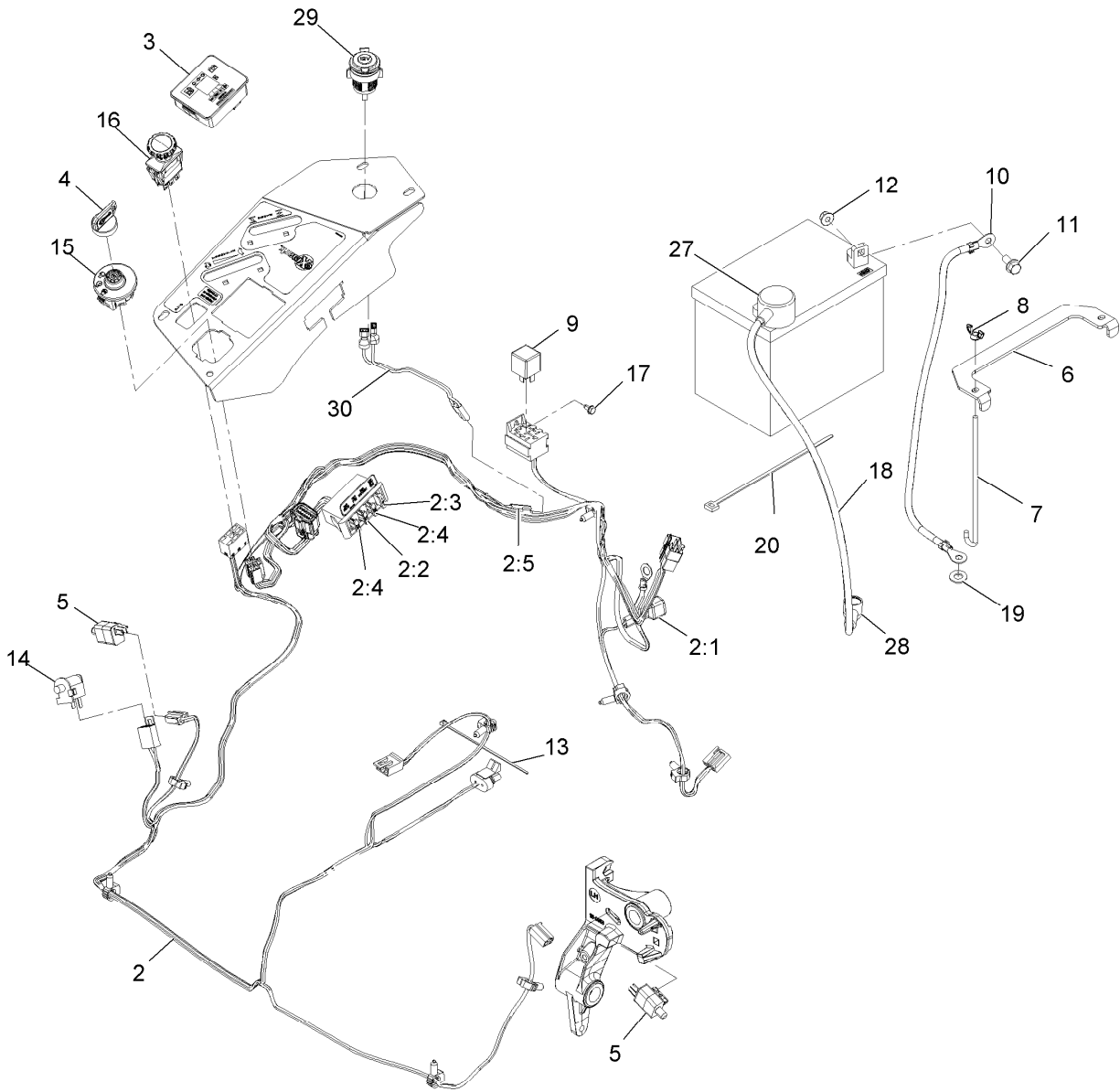

Electrical Assembly

Ref.	Part Number	Qty.	Description	Ref.	Part Number	Qty.	Description
2	116-6009	1	Harness-Wire, Main ●	11	3234-5	2	Screw-HH Flg 5/16-18 X 3/4
2:1	103-3895	1	Diode-Tvs	12	104-8300	2	Nut-Nyloc 5/16-18 Flg
2:2	218-578	1	Fuse-Blade, 10 Amp	13	1-303287	3	Tie-Cable 5 1/2 (Small)
2:3	109355	1	Fuse-Blade, 15 Amp	14	82-2190	1	Switch
2:4	109102	2	Fuse-Blade, 25 Amp	15	117-2221	1	Switch-Ignition
2:5	116-0053	1	Cap-Plug	16	116-0124	1	Switch-PTO, 10A
3	117-3882	1	Fuel/Hour Meter ASM	17	104-2065	1	Screw-HWH #10-24 X 3/8
4	1-603511	1	Key-Ignition	18	115-3864	1	Cable-Battery, Positive
4	103-2106	1	Key-Exmark Logo	19	3256-24	1	Washer-3/8 Sae
5	110-6765	2	Switch-Single Pole No	20	1-303335	1	Tie-Cable 7 15/16 (Large)
6	116-0042-03	1	Strap-Tie Down, Battery	27	109-2407	1	Insulator-Battery
7	1-633651	2	Bolt-Holddown	28	1-543393	1	Insulator-Solenoid
8	1-543792	2	Wingnut-Nyloc 1/4-20	29	109-9376	1	Receptacle, 12V
9	1-643275	1	Relay-12Vdc 40 Amp	30	109-9693	1	Harness, Receptacle 12V
10	114-1218	1	Cable-Battery, Negative				

● Use dielectric grease on all unsealed connectors and terminals only. Do not apply in sealed connectors.

Notes:

Notes:

Notes:

EXMARK® MAINTENANCE

MAXIMIZE THE PERFORMANCE OF YOUR EXMARK.

4-CYCLE PREMIUM ENGINE OIL

Part No. 116-3373

Both SAE 30 and SAE 10W-30 in one bottle.

Contains increased levels of zinc and phosphorus for better lubricity.

No Viscosity Index Improvers that tend to shear down in high heat.

Synthetic formulation.

Gas & Diesel compatible.

Anti-corrosion additives.

API 'SL' and JASO rated with wet clutch compatibility for other machines.

PREMIUM HYDRO OIL

Part No. 109-9828

Commercial quality for tough, high-heat conditions.

Designed specifically for zero-turn mower hydraulic systems.

Superior shear resistance under heavy loads.

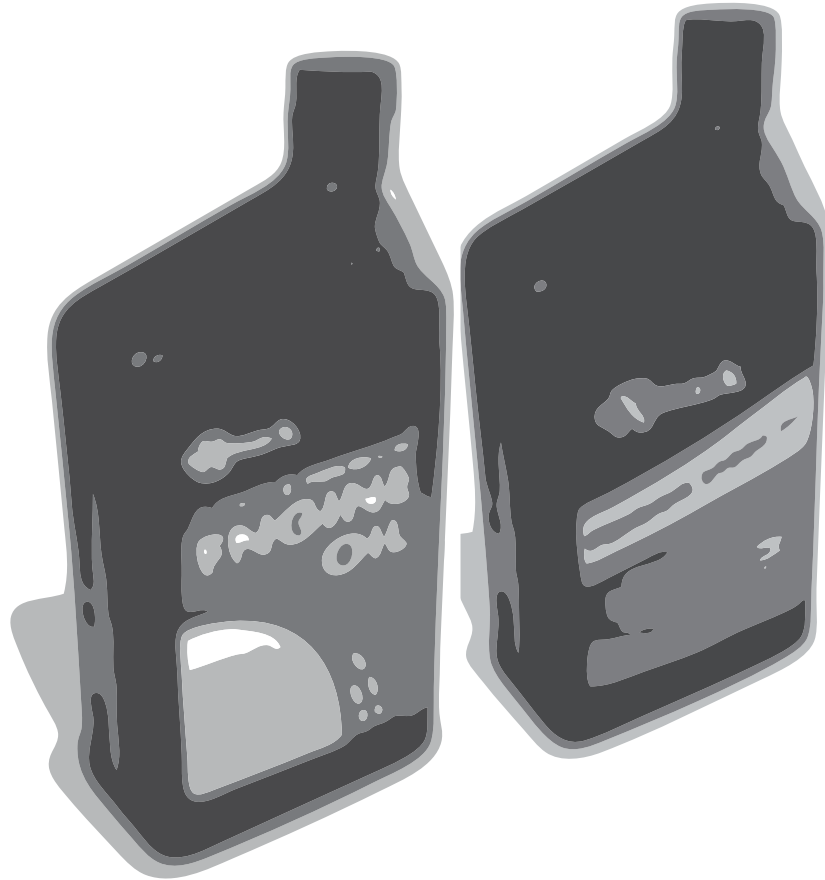

Available from your local Exmark dealer. Find your closest dealer at exmark.com

EXMARK ACCESSORIES AND OPTIONS*

MID-MOUNT RIDING ACCESSORIES AND OPTIONS

CUSTOM RIDE SEAT SUSPENSION SYSTEM	OPERATOR CONTROLLED DISCHARGE
FULL SUSPENSION SEAT	SUN SHADE
DECK LIFT ASSIST KIT	TRASH CONTAINER
HITCH KIT	TURF STRIPER
LIGHT KIT	ULTRA VAC COLLECTION SYSTEM
12V POWER PORT	ULTRA VAC QUICK DISPOSAL SYSTEM
MICRO-MULCH SYSTEM	

OUT-FRONT RIDING ACCESSORIES AND OPTIONS

CUSTOM RIDE SEAT SUSPENSION SYSTEM	SNOW BLADE
DUAL-TAIL WHEEL	SNOWBLOWER
FLOOR PAN EXTENDER	SUN SHADE
HITCH KIT	TRASH CONTAINER
LIGHT KIT	ULTRA VAC COLLECTION SYSTEM
MICRO-MULCH SYSTEM	ULTRA VAC QUICK DISPOSAL SYSTEM
ROLL OVER PROTECTION SYSTEM (ROPS)	WEATHER CAB

WALK-BEHIND ACCESSORIES AND OPTIONS

GRASS CATCHER	TURF STRIPER
MICRO-MULCH SYSTEM	STANDON

*Some accessories and options not available for some models.

Place Model No. and Serial No.
Label Here (Included in the Literature
Pack) or Fill in Below

Model No. _____

Serial No. _____

Date Purchased _____

Engine Model No. and Spec. No. _____

Engine Serial No. (E/No) _____

© 2013 Exmark Mfg. Co., Inc.
Industrial Park Box 808
Beatrice, NE 68310
All Rights Reserved

Part No. 4501-416 Rev. A
(402) 223-6300
Fax (402) 223-5489
Printed in the USA.

