

# **TURF TRACER<sup>®</sup>**

## **S-SERIES**

**Model No. TTS541KA483CA—Serial No. 31200000 and Up**

Picture below may not reflect actual product.

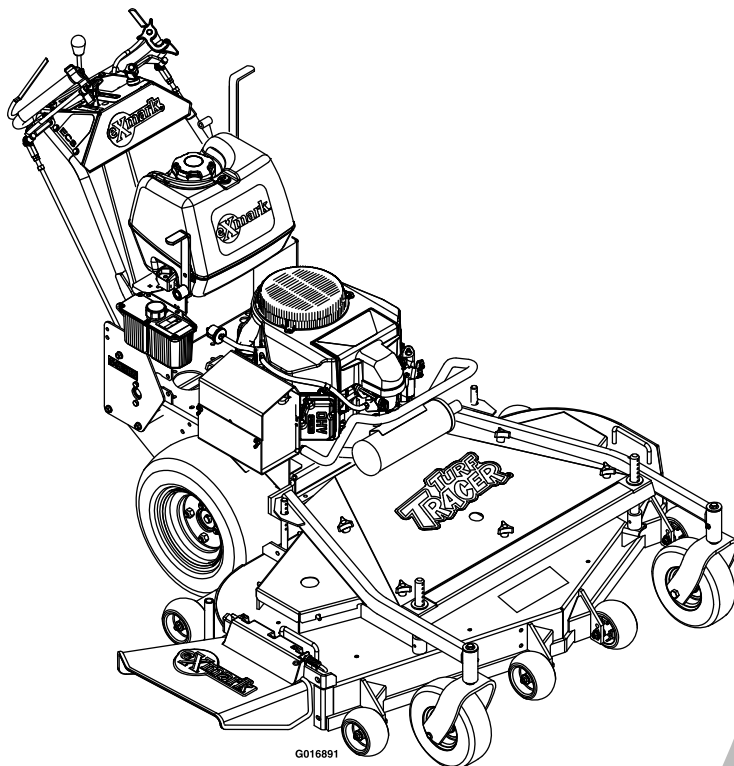

G016891

# **Parts Manual**

Part No. 4500-960 Rev. A

# Ordering Replacement Parts

To order replacement parts, please supply the part number, the quantity, and the description of each part desired.

## Understanding Reference Numbers

Each identified part in an illustration has a reference number. The reference number for a part also appears in the parts list, along with other information about the part.

This catalog uses two special reference number formats, one to indicate parts in a service assembly and another to indicate the quantity of a given part in an illustration.

## Service Assembly Reference Numbers

Parts in service assemblies have reference numbers in the form a:b. The a represents the reference number of the entire service assembly and the b represents a sequential number unique to each part within the service assembly.

For example, a wheel assembly might be identified by reference number 6, the tire by 6:1, the valve by 6:2, and the wheel by 6:3. When you order the assembly identified by reference number 6, you receive all parts identified by reference numbers 6:1, 6:2, and 6:3. However, you may also order any part individually. Reference numbers of this type appear in illustration and in parts lists.

## Reference Numbers Indicating Quantity

In an illustration, if a reference number indicates more than one part, the reference number has the form nX y. The n represents the quantity of the part, the X is the multiplication symbol, and the y represents the reference number.

For example, in an illustration, the reference number 2X 37 means that two of the parts identified by reference number 37 are indicated.

# List of Abbreviations

<b>AR:</b> as required	<b>HJ:</b> hex jam	<b>PTH:</b> phillips truss head
<b>ASM:</b> assembly	<b>HLH:</b> hex lag head	<b>PTO:</b> power-take-off
<b>BBC:</b> blade brake control	<b>HOC:</b> height-of-cut	<b>RH:</b> right hand
<b>BHTF:</b> button head thread forming	<b>HSBH:</b> hex socket button head	<b>ROPS:</b> roll-over protection system
<b>CARR:</b> carriage	<b>HSFH:</b> hex socket flat head	<b>RRB:</b> rear roller brush
<b>CCW:</b> counter clockwise	<b>HSH:</b> hex socket head	<b>SFH:</b> slotted fillister head
<b>CW:</b> clockwise	<b>HWH:</b> hex washer head	<b>SHH:</b> slotted hex head
<b>DEG:</b> degrees	<b>HWHTF:</b> hex washer head thread forming	<b>SHWH:</b> slotted hex washer head
<b>DPA:</b> Dual Point Adjustment	<b>HYD:</b> hydraulic	<b>SPH:</b> slotted pan head
<b>ECM:</b> electronic control module	<b>LH:</b> left hand	<b>SQH:</b> square head
<b>EXT:</b> external	<b>LPG:</b> Liquid Propane Gas	<b>SRH:</b> slotted round head
<b>FH:</b> flat head	<b>NI:</b> nylon insert	<b>STD:</b> standard
<b>GA:</b> gauge	<b>NPTF:</b> national pipe thread fine	<b>TAP:</b> self tapping
<b>HD:</b> heavy-duty	<b>PFH:</b> phillips flat head	<b>TTH:</b> torx truss head
<b>HF:</b> hex flange	<b>PPH:</b> phillips pan head	
<b>HH:</b> hex head	<b>PPHTF:</b> phillips pan head thread forming	
<b>HHF:</b> hex head flange	<b>PRH:</b> phillips round head	
<b>HHFTF:</b> hex head flange thread forming		

# Touch Up Paint

Exmark black touch up spray paint – gloss black.

Exmark red touch up paint (spray paint – P/N 1-850337 - .6 oz liquid bottle – P/N 103-9140).



If your Exmark dealer does not have the Exmark part in stock, Exmark will get the parts to the dealer the next business day or the part will be FREE Guaranteed!! (Some restrictions apply. See your participating Exmark Dealer for details.)

## Contents

Mower Deck Assembly .....	4
Engine Deck Assembly .....	6
Engine Deck Assembly (cont.) .....	8
ECS Upper Handles and Controls Assembly .....	10
Fuel Tank Assembly .....	12
Electrical Assembly .....	13
Decals .....	14
Hydraulic Assembly .....	16

# Mower Deck Assembly

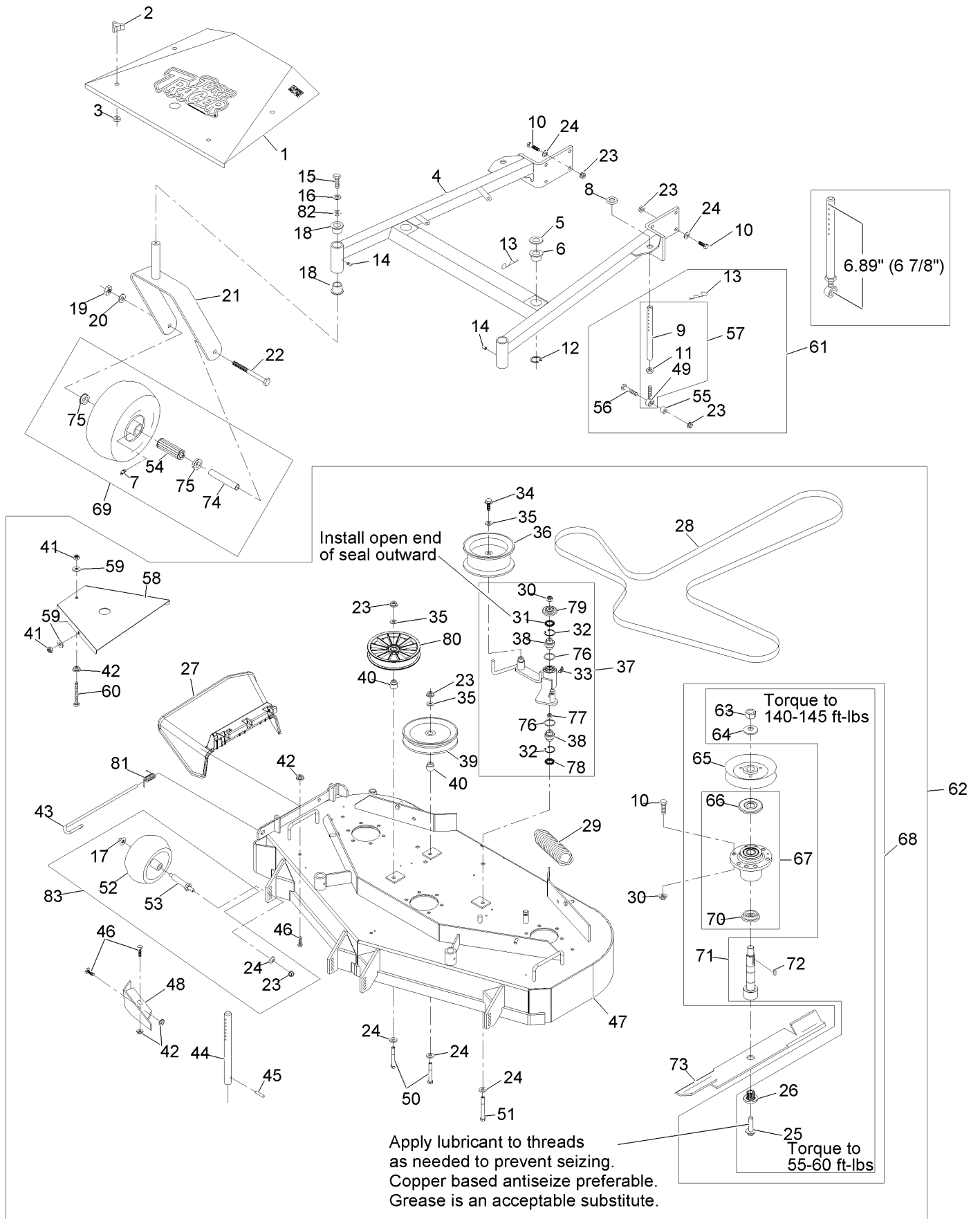

## Mower Deck Assembly (continued)

<i>Ref.</i>	<i>Part Number</i>	<i>Qty.</i>	<i>Description</i>	<i>Ref.</i>	<i>Part Number</i>	<i>Qty.</i>	<i>Description</i>
1	116-2711	1	Shield, Belt (1-413101-01) W/Decals	45	1-806332	2	Rollpin 1/4 X 1 1/2
2	1-323385	4	Knob-3 Prong	46	322-2	3	Screw-HH
3	1-323417	4	Washer	47	1-414384	1	Wld, Deck (116-2457-01) W/Decals, Discharge Baffle & Support Rods
4	1-414310	1	Wld, Support (1-412110-01) W/Bushings & Decals	48	116-2297-01	1	Baffle, Discharge
5	1-413425	2	Spacer	49	1-613204	2	Balljoint
6	1-513336	2	Bushing-Deck	50	323-13	2	Screw-HH
7	302-61	2	Fitting-Grease	51	98-5961	1	Screw-HH
8	1-323539	2	Spacer	52	1-603299	4	Roller-Scalp, Anti
9	1-413525	2	Link, Rear Deck Support	53	99-2842	4	Spacer
10	323-7	26	Screw-HH	54	1-513809	2	Bearing
11	3220-3	2	Nut-HJ	55	1-603050	2	Spacer
12	32120-33	2	Ring-Retaining	56	323-9	2	Screw-HH
13	1-806009	4	Hairpin, Cotter #206	57	1-414521	2	Link, Assembly
14	302-52	2	Fitting-Grease	58	103-2970-01	2	Shield, Belt
15	323-6	2	Screw-HH	59	3256-3	6	Washer-Flat
16	3253-5	2	Washer-Lock	60	1-800017	2	Bolt, HH 5/16-18 X 3 1/4 Tap
17	109-6658	4	Nut-Flange, NI	61	1-411532	2	Kit, Support Link W/Pin
18	1-303514	4	Bearing-Flanged	62	103-0321	1	Asm, Deck Complete
19	3217-9	2	Nut-HH	63	3217-46	3	Nut-HH
20	3253-7	2	Washer-Lock	64	103-2802	3	Washer
21	1-522143-01	2	Wld, Caster	65	1-413424	3	Sheave W/ Hub ▲
22	325-20	2	Screw-HH	66	103-1330	3	Guard-Bearing, Top ▲
23	3290-357	13	Nut-HHF, Whiz	67	103-8280	3	Kit, Cutter Housing
24	98-5975	15	Washer-Belleville	68	103-9081	3	Asm, Cutter Housing Complete
25	109-9220	3	Screw,Sems (1/2-20 X 2.19, Gr5)	69	103-2171	2	Kit, Tire & Wheel Asm W/ Spacer
26	103-3037	3	Bushing,Splined	70	103-2535	3	Spacer-Guard, Bottom
27	109-5151	1	Cht Disch Xrk M056	71	103-9071	3	Kit, Spindle ▲
28	1-413093	1	Belt - V, B	72	1-807268	3	Key-Rectangle
29	103-3330	1	Spring-Extension	73	103-6401	3	Blade-Notched ■
30	3296-39	19	Nut-Lock, NI	73	103-6391	3	Blade, Mulching (48
31	103-3506	1	Seal-Single Lip	73	103-6386	3	Blade, Low Lift (48
32	32120-10	2	Ring-Snap	73	103-6381	3	Blade, Solid (48
33	302-40	1	Fitting-Grease	73	116-5177	3	Blade-Extreme 2, 16.25"
34	3234-11	1	Screw-HHF	74	1-513547	2	Spacer
35	3256-24	3	Washer-Flat	75	1-513810	4	Bushing
36	1-413099	1	Pulley-Idler	76	106-7159	2	O-Ring
37	103-8585	1	Kit, Idler Arm (103-7356-03) W/Brgs ●	77	103-5677	1	Spacer
38	103-3504	2	Bearing-Spherical	78	103-3505	1	Seal-Double Lip
39	1-613098	1	Pulley-Idler	79	103-2916	1	Guard-Top
40	1-413113	2	Bushing-Idler	80	109-0977	1	Pulley,Idler 5"
41	3296-29	6	Nut-Lock, NI	81	116-0962	1	Spring, Torsion
42	32128-20	3	Nut-HF	82	1-373034	2	Washer
43	109-8854	1	Pin-Chute	83	103-4051	1	Kit,Anti-Scalp Roller
44	1-603001	2	Rod, Deck Support				

● Assembly also includes Washer and Screw

■ Requires installation of mulch kit for proper mulching. See your Exmark dealer for details.

▲ Apply Mobil HTS grease (P/N 103-5217 1.5 oz packet) (or a food-grade anti-seize). See operator s manual for locations.

# Engine Deck Assembly

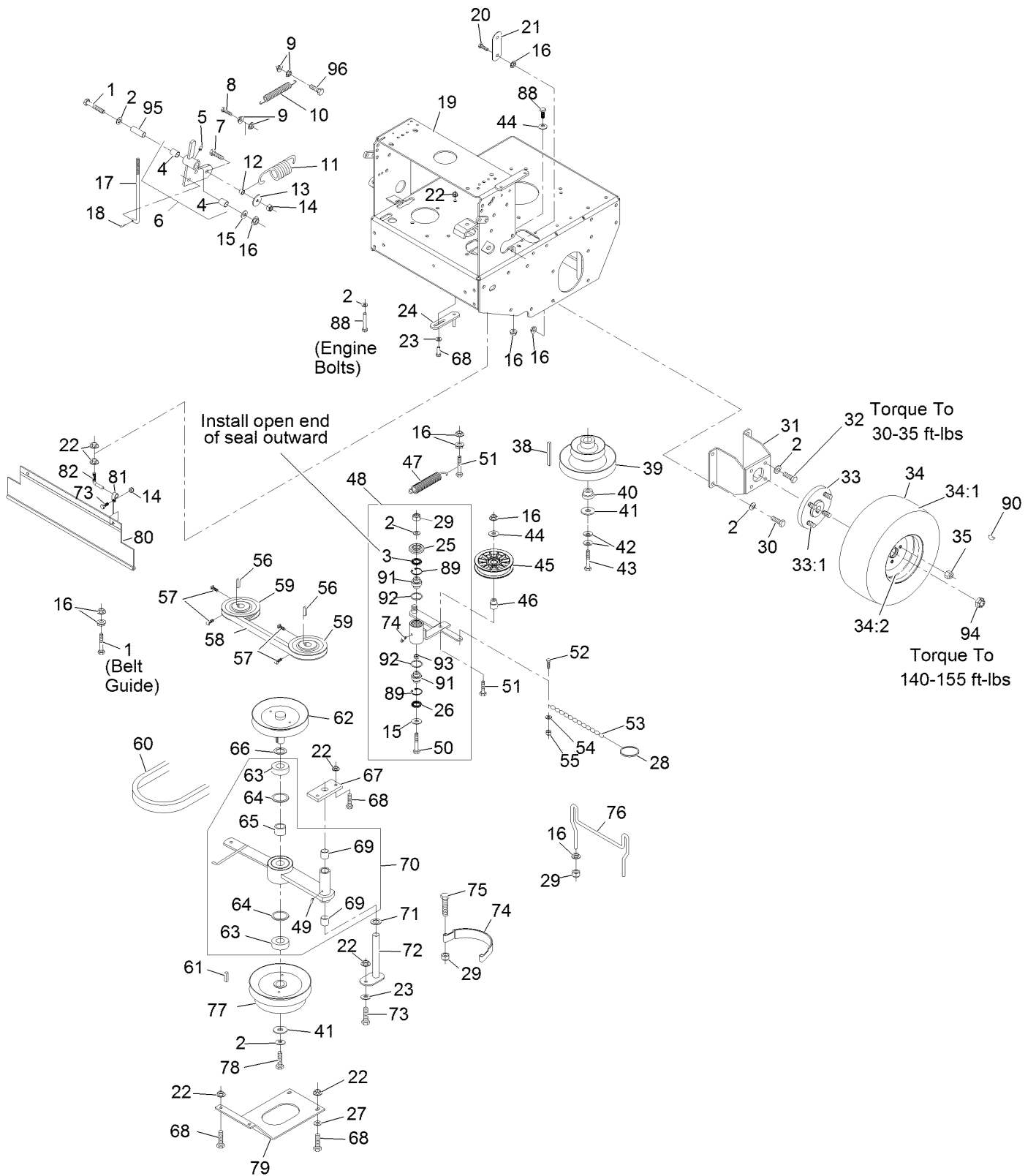

## Engine Deck Assembly (continued)

Ref.	Part Number	Qty.	Description	Ref.	Part Number	Qty.	Description
1	323-11	2	Screw-HH 3/8-16 X 2 1/4	45	109-4077	1	Pulley-Idler, Flat
2	98-5975	23	Washer-Spring Disc 3/8	46	1-603496	1	Bushing-Idler
3	103-3506	1	Seal-Single Lip	47	103-8599	1	Spring, Extension
4	1-513034	2	Sleeve-Bearing	48	109-1296	1	Kit, Idler Arm (109-1208-03) W/Brgs
5	302-19	1	Zerk-1/4-28 Str	49	1481	2	Zerk-45° 1/4-28
6	1-414143	1	Asm, Bellcrank (1-412285-03) W/Brgs	50	98-5961	1	Screw-HH 3/8-16 X 4 Gr8
7	322-6	1	Screw-HH 5/16-18 X 1 1/4	51	323-9	2	Screw-HH 3/8-16 X 1 3/4
8	321-6	1	Screw-HH 1/4-20 X 1	52	1-809069	1	Screw-HSH #10-24 X 7/8
9	32128-33	4	Nut-Whizlock 1/4-20	53	1-323365	1	Chain-Link, Twist
10	1-523498	1	Spring, Motion Control	54	3256-14	1	Washer-#10 Std
11	103-7398	1	Spring, Belt Tension	55	3296-2	1	Nut-Nyloc #10-24
12	1-543007	1	Spacer	56	1-807272	2	Key-5Mm X 5Mm X 25Mm
13	1-213069	1	Washer	57	1-803050	4	Setscrew-5/16-18 X 3/4 ■
14	3296-29	3	Nut-Nyloc 5/16-18	58	109-1057	1	Belt, Pump Drive
15	3256-4	2	Washer-3/8 Std	59	1-413010	2	Sheave ASM ●
16	3290-357	19	Nut-Whizlock 3/8-16	60	103-6317	1	Belt, Blade Clutch
17	1-413282	1	Linkage	61	1-807259	1	Key-Machine 1/4 X 1/4 X 1
18	1-806003	1	Hairpin-Cotter	62	103-6308	1	Sheave W/Shaft ●
19	116-6129	1	Asm, Deck (116-6080-01) W/Decals	63	1-413111	2	Bearing, Clutch ●
20	323-4	2	Screw-HH 3/8-16 X 3/4	64	32120-8	2	Ring-Retaining
21	1-633068	1	Arm-Lift, Deck	65	1-413012	1	Spacer, Bearing
22	32128-20	11	Nut-Whizlock 5/16-18	66	1-523157	1	Washer
23	1-303334	2	Washer-Spring Disc 5/16	67	1-413049-01	1	Plate, Clutch Pivot
24	1-322110	1	Guide-Belt	68	322-5	7	Screw-HH 5/16-18 X 1
25	103-2916	1	Guard-Top	69	1-413207	2	Pivot, Bearing
26	103-3505	1	Seal-Double Lip	70	1-414418	1	Asm, Clutch Arm (1-412417-03) W/Bearings
27	3256-3	2	Washer-5/16 Std	71	1-413235	1	Washer, Spacer
28	1-323366	1	Ring-Split	72	1-412138-03	1	Wld, Pivot Pin
29	3296-39	5	Nut-Nyloc 3/8-16	73	322-3	3	Screw-HH 5/16-18 X 3/4
30	323-6	8	Screw-HH 3/8-16 X 1	74	1-413062	1	Band, Brake
31	1-412082-01	2	Mount, Wheel Motor (48& 52)	75	323-8	2	Screw-HH 3/8-16 X 1 1/2
32	323-6	8	Screw-HH 3/8-16 X 1	76	103-6310	1	Wld, Belt Guide
33	112-9049	2	Wheel Hub ASM	77	1-412028	1	Sheave W/Drum ●
33:1	1-633926	8	Stud-Wheel	78	1-800521	1	Screw-HH 3/8-24 X 1 ■
34	1-613263	2	Wheel And Tire ASM	79	1-413009-01	1	Plate, Guard
34:1	1-613264	2	Tire-Turfmaster	80	103-2056	1	Shield-Drag
34:2	1-603715	2	Wheel-Rim	81	1-413510	2	Clip-Loom
35	242-50	8	Nut-Lug 1/2-20	82	1-413511	2	Hanger, Drag Shield
38	1-807264	1	Key-Machine 1/4 X 1/4 X 2 5/8	88	323-7	5	Screw-HH 3/8-16 X 1 1/4
39	103-6309	1	Asm, Drive Sheave ●	89	32120-10	2	Ring-Retaining
40	1-603609	1	Bushing	90	1-807019	2	Key-Woodruff 1 X 1/4
41	1-373034	2	Washer	91	103-3504	2	Bearing-Spherical
42	1-603610	2	Washer-Spring Disc 7/16	92	106-7159	2	O-Ring
43	3212-10	1	Screw-HH 7/16-20 X 2 1/2 ■	93	103-5677	1	Spacer
44	3256-24	2	Washer-3/8 Sae	94	116-2839	2	Nut-Lock
				95	1-603044	1	Bushing
				96	321-8	1	Screw-HH 1/4-20 X 1 1/4

● Apply anti-seize compound in bore.

■ Use Pro-Lock, Nut Type (P/N 1-840022, .5ml tube) on threads.





## Engine Deck Assembly (cont.) (continued)

<i>Ref.</i>	<i>Part Number</i>	<i>Qty.</i>	<i>Description</i>	<i>Ref.</i>	<i>Part Number</i>	<i>Qty.</i>	<i>Description</i>
1	1-323245	1	Spring-Compression	40	3256-24	4	Washer-3/8 Sae
2	32128-20	20	Nut-Whizlock 5/16-18	41	103-3060	1	Knob-Tracking
3	3296-29	2	Nut-Nyloc 5/16-18	42	1-323161	1	Spring
4	1-613089	2	Tab-Spring, Extension	43	103-2004-03	1	Brake
5	1-603693	2	Spring	46	1-413492	1	Linkage, Upper Brake
6	110-4897-01	2	Shield-Control	47	323-23	1	Screw-HH 3/8-16 X 4-1/2
7	323-16	6	Screw-HH 3/8-16 X 4	48	3296-39	2	Nut-Nyloc 3/8-16
8	302-19	2	Zerk-1/4-28 Str	49	103-1148	2	Rod, Drive Lever
9	322-3	4	Screw-HH 5/16-18 X 3/4	50	323-8	2	Screw-HH 3/8-16 X 1 1/2
10	1-805005	4	Washer-Lock 5/16 Heavy	51	103-1167	2	Joint-Ball End, .38X.38Fe LH
11	3256-2	6	Washer-1/4 Std	52	103-1166	2	Spacer-Tube, Pump Link
12	3290-357	15	Nut-Whizlock 3/8-16	53	114-3549	4	Nut-M8
13	1-323195-01	4	Spacer-Shield	54	323-16	1	Screw-HH 3/8-16 X 4
14	1-633102	2	Bearing-Flanged	55	1-303020	1	Grip-Lever
15	1-323197-01	4	Spacer-Shield	56	323-9	2	Screw-HH 3/8-16 X 1 3/4
16	1-603737	2	Bolt-Neutral Return	57	323-4	3	Screw-HH 3/8-16 X 3/4
17	103-0265	2	Spring, Neutral Return	58	103-3495	1	Lever, Brake (1-412501-03) W/Decal & Grip
18	1-603735	2	Bushing-Flanged	59	1-414504	1	Bracket ASM
19	3219-2	7	Nut-Hex 5/16-24	60	1-413347	2	Sleeve-Bushing
20	1-303105	2	Yoke-Adjustable	61	1-413344	1	Bushing-Pivot
21	1-808280	2	Pin-Clevis 5/16 X 1 49/64	62	323-10	1	Screw-HH 3/8-16 X 2
22	1-806003	5	Hairpin-Cotter	63	1-414508	1	Bellcrank ASM
23	3220-2	2	Nut-Jam 5/16-24	64	1-303548	1	Bushing-Plastic
24	1-413350	2	Link-Control, Speed	65	32128-21	1	Nut-3/8-16 Flanged Side Lock
25	1-412203-01	1	Crank-Control, Speed	66	103-2399	1	Pin-Clevis Spring 3/8
26	1-633131	1	Yoke-Linkage, Brake	67	3218-2	2	Nut-Jam 5/16-18
27	3256-23	7	Washer-5/16 Sae	68	1-643312	1	Clip-Loom
28	1-603676	2	Swivel-Adjustable, Short	69	116-3735	1	Muffler,Horizontal
29	1-800016	2	Bolt-HH 5/16-18 X 1 1/4 Tap	70	1-653313	2	Gasket-Exhaust
30	1-413489	1	Linkage-Lower	71	114-3550	4	Washer-Lock, Spring
31	1-803022	2	Setscrew-5/16-18 X 5/8 ■	72	116-5052	1	Asm-Oil Drain Hose W/Plug ●
32	103-1190-01	1	Shaft-Control, LH	73	353-508	1	Plug-W/O-Ring
33	103-4796-01	1	Shaft-Control, RH	74	237-42	1	O-Ring
34	3218-3	1	Nut-Jam 3/8-16	75	116-6278-03	1	Guard-Muffler
35	116-3515	3	Screw,HH Special 5/16-18 X 1.25	76	323-6	4	Screw-HH 3/8-16 X 1
36	3272-5	2	Pin-Cotter 3/32 X 1/2	77	104-8301	4	Nut-Nyloc 3/8-16 Flg
37	1-603903	1	Spacer				
38	1-403180	2	Screw-HH 5/16-18 X 1 1/4 Sp				
39	1-809056	2	Screw-Sh 5/16-18 X 1 3/8 ■				

● Use a Teflon Pipe Sealant or equivalent on threads.

■ Use Pro-Lock, Nut Type (P/N 1-840022, .5ml tube) on threads.

# ECS Upper Handles and Controls Assembly

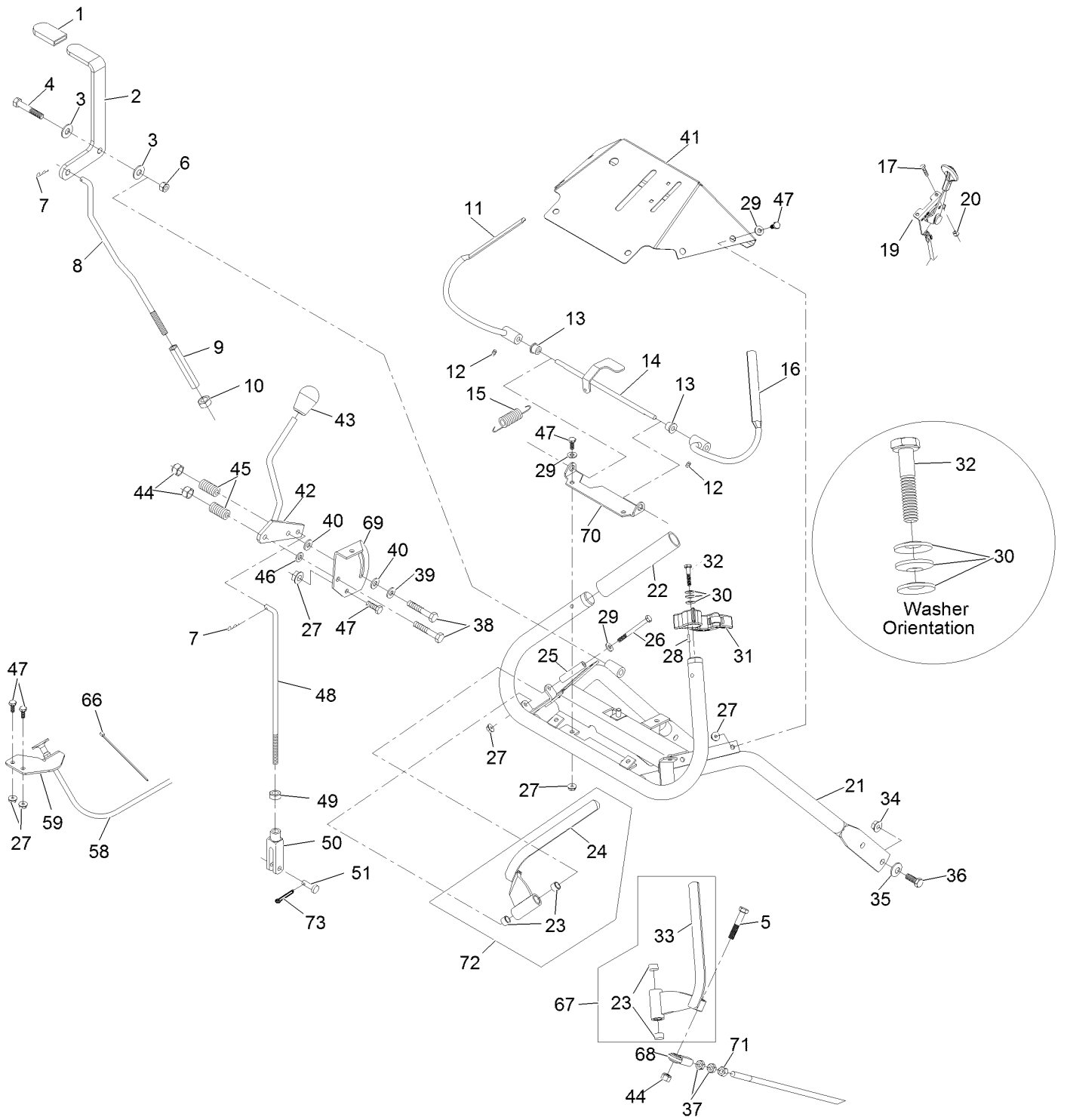

## ECS Upper Handles and Controls Assembly (continued)

<i>Ref.</i>	<i>Part Number</i>	<i>Qty.</i>	<i>Description</i>	<i>Ref.</i>	<i>Part Number</i>	<i>Qty.</i>	<i>Description</i>
1	1-303020	1	Grip-Lever	32	103-0235	2	Screw-HH 1/4-20 X 1 1/8 W/Nylon ●
2	116-6334	1	Asm, Lever (116-1736-03) W/Grip	33	116-4082-03	1	Lever, Drive (RH)
3	3256-4	2	Washer-3/8 Std	34	3290-357	4	Nut-Whizlock 3/8-16
4	323-11	1	Screw-HH 3/8-16 X 2 1/4	35	98-5975	4	Washer-Spring Disc 3/8
5	322-9	2	Screw-HH 5/16-18 X 1 3/4	36	323-6	4	Screw-HH 3/8-16 X 1
6	3296-39	1	Nut-Nyloc 3/8-16	37	3220-3	4	Nut-Jam 3/8-24
7	1-806003	2	Hairpin-Cotter	38	322-10	4	Screw-HH 5/16-18 X 2
8	103-1149	1	Link, Blade Engagement	39	1-603716	1	Washer-Friction Disc
9	1-413279	1	Turnbuckle	40	1-323244	2	Washer-Friction
10	3217-7	1	Nut-Hex 3/8-16	41	109-4651	1	Asm, Console (109-4649-03)W/ Decals
11	116-4079	1	Wld, Lever, Opc (LH) ■	42	116-4083	1	Wld, Speed Shift
12	1-803322	2	Setscrew-5/16-24 X 5/16 ●	43	103-0423	1	Knob-Nyloc 3/8-16
13	1-303365	2	Bushing-Nylon	44	3296-29	4	Nut-Nyloc 5/16-18
14	103-0769-03	1	Wld, Opc Axle Lever	45	1-323245	2	Spring-Compression
15	1-303363	1	Spring-Extension	46	3256-23	1	Washer-5/16 Sae
16	116-4080	1	Wld, Opc Lever (RH) ■	47	321-3	12	Screw-HH 1/4-20 X 5/8
17	1-807513	2	Bolt-Carriage #10-24 X 1/2	48	1-413225	1	Rod, Speed Control
19	116-2426	1	Cable, Throttle	49	3220-2	1	Nut-Jam 5/16-24
20	3296-2	2	Nut-Nyloc #10-24	50	1-303105	1	Yoke-Adjustable
21	103-0770-03	1	Wld, Handle	51	1-808280	1	Pin-Clevis 5/16 X 1 49/64
22	103-0815	2	Grip-Bar, Handle	58	103-1796	1	Cable-Choke
23	1-413152	4	Bushing-Sleeve	59	103-1797-01	1	Bracket-Cable, Choke
24	116-4081-03	1	Lever, Drive (LH)	66	1-303287	1	Tie-Cable 5 1/2 (Small)
25	103-0027	2	Bushing-Lever, Drive	67	103-2513	1	Asm, Drive Lever RH
26	321-14	2	Screw-HH 1/4-20 X 2 3/4	68	103-2463	2	Balljoint
27	32128-33	14	Nut-Whizlock 1/4-20	69	103-0503	1	Bracket, Shifter Slide
28	103-0464	2	Pin-Spring 1/8 X 1/2	70	103-0489-03	1	Bracket, Opc Axle
29	3256-22	10	Washer-1/4 Sae	71	3219-3	2	Nut-Hex 3/8-24
30	1-303435	6	Washer-Spring Disc 1/4	72	103-2514	1	Asm, Drive Lever LH
31	103-1371	1	Thumb Latch Asm RH(Shown)	73	3272-5	1	Pin-Cotter 3/32 X 1/2
31	103-1372	1	Thumb Latch Asm LH(Not Shown)				

● Use Pro-Lock, Nut Type (P/N 1-840022, .5ml tube) on threads.

■ Use Pro-Lock retaining type, Part no. 1-840023 (.5cc tube) on inside of bore of OPC hub.



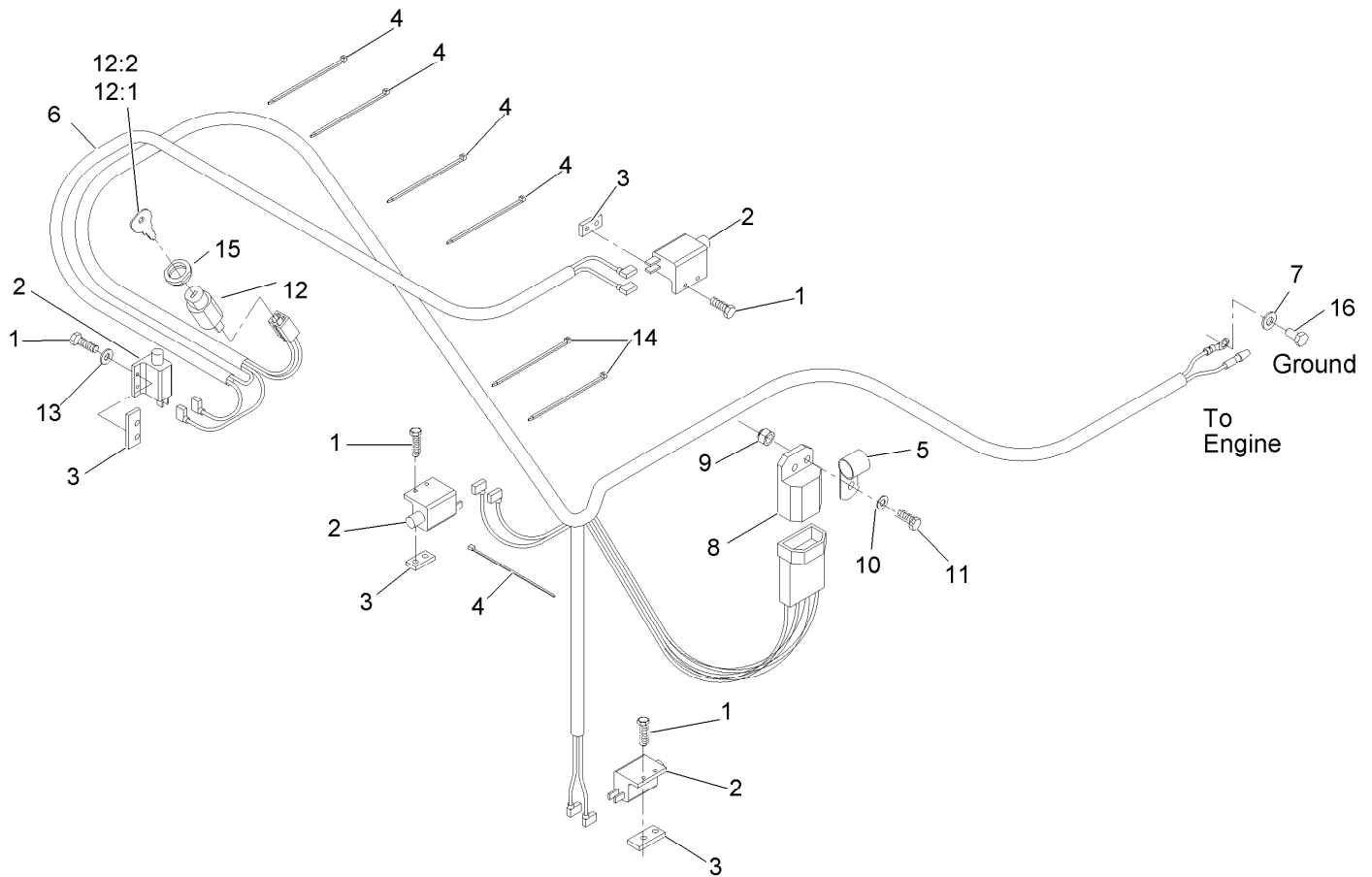

## Electrical Assembly

<i>Ref.</i>	<i>Part Number</i>	<i>Qty.</i>	<i>Description</i>	<i>Ref.</i>	<i>Part Number</i>	<i>Qty.</i>	<i>Description</i>
1	3290-500	8	Screw-PPH #10-24 X 5/8	10	3256-22	1	Washer-1/4 Sae
2	1-513051	4	Switch-N.O.	11	321-4	1	Screw-HH 1/4-20 X 3/4
3	1-633181	4	Plate-Tapped	12	1-403121	1	Switch-Key
4	1-303287	5	Tie-Cable 5 1/2 (Small)	12:1	1-603511	1	Key-Ignition
5	1-323229	1	Clip-Loom 3/8	12:2	103-2106	1	Key-Exmark Logo
6	116-2610	1	Harness, Wiring	13	3256-14	1	Washer-#10 Std
7	33094-00	1	Washer	14	1-303335	2	Tie-Cable 7 15/16 (Large)
8	1-323430	1	Module-Interlock	15	103-0498	1	Nut-Ignition
9	3296-42	1	Nut-Nyloc 1/4-20	16	33114-016	1	Screw-HH M8-1.25 X 16Mm

# Decals

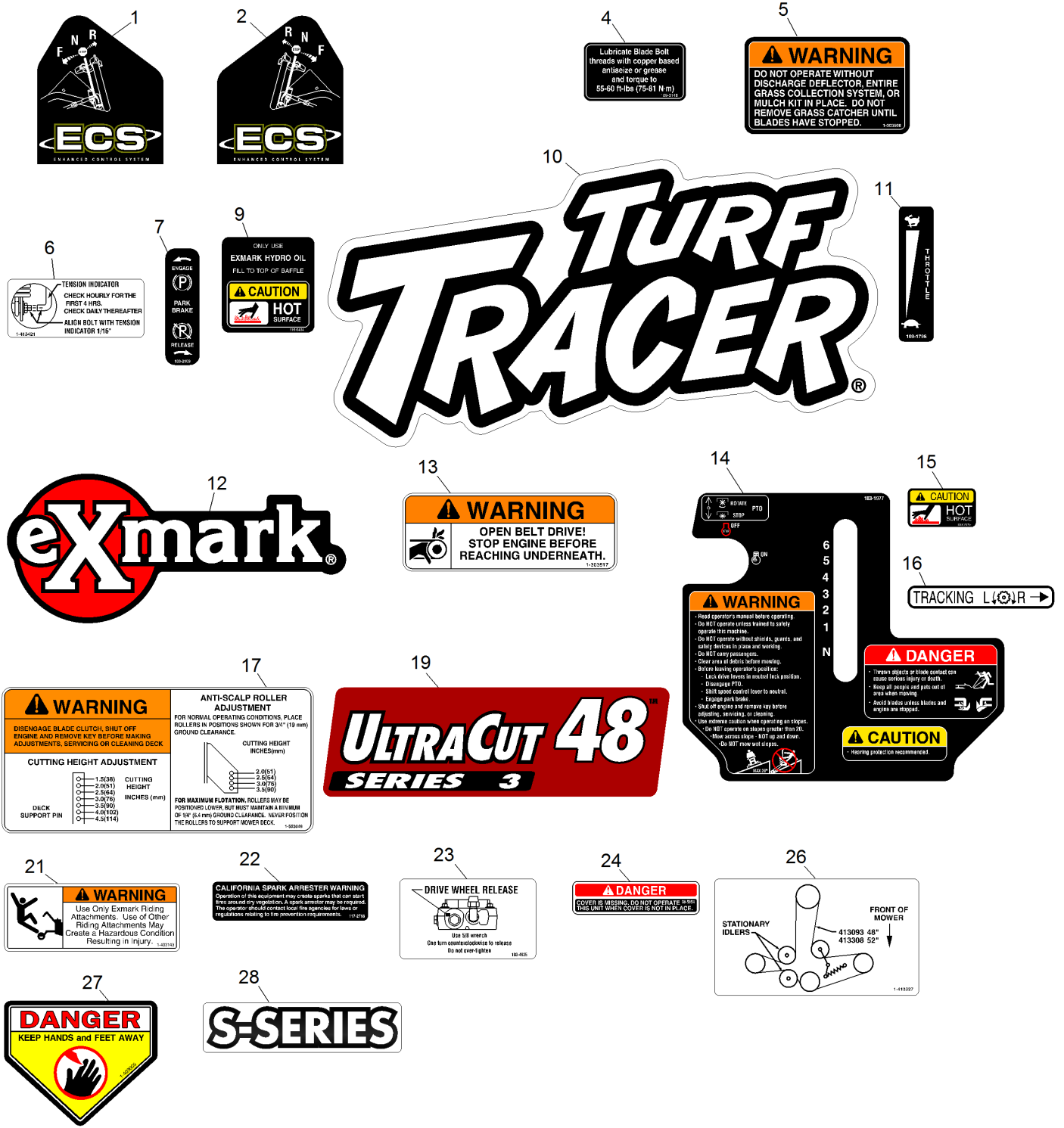

## Decals (continued)

<i>Ref.</i>	<i>Part Number</i>	<i>Qty.</i>	<i>Description</i>	<i>Ref.</i>	<i>Part Number</i>	<i>Qty.</i>	<i>Description</i>
1	103-2242	1	Decal, LH Ecs Instruction	15	103-2076	2	Decal-Caution
2	103-2243	1	Decal, RH Ecs Instruction	16	1-413214	1	Decal, Tracking
4	109-3148	1	Decal,Bolt Torque	17	1-553049	1	Decal-Anti Scalp
5	1-303508	1	Decal-Warning, Discharge	19	116-4697	1	Decal-Ultracut 48 Series 3
6	1-413421	1	Decal, Indicator	21	1-403143	1	Decal,Sulky Warning
7	103-2103	1	Decal-Brake, Park	22	117-2718	1	Decal-Arrester, Spark
9	116-0404	1	Decal-Hydraulic Tank	23	103-4935	1	Decal, Drive Wheel Release
10	103-3013	1	Decal-Turf Tracer	24	98-5954	3	Decal-Cover, Missing
11	103-1798	1	Decal, Throttle	26	1-413327	1	Decal, Belt Routing
12	103-2882	1	Decal,Exmark Logo	27	1-403005	2	Decal-Danger
13	1-303517	1	Decal,Belt Drive	28	116-3884	2	Decal-S-Series
14	103-1977	1	Decal, Ecs Console	99	103-2461	1	Decal Kit ●

● Not illustrated

# Hydraulic Assembly

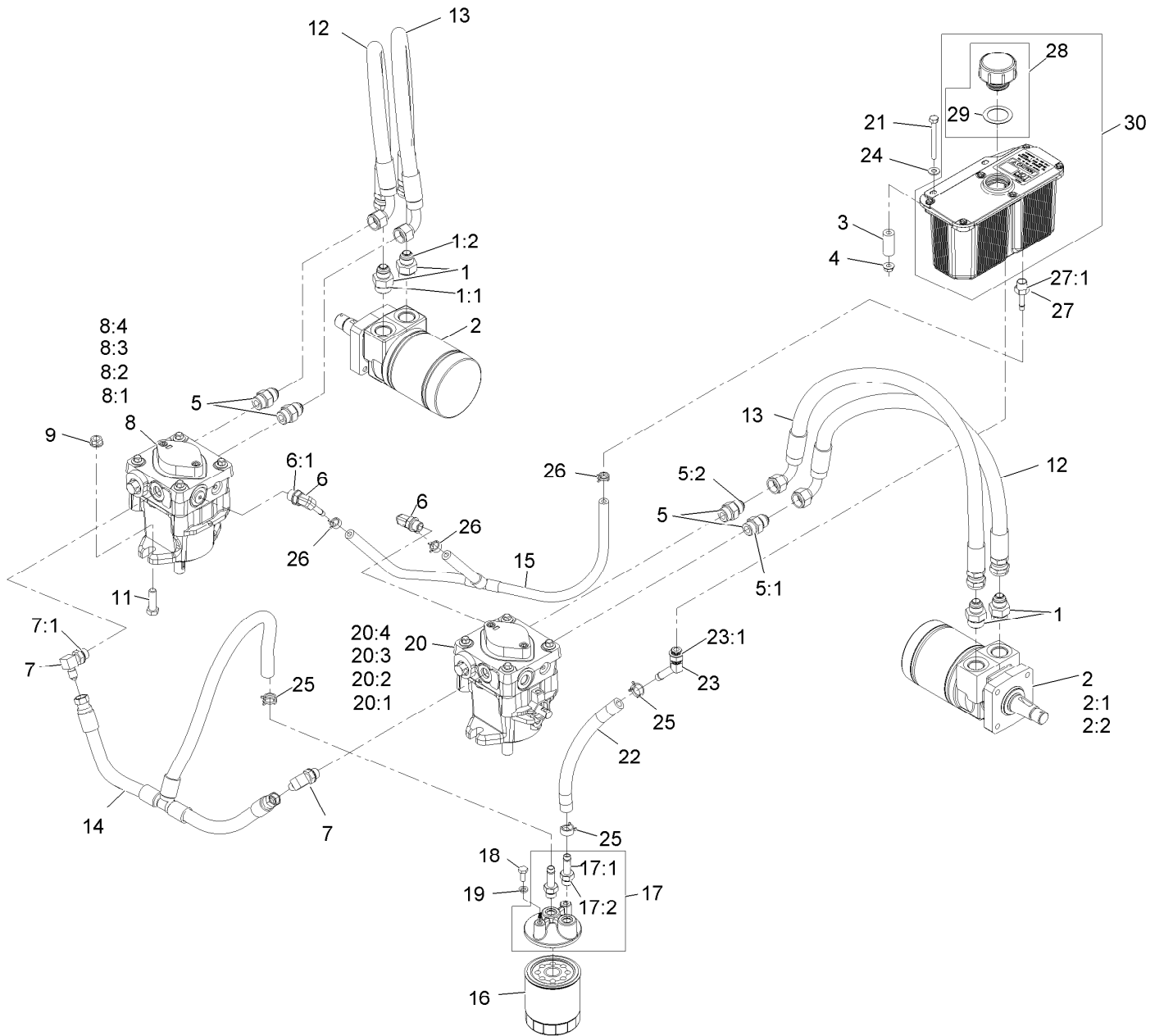



## Hydraulic Assembly (continued)

<i>Ref.</i>	<i>Part Number</i>	<i>Qty.</i>	<i>Description</i>	<i>Ref.</i>	<i>Part Number</i>	<i>Qty.</i>	<i>Description</i>
1	1-603991	4	Adapter-Straight	16	109-4180	1	Filter,25 Micron
1:1	1-603919	1	O-Ring-Sae #10				Bi-Directional
1:2	1-603992	1	O-Ring-37 Flare #8	16	1-523541	1	Element, Oil Filter(Winter) ●
2	1-603718	2	HYD Motor ASM	17	103-2889	1	Filter Head ASM
2:1	1-000138	1	Bearing And Seal Kit	17:1	103-1912	2	Adapter-Straight
2:2	1-000119	1	Seal Kit	17:2	1-603921	1	O-Ring-Sae #6
3	103-2191	2	Spacer	18	321-3	2	Screw-HH 1/4-20 X 5/8
4	32128-33	2	Nut-Whizlock 1/4-20	19	1-805004	2	Washer-Lock 1/4 Heavy
5	1-603990	4	Adapter-Straight	20	116-0943	1	RH HYD Pump ASM
5:1	1-603920	1	O-Ring-Sae #8	20:1	103-2664	1	Input Shaft Kit
5:2	1-603992	1	O-Ring-37 Flare #8	20:2	94-6922	1	Bearing-Thrust
6	103-1799	2	Elbow-90 DEG	20:3	103-2666	1	Cylinder Block Kit
6:1	1-603921	1	O-Ring-Sae #6	20:4	105-6184	1	Seal Overhaul Kit
7	103-1802	2	Fitting-HYD, 90 DEG	21	321-15	2	Screw-HH
7:1	1-603921	1	O-Ring-Sae #6	22	103-2959	1	Hose-Charge
8	116-0942	1	LH HYD Pump ASM	23	103-1807	1	Fitting-Barbed, 45 DEG
8:1	103-2664	1	Input Shaft Kit	23:1	1-603921	1	O-Ring-Sae #6
8:2	94-6922	1	Bearing-Thrust	24	3256-22	2	Washer-1/4 Sae
8:3	103-2666	1	Cylinder Block Kit	25	103-1988	3	Clamp-Hose 11/16
8:4	105-6184	1	Seal Overhaul Kit	26	103-1716	3	Clamp-Hose 17/32
9	32128-43	4	Nut-Whizlock 3/8-16	27	103-1801	1	Adapter-Straight
11	323-7	4	Screw-HH 3/8-16 X 1 1/4	27:1	1-603921	1	O-Ring-Sae #6
12	1-613034	2	Hose-Pressure, High	28	103-7615	1	Asm, Cap W/Gasket
13	1-323241	2	Hose-Pressure, High	29	103-1949	1	Gasket-Cap
14	116-2123	1	Charge Hose ASM	30	103-1947	1	HYD Reservoir ASM
15	116-0918	1	Case Drain Hose ASM				

● Use only for operation below 32°F (0°C).

**Notes:**

## MAXIMIZE THE PERFORMANCE OF YOUR EXMARK.

### **4-CYCLE PREMIUM ENGINE OIL**

Part No. 116-3373

Both SAE 30 and SAE 10W-30 in one bottle.

Contains increased levels of zinc and phosphorus for better lubricity.

No Viscosity Index Improvers that tend to shear down in high heat.

Synthetic formulation.

Gas & Diesel compatible.

Anti-corrosion additives.

API 'SL' and JASO rated with wet clutch compatibility for other machines.

### **PREMIUM HYDRO OIL**

Part No. 109-9828

Commercial quality for tough, high-heat conditions.

Designed specifically for zero-turn mower hydraulic systems.

Superior shear resistance under heavy loads.

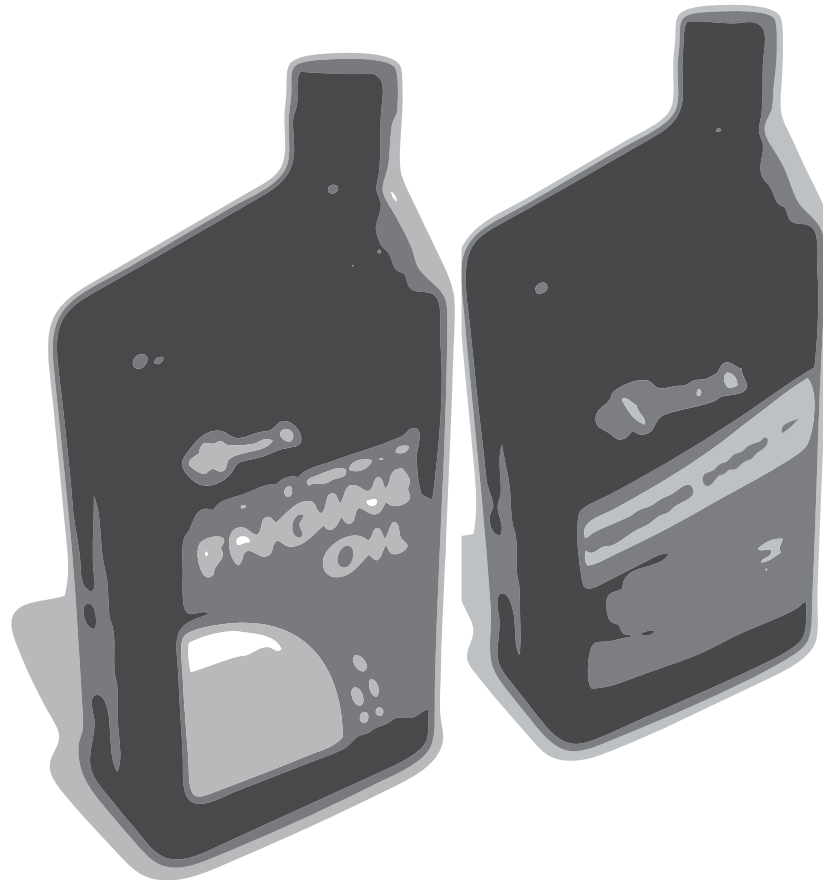

Available from your local Exmark dealer. Find your closest dealer at [exmark.com](http://exmark.com)

## EXMARK ACCESSORIES AND OPTIONS\*

### MID-MOUNT RIDING ACCESSORIES AND OPTIONS

CUSTOM RIDE SEAT SUSPENSION SYSTEM	OPERATOR CONTROLLED DISCHARGE
FULL SUSPENSION SEAT	SUN SHADE
DECK LIFT ASSIST KIT	TRASH CONTAINER
HITCH KIT	TURF STRIPER
LIGHT KIT	ULTRA VAC COLLECTION SYSTEM
12V POWER PORT	ULTRA VAC QUICK DISPOSAL SYSTEM
MICRO-MULCH SYSTEM	

### OUT-FRONT RIDING ACCESSORIES AND OPTIONS

CUSTOM RIDE SEAT SUSPENSION SYSTEM	SNOW BLADE
DUAL-TAIL WHEEL	SNOWBLOWER
FLOOR PAN EXTENDER	SUN SHADE
HITCH KIT	TRASH CONTAINER
LIGHT KIT	ULTRA VAC COLLECTION SYSTEM
MICRO-MULCH SYSTEM	ULTRA VAC QUICK DISPOSAL SYSTEM
ROLL OVER PROTECTION SYSTEM (ROPS)	WEATHER CAB

### WALK-BEHIND ACCESSORIES AND OPTIONS

GRASS CATCHER	TURF STRIPER
MICRO-MULCH SYSTEM	STANDON

\*Some accessories and options not available for some models.

Place Model No. and Serial No.  
Label Here (Included in the Literature  
Pack) or Fill in Below

Model No. \_\_\_\_\_

Serial No. \_\_\_\_\_

Date Purchased \_\_\_\_\_

Engine Model No. and Spec. No. \_\_\_\_\_

Engine Serial No. (E/No) \_\_\_\_\_

© 2012 Exmark Mfg. Co., Inc.  
Industrial Park Box 808  
Beatrice, NE 68310  
All Rights Reserved

Part No. 4500-960 Rev. A  
(402) 223-6300  
Fax (402) 223-5489  
Printed in the USA.

