

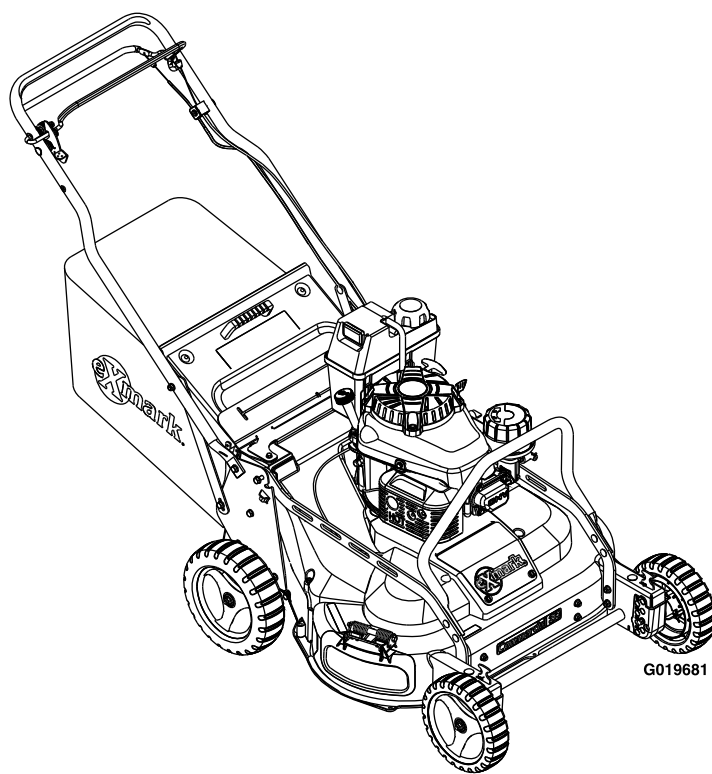

# COMMERCIAL 30

Model No. ECKA30—Serial No. 31300000 and Up

Picture below may not reflect actual product.



G019681

# Parts Manual

Part No. 4500-916 Rev. A

# Ordering Replacement Parts

To order replacement parts, please supply the part number, the quantity, and the description of each part desired.

## Understanding Reference Numbers

Each identified part in an illustration has a reference number. The reference number for a part also appears in the parts list, along with other information about the part.

This catalog uses two special reference number formats, one to indicate parts in a service assembly and another to indicate the quantity of a given part in an illustration.

## Service Assembly Reference Numbers

Parts in service assemblies have reference numbers in the form a:b. The a represents the reference number of the entire service assembly and the b represents a sequential number unique to each part within the service assembly.

For example, a wheel assembly might be identified by reference number 6, the tire by 6:1, the valve by 6:2, and the wheel by 6:3. When you order the assembly identified by reference number 6, you receive all parts identified by reference numbers 6:1, 6:2, and 6:3. However, you may also order any part individually. Reference numbers of this type appear in illustration and in parts lists.

## Reference Numbers Indicating Quantity

In an illustration, if a reference number indicates more than one part, the reference number has the form nX y. The n represents the quantity of the part, the X is the multiplication symbol, and the y represents the reference number.

For example, in an illustration, the reference number 2X 37 means that two of the parts identified by reference number 37 are indicated.

# List of Abbreviations

<b>AR:</b> as required	<b>HJ:</b> hex jam	<b>PRH:</b> phillips round head
<b>ASM:</b> assembly	<b>HLH:</b> hex lag head	<b>PTH:</b> phillips truss head
<b>BBC:</b> blade brake control	<b>HOC:</b> height-of-cut	<b>PTO:</b> power-take-off
<b>BHTF:</b> button head thread forming	<b>HSBH:</b> hex socket button head	<b>RH:</b> right hand
<b>CARR:</b> carriage	<b>HSFH:</b> hex socket flat head	<b>ROPS:</b> roll-over protection system
<b>CCW:</b> counter clockwise	<b>HSH:</b> hex socket head	<b>RRB:</b> rear roller brush
<b>CW:</b> clockwise	<b>HWH:</b> hex washer head	<b>SFH:</b> slotted fillister head
<b>DEG:</b> degrees	<b>HWHTF:</b> hex washer head thread forming	<b>SHH:</b> slotted hex head
<b>DPA:</b> Dual Point Adjustment	<b>HYD:</b> hydraulic	<b>SHWH:</b> slotted hex washer head
<b>ECM:</b> electronic control module	<b>LH:</b> left hand	<b>SPH:</b> slotted pan head
<b>EXT:</b> external	<b>LP:</b> Liquefied Petroleum Gas	<b>SQH:</b> square head
<b>FH:</b> flat head	<b>LPG:</b> Liquefied Petroleum Gas	<b>SRH:</b> slotted round head
<b>GA:</b> gauge	<b>NI:</b> nylon insert	<b>STD:</b> standard
<b>HD:</b> heavy-duty	<b>NPTF:</b> national pipe thread fine	<b>TAP:</b> self tapping
<b>HF:</b> hex flange	<b>PFH:</b> phillips flat head	<b>TTH:</b> torx truss head
<b>HH:</b> hex head	<b>PPH:</b> phillips pan head	
<b>HHF:</b> hex head flange	<b>PPHTF:</b> phillips pan head thread forming	
<b>HHFTF:</b> hex head flange thread forming		

# Touch Up Paint

Exmark black touch up spray paint – gloss black.

Exmark red touch up paint (spray paint – P/N 1-850337 - .6 oz liquid bottle – P/N 103-9140).



If your Exmark dealer does not have the Exmark part in stock, Exmark will get the parts to the dealer the next business day or the part will be FREE Guaranteed!! (Some restrictions apply. See your participating Exmark Dealer for details.)

## Contents

Deck, Frame, and Chute Assembly .....	4
Deck W/Decals .....	5
Spindle and Blade Assembly .....	6
Side Discharge Chute Assembly .....	7
Engine and Fuel Tank Assembly .....	8
Bag Assembly .....	9
Front Bumper and Wheel Assembly .....	10
Deck and Wheel Assembly .....	11
Handle Assembly .....	12

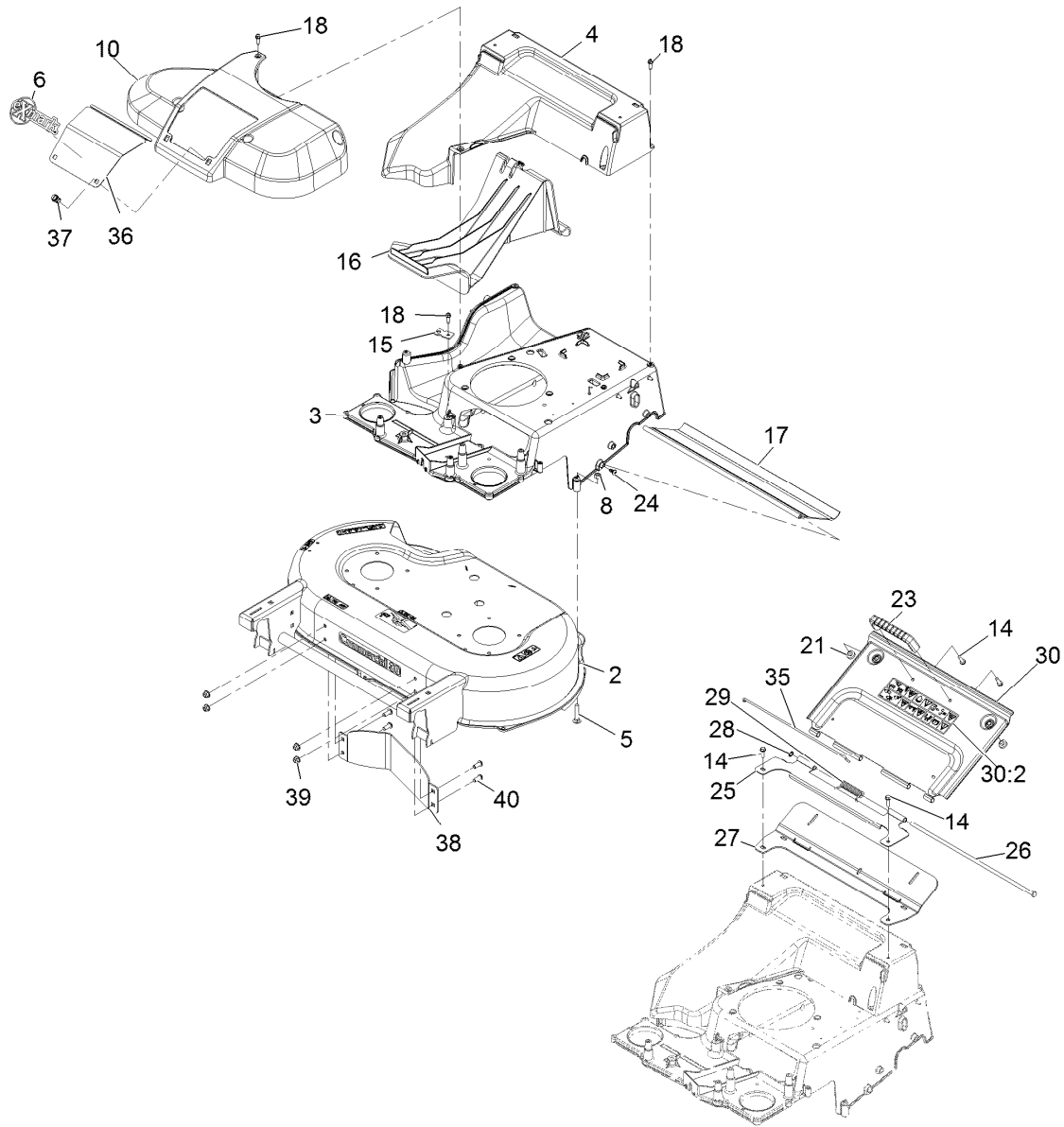

## Deck, Frame, and Chute Assembly

<i>Ref.</i>	<i>Part Number</i>	<i>Qty.</i>	<i>Description</i>	<i>Ref.</i>	<i>Part Number</i>	<i>Qty.</i>	<i>Description</i>
2	116-8354	1	Deck ASM	24	117-1092	2	Screw-PTH
3	121-5807-01	1	Frame	25	116-6351-03	1	Bracket-Hinge
4	120-3336	1	Chute	26	116-6933	1	Pin-Hinge
5	3230-5	2	Bolt-Carriage 5/16-18 X 1 3/4	27	116-6229	1	Seal-Door
6	103-2883	1	Decal, Exmark Logo	28	32151-72	1	Ring-Retaining
8	3296-29	2	Nut-Nyloc 5/16-18	29	116-7573	1	Spring-Torsion, Cover
10	121-5810	1	Cover-Belt	30	116-8355	1	Rear Door ASM
14	46-8091	4	Screw-HWH 1/4-10 X .82 Plastite	30:2	116-7583	1	Decal-Warning
15	107-7497	1	Bracket-Cable, Traction	35	116-6966	1	Clip-Seal
16	120-5225	1	Plug-Mulch	36	121-5793-03	1	Door-Access
17	121-5841	1	Shield-Trailing	37	121-5840	2	Fastener-Quarter Turn
18	49-2040	9	Screw-HWH 1/4-20 X 3/4 Tf	38	116-5588-01	1	Baffle-Flow Control
21	1-513658	2	Bumper	39	104-8300	4	Nut-Nyloc 5/16-18 Flg
23	65-5100	1	Handle-Door	40	3274-55	4	Screw-Button Head 5/16-18 X 3/4

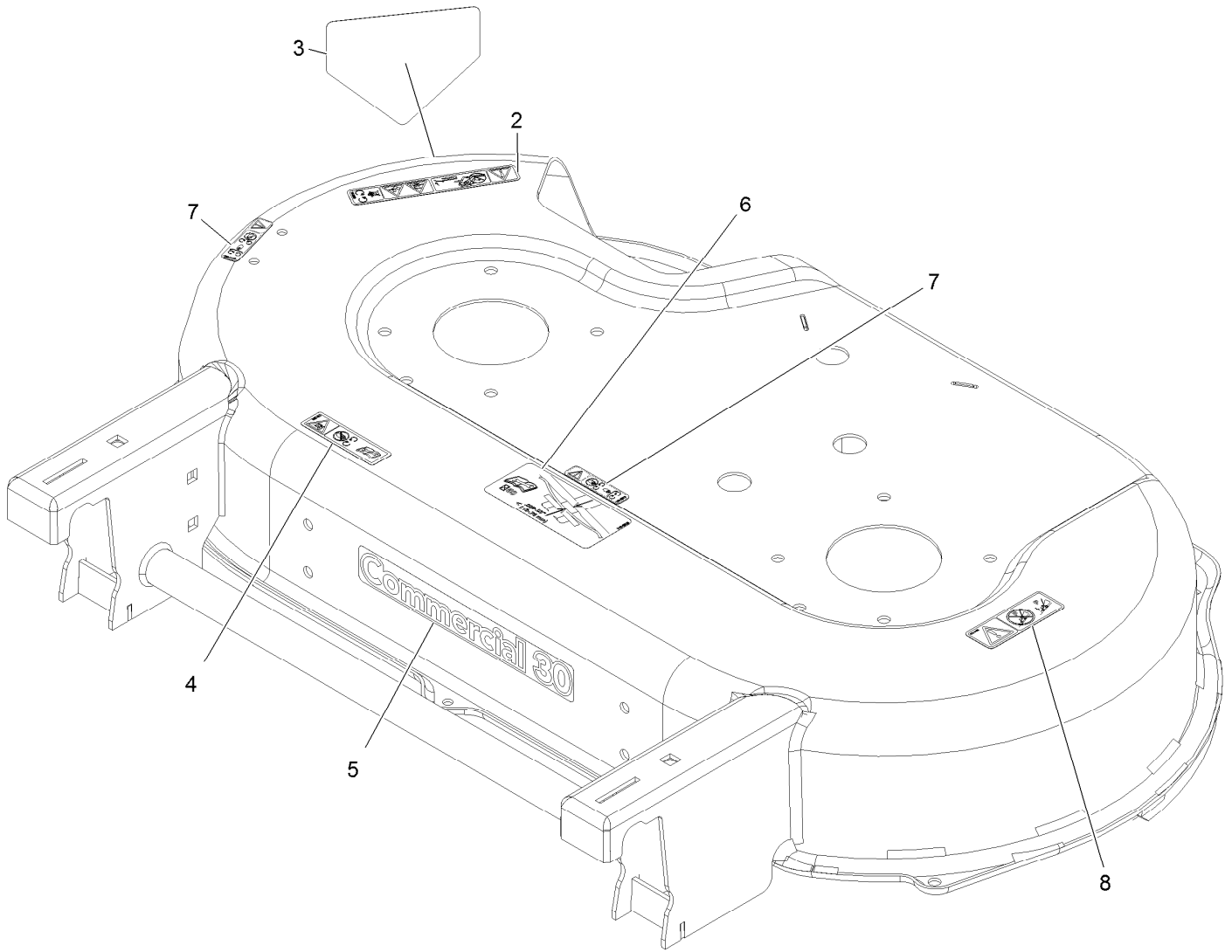

## Deck W/Decals

<i>Ref.</i>	<i>Part Number</i>	<i>Qty.</i>	<i>Description</i>
2	93-7009	1	Decal-Danger, Deflector
3	94-8072	1	Decal-Danger
4	116-7581	1	Decal-Warning
5	116-8527	1	Decal-Commercial 30
6	116-8528	1	Decal-Belt Tensioner
7	120-9570	2	Decal-Warning
8	121-1449	1	Decal-Warning, Block

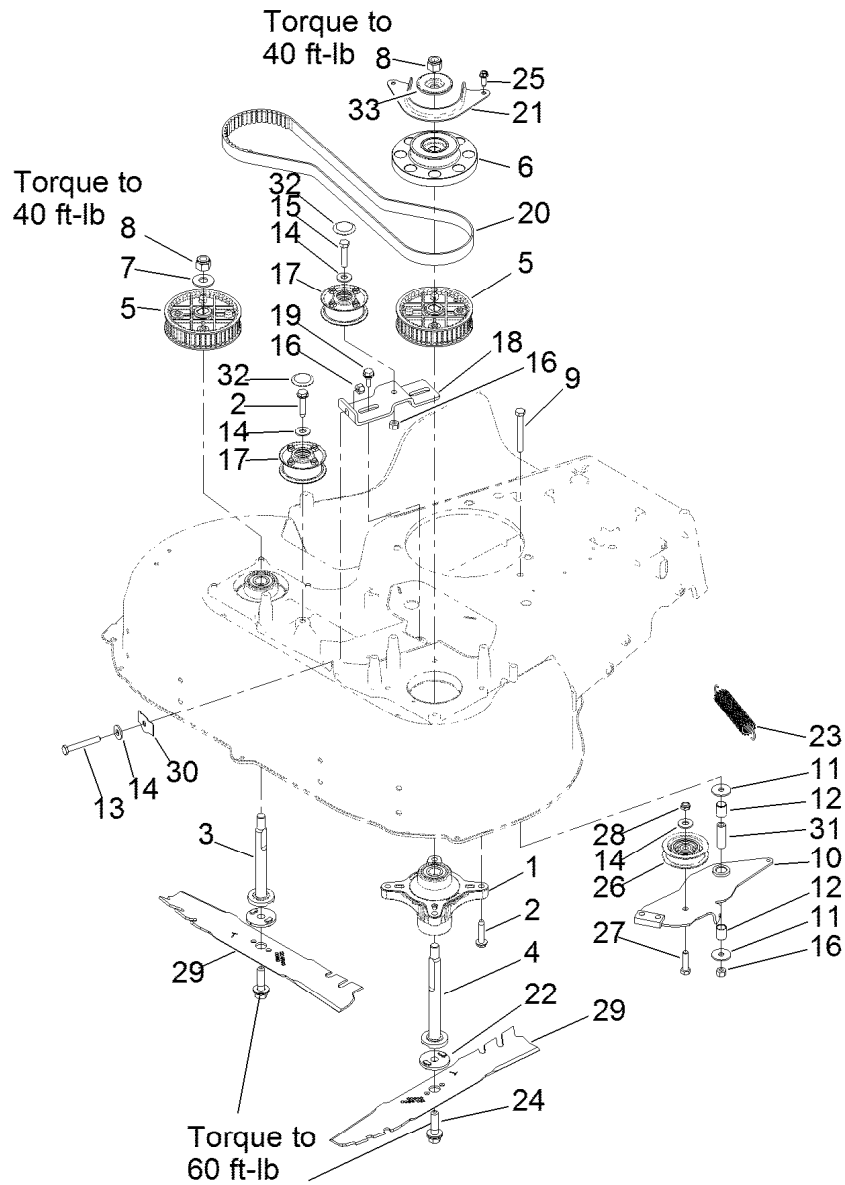

## Spindle and Blade Assembly

Ref.	Part Number	Qty.	Description
1	121-9107	2	Spindle ASM
2	32144-57	9	Screw
3	120-5234	1	Shaft-Spindle
4	120-5235	1	Shaft-Spindle
5	121-9100	2	Sprocket ASM
6	120-3334	1	Pulley-Brake, Spindle
7	109-9505	1	Washer, Spring Disc 1/2
8	3296-19	2	Nut-Nyloc 1/2-20
9	322-13	1	Screw-HH 5/16-18 X 2 3/4
10	121-5796	1	Brake Arm ASM
11	5-4460	2	Washer-Pivot
12	108-9782	2	Bushing-Sleeve
13	9114524	1	Bolt-TAP, HH
14	3256-3	4	Washer-5/16 Std
15	322-7	1	Screw-HH 5/16-18 X 1 1/2
16	3296-29	3	Nut-Nyloc 5/16-18
17	125-2532	2	Pulley ASM

Ref.	Part Number	Qty.	Description
18	120-3348	1	Bracket-Idler
19	120-7024	2	Screw-Shoulder, HHF
20	120-3335	1	Belt-Synchronous
21	120-5245-03	1	Guide-Belt, Spindle
22	120-5236	2	Adapter-Blade
23	121-5808	1	Spring-Extension, Brake
24	125-2466	2	Bolt-Blade, Sems
25	49-2040	2	Screw-HWH 1/4-20 X 3/4 Tf
26	120-7082	1	Pulley-Idler
27	322-6	1	Screw-HH 5/16-18 X 1 1/4
28	3296-47	1	Nut-Nyloc 5/16-18 Thin
29	116-6358-03	2	Blade-Rotary
30	121-2336	1	Spring-Flat
31	121-5812	1	Spacer-Brake
32	125-2533	2	Plug-Cap
33	125-2544	1	Washer-Cup

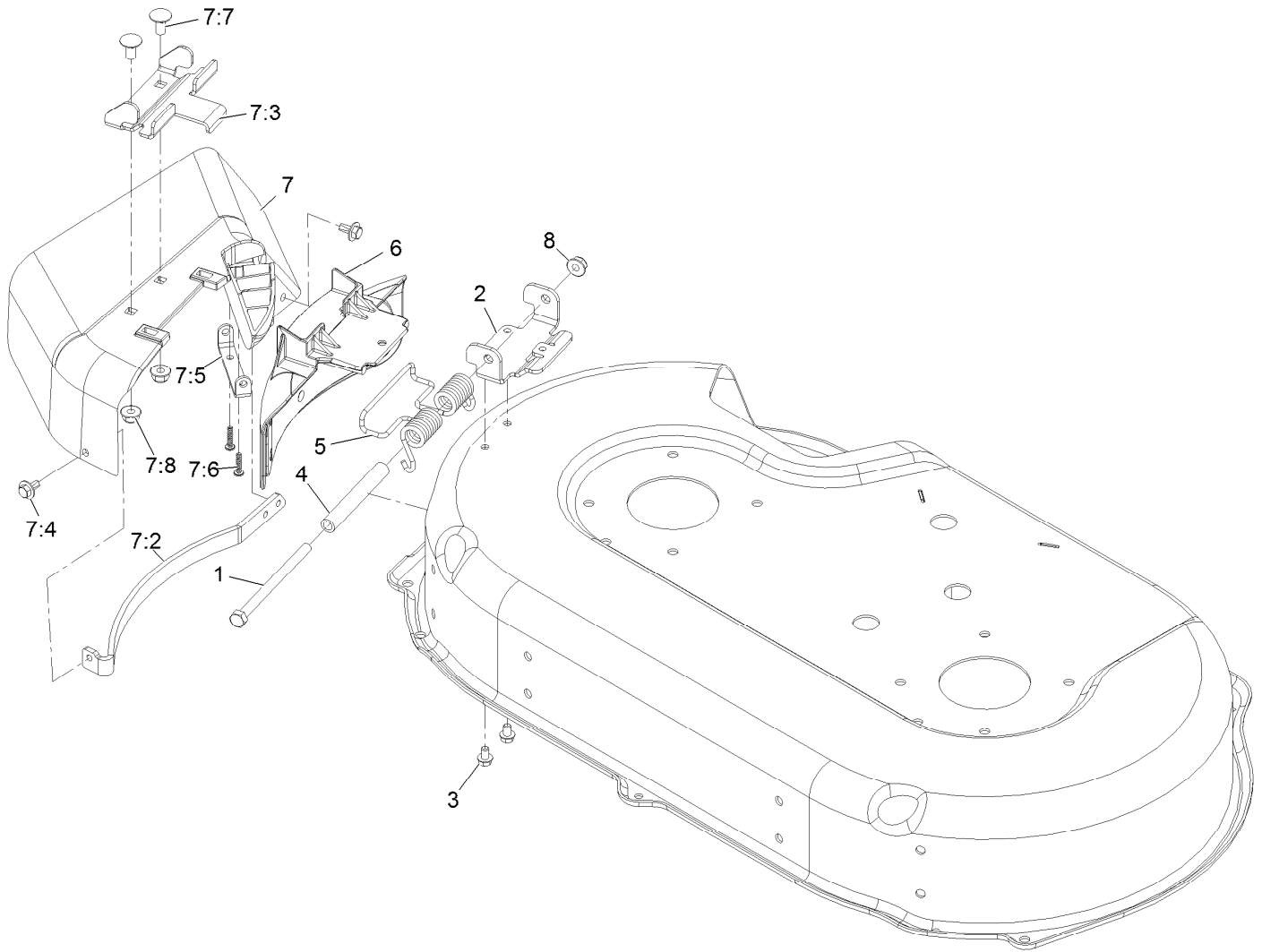

## Side Discharge Chute Assembly

Ref.	Part Number	Qty.	Description
1	322-38	1	Screw-HH 5/16-18 X 4 1/2
2	121-9195	1	Hinge
3	99-8445	2	Screw-HWH 1/4-20 X 3/8 Taptite
4	125-2478	1	Spacer
5	121-9193	1	Spring-Torsion
6	125-5093-01	1	Cover-Discharge
7	116-9754	1	Chute-Side Discharge, ASM
7:2	116-9752-03	1	Guard-Chute
7:3	121-9196	1	Bracket-Chute
7:4	46-8560	2	Screw-HHF 1/4-20 X 1/2
7:5	112-6416	1	Bracket-Cover
7:6	94-4496	2	Screw-PPH
7:7	3230-18	2	Bolt-Carriage 5/16-18 X 5/8
7:8	104-8300	2	Nut-Nyloc 5/16-18 Flg
8	104-8300	1	Nut-Nyloc 5/16-18 Flg

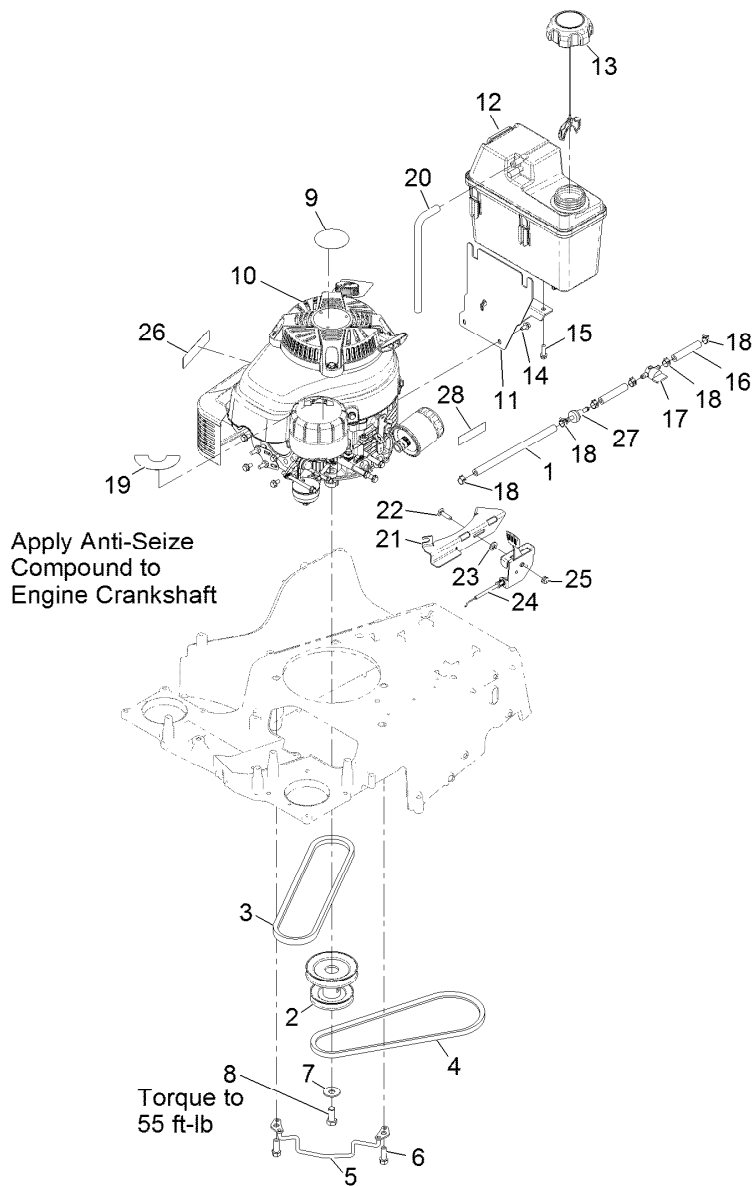

## Engine and Fuel Tank Assembly

Ref.	Part Number	Qty.	Description	Ref.	Part Number	Qty.	Description
1	119-1892	1	Hose-Fuel	15	46-8091	2	Screw-HWH 1/4-10 X .82 Plastite
2	116-7013	1	Pulley-Engine	16	109-0304	2	Hose-Fuel Line 2 1/2"
3	121-5765	1	V-Belt	17	1-603770	1	Valve-Fuel
4	116-7116	1	Belt	18	2412-98	6	Clamp-Hose
5	120-7077	1	Guide-Belt	19	114-3415	1	Decal
6	95-1726	3	Screw-HWH 3/8-16 X 1 Taptite	20	115-0962	1	Hose-Vent, Canister
7	3290-465	1	Washer-Spring Disc	21	116-2220-03	1	Bracket-Mount, Throttle
8	3212-4	1	Screw-HH 7/16-20 X 1	22	3229-30	1	Bolt-Carriage 1/4-20 X 1
9	109-6528	1	Decal, Recoil	23	3256-23	1	Washer-5/16 Sae
10		1	Engine-Kawasaki Fj180V ●■	24	116-2248	1	Throttle
11	115-0954-03	1	Tank Mount ASM	25	104-7201	1	Nut-Nyloc 1/4-20 Flg
12	125-5066	1	Tank ASM	26	117-2718	1	Decal-Arrester, Spark
13	109-6776	1	Cap-Ratchet, Tethered	27	71-9280	1	Filter-Fuel
14	116-8929	3	Screw-HWH	28	116-9313	1	Decal-Warning, Engine

● Not serviced separately

■ Obtain parts from [www.kawpowerpc.com](http://www.kawpowerpc.com)



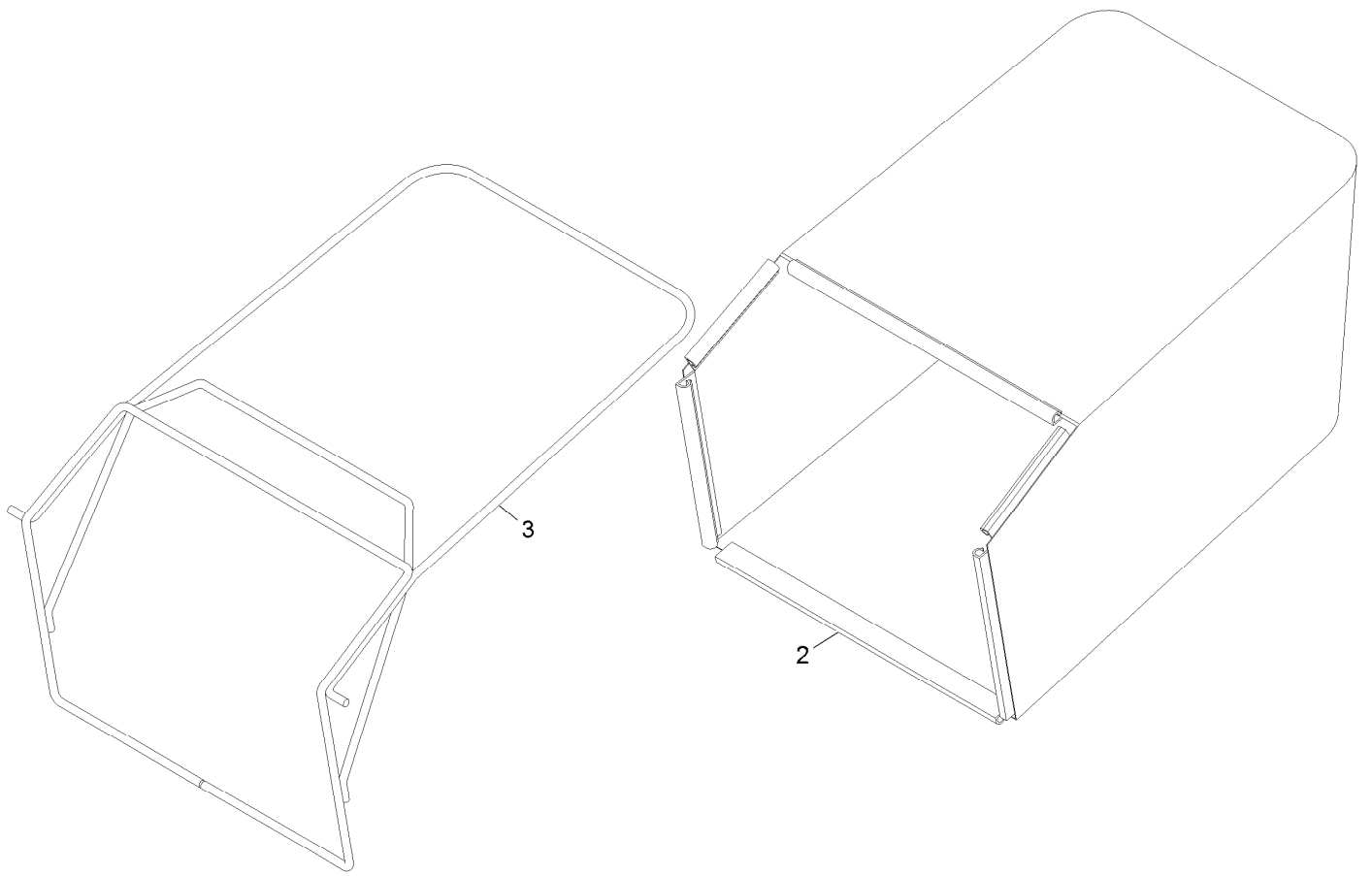

## Bag Assembly

<i>Ref.</i>	<i>Part Number</i>	<i>Qty.</i>	<i>Description</i>
2	116-6350	1	Bag-Grass
3	116-5596-03	1	Frame-Bag

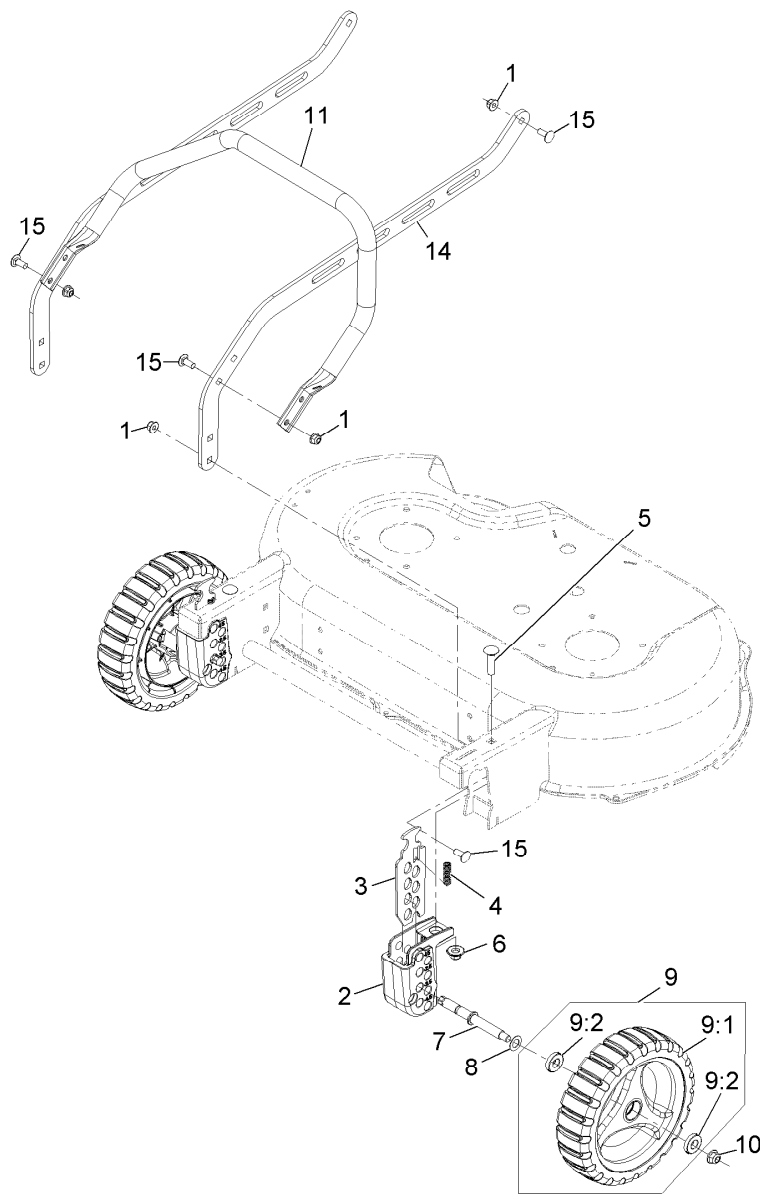

## Front Bumper and Wheel Assembly

Ref.	Part Number	Qty.	Description
1	104-8300	10	Nut-Nyloc 5/16-18 Flg
2	116-6357	2	Block-Front Quadrant
3	109-9292	2	Plate, Front Height
4	109-7258	2	Spring-Compression
5	3231-26	2	Bolt-Carriage 3/8-16 X 1 1/2
6	109-6658	2	Nut-Nyloc 3/8-16 Flg
7	116-0994	2	Axle-Wheel
8	36-4780	2	Washer
9	109-8016	2	Wheel And Tire ASM
9:1	109-8033	1	9-Inch Wheel ASM
9:2	109-8020	2	Bearing-Ball
10	104-8301	2	Nut-Nyloc 3/8-16 Flg
11	116-7675-03	1	Guard-Engine
14	116-7661-03	2	Brace-RH
15	3230-23	10	Bolt-Carriage 5/16-18 X 3/4 Short Neck

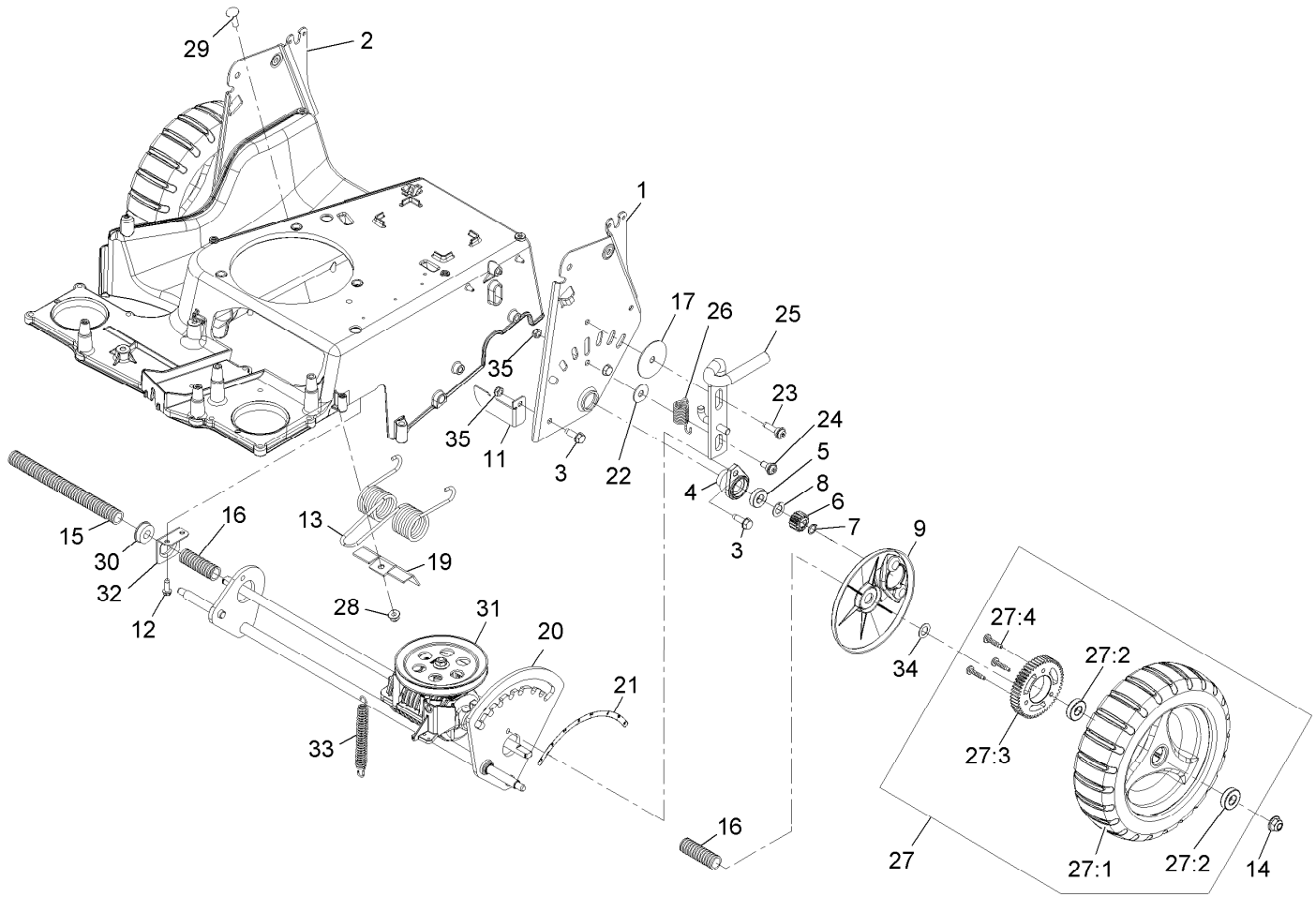

## Deck and Wheel Assembly

Ref.	Part Number	Qty.	Description
1	121-2394-03	1	LH HOC Plate ASM
2	121-2395-03	1	RH HOC Plate ASM
3	701243	7	Screw-HWHTF
4	120-5210	2	Retainer-Bearing
5	109-8020	2	Bearing-Ball
6	110-9417	2	Gear-Pinion, 15T
7	32151-61	2	Ring-Retaining
8	110-7191	2	Washer-Thrust
9	116-6352	2	Cover-Gear
11	121-5821	1	Bracket-Stop
12	49-2040	2	Screw-HWH 1/4-20 X 3/4 Tf
13	121-2368	1	Spring-Torsion
14	104-8301	2	Nut-Nyloc 3/8-16 Flg
15	121-5799	1	Conduit-Convolute
16	121-5800	2	Conduit-Convolute
17	125-2540	1	Washer-Plain
19	121-2397	1	Bracket
20	120-7095	1	Axle-Rear
21	116-7127	1	Decal-HOC, Rear

Ref.	Part Number	Qty.	Description
22	52-2860	1	Washer
23	119-2267	1	Screw-Shoulder, BHTF
24	120-9471	1	Bolt-Shoulder
25	120-7090	1	Lock-Height, Adjust
26	120-9452	1	Spring-Extension
27	116-5291	2	10-Inch Rear Wheel
27:1	116-5292	1	ASM-Wheel 10"
27:2	109-8020	2	Bearing-Ball
27:3	109-7264	1	Gear
27:4	27-6260	3	Screw-Drive
28	104-8300	1	Nut-Nyloc 5/16-18 Flg
29	3230-2	1	Bolt-Carriage 5/16-18 X 1
30	104-8699	1	Bearing-Ball
31	116-6999	1	Transmission
32	120-7008	1	Mount-Bearing
33	120-7027	1	Spring-Extension
34	36-4780	2	Washer
35	3296-47	2	Nut-Nyloc 5/16-18 Thin

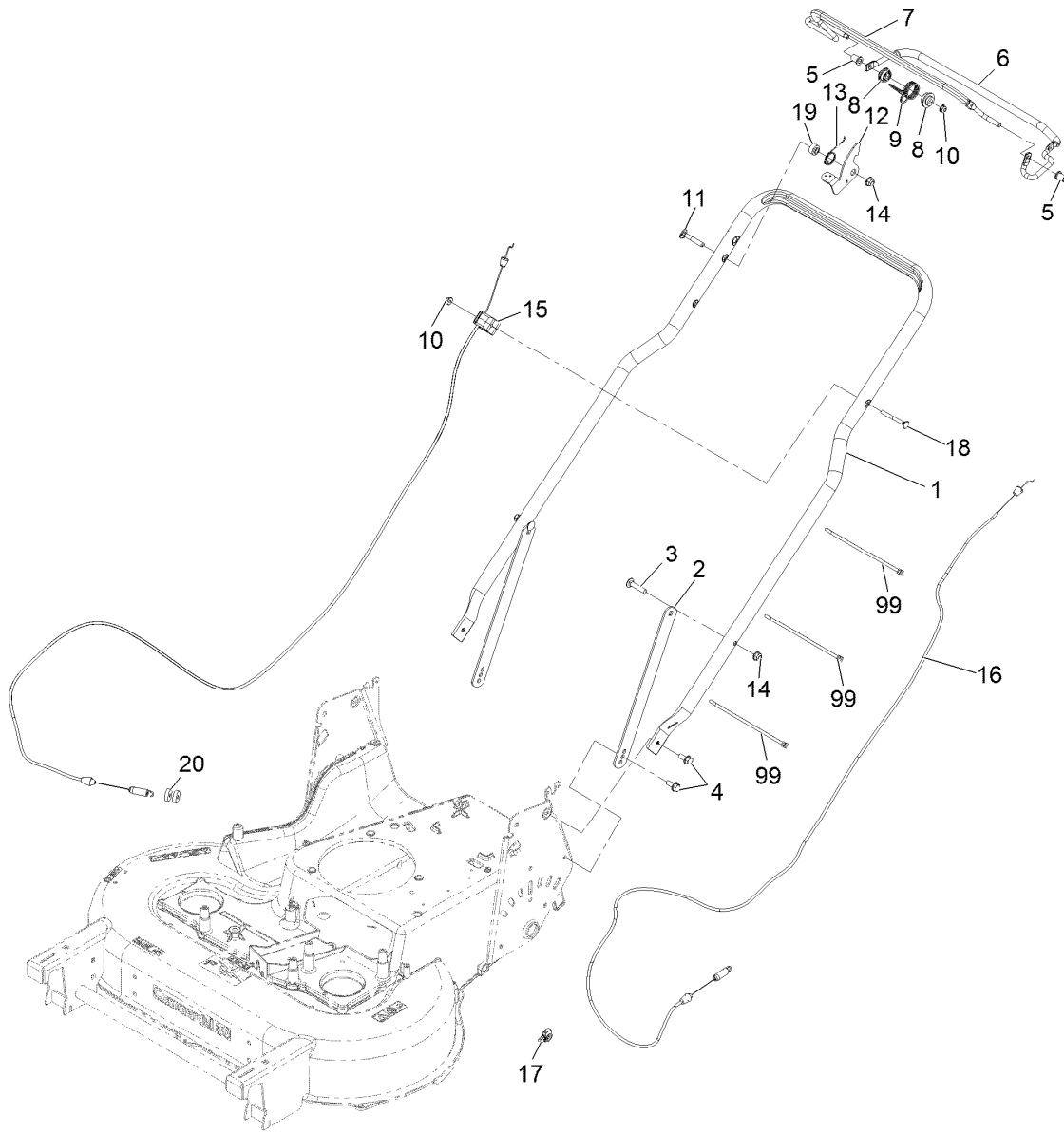

## Handle Assembly

<i>Ref.</i>	<i>Part Number</i>	<i>Qty.</i>	<i>Description</i>	<i>Ref.</i>	<i>Part Number</i>	<i>Qty.</i>	<i>Description</i>
1	120-7086-03	1	Handle	11	112-8876	1	Bolt-Carriage 5/16-18 X 2
2	116-8208-03	2	Support-Handle	12	116-2998	1	Lever-BBC
3	3230-4	2	Bolt-Carriage 5/16-18 X 1 1/2	13	109-9318	1	Spring-Lever, BBC
4	116-7230	4	Screw-HHF	14	104-8300	3	Nut-Nyloc 5/16-18 Flg
5	116-1478	2	Bushing-Handlebar	15	121-2310	1	Cable-Brake, BBC
6	116-7907	1	Bail-Drive Coated	16	116-5003	1	Cable-Drive, Crosscut
7	109-8442	1	Bail	17	125-2545	1	Clip-Conduit
8	109-8457	2	Bushing-Spring, Pivot	18	92-2270	1	Screw-Handle
9	116-5594	1	Spring-Return, BBC	19	116-2690	1	Bushing-Stepped
10	104-7201	2	Nut-Nyloc 1/4-20 Flg	20	1-323417	2	Washer-Belt Shield
				99	614249	3	Tie-Cable

**Notes:**

**Notes:**

**Notes:**

## EXMARK ACCESSORIES AND OPTIONS\*

### MID-MOUNT RIDING ACCESSORIES AND OPTIONS

CUSTOM RIDE SEAT SUSPENSION SYSTEM	OPERATOR CONTROLLED DISCHARGE
FULL SUSPENSION SEAT	SUN SHADE
DECK LIFT ASSIST KIT	TRASH CONTAINER
HITCH KIT	TURF STRIPER
LIGHT KIT	ULTRA VAC COLLECTION SYSTEM
12V POWER PORT	ULTRA VAC QUICK DISPOSAL SYSTEM
MICRO-MULCH SYSTEM	

### OUT-FRONT RIDING ACCESSORIES AND OPTIONS

CUSTOM RIDE SEAT SUSPENSION SYSTEM	SNOW BLADE
DUAL-TAIL WHEEL	SNOWBLOWER
FLOOR PAN EXTENDER	SUN SHADE
HITCH KIT	TRASH CONTAINER
LIGHT KIT	ULTRA VAC COLLECTION SYSTEM
MICRO-MULCH SYSTEM	ULTRA VAC QUICK DISPOSAL SYSTEM
ROLL OVER PROTECTION SYSTEM (ROPS)	WEATHER CAB

### WALK-BEHIND ACCESSORIES AND OPTIONS

GRASS CATCHER	TURF STRIPER
MICRO-MULCH SYSTEM	STANDON

\*Some accessories and options not available for some models.

Place Model No. and Serial No.  
Label Here (Included in the Literature  
Pack) or Fill in Below

Model No. \_\_\_\_\_

Serial No. \_\_\_\_\_

Date Purchased \_\_\_\_\_

Engine Model No. and Spec. No. \_\_\_\_\_

Engine Serial No. (E/No) \_\_\_\_\_

© 2013 Exmark Mfg. Co., Inc.  
Industrial Park Box 808  
Beatrice, NE 68310  
All Rights Reserved

Part No. 4500-916 Rev. A  
(402) 223-6300  
Fax (402) 223-5489  
Printed in the USA.

