

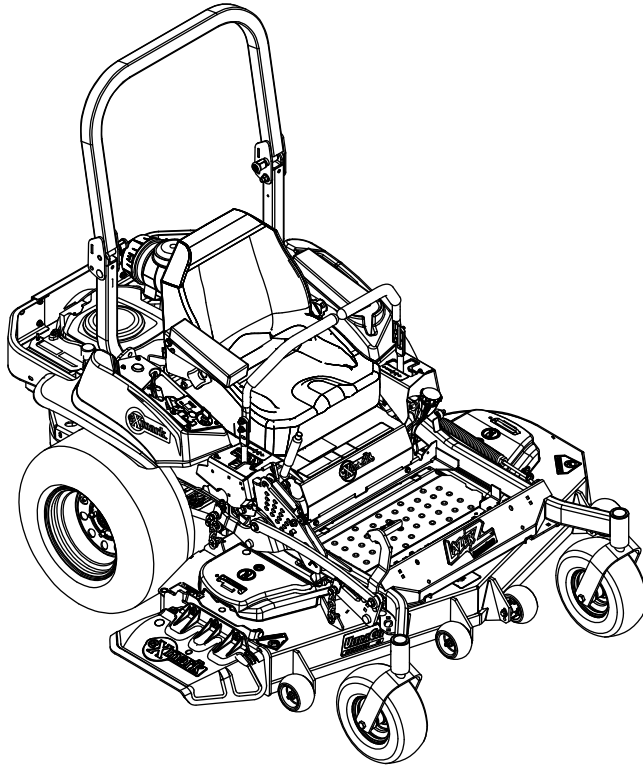

# **LAZER Z<sup>®</sup> S-SERIES**

Model No. LZS24KA524CA—Serial No. 920000 and Up



# **Parts Manual**

Part No. 4500-870 Rev. A

# Ordering Replacement Parts

To order replacement parts, please supply the part number, the quantity, and the description of each part desired.

## Understanding Reference Numbers

Each identified part in an illustration has a reference number. The reference number for a part also appears in the parts list, along with other information about the part.

This catalog uses two special reference number formats, one to indicate parts in a service assembly and another to indicate the quantity of a given part in an illustration.

## Service Assembly Reference Numbers

Parts in service assemblies have reference numbers in the form a:b. The a represents the reference number of the entire service assembly and the b represents a sequential number unique to each part within the service assembly.

For example, a wheel assembly might be identified by reference number 6, the tire by 6:1, the valve by 6:2, and the wheel by 6:3. When you order the assembly identified by reference number 6, you receive all parts identified by reference numbers 6:1, 6:2, and 6:3. However, you may also order any part individually. Reference numbers of this type appear in illustration and in parts lists.

## Reference Numbers Indicating Quantity

In an illustration, if a reference number indicates more than one part, the reference number has the form nX y. The n represents the quantity of the part, the X is the multiplication symbol, and the y represents the reference number.

For example, in an illustration, the reference number 2X 37 means that two of the parts identified by reference number 37 are indicated.

# List of Abbreviations

<b>AR:</b> as required	<b>HOC:</b> height-of-cut	<b>RRB:</b> rear roller brush
<b>ASM:</b> assembly	<b>HSBH:</b> hex socket button head	<b>SFH:</b> slotted fillister head
<b>BBC:</b> blade brake control	<b>HSFH:</b> hex socket flat head	<b>SHH:</b> slotted hex head
<b>BHTF:</b> button head thread forming	<b>HSH:</b> hex socket head	<b>SHWH:</b> slotted hex washer head
<b>CARR:</b> carriage	<b>HWH:</b> hex washer head	<b>SPH:</b> slotted pan head
<b>CCW:</b> counter clockwise	<b>HWTF:</b> hex washer head thread forming	<b>SQH:</b> square head
<b>CW:</b> clockwise	<b>HYD:</b> hydraulic	<b>SRH:</b> slotted round head
<b>DEG:</b> degrees	<b>LH:</b> left hand	<b>STD:</b> standard
<b>DPA:</b> Dual Point Adjustment	<b>LP:</b> Liquid Propane	<b>TAP:</b> self tapping
<b>ECM:</b> electronic control module	<b>NI:</b> nylon insert	<b>TTH:</b> torx truss head
<b>EXT:</b> external	<b>NPTF:</b> national pipe thread fine	
<b>FH:</b> flat head	<b>PFH:</b> phillips flat head	
<b>GA:</b> gauge	<b>PPH:</b> phillips pan head	
<b>HD:</b> heavy-duty	<b>PPHTF:</b> phillips pan head thread forming	
<b>HF:</b> hex flange	<b>PRH:</b> phillips round head	
<b>HH:</b> hex head	<b>PTH:</b> phillips truss head	
<b>HHF:</b> hex head flange	<b>PTO:</b> power-take-off	
<b>HHFTF:</b> hex head flange thread forming	<b>RH:</b> right hand	
<b>HJ:</b> hex jam	<b>ROPS:</b> roll-over protection system	
<b>HLH:</b> hex lag head		

# Touch Up Paint

Exmark black touch up spray paint – gloss black.

Exmark red touch up paint (spray paint – P/N 1-850337 - .6 oz liquid bottle – P/N 103-9140).

**EXMARK PARTS PLUS**

***PARTS***

**OVERNIGHT**

**OR *FREE*\***

If your Exmark dealer does not have the Exmark part in stock, Exmark will get the parts to the dealer the next business day or the part will be FREE Guaranteed!! (Some restrictions apply. See your participating Exmark Dealer for details.)

# Contents

Complete Deck Assembly .....	5
Deck Assembly .....	6
Deck W/Decals Assembly No. 109-9008 .....	7
Deck Idler Assembly No. 116-3755 .....	8
Main Frame Assembly .....	9
Roll-Over Protection System Assembly No. 116-0230 .....	10
Caster Wheel and Fork Assembly .....	11
Deck Lift Assembly .....	12
Height-of-Cut Assembly No. 109-7438 .....	13
Controls Assembly .....	14
Motion Control Assembly .....	15
Rear Wheel and Park Brake Assembly .....	16
Brake Handle Assembly No. 116-1878 .....	17
Seat Assembly .....	18
Seat W/Tracks Assembly No. 116-4474 .....	19
Fuel Tank Mounting Assembly .....	20
Fuel Tank Assembly No. 116-3979 .....	21
Engine Assembly .....	22
Hydraulic Assembly .....	23
LH Hydro Assembly No. 116-1322 .....	24
RH Hydro Assembly No. 116-1323 .....	25
Pump Idler Assembly No. 116-1255 .....	26
Electrical Assembly .....	27

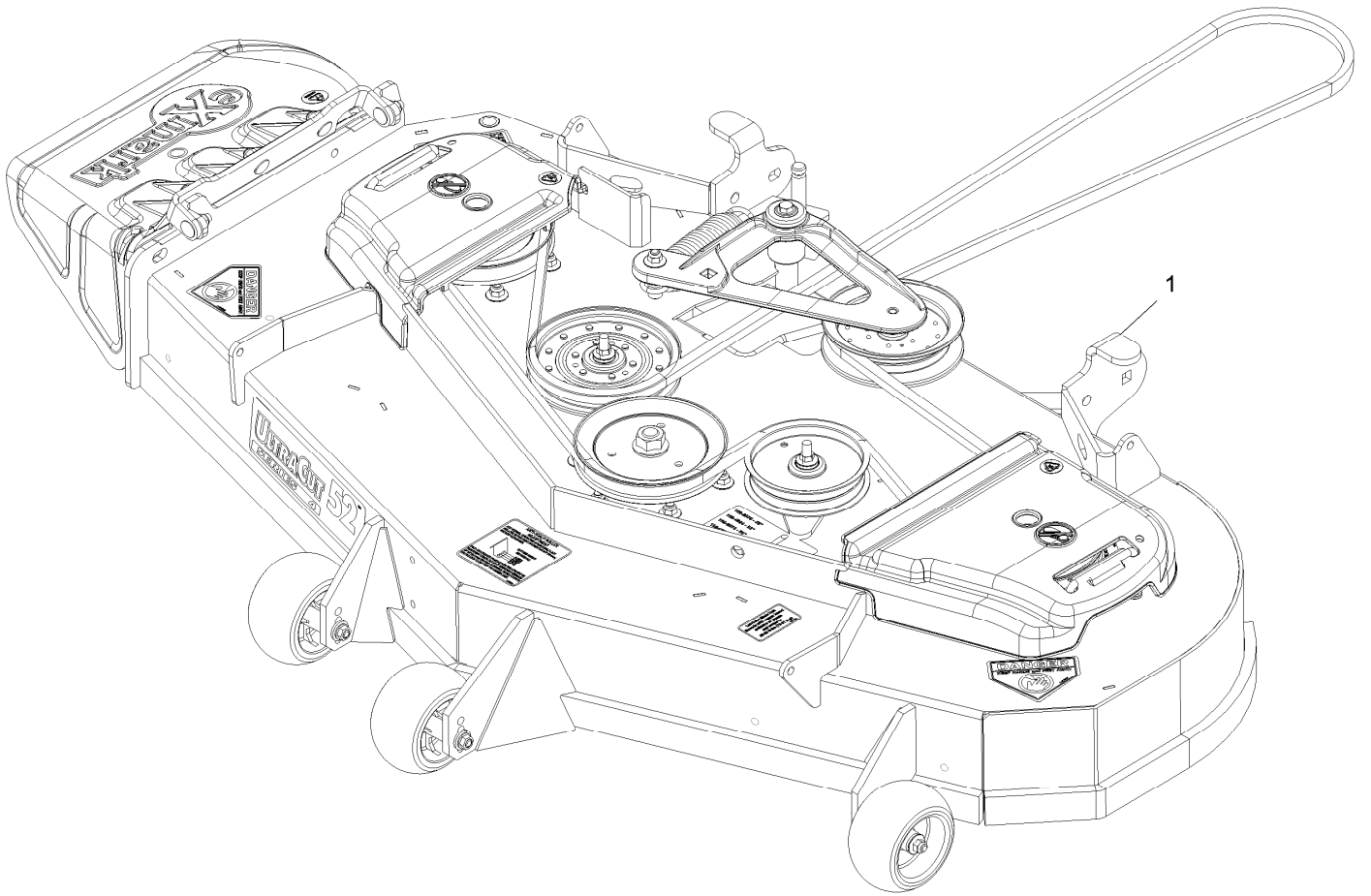

## Complete Deck Assembly

<i>Ref.</i>	<i>Part Number</i>	<i>Qty.</i>	<i>Description</i>
1	116-3598	1	ASM,524 Deck Complete

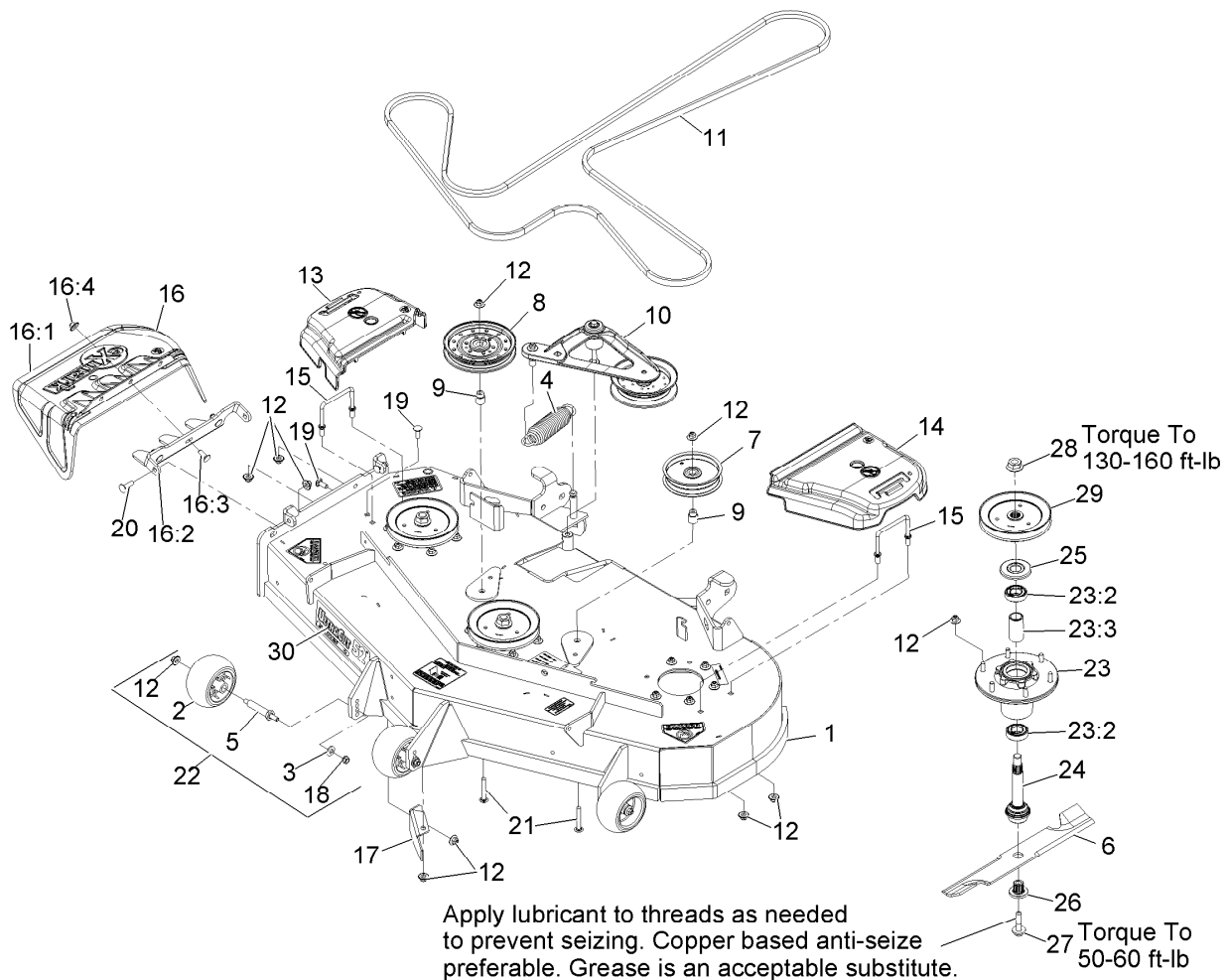

## Deck Assembly

Ref.	Part Number	Qty.	Description	Ref.	Part Number	Qty.	Description
1	109-9149	1	ASM,Deck W/ Decals 52	16:1	109-2738	1	Chute,Discharge
2	1-603299	3	Roller-Scalp, Anti	16:2	109-8675-01	1	Bracket,Discharge Chute
3	98-5975	3	Washer-Spring Disc 3/8	16:3	3231-22	3	Bolt-Carriage 3/8-16 X 1
4	116-0133	1	Extension-Spring	16:4	109-6658	3	Nut-Nyloc 3/8-16 Flg
5	99-2842	3	Spacer	17	109-9915-01	1	Baffle,Discharge 52/60
6	103-6402	3	Blade-Notched	18	3290-357	3	Nut-Whizlock 3/8-16
6	103-6397	3	Blade, Extreme 18.0 (.94 Hole)	19	3231-22	2	Bolt-Carriage 3/8-16 X 1
6	103-6392	3	Blade, Mulch 18.0 (.94 Hole) ●	20	3231-28	2	Bolt-Carriage 3/8-16 X 1 1/4
6	103-6387	3	Blade, Low Lift 18.0 (.94 Hole)	21	3231-44	2	Bolt-Carriage 3/8-16 X 2 1/2
6	103-6382	3	Blade, Solid 18.0 (.94 Hole)	22	103-4051	3	Kit,Anti-Scalp Roller
7	1-613098	1	Pulley-Idler	23	116-3344	3	ASM-Cutter Hsg With Bearings
8	1-633109	1	Idler-Flat	23:2	116-0720	2	Bearing-Ball, 25Mm
9	1-633456	2	Bushing,Idler	23:3	116-3312	1	Spacer-Bearing
10	116-3755	1	Deck Idler ASM	24	116-3341	3	ASM-Spindle And Seal
11	109-4994	1	Belt,V-B X 186.00"	25	116-1286	3	Guard,Bearing Top .989
12	109-6658	31	Nut-Nyloc 3/8-16 Flg	26	103-3037	3	Bushing,Splined
13	109-6935	1	Cover-Belt, RH	27	109-9220	3	Screw-Sems 1/2-20 X 2.19
14	109-6936	1	Cover-Belt, LH	28	104-0753	3	Nut-Hex 3/4-16 Flg Special
15	109-6982	2	Wireform-Cover	29	116-0675	3	Sheave,Blade Drive 6.50
16	109-7188	1	ASM,Discharge Chute	30	116-0034	1	Decal,Ultracut 52 Series 4

● Requires installation of mulch kit for proper mulching. See your Exmark dealer for details.

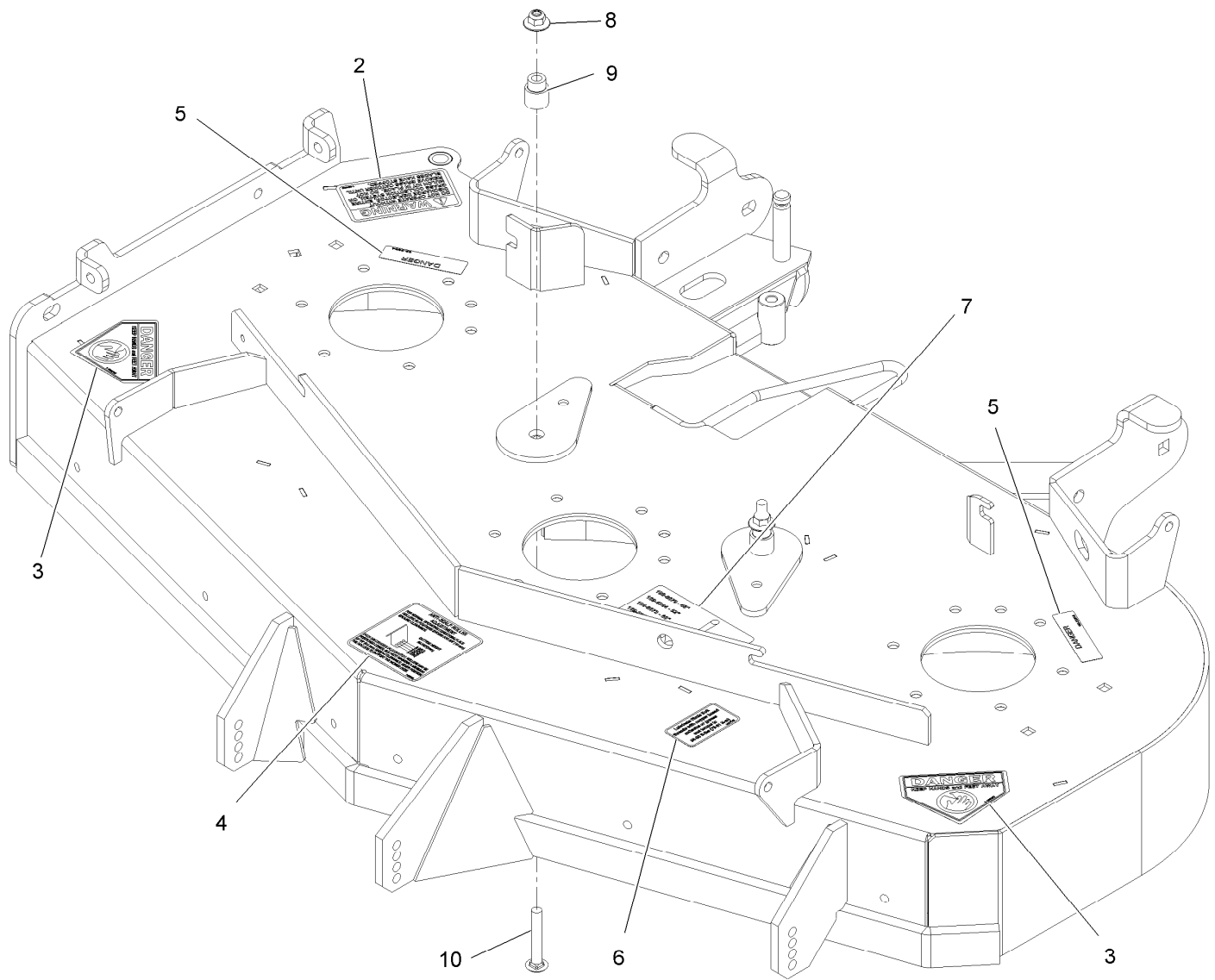

## Deck W/Decals Assembly No. 109-9008

Ref.	Part Number	Qty.	Description
2	1-303508	1	Decal-Warning, Discharge
3	1-403005	2	Decal-Danger
4	1-633922	1	Decal,Antiscalp
5	98-5954	2	Decal-Cover, Missing
6	109-3148	1	Decal,Bolt Torque
7	109-9361	1	Decal,Belt Routing
8	109-6658	2	Nut-Nyloc 3/8-16 Flg
9	1-633456	2	Bushing,Idler
10	3231-44	2	Bolt-Carriage 3/8-16 X 2 1/2

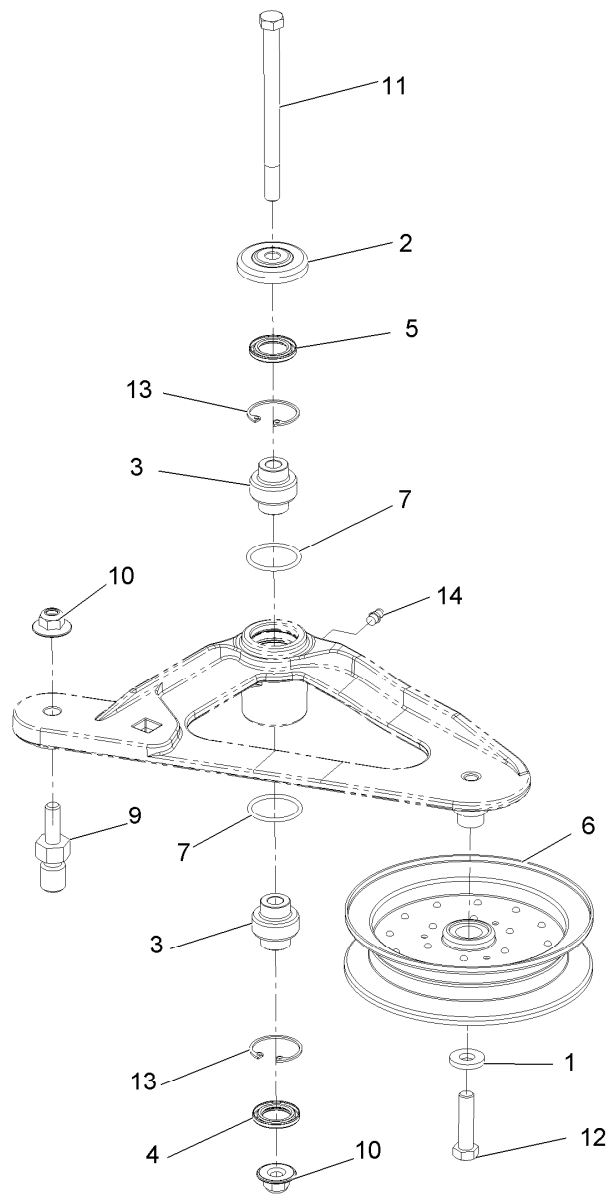

## Deck Idler Assembly No. 116-3755

<i>Ref.</i>	<i>Part Number</i>	<i>Qty.</i>	<i>Description</i>
1	43-0940	1	Spacer-Hub, Blower
2	103-2916	1	Guard-Top
3	103-3504	2	Bearing-Spherical
4	103-3505	1	Seal-Double Lip
5	103-3506	1	Seal-Single Lip
6	103-8743	1	Pulley-Idler, Flanged
7	106-7159	2	O-Ring
9	116-3467	1	Pin, Spring Anchor
10	109-6658	2	Nut-Nyloc 3/8-16 Flg
11	109-7409	1	Screw-Shoulder 3/8-16 X 5
12	323-8	1	Screw-HH 3/8-16 X 1 1/2
13	32120-10	2	Ring-Retaining
14	302-19	1	Zerk-1/4-28 Str



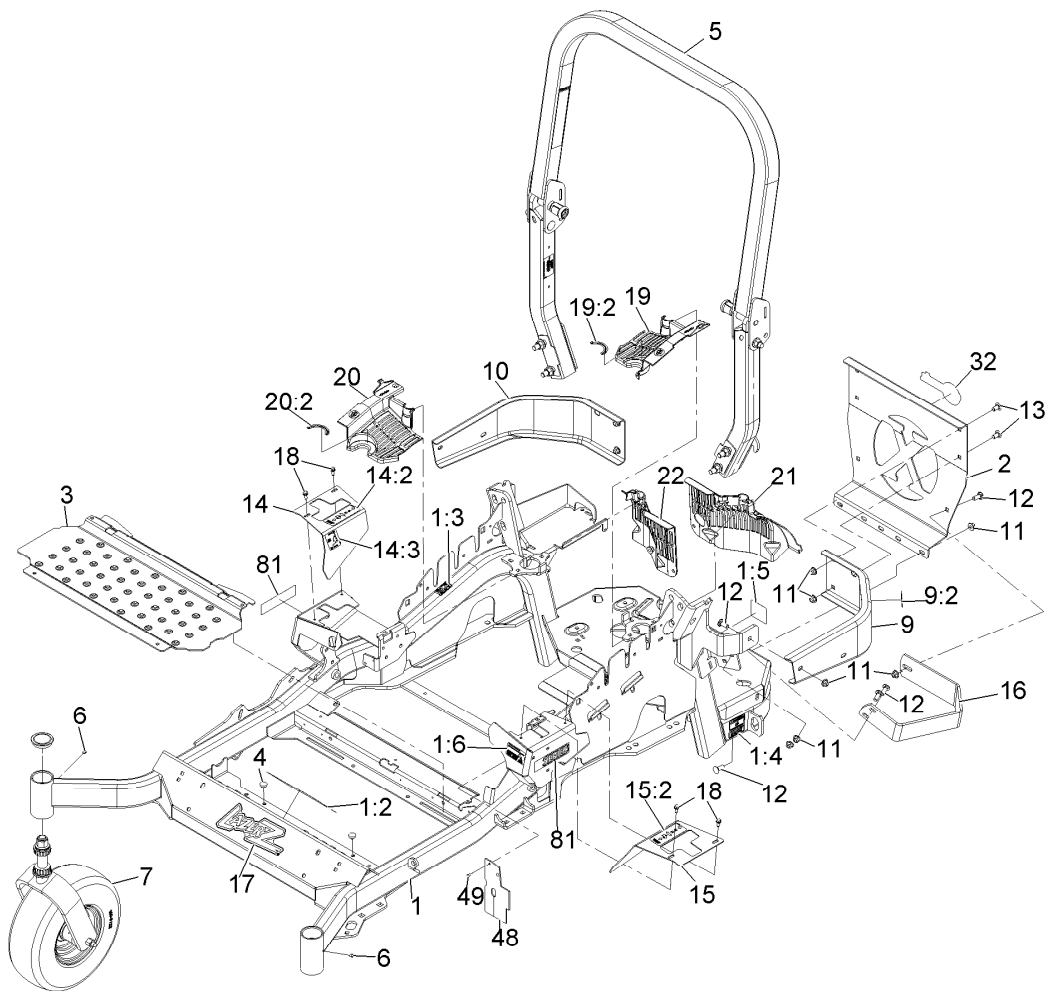

## Main Frame Assembly

Ref.	Part Number	Qty.	Description	Ref.	Part Number	Qty.	Description
1	116-2124	1	Main Frame ASM	14:2	109-7232	1	Decal-Motion Control
1:2	116-3303	1	Decal-Slope	14:3	109-7929	1	Decal-Park Brake
1:3	103-2076	2	Decal-Caution	15	116-0580	1	LH Motion Control Cover ASM
1:4	116-0205	2	Decal-Belt Drive	15:2	109-7232	1	Decal-Motion Control
1:5	116-4858	1	Decal-Spark Arrester	16	116-0043-03	1	Guard-Muffler
1:6	116-1654	1	Decal Fuel Fill	17	103-3113	1	Decal,Lazer Model
2	109-8863-03	1	Plate,Rear Guard	18	32144-10	4	Screw-HWH 1/4-20 X .62
3	116-0024-01	1	Floorpan	19	116-0170	1	LH Hydro Guard ASM
4	1-513658	2	Bumper	19:2	116-0157	1	Decal-Hydro Oil
5	116-0230	1	ASM,ROPS Service Exmark	20	116-0171	1	RH Hydro Guard ASM
6	1-811010	2	Plug	20:2	116-0157	1	Decal-Hydro Oil
7		2	ASM,Front Caster W/Fork ●	21	109-9057	1	Guard-Hydro, Rear LH
9	116-0180	1	LH Bumper ASM	22	109-9058	1	Guard-Hydro, Rear RH
9:2	103-2076	1	Decal-Caution	32	103-2883	1	Decal,Exmark Logo
10	116-0057-03	1	Bumper-RH	48	116-2362	1	Deflector, Air Flow
11	104-8301	11	Nut-Nyloc 3/8-16 Flg	49	1-803035	2	Rivet 3/16 X 1/4
12	3231-22	7	Bolt-Carriage 3/8-16 X 1	81	116-3884	2	Decal-S-Series
13	3231-21	4	Bolt-Carriage 3/8-16 X 3/4				
14	116-0579	1	RH Motion Control Cover ASM				

● Not serviced separately

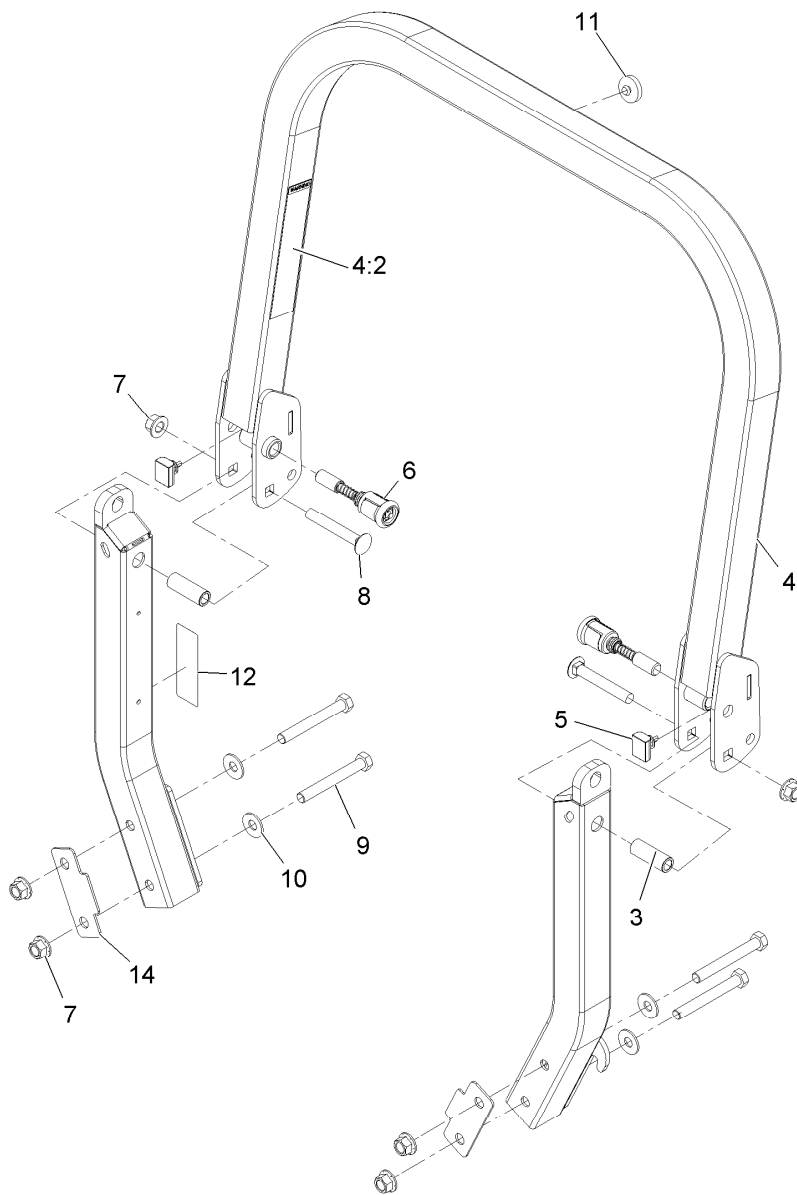

## Roll-Over Protection System Assembly No. 116-0230

<i>Ref.</i>	<i>Part Number</i>	<i>Qty.</i>	<i>Description</i>
3	109-6653	2	Spacer
4	116-0019	1	Upper ROPS ASM
4:2	107-2102	1	Decal-Warning, Folding ROPS
5	109-5337	2	Bumper-ROPS
6	116-0104	2	Spring Pin ASM
7	99-5107	6	Nut-Lock 1/2-13
8	3233-10	2	Bolt-Carriage 1/2-13 X 3 1/2
9	325-17	4	Screw-HH 1/2-13 X 4
10	109-9505	4	Washer-Spring
11	109-9233	1	Bumper-Push-In, Rubber
12	116-0090	1	Decal-Caution
14	116-0960	2	Spacer

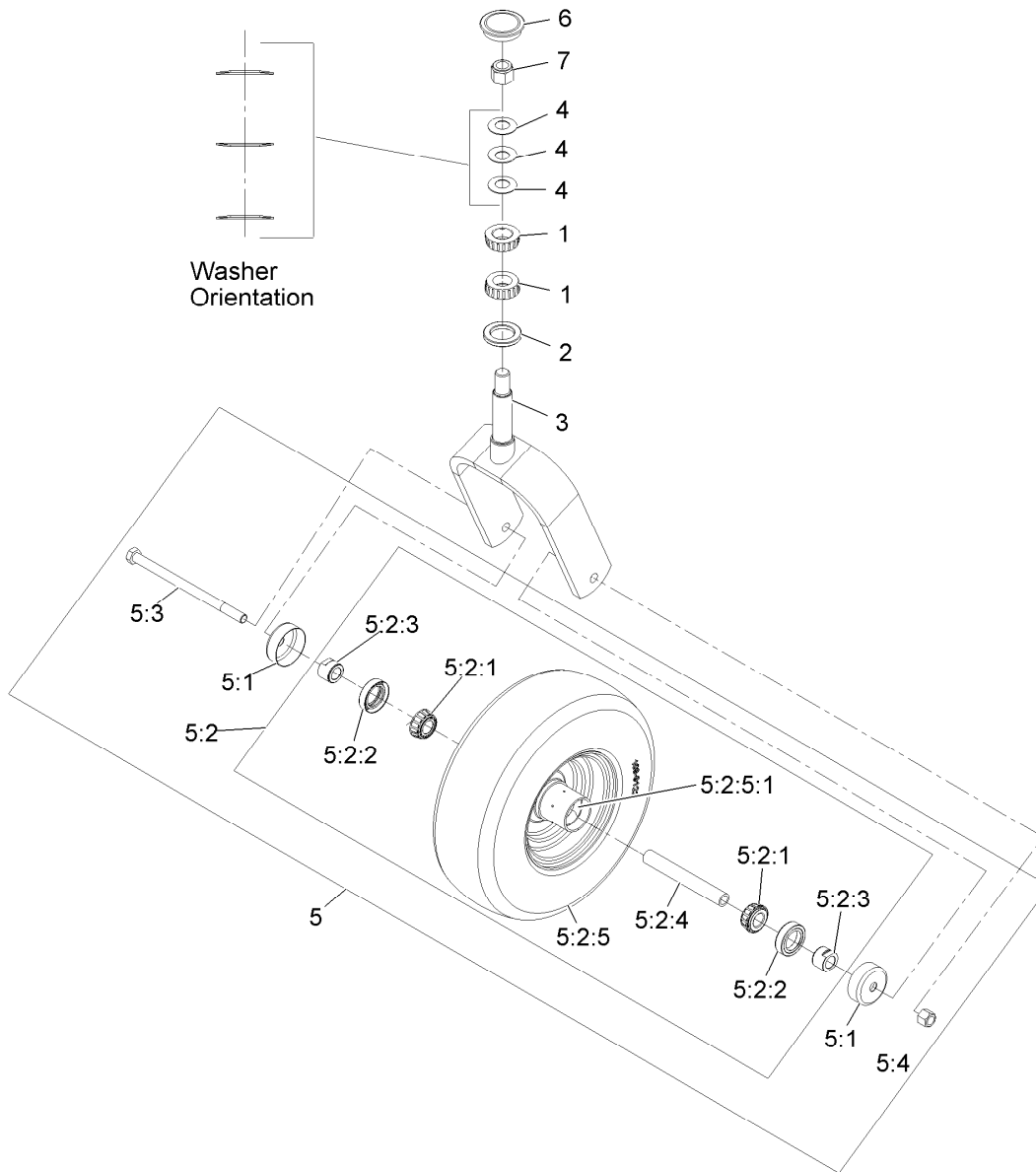

## Caster Wheel and Fork Assembly

Ref.	Part Number	Qty.	Description	Ref.	Part Number	Qty.	Description
1	1-543509	2	Cone-Bearing Tapered Roller	5:2:2	103-0063	2	Seal-Double Lip
2	1-543511	1	Seal-Grease	5:2:3	103-3051	2	Spacer-Nut ■
3	116-1092-01	1	Wld, Caster	5:2:4	103-3155	1	Axle-Caster
4	1-633508	3	Washer-Spring Disc	5:2:5		1	Wheel And Tire ASM ●
5	109-9126	1	Wheel And Tire ASM	5:2:5:1	1-633584	1	Bearing-Cup
5:1	103-2768	2	Guard-Seal	5:3	325-42	1	Screw-HH 1/2-13 X 8
5:2		1	Wheel And Tire ASM ●	5:4	3296-23	1	Nut-Nyloc 1/2-13
5:2:1	1-633585	2	Bearing-Cone Tapered Roller	6	103-4882	1	Cap-Grease
				7	3296-51	1	Nut-Nyloc 3/4-10

● Not serviced separately

■ Use Pro-Lock, Nut Type (P/N 1-840022, .5ml tube) on threads.

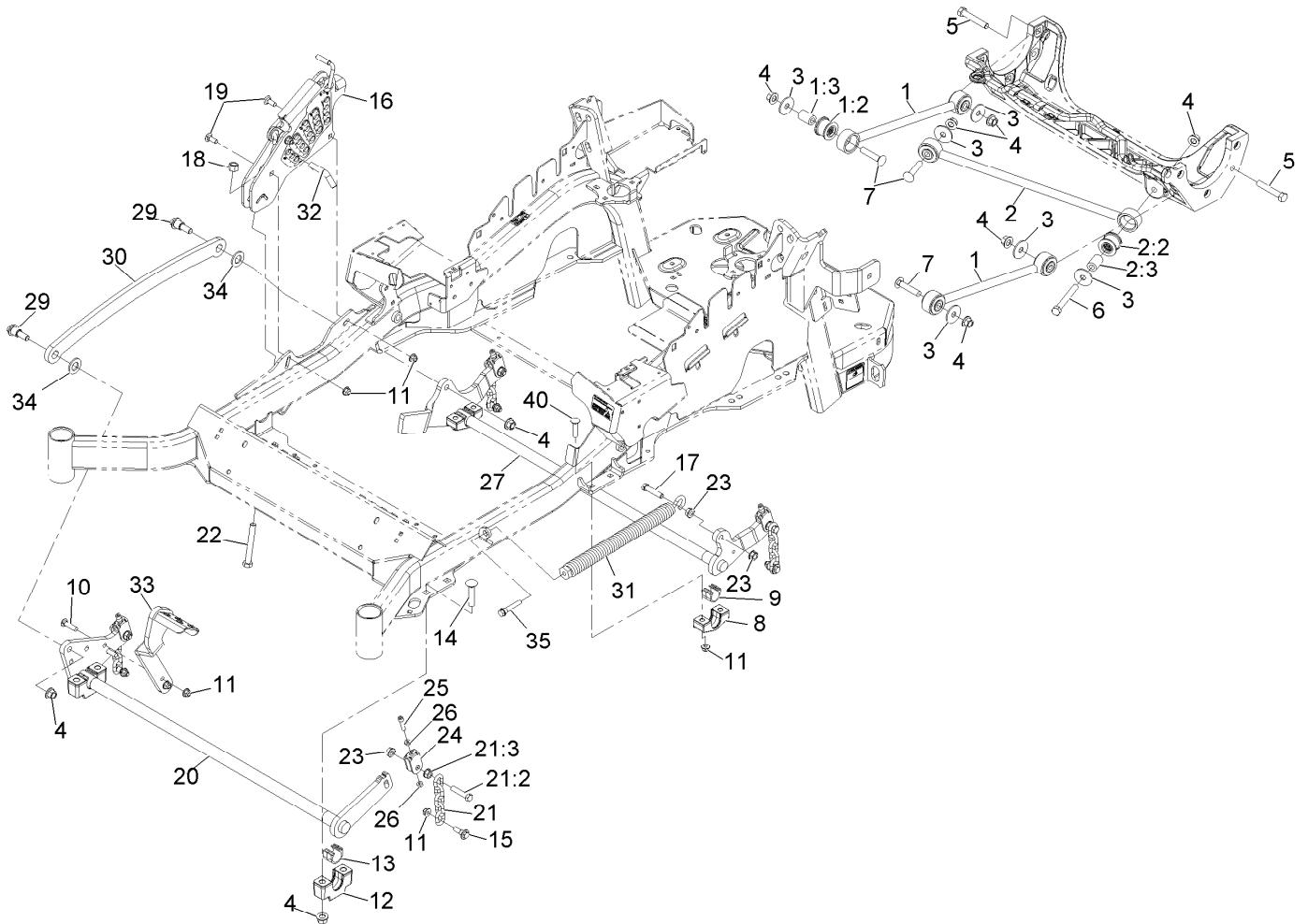

## Deck Lift Assembly

Ref.	Part Number	Qty.	Description	Ref.	Part Number	Qty.	Description
1	109-7952	2	Deck Strut ASM	16	109-7438	1	Height-Of-Cut ASM
1:2	109-5009	2	Bushing-Suspension, Rubber	17	109-9065	1	Screw-HH 7/16-14 X 2
1:3	109-5010	2	Spacer	18	3296-23	1	Nut-Nyloc 1/2-13
2	109-5013	1	Panhard Rod ASM	19	3231-2	2	Bolt-Carriage 3/8-16 X 1
2:2	109-5009	2	Bushing-Suspension, Rubber	20	116-2217-03	1	Cross Shaft Front ASM
2:3	109-5010	2	Spacer	21	116-0756	4	Deck Lift Chain ASM
3	86-1990	6	Washer	21:2	109-9065	1	Screw-HH 7/16-14 X 2
4	99-5107	12	Nut-Lock 1/2-13	21:3	32128-37	1	Nut-Whizlock 7/16-14
5	325-12	2	Screw-HH 1/2-13 X 3	22	116-0559	1	Bolt-HH 1/2-13 X 4 Tap
6	325-17	1	Screw-HH 1/2-13 X 4	23	32128-37	6	Nut-Whizlock 7/16-14
7	3233-34	3	Bolt-Carriage 1/2-13 X 2 1/2	24	109-9066	4	Yoke-Adjust, Deck
8	116-0818-03	2	Support-Bearing, Cross Shaft Rear	25	3274-18	4	Screw-Sh 5/16-18 X 1 1/4
9	109-7173	2	Bearing-Cross, Rear Shaft	26	3218-2	8	Nut-Jam 5/16-18
10	3231-4	2	Bolt-Carriage 3/8-16 X 1 1/2	27	116-0459-03	1	Lift-Deck, Rear
11	104-8301	12	Nut-Nyloc 3/8-16 Flg	29	116-0780	2	Screw-Shoulder HHF 1/2-13 X 1.12
12	109-9409	2	Support-Cross Shaft, Bearing Front	30	116-0797-03	1	Link-Lift, Deck
13	109-9410	2	Bearing-Shaft Front, Cross	31	116-0886	1	Extension Spring ASM
14	116-1700	4	Bolt-Carriage 1/2-13 X 2 1/2 Spl Neck	32	109-8757	1	Pin-HOC
15	109-9840	4	Screw-Hex Flange 3/8-16 X .80	33	116-1919-01	1	Lever-Foot
				34	3256-28	2	Washer-3/4 Sae
				35	92-7674	1	Screw-Shcs 3/8-16 X 2.212
				40	3231-5	4	Bolt-Carriage 3/8-16 X 1 3/4

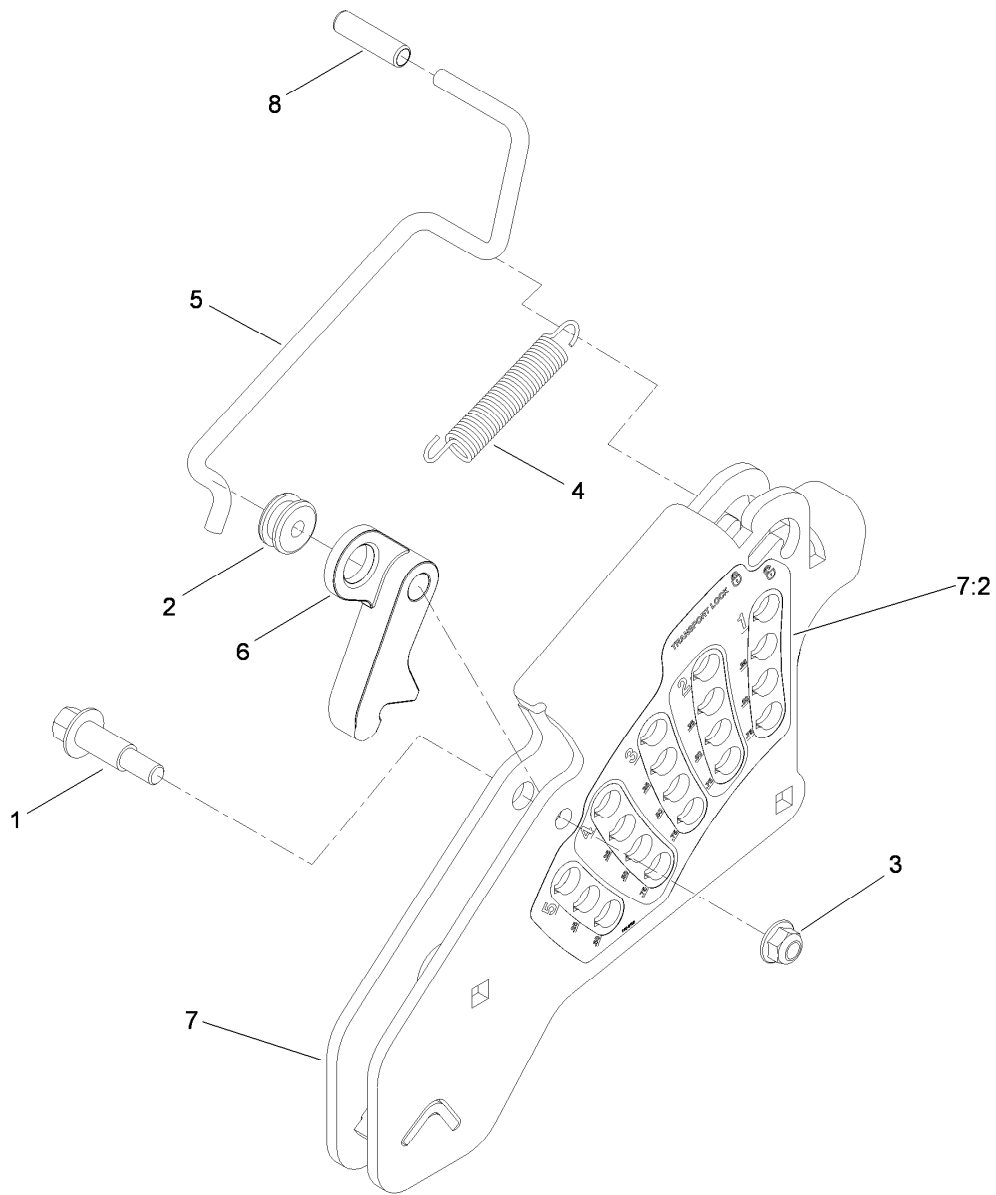

## Height-of-Cut Assembly No. 109-7438

<i>Ref.</i>	<i>Part Number</i>	<i>Qty.</i>	<i>Description</i>
1	62-1330	1	Bolt-Shoulder
2	109-7130	1	Grommet
3	104-8301	1	Nut-Flange, NI
4	109-7124	1	Spring-Extension
5	109-7128	1	Rod-Lock, Transport
6	116-0118	1	Pawl-Transport, HOC
7	109-7335	1	HOC Plate ASM
7:2	116-0752	1	Decal-HOC
8	109-8250	1	Grip-Lever

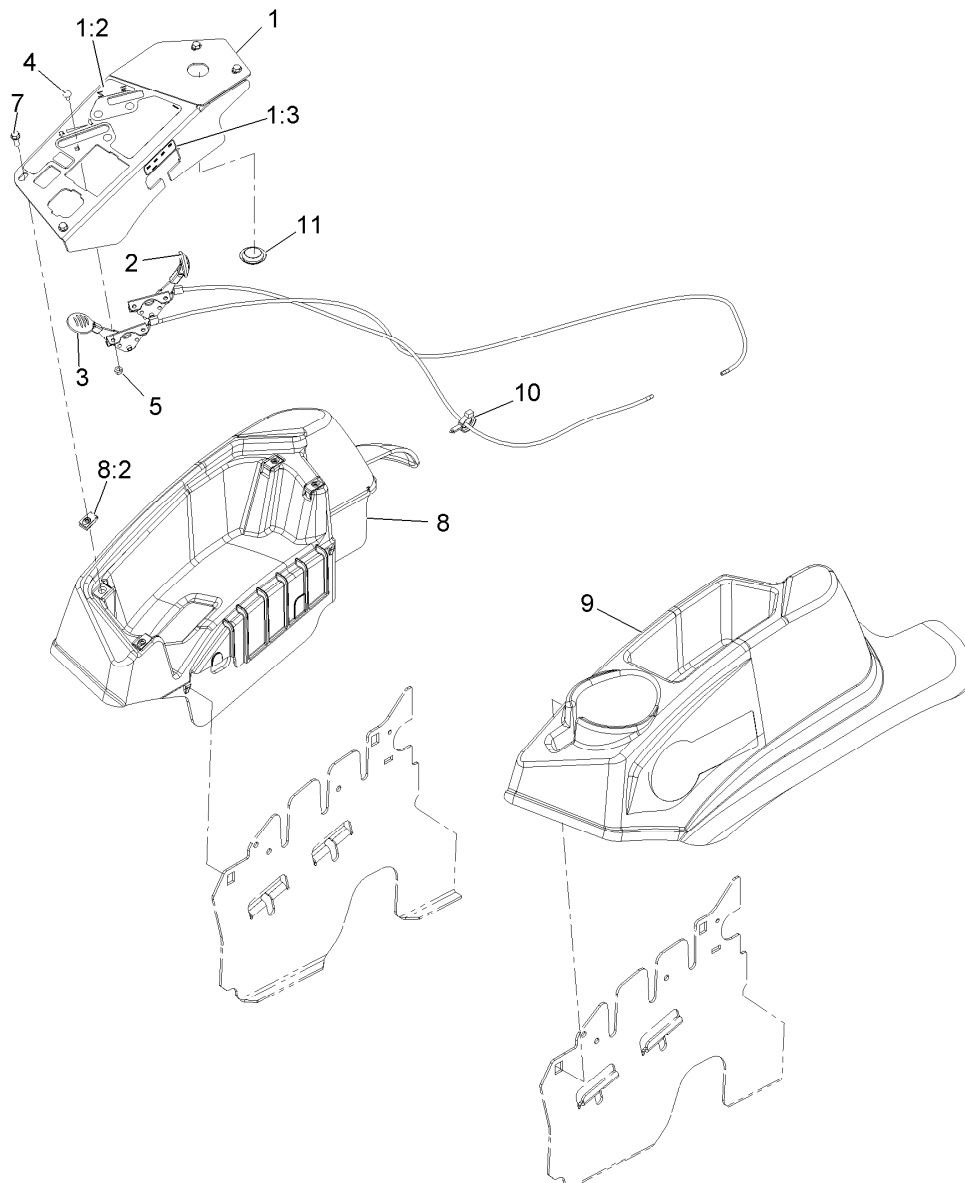

## Controls Assembly

Ref.	Part Number	Qty.	Description
1	109-8484	1	Console,Panel W/Decal
1:2	109-8483	1	Decal-Control Panel
1:3	109-7330	1	Decal-Fuse
2	109-8167	1	ASM, Choke Cable
3	116-1972	1	ASM,Throttle Cable
4	1-807513	4	Bolt-Carriage #10-24 X 1/2
5	3296-2	4	Nut-Nyloc #10-24
7	32105-15	4	Screw-Machine 1/4-20 X 3/4
8	116-1278	1	Console,RH As ASM
8:2	107069	4	Nut-Retainer-Panel 1/4-20
9	109-9457	1	Console, LH As
10	105-1853	1	Clamp-Hose
11	116-1875	1	Plug,Plastic

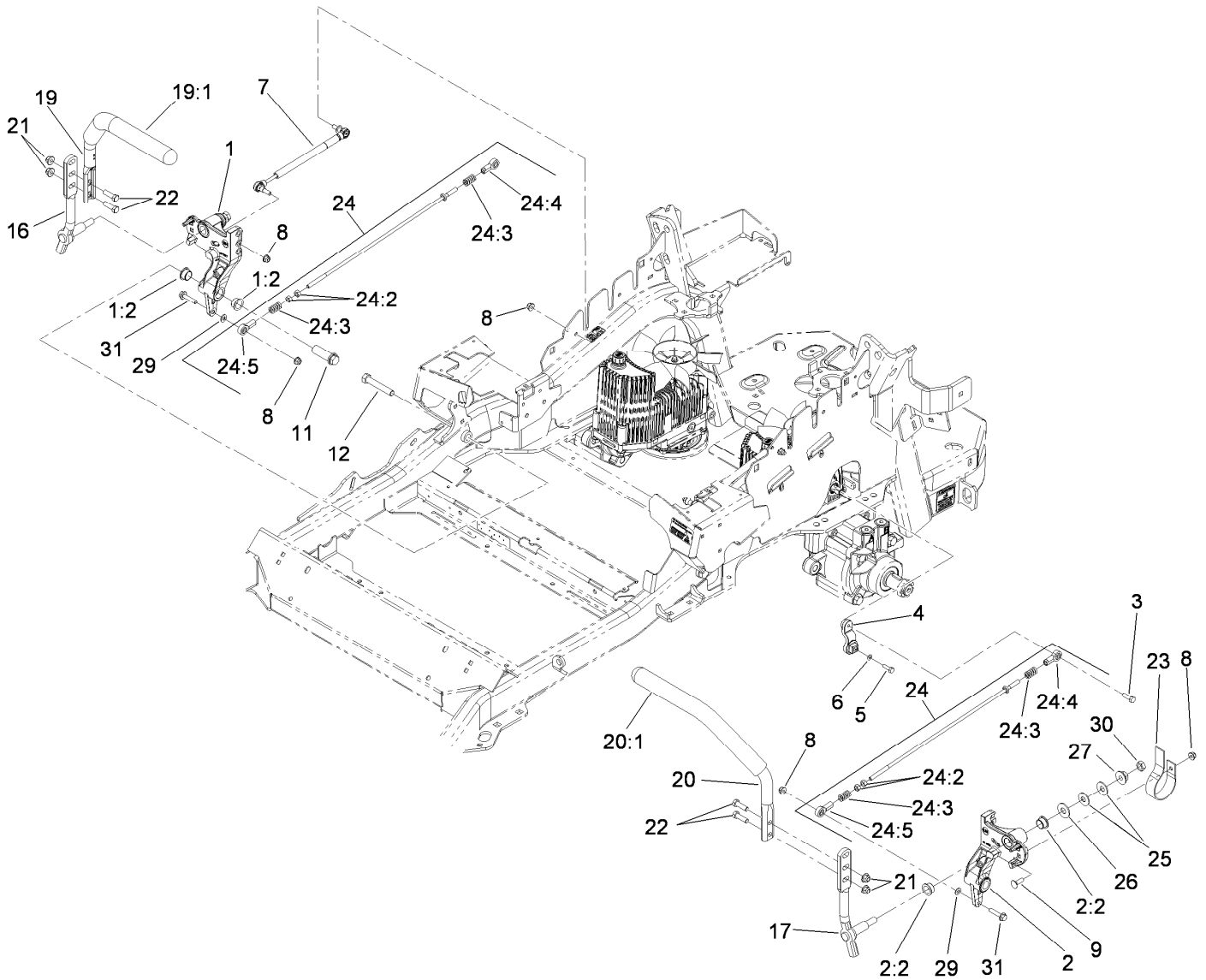

## Motion Control Assembly

Ref.	Part Number	Qty.	Description	Ref.	Part Number	Qty.	Description
1	116-0880	1	RH Motion Control And Bushing ASM	19:1	109-5668	1	Grip,Control Lever
1:2	109-8054	4	Bushing-Flanged	20	109-6590	1	ASM,Steering Handle LH
2	116-0881	1	LH Motion Control And Bushing ASM	20:1	109-5668	1	Grip,Control Lever
2:2	109-8054	4	Bushing-Flanged	21	104-8301	4	Nut-Nyloc 3/8-16 Flg
3	116-0648	2	Screw-HH 5/16-18 X 1 W/Patch ●	22	323-7	4	Screw-HH 3/8-16 X 1 1/4
4	109-4581	2	Arm-Control, Pump	23	109-5575	2	Spring-Leaf
5	9080046	2	Screw-HH 1/4-20 X 7/8 ●	24	109-8107	2	Pump Linkage Rear ASM
6	1-303435	2	Washer-Spring Disc 1/4	24:2	3219-2	2	Nut-Hex 5/16-24
7	116-0027	2	Damper-Control, Motion	24:3	1-323245	2	Spring-Compression
8	104-8300	8	Nut-Nyloc 5/16-18 Flg	24:4	1-633152	1	Balljoint
9	3230-2	2	Bolt-Carriage 5/16-18 X 1	24:5	1-543017	1	Balljoint
11	109-5891	2	Hub-Threaded	25	109-9505	4	Washer-Spring
12	325-12	2	Screw-HH 1/2-13 X 3	26	3256-6	2	Washer
16	116-0039	1	Lever-Control Motion, RH	27	32128-56	2	Nut-Hex 1/2-13 Flange
17	116-0040	1	Lever-Control Motion, LH	29	3256-23	2	Washer-5/16 Sae
19	109-6589	1	ASM,Steering Handle RH	30	3218-5	2	Nut-Jam 1/2-13
				31	115-1794	2	Screw-Hex Flange 5/16-18 X 1 1/2

● Use Pro-Lock, Nut Type (P/N 1-840022, .5ml tube) on threads.

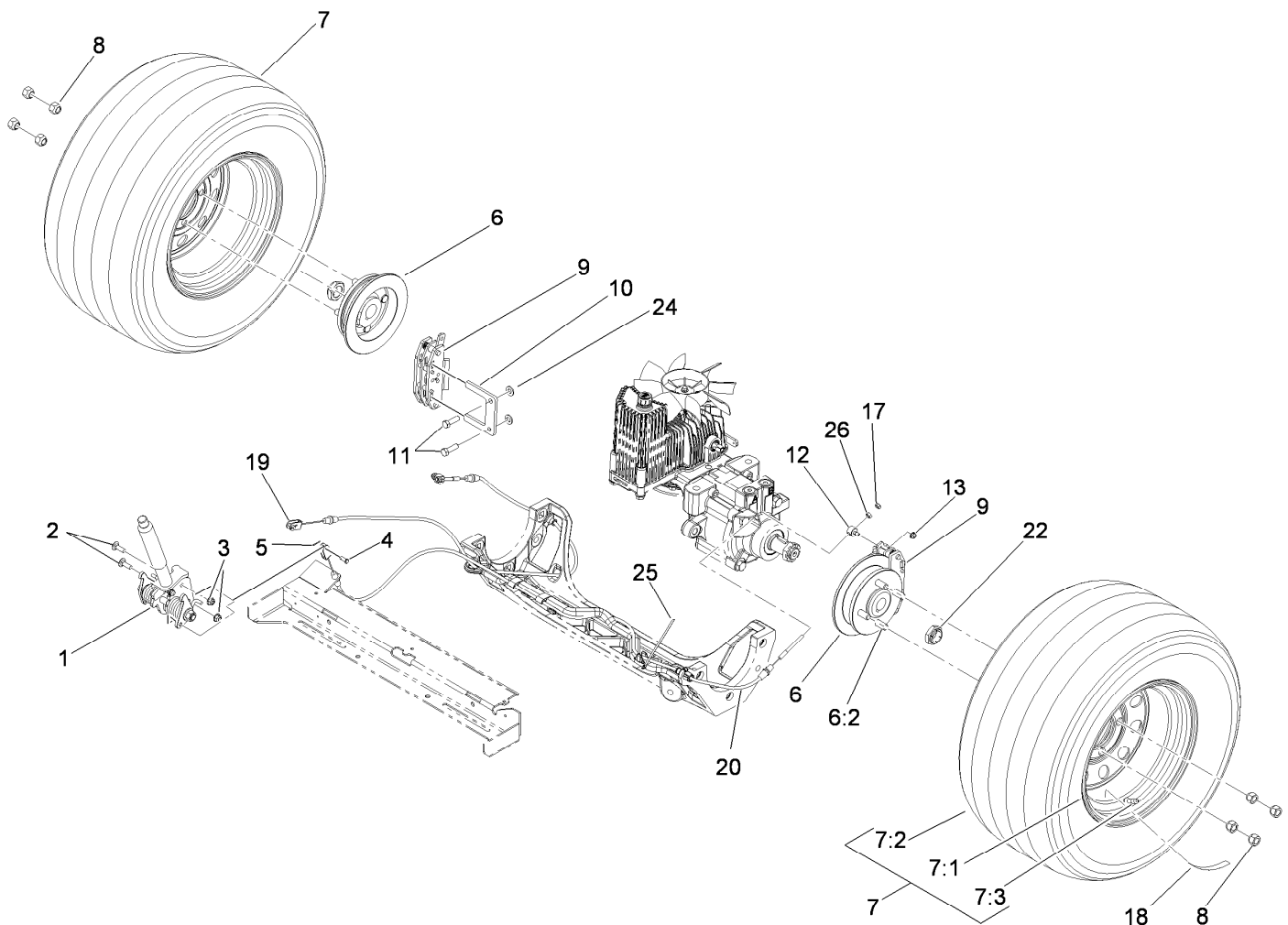

## Rear Wheel and Park Brake Assembly

Ref.	Part Number	Qty.	Description	Ref.	Part Number	Qty.	Description
1	116-1878	1	Brake Handle ASM	10	109-0958	2	Plate-Mount, Brake
2	3230-2	2	Bolt-Carriage 5/16-18 X 1	11	92-5727	4	Screw-HH 3/8-16 X 1 1/4 Patch Lock
3	104-8300	2	Nut-Nyloc 5/16-18 Flg	12	112-8379	2	Swivel
4	60-1730	2	Pin-Clevis	13	104-7201	2	Nut-Nyloc 1/4-20 Flg
5	3272-1	2	Pin-Cotter 1/16 X 1/2	17	3296-13	2	Nut-Nyloc 1/4-28
6	116-1746	2	Wheel Hub ASM	18	116-2643	2	Decal-Wheel Nut Torque
6:2	116-1696	4	Stud-Wheel	19	115-3584	1	Cable
7	115-3589	2	Wheel And Tire ASM	20	115-3585	1	Cable
7:1	109-2875	1	Rim ASM	22	116-1399	2	Locknut, Wheel Motor
7:2	1-653160	1	Tire	24	3256-24	4	Washer-3/8 Sae
7:3	232-27	1	Stem-Valve	25	116-0940	1	Tie-Cable
8	242-50	8	Nut-Lug 1/2-20	26	3219-1	2	Nut-Hex 1/4-28
9	109-2889	2	Caliper-Brake				



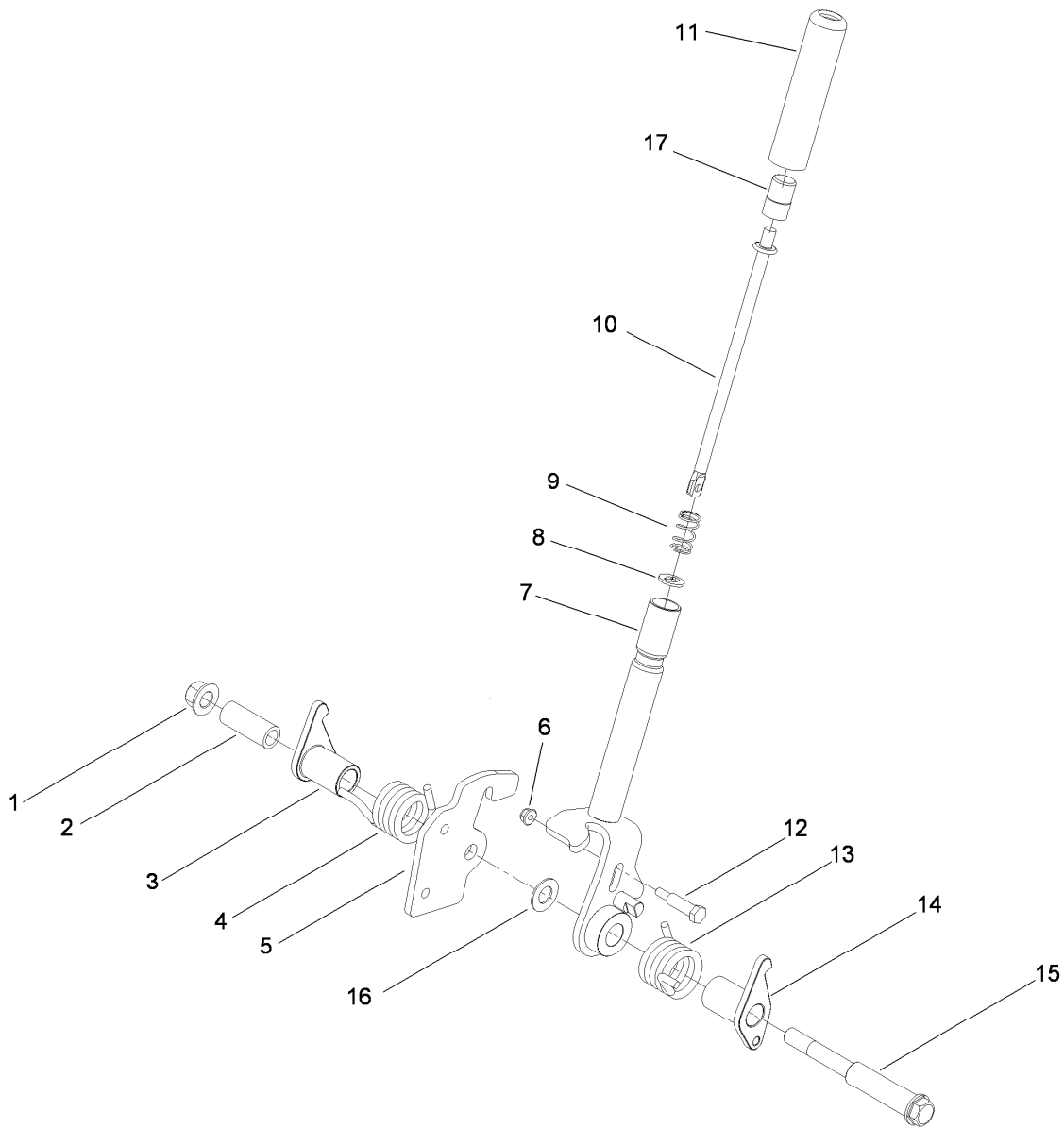

## Brake Handle Assembly No. 116-1878

<i>Ref.</i>	<i>Part Number</i>	<i>Qty.</i>	<i>Description</i>	<i>Ref.</i>	<i>Part Number</i>	<i>Qty.</i>	<i>Description</i>
1	99-5107	1	Nut-Lock	10	115-3581	1	Rod-Release, Brake
2	117-0380	1	Spacer	11	115-3592	1	Grip
3	115-3580	1	Arm-Brake, LH	12	112-8387	1	Bolt-Shoulder
4	117-0376	1	Spring-Torsion, RH	13	117-0375	1	Spring-Torsion, LH
5	115-3574	1	Plate-Latch	14	115-3579	1	Arm-Brake, RH
6	104-7201	1	Nut-HF	15	117-0379	1	Bolt-Shoulder
7	116-1876-03	1	Brake Handle ASM	16	3256-26	1	Washer-Flat
8	114-1207	1	Washer-Special	17	115-2750	1	Knob
9	114-8187	1	Spring-Compression				

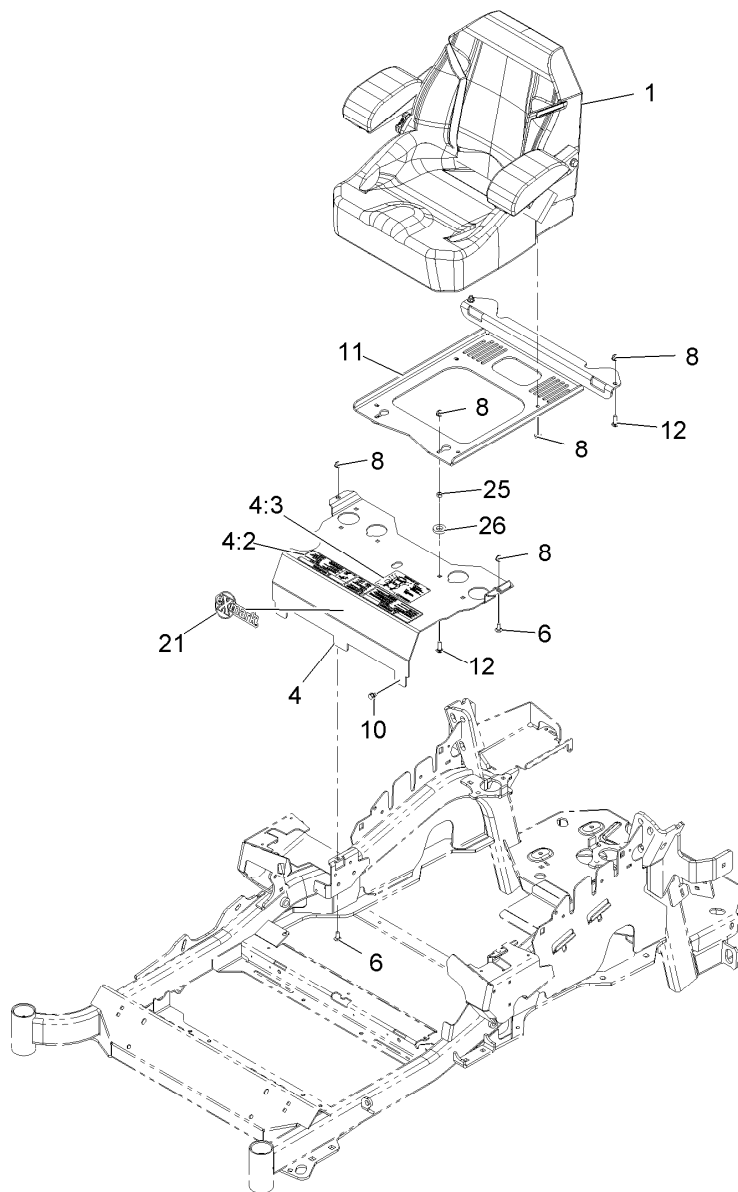

## Seat Assembly

Ref.	Part Number	Qty.	Description
1	116-4474	1	Seat,Exmark Standard Service
4	116-2323	1	Mount-Seat
4:2	109-7069	1	Decal-Console
4:3	116-0211	1	Decal-Service Aid
6	3230-23	2	Bolt-Carriage 5/16-18 X 3/4 Short Neck
8	104-8300	10	Nut-Nyloc 5/16-18 Flg
10	9266934	2	Screw-HWH 5/16 X 1/2 Tf
11	116-0192-03	1	Plate,Seat Support As
12	3230-22	4	Bolt-Carriage 5/16-18 X 1 Sp
21	103-2883	1	Decal,Exmark Logo
25	3217-6	2	Nut-Hex 5/16-18
26	1-323539	2	Spacer-Blade Drive

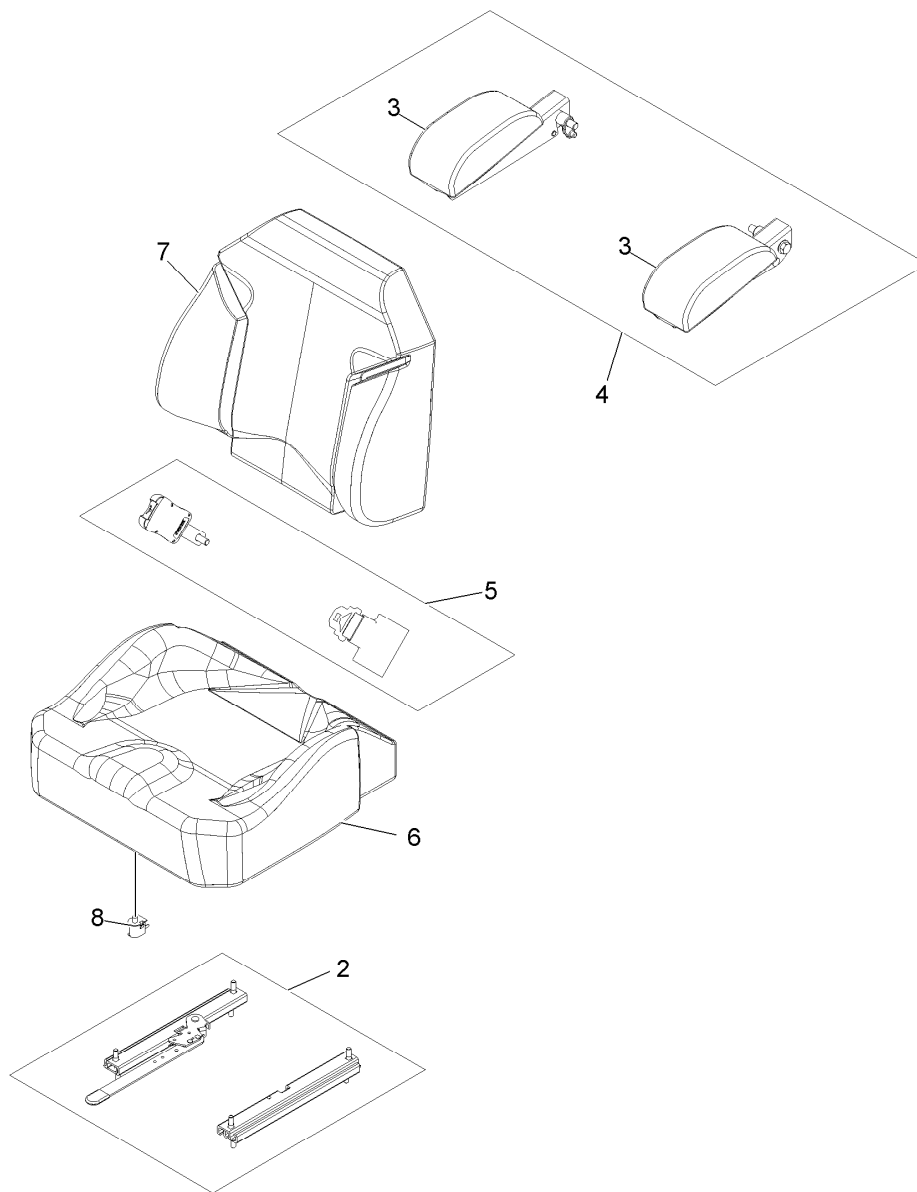

## Seat W/Tracks Assembly No. 116-4474

<i>Ref.</i>	<i>Part Number</i>	<i>Qty.</i>	<i>Description</i>
2	109-9801	1	Seat Track Set
3	109-9802	1	Arm Rest Pad Set
4	109-9803	1	Arm Rest Set
5	109-9805	1	Seat Belt Kit
6	116-4925	1	Cover,Cushion
7	116-4926	1	Cover,Back
8	82-2190	1	Switch

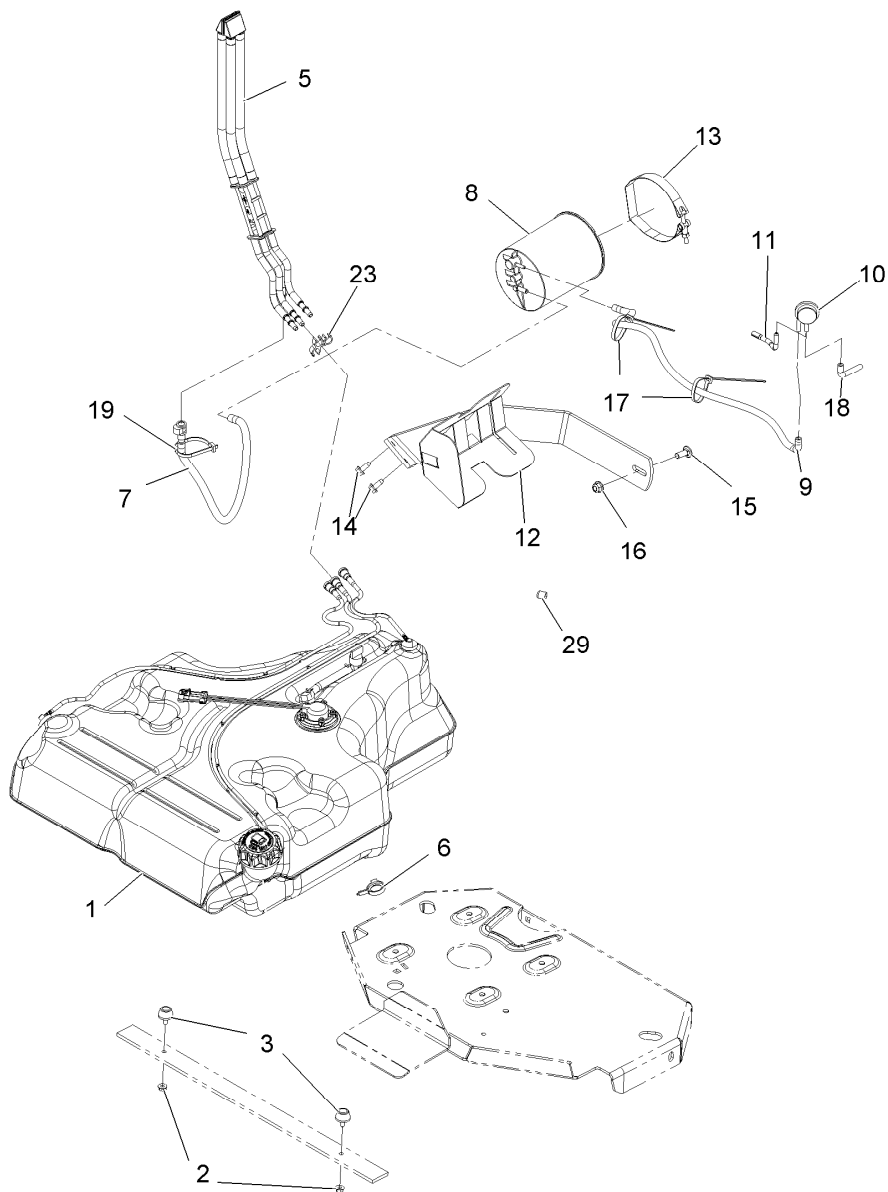

## Fuel Tank Mounting Assembly

Ref.	Part Number	Qty.	Description	Ref.	Part Number	Qty.	Description
1	116-3979	1	Fuel Tank ASM	12	116-1433-03	1	Mount-Canister
2	32128-33	2	Nut-Whizlock 1/4-20	13	116-2228	1	Clamp-T-Bolt
3	109-2365	2	Rubber Bumper ASM (W/Stud)	14	32144-70	2	Screw-HWH 5/16-18 X 3/4 Tf
5	109-9491	1	Fuel Manifold Vent ASM	15	3231-22	1	Bolt-Carriage 3/8-16 X 1
6	105-1853	1	Clamp-Hose	16	104-8301	1	Nut-Nyloc 3/8-16 Flg
7	116-1702	1	Vent Hose ASM	17	1-303335	2	Tie-Cable 7 15/16 (Large)
8	116-1442	1	Canister-Carbon, 1200Cc	18	116-2233	1	Hose-Formed
9	116-2231	1	Formed-Hose	19	1-303335	1	Tie-Cable 7 15/16 (Large)
10	116-2232	1	Valve-Control, Vacuum	23	116-3370	1	Clip-Spacer 1/2"
11	116-2394	1	Hose-Formed	29	116-4464	1	Plug,Port

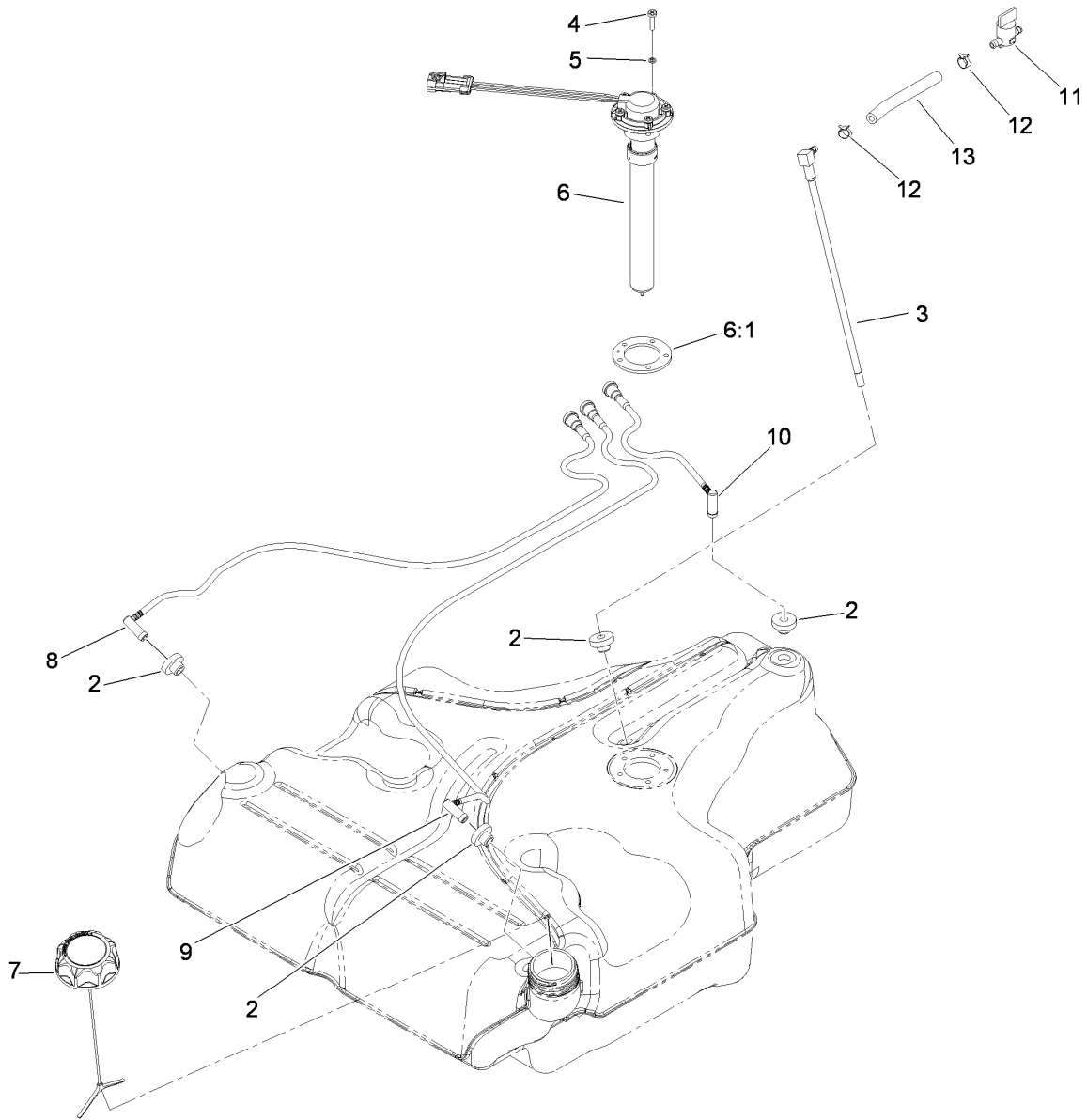

## Fuel Tank Assembly No. 116-3979

Ref.	Part Number	Qty.	Description
2	46-6560	4	Bushing
3	116-2459	1	Fuel Line Kit (With Grommet)
4	9107944	5	Screw-Pan 10-24 X 3/4
5	3253-17	5	Washer-Lock 3/16
6	116-0003	1	Sender-Fuel Level
6:1	109-9620	1	Gasket-Sender, Fuel
7	116-1704	1	Cap-Fuel, Ratcheting
8	116-2460	1	RH Vent Line Kit (With Grommet)
9	116-2461	1	LH Vent Line Kit (With Grommet)
10	116-2462	1	Rear Vent Line Kit (With Grommet)
11	1-603770	1	Valve-Fuel
12	2412-98	2	Clamp-Hose
13	109-0650	1	Hose-Fuel

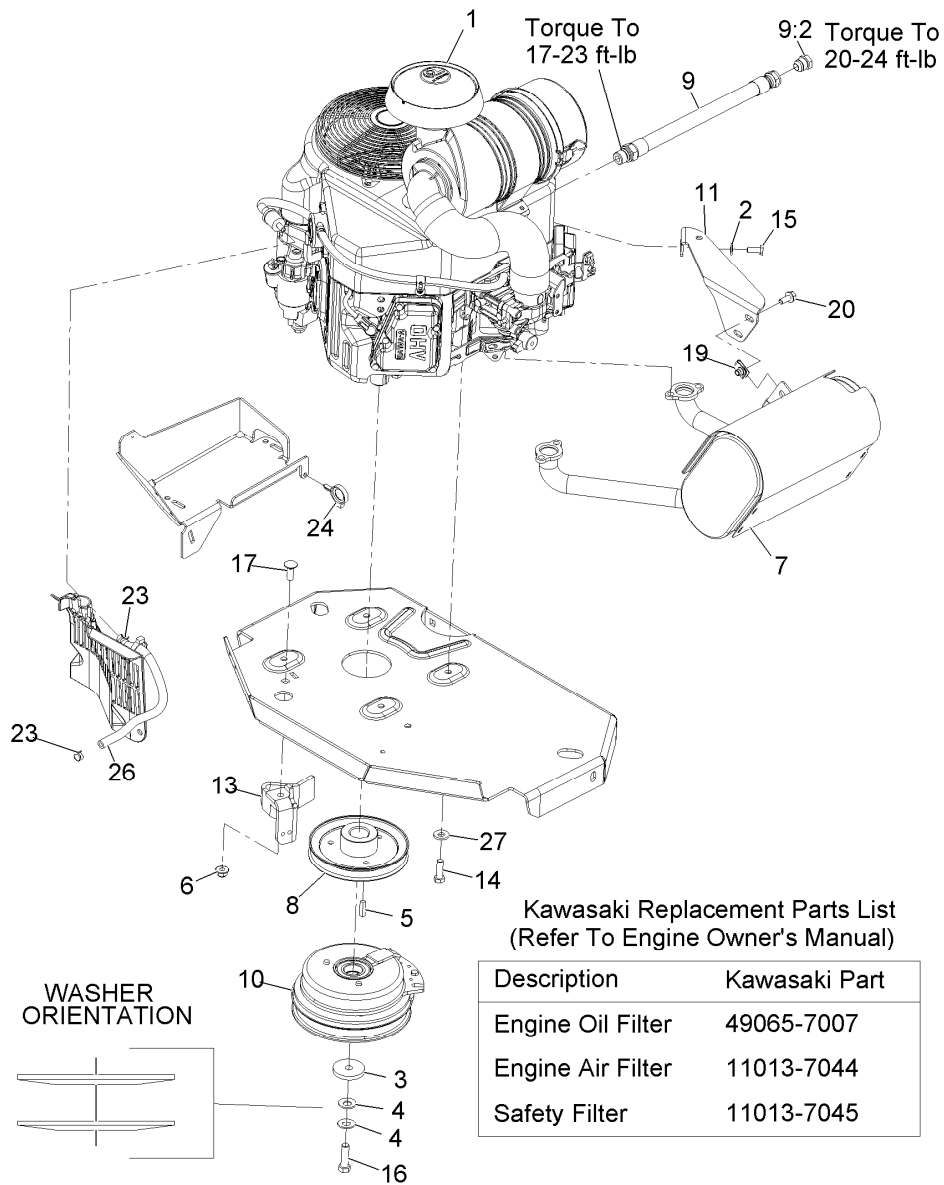

## Engine Assembly

Ref.	Part Number	Qty.	Description
1		1	Engine-Kawasaki, Fx691V-As00 ●■
2	1-303334	1	Washer-Spring Disc 5/16
3	109-6919	1	Washer-Clutch
4	1-603610	2	Washer-Spring Disc 7/16
5	1-807259	1	Key-Machine 1/4 X 1/4 X 1
6	104-8301	1	Nut-Nyloc 3/8-16 Flg
7	116-1715	1	Muffler
8	109-9905	1	Sheave
9	109-4490	1	Oil Drain Hose ASM ▲
9:2	109-1012	1	Plug
10	116-1620	1	Clutch Kit
11	116-1435	1	Bracket-Muffler

Ref.	Part Number	Qty.	Description
13	116-2612-01	1	Clutch-Anchor
14	323-7	4	Screw-HH 3/8-16 X 1 1/4
15	33114-020	1	Screw-HH M8-1.25 X 20Mm
16	109-9761	1	Screw-HH 7/16-20 X 1 1/2 W/Loctite ◆
17	3231-22	1	Bolt-Carriage 3/8-16 X 1
19	94-2413	2	U-Nut
20	3234-5	2	Screw-HH Flg 5/16-18 X 3/4
23	2412-98	2	Clamp-Hose
24	105-1853	1	Clamp-Hose
26	109-0296	1	Hose-Fuel Line 15"
27	98-5975	4	Washer-Spring Disc 3/8

● Not serviced separately

▲ Use a Teflon Pipe Sealant or equivalent on threads.

◆ Use Pro-Lock, Nut Type (P/N 1-840022, .5ml tube) on threads.

■ Obtain parts from [www.kawpowerepc.com](http://www.kawpowerepc.com)

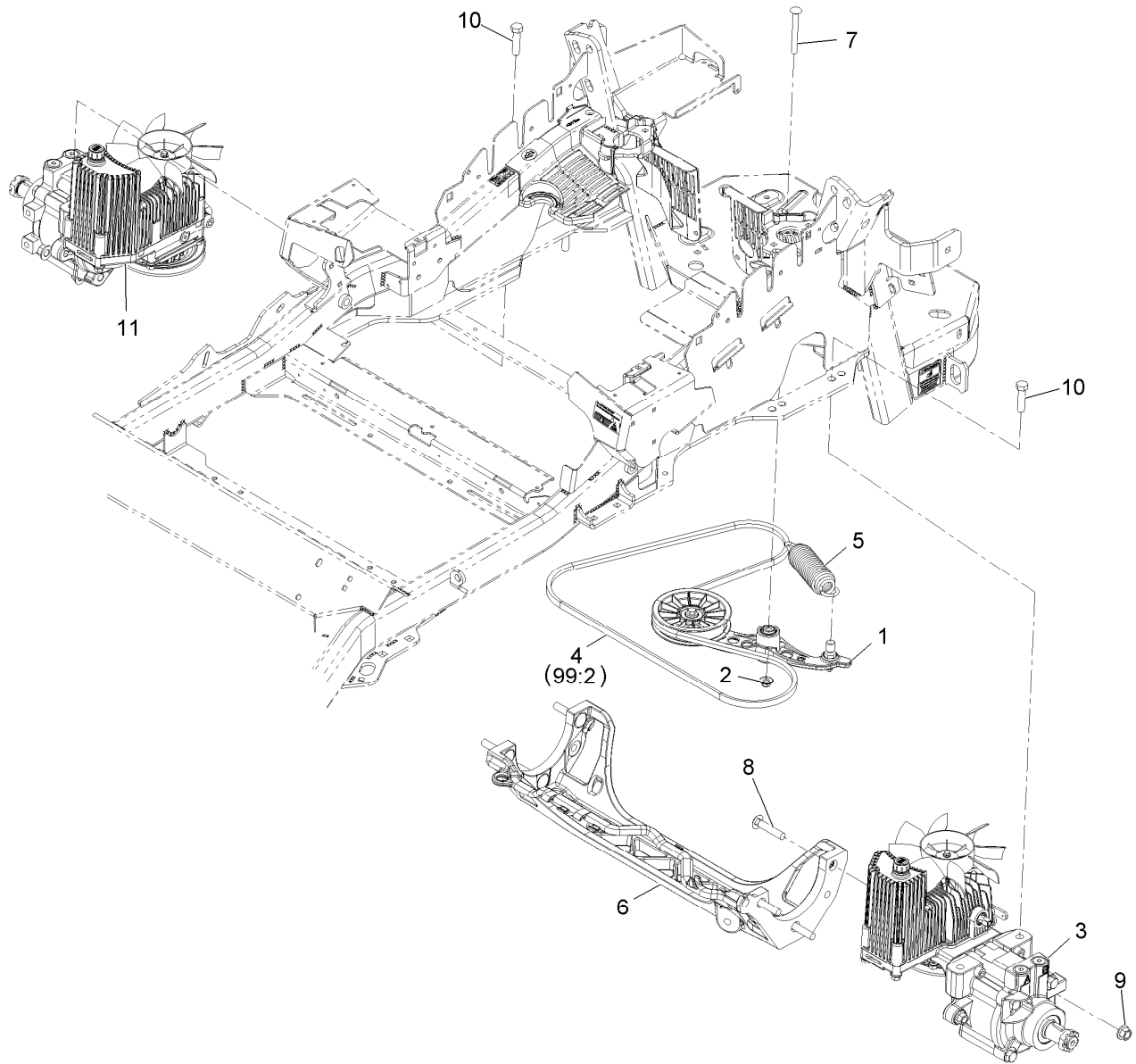

## Hydraulic Assembly

Ref.	Part Number	Qty.	Description	Ref.	Part Number	Qty.	Description
1	116-1255	1	Pump Idler ASM	10	325-8	4	Screw-HH 1/2-13 X 1 1/4
2	109-6658	1	Nut-Nyloc 3/8-16 Flg	11	116-1323	1	RH Hydro ASM (12Cc W/Check)
3	116-1322	1	LH Hydro ASM (12Cc W/Check)	99	109-9828	1	Bottle-Oil, 32Oz Hydraulic ●
4	109-3388	1	Belt	99	116-0164	1	Filter-Hydro ●
5	116-0133	1	Extension-Spring	99	116-1218	1	Bottle,Oil 1 Gallon Hydraulic ●
6	109-9375	1	Cradle-Hydro	99	116-3270	1	Kit, Hydro Service ●
7	116-1502	1	Bolt-Carriage Shoulder 3/8-16 X 3 1/2	99:1	109-9828	4	Bottle-Oil, 32Oz Hydraulic ●
8	3233-34	6	Bolt-Carriage 1/2-13 X 2 1/2	99:2	109-3388	1	Belt
9	99-5107	6	Nut-Lock 1/2-13	99:3	116-0164	2	Filter-Hydro ●

● Not illustrated

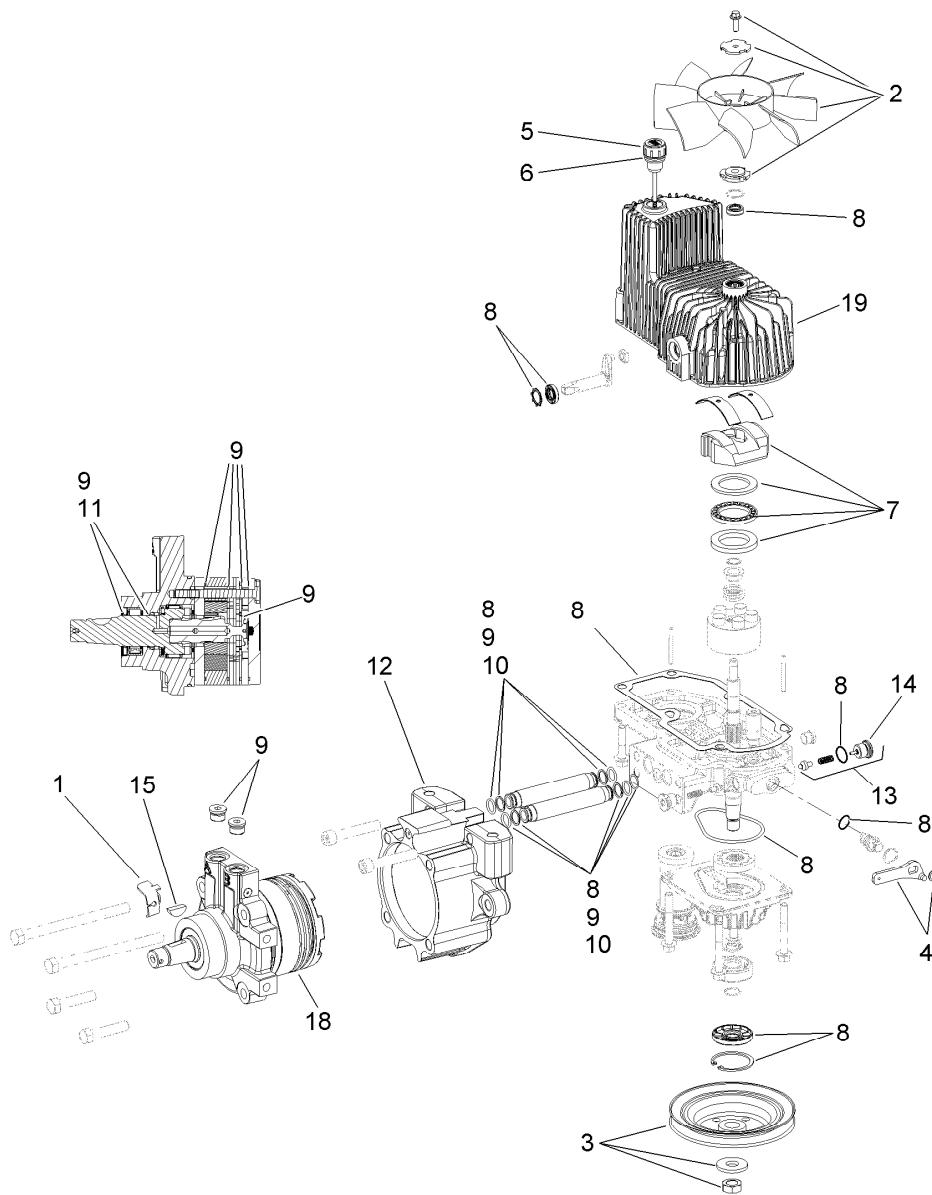

## LH Hydro Assembly No. 116-1322

Ref.	Part Number	Qty.	Description	Ref.	Part Number	Qty.	Description
1	116-1758	1	Bracket-Anchor, Cable	10	116-1370	1	Tube Seal Kit
2	116-0233	1	Fan Kit	11	116-1371	1	Output Shaft Seal Kit
3	116-0234	1	Pulley Kit	12	116-2992	1	Cup-Nose Hydro Dry
4	116-0235	1	Handle-Bypass Valve, Hydro	13	116-1630	1	Check Valve ASM
5	116-0236	1	Dipstick-Hydro W/Gasket	14	116-1631	1	Check Plug W/O-Ring
6	116-0237	1	Gasket-Dipstick, Hydro	15	3257-42	1	Key-Woodruff 5/16 X 1
7	116-1367	1	Swash Block Kit	18	116-2988	1	Motor-Wheel LH Dry 240Cc
8	116-1368	1	Pump Seal Kit	19	116-3287	1	Housing-LH
9	116-1369	1	Motor Seal Kit	99	116-1373	1	Flow Test Kit ●

● Not illustrated



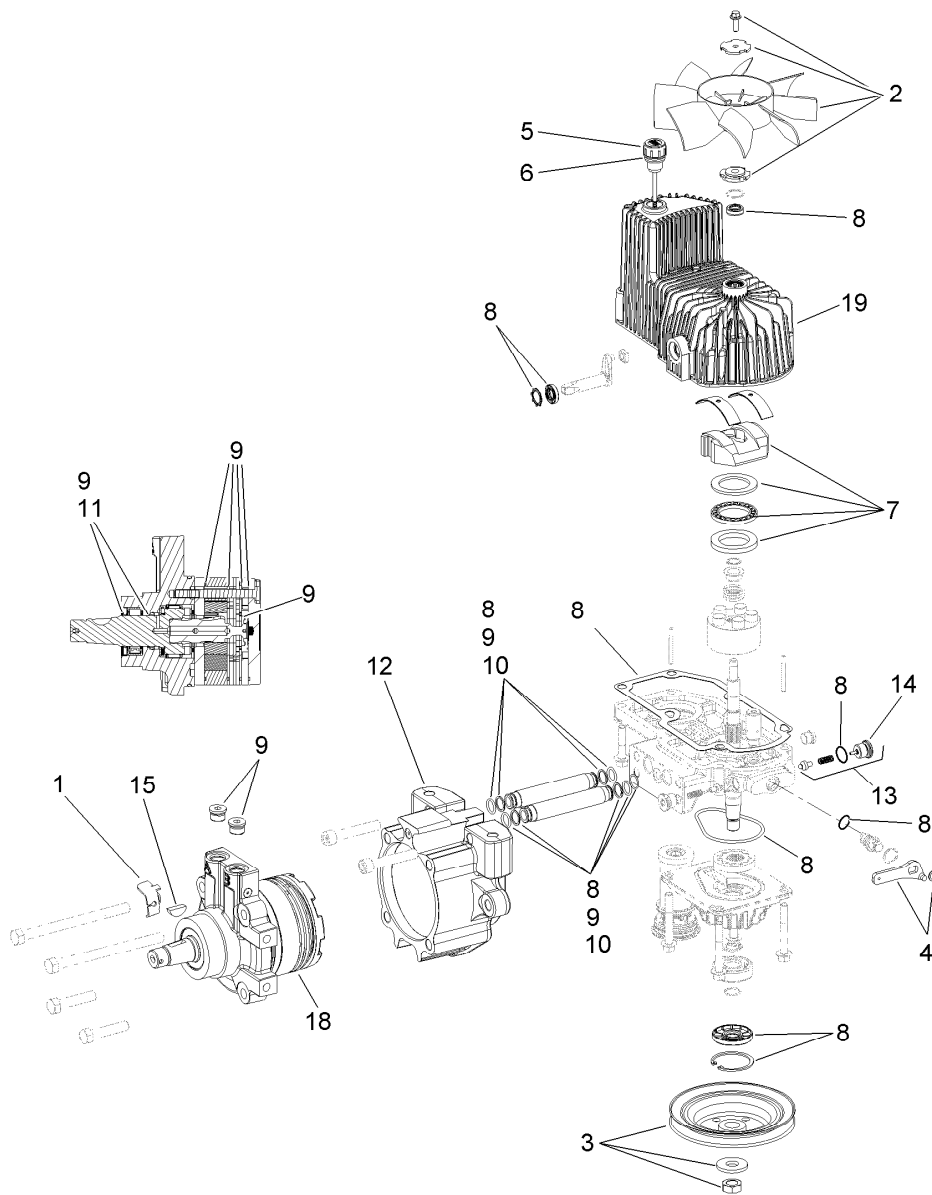

## RH Hydro Assembly No. 116-1323

<i>Ref.</i>	<i>Part Number</i>	<i>Qty.</i>	<i>Description</i>	<i>Ref.</i>	<i>Part Number</i>	<i>Qty.</i>	<i>Description</i>
1	116-1758	1	Bracket-Anchor, Cable	10	116-1370	1	Tube Seal Kit
2	116-0233	1	Fan Kit	11	116-1371	1	Output Shaft Seal Kit
3	116-0234	1	Pulley Kit	12	116-2992	1	Cup-Nose Hydro Dry
4	116-0235	1	Handle-Bypass Valve, Hydro	13	116-1630	1	Check Valve ASM
5	116-0236	1	Dipstick-Hydro W/Gasket	14	116-1631	1	Check Plug W/O-Ring
6	116-0237	1	Gasket-Dipstick, Hydro	15	3257-42	1	Key-Woodruff 5/16 X 1
7	116-1367	1	Swash Block Kit	18	116-2989	1	Motor-Wheel RH Dry 240Cc
8	116-1368	1	Pump Seal Kit	19	116-3288	1	Housing-RH
9	116-1369	1	Motor Seal Kit	99	116-1373	1	Flow Test Kit ●

● Not illustrated

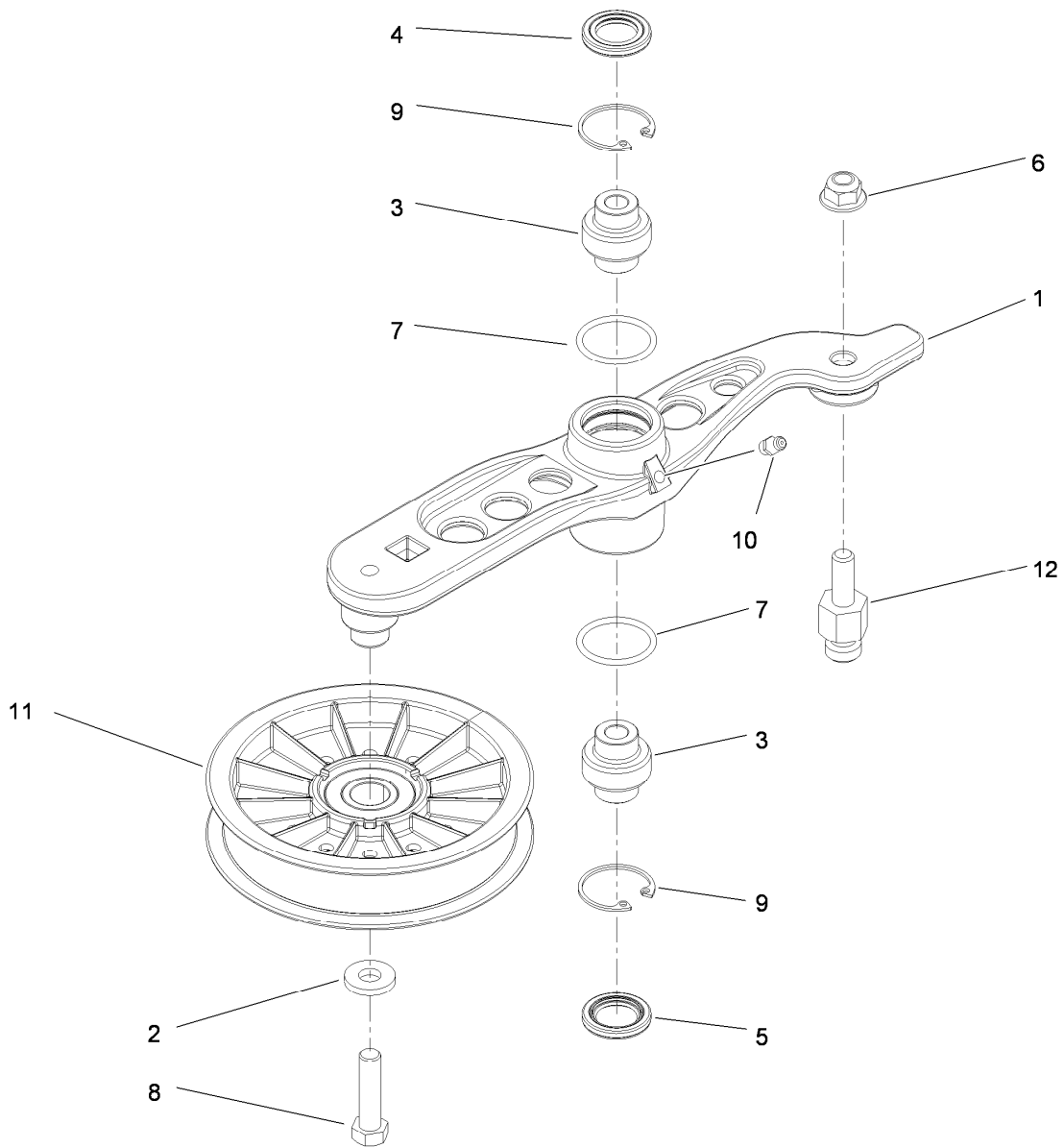

## Pump Idler Assembly No. 116-1255

Ref.	Part Number	Qty.	Description
1		1	Arm-Pump, Idler ●
2	43-0940	1	Spacer-Hub, Blower
3	103-3504	2	Bearing-Spherical
4	103-3505	1	Seal-Double Lip
5	103-3506	1	Seal-Single Lip
6	109-6658	1	Nut-Nyloc 3/8-16 Flg
7	106-7159	2	O-Ring
8	323-8	1	Screw-HH 3/8-16 X 1 1/2
9	32120-10	2	Ring-Retaining
10	302-19	1	Zerk-1/4-28 Str
11	109-8076	1	Pulley-Idler
12	116-3467	1	Pin, Spring Anchor

● Not serviced separately

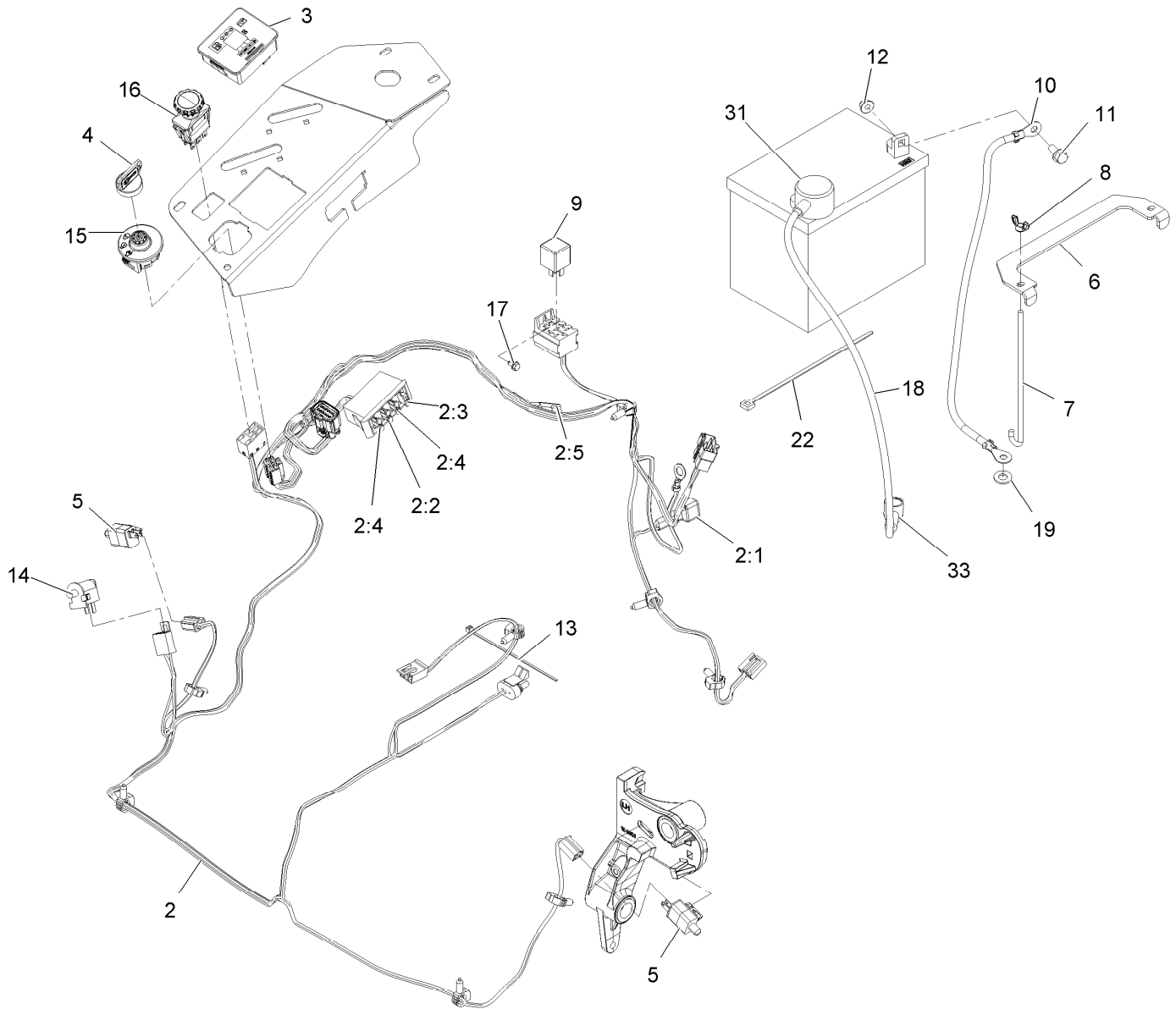

## Electrical Assembly

Ref.	Part Number	Qty.	Description	Ref.	Part Number	Qty.	Description
2	115-2796	1	Harness-Wire, Main ●	10	114-1218	1	Cable-Battery, Negative
2:1	103-3895	1	Diode-Tvs	11	3234-5	2	Screw-HH Flg 5/16-18 X 3/4
2:2	218-578	1	Fuse-Blade, 10 Amp	12	104-8300	2	Nut-Nyloc 5/16-18 Flg
2:3	109355	1	Fuse-Blade, 15 Amp	13	1-303287	3	Tie-Cable 5 1/2 (Small)
2:4	109102	2	Fuse-Blade, 25 Amp	14	82-2190	1	Switch
2:5	116-0053	1	Cap-Plug	15	117-2221	1	Switch-Ignition
3	117-3882	1	Fuel/Hour Meter ASM	16	116-0124	1	Switch-PTO, 10A
4	1-603511	1	Key-Ignition	17	104-2065	1	Screw-HWH #10-24 X 3/8
4	103-2106	1	Key-Exmark Logo	18	115-3864	1	Cable-Battery, Positive
5	110-6765	2	Switch-Single Pole No	19	3256-24	1	Washer-3/8 Sae
6	116-0042-03	1	Strap-Tie Down, Battery	22	1-303335	1	Tie-Cable 7 15/16 (Large)
7	1-633651	2	Bolt-Holddown	31	109-2407	1	Insulator-Battery
8	1-543792	2	Wingnut-Nyloc 1/4-20	33	1-543393	1	Insulator-Solenoid
9	1-643275	1	Relay-12Vdc 40 Amp				

● Use dielectric grease on all wiring harness connectors.

**Notes:**

**Notes:**

**Notes:**

# EXMARK® MAINTENANCE

## MAXIMIZE THE PERFORMANCE OF YOUR EXMARK.

### 4-CYCLE PREMIUM ENGINE OIL

Part No. 116-3373

Both SAE 30 and SAE 10W-30 in one bottle.

Contains increased levels of zinc and phosphorus for better lubricity.

No Viscosity Index Improvers that tend to shear down in high heat.

Synthetic formulation.

Gas & Diesel compatible.

Anti-corrosion additives.

API 'SL' and JASO rated with wet clutch compatibility for other machines.

### PREMIUM HYDRO OIL

Part No. 109-9828

Commercial quality for tough, high-heat conditions.

Designed specifically for zero-turn mower hydraulic systems.

Superior shear resistance under heavy loads.



Available from your local Exmark dealer. Find your closest dealer at [exmark.com](http://exmark.com)

## SEE EXMARK'S COMPLETE LINE OF ACCESSORIES AND OPTIONS

### MID-MOUNT RIDING ACCESSORIES AND OPTIONS

CUSTOM RIDE SEAT SUSPENSION SYSTEM	OPERATOR CONTROLLED DISCHARGE
FULL SUSPENSION SEAT	ROLL OVER PROTECTION SYSTEM (ROPS)
DECK LIFT ASSIST KIT	SUN SHADE
HITCH KIT	TRASH CONTAINER
LIGHT KIT	TURF STRIPER
12V POWER PORT	ULTRA VAC COLLECTION SYSTEM
MICRO-MULCH SYSTEM	ULTRA VAC QUICK DISPOSAL SYSTEM

### OUT-FRONT RIDING ACCESSORIES AND OPTIONS

CUSTOM RIDE SEAT SUSPENSION SYSTEM	SNOW BLADE
DUAL-TAIL WHEEL	SNOWBLOWER
FLOOR PAN EXTENDER	SUN SHADE
HITCH KIT	TRASH CONTAINER
LIGHT KIT	ULTRA VAC COLLECTION SYSTEM
MICRO-MULCH SYSTEM	ULTRA VAC QUICK DISPOSAL SYSTEM
ROLL OVER PROTECTION SYSTEM (ROPS)	WEATHER CAB

### WALK-BEHIND ACCESSORIES AND OPTIONS

GRASS CATCHER	TURF STRIPER
MICRO-MULCH SYSTEM	STANDON

Place Model No. and Serial No.  
Label Here (Included in the Literature  
Pack) or Fill in Below

Model No. \_\_\_\_\_

Serial No. \_\_\_\_\_

Date Purchased \_\_\_\_\_

Engine Model No. and Spec. No. \_\_\_\_\_

Engine Serial No. (E/No) \_\_\_\_\_

© 2010 Exmark Mfg. Co., Inc.  
Industrial Park Box 808  
Beatrice, NE 68310  
All Rights Reserved

Part No. 4500-870 Rev. A  
(402) 223-6300  
Fax (402) 223-5489  
Printed in the USA.

