

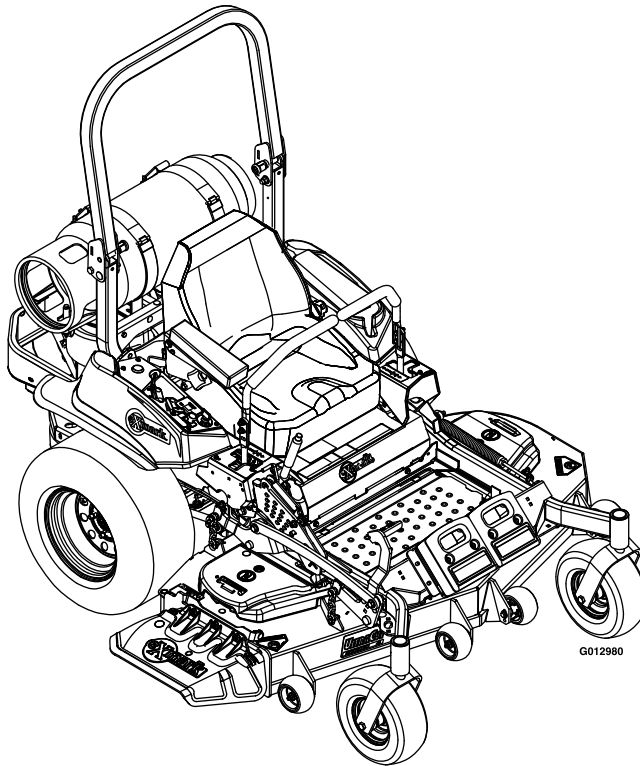

LAZER Z[®] **S-SERIES PROPANE**

Model No. LZS29PKA724—Serial No. 920000 and Up

Picture below may not reflect actual product.



Parts Manual

Part No. 4500-831 Rev. B

Ordering Replacement Parts

To order replacement parts, please supply the part number, the quantity, and the description of each part desired.

Understanding Reference Numbers

Each identified part in an illustration has a reference number. The reference number for a part also appears in the parts list, along with other information about the part.

This catalog uses two special reference number formats, one to indicate parts in a service assembly and another to indicate the quantity of a given part in an illustration.

Service Assembly Reference Numbers

Parts in service assemblies have reference numbers in the form a:b. The a represents the reference number of the entire service assembly and the b represents a sequential number unique to each part within the service assembly.

For example, a wheel assembly might be identified by reference number 6, the tire by 6:1, the valve by 6:2, and the wheel by 6:3. When you order the assembly identified by reference number 6, you receive all parts identified by reference numbers 6:1, 6:2, and 6:3. However, you may also order any part individually. Reference numbers of this type appear in illustration and in parts lists.

Reference Numbers Indicating Quantity

In an illustration, if a reference number indicates more than one part, the reference number has the form nX y. The n represents the quantity of the part, the X is the multiplication symbol, and the y represents the reference number.

For example, in an illustration, the reference number 2X 37 means that two of the parts identified by reference number 37 are indicated.

List of Abbreviations

AR: as required	HOC: height-of-cut	RRB: rear roller brush
ASM: assembly	HSBH: hex socket button head	SFH: slotted fillister head
BBC: blade brake control	HSFH: hex socket flat head	SHH: slotted hex head
BHTF: button head thread forming	HSH: hex socket head	SHWH: slotted hex washer head
CARR: carriage	HWH: hex washer head	SPH: slotted pan head
CCW: counter clockwise	HWTF: hex washer head thread forming	SQH: square head
CW: clockwise	HYD: hydraulic	SRH: slotted round head
DEG: degrees	LH: left hand	STD: standard
DPA: Dual Point Adjustment	LP: Liquid Propane	TAP: self tapping
ECM: electronic control module	NI: nylon insert	TTH: torx truss head
EXT: external	NPTF: national pipe thread fine	
FH: flat head	PFH: phillips flat head	
GA: gauge	PPH: phillips pan head	
HD: heavy-duty	PPHTF: phillips pan head thread forming	
HF: hex flange	PRH: phillips round head	
HH: hex head	PTH: phillips truss head	
HHF: hex head flange	PTO: power-take-off	
HHFTF: hex head flange thread forming	RH: right hand	
HJ: hex jam	ROPS: roll-over protection system	
HLH: hex lag head		

Touch Up Paint

Exmark black touch up spray paint – gloss black.

Exmark red touch up paint (spray paint – P/N 1-850337 - .6 oz liquid bottle – P/N 103-9140).

EXMARK PARTS PLUS

PARTS

OVERNIGHT

OR *FREE**

If your Exmark dealer does not have the Exmark part in stock, Exmark will get the parts to the dealer the next business day or the part will be FREE Guaranteed!! (Some restrictions apply. See your participating Exmark Dealer for details.)

Contents

Complete Deck Assembly	5
Deck Assembly	6
Deck W/Decals Assembly No. 116-1665	7
Deck Idler Assembly No. 116-3755	8
Main Frame Assembly	9
Roll-Over Protection System Assembly No. 116-2882	11
Caster Wheel and Fork Assembly	12
Deck Lift Assembly	13
Height-of-Cut Assembly No. 109-7438	15
Controls Assembly	16
Motion Control Assembly	17
Rear Wheel and Park Brake Assembly	18
Brake Handle Assembly No. 116-1878	19
Seat Assembly	20
Seat W/Tracks Assembly No. 116-4474	21
LP Valve, Tank and Hose Assembly	22
LP Solenoid Regulator Assembly No. 116-2554	23
LP Solenoid Regulator Assembly No. 116-5638	24
Engine Assembly	25
Hydraulic Assembly	26
LH Hydro Assembly No. 116-1326	27
RH Hydro Assembly No. 116-1325	28
Pump Idler Assembly No. 116-1255	29
Electrical Assembly	30

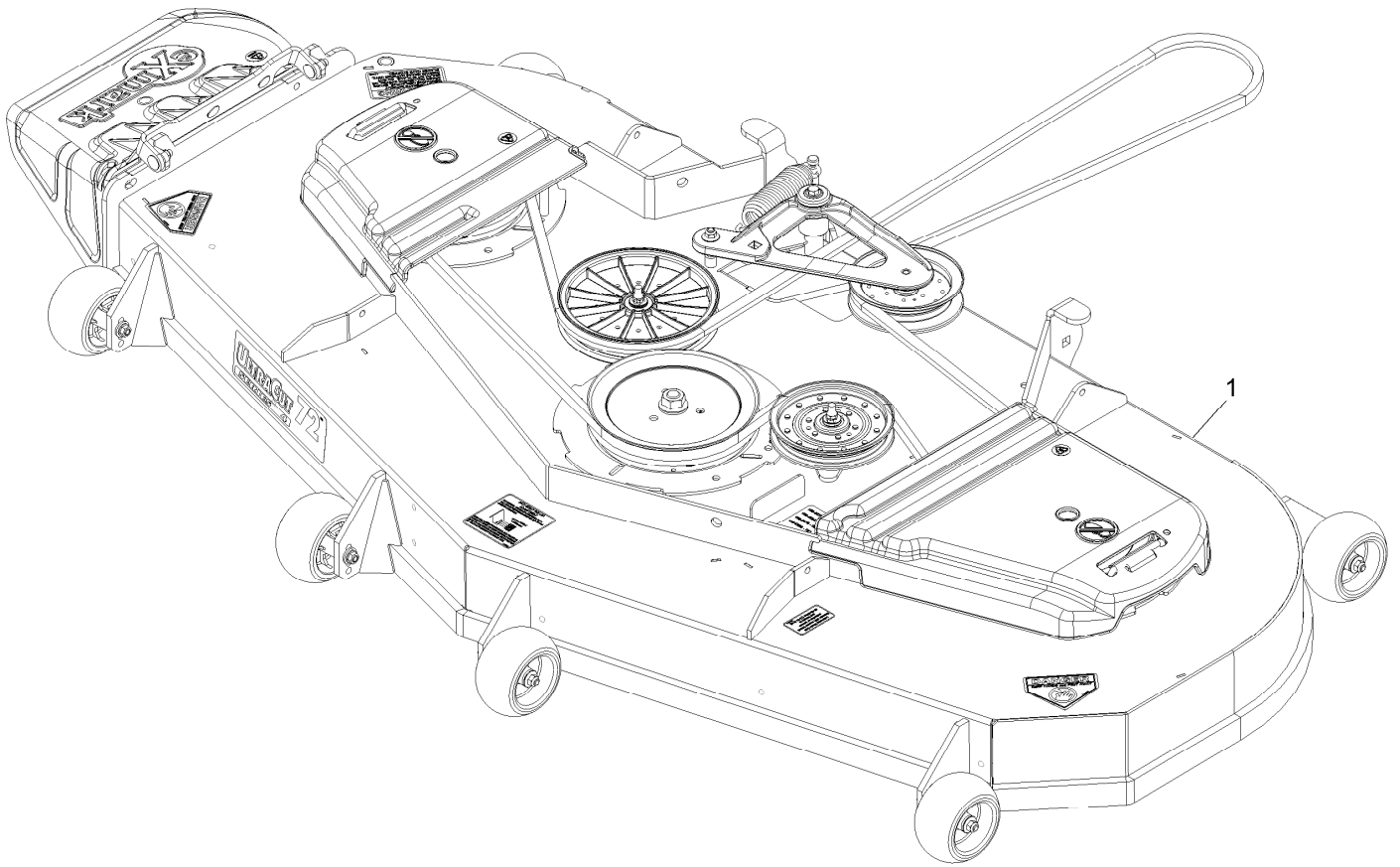

Complete Deck Assembly

<i>Ref.</i>	<i>Part Number</i>	<i>Qty.</i>	<i>Description</i>
1	116-3600	1	ASM,724 Deck Complete

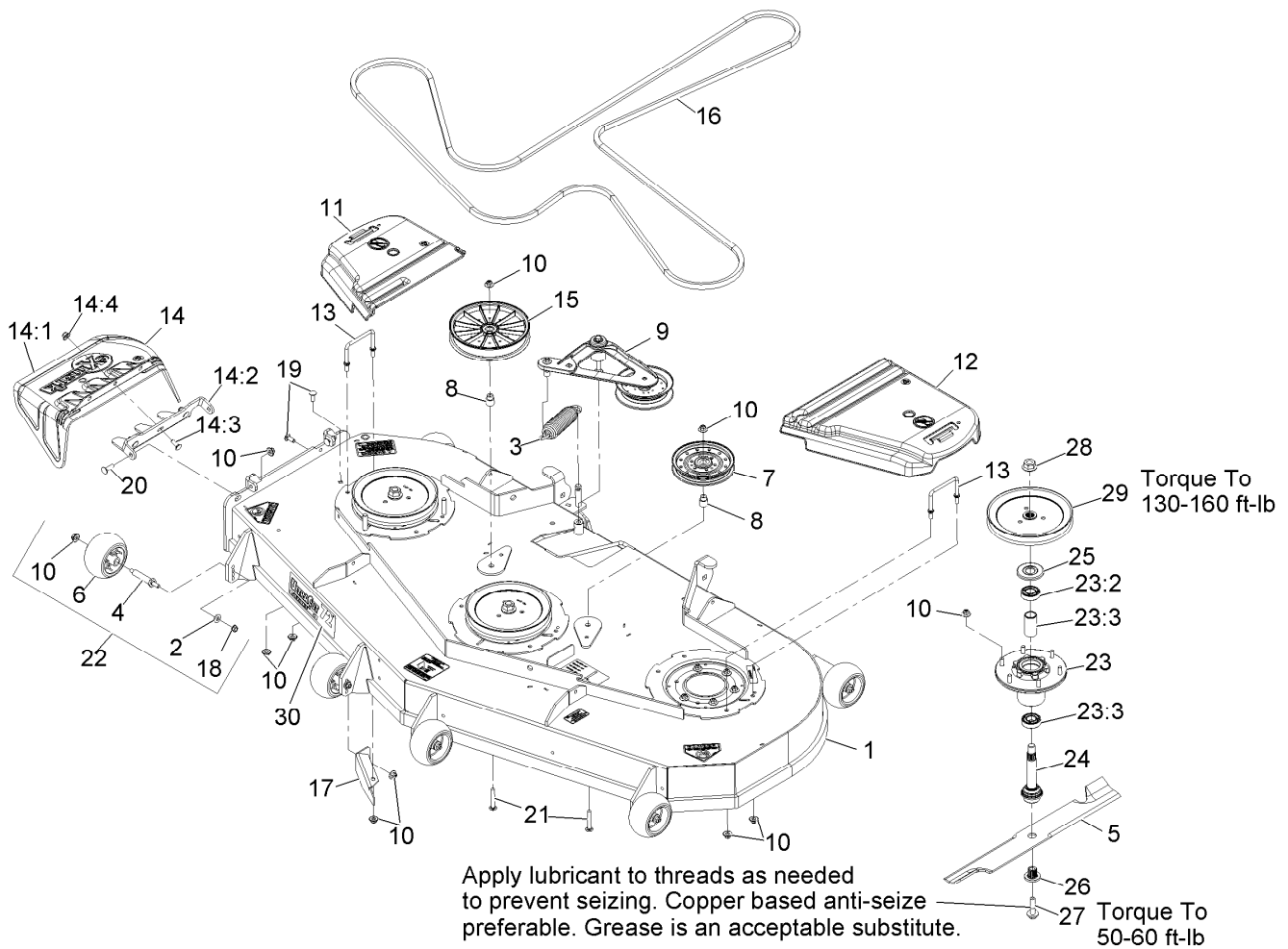

Deck Assembly

Ref.	Part Number	Qty.	Description	Ref.	Part Number	Qty.	Description
1	116-1665	1	ASM,Deck W/Decals 724	14:2	109-8675-01	1	Bracket,Discharge Chute
2	98-5975	6	Washer-Spring Disc 3/8	14:3	3231-22	3	Bolt-Carriage 3/8-16 X 1
3	116-0133	1	Extension-Spring	14:4	109-6658	3	Nut-Nyloc 3/8-16 Flg
4	99-2842	6	Spacer	15	109-0996	1	Pulley,Idler 8"flat
5	103-6404	3	Blade, Notched 24.5 (.94 Hole)	16	109-9023	1	Belt,V-5V X 219.00"
5	103-6399	3	Blade, Extreme 24.5 (.94 Hole)	17	109-9695-01	1	Baffle,Discharge 726
5	103-6394	3	Blade, Mulch 24.5 (.94 Hole) ●	18	3290-357	6	Nut-Whizlock 3/8-16
5	103-6389	3	Blade, Low Lift 24.5 (.94 Hole)	19	3231-22	2	Bolt-Carriage 3/8-16 X 1
5	103-6384	3	Blade, Solid 24.5 (.94 Hole)	20	3231-28	2	Bolt-Carriage 3/8-16 X 1 1/4
6	1-603299	6	Roller-Scalp, Anti	21	3231-44	2	Bolt-Carriage 3/8-16 X 2 1/2
7	1-633109	1	Idler-Flat	22	103-4051	6	Kit,Anti-Scalp Roller
8	1-633456	2	Bushing,Idler	23	116-3344	3	ASM-Cutter Hsg With Bearings
9	116-3755	1	Deck Idler ASM	23:2	116-0720	2	Bearing-Ball
10	109-6658	34	Nut-Nyloc 3/8-16 Flg	23:3	116-3312	1	Spacer-Bearing
11	116-0094	1	Cover-Belt, RH	24	116-3341	3	ASM-Spindle And Seal
12	109-6938	1	Cover-Belt, LH	25	116-1286	3	Guard,Bearing Top .989
13	109-6982	2	Wireform-Cover	26	103-3037	3	Bushing,Splined
14	109-7188	1	ASM,Discharge Chute	27	109-9220	3	Screw-Sems 1/2-20 X 2.19
14:1	109-2738	1	Chute,Discharge	28	104-0753	3	Nut-Hex 3/4-16 Flg Special
				29	116-1377	3	Sheave,Blade Drive 8.74
				30	116-0944	1	Decal,Ultracut 72 Series 4

● Requires installation of mulch kit for proper mulching. See your Exmark dealer for details.

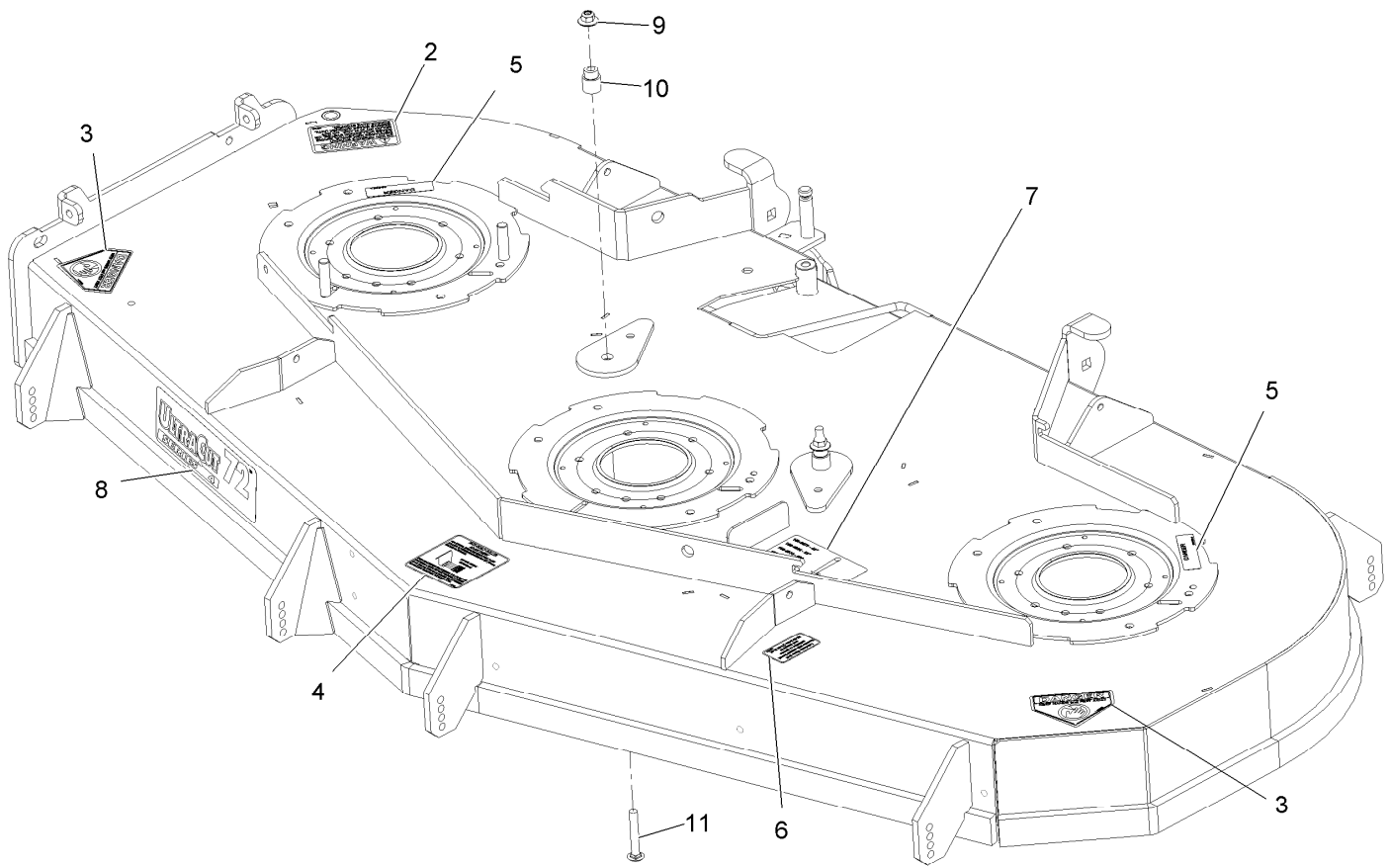

Deck W/Decals Assembly No. 116-1665

<i>Ref.</i>	<i>Part Number</i>	<i>Qty.</i>	<i>Description</i>
2	1-303508	1	Decal-Warning, Discharge
3	1-403005	2	Decal-Danger
4	1-633922	1	Decal,Antiscalp
5	98-5954	2	Decal-Cover, Missing
6	109-3148	1	Decal,Bolt Torque
7	109-9361	1	Decal,Belt Routing
8	116-0944	1	Decal,Ultracut 72 Series 4
9	109-6658	2	Nut-Nyloc 3/8-16 Flg
10	1-633456	2	Bushing,Idler
11	3231-44	2	Bolt-Carriage 3/8-16 X 2 1/2

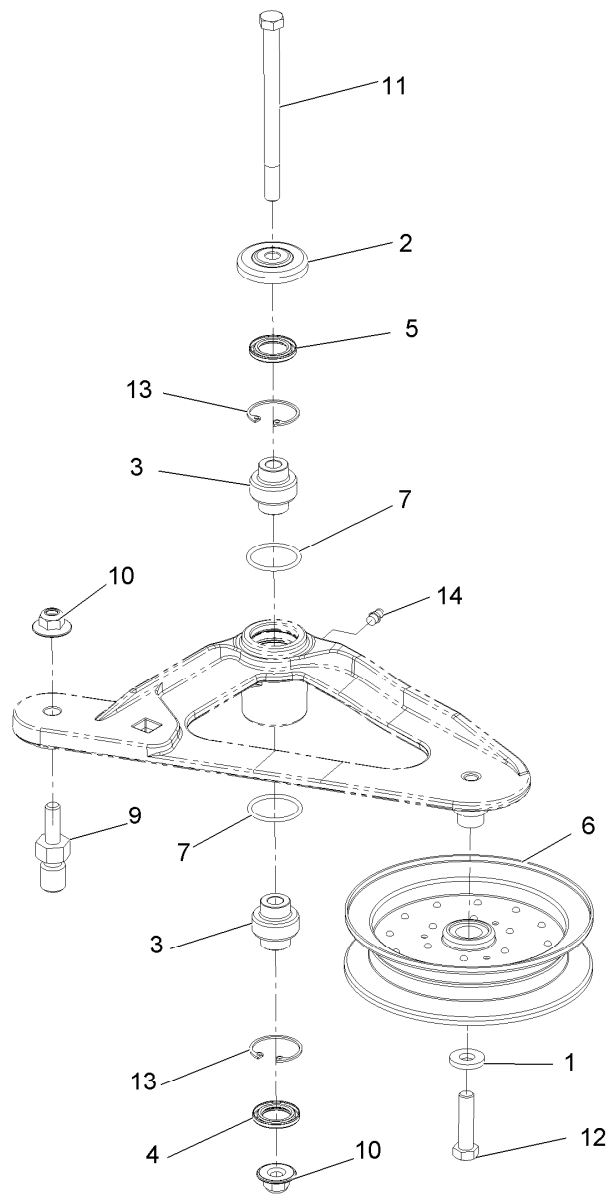

Deck Idler Assembly No. 116-3755

<i>Ref.</i>	<i>Part Number</i>	<i>Qty.</i>	<i>Description</i>
1	43-0940	1	Spacer
2	103-2916	1	Guard-Top
3	103-3504	2	Bearing-Spherical
4	103-3505	1	Seal-Double Lip
5	103-3506	1	Seal-Single Lip
6	103-8743	1	Pulley-Idler, Flanged
7	106-7159	2	O-Ring
9	116-3467	1	Pin-Spring, Anchor
10	109-6658	2	Nut-Nyloc 3/8-16 Flg
11	109-7409	1	Screw-Shoulder 3/8-16 X 5
12	323-8	1	Screw-HH 3/8-16 X 1 1/2
13	32120-10	2	Ring-Retaining
14	302-19	1	Zerk-1/4-28 Str

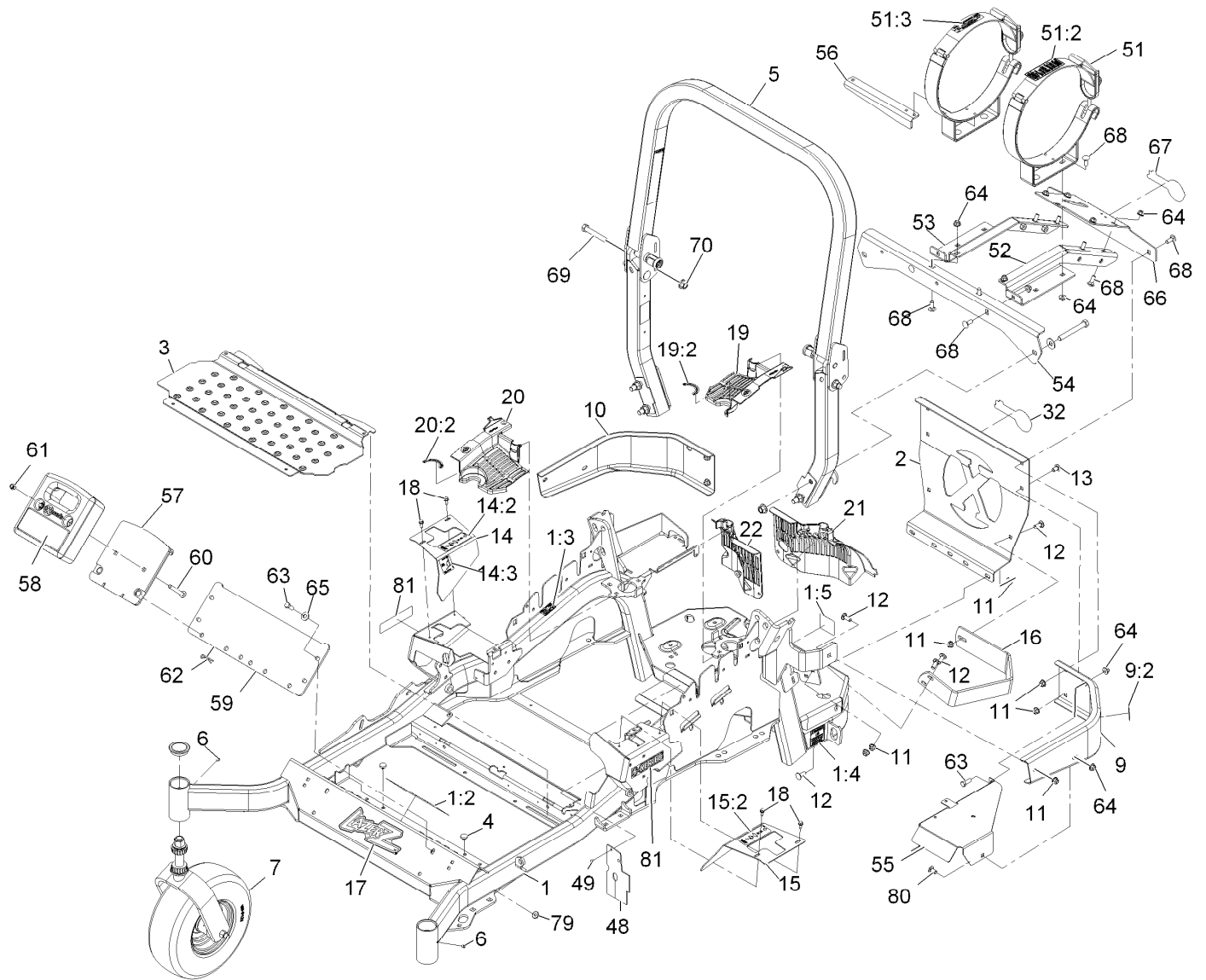

Main Frame Assembly

Ref.	Part Number	Qty.	Description	Ref.	Part Number	Qty.	Description
1	116-2126	1	Main Frame ASM	14:2	109-7232	1	Decal-Motion Control
1:2	116-3303	1	Decal-Slope	14:3	109-7929	1	Decal-Park Brake
1:3	103-2076	2	Decal-Caution	15	116-0580	1	LH Motion Control Cover ASM
1:4	116-0205	2	Decal-Belt Drive	15:2	109-7232	1	Decal-Motion Control
1:5	116-4858	1	Decal-Spark Arrester	16	116-0043-03	1	Guard-Muffler
2	109-8863-03	1	Plate,Rear Guard	17	103-3113	1	Decal,Lazer Model
3	116-0024-01	1	Floorpan	18	32144-10	4	Screw-HWH 1/4-20 X .62
4	1-513658	2	Bumper	19	116-0170	1	LH Hydro Guard ASM
5	116-2882	1	ROPS ASM	19:2	116-0157	1	Decal-Hydro Oil
6	1-811010	2	Plug	20	116-0171	1	RH Hydro Guard ASM
7		2	ASM,Front Caster W/Fork ●	20:2	116-0157	1	Decal-Hydro Oil
9	116-0180	1	LH Bumper ASM	21	109-9057	1	Guard-Hydro, Rear LH
9:2	103-2076	1	Decal-Caution	22	109-9058	1	Guard-Hydro, Rear RH
10	116-0057-03	1	Bumper-RH	32	103-2883	1	Decal,Exmark Logo
11	104-8301	11	Nut-Nyloc 3/8-16 Flg	48	116-2362	1	Deflector, Air Flow
12	3231-22	7	Bolt-Carriage 3/8-16 X 1	49	1-803035	2	Rivet 3/16 X 1/4
13	3231-21	4	Bolt-Carriage 3/8-16 X 3/4	51	116-2817	1	Tank Bracket W/Decals
14	116-0579	1	RH Motion Control Cover ASM	51:2	109-9875	1	Decal,Lpg Warning

● Not serviced separately

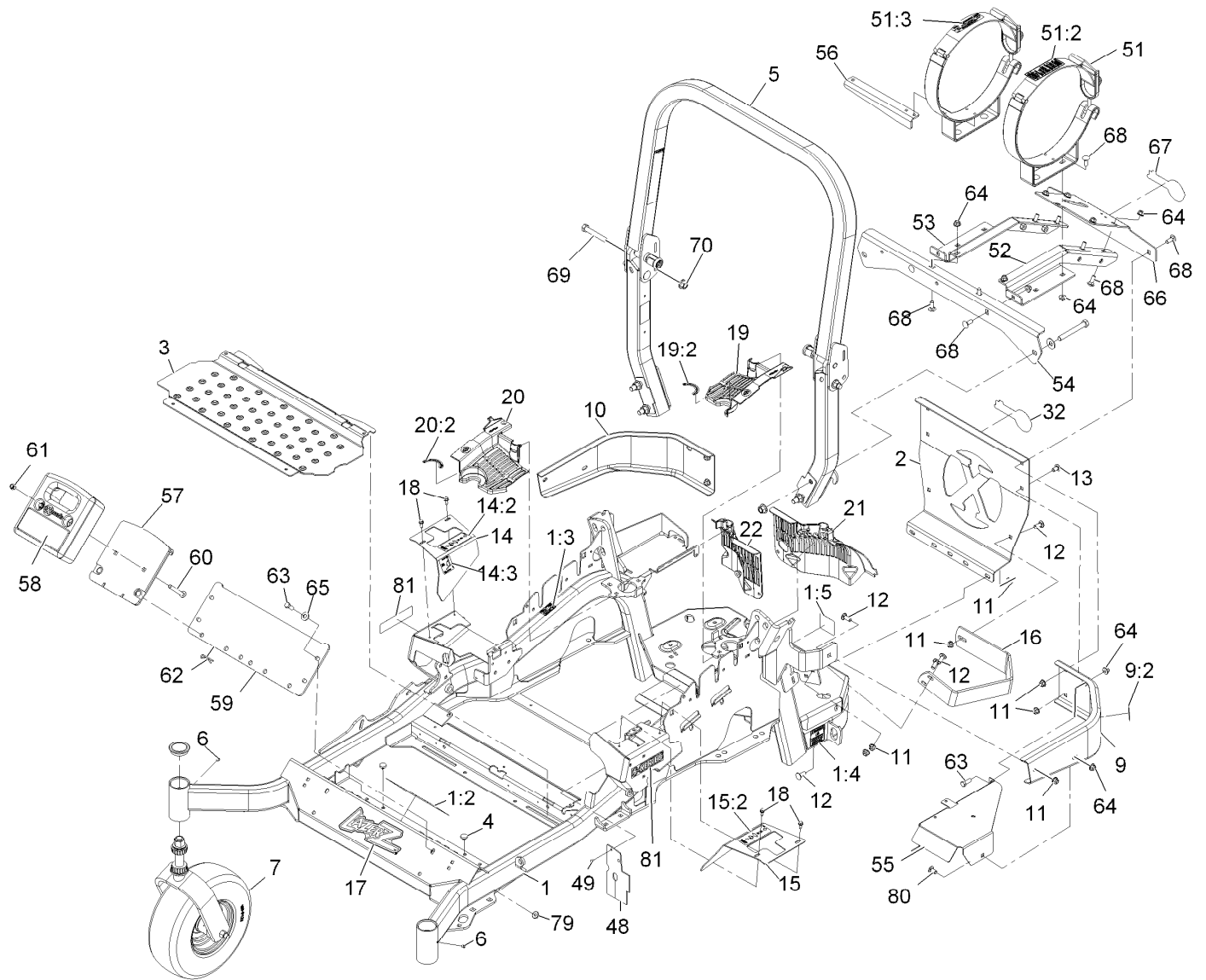

Main Frame Assembly (continued)

Ref.	Part Number	Qty.	Description	Ref.	Part Number	Qty.	Description
51:3	116-1714	1	Decal,Lpg 43.5Lb Tank	63	323-6	5	Screw-HH 3/8-16 X 1
52	116-2819-03	1	LH Lpg Frame ASM	64	104-8301	14	Nut-Nyloc 3/8-16 Flg
53	116-2820-03	1	RH Lpg Frame ASM	65	98-5975	4	Washer-Spring Disc 3/8
54	116-2285-03	1	Support-Lpg Frame, Front	66	116-2553-03	1	Support-Rear Frame, Lpg
55	116-4017-03	1	Panel-LP, Ac	67	103-2883	1	Decal,Exmark Logo
56	116-2301-03	1	Plate-Index , Lpg Tank	68	3231-2	14	Bolt-Carriage 3/8-16 X 1
57	103-6364-01	2	Wld,Weight Mount	69	325-13	1	Screw-HH 1/2-13 X 3 1/4
58	103-6367-01	2	Weight,Cast 36Lb	70	99-5107	1	Nut-Lock 1/2-13
59	103-6368-01	1	Plate,Weight ASM Mount	79	104-8301	4	Nut-Nyloc 3/8-16 Flg
60	3231-10	4	Bolt-Carriage 3/8-16 X 3	80	3231-21	1	Bolt-Carriage 3/8-16 X 3/4
61	3296-39	4	Nut-Nyloc 3/8-16	81	116-3884	2	Decal-S-Series
62	9335124	4	Hairpin-Cotter				

● Not serviced separately

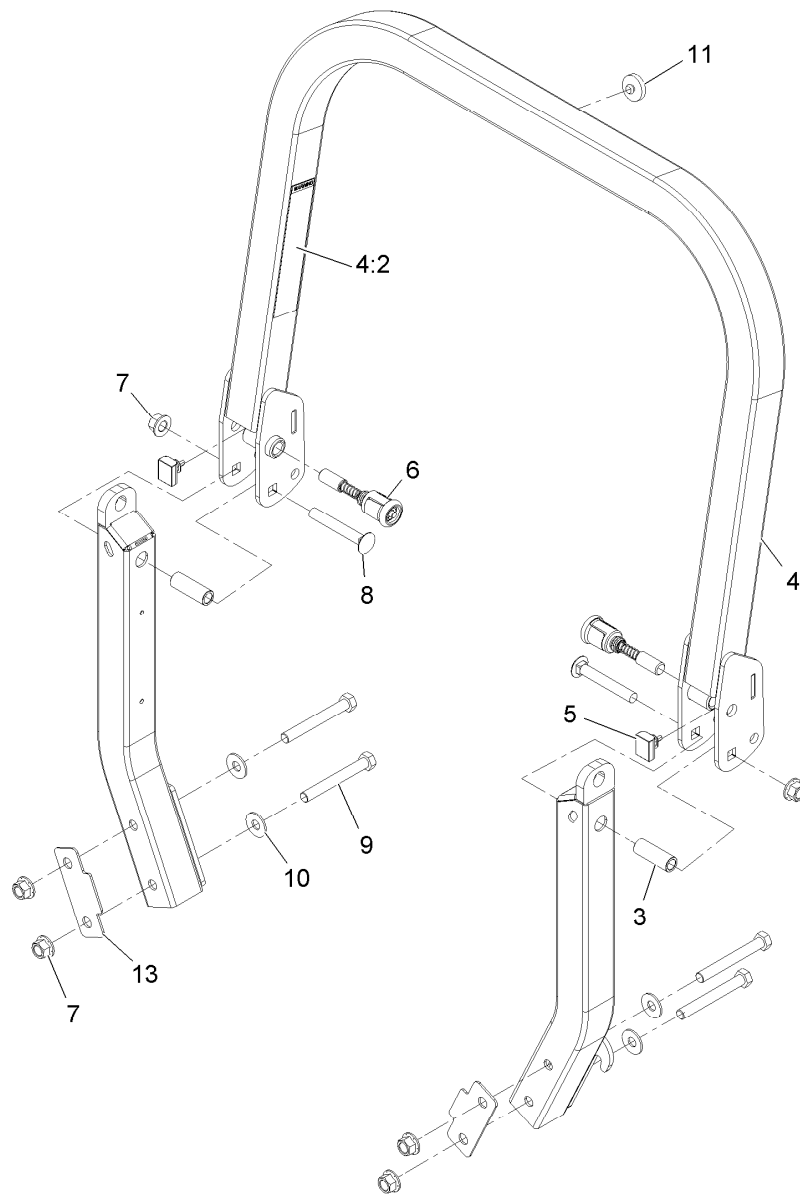

Roll-Over Protection System Assembly No. 116-2882

<i>Ref.</i>	<i>Part Number</i>	<i>Qty.</i>	<i>Description</i>
3	109-6653	2	Spacer
4	116-0019	1	Upper ROPS ASM
4:2	107-2102	1	Decal-Warning, Folding ROPS
5	109-5337	2	Bumper-ROPS
6	116-0104	2	Spring Pin ASM
7	99-5107	6	Nut-Lock 1/2-13
8	3233-10	2	Bolt-Carriage 1/2-13 X 3 1/2
9	325-17	4	Screw-HH 1/2-13 X 4
10	109-9505	4	Washer-Spring
11	109-9233	1	Bumper-Push-In, Rubber
13	116-0960	2	Spacer

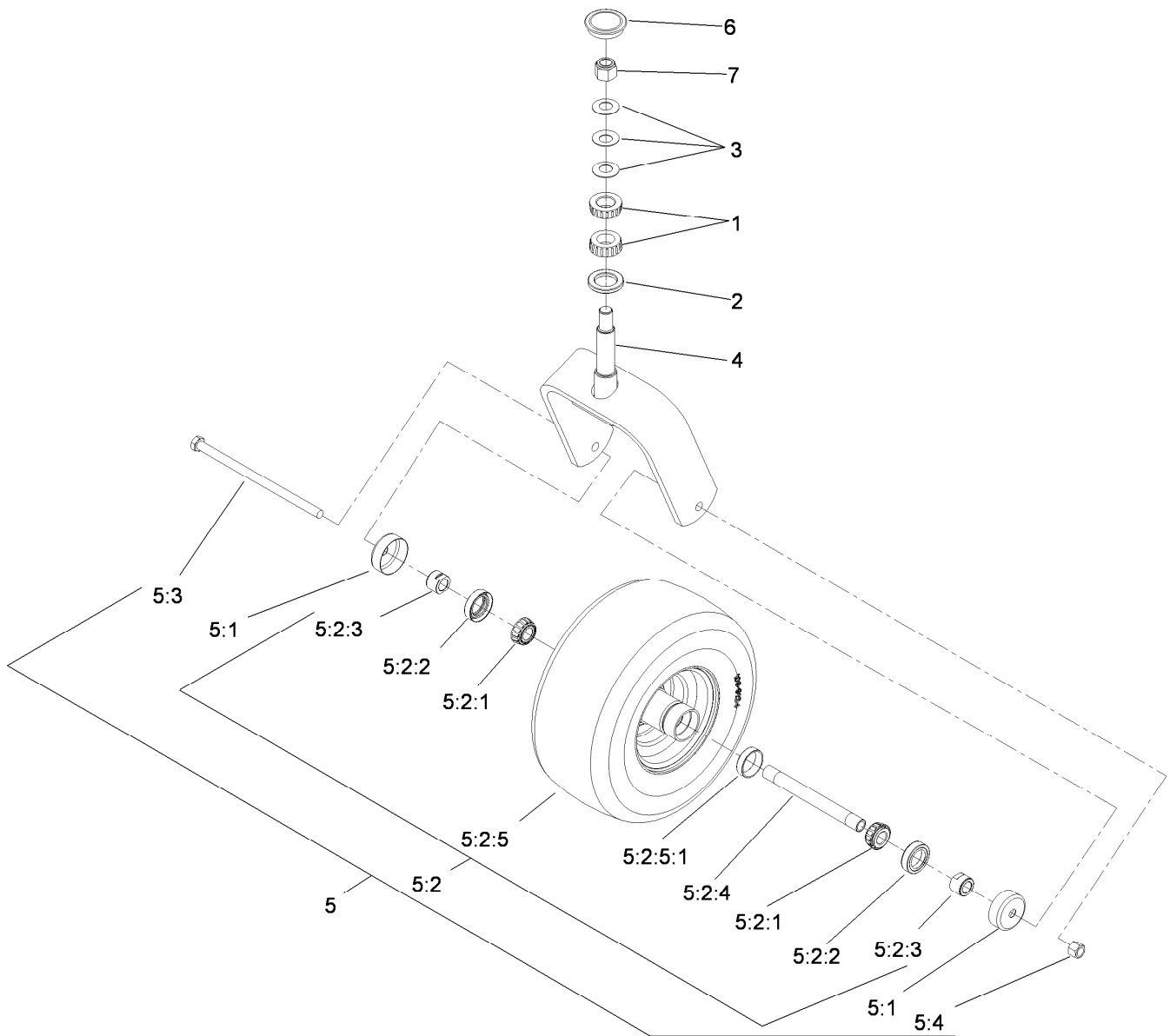

Caster Wheel and Fork Assembly

Ref.	Part Number	Qty.	Description
1	1-543509	2	Bearing-Roller, Tapered
2	1-543511	1	Seal-Grease
3	1-633508	3	Washer-Bellville
4	103-1474-01	1	Caster-Fork
5	109-9127	1	Wheel And Tire ASM
5:1	103-2768	2	Guard-Seal
5:2		1	Wheel And Tire ASM ●
5:2:1	1-633585	2	Bearing-Cone, Taper
5:2:2	103-0063	2	Seal-Caster

Ref.	Part Number	Qty.	Description
5:2:3	103-3051	2	Spacer-Nut ■
5:2:4	103-5156	1	Axle-Caster
5:2:5	109-9124	1	Wheel And Tire ASM
5:2:5:1	1-633584	1	Bearing-Cup
5:3	325-39	1	Screw-HH
5:4	3296-23	1	Nut-Lock, NI
6	103-4882	1	Cap-Grease
7	3296-51	1	Nut-Lock, NI

● Not serviced separately

■ Use Pro-Lock, Nut Type (P/N 1-840022, .5ml tube) on threads.

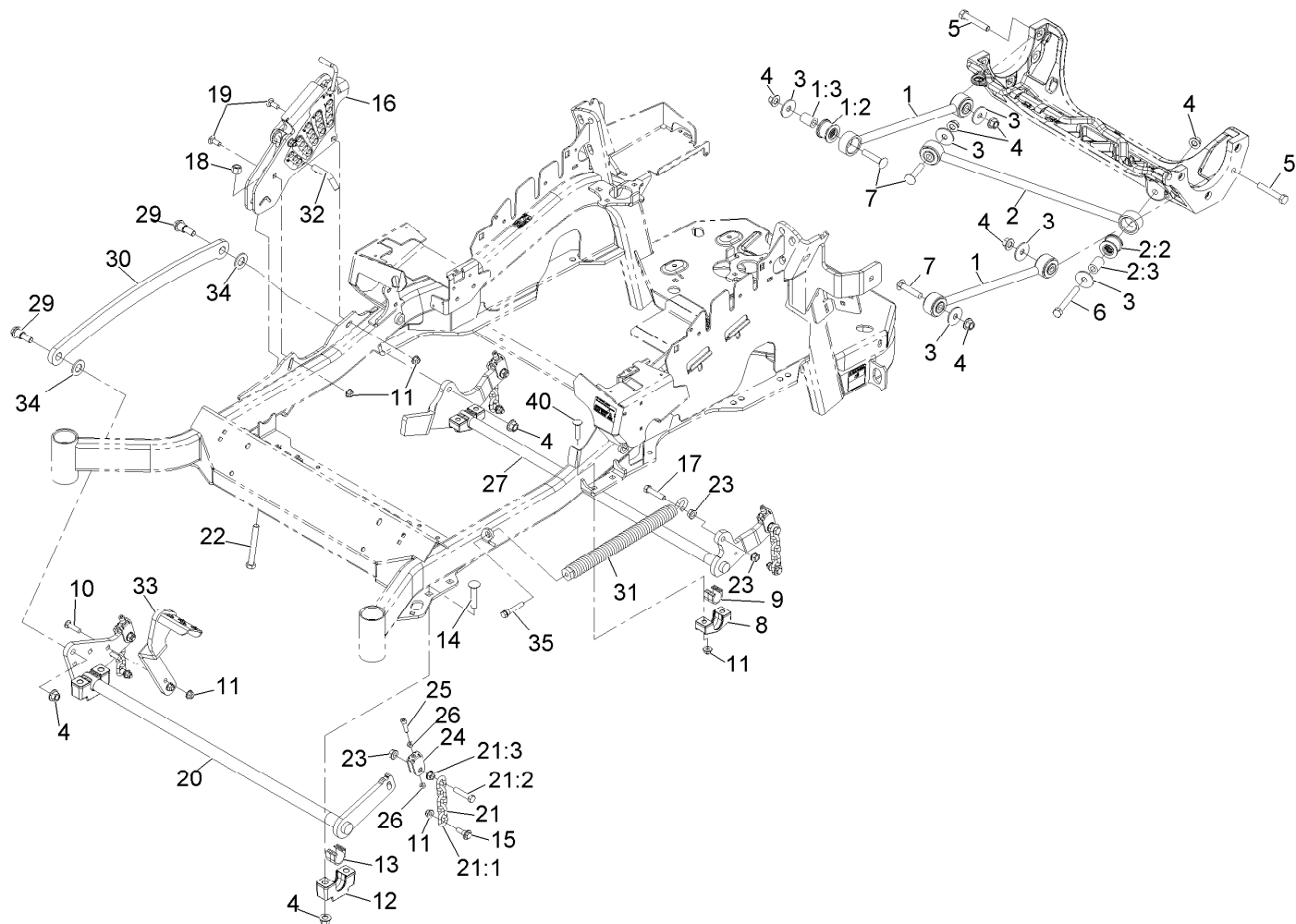

Deck Lift Assembly

Ref.	Part Number	Qty.	Description	Ref.	Part Number	Qty.	Description
1	109-7952	2	Deck Strut ASM	14	116-1700	4	Bolt-Carriage 1/2-13 X 2 1/2 Spl Neck
1:2	109-5009	2	Bushing-Suspension, Rubber	15	109-9840	4	Screw-Hex Flange 3/8-16 X .80
1:3	109-5010	2	Spacer	16	109-7438	1	Height-Of-Cut ASM
2	109-5013	1	Panhard Rod ASM	17	109-9065	1	Screw-HH 7/16-14 X 2
2:2	109-5009	2	Bushing-Suspension, Rubber	18	3296-23	1	Nut-Nyloc 1/2-13
2:3	109-5010	2	Spacer	19	3231-2	2	Bolt-Carriage 3/8-16 X 1
3	86-1990	6	Washer	20	116-2217-03	1	Cross Shaft Front ASM
4	99-5107	12	Nut-Lock 1/2-13	21	116-0756	4	Deck Lift Chain ASM
5	325-12	2	Screw-HH 1/2-13 X 3	21:1	1-633447	1	Chain-Lift, Deck
6	325-17	1	Screw-HH 1/2-13 X 4	21:2	109-9065	1	Screw-HH 7/16-14 X 2
7	3233-34	3	Bolt-Carriage 1/2-13 X 2 1/2	21:3	32128-37	1	Nut-Whizlock 7/16-14
8	116-0818-03	2	Support-Bearing, Cross Shaft Rear	22	116-0559	1	Bolt-HH 1/2-13 X 4 Tap
9	109-7173	2	Bearing-Cross, Rear Shaft	23	32128-37	6	Nut-Whizlock 7/16-14
10	3231-4	2	Bolt-Carriage 3/8-16 X 1 1/2	24	109-9066	4	Yoke-Adjust, Deck
11	104-8301	12	Nut-Nyloc 3/8-16 Flg	25	3274-18	4	Screw-Sh 5/16-18 X 1 1/4
12	109-9409	2	Support-Cross Shaft, Bearing Front	26	3218-2	8	Nut-Jam 5/16-18
13	109-9410	2	Bearing-Shaft Front, Cross	27	116-0459-03	1	Lift-Deck, Rear
				29	116-0780	2	Screw-Shoulder HHF 1/2-13 X 1.12

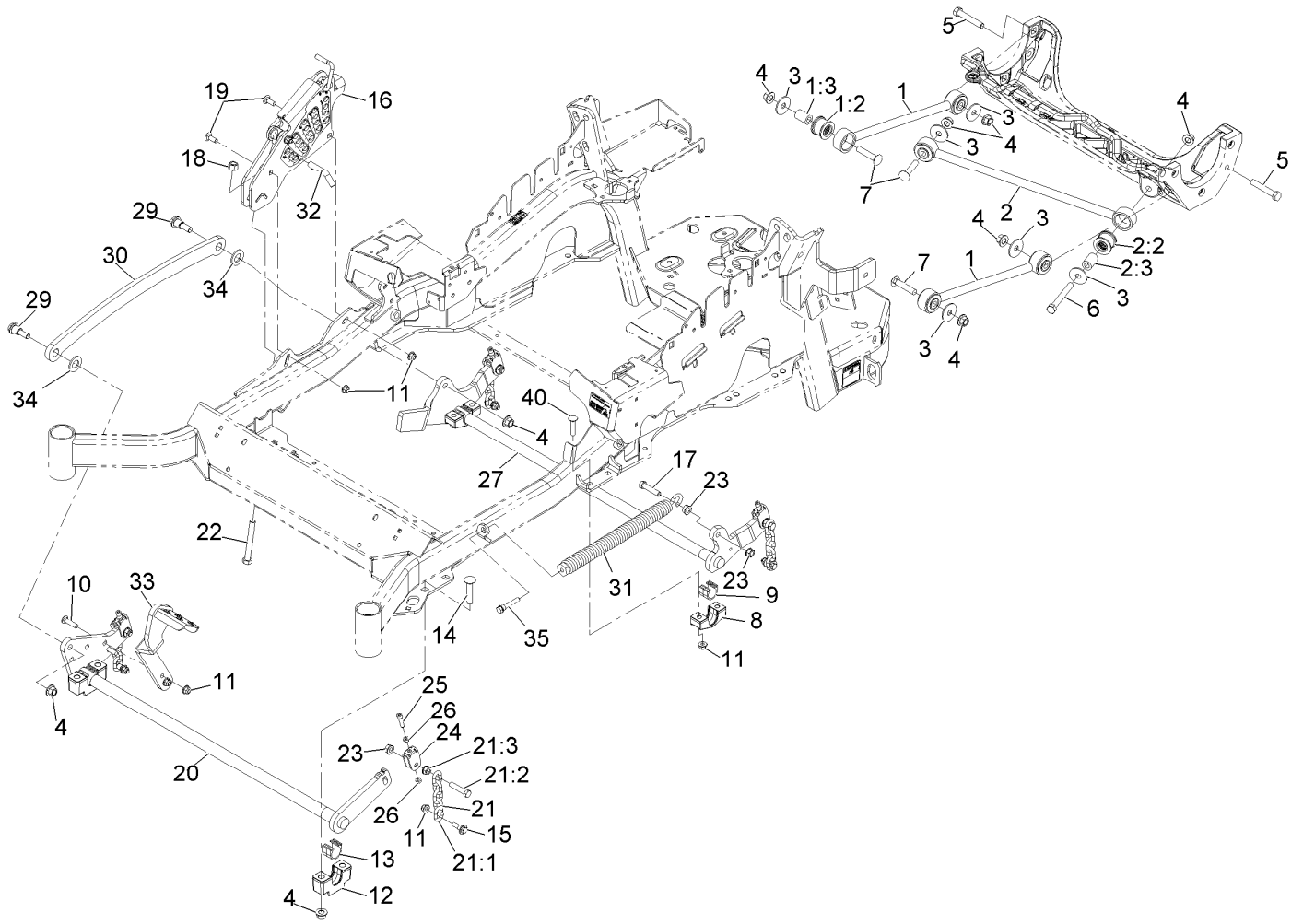

Deck Lift Assembly (continued)

<i>Ref.</i>	<i>Part Number</i>	<i>Qty.</i>	<i>Description</i>	<i>Ref.</i>	<i>Part Number</i>	<i>Qty.</i>	<i>Description</i>
30	116-0797-03	1	Link-Lift, Deck	34	3256-28	2	Washer-3/4 Sae
31	116-0000	1	Extension Spring ASM	35	92-7674	1	Screw-Shcs 3/8-16 X 2.212
32	109-8757	1	Pin-HOC	40	3231-5	4	Bolt-Carriage 3/8-16 X 1 3/4
33	116-1919-01	1	Lever-Foot				

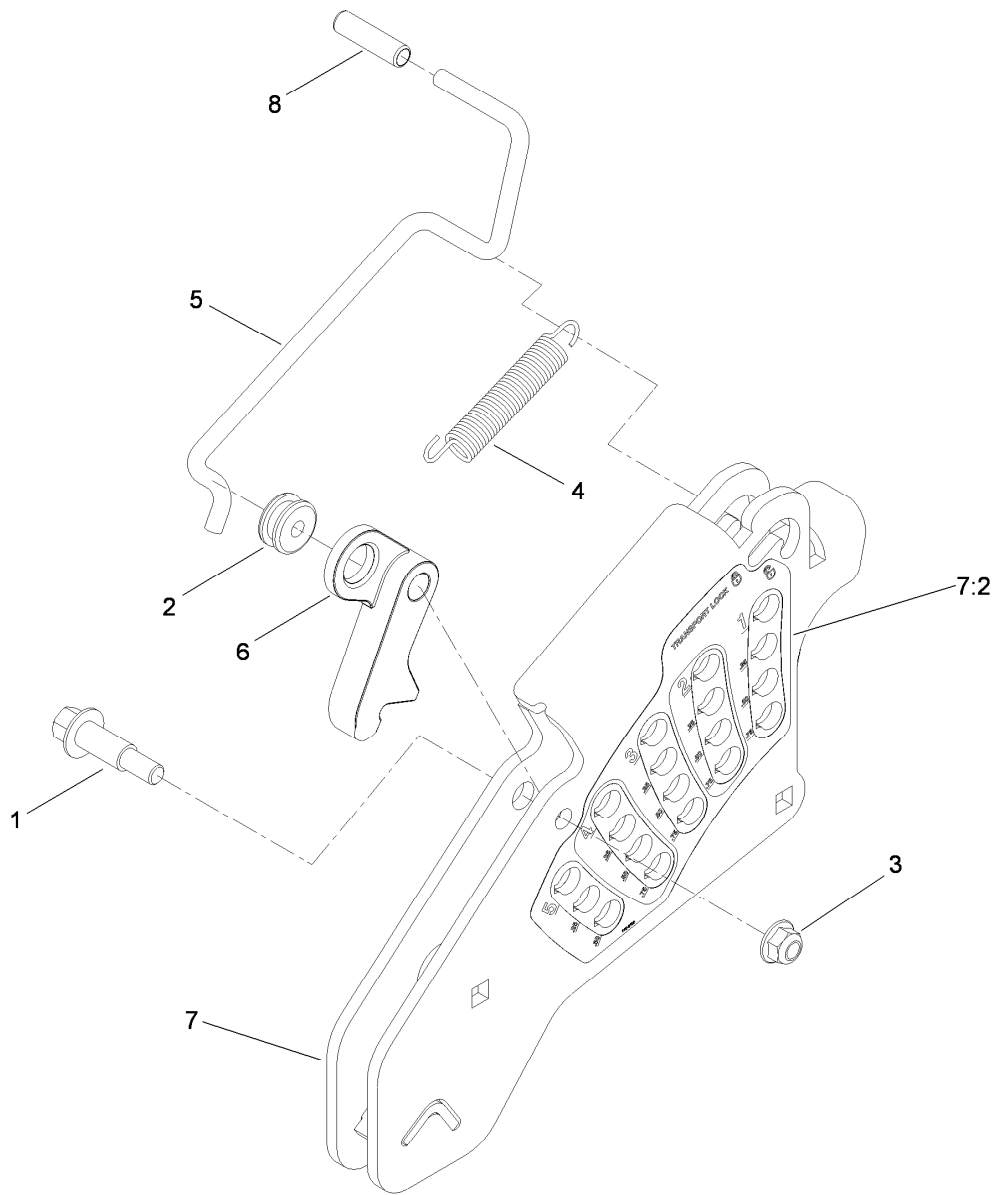

Height-of-Cut Assembly No. 109-7438

<i>Ref.</i>	<i>Part Number</i>	<i>Qty.</i>	<i>Description</i>
1	62-1330	1	Bolt-Shoulder
2	109-7130	1	Grommet
3	104-8301	1	Nut-Flange, NI
4	109-7124	1	Spring-Extension
5	109-7128	1	Rod-Lock, Transport
6	116-0118	1	Pawl-Transport, HOC
7	109-7335	1	HOC Plate ASM
7:2	116-0752	1	Decal-HOC
8	109-8250	1	Grip-Lever

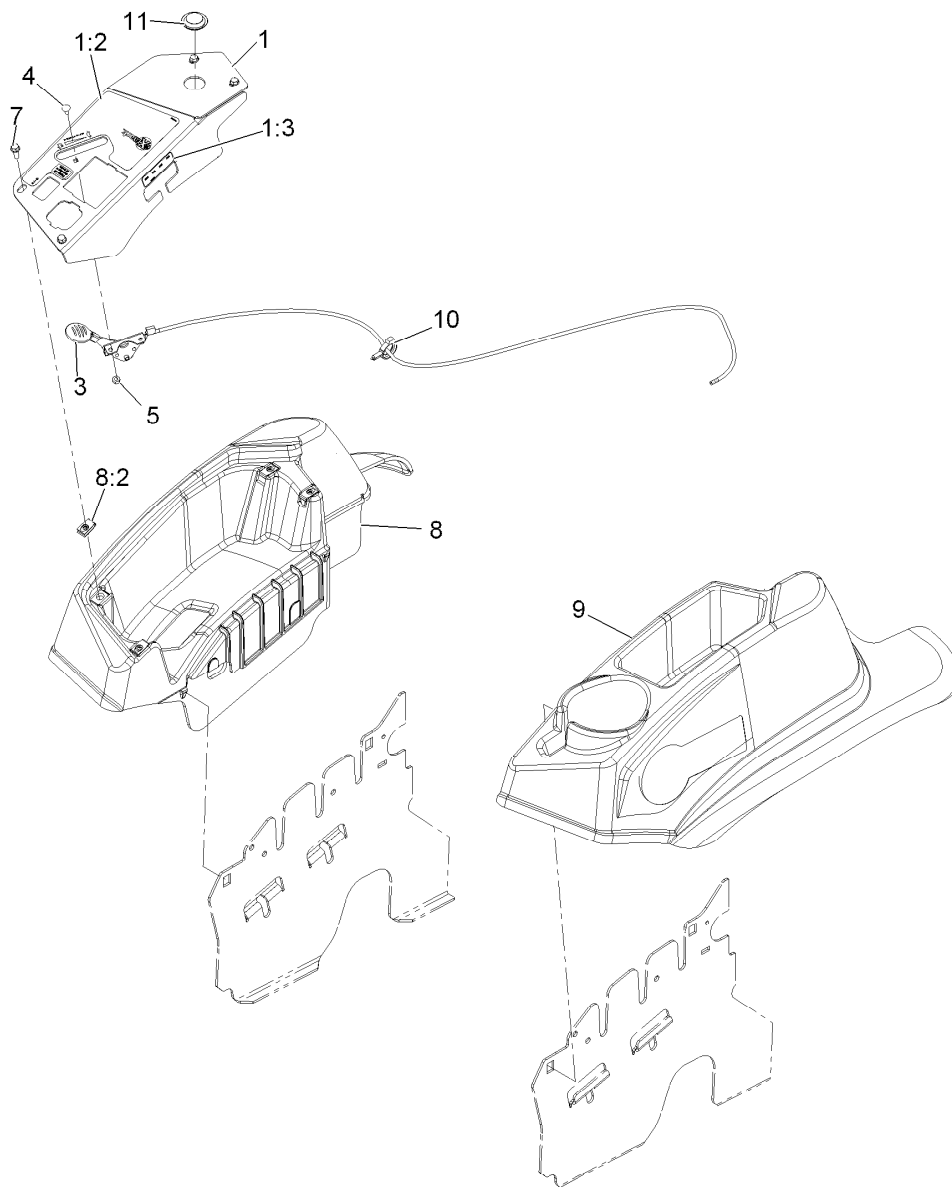

Controls Assembly

Ref.	Part Number	Qty.	Description
1	116-3262	1	Control Panel W/Decals ASM
1:2	116-3261	1	Decal,Control Panel LP
1:3	109-7330	1	Decal-Fuse
3	116-1972	1	ASM,Throttle Cable
4	1-807513	2	Bolt-Carriage #10-24 X 1/2
5	3296-2	2	Nut-Nyloc #10-24
7	32105-15	4	Screw-Machine 1/4-20 X 3/4
8	116-1278	1	Console,RH As ASM
8:2	107069	4	Nut-Retainer-Panel 1/4-20
9	109-9457	1	Console, LH As
10	105-1853	1	Clamp-Hose
11	116-1875	1	Plug,Plastic

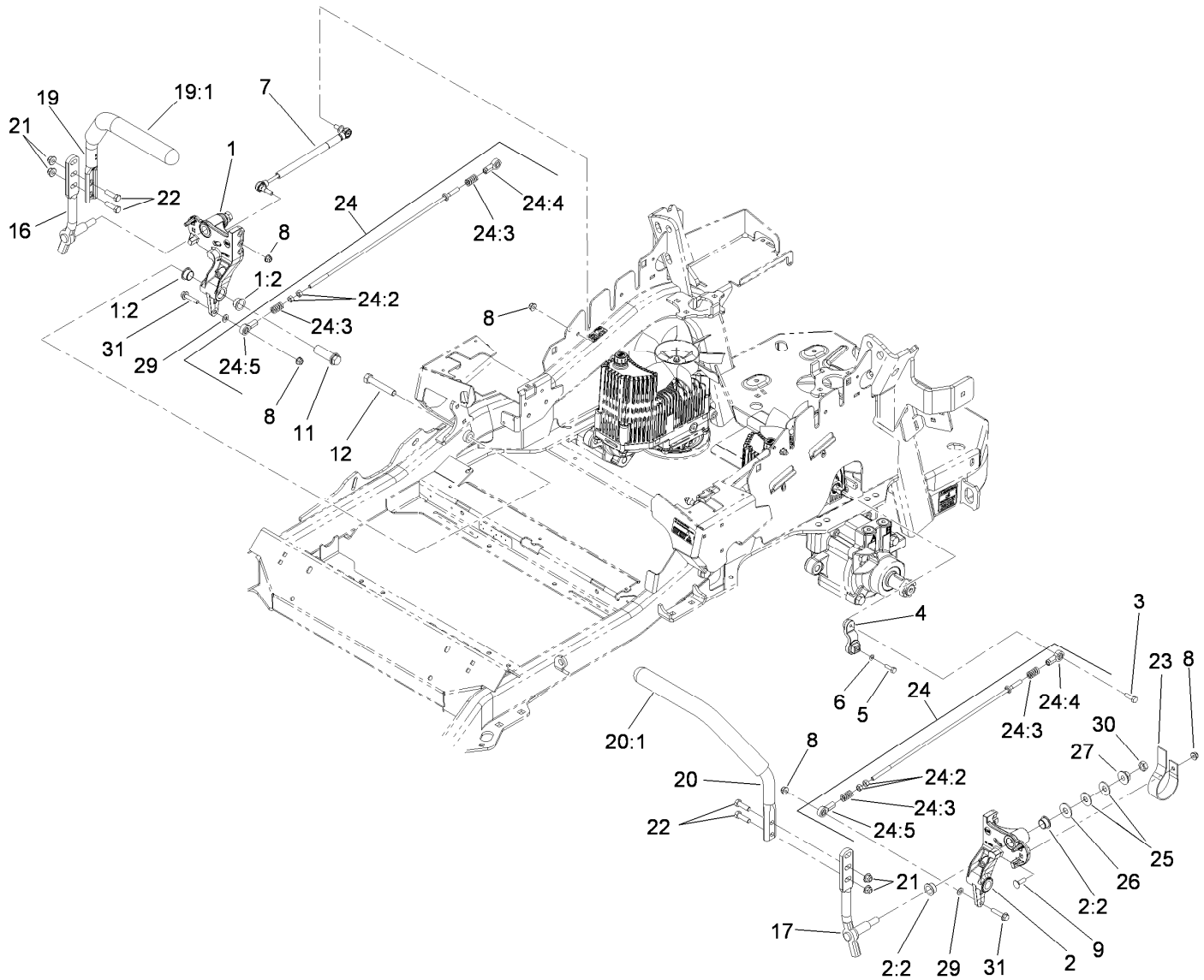

Motion Control Assembly

Ref.	Part Number	Qty.	Description	Ref.	Part Number	Qty.	Description
1	116-0880	1	RH Motion Control And Bushing ASM	19:1	109-5668	1	Grip,Control Lever
1:2	109-8054	4	Bushing-Flanged	20	109-6590	1	ASM,Steering Handle LH
2	116-0881	1	LH Motion Control And Bushing ASM	20:1	109-5668	1	Grip,Control Lever
2:2	109-8054	4	Bushing-Flanged	21	104-8301	4	Nut-Nyloc 3/8-16 Flg
3	116-0648	2	Screw-HH 5/16-18 X 1 W/Patch ●	22	323-7	4	Screw-HH 3/8-16 X 1 1/4
4	109-4581	2	Arm-Control, Pump	23	109-5575	2	Spring-Leaf
5	9080046	2	Screw-HH 1/4-20 X 7/8 ●	24	109-8106	2	Front Pump Linkage ASM
6	1-303435	2	Washer-Spring Disc 1/4	24:2	3219-2	2	Nut-Hex 5/16-24
7	116-0027	2	Damper-Control, Motion	24:3	1-323245	2	Spring-Compression
8	104-8300	8	Nut-Nyloc 5/16-18 Flg	24:4	1-633152	1	Balljoint
9	3230-2	2	Bolt-Carriage 5/16-18 X 1	24:5	1-543017	1	Balljoint
11	109-5891	2	Hub-Threaded	25	109-9505	4	Washer-Spring
12	325-12	2	Screw-HH 1/2-13 X 3	26	3256-6	2	Washer
16	116-0039	1	Lever-Control Motion, RH	27	32128-56	2	Nut-Hex 1/2-13 Flange
17	116-0040	1	Lever-Control Motion, LH	29	3256-23	2	Washer-5/16 Sae
19	109-6589	1	ASM,Steering Handle RH	30	3218-5	2	Nut-Jam 1/2-13
				31	115-1794	2	Screw-Hex Flange 5/16-18 X 1 1/2

● Use Pro-Lock, Nut Type (P/N 1-840022, .5ml tube) on threads.

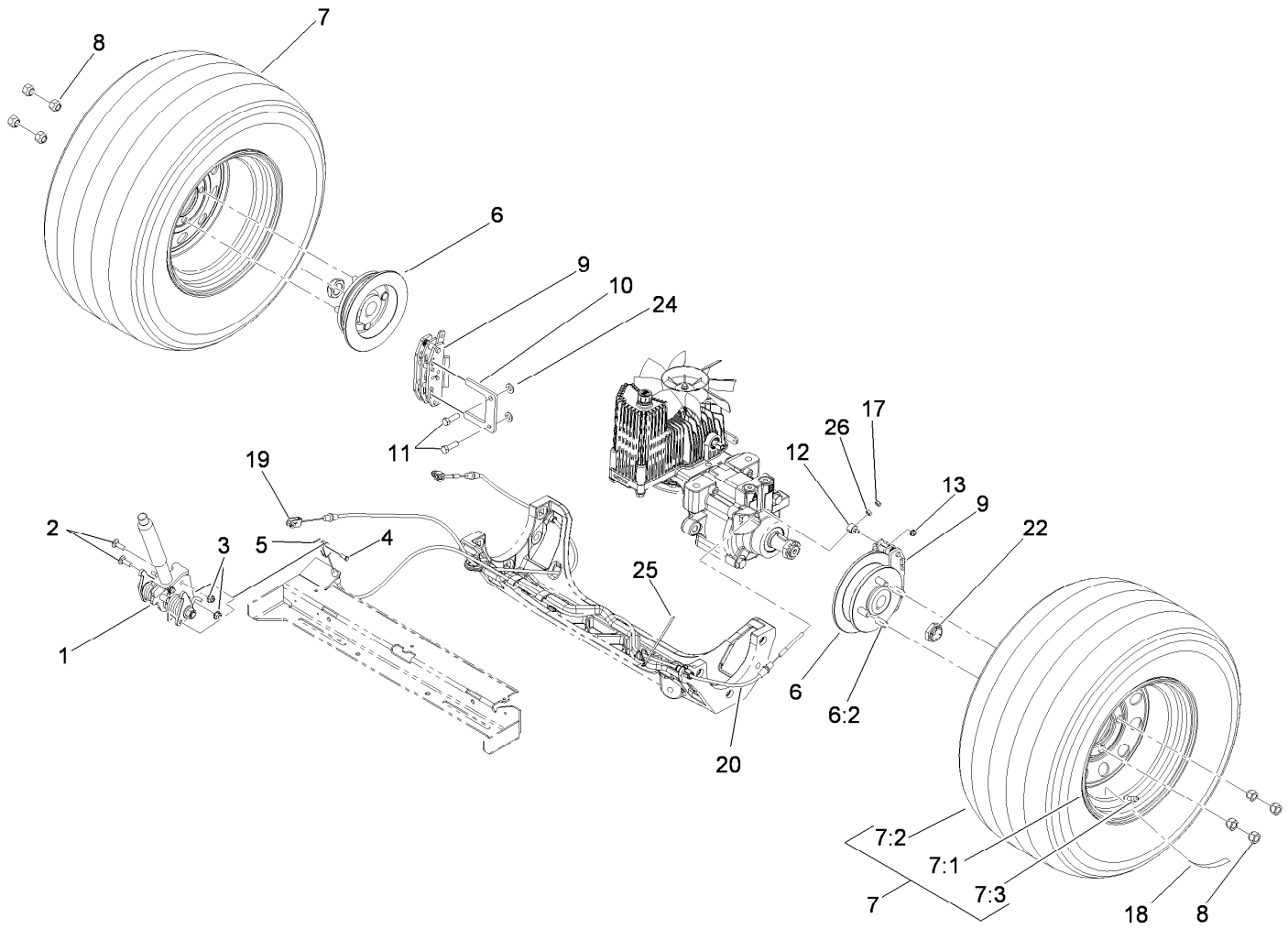

Rear Wheel and Park Brake Assembly

Ref.	Part Number	Qty.	Description	Ref.	Part Number	Qty.	Description
1	116-1878	1	Brake Handle ASM	10	109-0958	2	Plate-Mount, Brake
2	3230-2	2	Bolt-Carriage 5/16-18 X 1	11	92-5727	4	Screw-HH 3/8-16 X 1 1/4 Patch Lock
3	104-8300	2	Nut-Nyloc 5/16-18 Flg	12	112-8379	2	Swivel
4	60-1730	2	Pin-Clevis	13	104-7201	2	Nut-Nyloc 1/4-20 Flg
5	3272-1	2	Pin-Cotter 1/16 X 1/2	17	3296-13	2	Nut-Nyloc 1/4-28
6	116-1746	2	Wheel Hub ASM	18	116-2643	2	Decal-Wheel Nut Torque
6:2	116-1696	4	Stud-Wheel	19	115-3584	1	Cable
7	109-8972	2	Wheel And Tire ASM	20	115-3585	1	Cable
7:1	1-633993	1	Tire	22	116-1399	2	Locknut
7:2	109-3156	1	Rim ASM	24	3256-24	4	Washer-3/8 Sae
7:3	232-27	1	Stem-Valve	25	116-0940	1	Tie-Cable
8	242-50	8	Nut-Lug 1/2-20	26	3219-1	2	Nut-Hex 1/4-28
9	109-2889	2	Caliper-Brake				

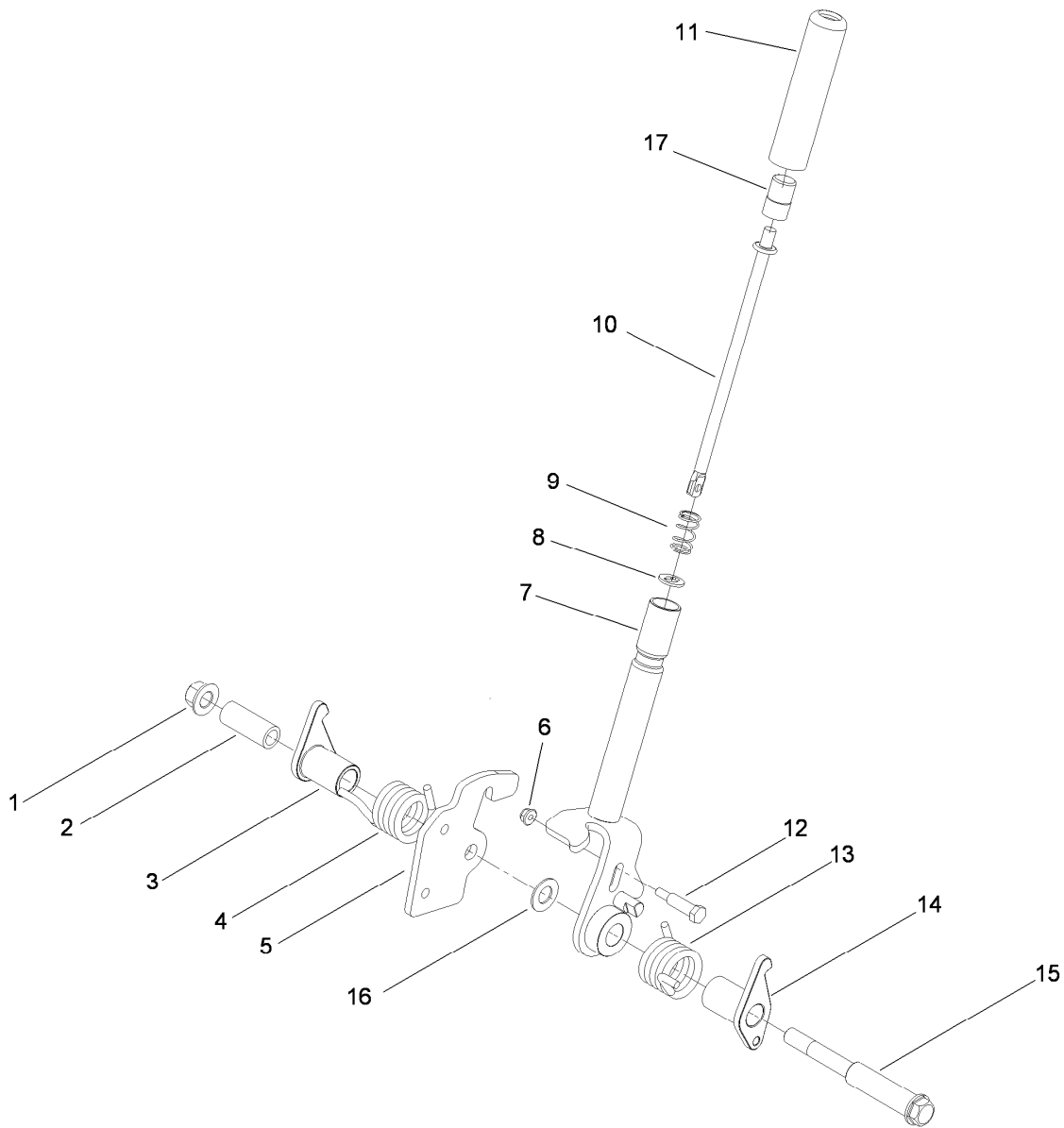

Brake Handle Assembly No. 116-1878

<i>Ref.</i>	<i>Part Number</i>	<i>Qty.</i>	<i>Description</i>	<i>Ref.</i>	<i>Part Number</i>	<i>Qty.</i>	<i>Description</i>
1	99-5107	1	Nut-Lock	10	115-3581	1	Rod-Release, Brake
2	117-0380	1	Spacer	11	115-3592	1	Grip
3	115-3580	1	Arm-Brake, LH	12	112-8387	1	Bolt-Shoulder
4	117-0376	1	Spring-Torsion, RH	13	117-0375	1	Spring-Torsion, LH
5	115-3574	1	Plate-Latch	14	115-3579	1	Arm-Brake, RH
6	104-7201	1	Nut-HF	15	117-0379	1	Bolt-Shoulder
7	116-1876-03	1	Brake Handle ASM	16	3256-26	1	Washer-Flat
8	114-1207	1	Washer-Special	17	115-2750	1	Knob
9	114-8187	1	Spring-Compression				

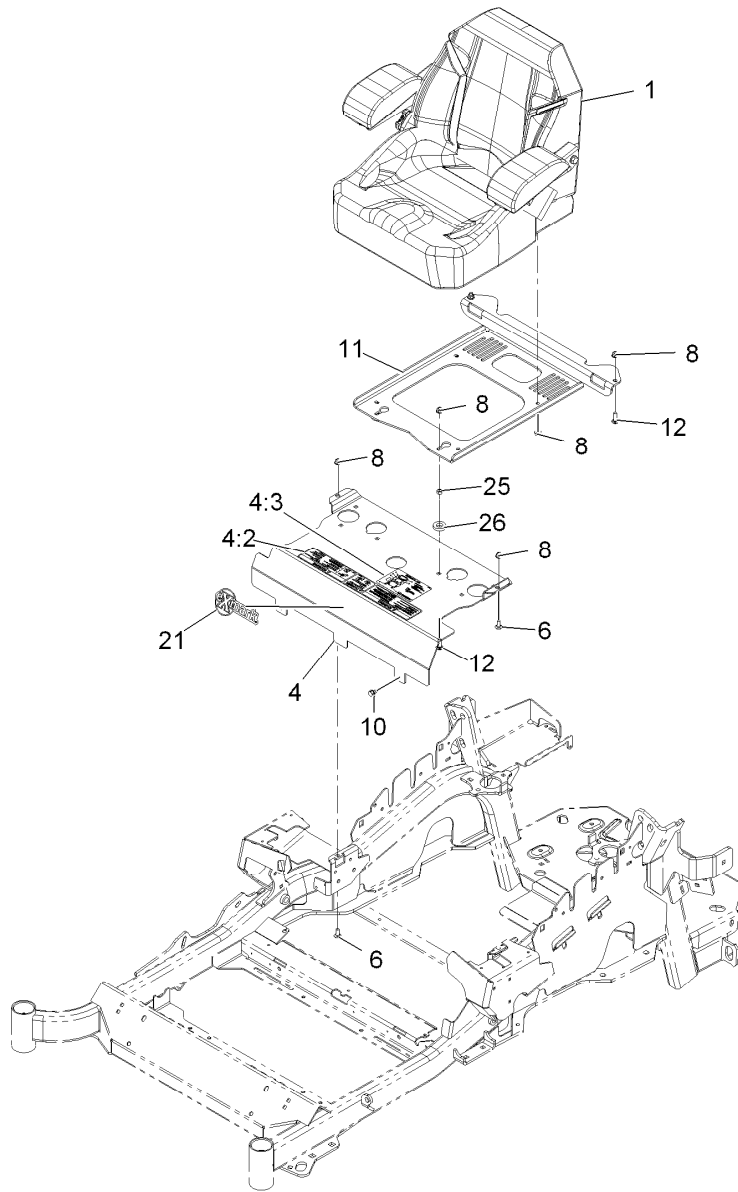

Seat Assembly

<i>Ref.</i>	<i>Part Number</i>	<i>Qty.</i>	<i>Description</i>
1	116-4474	1	Seat,Exmark Standard Service
4	116-3327	1	Mount-Seat
4:2	109-7069	1	Decal-Console
4:3	116-0211	1	Decal-Service Aid
6	3230-23	2	Bolt-Carriage 5/16-18 X 3/4 Short Neck
8	104-8300	10	Nut-Nyloc 5/16-18 Flg
10	9266934	2	Screw-HWH 5/16 X 1/2 Tf
11	116-0192-03	1	Plate-Support, Seat
12	3230-22	4	Bolt-Carriage 5/16-18 X 1 Sp
21	103-2883	1	Decal,Exmark Logo
25	3217-6	2	Nut-Hex 5/16-18
26	1-323539	2	Spacer-Blade Drive

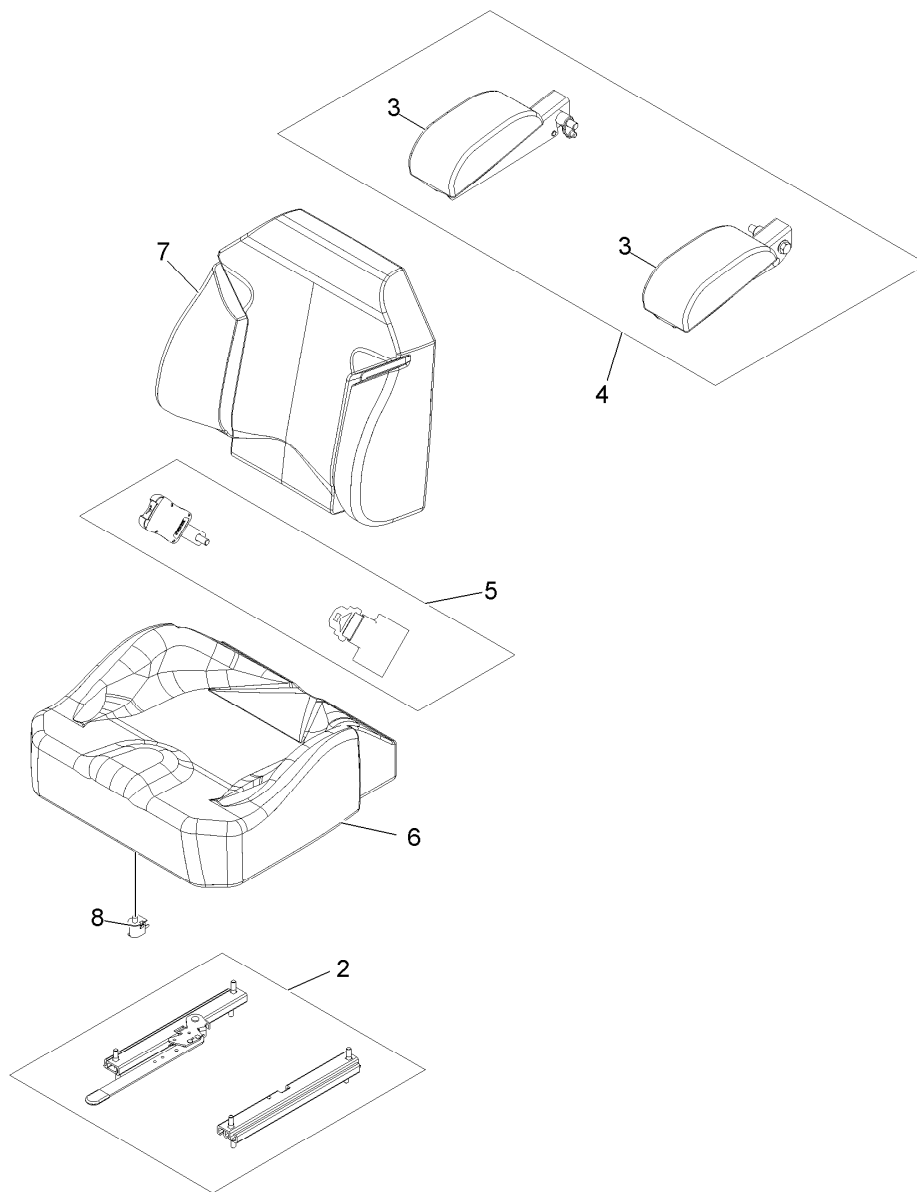

Seat W/Tracks Assembly No. 116-4474

<i>Ref.</i>	<i>Part Number</i>	<i>Qty.</i>	<i>Description</i>
2	109-9801	1	Seat Track Set
3	109-9802	1	Arm Rest Pad Set
4	109-9803	1	Arm Rest Set
5	109-9805	1	Seat Belt Kit
6	116-4925	1	Cover,Cushion
7	116-4926	1	Cover,Back
8	82-2190	1	Switch

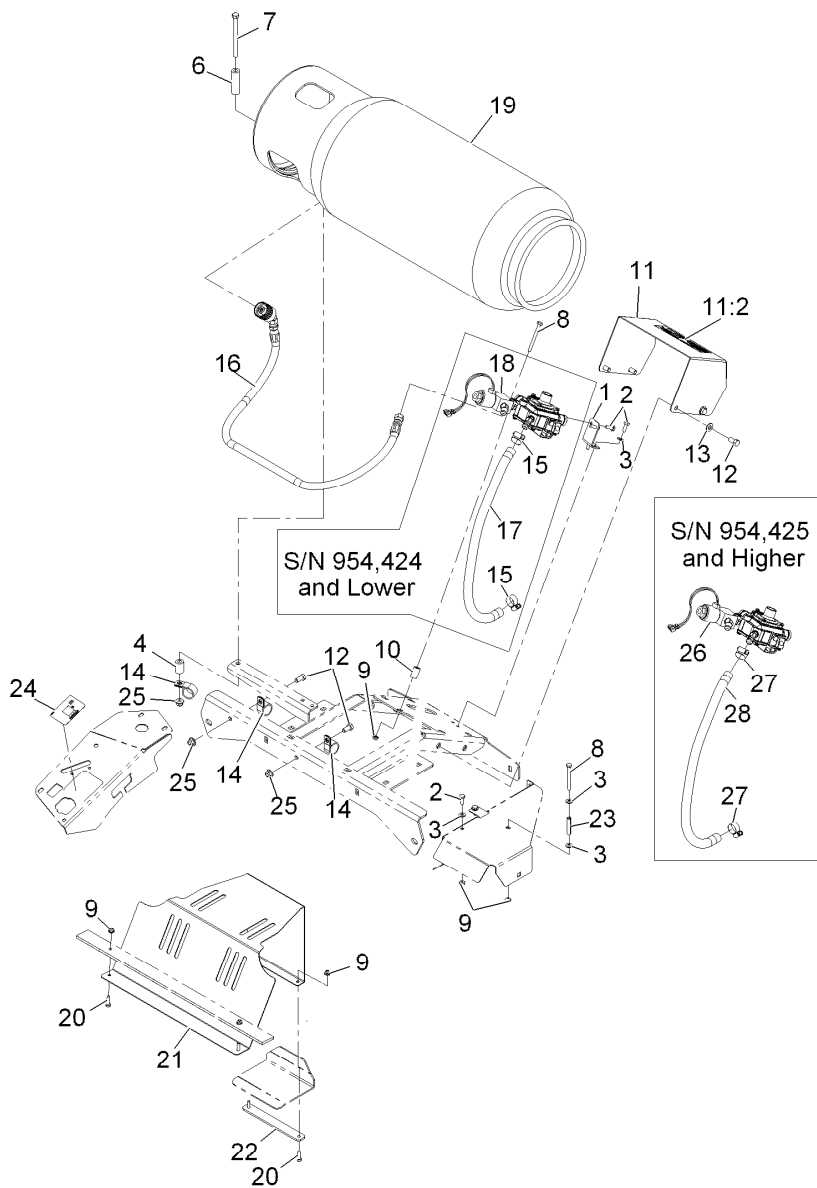

LP Valve, Tank and Hose Assembly

Ref.	Part Number	Qty.	Description	Ref.	Part Number	Qty.	Description
1	116-2571-03	1	Bracket-Regulator	15	97-1271	2	Clamp-Hose
2	321-4	6	Screw-HH 1/4-20 X 3/4	16	116-2821	1	LP Fuel Hose ASM
3	3256-22	6	Washer-1/4 Sae	17	116-2568	1	Hose-LP
4	103-1361	1	Spacer	18	116-2554	1	LP Solenoid Regulator ASM
6	1-633988	1	Spacer-Anchor, Clutch	19	116-1694	1	Tank-Lpg
7	323-23	1	Screw-HH 3/8-16 X 4-1/2	20	321-5	4	Screw-HH 1/4-20 X 7/8
8	321-14	2	Screw-HH 1/4-20 X 2 3/4	21	116-3358-03	1	Shield-Fan
9	104-7201	10	Nut-Nyloc 1/4-20 Flg	22	116-3359-03	1	Strap
10	94-7564	1	Spacer	23	56-7740	1	Spacer-Split
11	116-2818	1	Cover W/Decal	24	116-3446	1	Decal-Hour Meter
11:2	109-9906	1	Decal-Tank Replacement	25	104-8301	3	Nut-Nyloc 3/8-16 Flg
12	323-4	6	Screw-HH 3/8-16 X 3/4	26	116-5638	1	Asm-Solenoid Regulator LP
13	3256-24	4	Washer-3/8 Sae	27	1-543892	2	Hose Clamp
14	1-643312	3	Clip-Loom	28	116-5637	1	Hose-LP

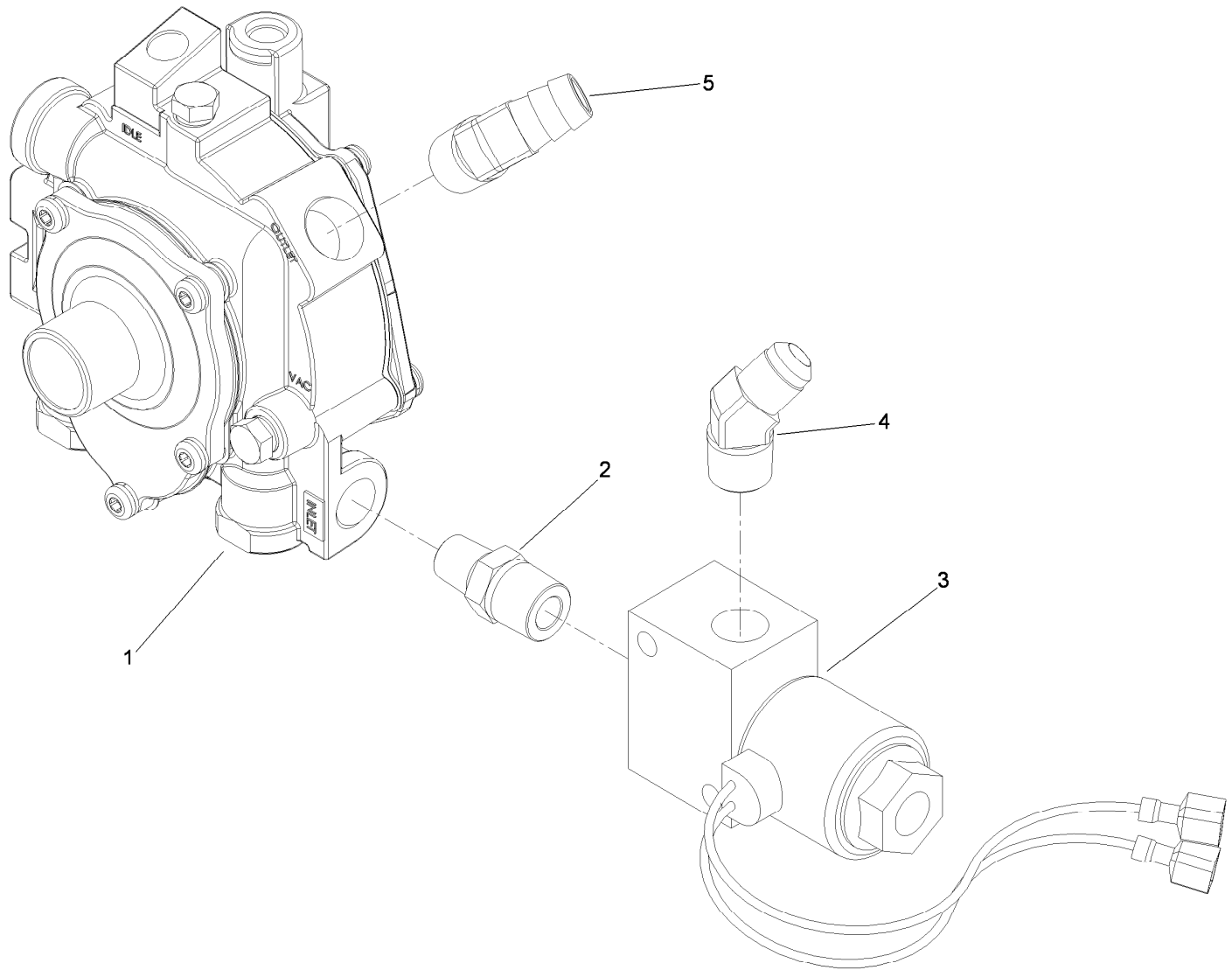

LP Solenoid Regulator Assembly No. 116-2554

<i>Ref.</i>	<i>Part Number</i>	<i>Qty.</i>	<i>Description</i>
1	116-2567	1	Regulator-LP, T60
2	93-1347	1	Coupling-Pipe, Male
3	116-2830	1	LP Solenoid Valve ASM
4	116-2569	1	Elbow
5	116-2570	1	Elbow

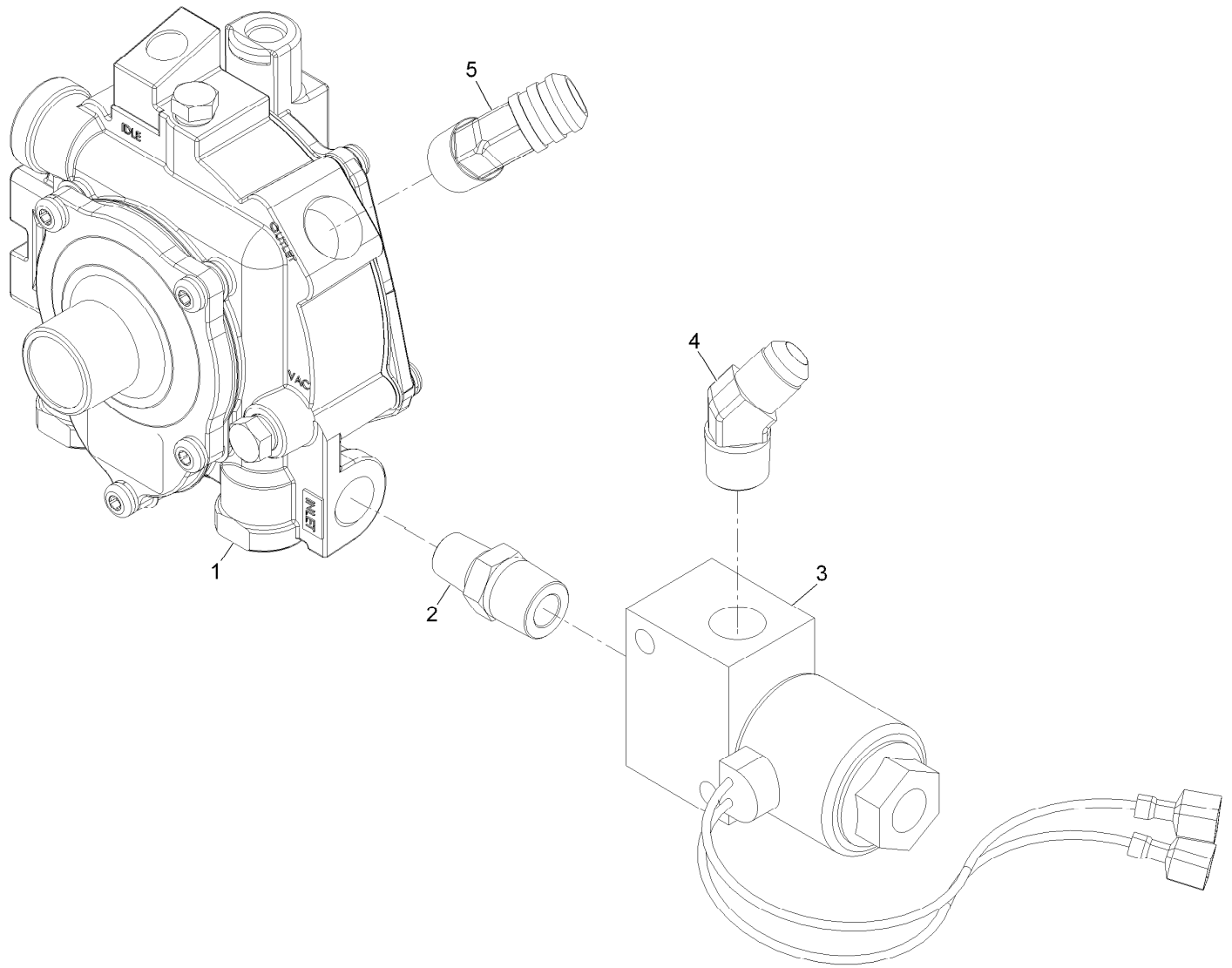

LP Solenoid Regulator Assembly No. 116-5638

<i>Ref.</i>	<i>Part Number</i>	<i>Qty.</i>	<i>Description</i>
1	116-2567	1	Regulator-LP, T60
2	93-1347	1	Coupling-Pipe, Male
3	116-2830	1	LP Solenoid Valve ASM
4	116-2569	1	Elbow
5	116-5636	1	Elbow

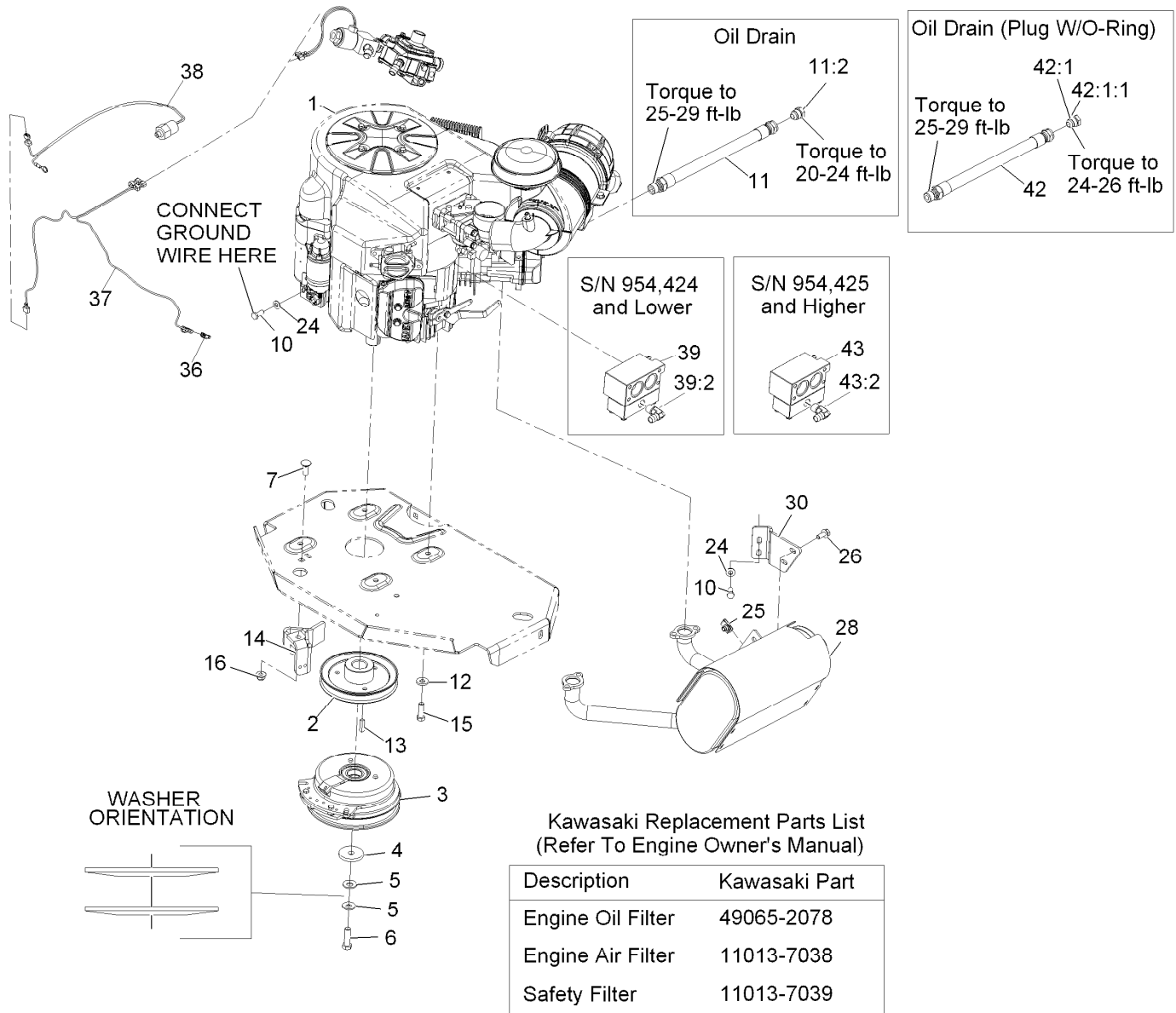

Engine Assembly

Ref.	Part Number	Qty.	Description	Ref.	Part Number	Qty.	Description
1		1	Engine-Kawasaki, Fx801V-S04-R ●■	24	1-303334	3	Washer-Spring Disc 5/16
2	109-9905	1	Sheave	25	94-2413	2	U-Nut
3	116-1620	1	Clutch Kit	26	3234-5	2	Screw-HH Flg 5/16-18 X 3/4
4	109-6919	1	Washer-Clutch	28	116-1712	1	Muffler
5	1-603610	2	Washer-Spring Disc 7/16	30	116-0203	1	Bracket-Muffler
6	109-9761	1	Screw-HH 7/16-20 X 1 1/2 W/Loctite ◆	36	32170-079	1	Terminal-Tab
7	3231-22	1	Bolt-Carriage 3/8-16 X 1	37	116-2857	1	Wire Harness
10	33114-020	3	Screw-HH M8-1.25 X 20Mm	38	116-2842	1	Oil Pressure Switch ASM
11	109-4490	1	Oil Drain Hose ASM ▲	39	116-4689	1	Mixer ASM
11:2	109-1012	1	Plug	39:2	116-1127	1	Elbow-90 DEG
12	98-5975	4	Washer-Spring Disc 3/8	42	116-4924	1	Engine Hose Oil Drain ASM ▲
13	1-807259	1	Key-Machine 1/4 X 1/4 X 1	42:1	353-508	1	Plug-W/O-Ring
14	116-2612-01	1	Clutch-Anchor	42:1:1	237-42	1	O-Ring
15	323-7	4	Screw-HH 3/8-16 X 1 1/4	43	116-5639	1	Asm-Mixer
16	104-8301	1	Nut-Nyloc 3/8-16 Flg	43:2	116-5635	1	Elbow-90 Deg

● Not serviced separately

▲ Use a Teflon Pipe Sealant or equivalent on threads.

◆ Use Pro-Lock, Nut Type (P/N 1-840022, .5ml tube) on threads.

■ Obtain parts from www.kawpowerepc.com

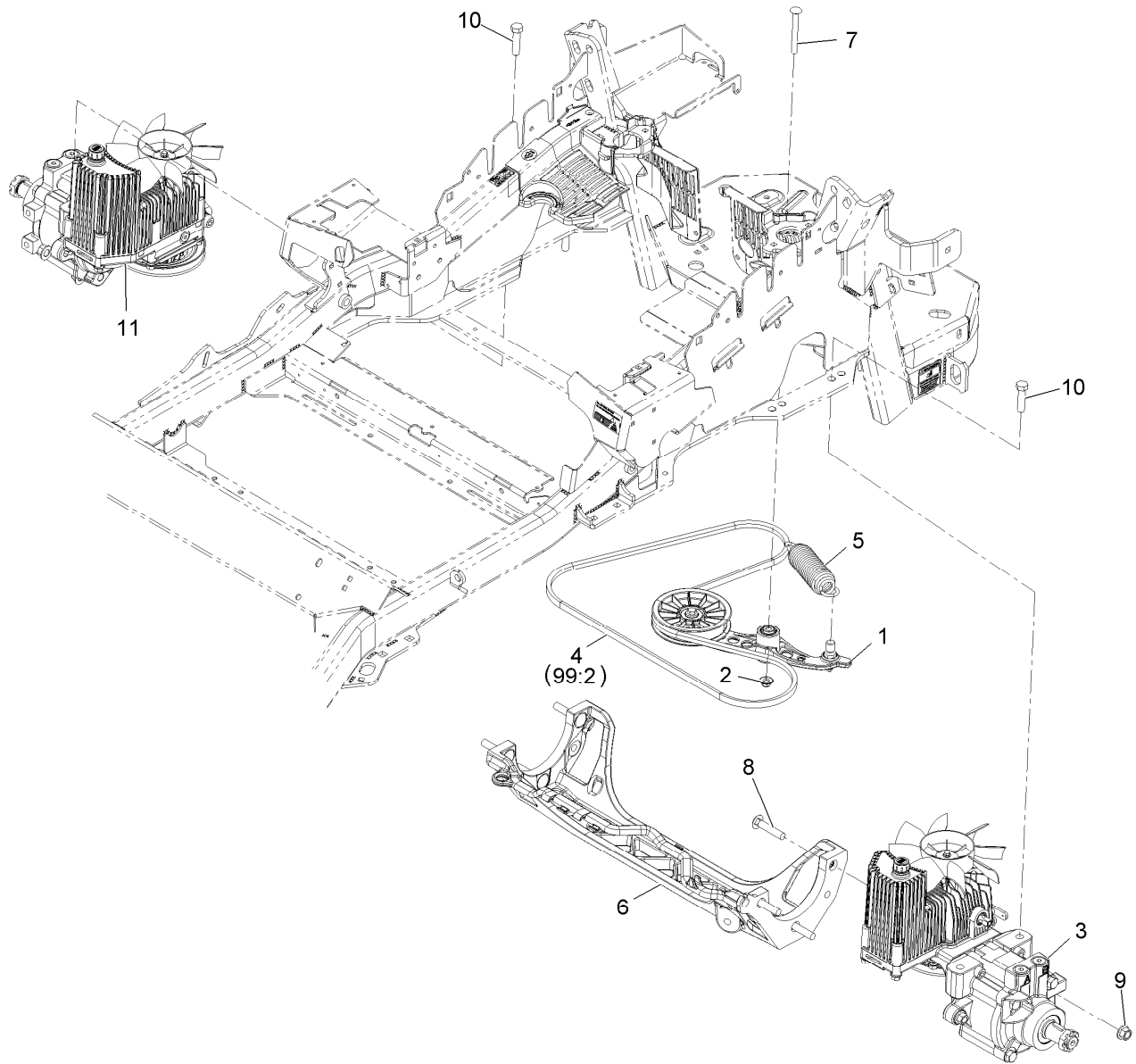

Hydraulic Assembly

Ref.	Part Number	Qty.	Description	Ref.	Part Number	Qty.	Description
1	116-1255	1	Pump Idler ASM	10	325-8	4	Screw-HH 1/2-13 X 1 1/4
2	109-6658	1	Nut-Nyloc 3/8-16 Flg	11	116-1325	1	RH Hydro ASM (12Cc W/Shock)
3	116-1324	1	LH Hydro ASM (12Cc W/Shock)	99	109-9828	1	Bottle-Oil, 32Oz Hydraulic ●
4	109-3388	1	Belt	99	116-0164	1	Filter-Hydro ●
5	116-0133	1	Extension-Spring	99	116-1218	1	Bottle,Oil 1 Gallon Hydraulic ●
6	109-9375	1	Cradle-Hydro	99	116-3270	1	Kit, Hydro Service ●
7	116-1502	1	Bolt-Carriage Shoulder 3/8-16 X 3 1/2	99:1	109-9828	4	Bottle-Oil, 32Oz Hydraulic ●
8	3233-34	6	Bolt-Carriage 1/2-13 X 2 1/2	99:2	109-3388	1	Belt
9	99-5107	6	Nut-Lock 1/2-13	99:3	116-0164	2	Filter-Hydro ●

● Not illustrated

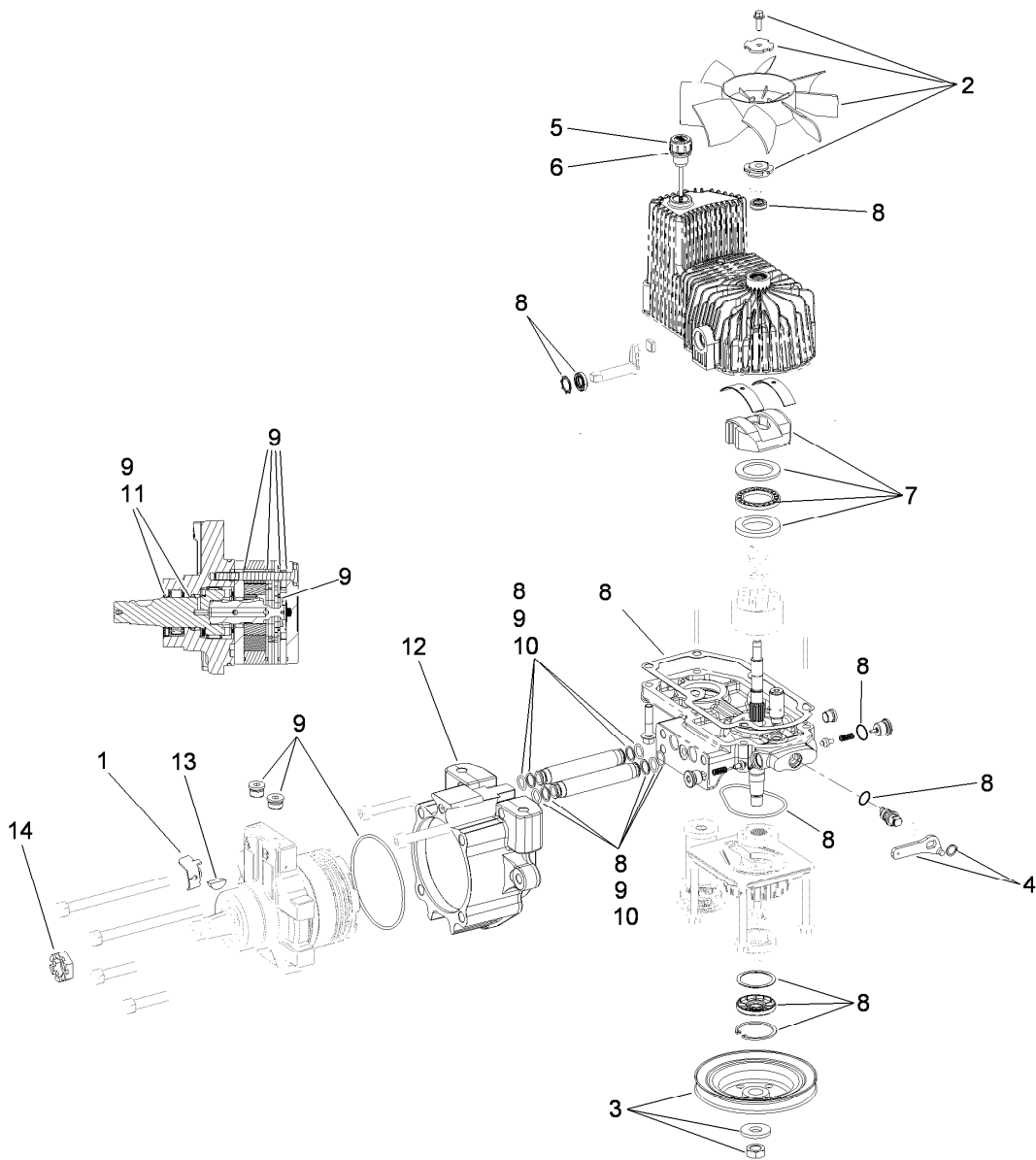

LH Hydro Assembly No. 116-1326

Ref.	Part Number	Qty.	Description
1	116-1758	1	Bracket-Anchor, Cable
2	116-0233	1	Fan Kit
3	116-0234	1	Pulley Kit
4	116-0235	1	Handle-Bypass Valve, Hydro
5	116-0236	1	Dipstick-Hydro W/Gasket
6	116-0237	1	Gasket-Dipstick, Hydro
7	116-1367	1	Swash Block Kit
8	116-1368	1	Pump Seal Kit
9	116-1369	1	Motor Seal Kit
10	116-1370	1	Tube Seal Kit
11	116-1371	1	Output Shaft Seal Kit
12	116-1372	1	Cup-Nose
13	3257-42	1	Key-Woodruff
14	1-809036	1	Nut-HH
99	116-1373	1	Flow Test Kit ●

● Not illustrated

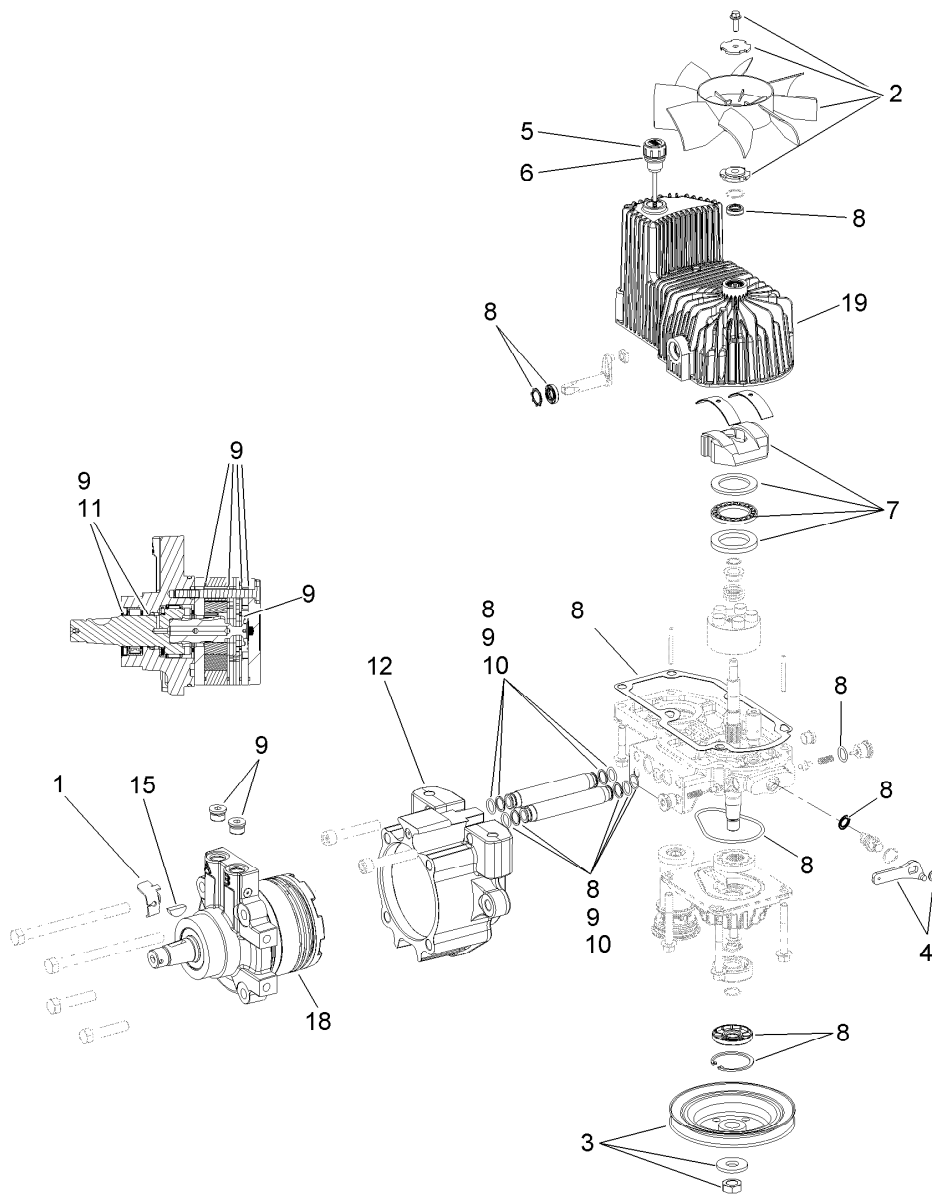

RH Hydro Assembly No. 116-1325

<i>Ref.</i>	<i>Part Number</i>	<i>Qty.</i>	<i>Description</i>	<i>Ref.</i>	<i>Part Number</i>	<i>Qty.</i>	<i>Description</i>
1	116-1758	1	Bracket-Anchor, Cable	9	116-1369	1	Motor Seal Kit
2	116-0233	1	Fan Kit	10	116-1370	1	Tube Seal Kit
3	116-0234	1	Pulley Kit	11	116-1371	1	Output Shaft Seal Kit
4	116-0235	1	Handle-Bypass Valve, Hydro	12	116-2992	1	Cup-Nose Hydro Dry
5	116-0236	1	Dipstick-Hydro W/Gasket	15	3257-42	1	Key-Woodruff 5/16 X 1
6	116-0237	1	Gasket-Dipstick, Hydro	18	116-2989	1	Motor-Wheel RH Dry 240Cc
7	116-1367	1	Swash Block Kit	19	116-3288	1	Housing-RH
8	116-1368	1	Pump Seal Kit	99	116-1373	1	Flow Test Kit ●

● Not illustrated

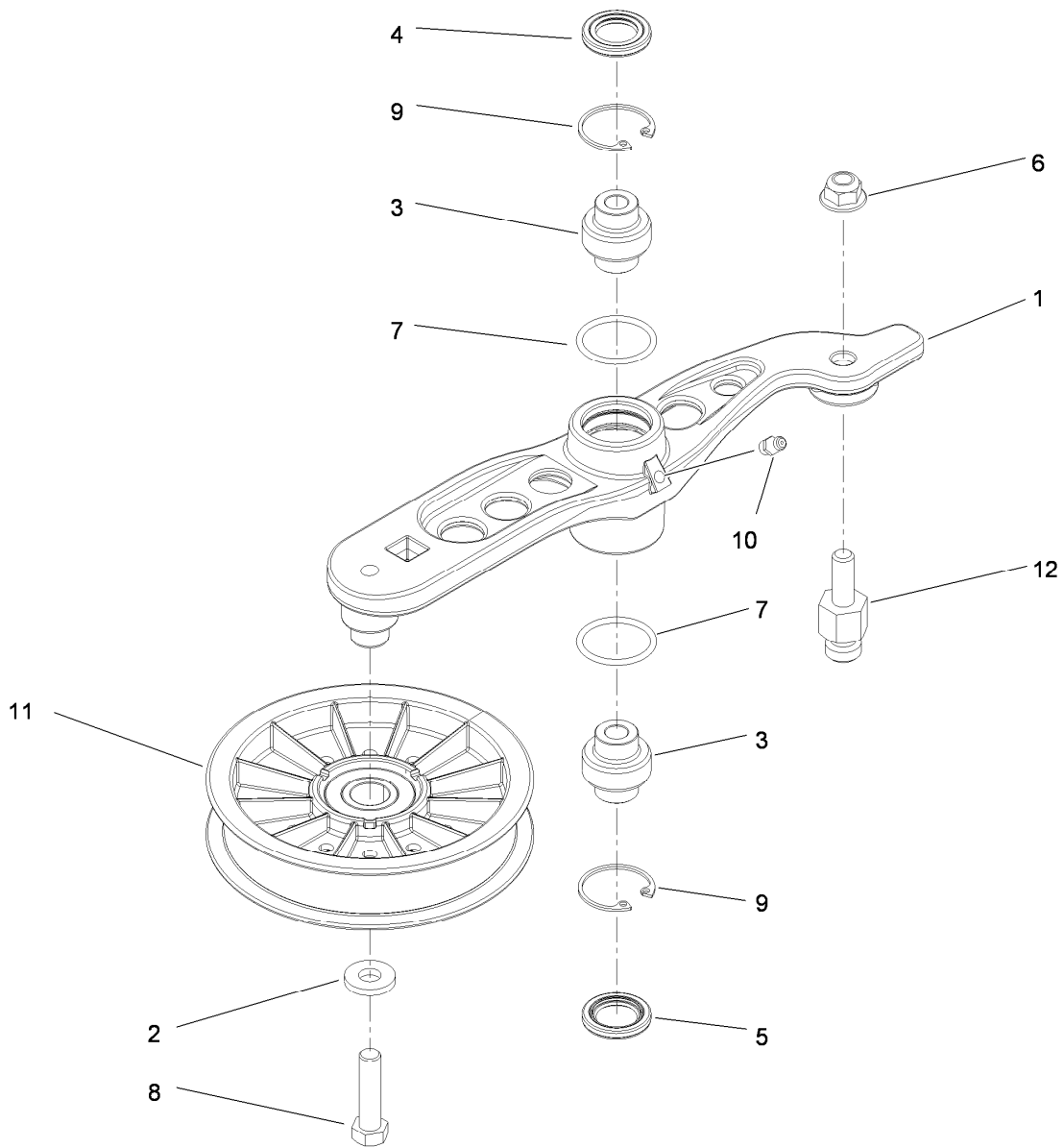

Pump Idler Assembly No. 116-1255

Ref.	Part Number	Qty.	Description
1		1	Arm-Pump, Idler ●
2	43-0940	1	Spacer
3	103-3504	2	Bearing-Spherical
4	103-3505	1	Seal-Double Lip
5	103-3506	1	Seal-Single Lip
6	109-6658	1	Nut-Nyloc 3/8-16 Flg
7	106-7159	2	O-Ring
8	323-8	1	Screw-HH 3/8-16 X 1 1/2
9	32120-10	2	Ring-Retaining
10	302-19	1	Zerk-1/4-28 Str
11	109-8076	1	Pulley-Idler
12	116-3467	1	Pin-Spring, Anchor

● Not serviced separately

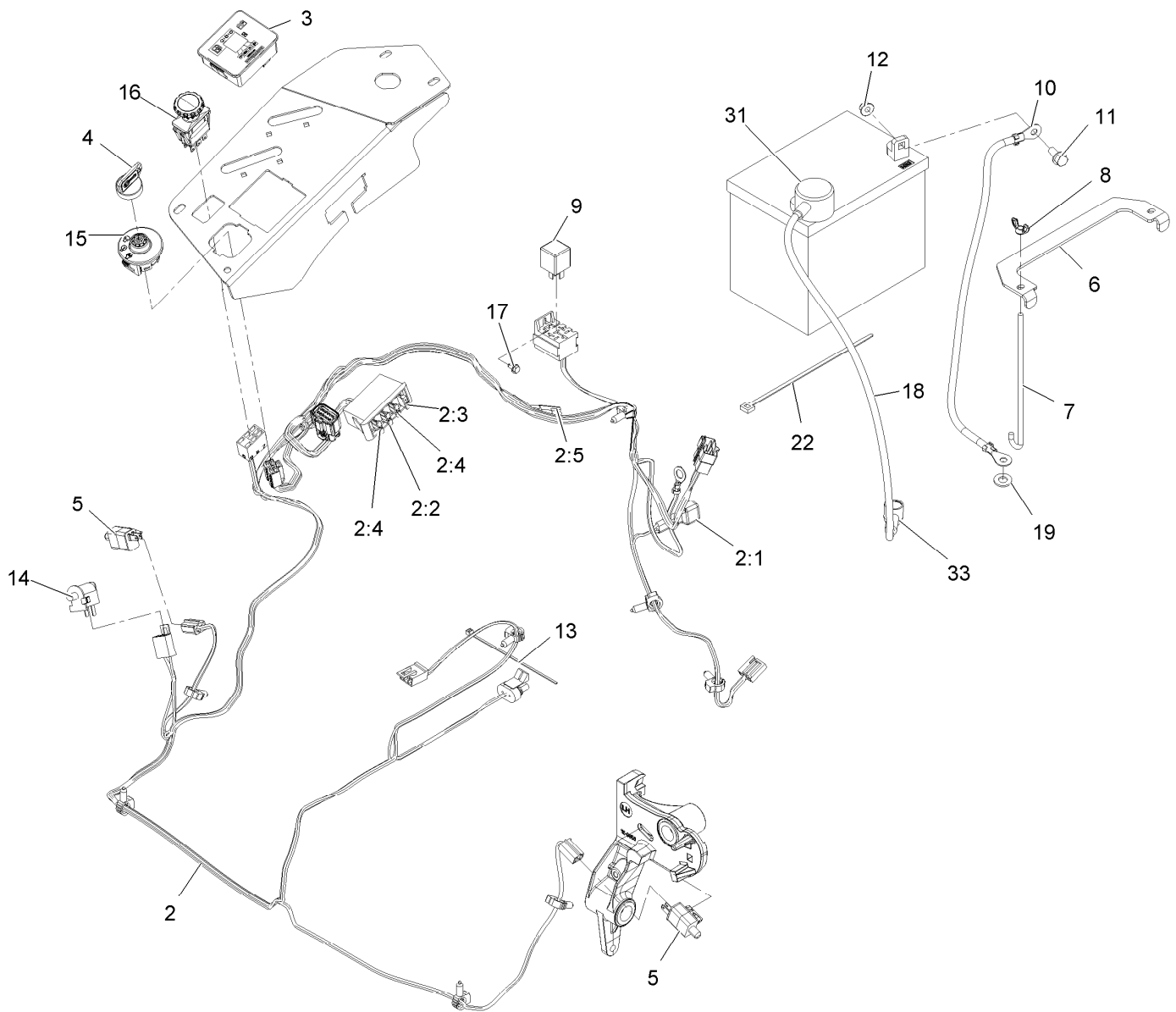

Electrical Assembly

Ref.	Part Number	Qty.	Description	Ref.	Part Number	Qty.	Description
2	115-2796	1	Harness-Wire, Main ●	10	114-1218	1	Cable-Battery, Negative
2:1	103-3895	1	Diode-Tvs	11	3234-5	2	Screw-HH Flg 5/16-18 X 3/4
2:2	218-578	1	Fuse-Blade, 10 Amp	12	104-8300	2	Nut-Nyloc 5/16-18 Flg
2:3	109355	1	Fuse-Blade, 15 Amp	13	1-303287	3	Tie-Cable 5 1/2 (Small)
2:4	109102	2	Fuse-Blade, 25 Amp	14	82-2190	1	Switch
2:5	116-0053	1	Cap-Plug	15	117-2221	1	Switch-Ignition
3	117-3882	1	Fuel/Hour Meter ASM	16	116-0124	1	Switch-PTO, 10A
4	1-603511	1	Key-Ignition	17	104-2065	1	Screw-HWH #10-24 X 3/8
4	103-2106	1	Key-Exmark Logo	18	115-3864	1	Cable-Battery, Positive
5	110-6765	2	Switch-Single Pole No	19	3256-24	1	Washer-3/8 Sae
6	116-0042-03	1	Strap-Tie Down, Battery	22	1-303335	1	Tie-Cable 7 15/16 (Large)
7	1-633651	2	Bolt-Holddown	31	109-2407	1	Insulator-Battery
8	1-543792	2	Wingnut-Nyloc 1/4-20	33	1-543393	1	Insulator-Solenoid
9	1-643275	1	Relay-12Vdc 40 Amp				

● Use dielectric grease on all wiring harness connectors.

Notes:

SEE EXMARK'S COMPLETE LINE OF ACCESSORIES AND OPTIONS

MID-MOUNT RIDING ACCESSORIES AND OPTIONS

CUSTOM RIDE SEAT SUSPENSION SYSTEM	OPERATOR CONTROLLED DISCHARGE
FULL SUSPENSION SEAT	ROLL OVER PROTECTION SYSTEM (ROPS)
DECK LIFT ASSIST KIT	SUN SHADE
HITCH KIT	TRASH CONTAINER
LIGHT KIT	TURF STRIPER
12V POWER PORT	ULTRA VAC COLLECTION SYSTEM
MICRO-MULCH SYSTEM	ULTRA VAC QUICK DISPOSAL SYSTEM

OUT-FRONT RIDING ACCESSORIES AND OPTIONS

CUSTOM RIDE SEAT SUSPENSION SYSTEM	SNOW BLADE
DUAL-TAIL WHEEL	SNOWBLOWER
FLOOR PAN EXTENDER	SUN SHADE
HITCH KIT	TRASH CONTAINER
LIGHT KIT	ULTRA VAC COLLECTION SYSTEM
MICRO-MULCH SYSTEM	ULTRA VAC QUICK DISPOSAL SYSTEM
ROLL OVER PROTECTION SYSTEM (ROPS)	WEATHER CAB

WALK-BEHIND ACCESSORIES AND OPTIONS

GRASS CATCHER	TURF STRIPER
MICRO-MULCH SYSTEM	STANDON

Place Model No. and Serial No.
Label Here (Included in the Literature
Pack) or Fill in Below

Model No. _____

Serial No. _____

Date Purchased _____

Engine Model No. and Spec. No. _____

Engine Serial No. (E/No) _____

© 2011 Exmark Mfg. Co., Inc.
Industrial Park Box 808
Beatrice, NE 68310
All Rights Reserved

Part No. 4500-831 Rev. B
(402) 223-6300
Fax (402) 223-5489
Printed in the USA.

