

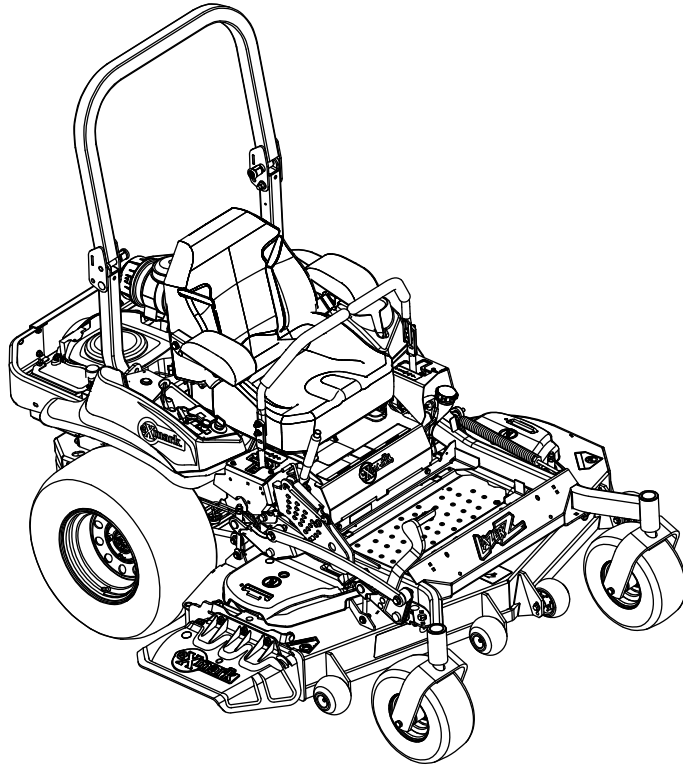

LAZER Z[®] X-SERIES

Model No. LZX27KC606—Serial No. 920000 and Up



Parts Manual

Part No. 4500-786 Rev. A

Ordering Replacement Parts

To order replacement parts, please supply the part number, the quantity, and the description of each part desired.

Understanding Reference Numbers

Each identified part in an illustration has a reference number. The reference number for a part also appears in the parts list, along with other information about the part.

This catalog uses two special reference number formats, one to indicate parts in a service assembly and another to indicate the quantity of a given part in an illustration.

Service Assembly Reference Numbers

Parts in service assemblies have reference numbers in the form a:b. The a represents the reference number of the entire service assembly and the b represents a sequential number unique to each part within the service assembly.

For example, a wheel assembly might be identified by reference number 6, the tire by 6:1, the valve by 6:2, and the wheel by 6:3. When you order the assembly identified by reference number 6, you receive all parts identified by reference numbers 6:1, 6:2, and 6:3. However, you may also order any part individually. Reference numbers of this type appear in illustration and in parts lists.

Reference Numbers Indicating Quantity

In an illustration, if a reference number indicates more than one part, the reference number has the form nX y. The n represents the quantity of the part, the X is the multiplication symbol, and the y represents the reference number.

For example, in an illustration, the reference number 2X 37 means that two of the parts identified by reference number 37 are indicated.

List of Abbreviations

AR: as required	HOC: height-of-cut	RRB: rear roller brush
ASM: assembly	HSBH: hex socket button head	SFH: slotted fillister head
BBC: blade brake control	HSFH: hex socket flat head	SHH: slotted hex head
BHTF: button head thread forming	HSH: hex socket head	SHWH: slotted hex washer head
CARR: carriage	HWH: hex washer head	SPH: slotted pan head
CCW: counter clockwise	HWTF: hex washer head thread forming	SQH: square head
CW: clockwise	HYD: hydraulic	SRH: slotted round head
DEG: degrees	LH: left hand	STD: standard
DPA: Dual Point Adjustment	LP: Liquid Propane	TAP: self tapping
ECM: electronic control module	NI: nylon insert	TTH: torx truss head
EXT: external	NPTF: national pipe thread fine	
FH: flat head	PFH: phillips flat head	
GA: gauge	PPH: phillips pan head	
HD: heavy-duty	PPHTF: phillips pan head thread forming	
HF: hex flange	PRH: phillips round head	
HH: hex head	PTH: phillips truss head	
HHF: hex head flange	PTO: power-take-off	
HHFTF: hex head flange thread forming	RH: right hand	
HJ: hex jam	ROPS: roll-over protection system	
HLH: hex lag head		

Touch Up Paint

Exmark black touch up spray paint – gloss black.

Exmark red touch up paint (spray paint – P/N 1-850337 - .6 oz liquid bottle – P/N 103-9140).

EXMARK PARTS PLUS

PARTS

OVERNIGHT

OR *FREE**

If your Exmark dealer does not have the Exmark part in stock, Exmark will get the parts to the dealer the next business day or the part will be FREE Guaranteed!! (Some restrictions apply. See your participating Exmark Dealer for details.)

Contents

Complete Deck Assembly	5
Deck Assembly	6
Deck W/Decals Assembly No. 116-4232	8
Deck Idler Assembly No. 116-3755	9
Cutter Housing Assembly No. 103-9539	10
Main Frame Assembly	11
Roll-Over Protection System Assembly No. 116-0230	12
Caster Wheel and Fork Assembly	13
Deck Lift Assembly	14
Height-of-Cut Assembly No. 109-7438	15
Controls Assembly	16
Motion Control Assembly	17
Rear Wheel and Park Brake Assembly	18
Brake Handle Assembly No. 116-1878	19
Seat Assembly	20
Seat W/Tracks Assembly No. 116-4474	21
Fuel Tank Mounting Assembly	22
Fuel Tank Assembly No. 116-3979	23
Engine Assembly	24
Hydraulic Assembly	25
LH Hydro Assembly No. 116-1326	26
RH Hydro Assembly No. 116-1327	27
Pump Idler Assembly No. 116-1255	28
Electrical Assembly	29

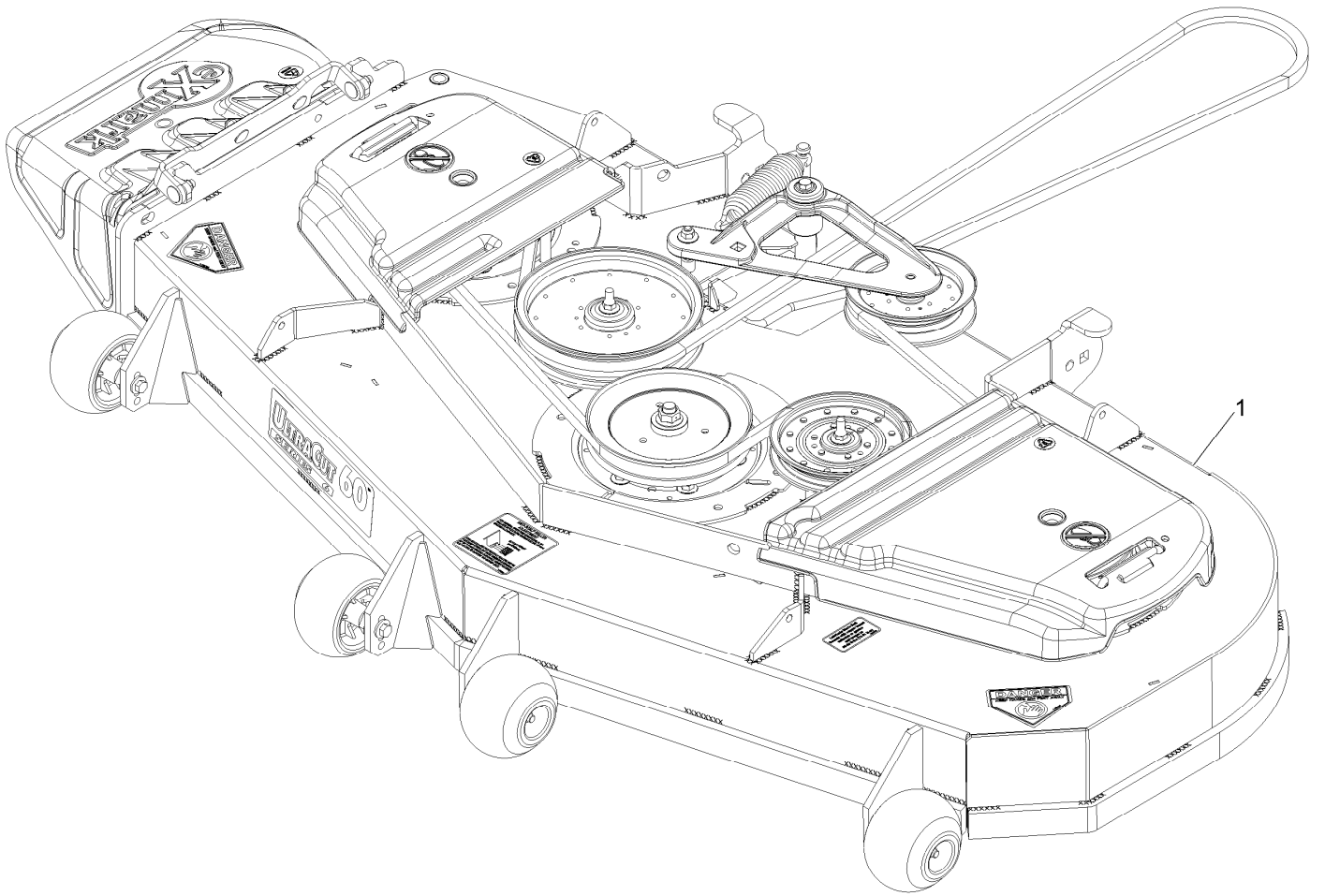

Complete Deck Assembly

<i>Ref.</i>	<i>Part Number</i>	<i>Qty.</i>	<i>Description</i>
1	109-9647	1	ASM,Deck Complete 606

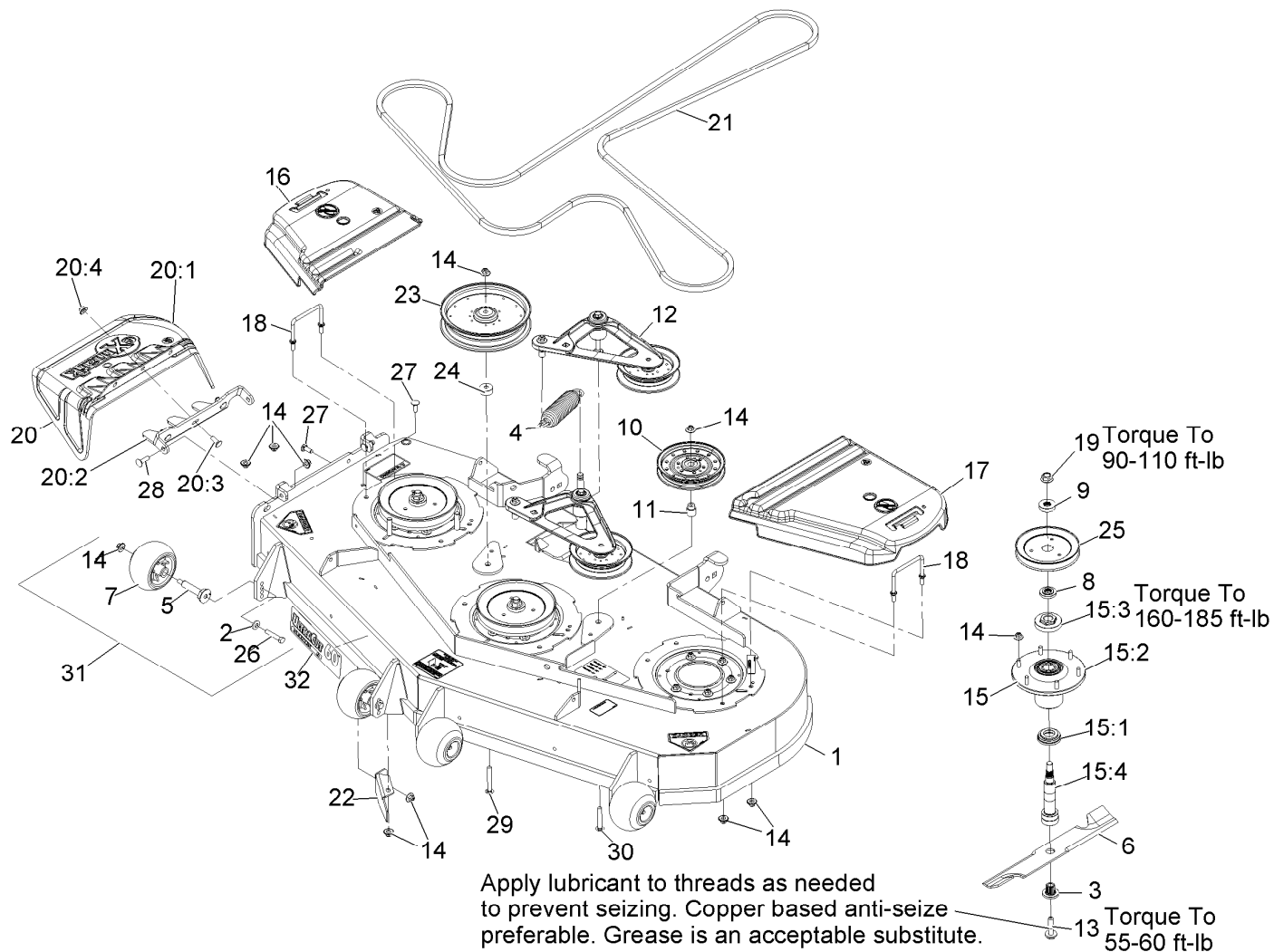

Deck Assembly

Ref.	Part Number	Qty.	Description	Ref.	Part Number	Qty.	Description
1	116-4232	1	Deck ASM,W/Decals 60	12	116-3755	1	Deck Idler ASM
2	98-5975	4	Washer-Spring Disc 3/8	13	109-9220	3	Screw-Sems 1/2-20 X 2.19
3	103-3037	3	Bushing,Splined	14	109-6658	32	Nut-Nyloc 3/8-16 Flg
4	116-0133	1	Extension-Spring	15	109-6917	3	ASM,Spindle Housing
5	109-9851	4	Axle, Anti-Scalp Roller	15:1	103-9504	1	Guard,Bottom
6	103-6383	3	Blade, Solid 20.5 (.94 Hole)	15:2	103-9539	1	ASM,Cutter Housing
6	103-6388	3	Blade, Low Lift 20.5 (.94 Hole)	15:3	109-0916	1	Nut, Spindle 7/8-14
6	103-6393	3	Blade, Mulch 20.5 (.94 Hole)	15:4	109-6881	1	Spindle,Double Spline ■
6	103-6398	3	Blade, Extreme 20.5 (.94 Hole)	16	116-0094	1	Cover-Belt, RH
6	103-6403	3	Blade, Notched 20.5 (.94 Hole)	17	109-6938	1	Cover-Belt, LH
7	103-8415	4	Roller,Anti-Scalp	18	109-6982	2	Wireform-Cover
8	103-9522	3	Spacer,Splined Stepped	19	109-7033	3	Nut-Flange 5/8-18 Centerlock
9	103-9523	3	Spacer,Splined	20	109-7188	1	ASM,Discharge Chute
10	1-633109	1	Idler-Flat	20:1	109-2738	1	Chute,Discharge
11	1-633456	1	Bushing,Idler	20:2	109-8675-01	1	Bracket,Discharge Chute
				20:3	3231-22	3	Bolt-Carriage 3/8-16 X 1
				20:4	109-6658	3	Nut-Nyloc 3/8-16 Flg
				21	109-8073	1	Belt,V-5V-198.75

● Requires installation of mulch kit for proper mulching. See your Exmark dealer for details.

■ Apply Mobil HTS grease (P/N 103-5217 1.5 oz packet) (or a food-grade anti-seize). See operator s manual for locations.

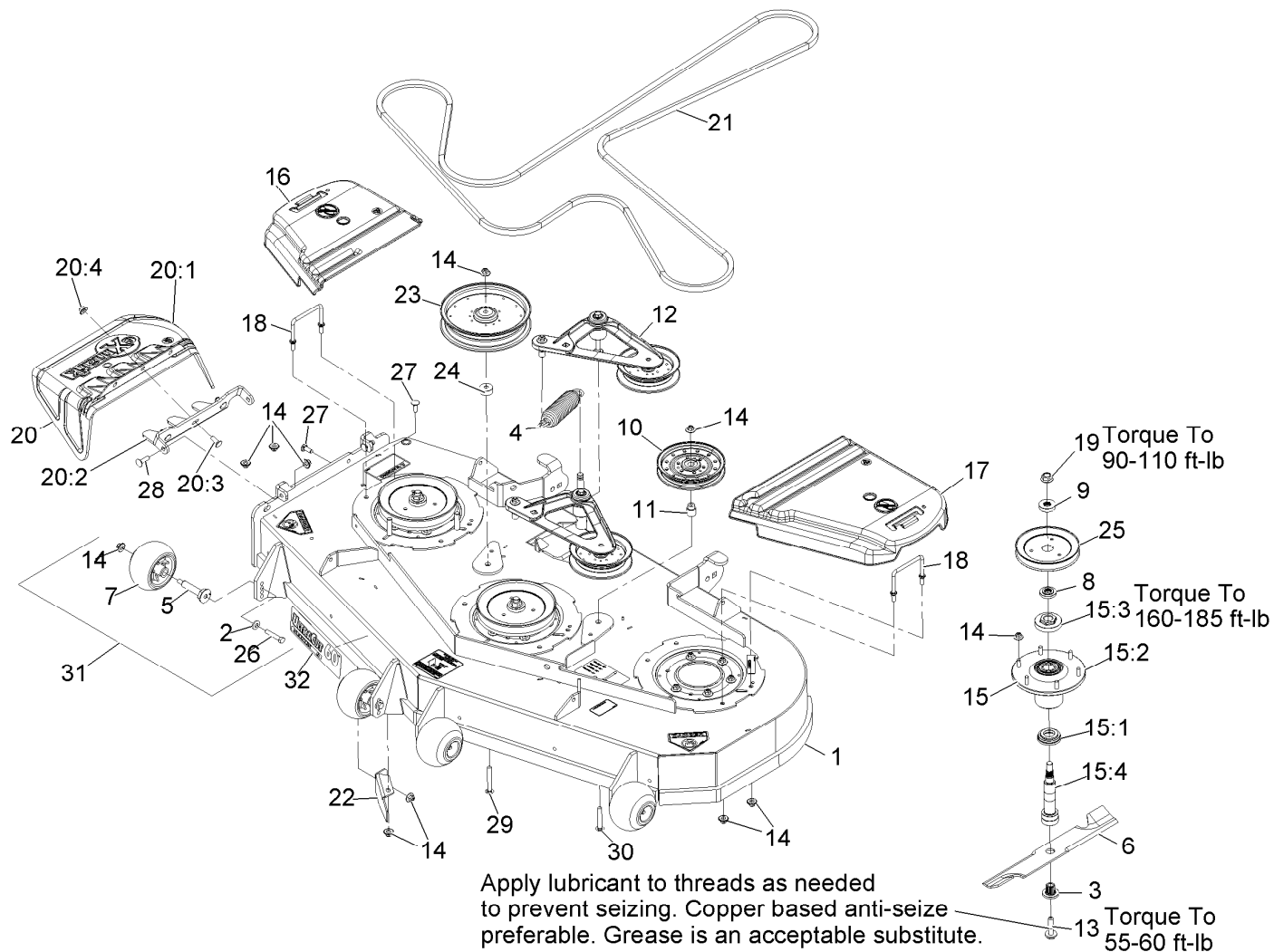

Deck Assembly (continued)

Ref.	Part Number	Qty.	Description	Ref.	Part Number	Qty.	Description
22	109-9915-01	1	Baffle,Discharge 52/60	28	3231-28	2	Bolt-Carriage 3/8-16 X 1 1/4
23	109-8590	1	Pulley-Idler	29	3231-42	1	Bolt-Carriage 3/8-16 X 3
24	103-2956	1	Spacer-Idler	30	3231-44	1	Bolt-Carriage 3/8-16 X 2 1/2
25	109-9511	3	Sheave,Blade Drive 7.25	31	109-2098	4	Kit, Antiscalp
26	3211-46	4	Screw-HH 3/8-24 X 2 Gr8	32	109-9439	1	Decal,Ultracut 60 Series 6
27	3231-22	2	Bolt-Carriage 3/8-16 X 1				

● Requires installation of mulch kit for proper mulching. See your Exmark dealer for details.

■ Apply Mobil HTS grease (P/N 103-5217 1.5 oz packet) (or a food-grade anti-seize). See operator s manual for locations.

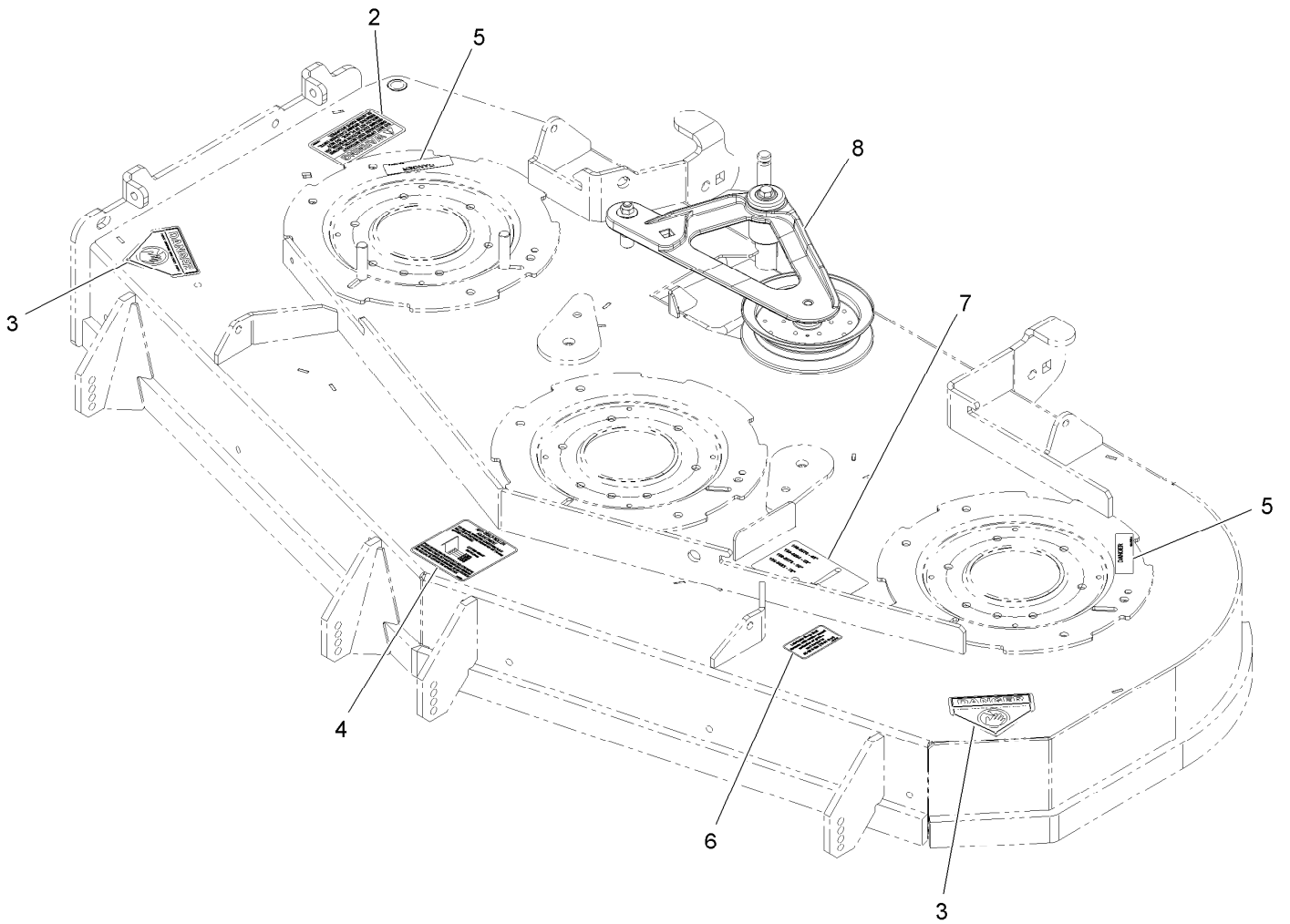

Deck W/Decals Assembly No. 116-4232

<i>Ref.</i>	<i>Part Number</i>	<i>Qty.</i>	<i>Description</i>
2	1-303508	1	Decal-Warning, Discharge
3	1-403005	2	Decal-Danger
4	1-633922	1	Decal,Antiscalp
5	98-5954	2	Decal-Cover, Missing
6	109-3148	1	Decal,Bolt Torque
7	109-9361	1	Decal,Belt Routing
8	116-3755	1	Deck Idler ASM

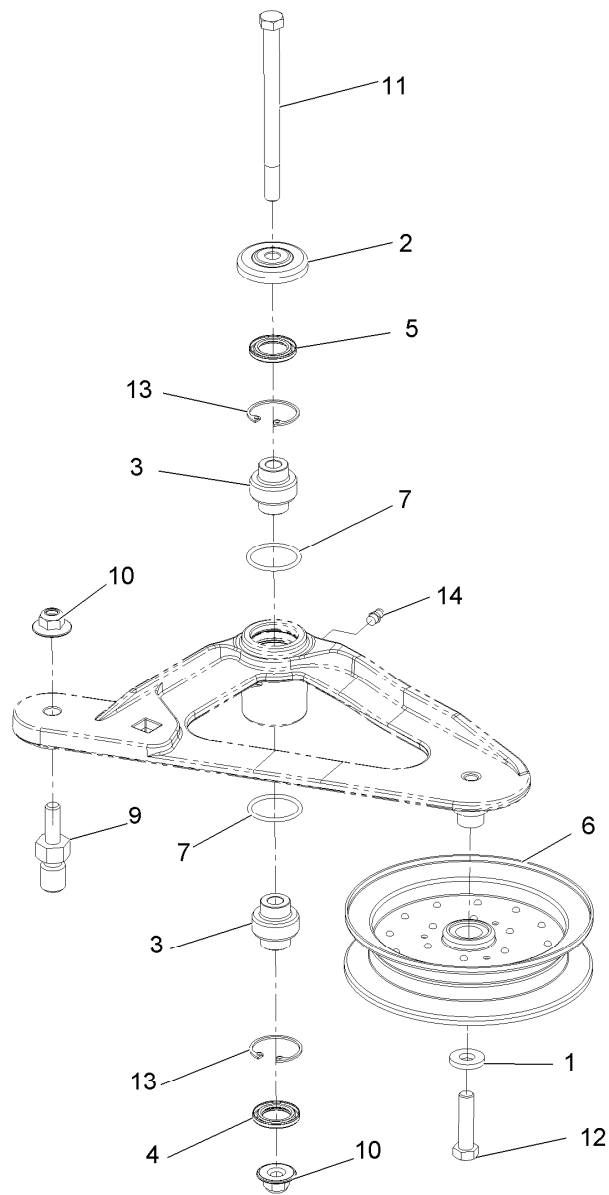

Deck Idler Assembly No. 116-3755

<i>Ref.</i>	<i>Part Number</i>	<i>Qty.</i>	<i>Description</i>
1	43-0940	1	Spacer-Hub, Blower
2	103-2916	1	Guard-Top
3	103-3504	2	Bearing-Spherical
4	103-3505	1	Seal-Double Lip
5	103-3506	1	Seal-Single Lip
6	103-8743	1	Pulley-Idler, Flanged
7	106-7159	2	O-Ring
9	116-3467	1	Pin, Spring Anchor
10	109-6658	2	Nut-Nyloc 3/8-16 Flg
11	109-7409	1	Screw-Shoulder 3/8-16 X 5
12	323-8	1	Screw-HH 3/8-16 X 1 1/2
13	32120-10	2	Ring-Retaining
14	302-19	1	Zerk-1/4-28 Str

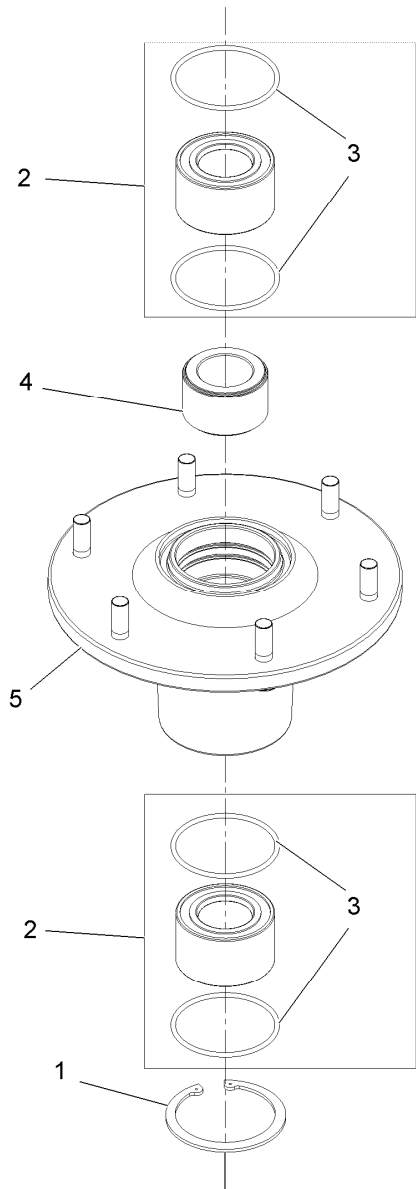

Cutter Housing Assembly No. 103-9539

<i>Ref.</i>	<i>Part Number</i>	<i>Qty.</i>	<i>Description</i>
1	92-5581	1	Ring-Retaining
2	109-2064	1	ASM, Bearing W/Orings
3	103-5895	4	O-Ring
4	103-9506	1	Spacer, Bearing
5	109-0764	1	ASM, Housing W/Studs

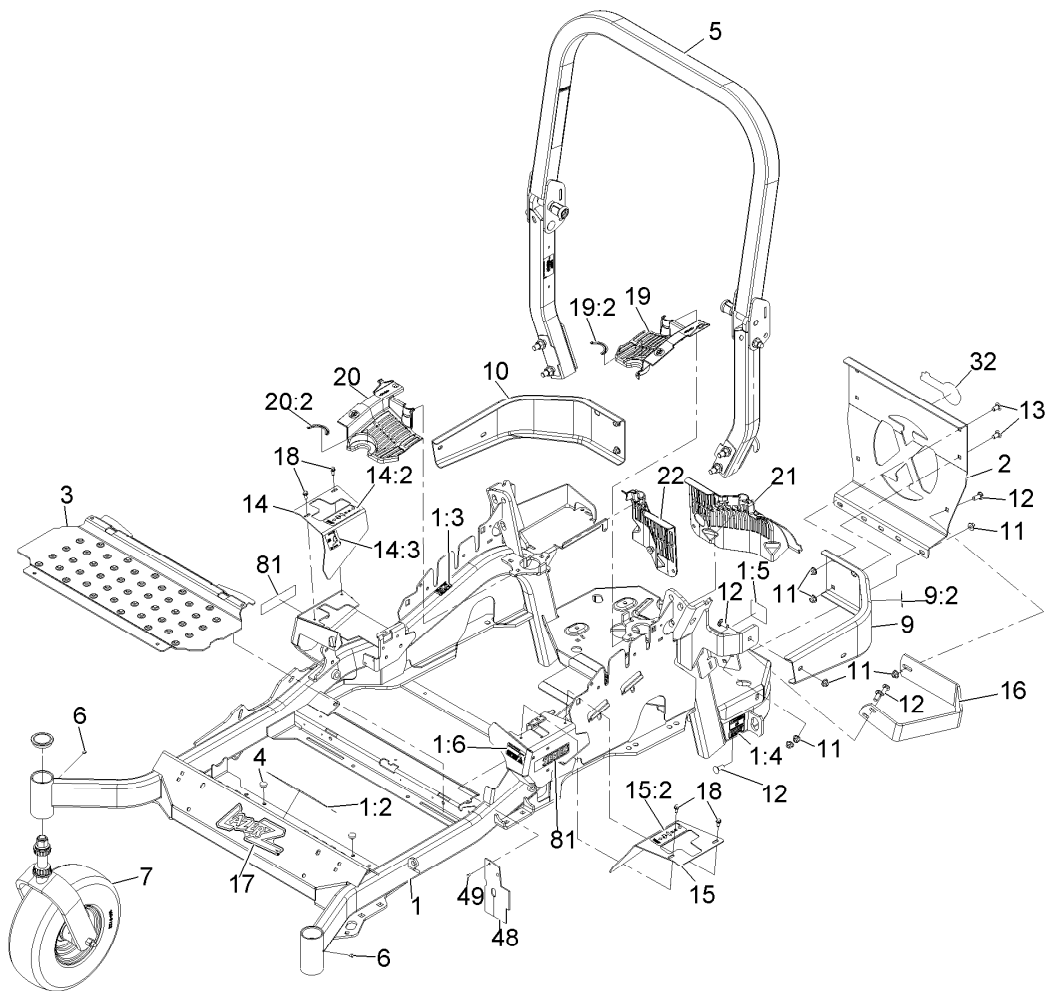

Main Frame Assembly

Ref.	Part Number	Qty.	Description	Ref.	Part Number	Qty.	Description
1	116-2126	1	Main Frame ASM	14:2	109-7232	1	Decal-Motion Control
1:2	116-3303	1	Decal-Slope	14:3	109-7929	1	Decal-Park Brake
1:3	103-2076	2	Decal-Caution	15	116-0580	1	LH Motion Control Cover ASM
1:4	116-0205	2	Decal-Belt Drive	15:2	109-7232	1	Decal-Motion Control
1:5	116-4858	1	Decal-Spark Arrester	16	116-0043-03	1	Guard-Muffler
1:6	116-1654	1	Decal Fuel Fill	17	103-3113	1	Decal,Lazer Model
2	109-8863-03	1	Plate,Rear Guard	18	32144-10	4	Screw-HWH 1/4-20 X .62
3	116-0024-01	1	Floorpan	19	116-0170	1	LH Hydro Guard ASM
4	1-513658	2	Bumper	19:2	116-0157	1	Decal-Hydro Oil
5	116-0230	1	ASM,ROPS Service Exmark	20	116-0171	1	RH Hydro Guard ASM
6	1-811010	2	Plug	20:2	116-0157	1	Decal-Hydro Oil
7		2	Caster Wheel ASM ●	21	109-9057	1	Guard-Hydro, Rear LH
9	116-0180	1	LH Bumper ASM	22	109-9058	1	Guard-Hydro, Rear RH
9:2	103-2076	1	Decal-Caution	32	103-2883	1	Decal,Exmark Logo
10	116-0057-03	1	Bumper-RH	48	116-2362	1	Deflector, Air Flow
11	104-8301	11	Nut-Nyloc 3/8-16 Flg	49	1-803035	2	Rivet 3/16 X 1/4
12	3231-22	7	Bolt-Carriage 3/8-16 X 1	81	116-3883	2	Decal-X-Series
13	3231-21	4	Bolt-Carriage 3/8-16 X 3/4				
14	116-0579	1	RH Motion Control Cover ASM				

● Not serviced separately

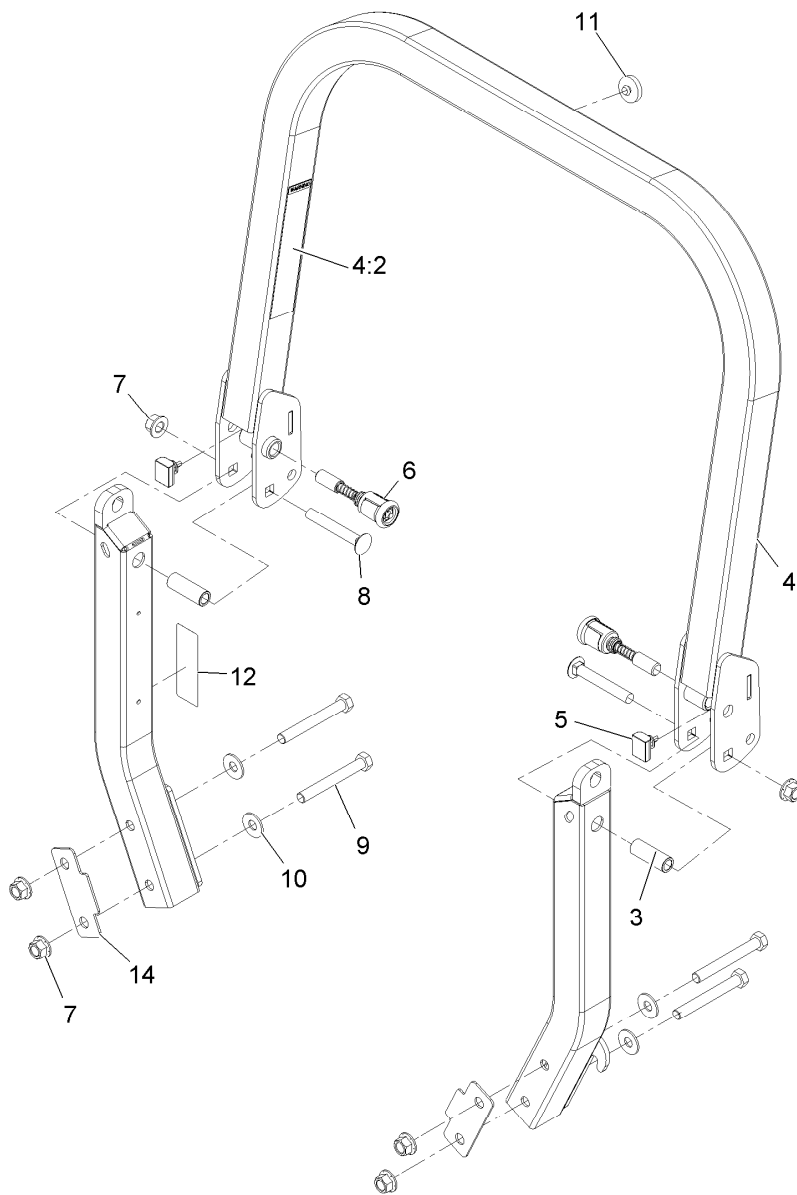

Roll-Over Protection System Assembly No. 116-0230

<i>Ref.</i>	<i>Part Number</i>	<i>Qty.</i>	<i>Description</i>
3	109-6653	2	Spacer
4	116-0019	1	Upper ROPS ASM
4:2	107-2102	1	Decal-Warning, Folding ROPS
5	109-5337	2	Bumper-ROPS
6	116-0104	2	Spring Pin ASM
7	99-5107	6	Nut-Lock 1/2-13
8	3233-10	2	Bolt-Carriage 1/2-13 X 3 1/2
9	325-17	4	Screw-HH 1/2-13 X 4
10	109-9505	4	Washer-Spring
11	109-9233	1	Bumper-Push-In, Rubber
12	116-0090	1	Decal-Caution
14	116-0960	2	Spacer

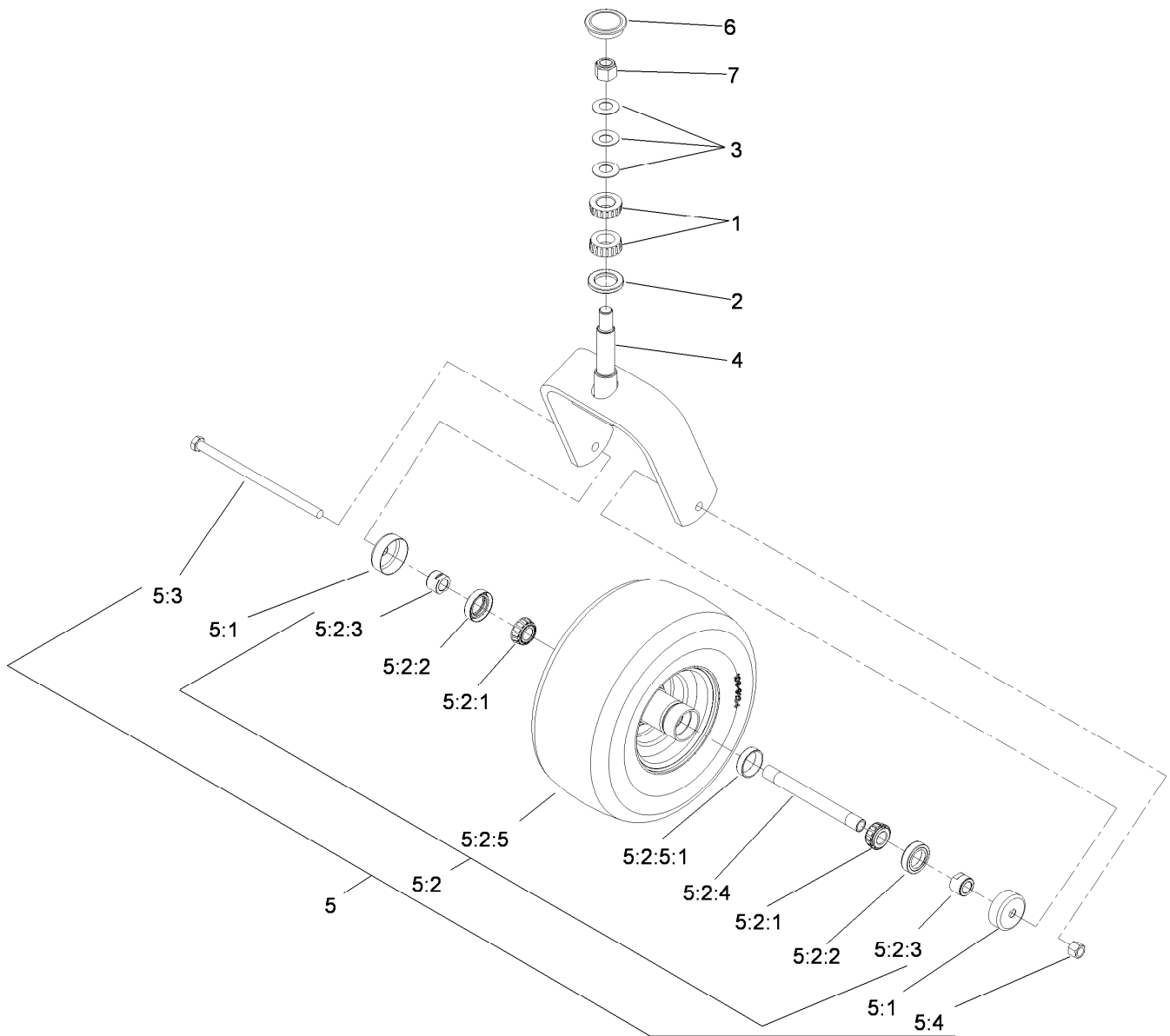

Caster Wheel and Fork Assembly

Ref.	Part Number	Qty.	Description	Ref.	Part Number	Qty.	Description
1	1-543509	2	Cone-Bearing Tapered Roller	5:2:2	103-0063	2	Seal-Double Lip
2	1-543511	1	Seal-Grease	5:2:3	103-3051	2	Spacer-Nut ■
3	1-633508	3	Washer-Spring Disc	5:2:4	103-5156	1	Axle-Caster
4	103-1474-01	1	Caster-Fork	5:2:5	109-9124	1	Wheel And Tire ASM
5	109-9127	1	Wheel And Tire ASM	5:2:5:1	1-633584	1	Bearing-Cup
5:1	103-2768	2	Guard-Seal	5:3	325-39	1	Screw-HH 1/2-13 X 9 1/2
5:2		1	Wheel And Tire ASM ●	5:4	3296-23	1	Nut-Nyloc 1/2-13
5:2:1	1-633585	2	Bearing-Cone Tapered Roller	6	103-4882	1	Cap-Grease
				7	3296-51	1	Nut-Nyloc 3/4-10

● Not serviced separately

■ Use Pro-Lock, Nut Type (P/N 1-840022, .5ml tube) on threads.

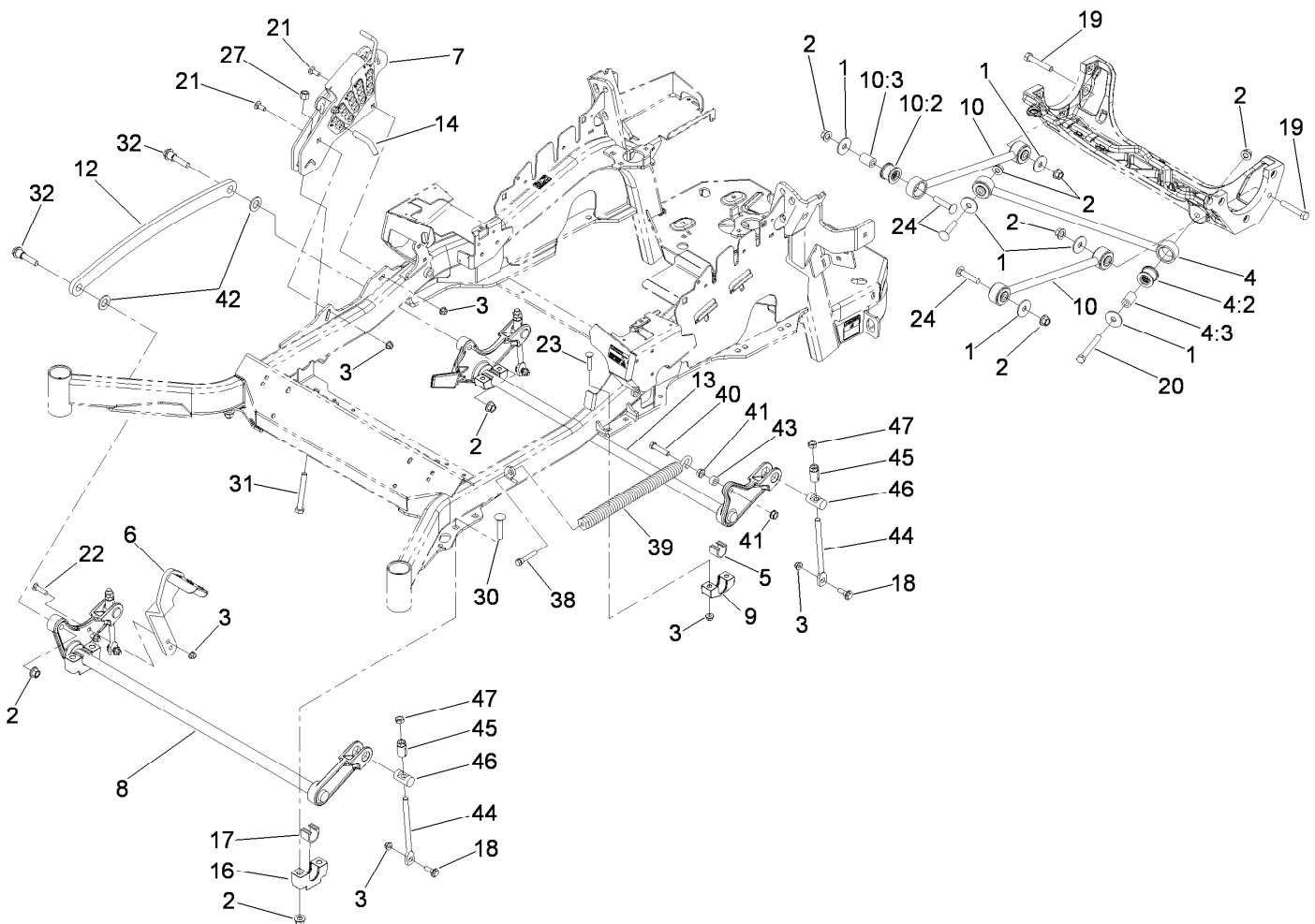

Deck Lift Assembly

Ref.	Part Number	Qty.	Description	Ref.	Part Number	Qty.	Description
1	86-1990	6	Washer	17	109-9410	2	Bearing-Shaft Front, Cross
2	99-5107	12	Nut-Lock	18	109-9840	4	Screw-Shoulder, HHF
3	104-8301	12	Nut-Flange, NI	19	325-12	2	Screw-HH
4	109-5013	1	Panhard Rod ASM	20	325-17	1	Screw-HH
4:2	109-5009	2	Bushing-Suspension, Rubber	21	3231-2	2	Screw-CARR
4:3	109-5010	2	Spacer	22	3231-4	2	Screw-CARR
5	109-7173	2	Bearing-Cross, Rear Shaft	23	3231-5	4	Screw-CARR
6	116-1919-01	1	Lever-Foot	24	3233-34	3	Screw-CARR
7	109-7438	1	Height-Of-Cut ASM	27	3296-23	1	Nut-Lock, NI
8	116-1771-03	1	Deck Lift-Front	30	116-1700	4	Screw-CARR,Spl
9	116-0818-03	2	Support-Bearing, Cross Shaft Rear	31	116-0559	1	Bolt-TAP
10	109-7952	2	Deck Strut ASM	32	116-2022	2	Screw-HHF, Shoulder
10:2	109-5009	2	Bushing-Suspension, Rubber	38	92-7674	1	Bolt-Shoulder
10:3	109-5010	2	Spacer	39	116-0000	1	Extension Spring ASM
12	116-0797-03	1	Link-Lift, Deck	40	109-9065	1	Screw-HH
13	116-2645-03	1	Lift-Deck, Rear	41	32128-37	2	Nut-HF
14	109-8757	1	Pin-HOC	42	3256-28	2	Washer-Flat
16	109-9409	2	Support-Cross Shaft, Bearing Front	43	116-2695	1	Spacer
				44	109-8007	4	Link-Adjuster, Deck Lift
				45	109-7840	4	Adjuster-Lift, Deck
				46	109-8353	4	Trunnion
				47	3218-5	4	Nut-Jam

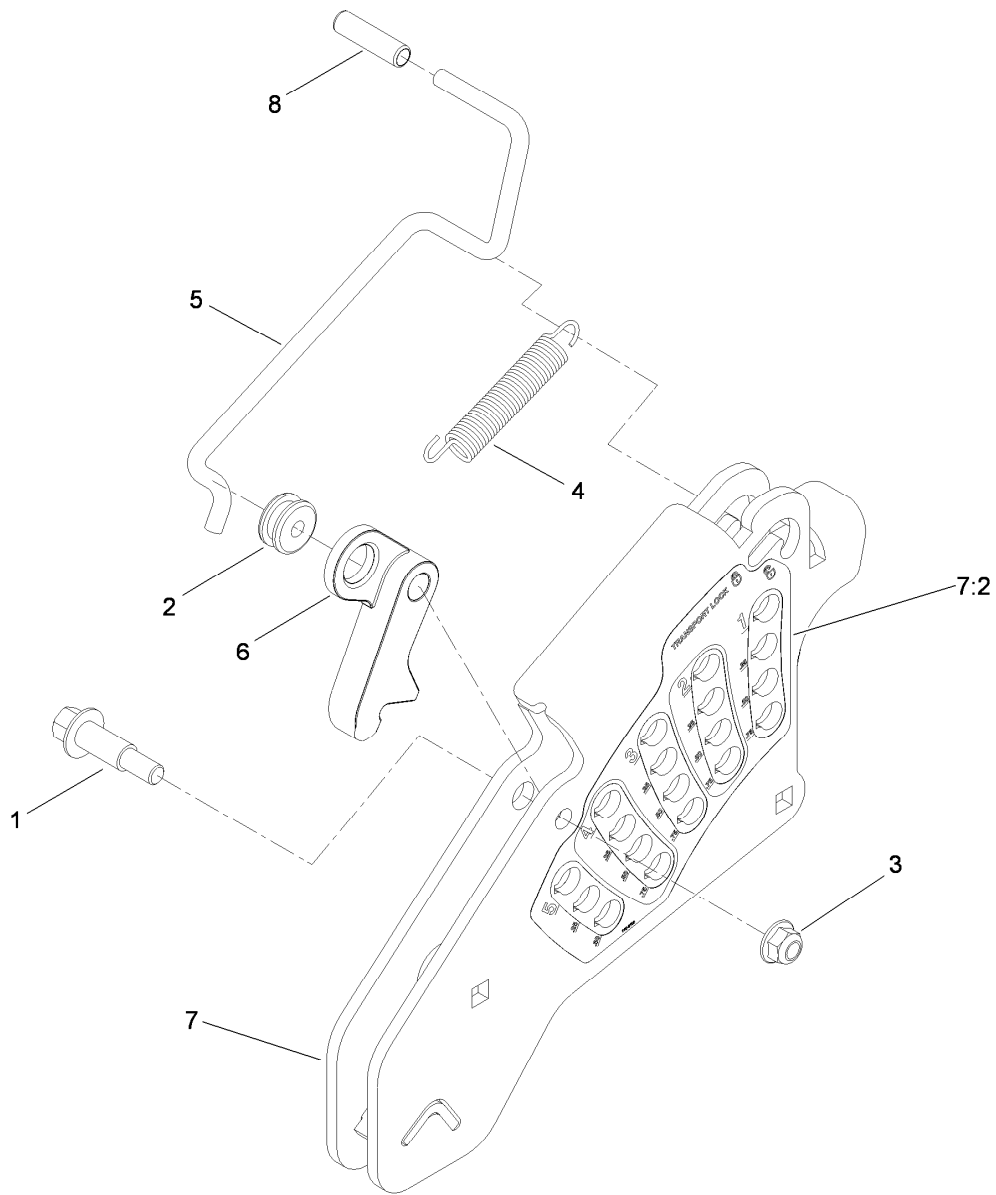

Height-of-Cut Assembly No. 109-7438

<i>Ref.</i>	<i>Part Number</i>	<i>Qty.</i>	<i>Description</i>
1	62-1330	1	Bolt-Shoulder
2	109-7130	1	Grommet
3	104-8301	1	Nut-Flange, NI
4	109-7124	1	Spring-Extension
5	109-7128	1	Rod-Lock, Transport
6	116-0118	1	Pawl-Transport, HOC
7	109-7335	1	HOC Plate ASM
7:2	116-0752	1	Decal-HOC
8	109-8250	1	Grip-Lever

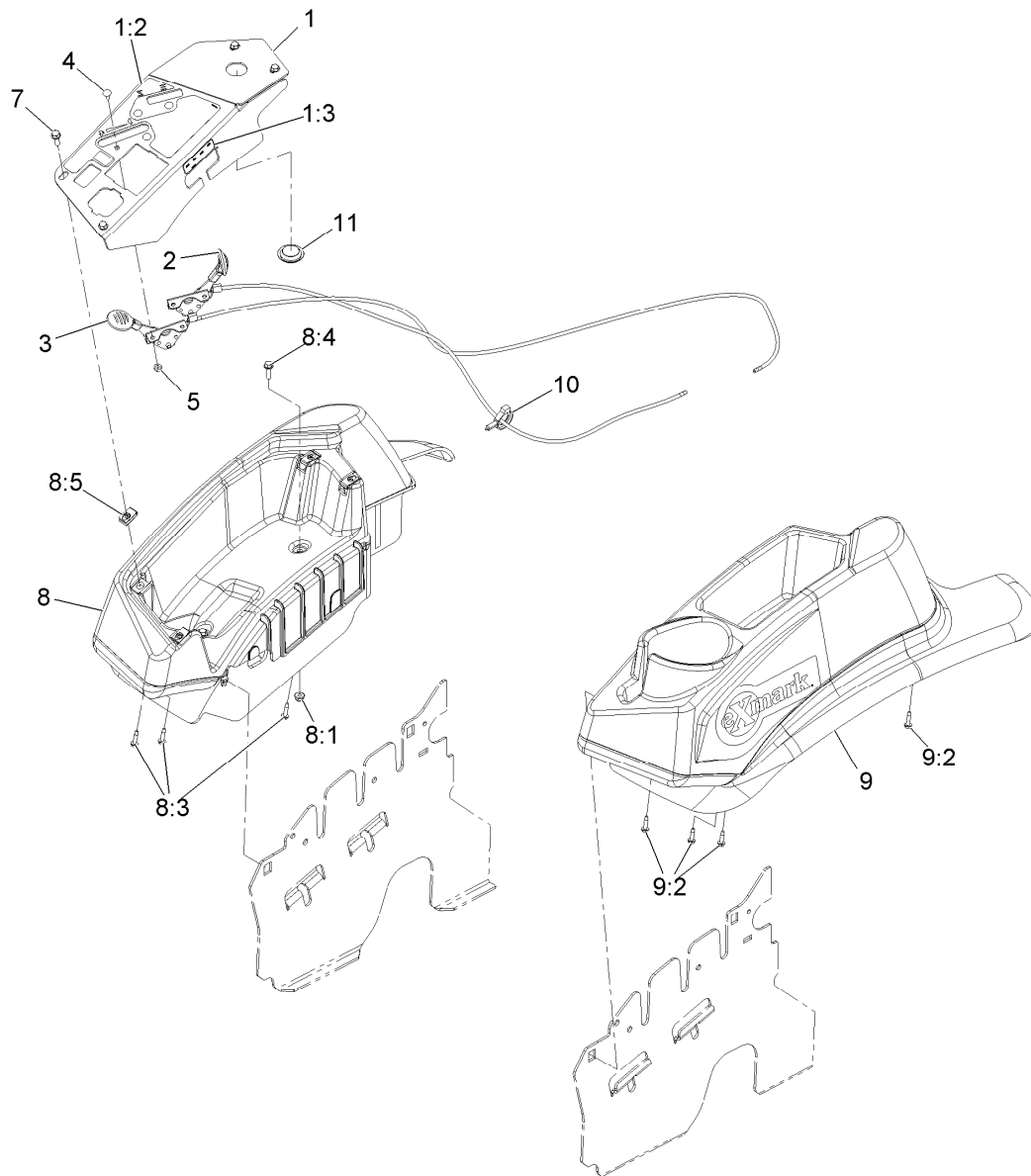

Controls Assembly

Ref.	Part Number	Qty.	Description
1	116-1845	1	ASM,Console Panel W/Decal
1:2	109-8483	1	Decal-Control Panel
1:3	109-7330	1	Decal-Fuse
2	109-8165	1	ASM, Choke Cable
3	116-0969	1	ASM,Throttle Cable
4	1-807513	4	Bolt-Carriage #10-24 X 1/2
5	3296-2	4	Nut-Nyloc #10-24
7	32105-15	4	Screw-Machine 1/4-20 X 3/4

Ref.	Part Number	Qty.	Description
8	109-9341	1	Console,RH Narrow ASM
8:1	104-7201	2	Nut-Nyloc 1/4-20 Fig
8:3	109-9345	3	Screw-HWH #10-14 X 3/4 Tf
8:4	32105-15	2	Screw-Machine 1/4-20 X 3/4
8:5	107069	4	Nut-Retainer-Panel 1/4-20
9	109-9342	1	Console.LH Narrow ASM
9:2	109-9345	4	Screw-HWH #10-14 X 3/4 Tf
10	105-1853	1	Clamp-Hose
11	116-1875	1	Plug,Plastic

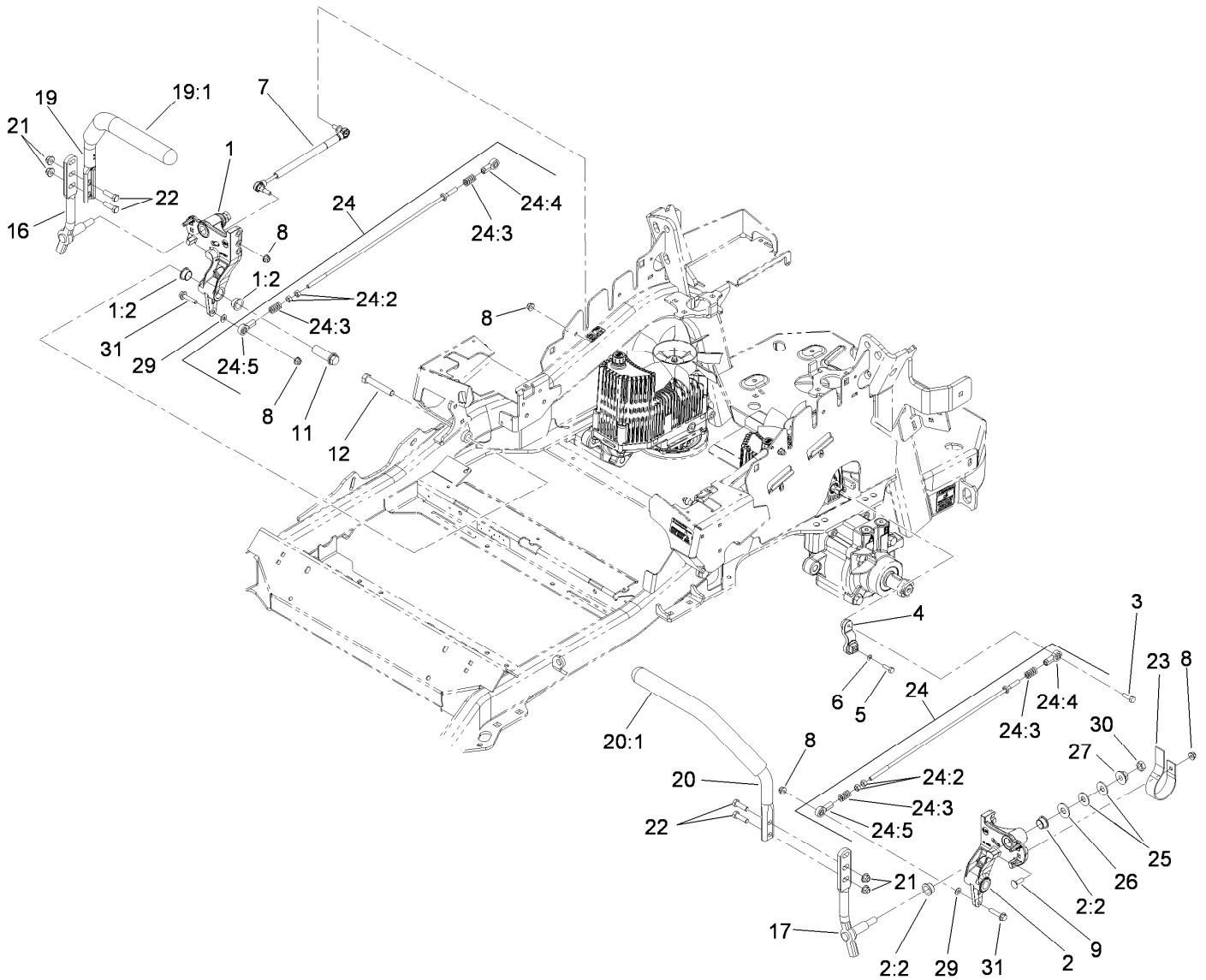

Motion Control Assembly

Ref.	Part Number	Qty.	Description	Ref.	Part Number	Qty.	Description
1	116-0880	1	RH Motion Control And Bushing ASM	19:1	109-5668	1	Grip,Control Lever
1:2	109-8054	4	Bushing-Flanged	20	109-6590	1	ASM,Steering Handle LH
2	116-0881	1	LH Motion Control And Bushing ASM	20:1	109-5668	1	Grip,Control Lever
2:2	109-8054	4	Bushing-Flanged	21	104-8301	4	Nut-Nyloc 3/8-16 Flg
3	116-0648	2	Screw-HH 5/16-18 X 1 W/Patch ●	22	323-7	4	Screw-HH 3/8-16 X 1 1/4
4	109-4581	2	Arm-Control, Pump	23	109-5575	2	Spring-Leaf
5	9080046	2	Screw-HH 1/4-20 X 7/8 ●	24	109-8106	2	Front Pump Linkage ASM
6	1-303435	2	Washer-Spring Disc 1/4	24:2	3219-2	2	Nut-Hex 5/16-24
7	116-0027	2	Damper-Control, Motion	24:3	1-323245	2	Spring-Compression
8	104-8300	8	Nut-Nyloc 5/16-18 Flg	24:4	1-633152	1	Balljoint
9	3230-2	2	Bolt-Carriage 5/16-18 X 1	24:5	1-543017	1	Balljoint
11	109-5891	2	Hub-Threaded	25	109-9505	4	Washer-Spring
12	325-12	2	Screw-HH 1/2-13 X 3	26	3256-6	2	Washer
16	116-0039	1	Lever-Control Motion, RH	27	32128-56	2	Nut-Hex 1/2-13 Flange
17	116-0040	1	Lever-Control Motion, LH	29	3256-23	2	Washer-5/16 Sae
19	109-6589	1	ASM,Steering Handle RH	30	3218-5	2	Nut-Jam 1/2-13
				31	115-1794	2	Screw-Hex Flange 5/16-18 X 1 1/2

● Use Pro-Lock, Nut Type (P/N 1-840022, .5ml tube) on threads.

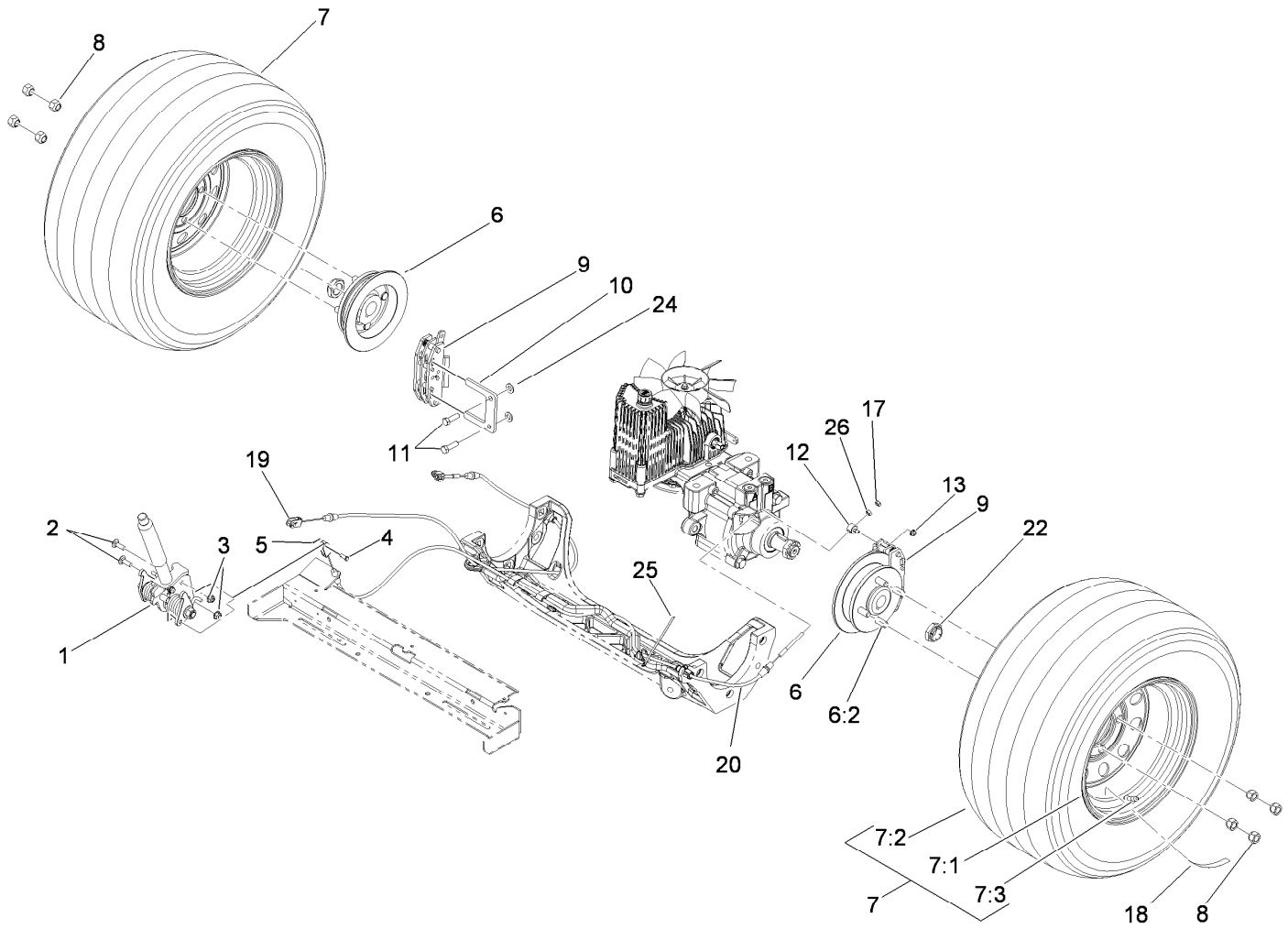

Rear Wheel and Park Brake Assembly

Ref.	Part Number	Qty.	Description	Ref.	Part Number	Qty.	Description
1	116-1878	1	Brake Handle ASM	10	109-0958	2	Plate-Mount, Brake
2	3230-2	2	Bolt-CARR	11	92-5727	4	Screw-Lock, Patch
3	104-8300	2	Nut-Flange, NI	12	112-8379	2	Swivel
4	60-1730	2	Pin-Clevis	13	104-7201	2	Nut-HF
5	3272-1	2	Pin-Cotter	17	3296-13	2	Nut-Lock, NI
6	116-1746	2	Wheel Hub ASM	18	116-2643	2	Decal-Wheel Nut Torque
6:2	116-1696	4	Stud-Wheel	19	115-3584	1	Cable
7	109-3248	2	Wheel And Tire ASM	20	115-3585	1	Cable
7:1	109-2871	1	Rim ASM	22	116-1399	2	Locknut, Wheel Motor
7:2	103-2744	1	Tire	24	3256-24	4	Washer-Flat
7:3	232-27	1	Stem-Valve	25	116-0940	1	Tie-Cable
8	242-50	8	Nut-Lug	26	3219-1	2	Nut-Hex
9	109-2889	2	Caliper-Brake				

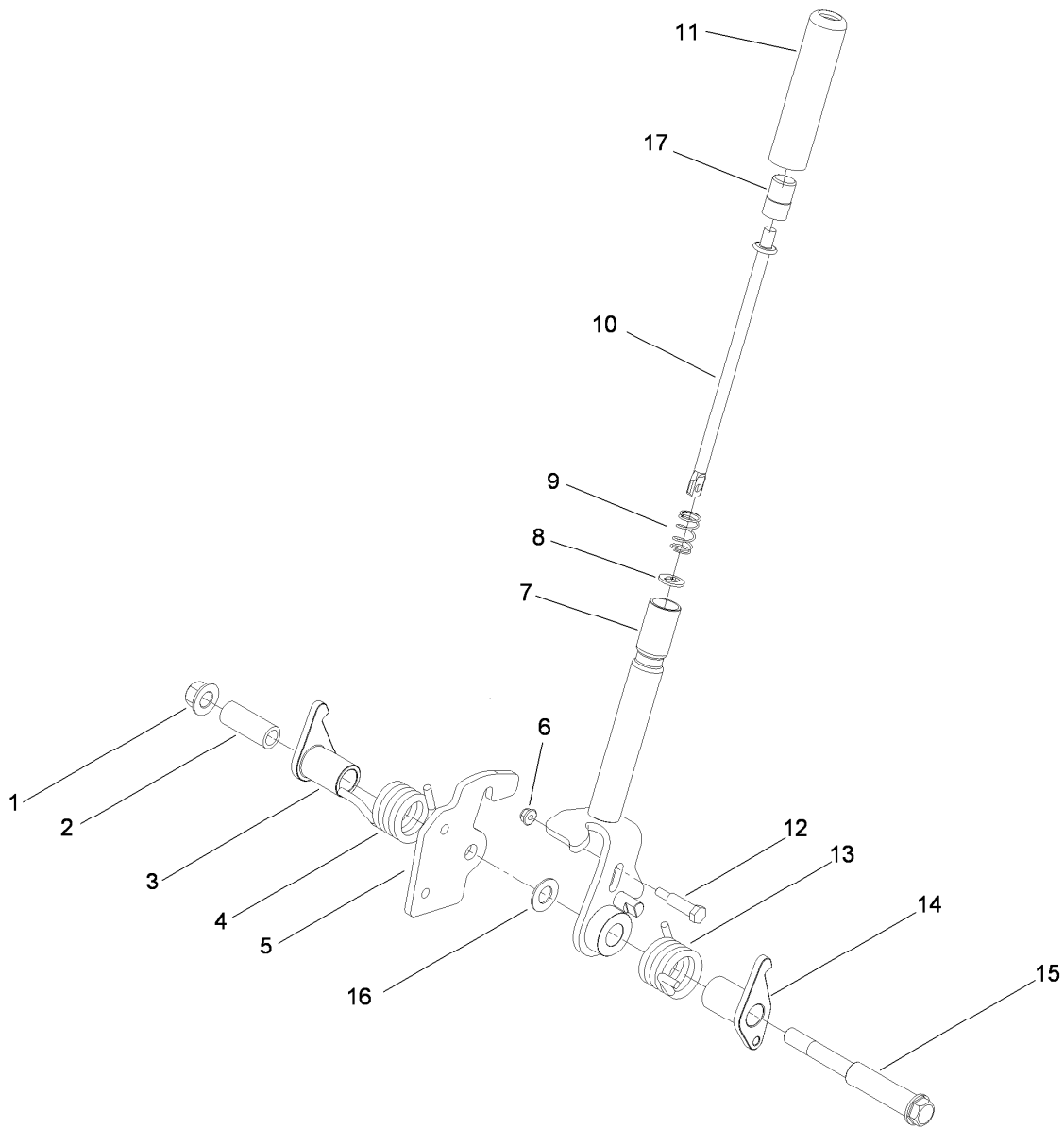

Brake Handle Assembly No. 116-1878

<i>Ref.</i>	<i>Part Number</i>	<i>Qty.</i>	<i>Description</i>	<i>Ref.</i>	<i>Part Number</i>	<i>Qty.</i>	<i>Description</i>
1	99-5107	1	Nut-Lock	10	115-3581	1	Rod-Release, Brake
2	117-0380	1	Spacer	11	115-3592	1	Grip
3	115-3580	1	Arm-Brake, LH	12	112-8387	1	Bolt-Shoulder
4	117-0376	1	Spring-Torsion, RH	13	117-0375	1	Spring-Torsion, LH
5	115-3574	1	Plate-Latch	14	115-3579	1	Arm-Brake, RH
6	104-7201	1	Nut-HF	15	117-0379	1	Bolt-Shoulder
7	116-1876-03	1	Brake Handle ASM	16	3256-26	1	Washer-Flat
8	114-1207	1	Washer-Special	17	115-2750	1	Knob
9	114-8187	1	Spring-Compression				

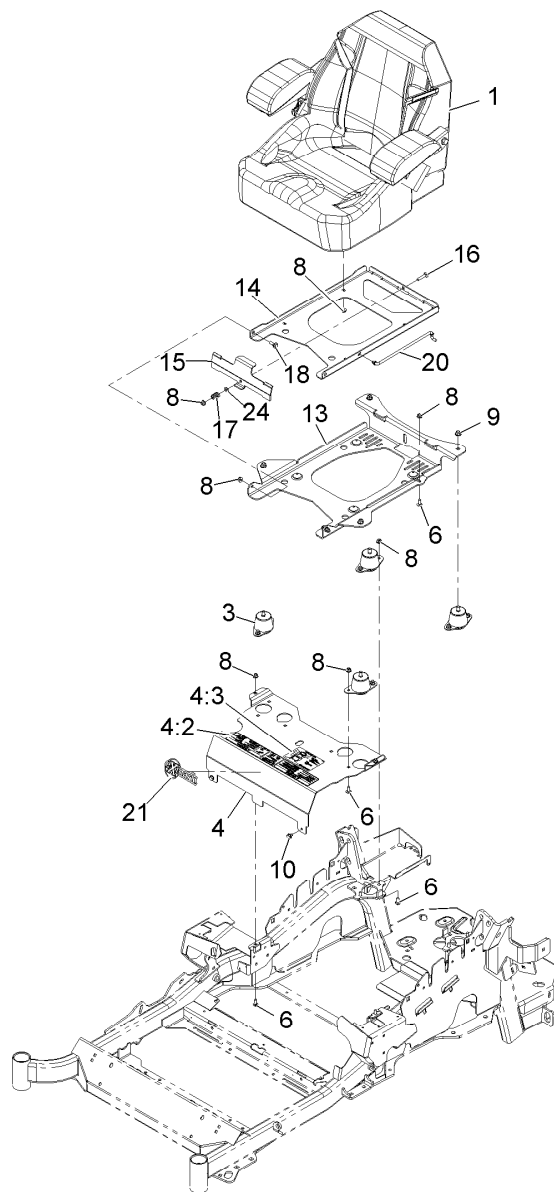

Seat Assembly

<i>Ref.</i>	<i>Part Number</i>	<i>Qty.</i>	<i>Description</i>	<i>Ref.</i>	<i>Part Number</i>	<i>Qty.</i>	<i>Description</i>
1	116-4474	1	Seat,Exmark Standard Service	13	116-0181-03	1	Plate-Support, Seat Tilt
3	109-9034	4	Isolator-Seat	14	116-0179-03	1	Plate-Frame, Seat Tilt
4	116-2323	1	Mount-Seat	15	109-9881-03	1	Plate-Latch, Seat
4:2	109-7069	1	Decal-Console	16	3230-4	1	Bolt-Carriage 5/16-18 X 1 1/2
4:3	116-0211	1	Decal-Service Aid	17	107-3017	1	Spring-Compression
6	3230-23	11	Bolt-Carriage 5/16-18 X 3/4 Short Neck	18	116-1297	2	Screw-Shoulder
8	104-8300	18	Nut-Nyloc 5/16-18 Flg	20	116-0070	1	Rod-Prop
9	104-8301	4	Nut-Nyloc 3/8-16 Flg	21	103-2883	1	Decal,Exmark Logo
10	9266934	2	Screw-HWH 5/16 X 1/2 Tf	24	3256-23	1	Washer-5/16 Sae

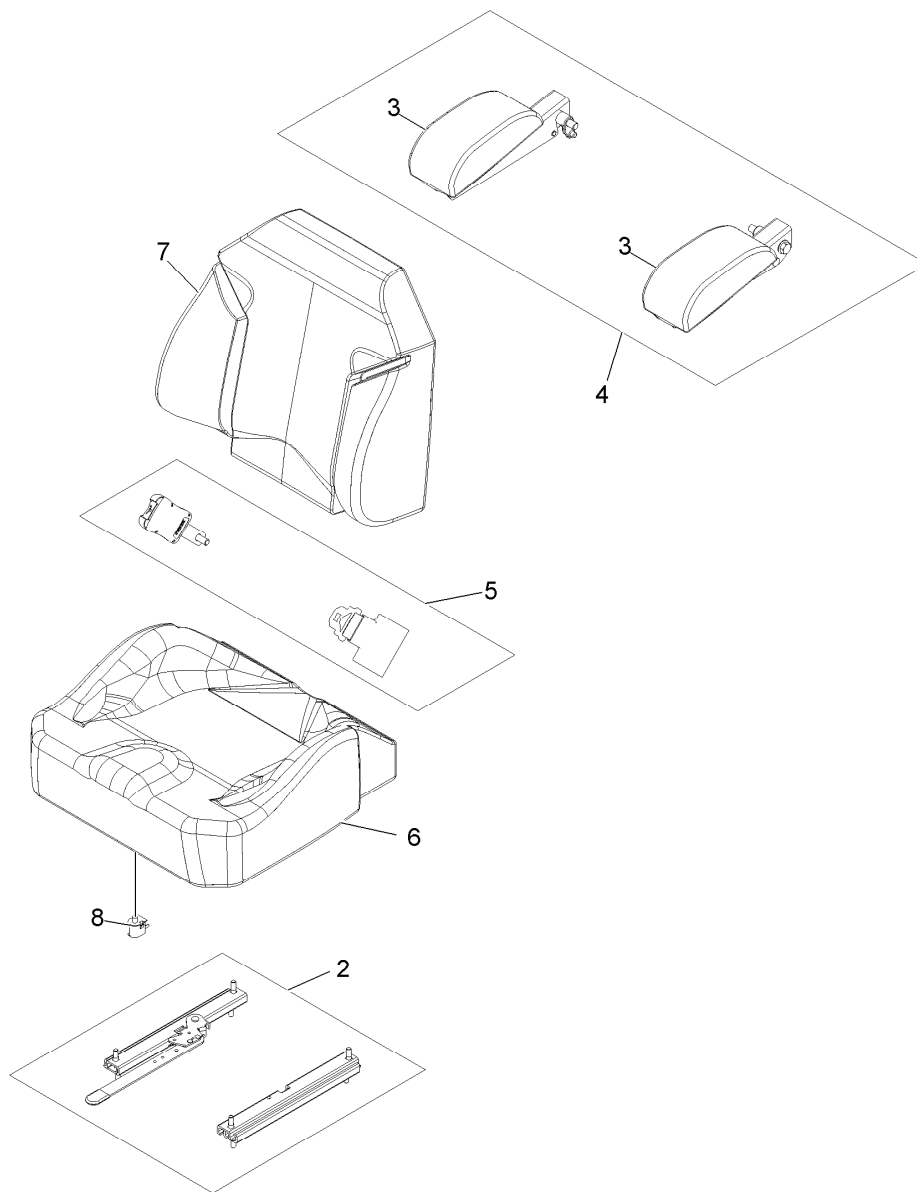

Seat W/Tracks Assembly No. 116-4474

<i>Ref.</i>	<i>Part Number</i>	<i>Qty.</i>	<i>Description</i>
2	109-9801	1	Seat Track Set
3	109-9802	1	Arm Rest Pad Set
4	109-9803	1	Arm Rest Set
5	109-9805	1	Seat Belt Kit
6	116-4925	1	Cover,Cushion
7	116-4926	1	Cover,Back
8	82-2190	1	Switch

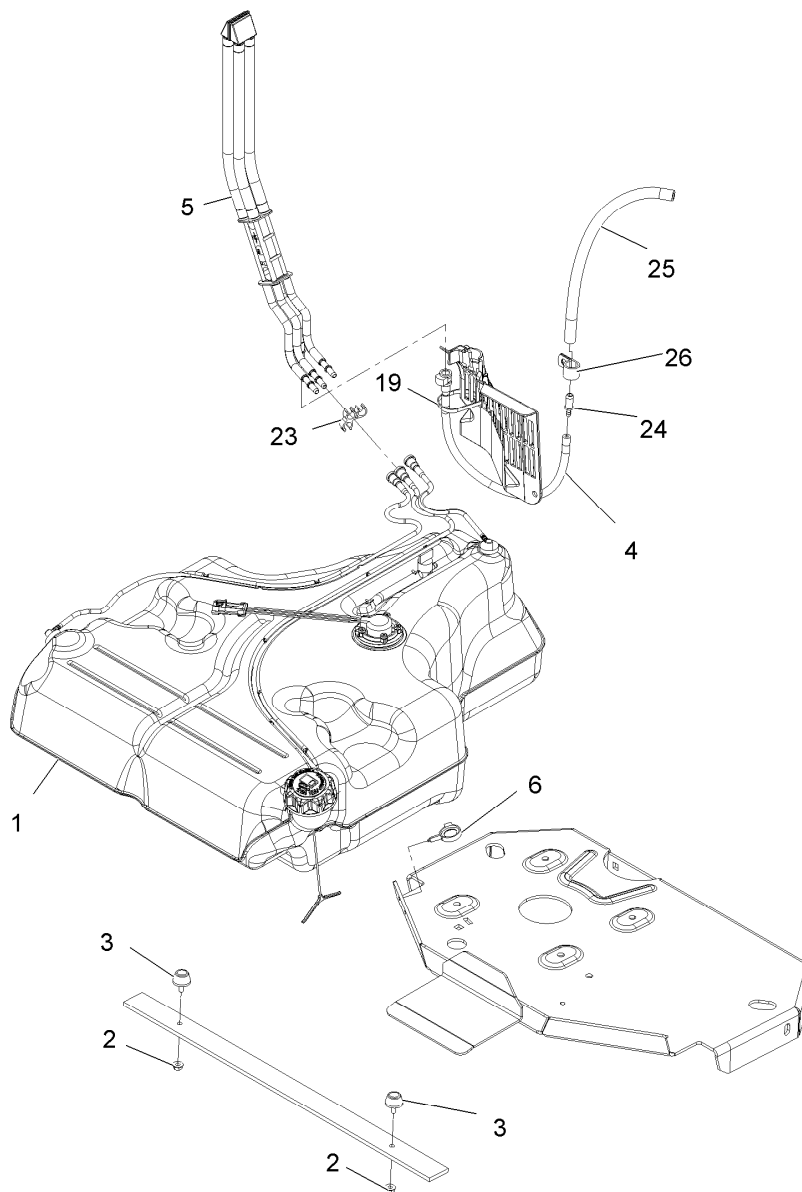

Fuel Tank Mounting Assembly

Ref.	Part Number	Qty.	Description
1	116-3979	1	Fuel Tank ASM
2	32128-33	2	Nut-Whizlock 1/4-20
3	109-2365	2	Rubber Bumper ASM (W/Stud)
4	116-3977	1	Hose ASM
5	109-9491	1	Fuel Manifold Vent ASM
6	105-1853	1	Clamp-Hose
19	1-303335	1	Tie-Cable 7 15/16 (Large)
23	116-3370	1	Clip-Spacer 1/2"
24	98-2952	1	Fitting-Straight
25	116-4344	1	Hose,Fuel
26	1-633396	1	Clip-Loom 5/8

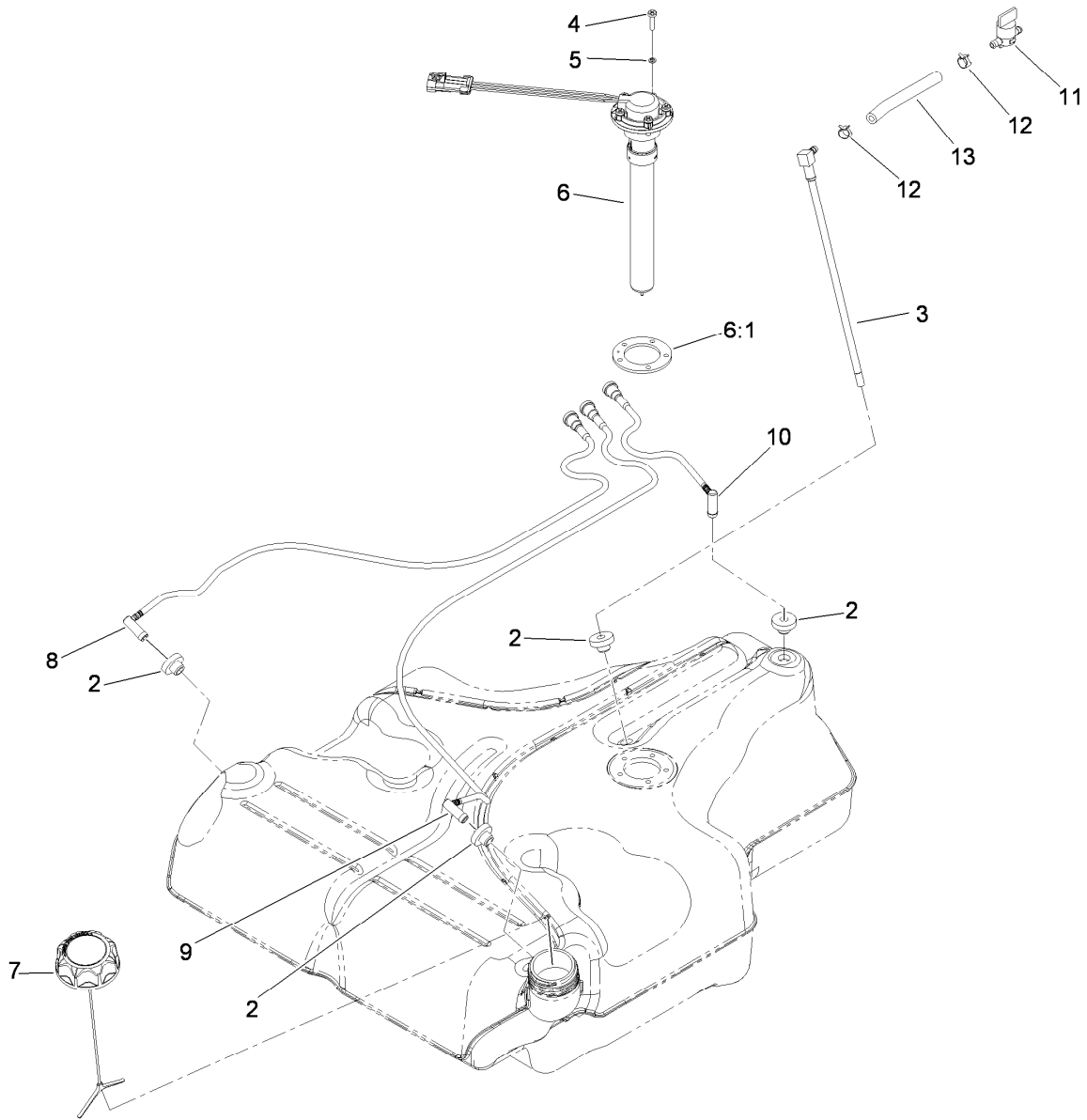

Fuel Tank Assembly No. 116-3979

Ref.	Part Number	Qty.	Description
2	46-6560	4	Bushing
3	116-2459	1	Fuel Line Kit (With Grommet)
4	9107944	5	Screw-Pan 10-24 X 3/4
5	3253-17	5	Washer-Lock 3/16
6	116-0003	1	Sender-Fuel Level
6:1	109-9620	1	Gasket-Sender, Fuel
7	116-1704	1	Cap-Fuel, Ratcheting
8	116-2460	1	RH Vent Line Kit (With Grommet)
9	116-2461	1	LH Vent Line Kit (With Grommet)
10	116-2462	1	Rear Vent Line Kit (With Grommet)
11	1-603770	1	Valve-Fuel
12	2412-98	2	Clamp-Hose
13	109-0650	1	Hose-Fuel

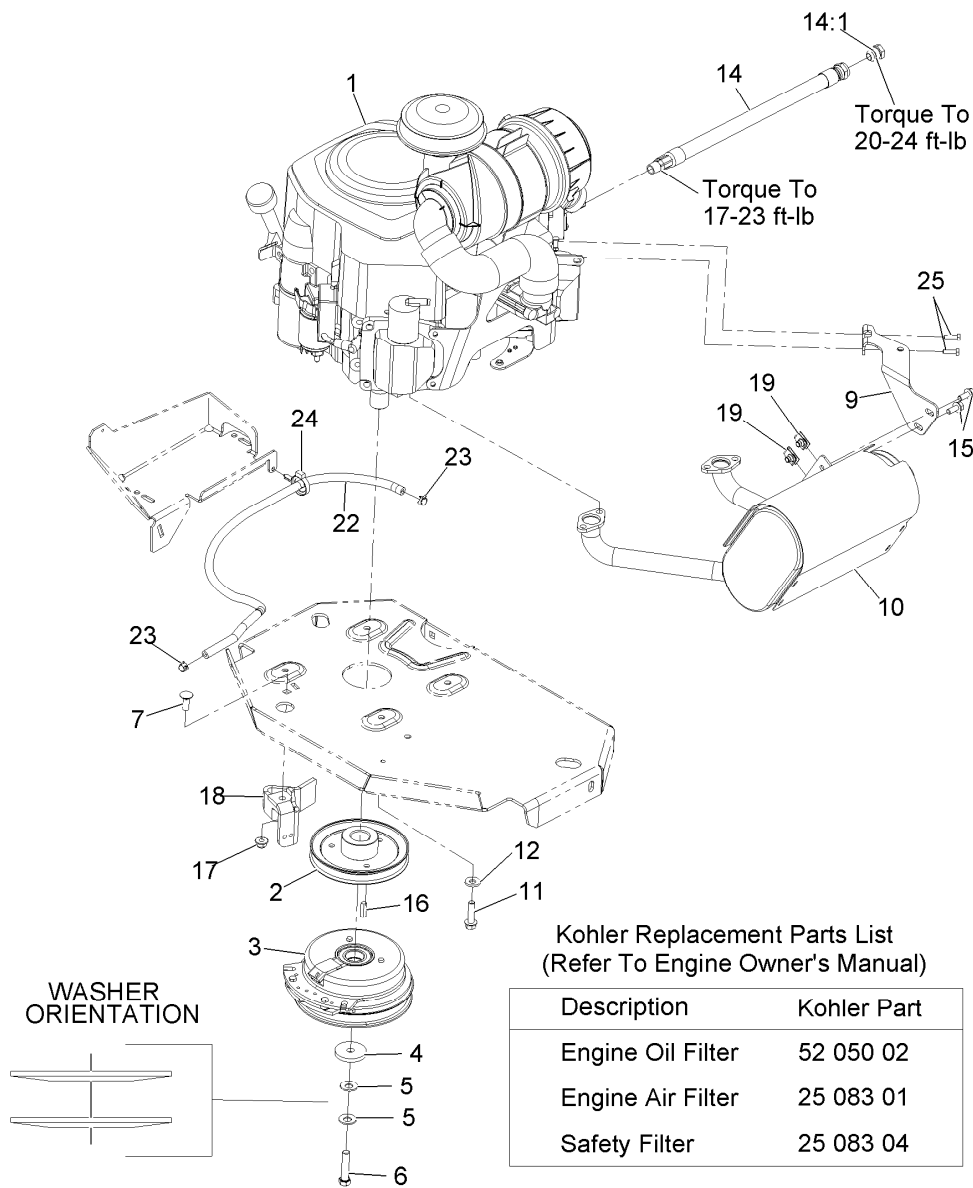

Engine Assembly

Ref.	Part Number	Qty.	Description	Ref.	Part Number	Qty.	Description
1		1	Engine, Koh 27Hp HD ●■	14	116-0013	1	Oil Drain Hose ASM
2	109-9905	1	Sheave	14:1	109-1012	1	Plug
3	116-1620	1	Clutch Kit	15	3234-5	3	Screw-HH Flg 5/16-18 X 3/4
4	109-6919	1	Washer-Clutch	16	1-807259	1	Key-Machine 1/4 X 1/4 X 1
5	1-603610	2	Washer-Spring Disc 7/16	17	104-8301	1	Nut-Nyloc 3/8-16 Flg
6	109-9762	1	Screw-HH 7/16-20 X 2 W/Loctite	18	116-2612-01	1	Clutch-Anchor
7	3231-22	1	Bolt-Carriage 3/8-16 X 1	19	94-2413	3	U-Nut
9	116-4297	1	Kit, Koh Muffler Brkt	22	109-0286	1	Hose-Fuel Line 35"
10	116-1713	1	Muffler	23	2412-98	2	Clamp-Hose
11	32144-102	4	Screw-HWH 3/8-16 X 1 1/2 Taptite	24	104-2490	1	Clamp-Hose
12	98-5975	4	Washer-Spring Disc 3/8	25	116-4295	2	Screw-HH M6-1 X 20Mm W/Patch

● Not serviced separately

■ Obtain parts from www.kohlerplus.com

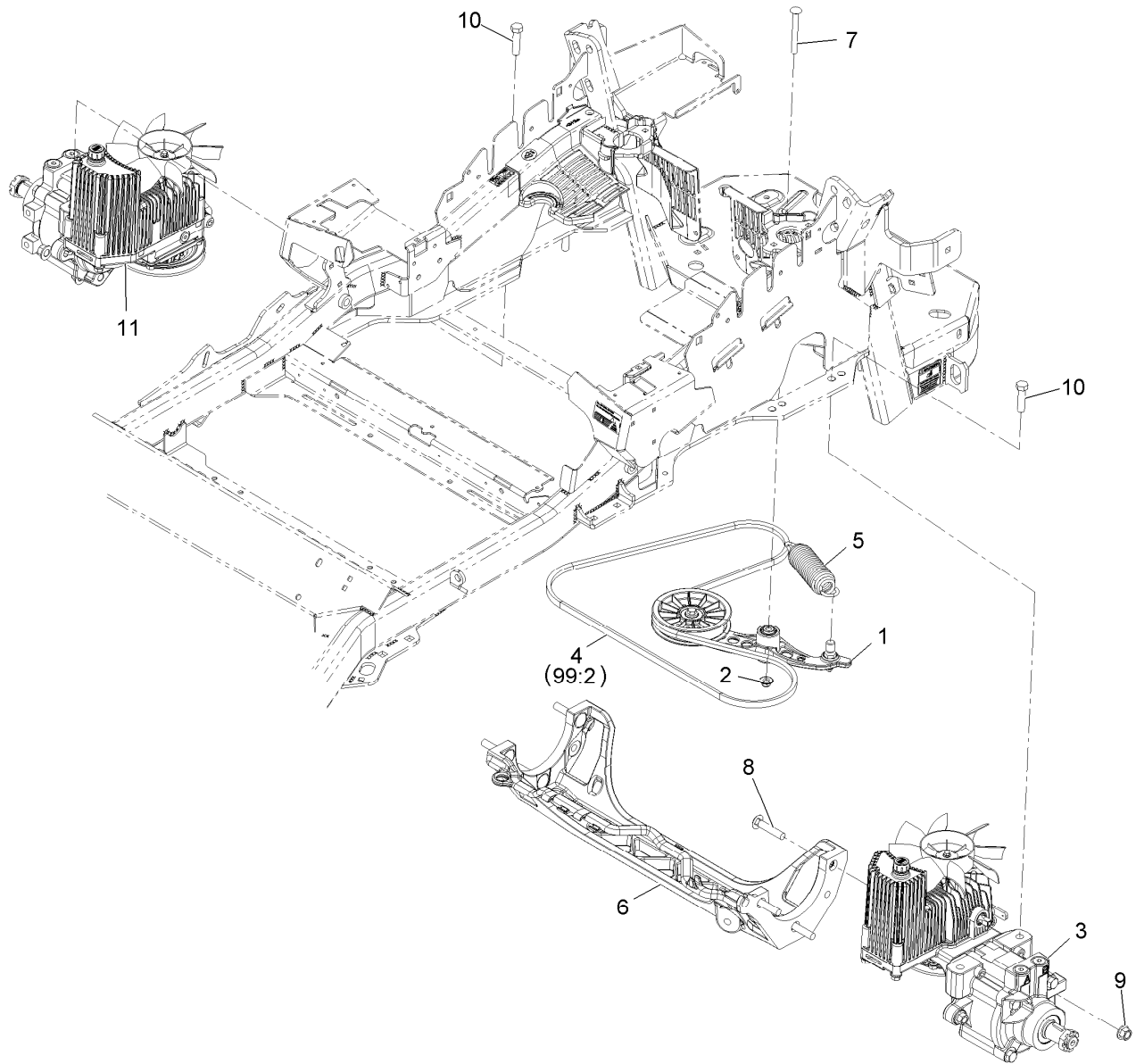

Hydraulic Assembly

Ref.	Part Number	Qty.	Description	Ref.	Part Number	Qty.	Description
1	116-1255	1	Pump Idler ASM	10	325-8	4	Screw-HH 1/2-13 X 1 1/4
2	109-6658	1	Nut-Nyloc 3/8-16 Flg	11	116-1327	1	RH Hydro ASM (16Cc W/Shock)
3	116-1326	1	LH Hydro ASM (16Cc W/Shock)	99	109-9828	1	Bottle-Oil, 32Oz Hydraulic ●
4	109-3388	1	Belt	99	116-0164	1	Filter-Hydro ●
5	116-0133	1	Extension-Spring	99	116-1218	1	Bottle,Oil 1 Gallon Hydraulic ●
6	109-9375	1	Cradle-Hydro	99	116-3270	1	Kit, Hydro Service ●
7	116-1502	1	Bolt-Carriage Shoulder 3/8-16 X 3 1/2	99:1	109-9828	4	Bottle-Oil, 32Oz Hydraulic ●
8	3233-34	6	Bolt-Carriage 1/2-13 X 2 1/2	99:2	109-3388	1	Belt
9	99-5107	6	Nut-Lock 1/2-13	99:3	116-0164	2	Filter-Hydro ●

● Not illustrated

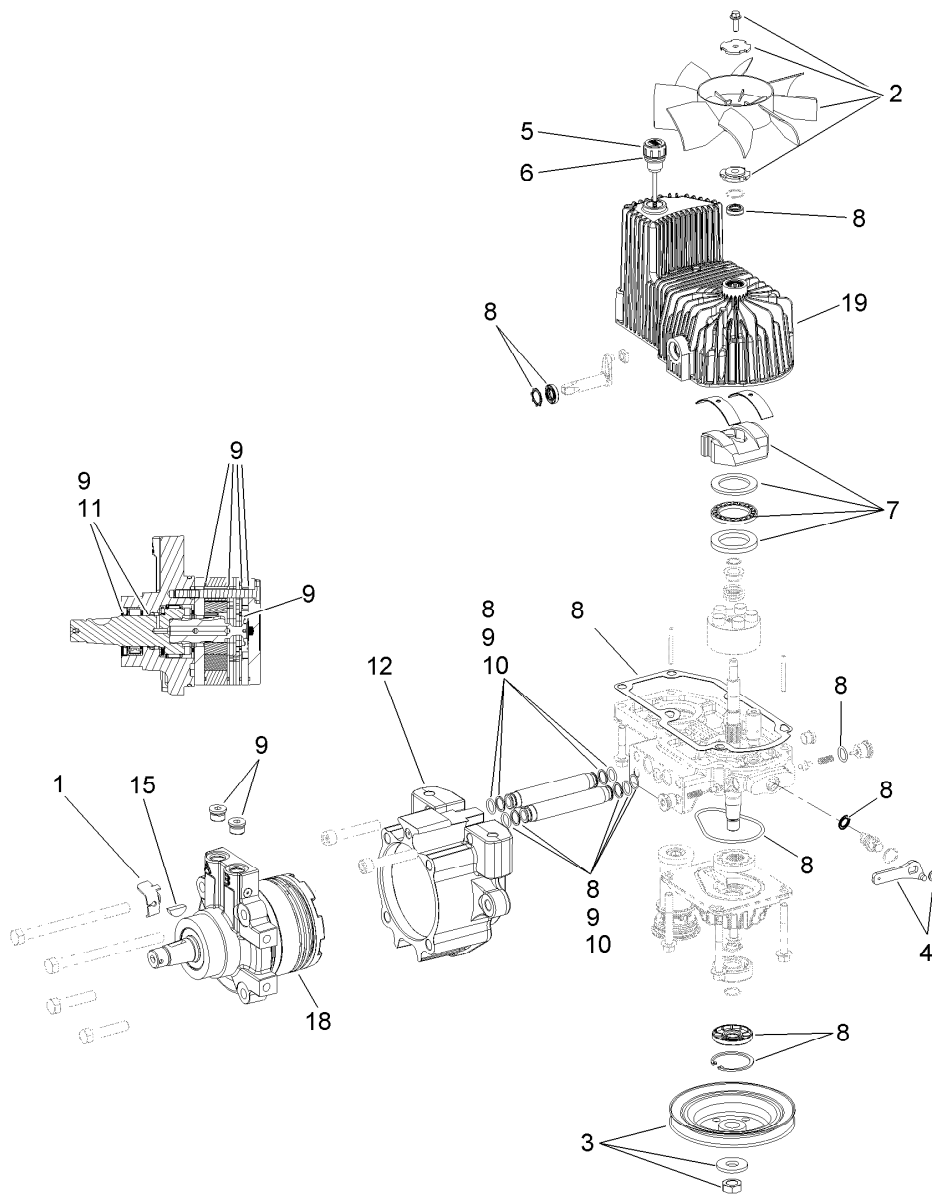

LH Hydro Assembly No. 116-1326

<i>Ref.</i>	<i>Part Number</i>	<i>Qty.</i>	<i>Description</i>	<i>Ref.</i>	<i>Part Number</i>	<i>Qty.</i>	<i>Description</i>
1	116-1758	1	Bracket-Anchor, Cable	9	116-1369	1	Motor Seal Kit
2	116-0233	1	Fan Kit	10	116-1370	1	Tube Seal Kit
3	116-0234	1	Pulley Kit	11	116-1371	1	Output Shaft Seal Kit
4	116-0235	1	Handle-Bypass Valve, Hydro	12	116-2992	1	Cup-Nose Hydro Dry
5	116-0236	1	Dipstick-Hydro W/Gasket	15	3257-42	1	Key-Woodruff 5/16 X 1
6	116-0237	1	Gasket-Dipstick, Hydro	18	116-2990	1	Motor-Wheel LH Dry 280Cc
7	116-1367	1	Swash Block Kit	19	116-3287	1	Housing-LH
8	116-1368	1	Pump Seal Kit	99	116-1373	1	Flow Test Kit ●

● Not illustrated

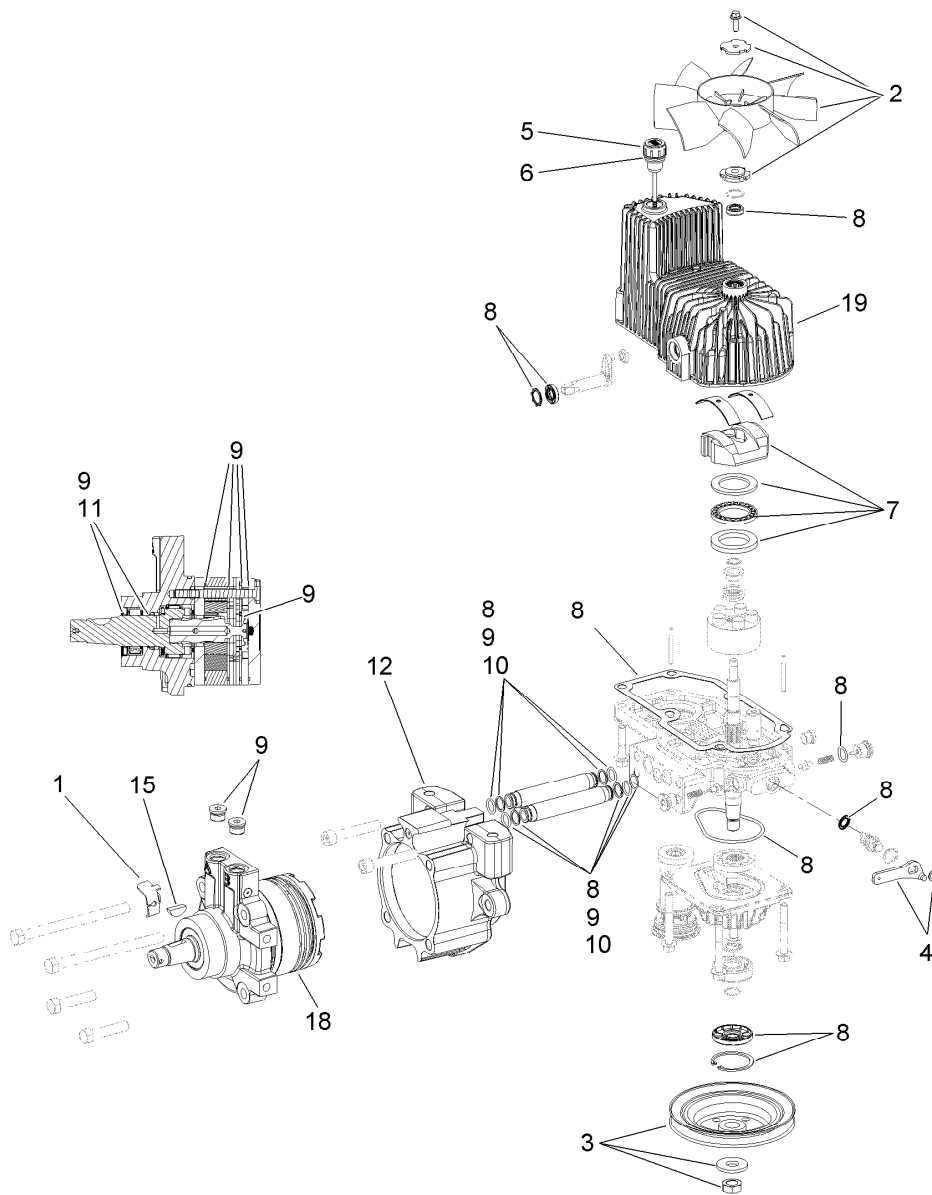

RH Hydro Assembly No. 116-1327

<i>Ref.</i>	<i>Part Number</i>	<i>Qty.</i>	<i>Description</i>	<i>Ref.</i>	<i>Part Number</i>	<i>Qty.</i>	<i>Description</i>
1	116-1758	1	Bracket-Anchor, Cable	9	116-1369	1	Motor Seal Kit
2	116-0233	1	Fan Kit	10	116-1370	1	Tube Seal Kit
3	116-0234	1	Pulley Kit	11	116-1371	1	Output Shaft Seal Kit
4	116-0235	1	Handle-Bypass Valve, Hydro	12	116-2992	1	Cup-Nose Hydro Dry
5	116-0236	1	Dipstick-Hydro W/Gasket	15	3257-42	1	Key-Woodruff 5/16 X 1
6	116-0237	1	Gasket-Dipstick, Hydro	18	116-2991	1	Motor-Wheel RH Dry 280Cc
7	116-1367	1	Swash Block Kit	19	116-3288	1	Housing-RH
8	116-1368	1	Pump Seal Kit	99	116-1373	1	Flow Test Kit ●

● Not illustrated

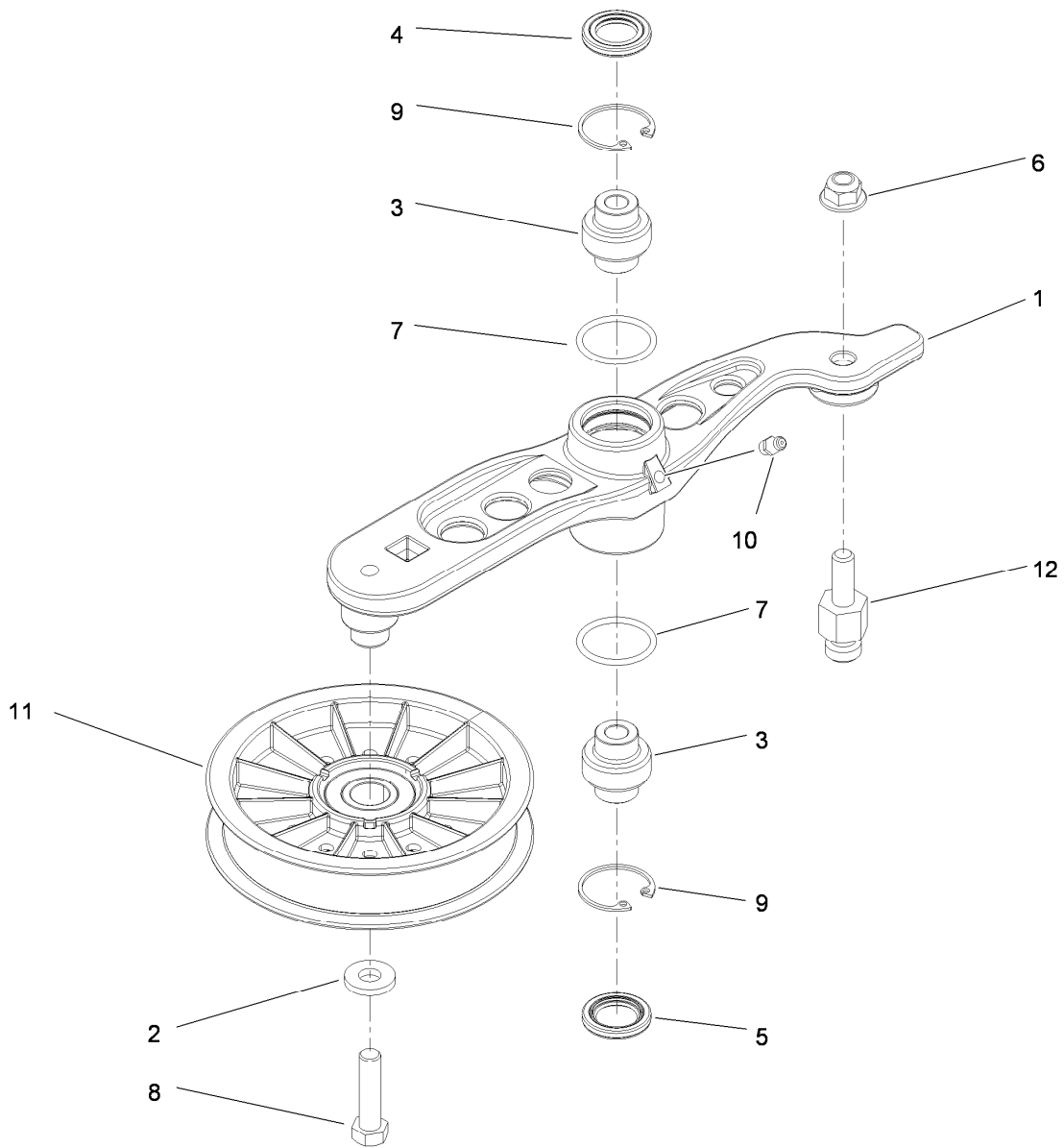

Pump Idler Assembly No. 116-1255

Ref.	Part Number	Qty.	Description
1		1	Arm-Pump, Idler ●
2	43-0940	1	Spacer-Hub, Blower
3	103-3504	2	Bearing-Spherical
4	103-3505	1	Seal-Double Lip
5	103-3506	1	Seal-Single Lip
6	109-6658	1	Nut-Nyloc 3/8-16 Flg
7	106-7159	2	O-Ring
8	323-8	1	Screw-HH 3/8-16 X 1 1/2
9	32120-10	2	Ring-Retaining
10	302-19	1	Zerk-1/4-28 Str
11	109-8076	1	Pulley-Idler
12	116-3467	1	Pin, Spring Anchor

● Not serviced separately

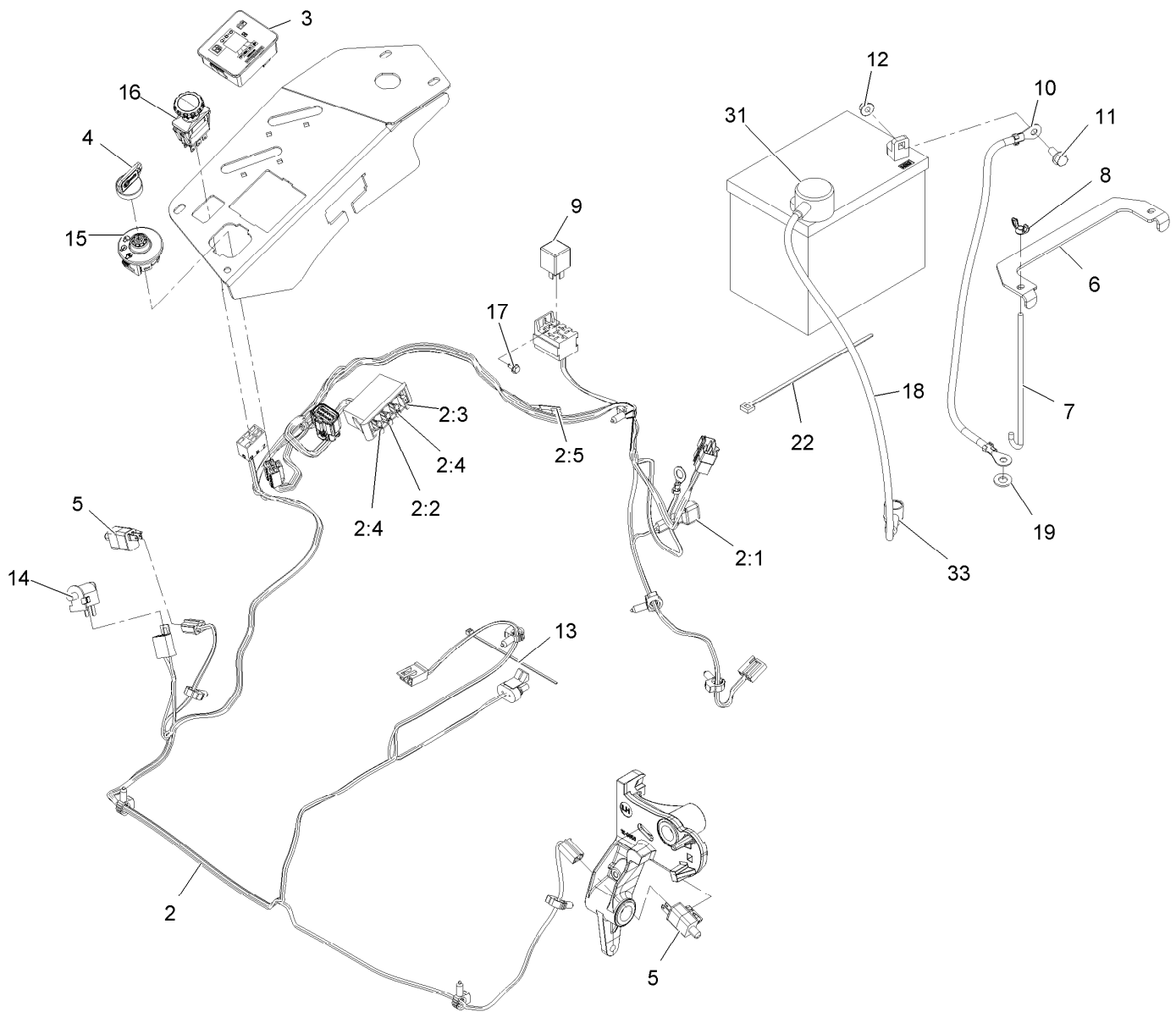

Electrical Assembly

<i>Ref.</i>	<i>Part Number</i>	<i>Qty.</i>	<i>Description</i>	<i>Ref.</i>	<i>Part Number</i>	<i>Qty.</i>	<i>Description</i>
2	115-2796	1	Harness-Wire, Main ●	10	114-1218	1	Cable-Battery, Negative
2:1	103-3895	1	Diode-Tvs	11	3234-5	2	Screw-HH Flg 5/16-18 X 3/4
2:2	218-578	1	Fuse-Blade, 10 Amp	12	104-8300	2	Nut-Nyloc 5/16-18 Flg
2:3	109355	1	Fuse-Blade, 15 Amp	13	1-303287	3	Tie-Cable 5 1/2 (Small)
2:4	109102	2	Fuse-Blade, 25 Amp	14	82-2190	1	Switch
2:5	116-0053	1	Cap-Plug	15	117-2221	1	Switch-Ignition
3	117-3882	1	Fuel/Hour Meter ASM	16	116-0124	1	Switch-PTO, 10A
4	1-603511	1	Key-Ignition	17	104-2065	1	Screw-HWH #10-24 X 3/8
4	103-2106	1	Key-Exmark Logo	18	115-3864	1	Cable-Battery, Positive
5	110-6765	2	Switch-Single Pole No	19	3256-24	1	Washer-3/8 Sae
6	116-0042-03	1	Strap-Tie Down, Battery	22	1-303335	1	Tie-Cable 7 15/16 (Large)
7	1-633651	2	Bolt-Holddown	31	109-2407	1	Insulator-Battery
8	1-543792	2	Wingnut-Nyloc 1/4-20	33	1-543393	1	Insulator-Solenoid
9	1-643275	1	Relay-12Vdc 40 Amp				

● Use dielectric grease on all wiring harness connectors.

Notes:

EXMARK® MAINTENANCE

MAXIMIZE THE PERFORMANCE OF YOUR EXMARK.

4-CYCLE PREMIUM ENGINE OIL

Part No. 116-3373

Both SAE 30 and SAE 10W-30 in one bottle.

Contains increased levels of zinc and phosphorus for better lubricity.

No Viscosity Index Improvers that tend to shear down in high heat.

Synthetic formulation.

Gas & Diesel compatible.

Anti-corrosion additives.

API 'SL' and JASO rated with wet clutch compatibility for other machines.

PREMIUM HYDRO OIL

Part No. 109-9828

Commercial quality for tough, high-heat conditions.

Designed specifically for zero-turn mower hydraulic systems.

Superior shear resistance under heavy loads.



Available from your local Exmark dealer. Find your closest dealer at exmark.com

SEE EXMARK'S COMPLETE LINE OF ACCESSORIES AND OPTIONS

MID-MOUNT RIDING ACCESSORIES AND OPTIONS

CUSTOM RIDE SEAT SUSPENSION SYSTEM	OPERATOR CONTROLLED DISCHARGE
FULL SUSPENSION SEAT	ROLL OVER PROTECTION SYSTEM (ROPS)
DECK LIFT ASSIST KIT	SUN SHADE
HITCH KIT	TRASH CONTAINER
LIGHT KIT	TURF STRIPER
12V POWER PORT	ULTRA VAC COLLECTION SYSTEM
MICRO-MULCH SYSTEM	ULTRA VAC QUICK DISPOSAL SYSTEM

OUT-FRONT RIDING ACCESSORIES AND OPTIONS

CUSTOM RIDE SEAT SUSPENSION SYSTEM	SNOW BLADE
DUAL-TAIL WHEEL	SNOWBLOWER
FLOOR PAN EXTENDER	SUN SHADE
HITCH KIT	TRASH CONTAINER
LIGHT KIT	ULTRA VAC COLLECTION SYSTEM
MICRO-MULCH SYSTEM	ULTRA VAC QUICK DISPOSAL SYSTEM
ROLL OVER PROTECTION SYSTEM (ROPS)	WEATHER CAB

WALK-BEHIND ACCESSORIES AND OPTIONS

GRASS CATCHER	TURF STRIPER
MICRO-MULCH SYSTEM	STANDON

Place Model No. and Serial No.
Label Here (Included in the Literature
Pack) or Fill in Below

Model No. _____

Serial No. _____

Date Purchased _____

Engine Model No. and Spec. No. _____

Engine Serial No. (E/No) _____

© 2010 Exmark Mfg. Co., Inc.
Industrial Park Box 808
Beatrice, NE 68310
All Rights Reserved

Part No. 4500-786 Rev. A
(402) 223-6300
Fax (402) 223-5489
Printed in the USA.

